



Durham E-Theses

Halogenation with chlorine trifluoride

Tanner, M. C.

How to cite:

Tanner, M. C. (1955) *Halogenation with chlorine trifluoride*, Durham theses, Durham University. Available at Durham E-Theses Online: <http://etheses.dur.ac.uk/10265/>

Use policy

The full-text may be used and/or reproduced, and given to third parties in any format or medium, without prior permission or charge, for personal research or study, educational, or not-for-profit purposes provided that:

- a full bibliographic reference is made to the original source
- a [link](#) is made to the metadata record in Durham E-Theses
- the full-text is not changed in any way

The full-text must not be sold in any format or medium without the formal permission of the copyright holders.

Please consult the [full Durham E-Theses policy](#) for further details.

A THESIS

ENTITLED

HALOGENATION WITH CHLORINE - TRIFLUORIDE

BY

M. C. TANNER

A candidate for the degree of Master of Science

DURHAM COLLEGES IN THE UNIVERSITY OF DURHAM

1955.



ACKNOWLEDGMENTS

I am indebted to Dr. W.K.R. Musgrave who has supervised the work described in this thesis, and whose help and encouragement have been invaluable.

I am also indebted to the Governors of University College Durham for their award to me of a Skene Bursary, to the Sir Richard Stapley Educational Trust, London, for a maintenance grant, and finally to my father, without whose backing it would not have been possible to undertake this work.

CONTENTS

SUMMARY

	Page
I. HALOGENATION WITH CHLORINE TRIFLUORIDE.....	1
Introduction	2
Theoretical	7
Discussion	17
Experimental	31
Experiment No.1... ..	31
" " " 2... ..	32
" " " 3... ..	33
" " " 4... ..	35
" " " 5... ..	36
" " " 6... ..	38
" " " 7... ..	46
" " " 8... ..	50
" " " 9... ..	52
" " " 10... ..	59
" " " 11... ..	61
" " " 12... ..	62
" " " 13... ..	64
" " " 14... ..	69
" " " 15... ..	77

	Page
Experiment No. 16... ..	81
" " " 17... ..	85
II. THE ANALYSIS OF CHLORINE TRIFLUORIDE ...	93
Discussion	94
Experimental	96
III. PRELIMINARY INVESTIGATIONS INTO THE POSSIBILITY OF ANALYSIS OF FLUORINE IN ORGANIC COMPOUNDS BY AN AMPEROMETRIC METHOD	103
Introduction	104
Apparatus and Experimental Procedure ..	110
Results	113
Discussion and Conclusions	115

SUMMARY

I. The action of chlorine trifluoride on trifluoroacetic acid has been studied and it has been shown that the latter is not a suitable solvent for halogenation reactions in which chlorine trifluoride is employed.

The action of chlorine trifluoride on trichloroacetic acid at temperatures ranging from 70°C. to 165°C. has been studied and semiquantitative estimates of the products have been made. It has been shown that under these conditions a free radical mechanism operates and trichloroacetic acid is broken down to give carbon tetrachloride, hexachloroethane, phosgene, trichloroacetyl chloride, chlorine, oxygen, carbon monoxide and carbon dioxide. Other products which may have been formed included monofluorotrichloromethane, carbonyl difluoride, and carbonyl chloride-fluoride.

Trichloroacetyl chloride and trichloroacetyl fluoride have been prepared and their reaction with chlorine trifluoride studied. Whereas the former compound yielded the products as listed above, the latter reacted violently and it was thought inadvisable to proceed further with that line of investigation.

A number of possible reaction mechanisms have been suggested which will account for the formation of the compounds isolated. None of these can be considered proved however in the absence of accurate qualitative results, and to this end suggestions have been made for the improvement of the existing apparatus and of methods for estimating the reactive products.

II. A simple method has been developed for the analysis of chlorine trifluoride in which the vapour, diluted with nitrogen, is passed directly into an alkaline sulphite solution. Fluoride and chloride are determined by standard methods and the ratio Cl:F is calculated.

III. A study has been made of the estimation of fluoride in solution by an amperometric method. The application of this method to the estimation of fluoride in fusion solutions has been attempted, but the results obtained and the detail improvements necessary for accuracy do not justify its use as a routine analytical method.

I. HALOGENATION WITH CHLORINE TRIFLUORIDE

INTRODUCTION, THEORETICAL, ANDDISCUSSIONINTRODUCTION

The original object of this work was to supplement earlier work done at Durham by Ellis and Musgrave (J.C.S. 1950, 3609, 1953, 1063) in which chlorine trifluoride was caused to react with benzene, halobenzenes, and alkyl benzenes in the liquid phase using carbon tetrachloride as an inert non-polar solvent. Ellis showed that both addition to and substitution in the nucleus occurred. The formation of fluorobenzene was accounted for by postulating the reactions

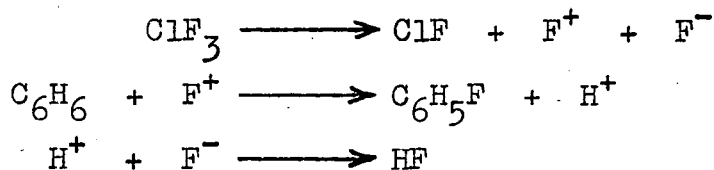

In the case of reactions catalysed with cobalt trifluoride the formation of the positive ion F^+ was again postulated:

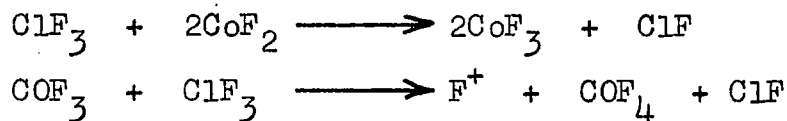

The formation of compounds containing chlorine substituted in the nucleus was accounted for by postulating the



reactions:

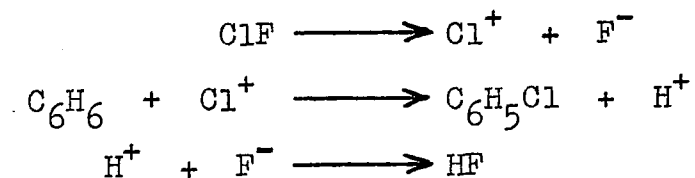

Addition products were assumed to occur via the usual atomic and free radical processes, operating side by side and in competition with the above cationoid substitution processes.

It was decided to conduct a parallel series of experiments using trifluoroacetic acid as a solvent. This polar medium would have been expected to encourage the formation of ions, followed by cationoid substitution reactions. The tendency for free radical processes to occur (addition, fragmentation, dimerisation etc.) would have been expected to decrease.

However, three preliminary experiments with chlorine trifluoride and trifluoroacetic acid showed that losses of up to 50% of the acid occurred either by chemical means or by entrainment of the acid (B.Pt. 72.5°C.) in the stream of chlorine trifluoride and nitrogen diluent. Attention was therefore turned to the nature of the reaction, if any, which occurred between chlorine trifluoride

and trichloroacetic acid. It was hoped that such an investigation would throw light on the general mode of action of chlorine trifluoride, and would in particular explain what was happening in the reaction with trifluoroacetic acid. It was also possible that a new route to trifluoroacetic acid would emerge. Early work showed that acyl halides might be involved in the reaction and accordingly some experiments were later conducted with chlorine trifluoride and trichloroacetyl chloride and trichloroacetyl fluoride. It was thought possible that if the acid itself proved unsuitable as a solvent for halogenation its chloride or fluoride might be satisfactory.

Results showed that both trichloroacetic acid and its chloride and fluoride were broken down completely with the formation for the most part of compounds containing one carbon atom. A small amount of hexachloroethane was also formed in some reactions.

The products identified, and additional ones thought to be possible, are listed in three sections. (See p.p. 17-22 for a discussion concerning the evidence for some of the possible products.)

A. The gases carbon dioxide, carbon monoxide and oxygen, with the possibility of fluorine oxide F_2O .

B. Carbonyl chloride, carbonyl chloride-fluoride, and carbonyl fluoride, with the possibility of trifluoro methyl hypofluorite CF_3OF . Trichloroacetyl chloride, and possibly trichloroacetyl fluoride.

C. Inert compounds, carbon tetrachloride, trichlorofluoromethane, with the possibility of dichlorodifluoromethane. Hexachloroethane.

Not very much is reported in the literature concerning the breakdown of trichloroacetic acid and its halides. Henry (1845) noted that dry distillation of trichloroacetic acid yielded phosgene. (Dyson, Chem. Rev. IV, 110, 1927). Senderens followed the vapour phase decomposition of trichloroacetic acid (Comptes Rendus. 172, 155, 1921.) and tribromoacetic acid (Ibid. 172, 1585, 1921.) in the presence of catalysts such as thorium oxide, kaolin, and animal charcoal. In general, decomposition of trichloroacetic acid started at about 220°C . with the evolution of HCl gas. Other gaseous products of decomposition were CO_2 (64% over thorium oxide and kaolin, 86% over animal charcoal.) and CO (33% over thorium oxide and kaolin, 13% over animal charcoal) and COCl_2 (between 1% and 2% in all cases). Small amounts of chloroform, ethylene tetrachloride and hexachloroethane were also isolated, chloroform being always the major constituent.

Catalytic decomposition in the liquid phase (Senderens, Comptes Rendus. 204, 209, 1937) in the presence of powdered pumice, thorium oxide, tricalcium phosphate, animal charcoal, etc., was found to take place at lower temperatures. In the presence of 15% w/w of tricalcium phosphate or animal charcoal, trichloroacetic acid started to decompose at 135°C. giving HCl, CO₂, CO, COCl₂, and chloroform.

Simons, Sloat and Meunier (J.A.C.S. 61, 435, 1939.) prepared bromotrichloromethane and iodotrichloromethane by passing trichloroacetyl bromide and trichloroacetyl iodide at atmospheric pressure through tubes heated to 400°C. The yields of bromo compound and of iodo compound were 10% and 75% respectively. In both cases about 5% of hexachloroethane was formed, the only other product being carbon monoxide. When trichloroacetyl chloride was passed through the tube a temperature of 600°C. was required before appreciable decomposition took place. Under these conditions one third of the acid chloride decomposed forming carbon tetrachloride and hexachloroethane in 10:1 ratio. Carbon monoxide and phosgene were also formed.

THEORETICAL

From the formation of tetrachloroethylene in Senderens' experiments, and hexachloroethane in the experiments of Simons et al it would seem that the mechanism of both catalytic and thermal decomposition reactions must involve free radicle processes.

A possible mechanism for the thermal decomposition of trichloroacetic acid is as follows:

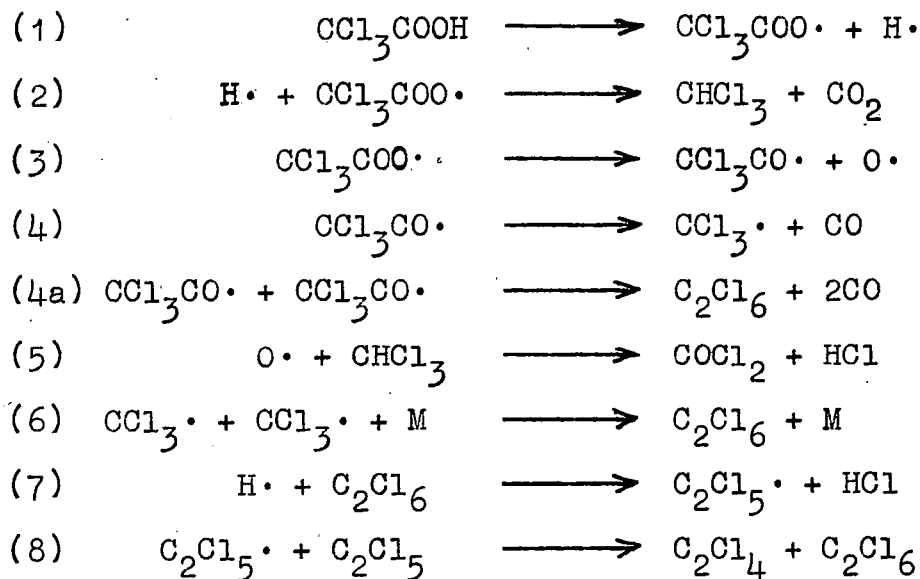

Senderens does not list carbon tetrachloride among the products of decomposition, and its absence is explained by a mechanism which does not involve free chlorine at any point. Steps (1) and (2) are analogous to well established part reactions which occur during the

photolysis of acetic acid vapour. (Burton, J.A.C.S. 58, 692, 1645, 1936.) It is arguable that the CCl_3 -group would reduce the tendency for hydrogen atoms to be split off compared to the effect of the CH_3 - group in acetic acid, and to that extent steps (1) and (2) are speculative. Step (3) is postulatory but the analogous alternative reaction



is known to have a high activation energy. Step (4) is alternative to (4a) but is thought to be a slow reaction with a high activation energy. None of the steps (4) to (8) are quantitatively as significant as steps (1) to (3). Steps (4a), (5) and (6) are well authenticated. Step (7) is postulated on the basis that hydrogen atoms are capable of extracting chlorine from carbon tetrachloride, chloroform, methylene chloride and methyl chloride, hydrogen atoms also extract chlorine from ethyl chloride (Chadwell and Titani, J.A.C.S. 55, 1363, 1933). Step (8) is thought to occur in a number of photochlorination reactions, its activation energy is very low.

If it is assumed that utilisation of oxygen in step (5) proceeds in competition with the reaction

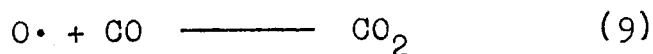

then the relative yields of products by this mechanism agrees with the observations of Senderens, which are in any case only semi-quantitative for the most part.

Simons et al assume for their results that the carbon - carbon bond in trichloroacetyl halides is readily broken under the conditions of their experiments, but it is not necessary to assume that such a fission constitutes a primary step. Jones (J.A.C.S. 61, 3284, 1939.) postulates that fission of the carbon - iodine bond is the primary step in the thermal decomposition of acetyl iodide.

In fact both primary steps can lead to plausible reaction mechanisms.

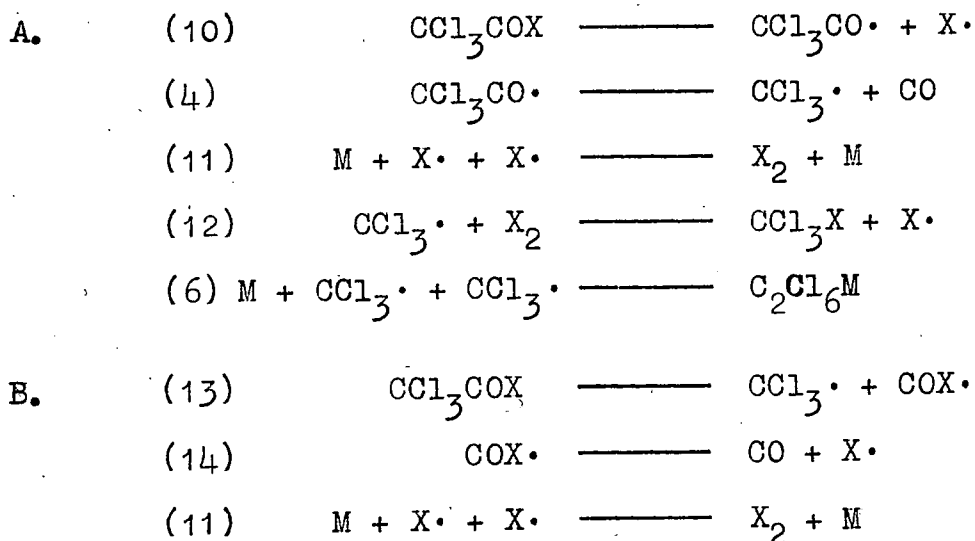

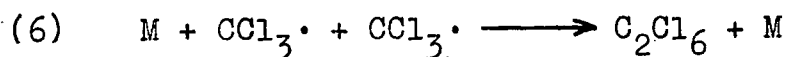
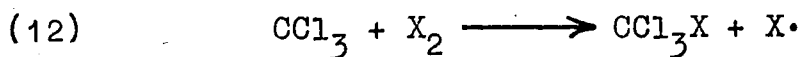

When X is bromine or iodine these reactions are sufficient to account for all the products formed. In the thermal decomposition of trichloroacetyl chloride however some phosgene is also formed, this can arise from either scheme A or scheme B.

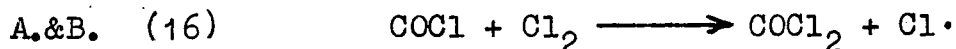

Mechanisms for the reaction between chlorine trifluoride and trichloroacetic acid.

In principle there are two ways of considering the problem. The first is to assume that the same primary steps which operate in the catalytic and thermal decomposition reactions also operate in the presence of an excess of chlorine trifluoride at the much lower temperatures used. Since in all experiments it was possible to detect chlorine trifluoride in the apparatus immediately following the reaction vessel it is reasonable to assume that chlorine trifluoride was always present in excess at the seat of reaction. If it is assumed that chlorine trifluoride is readily dissociated into chlorine monofluoride and

fluorine atoms according to the equation

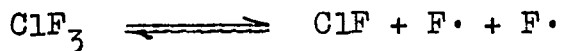

then part reactions with fragments of the trichloroacetic acid molecule can be postulated which account for all the products found. Thus, following steps (1), (3) and (4) above,

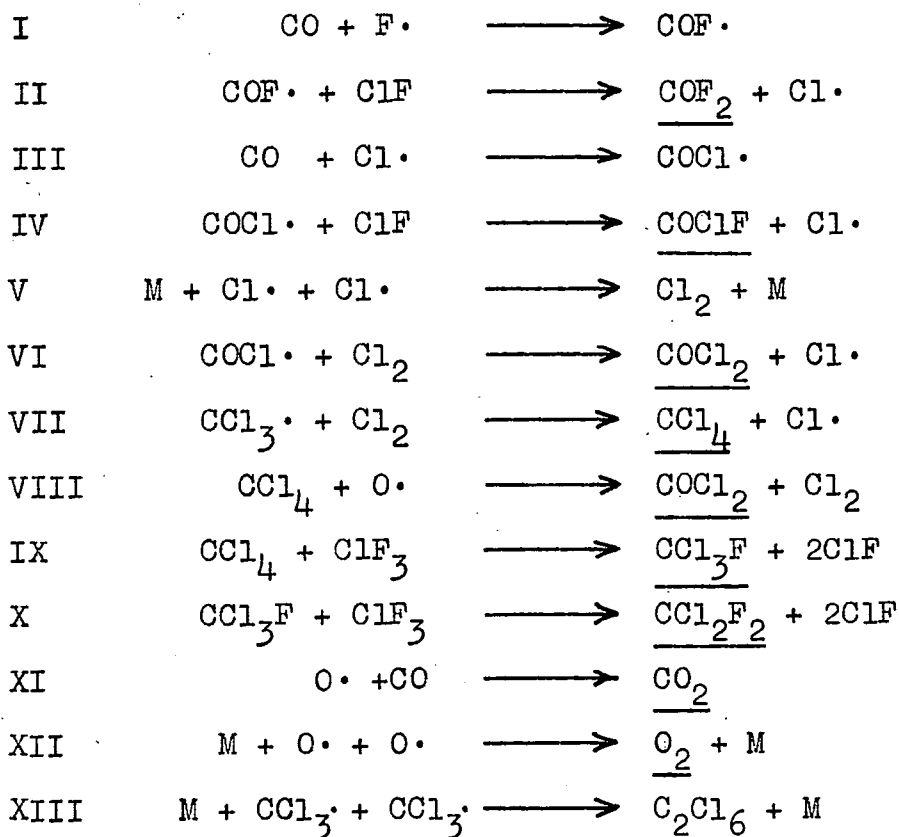

(For internal details of steps IX and X see Ellis and Musgrave J.C.S., 1950, 3609, 1063.)

Steps I - IV and VI are considered to be closely analogous to the accepted Bodenstein mechanism for the photochemical formation of phosgene (Burns and Dainton Trans. Faraday Soc. 48, 39, 1952.)

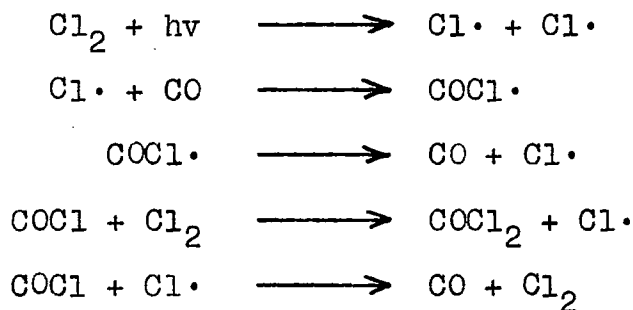

The differences which exist between the experimental conditions of the reaction between chlorine trifluoride and trichloroacetic acid, (80°C. or 100°C., no catalyst) and the conditions described by Senderens (140°C. in the liquid phase, 250°C. in the vapour phase, catalysts) and Simons et al., (400°C., 600°C., no catalyst) are too great to permit the assumption that the primary processes will be the same in each case. Besides, it is to be expected that chlorine trifluoride would play some part in the primary processes.

In view of the lack of published information it is only possible to speculate on the initial mode of action of chlorine trifluoride. However Cady and Kellog

(J.A.C.S. 75, 2501, 1953.) claim that the action of elementary fluorine on trifluoroacetic acid produces the compound trifluoroacetyl hypofluorite, other products being HF, CF₄, COF₂, CO₂ and SiF₄. This reaction occurred in the vapour phase at room temperature so the formation of the single carbon compounds listed above cannot arise from simple dissociation of the trifluoroacetic acid molecule analogous to that postulated above (p.7.) for trichloroacetic acid.

A mechanism can be postulated for this reaction.

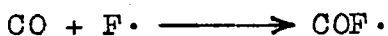
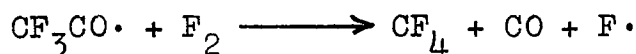
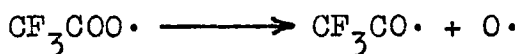
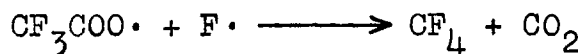
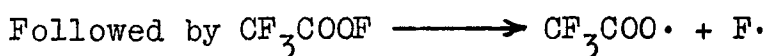
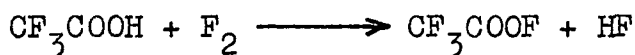

Cady and Kellogg do not appear to have isolated C₂F₆ from the reaction mixture; its isolation would only be likely if free trifluoromethyl radicles were involved in the mechanism. There is evidence that the reaction of trichloroacetyl radicles with chlorine proceeds with a low activation energy, lending some support to the analogous reaction involving fluorine postulated above.

This work suggests that the formation of trichloroacetyl hypofluorite might be a primary step in the reaction of chlorine trifluoride with trichloroacetic acid.

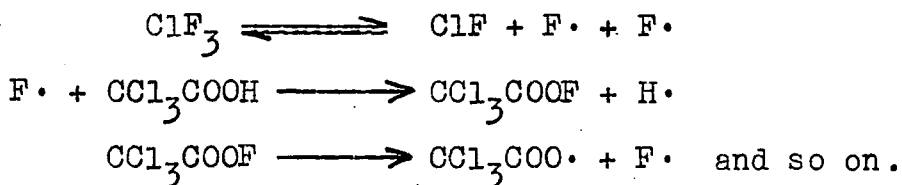

Cady's product was said to be very unstable, so it is not impossible that the existence of trichloroacetyl hypofluorite, if it was ever formed, would be transitory.

A further possibility is suggested by a summary of work done on the photochemical oxidation of monofluoro-dichloromethane sensitised by chlorine (C.A. 1952, 54391. Refers to a summary in German by Schumacher. *Anales asoc. quim. argentina.* 39, 159-74, 1951.)

The following scheme is postulated.

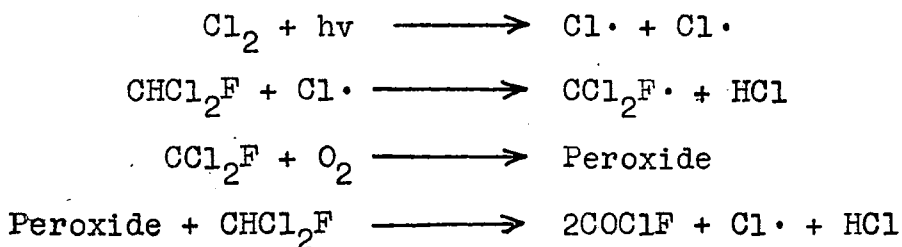

Chlorine atoms carry on the chain. One may suppose that elements of this reaction occur in the interaction of ClF_3 and CCl_3COOH , more particularly since oxygen is known

to be a product.

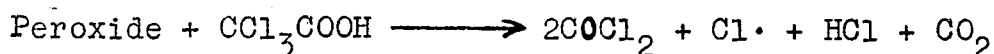

Again chlorine atoms carry on the chain. It is not suggested that this mechanism plays a large part in the overall reaction because the supply of oxygen is limited. Nevertheless some oxidation of the CCl_3 -group must occur to account for the large excess of chlorine ion found in the halogen scrubber in experiment (14).

It is necessary to account for the formation of trichloroacetyl chloride in experiments (4) and (5) and to assign a mechanism to the mode of attack of chlorine trifluoride on this molecule.

Mechanisms which involve oxidation of chlorinated ethylenes or ethanes are well known but would seem to be unnecessarily involved in this instance. Chlorination of the trichloroacetyl radicle is ruled out because two competing reactions would take precedence.

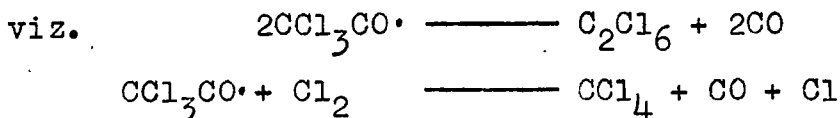

It must be postulated that the formation of trichloroacetyl chloride occurs directly from trichloroacetic acid, or from the radicle $\text{CCl}_3\text{COO}\cdot$.

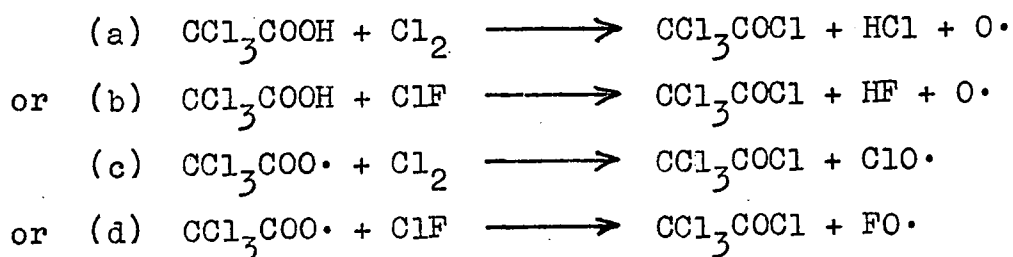

As will be shown later there is indirect evidence that F_2O is not among the reaction products, as would be expected if (d) took place. ($\text{FO}\cdot + \text{FO}\cdot \longrightarrow \text{F}_2\text{O} + \text{O}\cdot$). Further experiments in which HF and HCl can be estimated are necessary before any one of these mechanisms can be put forward with confidence.

The nature of the initial reaction of trichloroacetyl chloride presents less difficulty

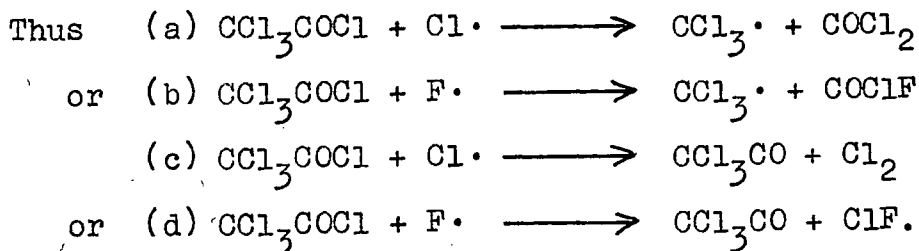

Of these, alternatives (a) and (b) would seem the most likely, no carbon monoxide was ever found in experiments with trichloroacetyl chloride, which throws doubt on (c) and (d).

DISCUSSION OF EXPERIMENTAL RESULTS

A. Gas analysis. The evidence for carbon dioxide, oxygen, carbon monoxide and fluorine oxide.

Although there was always some absorption of gas in 50% KOH it was noted in some later experiments that phosgene (and no doubt its chloride-fluoride and fluoride analogues) was not being quantitatively removed in other parts of the apparatus and that some was travelling as far as the Orsat apparatus (Experiments 14-16). This must necessarily have been absorbed in the first absorption bulb (50% KOH) according to the equation,

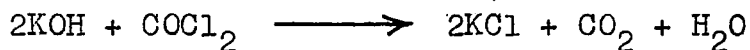

thus giving a spurious value for the amount of carbon dioxide present. In general it must be concluded that the evidence for carbon dioxide is doubtful.

The proportion of gas samples absorbed in the alkaline sodium hyposulphite solution, containing sodium anthraquinone β -sulphonate to increase the rate of absorption, was frequently as much as 20%. At one time it was thought that the absorbed gas might contain fluorine oxide or even to be entirely fluorine oxide since this

compound is quantitatively absorbed in alkaline reducing agents. (Downing, Preparation Properties and Technology of Fluorine and Organic Fluorine Compounds, Chap. 3, p. 75.) However it was noted that samples which had previously been passed through 2N alkaline sulphite solution were absorbed to the same extent as samples which had previously been passed through benzene. This tends to show that fluorine oxide is not present, provided that its absorption in alkaline reducing agents does not produce free oxygen, which seems unlikely.

Carbon monoxide was found on only one occasion. Since it seems unlikely that carbon monoxide is not formed from trichloroacetic acid at least, it must be assumed that once formed it is rapidly halogenated to give phosgene, or carbonyl fluoride, or even trifluoromethyl hypofluorite.

B. Carbonyl chloride, carbonyl chloride fluoride, carbonyl fluoride and trifluoromethyl hypofluorite.

Phosgene was identified beyond doubt (experiment 14) and attempts were made to estimate it (experiments 14-17). There was evidence (experiment 17) that low boiling compounds capable of liberating iodine from potassium iodide and giving fluoride ion in aqueous solution

were also present among the reaction products.

Humiston (J. Phys. Chem., 23, 572-7, 1919) claimed to have prepared carbonyl fluoride by the interaction of fluorine and phosgene at 200°C. in the presence of granulated calcium fluoride. Judging from his figure for the boiling point, (-42°C.) his product seems to have been carbonyl chloride-fluoride. Steinkopf and Herold (J. Prakt. Chem., 101, 79-81, 1920) prepared impure carbonyl fluoride from arsenic trifluoride and phosgene. Ruff and Miltschitsky (Z. anorg. allgem. chem., 221, 154-8, 1934.) after showing that pure carbonyl fluoride could not be prepared from carbon monoxide and fluorine prepared a pure specimen from carbon monoxide and silver difluoride, AgF_2 . It had M.Pt. -114°C. and B.Pt. -83°C. Emeleus and Wood (J.C.S., 1948, 2183-88.) prepared carbonyl fluoride from antimony trifluoride with phosgene under pressure at 280°C. Its reactions with aniline, methyl aniline, diethyl amine, ethyl alcohol, and phenol were studied. Carbonyl fluoride was also formed when carbon monoxide reacted with mercuric fluoride, (Nerdel, Naturwissenschaften, 39, 209-10, 1952) when iodine reacted with sodium trifluoroacetate, the solid mixture being heated with a free flame (Haszeldene, J.C.S. 1951, 584-7) and during the vapour phase fluorination of acetone

(Fukuhara and Bigelow. J.A.C.S., 63, 788-91, 1941), methyl ethyl ketone, or diethyl ketone (Holub and Bigelow. J.A.C.S., 72, 4879-84, 1950).

Carbonyl chloride fluoride was probably prepared by Humiston (loc.cit.) but an unambiguous preparation was reported by Simons Herman and Pearlson, (J.A.C.S., 68, 1672-3, 1946.) who prepared it in 20%-50% yield from phosgene and hydrogen fluoride at 80°C. under a pressure of 280 lbs./sq.in. It had M.Pt. -138°C. and B.Pt. -42°C. Emeleus and Wood (loc.cit.) prepared carbonyl chloride fluoride from antimony trifluoride and a large excess of phosgene in an autoclave at 135°C. This product boiled at -45°C. Its reactions were studied, (Idem. Ibid) and it was found to behave similarly to carbonyl fluoride, forming fluorine rather than chlorine compounds. Schumacher (Loc.cit. p. 14.) reported the formation of carbonyl chloride fluoride during the photochemical oxidation of monofluorodichloromethane.

If it is postulated that carbonyl fluoride can be formed by fluorination of carbon monoxide during the trichloroacetic acid/chlorine trifluoride reaction, then it is in principle possible that fluorination might proceed further with the eventual formation of trifluoromethyl hypofluorite. Kellog and Cady (J.A.C.S., 70, 3986, 1948.)

passed fluorine and methanol vapour, each diluted with nitrogen, into a reactor at 170°C. in the presence of AgF₂. They obtained a product which, after removal of HF, CF₄, F₂O and COF₂, boiled at -94°C. and on analysis corresponded to CF₃OF. Subsequently it was found that carbon monoxide and carbonyl fluoride could both be fluorinated in the presence of AgF₂ to give trifluoromethyl hypofluorite. It was found to react with iodides to give iodine,



and to react with alkali to give oxygen,

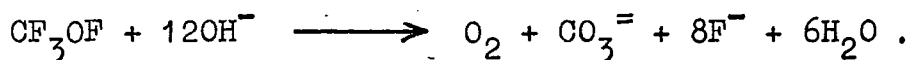

It might be thought that since CF₃OF is absorbed in alkali it could be confused with oxygen in the gas analysis apparatus. However the same objections apply here as to the suggestion that F₂O is among the reaction products. It seems likely that free oxygen would not be formed if CF₃OF were to be absorbed in alkaline sulphite solution.

C. Inert compounds. Hexachloroethane, carbon tetrachloride, and possibly monofluorotrichloromethane.

Two routes are possible for formation of CCl₃F.

a. By stepwise substitution of CCl_4 .

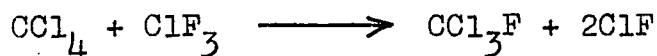

and perhaps $\text{CCl}_3\text{F} + \text{ClF}_3 \longrightarrow \text{CCl}_2\text{F}_2 + 2\text{ClF}$

b. Directly from a trichloromethyl radicle



Since CCl_3F was only ever isolated once and then in very small quantity it may be inferred that formation of freons starts from CCl_4 which would itself be present at the seat of reaction in small amounts only.

The evidence for CCl_4 and C_2Cl_6 is unambiguous and the presence of the latter proves that a free radicle mechanism is operating.

D. Trichloroacetyl chloride was formed, isolated, and characterised. No trichloroacetyl fluoride was ever found and there was direct evidence that no acids or acid halides were formed in which fluorine was substituted for chlorine in the trichloromethyl group.

Before any mechanism can be agreed upon, further quantitative work will have to be done. Such work ought to include:

(a) Estimation of chlorine, phosgene, and of carbonyl

fluoride and carbonyl chloride-fluoride if they are present.

(b) Separation of freons from each other and from carbon tetrachloride followed by estimation of their relative amounts.

(c) Accurate measurement of the gases produced. (CO , CO_2 , and O_2) with checks to determine whether or not fluorine oxide and trifluoromethyl hypofluorite are present.

(d) Development of techniques for isolating hexachloroethane and trichloroacetyl halides from the reaction mixture and each other.

Quantitative work depends in the first place on complete destruction of chlorine trifluoride as it leaves the reaction vessel, without holding back any chlorine or phosgene. This operation is facilitated if a two stage reaction vessel is used but even so there is always some chlorine trifluoride to be destroyed. Organic scrubbers seem to offer the best solution to the problem. Phosgene and its analogues do not react with aromatic hydrocarbons at room temperature; the compound and the conditions can be chosen so that chlorine reacts only partially if at all, while chlorine trifluoride reacts swiftly and completely.

(Ellis and Musgrave. loc.cit.) On the other hand volatile organic scrubbers are ruled out because the vapour becomes entrained in the gas stream and is carried on to the cold traps where it constitutes a nuisance.

Iso-propyl benzene has been used with some success as a chlorine trifluoride scrubber, but some chlorine was held back, both by reaction and in solution. A solid absorbent such as naphthalene or naphthalene di- or tetrachloride should take up chlorine trifluoride efficiently while retaining only small amounts of chlorine. Whatever the organic absorbent selected its amount should be small so that equilibrium between free and dissolved chlorine and phosgene is quickly established, thus minimising the error in subsequent determinations of these bodies.

Alkaline reducing agents and metals such as mercury or antimony must be rejected, since the former destroy both chlorine and phosgene while the latter do not appear to hold back chlorine trifluoride completely.

All apparatus up to and including the chlorine trifluoride scrubber should be of metal. Glass, provided it is dry, is safe but should only be used in work where side reactions leading to the formation of SiF_4 can be tolerated.

Any organic scrubber should be followed by an efficient KF tube to absorb HF. A tube two feet long by one and a half inches wide entirely filled with KF was found to be satisfactory, (experiment (17)). The KF was dried by evacuating the tube and then flaming it vigorously.

A series of bubblers containing alkaline sulphite should run parallel to the chlorine trifluoride scrubber. The lead-in tube to the first of these bubblers, if not to all of them, should be of metal, preferably stainless steel. At intervals the product stream should be diverted through the bubblers, using a mercury cut-off for the purpose (see p. 70), and the total reactive halogen content of the stream determined.

The best way of approach to the operations (a), (b) and (c) above seems to be to condense everything which passes out of the KF tube, using for the purpose two traps cooled in solid CO₂ and two traps cooled in liquid oxygen. Anything passing through the cold traps is directed to an Orsat Apparatus where analyses for oxygen and carbon monoxide are conducted. (It is possible that in experiment (17) oxygen was held in the two nitrogen cooled traps, hence the preference for a liquid

oxygen coolant.) Fluorine oxide, B.Pt. $-145^{\circ}\text{C}.$, can be expected to pass, if present, through the cold traps and be absorbed along with oxygen in the Orsat Apparatus.

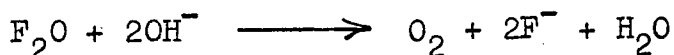

Analysis of the contents of the absorption bulb for fluorine then shows whether fluorine oxide is present or not and, if present, in what quantity.

The condensate remaining in the system of traps can be expected to include phosgene and its analogues, chlorine, carbon tetrachloride and freons, and carbon dioxide. The most satisfactory procedure here is to warm up each trap in turn and destroy chlorine by passing the vapours over mercuric sulphide, antimony sulphide, or the metals themselves. (The free metals are better because the formation of sulphur halides is thereby avoided). The chlorine-free vapour stream is then passed into two bubblers each containing an aqueous solution of aniline saturated with carbanilide, followed by an efficient calcium chloride tube and a further series of cold traps.

Chlorine can then be estimated for each trap by noting successive increases in the weight of the absorption tube. Phosgene and its analogues form carbanilide with

aqueous aniline which can be filtered off, washed, dried, and weighed. Fluoride and chloride ions which are formed concurrently can be analysed.

The carbanilide method for estimating phosgene and its analogues in the presence of other (inert) compounds is preferred to the potassium iodide-iodine-thiosulphate method. (Olsen, Fergusson, Sabetta, and Schefflan, Ind. Eng. Chem. Anal. Ed., 3, 189, 1931).

1. Less handling is involved. (See p. 76.)
2. Inert compounds may be lost in the acetone solution.
3. Acetone may be entrained in the vapour stream and pass into subsequent cold traps.
4. Phosgene reacts with potassium iodide to give carbon monoxide which may pass on and interfere with the separation and estimation of inert compounds and carbon dioxide.



Neither method gives the absolute quantity present of any of the compounds COCl_2 , COClF or COF_2 , but merely a measure of the amount of carbon which appears in these compounds together with the gross amount of chlorine and fluorine which is associated with this carbon.

Low temperature distillation of mixtures of volatile

compounds containing COF_2 , COCl_2 , and HF has been attempted in an all nickel column, (Orrick and Gibson, Anal. Chem. 25, 1100-3, 1953) but the prospect of distilling these compounds apart from each other and from a mixture of freons is not inviting.

Gas chromatography affords an elegant means of effecting the separation, identification, and estimation of carbon tetrachloride and freons. The contents of each of the cold traps following the aqueous aniline bubbler can be passed through the chromatographic column and chromatograms plotted. Since carbon dioxide will have been held in the liquid oxygen trap it will also give a peak on the chromatogram. Any peak which cannot be ascribed to one of the compounds CCl_4 , CCl_3F , CCl_2F_2 and CO_2 might suggest that CF_3OF is present, (see above p. 20) in which case the unknown component can be collected subsequently and examined. A check on carbon dioxide is afforded by collecting it in a reservoir as it comes away from the gas chromatography apparatus and absorbing it in strong alkali.

Trichloroacetyl chloride, and possibly the fluoride, can be expected in the first drikold trap following the reaction vessel. Their transfer from the reaction vessel can be made complete by maintaining a temperature of

about 100°C . both during and for twenty four hours after a reaction and meanwhile blowing a stream of nitrogen through the system. When in due course the first drikold trap is warmed, phosgene will distill off leaving behind a mixture of CCl_3COCl (B.Pt. 118°C .) carbon tetrachloride (B.Pt. 76°C .) and possibly CCl_3COF (B.Pt. 67°C .). Very careful distillation through a column is probably the only satisfactory way of separating these three compounds, unless they are amenable to gas chromatographic methods.

Hexachloroethane was found in experiment (17) as a sublimate in the metal tube connecting the two reaction vessels. Sublimation during the course of the reaction is probably the best way of separating C_2Cl_6 from everything else, and to this end metal connecting tubes should be at least $\frac{1}{2}$ " wide and capable of being scraped out efficiently. Hexachloroethane will also be found in the trichloroacetic acid residue and is best removed by flooding the residue with water. CCl_3COOH is soluble but C_2Cl_6 is not and can be filtered off. It may be purified by dissolving in the minimum volume of methyl alcohol and reprecipitating with water. The precipitate is liable to be very finely divided however.

TABLE OF RESULTS

	16	15	14	13	12	11	10	9	8	7	6	5	4	Reaction No.
			61	32				18	-	51	47	60	-	CCl ₃ COOH
	64	13			31									CCl ₃ COCl
							29							CCl ₃ COF
	40	13	33	25	79	52	26	18	6	20	35	24	5	ClF ₃
	1:4	1:3	1:3	1:3	1.5:2	1.5:1	1.5:1	1:4	1:4	1:4	1:1	1:3	1:5	Ratio ClF ₃ :N ₂
	65°	22°	100°	70°	20°	22°	22°	95°	85°	160°	100°	80°	70°	Temperature
														Products formed
	-	-	-	-	-		-	-	-	*	-	10	7	CCl ₃ COCl
	-	2	5	4	-		-	3	1.5	3	-	-	-	CCl ₄
	*	*	-	?	-		-	-	-	-	-	-	-	C ₂ Cl ₆
	-	-	-	-	-		*	-	-	-	-	-	-	CCl ₃ F
	2.4	1.5	9	*	-		-	-	-	-	-	-	-	COCl ₂
	-	-	-	-	-		-	-	-	-	-	-	-	COClF
	-	-	-	-	-		-	-	-	-	-	-	-	COF ₂
	1.2	3.0	*	-	-		*	-	-	-	*	-	-	Cl ₂
	2.7	2.3	0.7	2.6	-		-	-	-	-	-	-	-	O ₂
	-	-	0.7	-	-		-	-	-	-	-	-	-	CO
	*	-	2.5	2.2	-		-	-	-	-	-	-	-	CO ₂
					20-25 ml. lost by explosion		30 ml.	10-15 ml.	2-3 ml.	20 ml.	15-20 ml.	Not Used	Not Used	Total Volume in cold traps
				18 ml.	Not analysed		Not Used	Not Used	Not Used	Not Used	Not Used	Not Used	Not Used	Halogen Scrubber
	18.2	8.4	11.7											F ⁻ g.
	19.4	8.1	35.0											Cl ⁻

? = Suspected
* = Present but not estimated

Figures given for the wt. of products isolated or estimated are minimum ones and may frequently be less than half of crude wt.

EXPERIMENTAL

This section falls into two parts, a brief description of three early experiments with trifluoroacetic acid followed by details of the remaining experiments with trichloroacetic acid, arranged in chronological order.

Trifluoroacetic acid was prepared by reaction between conc. H_2SO_4 and mixed alkali trifluoroacetates. 270% of the theoretical quantity of H_2SO_4 was added gradually from a dropping funnel to $\text{CF}_3\text{COO}(\text{Na})$ (K) contained in a distilling flask. At temperatures below $90^\circ\text{-}100^\circ\text{C}$ reaction was sluggish, above this temperature CF_3COOH distilled over rapidly, accompanied by small amounts of HF. The temperature was raised until no more material would distill. The crude yellow product was redistilled and CF_3COOH was collected between 71° and 73°C . Yield 77%.

(1) Apparatus. Reaction vessel of 250 ml. capacity in silica with a $\frac{3}{8}$ " silica tube sealed into the side as a gas lead-in tube. Also integral with the reaction vessel was a water cooled silica coil as a reflux condenser leading to a brass trap containing a 4:1

benzene/ CCl_4 mixture, ($\frac{v}{v}$), to absorb excess chlorine trifluoride.

151 gm. CF_3COOH taken.

N_2 flow rate about 11 litres/hour.

ClF_3 flow rate about 1 litre/hour.

Temperature held at 0°C .

12 gm. ClF_3 was introduced over a period of 3 hours.

The residue in the reaction flask was a yellow-green liquid (80 gm.) Distillation gave products boiling from 30°C . to 80°C . the first fractions being yellow-green, the bulk at the higher temperatures colourless. The yellow-green colour disappeared on standing and was ascribed to dissolved ClF_3 or Cl_2 . Redistillation gave unchanged CF_3COOH B.Pt. 72.0°C .

(2) Apparatus. The same as in (1) excepting the water cooled condenser which was replaced by a brass trap cooled in solid CO_2 .

185 gm. CF_3COOH taken.

N_2 flow rate about 10 litres/hour.

ClF_3 flow rate about 1 litre/hour.

Temperature held at 0°C .

4 gm. ClF_3 was introduced during the first hour but the experiment was discontinued because of a leak between the reaction vessel and the cold trap. The contents of the reaction vessel amounted to 175 gm. greenish liquid. This gave 140 gm. unchanged CF_3COOH on first distillation together with 25 gm. yellow-green low boiling liquid, as in (1), and a small amount of unidentified high boiling residue.

(3) The reaction was carried out in the presence of CoF_2 catalyst. This was prepared by the reaction of CoCO_3 with the calculated quantity of 40% HF in a nickel basin. The product was dried over P_2O_5 and used immediately.

Apparatus. As in (2) with the addition of a brass stirrer driven through a carbon tetrachloride seal.

170 gm. CF_3COOH and 20 gm. CoF_2 taken.

N_2 flow rate 11.5 litres/hour.

ClF_3 flow rate 1.5 litres/hour.

Temperature held at 0°C .

16 gm. ClF_3 was introduced during a period of nearly 3 hours. 59 gm. of green-yellow liquid was recovered from the reaction vessel plus a further 20 gm.

of a similar liquid from the cold trap. These were combined and shaken with mercury. By this means most of the colour was removed, confirming that this had been due to ClF_3 or chlorine. Distillation gave 30 gm. boiling below 40°C , the remainder boiling between 40°C . and 70°C . Throughout the distillation quantities of pungent smelling colourless gas which fumed in air were evolved. These fumes were not absorbed by mercury. The fractions obtained above were redistilled separately after standing for 24 hours and both boiled at $70-72^\circ\text{C}$. The distillate was unchanged CF_3COOH .

The gas was thought to be CF_3COF (B.Pt. - 59°C) but CF_3COCl may also have been present. In the presence of ClF_3 , CoF_2 acts as a fluorinating agent. ClF_3 was subsequently found to yield CCl_3COCl by reaction with CCl_3COOH .

It was by this stage evident that CF_3COOH was not a suitable solvent in which to study the reaction between benzene and ClF_3 . Losses due to entrainment of the acid in the gas stream occurred even at 0°C ., and reaction between ClF_3 and CF_3COOH was

prohibitive. Succeeding experiments were designed to yield information about the mode of reaction of ClF_3 with CCl_3COOH which is more readily available than CF_3COOH and much less volatile.

Trichloroacetic acid has M.Pt. 57°C . and B.Pt. 197°C . Before use it was purified by distillation under reduced pressure. ($89^\circ - 91^\circ\text{C}/24$ mm. Hg, $85^\circ - 87^\circ\text{C}/16$ mm. Hg) CCl_3COOH , like CF_3COOH , absorbed moisture readily and had to be kept in sealed containers.

In previous experiments it had been shown that pyrex glass would withstand attack by ClF_3 for several hours provided that apparatus and reagents were completely dry. It was decided to use pyrex apparatus in future experiments (it is much more easily worked than silica), discarding any vessels which became dangerously etched through prolonged exposure to ClF_3 .

(4) Apparatus. Pyrex 100 ml. three necked flask with three B 14 sockets which carried lead in tube, thermometer well, and a double surfaced reflux condenser. The condenser was connected to a bubbler containing a 4:1 mixture of CCl_4 /benzene, ($\frac{1}{v}$), and the

reaction vessel was heated on an oil bath.

62 gm. CCl_3COOH taken.

N_2 flow rate 2.5 litres/hour.

ClF_3 flow rate approximately 0.5 litres/hour.

Temperature held at $70^\circ - 75^\circ\text{C}$.

5 gm. ClF_3 was introduced during a period of about $2\frac{1}{2}$ hours. This time included stoppages to repair leaks. The residue in the reaction flask was a pale yellow liquid at room temperature. This was distilled through a 7" Vigreux column giving 10 gm. boiling below 120°C ., the remainder boiling above 120°C . and solidifying in the condenser. The lower boiling fraction was redistilled and gave 7 gm. B. from 101°C . to 107°C .

This product was a colourless liquid with a pungent smell, fuming slightly in air. It was acid to litmus and did not react with mercury. Samples contained appreciable amounts of free F^- and Cl^- , and had all the attributes of an acyl chloride.

(5) Apparatus. Pyrex 250 ml. three necked flask with two B 14 sockets for lead-in tube and thermometer well, and a B 29 socket carrying a large adaptor and reflux condenser leading to a bubbler as before. The

adaptor was included to reduce the chance that sublimed CCl_3COOH might block the base of the reflux condenser.

210 gm. CCl_3COOH taken.

N_2 flow rate 2 litres/hour.

ClF_3 flow rate 1 litre/hour.

Temperature held at 80°C .

24 gm. ClF_3 was introduced in 9 hours with three interruptions for leaks. The temperature inside the reaction vessel rose 2°C . above that of the oil bath for most of the time, suggesting an exothermic reaction. The residue amounted to 150 gms. material, which solidified on cooling. Distillation gave 30 gms. pungent smelling colourless fuming liquid boiling between 100° and 120°C . This was left standing over MgSO_4 and then redistilled twice through a small packed column. Finally 10 gms. was obtained boiling between 110° and 116°C . The remainder was unchanged CCl_3COOH .

The product boiling from 110° to 116°C . was identified as trichloroacetyl chloride.

The anilide was prepared by suspending 2 gm. aniline in excess 2N alkali and adding excess trichloroacetyl chloride. The mixture was shaken vigorously

until a white solid formed. (Schotten-Baumann conditions). The solid was filtered off, washed with water, recrystallised twice from aqueous alcohol, washed with water each time, and finally dried over P_2O_5 .

<u>CCl₃COCl</u>	<u>Requires</u>	<u>Found</u>
B.Pt.	115°-118° (various authors)	110°-116°C.
E.W.	182	193
Cl ⁻ on hydrolysis	19.5%	19.5%
M.Pt. of Anilide	94°-95°C.	94°C

(6) Apparatus. As in (5) with the exception that the reflux condenser led to three pyrex traps cooled in solid CO_2 /alcohol mixture.

200 gm. CCl_3COOH taken.

N_2 flow rate $1\frac{1}{2}$ litre/hour, reduced to zero for the last $1\frac{1}{2}$ hours.

ClF_3 flow rate 1 litre/hour, increased to $1\frac{1}{2}$ litre/hour for the last $1\frac{1}{2}$ hours.

Temperature held at 100°C.

Four hours after the start of the experiment the temperature of the reaction mixture was 105°C, and it remained 5°C. above the oil bath temperature until the experiment finished.

35 gm. ClF_3 was introduced during a running time of 9 hours.

Working up procedure

1. Residue in the reaction vessel, 153 gm. This was distilled and yielded nothing boiling below $84^\circ\text{C}/16$ mm. i.e. it was all trichloroacetic acid.

2. Contents of the first cold trap. This amounted to 15-20 ml. of clear yellow-brown liquid, nothing had collected in the second and third traps. The liquid was assumed to contain dissolved ClF_3 and it was resolved to destroy this by distilling slowly through a mixture of benzene in CCl_4 , collecting volatile compounds in a cooled trap on the far side. This operation gave 2-3 ml. yellow-green low boiling liquid in the further cold trap, left a mushy residue smelling of acyl halide in the original trap, and turned the benzene/ CCl_4 mixture yellow-brown. This last was treated with solid KF to remove any HF formed by reaction of ClF_3 with benzene, decanted off, and distilled through a small packed column leading via a water cooled condenser to a trap cooled in solid CO_2 . 15 ml. of green-yellow distillate was obtained in this trap, looking in all respects identical to the small amount collected before.

The green colour was thought due to free chlorine, and the remaining component/components were assumed to be acyl halides. The whole boiled below room temperature.

The reaction of a sample of this liquid with water was vigorous, resulting in the evolution of HF. The mixture was allowed to warm slowly to room temperature after which qualitative tests for Cl^- and F^- , gave positive results. Attempts to form S-benzyl thiouronium derivatives of the acids, assumed to be present after the hydrolysis above, failed.

The addition of precooled ammonia to a sample resulted in a vigorous reaction, and eventually explosion on warming to room temperature. Addition of precooled alcohol had the same effect.

Experiments (4), (5) and (6) provided evidence for the formation of CCl_3COCl at 70°C . to 80°C ., and suggested that elementary chlorine, together with low boiling acyl halides, both chloride and fluoride, were formed. The next experimental work was directed to finding a method for separating and characterising low boiling mixtures assumed to contain acyl chlorides and

and fluorides and free chlorine. Such compounds, derived from CCl_3COOH are:

CCl_3COCl	B.Pt. 118°C .	CCl_3COF	B.Pt. $66^\circ-68^\circ\text{C}$.
CCl_2FCOCl	$70^\circ-75^\circ\text{C}$.	CCl_2FCOF	$25^\circ-40^\circ\text{C}$.
CClF_2COCl	34°C .	CClF_2COF	$-20^\circ-0^\circ\text{C}$.
CF_3COCl	$-18^\circ-19^\circ\text{C}$.	CF_3COF	-59°C .

With the possible exceptions of CCl_3COCl , CCl_2FCOCl and CCl_3COF , all of these might be found in the low-boiling mixture.

The first method which suggested itself was low temperature fractional distillation. For the best results a column of the Poelbielniak type should be used in which the temperature of the vacuum jacketed packed column and of the still-head, can be closely controlled and adjusted, preferably by automatic means. A simpler column has been described by Simons (Ind. Eng. Chem. Anal. Ed. 1938, 10, 648) in which the temperature of the reflux "cold finger" is varied by varying the rate at which air is drawn through first a coolant and then through the cold finger itself. The temperature of the packed column is determined by the depth to which it is immersed in a tall Dewar vessel containing a small amount of liquid nitrogen at the bottom.

Ramler and Simons (Ind. Eng. Chem. Anal. Ed. 14, 430, 1942) describe a column in which there is no control of the reflux temperature at all. Columns of this simplicity will only work efficiently where the compounds, not more than two or three at the most, have known boiling points which are 20°C. or more apart. Ellis was able to separate CCl_3F , (B.Pt 24°C.) from CCl_2F_2 , (B.Pt. - 28°C.) and both from CCl_4 (B.Pt. 76°C.). Typical results were 2.3 ml. CCl_2F_2 followed by 1.2 ml. of intermediate fraction boiling between -14°C. and + 9°C., and finally CCl_3F (Ellis and Musgrave, J.C.S. (1953), 1063). It was thought that efficient fractionation of the sort of mixture suggested above would be doomed to failure from the start.

A compromise method which was then considered involved recognition that the low boiling mixture could not be efficiently separated into its components using the simple low-temperature fractionation apparatus available. It was decided to esterify the mixture and fractionate the resulting mixture of esters. Halogen analysis of pure fractions would then show whether fluorine had been substituted in the CCl_3 -group, but no differentiation between acid fluorides and acid chlorides would be obtained.

Information was sought on columns with the usual desiderata, low hold up and high efficiency combined with reasonable throughput and ease of construction. (A charge of approx. 30 mls. requires a hold up of less than 3 ml., an efficiency of 20-30 plates, and a throughput such that the charge can be fractionated inside 20 hours, i.e. $1\frac{1}{2}$ ml/hour).

Two columns were selected for consideration.

1. Coiled coil column (Sherland, J. Applied Chem. 1952, p. 438). A length of 24 s.w.g. nichrome wire was wound tightly on to a stout steel piano wire so that a long coil of about 3 mm. diam. was obtained. The steel core was removed and the coil stretched so that the distance between turns was approximately the thickness of the wire. A similar coil of 24 s.w.g. copper wire was made, but wound in the opposite sense. The two coils were then wound together on to a closed glass tube of 49 cm. length, the visible result being alternate coils of Ni and Cu wire. Finally a second glass tube was slipped over the coils and was shrunk on to the wire by carefully heating the whole in a brush flame. The copper coil was then dissolved out with nitric acid leaving an evenly spaced coiled coil of nichrome wire (Fig. 1). Ground glass joints were attached at both ends of the outer tube.

The still pot was wound with 5 yds. of 23 ohm nichrome heating tape giving a resistance of 115 ohms. The column jacket also took 5 yds. of nichrome tape giving the same resistance 115 Ω . In operation, the still pot was placed in series with a resistance of 130 ohms, and the jacket was placed in series with a resistance of 160 ohms. Both circuits were controlled by Simmerstats.

On a test mixture of benzene and carbon tetrachloride, both previously dried and redistilled, the column after preflooding had an efficiency of 20 plates at a continuous take-off rate of 18 ml./hour. (H.E.T.P. = 2.45 cm.). The total hold-up was prohibitively high however (Static hold-up was approx. 1.0 ml., dynamic hold-up was 11.5 ml.).

2. It has been shown that the column with least hold-up is the concentric tube column. Most workers insist however that the column be made of precision bore glass tubing, and that the conditions for optimum performance are critical. Nevertheless it was decided to construct a concentric tube column from ordinary pyrex glass tubing, with a simplified reflux distributor at the top, and no vacuum jacket (Fig. 2). The length of the concentric section was 49 cm. Inner tube O.D.



INNER TUBE SUPPORTED ENTIRELY BY COILS OF 24 S.W.G. NICHROME WIRE

FIG. 1.

COILED COIL COLUMN.



REFLUX DISTRIBUTOR AND SUPPORT FOR INNER TUBE.

LENGTH OF CONCENTRIC PORTION 49 cm.

ANULAR GAP 1.25 mm.

SUPPORT FOR INNER TUBE

FIG. 2

CONCENTRIC TUBE COLUMN.

was 14 mm., outer tube I.D. was 16.5 mm., giving an annular gap of 1.25 mm.

The still pot was heated by a 60 watt isomantle, whose power output was controlled by a small Variac (max current 2 amp.) The column jacket was wound with 11.7 yds. of 23 ohm nichrome heating tape, giving a resistance of 270 ohm, this was placed in series with a 160 ohm resistance and the whole was controlled by a Simmerstat.

On a test mixture of benzene and carbon tetrachloride the column ran with an efficiency of from 13 to 15 plates. (H.E.T.P. = 3.5 cm.) The reflux rate at the base of the column was between 50 and 60 ml. per hour. The static hold-up of the cold column was 0.6 ml., the dynamic hold-up was less than 2.0 ml. The column was easy to operate and it has since been successfully used by other workers in this laboratory for routine fractionations.

It was decided to conduct a further halogenation experiment in which any low boiling products would be combined, esterified, and subsequently fractionated.

(7) Apparatus as in (5) and (6), but with only two cold traps.

86 gm. CCl_3COOH taken.

N_2 flow rate 2.0 litre/hour, reduced to zero after first four hours.

ClF_3 flow rate 2 gm./hour for the first four hours, slightly less for the remainder of the experiment.

Temperature held at 160-165°C. throughout the run.

20 gm. of ClF_3 was introduced during a running time of 13 hours

Working up. The solid residue in the reaction flask amounted to 33 gm., this was assumed to be mostly unchanged CCl_3COOH with small amounts of the acid chloride and possibly smaller amounts of other acid halides. It was refluxed for $4\frac{1}{2}$ hours with a 200% excess of absolute alcohol plus two drops of conc. sulphuric acid on an oil bath whose temperature was gradually allowed to rise to 140°C. The liquid residue was then washed with water, the insoluble ester/s were separated and dried over anhydrous MgSO_4 . The product was a heavy yellow liquid with the usual ester-like smell, wt. 28 gm. It was put aside for fractionation.

About 20 ml. of yellow-brown liquid was present

in the first cold trap. The trap was warmed carefully and the contents distilled, material boiling below room temperature was collected in a further cooled receiver. The remainder, wt. 16 gm., was carefully distilled from a small claisen flask with fractionating side arm. The distillate included 9-10 gm. boiling below 70°C . and 5.5 gm. boiling between 74°C . and 77°C . The latter fraction was a colourless mobile liquid with a pungent acid smell, fuming slightly in air. It was of great interest because CCl_2FOCCl was known to boil from 70°C . to 75°C .

Accordingly attempts were made to estimate its equivalent wt. as had been done for CCl_3COCl in (5). These attempts failed and it was shown that the bulk of each sample was an inert, neutral compound. The bulk of the material boiling between 74°C . and 77°C . was therefore washed with dilute carbonate solution and dried over anhydrous MgSO_4 . Redistillation gave 3 gm. boiling from 76° - 77°C . Its refractive index was 1.4600 at 21°C . and judging by its characteristic smell it was CCl_4 . The published figure for the refractive index is 1.4630 at 15°C .

There remained the liquid boiling between room temperature and 70°C ., and that boiling below room temperature. The former was distilled onto a small excess of alcohol and the whole was then refluxed for three

hours, washed with water (insoluble layer heavier than water) and dried over anhydrous MgSO_4 . Wt. 3 gm. (A). The latter was distilled onto a small excess of alcohol in a drikold trap, warmed carefully to room temperature, and finally refluxed for three hours under a water cooled double surfaced condenser topped by a cold finger containing a slush of solid CO_2 /alcohol. During the refluxing period HCl was evolved and identified as such. The residue was then washed with water (colourless insoluble layer lighter than water) and dried over anhydrous MgSO_4 . Wt. 3 gm. (B).

(A) and (B) were separately distilled from small claisen flasks. In both cases distillate was collected continuously over a boiling range from 55°C . to 125°C . Cuts were made in each distillation and samples of each fraction were analysed for Cl and F.

TABLE (A)

	Distillate boiling range	Bath Temp.	Amount	% Chlorine	% Fluorine
1	$60^\circ\text{--}85^\circ\text{C}$.	110°C .	0.5 gm.	38	Trace
2	$85^\circ\text{--}105^\circ\text{C}$.	$110^\circ\text{--}150^\circ\text{C}$.	0.5 gm.	7	Trace
3	$105^\circ\text{--}123^\circ\text{C}$.	$150^\circ\text{--}160^\circ\text{C}$.	0.5 gm.	23	Trace
4	Above 123°C .	160°C .	0.5 gm.	5	Trace

TABLE (B)

	Distillate boiling range	Bath Temp.	Amount	% Chlorine	% Fluorine
1	55 ^o -65 ^o C.	100 ^o C.	4-5drops	3	Trace
2	65 ^o -120 ^o C.	100 ^o -140 ^o C.	1 gm.	30	None
3	120 ^o -125 ^o C.	140 ^o C.	1 gm.	5	None

The residues from (A) and (B) remaining after analysis, amounting to no more than 2 gm., were combined with the ester mixture derived from the solid residue in the reaction flask, and subjected to fractionation in the 49 cm. concentric tube column. It became necessary to leave the mixture under reflux overnight and the bulk of the distilland was unfortunately lost via. a leak at the top of the column. It was already evident however that the bulk of the material present was trichloroacetic ester (B.Pt. 164^oC.).

It was concluded from this experiment that substitution of fluorine into the CCl₃-group does not occur. The formation of CCl₄ suggested that an atomic free radicle mechanism was at work.

(8) Reaction of ClF₃ with CCl₃COOH in the presence of cobalt fluoride.

Apparatus. A pyrex 250 ml. conical flask with three necks was employed. The three necks carried lead-in

tube, thermometer well and reflux condenser as before. The condenser led to the usual train of cold traps. The base of the flask was wound with nichrome tape and heating was controlled by a Simmerstat. The flask was mounted on a Towers magnetic stirrer base and the contents were agitated by the movement of a length of glass tube (7 mm. O.D.) with a small magnet sealed in.

108 gm. CCl_3COOH taken.

20 gm. CoF_2 taken (prepared as in (3) above).

N_2 flow rate 4 litres/hour, later reduced to 2 litres/hour.

ClF_3 flow rate variable owing to continuous trouble with the flowmeter.

Temperature held at $80^\circ\text{-}90^\circ\text{C}$.

Only 6 gm. of ClF_3 was introduced at intervals during the course of two days, during actual running times the flow rate was about 1 gm./hour. Temperature control was difficult because the stirrer base tended to warm up appreciably after a period. In spite of this it seemed that an endothermic reaction was taking place. On more than one occasion it was noticed that the passage of ClF_3 into the reaction vessel for only 45 minutes lowered the temperature by as much as 10°C . (Cf. an analogous reaction in reverse,

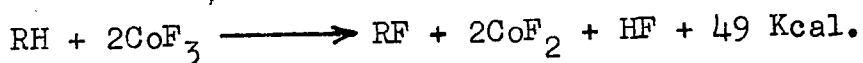

Haszeldine and Sharpe. Fluorine Chemistry, p. 130).

The liquid residue was decanted from unchanged CoF_2 while still warm, and distilled from a claisen flask. Nothing distilled below 160°C . at which temp. CCl_3COOH began to come over.

2-3 ml. of yellow green liquid was found in the first cold trap. This was warmed carefully to remove any dissolved ClF_3 . Distillation yielded 2 gm. boiling between 60°C . and 77°C ., which on redistillation gave 1.5 gm. CCl_4 B.Pt. $76^\circ-77^\circ\text{C}$.

It was noted that when CoF_2 was added to CCl_3COOH and the temperature raised to 80°C . fumes of an acid halide **type** were blown out of the train on the N_2 stream. This can only have been CCl_3COF (B.Pt. $66-68^\circ\text{C}$.). No CCl_3COF was found among the reaction products.

(9) Apparatus as in (6) and (7) with the reflux condenser replaced by a wide vertical tube leading to the first cold trap.

40 gm. CCl_3COOH taken.

N_2 flow rate 3 to 4 litres/hour.

ClF_3 flow rate 1 litre (4 gm.)/hour.

Temperature held at 90° to 100°C .

18 gm. of ClF_3 was introduced during $4\frac{1}{2}$ hours running time. The solid residue in the reaction flask amounted to 22 gm. Distillation yielded nothing but unchanged CCl_3COOH .

The first cold trap contained 10-15 ml. of yellow brown liquid. This was allowed to warm slowly to room temperature to allow dissolved ClF_3 to escape. The remaining liquid (7-10 ml., pale green) was distilled from a small claisen flask. Distillate came over continuously from 25°C . to 75°C . but the bulk came over between 65°C . and 75°C . The latter was assumed to be CCl_4 and was accordingly washed with dilute carbonate solution. Some reaction occurred and CO_2 was evolved. About half of the distillate was lost in this way, tests on the aqueous layer revealed the presence of both Cl^- and F^- ions. The remaining insoluble liquid was washed, dried over anhydrous MgSO_4 and redistilled. This gave B.Pt. $76-77^\circ\text{C}$. and $n_D^{20.5} = 1.4600$ and was carbon tetrachloride (3 gm.).

Subsequent experiments showed that COCl_2 and possibly COF_2 were formed in this reaction, which may explain the acid constituent of the distillate. If one can assume that the reaction chain

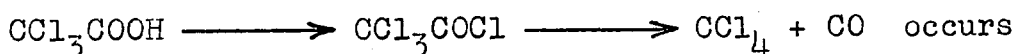

then one would expect greater yields of CCl_4 from an experiment starting with CCl_3COCl , and CCl_3F from an experiment starting with CCl_3COF . Experiments were designed in which the acid chloride and fluoride were used, and these compounds were prepared.

Trichloroacetyl chloride CH_3COCl

Standard methods for the preparation of acid chlorides use PCl_5 , POCl_3 , PCl_3 or SOCl_2 as the source of chlorine.

1. PCl_5 . Equimolecular quantities of the acid and PCl_5 are used. By-products are HCl and POCl_3 , the latter must be removed either by heating the reaction mixture to 120°C . in a stream of N_2 or evaporating under reduced pressure at temps. between 80°C . and 100°C . This method cannot therefore be used when the acid chloride distills below about 150°C . at atmospheric pressure.

2. PCl_3 . for volatile acid chlorides. The main product besides R.COCl is orthophosphorous acid H_3PO_3 , but some HCl is always formed together with volatile phosphorous compounds.

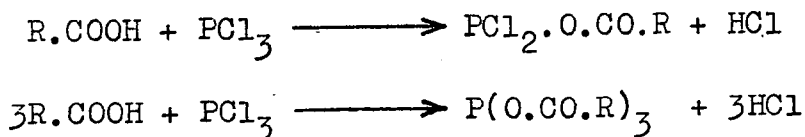

3. POCl_3 , for the preparation of very pure acid chlorides

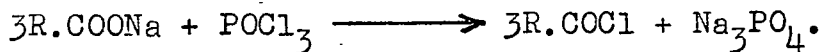

4. SOCl_2 . By products are gaseous, but since the reagent is generally used in excess, unused SOCl_2 (B.Pt. $76^\circ\text{C}.$) must be removed by fractionation. The method cannot therefore be used for acetyl ($52^\circ\text{C}.$), propionyl ($80^\circ\text{C}.$), isobutyryl ($92^\circ\text{C}.$) or oxalyl ($65^\circ\text{C}.$) chlorides. Yields of acid chlorides vary with the source of chlorine and the acid.

Cf. 67.5% CH_3COCl from CH_3COOH with PCl_3

63% CH_3COCl from CH_3COOH with POCl_3 .

87% $\text{CH}_3(\text{CH}_2)_2\text{COCl}$ from $\text{CH}_3(\text{CH}_2)_2\text{COOH}$ with SOCl_2 .

90-96% $\text{p-NO}_2\text{C}_6\text{H}_4\text{COCl}$ from $\text{p-NO}_2\text{C}_6\text{H}_4\text{COOH}$ with PCl_5 .

92% sym. phthalyl chloride from the anhydride with PCl_5 .

An interesting method for preparing acid chlorides is referred to in C.A. 24, 61, (1930) (Rabcewicz and Zubkowski). These authors state that chlorinated aromatic hydrocarbons containing the group $-\text{CCl}_3$ will react with acids or anhydrides in the presence of catalysts such as ZnCl_2 , or even in their absence, forming the corresponding acid chloride in almost quantitative yield.

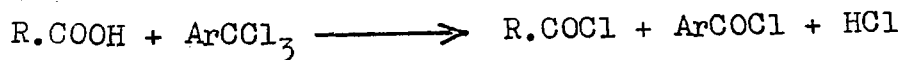

It is stated that CH_2ClCOCl is formed in 90% yield from CH_2ClCOOH by this method.

No experimental details are quoted in the abstract and although the method has been used with success in this laboratory no detailed account remains. It was decided to try this method for trichloroacetyl chloride.

500 gm. benzotrichloride (2.55 mole) was added dropwise to 420 gm. trichloroacetic acid (2.55 mole) and 25 gm. of anhydrous ZnCl_2 (0.18 mole) contained in a 1 litre flask. The flask and contents were refluxed for 4 hours on an oil bath at 150°C ., at temperatures over 100°C . HCl was evolved rapidly. After leaving overnight a further 100 gm. $\text{C}_6\text{H}_5\text{CCl}_3$ was added slowly and refluxing continued for a further 4 hours at 150°C ., by which time the evolution of HCl was negligible. The apparatus was then arranged for distillation and the temp. slowly raised to 180°C .; 314 gm. of crude CCl_3COCl was collected in this way. This was redistilled from a claisen flask with fractionating side arm, collecting 270 gm. boiling between 118°C . and 120°C . (58% of theory).

The residue in the reaction flask stood for a week at room temp. and was then heated on an oil bath

to 195°C. (Benzoyl chloride boils at 197°C.).

Distillation commenced at 175°C. and heating was discontinued when no more product would distill at 195°C.

The distillate amounting to 120 gm. was redistilled, and 92 gm. of CCl_3COCl was collected between 118°C. and 120°C.

The total yield was then 362 gm., 78% of theory.

Trichloroacetyl fluoride

Haszeldine and Sharpe, "Fluorine and its compounds" p. 70, state that reactive chlorine atoms as in acyl and sulphonyl chlorides can be replaced by fluorine with almost any inorganic fluoride. Hickinbottom, "Reactions of Organic Compounds", p. 258, 260, lists a number of such methods, the metal fluoride used being silver, arsenic, antimony, zinc or potassium fluoride.

Acyl fluorides have also been prepared from the free acid or its salts by distillation with fluorosulphonic acid or its salts respectively. They have also been prepared by the action of HF on the acid anhydride.

Two general methods of preparing acyl fluorides are described by Mashentsev. In the first (C.A. 1948, 5418a) it is shown that attempts to prepare acid fluorides

from non metallic fluorides and/or oxyfluorides and the carboxylic acid should not succeed. A synthesis is then described in which the acid is first converted to the acid chloride by treatment with suitable non-metallic chlorides or oxychlorides, SOCl_2 , COCl_2 , $(\text{COCl})_2$, and then converted to the fluoride by treatment with an alkali fluoride. e.g. AcOH was treated with SOCl_2 and after the initial reaction had subsided the mixture was heated for 1.5 to 2 hours to drive off SO_2 and HCl . An alkali fluoride was then added to the cooled mixture and AcF was distilled into a cooled receiver. This product contained some AcCl which was removed by distillation. Figures are quoted showing the relative efficiencies of alkali fluorides, based on the amount used. Yields of acyl fluoride vary from 24% using NH_4F to 54% using KHF_2 or 60% using KHF_2 when 10% acid anhydride is present. The reaction is best conducted in two separate stages as described since addition of alkali fluoride to the acid and SOCl_2 precipitated an inert complex.

The second method, (C.A. 41,706f.) involves reaction of benzoyl fluoride with the appropriate acid followed by distillation of the mixture to give the acid fluoride. Since benzoyl fluoride was not itself available the method was not considered further although a 43% yield of CCl_3COF direct from the acid was claimed.

It was decided to attempt the preparation of CCl_3COF on the basis of Mashentsev's first method, using KF and the acid chloride already made. The KF was dried before use by heating for 15 hours under reduced pressure at 184°C .

105 gm. (1.8 mole.) of KF and 328 gm. (1.8 mole.) of CCl_3COCl were placed in a 500 ml. three-necked flask which had two vertical creases at opposite sides to act as baffles. The flask was provided with thermometer, reflux condenser and stirrer. The contents were stirred together for 10 hours at 125°C . after which time a very considerable reflux was observed in the condenser. The coolant was removed and product was allowed to pass over into a series of traps cooled in ice. During collection of product (4 hours) the temperature was allowed to remain at 105°C . The crude product, which amounted to about 100 ml. was redistilled twice, collecting between 69.5°C . and 70.5°C . the second time.

The yield of CCl_3COF was 107.5 gm., the percentage yield w.r.t. CCl_3COCl was 36%, that w.r.t. KF was 38%.

(10) Experiment with CCl_3COF . Since CCl_3COF is a volatile liquid it was decided to use a two stage reaction

vessel, the second bulb of which was connected via the usual reflux condenser to a series of cold traps. The second bulb was also provided with a thermometer well.

75 gm. CCl_3COF taken.

N_2 flow rate 1 litre/hour, kept to a minimum to avoid entrainment.

ClF_3 flow rate $1\frac{1}{2}$ litre/hour.

Temperature: room temperature $22^\circ\text{-}24^\circ\text{C}$.

26 gm. of ClF_3 were used during a running time of $4\frac{1}{2}$ hours. A strongly exothermic reaction was observed to take place, the temp. registered in the second stage of the reaction vessel being 26°C . above the ambient temperature at the conclusion of the experiment. When ClF_3 and N_2 had both been turned off a vigorous reaction persisted in the second bulb.

Working up. 44 gm. greenish coloured liquid was recovered from the reaction vessel. Distillation caused half to come over from $40^\circ\text{-}65^\circ\text{C}$. and the remainder from $65^\circ\text{-}70^\circ\text{C}$. The green colour was due to dissolved chlorine and persisted in the first half of the distillate.

The first cold trap contained 30 ml. of red-brown liquid. When this was warmed cautiously to room temperature about 7 ml. distilled off and was collected in a trap

cooled in CO_2 . The remainder was coloured green and was shown to be almost entirely CCl_3COF , the chief impurity being chlorine. The low boiler was distilled three times through 25 ml. portions of 2N alkaline sulphite. At each operation about half was absorbed, the remainder was equally divided between a residue which boiled at room temp., and a low boiling body which could be collected at the far side of the alkaline sulphite bubbler in a trap cooled in CO_2 . The former was inert, insoluble in water, and colourless. With its boiling point very close to room temperature it was very probably CCl_3F (B.Pt. 24°C). The three portions were combined, distilled through a CaCl_2 tube, collected in a cooled tube, and sealed up. Two subsequent analyses for Cl and F showed the presence of both but the figures cannot be relied upon. The low boiling body, by now reduced in volume to a fraction of a ml. by progressive absorption in the alkaline sulphite, was coloured green and was almost certainly chlorine. Addition of samples of the alkaline sulphite solution to a solution of KI liberated iodine.

(11) Experiment with CCl_3COF

Apparatus, as in the previous experiment. 60 gm. of CCl_3COF was taken. Flow rates of N_2 and ClF_3 were

the same as in (10). The experiment was conducted at room temperature and, as in (10), it was again noticed that a vigorous exothermic reaction was proceeding.

ClF_3 was passed for one afternoon and the whole of the following day, during the next night, with ClF_3 cut off, a serious explosion occurred, necessitating the abandonment of the experiment. Up to that time 52 gm. of ClF_3 had been passed. No complete explanation has been suggested as yet for the explosion but two lines are possible

(1) The fortuitous entry of water into the system, from the reflux condenser for example.

(2) A chain reaction initiated during the night after a slow rise in temperature to some critical point.

(12) Experiment with CCl_3COCl .

Apparatus. The reaction vessel and reflux condenser were of metal in view of the great violence of the explosion recorded above. The reaction vessel was a cylindrical brass pot whose walls were $\frac{1}{4}$ " thick, the lid was of the screw-on type and the whole assembly was made gas tight by using a lead seal. The lid carried a brass lead-in tube and thermometer well, both reaching to within $\frac{1}{2}$ " of the bottom of the pot, in addition a wide vertical tube led to a water cooled reflux condenser of iron which in

turn led to the usual arrangement of pyrex traps cooled in solid CO_2 .

215 gm. of redistilled CCl_3COCl was taken.

N_2 flow rate 2 litres/hour.

ClF_3 flow rate 3 to 3.5 gm./hour for $8\frac{1}{2}$ hours.

7.5 to 8 gm./hour for $7\frac{1}{2}$ hours.

A total of 79 gm. of ClF_3 was passed during 16 hours.

Temperature (room temp.) was generally between 17.5° and 20°C .

The reaction was only slightly exothermic, a rise of 5°C . being noted during the early stages of the run. After the ClF_3 had been turned off a gentle stream of N_2 was allowed to blow through the apparatus for 24 hours to remove any dissolved, (and if possible any condensed,) ClF_3 .

196 gm. of yellow liquid was recovered from the reaction vessel. Distillation showed that no low boiling inert compounds were present in solution, about 10 gm. was obtained, coming over continuously from room temperature to 95°C . The remainder was unchanged CCl_3COCl . The 10 gm. obtained above was not fully examined but it evidently contained dissolved chlorine, and possibly

COCl_2 or CCl_3COF . Samples were completely soluble in alkali and gave qualitative tests for Cl^- and F^- ions.

The first cold trap contained 20-25 ml. of yellow-brown liquid. While this was being manipulated an escape of vapour occurred resulting in a violent explosion, afterwards attributed to the presence of ClF_3 vapour and liquid in contact with moist atmosphere.

A consideration of possible reaction mechanisms suggested that carbon monoxide might be a product of the reaction between CCl_3COOH and ClF_3 . Accordingly it was decided to run the usual apparatus in conjunction with an Orsat apparatus and perform gas analyses at regular intervals.

(13) Apparatus. Following the usual arrangement of reaction vessel, reflux condenser and traps cooled in solid CO_2 a device was arranged so that gases could either be vented to a suction hood, or diverted through a halogen scrubber (1 litre of 2N alkaline sulphite soln.) and so to the gas reservoirs and Orsat apparatus. The halogen scrubber was flanked by safety traps. (Figure 3).

Wt. of CCl_3COOH taken 72 gm.

N_2 flow rate was 2.7 to 3.0 litre/hour.

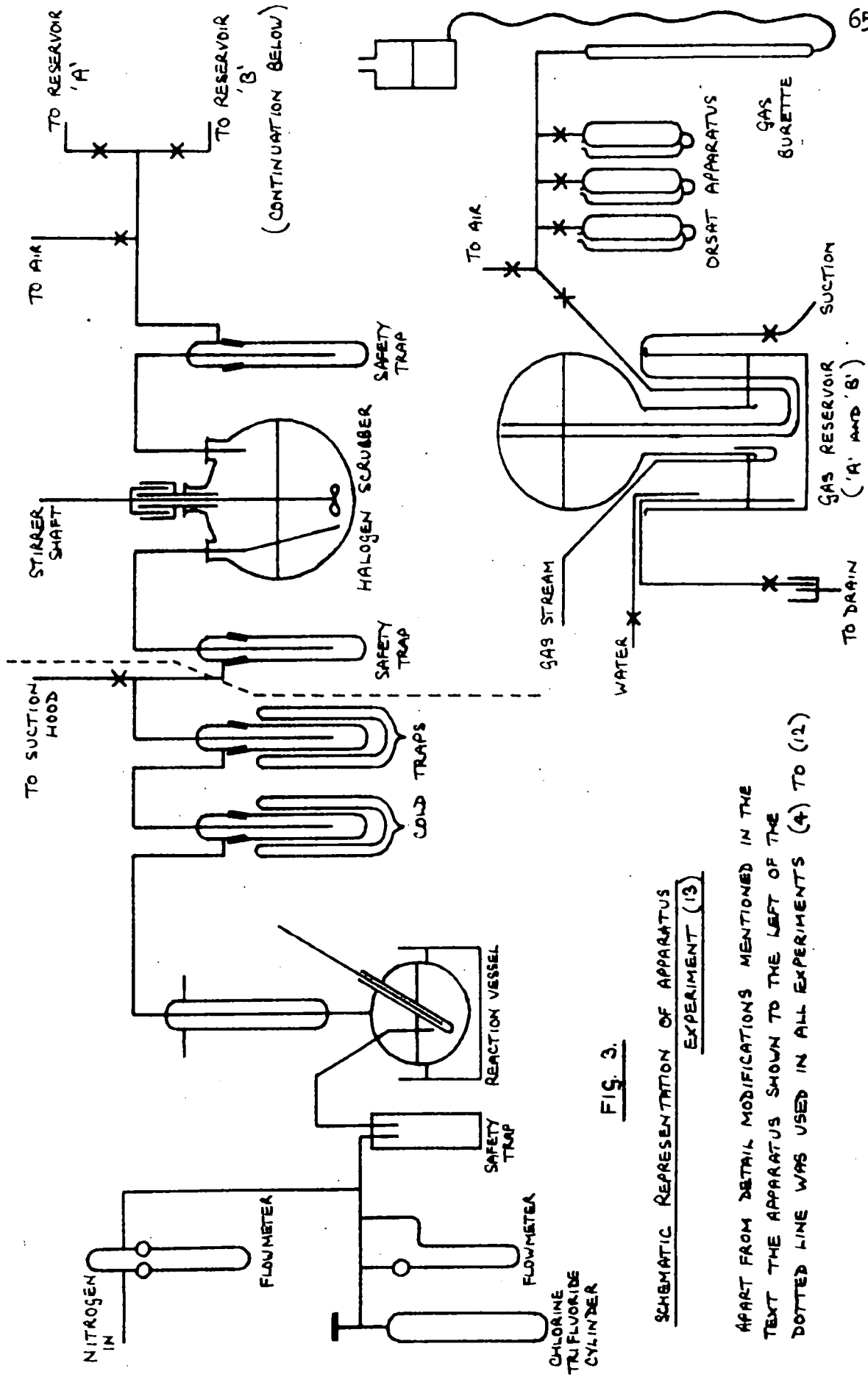

FIG. 3.

SCHEMATIC REPRESENTATION OF APPARATUS
EXPERIMENT (13)

APART FROM DETAIL MODIFICATIONS MENTIONED IN THE TEXT THE APPARATUS SHOWN TO THE LEFT OF THE DOTTED LINE WAS USED IN ALL EXPERIMENTS (4) TO (12)

ClF_3 flow rate was just over 4.0 gm./hour.

Temperature held at 70°C.

Altogether 25 gm. of ClF_3 was used during 6 hours running time. Gas analyses were conducted as follows.

1. After 1 hour the gases were collected at 3.0 litres/hour for 15 minutes. A 99.0 ml. sample contained no CO_2 , 17.5 ml. O_2 , and no CO.
2. After 2 hours the gases were collected at 3.0 litres/hour for 15 minutes. A 98.0 ml. sample contained no CO_2 , 16.8 ml. O_2 , and no CO.
3. (Second day). After $1\frac{1}{4}$ hours the gases were collected at 3.5 litres/hour for 7.5 minutes. A 98.5 ml. sample contained no CO_2 , 10.0 ml. O_2 and no CO.
4. (Second day). After $2\frac{1}{4}$ hours the alkaline sulphite solution in the scrubber was removed and a 1:3 benzene/ CCl_4 (v/v) mixture put in its place. Gases were collected through this for 15 mins. at 3.5 litres/hour. A 100.0 ml. sample contained 5.0 ml. CO_2 (or any acid gas), 10.5 ml. O_2 , and 1.0 ml. CO.

Blank determinations on the nitrogen from the cylinder showed the presence of 3.2% O_2 (a mean of 5 determinations).

Making the assumption that formation of gaseous products rises from zero in the first half hour and is subsequently constant, the total amounts of CO_2 , O_2 and CO formed were estimated.

Thus. Total oxygen = 1820 ml. (2.6 gm.:0.08 gm.mole)

Total carbon dioxide = 1150 ml. (2.2 gm.:0.05 gm.mole)

It is assumed here that the CO_2 measured after passage through benzene on the second day is in fact CO_2 and not a mixture of acid gases, and that about the same amount is produced on the first day, although it would not survive passage through an alkaline sulphite solution. Examination of other products: 40 gm. of solid residue was recovered from the reaction vessel. This was found to be unchanged CCl_3COCH . 18 ml. of yellow-green liquid was found in the first cold trap. This was allowed to warm slowly to room temperature over two days, during which time a slow stream of N_2 (1 litre/hour) was blown through the trap and into the scrubber containing 2N alkaline sulphite. By this means it was hoped to destroy any unused ClF_3 . A trap cooled in solid CO_2 was placed after the scrubber to collect any low boilers present. After two days, 15 gm. yellow liquid remained in the first trap at R.T. and 4 gm. had appeared in the trap following

the scrubber. 6 gm. had therefore been absorbed in the scrubbing solution. The yellow liquid was distilled, using a small claisen flask with fractionating side arm, and receivers at room temp. and at -78°C . The fractions obtained were:-

- (a) 1 ml. yellow liquid in the cold trap. Acyl halide smell.
- (b) 1 ml. colourless liquid boiling from R.T. to 60°C . Acyl halide smell.
- (c) 7 ml. colourless liquid boiling from 60°C . to 80°C . Smelling of CCl_4 but obviously containing some acyl halide.

The residue in the distilling flask started to decompose at 160°C ., turning brown and then black. There was a smell of camphor, suggesting that hexachloroethane might be present.

Fraction (c) was assumed to be almost entirely CCl_4 . It was washed with carbonate solution, dried over MgSO_4 , and redistilled giving 4 gm. B.Pt. $76-77^{\circ}\text{C}$. n_D^{20} 1.4600. The carbonate washings contained Cl^- ion but only a trace of F^- ion.

Fraction (b) was assumed to be (a) contaminated

with a little CCl_4 . (a) and (b) were combined and a sample added to a suspension of aniline in 2N alkali to see if an identifiable derivative could be formed in this way; a white oily solid was formed. The whole of (a) plus (b) was treated in the same way, the oily solid was washed with dil. HCl and the resulting granular precipitate was washed with water. After recrystallising twice from 30% alcohol and drying over P_2O_5 the solid had M.Pt. 242°C . This was very probably carbanilide formed from phosgene

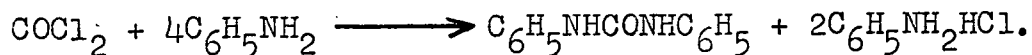

4 gm. of liquid remained in the trap following the scrubber. This was shown to consist of equal amounts of the low boiler (COCl_2 ?) and CCl_4 .

The next few experiments were designed to prove phosgene, to estimate it accurately, and to relate this estimate of COCl_2 with the amounts of oxygen and other gases produced. A copper furnace was built to remove O_2 from the nitrogen before passing into the reaction vessel.

(14) The arrangement of the apparatus was changed for this experiment. A two stage reaction vessel was constructed from two 100 ml. pyrex flasks, the second of these

carried a thermometer well and led to a "cut-off" device which directed the gas stream either through a halogen scrubber or through a benzene/ CCl_4 mixture. The scrubber destroyed all excess ClF_3 and also Cl_2 , COCl_2 , HF etc., any freons present continued via a large calcium chloride tube to a series of cold traps and, ultimately, to the Orsat apparatus. The benzene/ CCl_4 mixture also destroyed all excess ClF_3 but allowed Cl_2 and COCl_2 , (and HF of necessity) to proceed to a series of vessels containing pure benzene where it was hoped to dissolve them completely. The remaining gases were passed from the benzene dissolvers to the Orsat apparatus for analysis. The "cut-off" device was essentially two Y tubes of pyrex, one pair of arms was connected to the exit from the reaction vessel, the free arms led to the halogen scrubber and benzene/ CCl_4 mixture respectively. By means of levelling bottles, mercury could be pushed up the stems of the Y tubes to the junction of the arms where it prevented passage of gas. The mercury surface was protected by a layer of inert chlorofluorocarbon oil provided by I.C.I. General Chemicals Division. (Figure 4).

148 gm. of CCl_3COOH was taken.

N_2 flow rate 2.7 to 3 litres/hour.

Wt. of ClF_3 used 33 gm., 20 gm at 5.3 gm./hour and

13 gm. at 3.7 gm./hour.

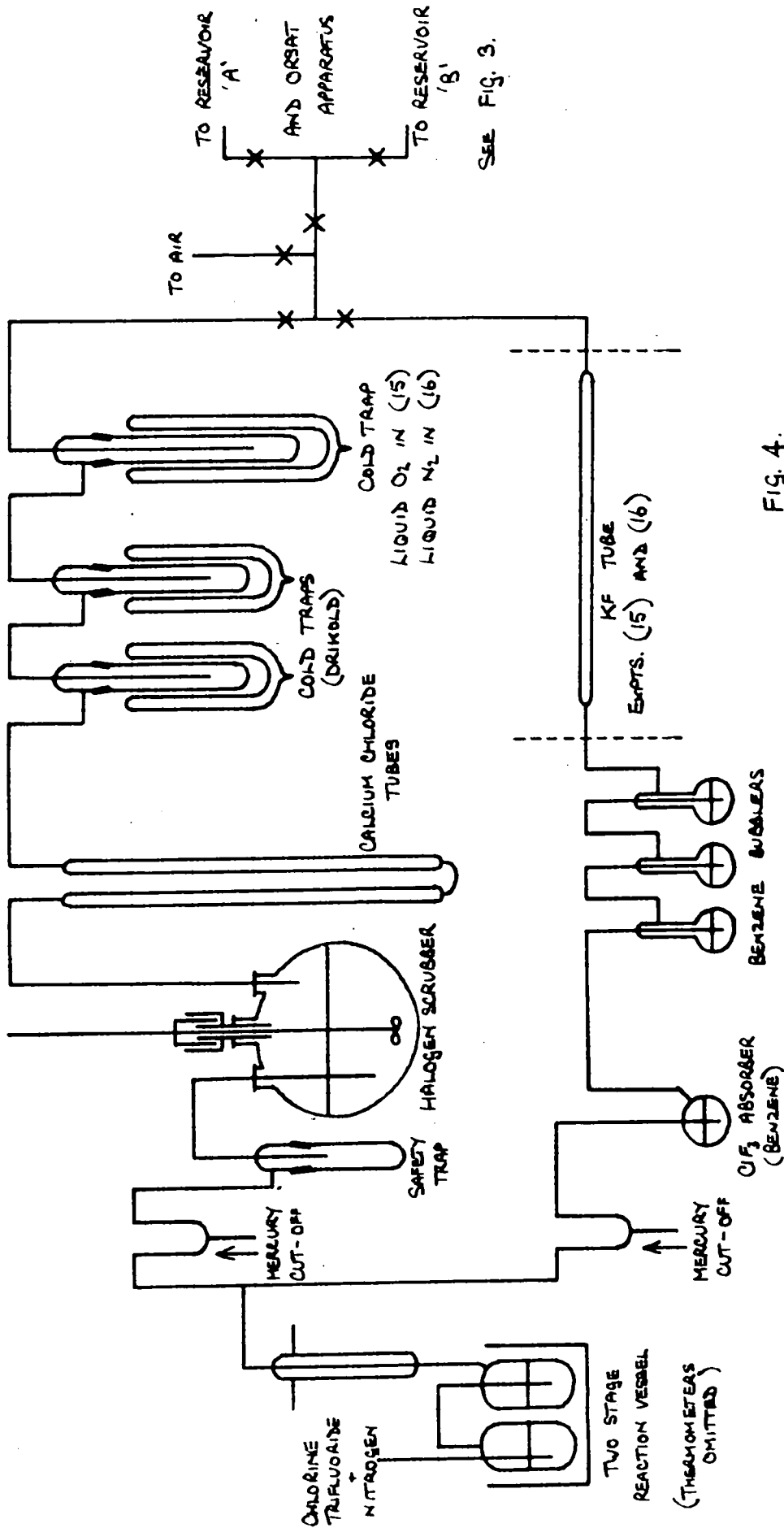

FIG. 4.

SCHMATIC REPRESENTATION OF APPARATUS
EXPERIMENTS (14) (15) AND (16)

The temperature of the oil bath was held at 95° - 100° C. On occasions the temperature registered in the reaction vessel was 105° C. Gas analyses were conducted as follows:

1. After $1\frac{1}{4}$ hours, gases from the halogen scrubber were collected at 4.0 litres/hour for 15 minutes. A 100 ml. sample contained 2.6 ml. O_2 and 5.5 ml. CO.
2. After $2\frac{1}{4}$ hours gases from the halogen scrubber were collected at 4.0 litres/hour for 10 minutes. A 98.0 ml. sample contained 2.8 ml. O_2 and 5.4 ml. CO.
3. After 3 hours gases from the benzene/ CCl_4 mixture were collected at 4.0 litres/hour for 10 minutes. A 99 ml. sample contained 4.5 ml. CO_2 , 2.8 ml. O_2 , and 14.6 ml. CO.
4. (Second day). After $1\frac{1}{2}$ hours gases from the halogen scrubber were collected at 4.0 litre/hour for 5 minutes. A 99 ml. sample contained 1.0 ml. O_2 and 10.8 ml. CO.
5. (Second day). After $1\frac{3}{4}$ hours gases from the benzene/ CCl_4 mixture were collected at 4.0 litres/hour for 10 minutes. A 99 ml. sample contained 6.4 ml. CO_2 , 2.2 ml. O_2 , and 13.4 ml. CO.

6. (Third day). After 1 hour gases from the halogen scrubber were collected at 40 litres/hour for 15 minutes. A 100 ml. sample contained 2.1 ml. O_2 and 5.1 ml. CO.

7. (Third day). After $1\frac{1}{2}$ hours gases from the benzene/ CCl_4 mixture were collected at 4.0 litres/hour for 15 minutes. A 100 ml. sample contained 11.7 ml. CO_2 , 10.0 ml. O_2 , and no CO.

Blank determinations (7) on nitrogen from the cylinder showed the presence of 0.5% O_2 . This nitrogen had been passed through a 30" copper furnace at a temperature above $400^\circ C.$, and then through two KOH towers to remove moisture.

Making the same assumptions as in (13) the total amounts of gaseous products formed were estimated.

Total oxygen = 480 ml. (0.69 gm., 0.022 gm. mole).

Total carbon monoxide = 1390 ml. (1.72 gm., 0.062 gm. mole.)

Total carbon dioxide = 1260 ml. (2.5 gm., 0.056 gm. mole.)

Examination of other products. 87 gm. of solid residue was recovered from the reaction vessel. Distillation showed that nothing other than CCl_3COOH was present.

7 gm. of product smelling of phosgene was recovered from the first trap, cooled in solid CO_2 . This was shown to contain 5 gm. of CCl_4 , the remainder being COCl_2 .

The benzene, containing dissolved products suspected to be COCl_2 and Cl_2 , was examined qualitatively and quantitatively for both of these products. According to Feigl ("Spot Tests", 1947 edition, p. 416) a sensitive test for phosgene in organic solution is the formation of a characteristic red violet to pink colour with phenylhydrazine cinnamate and copper sulphate. Phenylhydrazine cinnamate was prepared according to the directions in Ber., 24, 1106, (1891). Strips of filter paper were soaked in a 1% solution of copper sulphate and dried in an oven. The phenylhydrazine cinnamate powder was lightly rubbed into the paper and a drop of the following applied to each strip. (1) CCl_4 from the reagent shelf. (2) CHCl_3 from the reagent shelf, (3) A 12% solution of phosgene in toluene, (4) the benzene solution obtained in the experiment. (1) and (2) gave light violet colourations after about a minute. (3) and (4) gave immediate violet colourations. This is regarded as proof of the presence of phosgene.

The benzene solution was next boiled under reflux causing Cl_2 and COCl_2 to distill off together. These were collected in a trap cooled in solid CO_2 . About 2-3 ml. of green low boiling liquid was collected in this way: This was warmed very slowly to 0°C . and the gases passed through a small quantity of phenol in an attempt to form trichlorophenol from the chlorine assumed to be present. A heavy brown oil was formed but it could not be induced to crystallise. There remained about 1 ml. of colourless liquid in the cold trap at 0°C . This was passed over antimony trisulphide in a 2 ft. tube to remove any residual chlorine, and then into 250 ml. of a saturated aqueous solution of aniline (about 2% w./v.). Finally a stream of N_2 was passed through the system to clear all the COCl_2 . After a short time a copious white precipitate was thrown down. This was filtered off, the wt. of crude dry product being 1 gm. After two recrystallisations from 600 ml. of 30% alcohol and drying over P_2O_5 the solid had M.Pt. 243°C .

A sample of carbanilide was prepared according to the method described in Vogel: Practical Organic Chemistry p. 764. This was recrystallised twice from 30% alcohol, dried at 80°C . and had M.Pt. 243°C . The

mixed M.Pt. of this and the solid prepared above was 243°C . The mixed M.Pt. of the carbanilide sample and the solid prepared in (13) was also 243°C .

The benzene solution, even after refluxing for two hours, still contained some phosgene. An attempt was made to estimate this, using the method of Olsen, Ferguson, Sabetta and Schefflan, (Ind. Eng. Chem. Anal. Ed., 3, 189, 1931). In this paper a review is made of earlier analytical methods for phosgene and it is concluded that reaction with KI in acetone solution, liberation of iodine, and estimation of the iodine with standard thiosulphate is the most satisfactory. Other methods included absorption in alkali and estimation of Cl^- ion, and reaction with aniline in aqueous solution saturated with carbanilide, the precipitated carbanilide being dried and weighed. (Jaque, Chim et Ind, 19, 24, 1928. Fieldner, Katz, Kinney and Longfellow, J. Franklin Inst., 190, 543, 1920). The procedure adopted was as follows. A 25 ml. portion of the benzene solution was shaken for 1 minute with 2 gm. SbS_3 to remove any remaining chlorine, the suspension was filtered into 50 ml. of a 4% solution of KI in dry acetone. Iodine was liberated and was titrated in situ with thiosulphate solution, the end point could

be detected to the nearest drop without starch indicator.

An estimate was made of the total amount of phosgene formed in the reaction, bearing in mind the fact that the effluent gases had only been passed into the benzene bubblers for $1\frac{1}{2}$ hours out of a total 7 hours running time. About 2 gm. of phosgene had been determined by various means, indicating that 9 gm. must have been formed in the reaction.

Analysis of the contents of the halogen scrubber (see the section on the analysis of ClF_3 for the method) showed 26.0 gm. Cl^- ion and 9.2 gm. F^- ion present. Effluent gases were passed through the scrubber for $5\frac{1}{2}$ hours out of 7, so the figures become 33.0 gm. and 11.7 gm. respectively. Since only 33 gm. of ClF_3 was used much of the chlorine found in the scrubber must have come from the CCl_3 group in trichloroacetic acid.

(15). Experiment with CCl_3COCl .

Apparatus, used was the same as in (14) with three detail modifications. On the "benzene" side the first bubbler contained pure benzene and not a benzene/ CCl_4 mixture as previously. No difficulties were experienced with the absorption of unused ClF_3 during the experiment.

Also on the "benzene" side immediately preceding the gas reservoirs were placed two long tubes containing KF to absorb HF produced by the destruction of ClF_3 in benzene. On the "aqueous scrubber" side a third trap cooled in liquid oxygen was inserted in the train.

160 gm. of CCl_3COCl was taken.

N_2 flow rate about 2 litres/hour.

ClF_3 flow rate 3 gm./hour. 13 gm. of ClF_3
was used altogether.

Temperature 20-25°C. (room temperature).

Gas analyses were conducted as follows.

1. After $1\frac{1}{4}$ hours gases from the halogen scrubber were collected at 3.0 litres/hour for 10 minutes. A 98 ml. sample contained no CO_2 , 18.5 ml. of oxygen, and no CO.
2. After $2\frac{3}{4}$ hours gases from the halogen scrubber were collected at 3.0 litres/hour for 10 minutes. A 97 ml. sample contained 27.0 ml. of oxygen but no CO_2 or CO.
3. (Second day). After $1\frac{1}{4}$ hours gases from the benzene bubbler were collected at 3.0 litre/hour for 10 minutes. An 80 ml. sample contained 2.0 ml. O_2 but no CO_2 or CO.

Blank determinations on the nitrogen from the cylinder showed 0.5 ml. % of oxygen present. An estimate

was made of the total amount of oxygen formed.

Total oxygen = 1600 ml. (2.3 gm., 0.072 gm. mole.)

Examination of other products. 147 gm. of liquid were recovered from the two stage reaction flask. This was coloured yellow, fumed in air, and smelled of unchanged CCl_3COCl . Distillation gave pure CCl_3COCl and a very small amount of chlorine and possibly phosgene. The residue in the distillation flask was treated with water to hydrolyse residual CCl_3COCl . A white precipitate was thrown down which smelled of hexachloroethane. There was not sufficient material present to obtain a crystalline sample. Test tube experiments showed that hexachloroethane was extremely soluble in pure trichloroacetyl chloride.

About 2 gm. of CCl_4 contaminated with COCl_2 was recovered from the first drikold trap. A small amount of material, possibly CO_2 , was observed as a white frost on the walls of the liquid oxygen trap.

The liquid from the four benzene bubblers was combined and analysed for chlorine and phosgene. The total amount of chlorine and phosgene, as the thiosulphate equivalent, was found by adding an aliquot of the benzene solution directly to an excess of KI in

acetone and titrating the iodine. Phosgene was then determined separately after first destroying all the chlorine in an aliquot. Both SbS_3 and HgS should have been effective for this purpose, but it seemed from the titres obtained that SbS_3 was not removing chlorine completely from solution in benzene. The effectiveness of SbS_3 and HgS in removing chlorine from a mixture of chlorine and phosgene was tested under various conditions. Results showed that HgS (black) was equally effective whether it was used in suspension to absorb chlorine from solution in benzene or used dry to absorb chlorine from a gas stream. SbS_3 was effective when dry but failed when suspended in benzene solutions.

The amounts of phosgene and chlorine found were 0.5 gm. and 1.0 gm. respectively. Since the gas stream was only diverted through benzene for $\frac{1}{3}$ of the total running time the estimates of total amounts formed should be 1.5 gm. and 3.0 gm.

Analysis of the alkaline sulphite halogen scrubber showed 5.4 gm. Cl^- ion and 5.6 gm. F^- ion. Corrected estimates are therefore 8.1 gm. Cl^- and 8.4 gm. F^- ion. Evidently, all the fluorine from the 13 gm. ClF_3 originally used had reappeared in the scrubber.

(16) Experiment with CCl_3COCl at 65°C .

Apparatus, as in (15).

138 gm. of CCl_3COCl was taken.

N_2 flow rate 3 to 4 litres/hour.

ClF_3 flow rate 3 gm./hour for 9 hours.

6 gm./hour for 2 hours.

40 gm. ClF_3 were passed into the
reaction vessel altogether.

Temperature was held between 60° and 70°C .

Nine gas analyses were conducted at intervals during the eleven hours running time. No CO_2 or CO was found but consistent amounts of oxygen were found, the average being 6 ml. %. The estimate for the total amount of oxygen formed was 1900 ml. (2.7 gm., 0.085 gm. mole).

74 gm. of liquid were recovered from the reaction flask and shown to be almost entirely CCl_3COCl , Cl_2 and COCl_2 being the contaminants. The first trap, cooled in solid CO_2 , yielded about 1 gm. CCl_4 contaminated with COCl_2 . A thin film of solid was found in the nitrogen cooled trap but no conclusions could be formed as to its nature.

The benzene solution was analysed in the manner already described. Found, Cl_2 0.45 gm., COCl_2 0.84 gm. When corrected, allowing for the proportion of time during which the gas stream was actually passing through benzene the amounts estimated are, Cl_2 1.25 gm., COCl_2 2.4 gm.

As in (15), it was again found possible to precipitate a small amount of white solid, smelling of hexachloroethane, from a CCl_3COCl residue by hydrolysis and neutralisation. No detailed examination of the precipitate could be made however.

Analysis of the alkaline sulphite scrubbing solution showed 19.4 gm. Cl^- ion, and 11.6 gm. F^- ion. Corrected estimates are therefore 30.0 gm. Cl^- ion and 18.2 gm. F^- ion.

Observations during the last four experiments suggested that still further improvements could be made in experimental technique.

1. In (14), (15), and (16) it was noticed that phosgene was not completely absorbed in the benzene bubblers. In (16) it was actually possible to precipitate an appreciable quantity of carbanilide in an aqueous aniline solution

using samples of gas taken just before entering the Orsat apparatus.

2. The presence of phosgene in cold traps (14), (15), and (16) indicated that phosgene was not completely absorbed in the alkaline sulphite halogen scrubber.

Therefore, the absorption of a proportion of a gas sample in KOH solution in the first stage of the operation of the Orsat apparatus could not be taken to indicate that proportion of CO_2 with certainty. This was equally true of gas samples drawn from the "benzene" side. In fact it seemed doubtful whether CO_2 was ever formed at all.

3. Quantities of HF were formed when ClF_3 was destroyed by passage into benzene. The KF tubes were not entirely effective in absorbing this HF, which passed on and caused trouble in the gas reservoirs.

4. When pyrex apparatus was used SiF_4 was inevitably formed; on passage of the gas stream into alkaline sulphite H_2SiF_6 formed and ultimately silica was precipitated on the lead-in tube causing blockage. An all metal apparatus was indicated, at least wherever ClF_3 was likely to be present.

On the other hand it was noted that since equal amounts of oxygen were measured in samples drawn both from

the "benzene" and the "alkaline sulphite" sides then F_2O could not be a product of the reaction. F_2O and oxygen are both absorbed in $Na_2S_2O_4$ solution, but F_2O if present would also be absorbed in the alkaline sulphite scrubber.

The design of the last experiment included the following points.

1. Utilisation of ClF_3 in the reaction vessel was to be as complete as possible, the reaction vessel itself being of metal.
2. Unused ClF_3 was to be removed from the gas stream without removing any other products as well.
3. All products were to be condensed out together in an efficient series of cold traps, including nitrogen cooled traps.
4. The traps were to be warmed up one by one and phosgene and chlorine analysed by passing into KI/acetone solution. Inert compounds were to be condensed again after passing through the acetone and examined independently.
5. The gas stream from the condensed system was to pass through a KI solution to ensure that no halogens or acid

gases were present in samples analysed in the Orsat apparatus.

(17). Apparatus in accordance with points 1-5 above (Fig. 5). A compromise solution was reached concerning the absorption of ClF_3 . Aqueous alkaline absorbents would also stop Cl_2 and COCl_2 , and for this reason were ruled out. Large quantities of organic absorbent would hold back Cl_2 and COCl_2 in solution as well as inert products. Trials with mercury metal showed that ClF_3 did not react completely. Small amounts of benzene absorbed ClF_3 completely and it was thought that equilibrium between soluble products in the vapour stream and in solution would soon be reached bearing in mind the entrainment effect which always operated. However the entrainment effect caused benzene to appear in the first cold trap as an unwanted solid. Cumene was found to be a much better proposition. It has a much lower v.p. than benzene, (B.Pt. 152.3°C .) and is a liquid at drikold temperatures. Its reaction with ClF_3 has been studied (Ellis and Musgrave, *J. 1950, 3609*). After leaving the Cumene bubbler the gas stream passed through a large KF tube and thence into the condensing system. Here there were four traps cooled in solid CO_2 followed by two cooled in nitrogen. Each trap was provided with

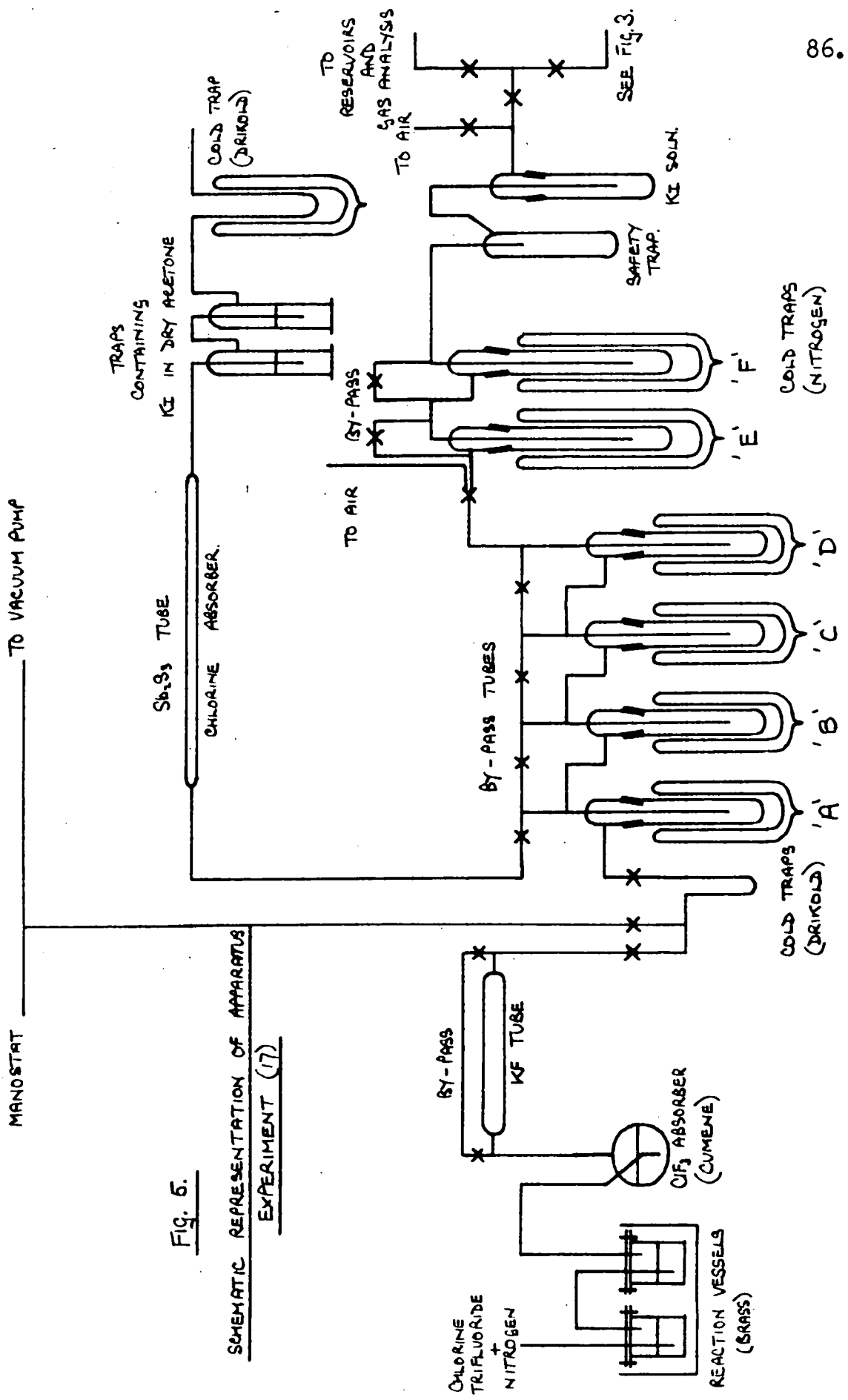

Fig. 6.

SCHEMATIC REPRESENTATION OF APPARATUS
EXPERIMENT (17)

a by-pass tube to be used in case of blockage. All stopcocks were lubricated with inert chlorofluorocarbon oil provided by I.C.I. General Chemicals Division. After leaving the condensing system gases passed through a safety trap and a KI bubbler and thence to the gas reservoirs and Orsat apparatus.

166 gm. of CCl_3COOH was taken.

N_2 flow rate between 2 and 2.5 litre/hour.

ClF_3 flow rate between 4 and 5 gm./hour.

31 gm. of ClF_3 were used altogether.

Temperature was held at 100°C . throughout.

The cumene bubbler gave no trouble during the course of the experiment. However it was observed that chlorine was absorbed rapidly, the initial (green) solution becoming decolourised inside half an hour, and remaining decolourised for the rest of the experiment. Absorption of HF seemed to be complete. The KI bubbler placed after the condensation section was only a pale yellow colour at the end of the experiment showing that halogens and phosgene were being completely held. Gas analyses were conducted at intervals but no CO_2 , O_2 , or CO was found at any time.

Examination of products in the cold traps. (A, B, C,

and D, cooled in solid CO_2 , E, and F cooled in liquid N_2 , see Fig. 5). 'A' contained approx. 30 ml. of clear pale yellow-green liquid, probably containing cumene (B. $153^\circ\text{C}.$) CCl_4 (B. $76^\circ\text{C}.$) COCl_2 (B. $9^\circ\text{C}.$) CCl_3F (B. $24^\circ\text{C}.$) The colour would be due to small amounts of Cl_2 (B. $-33^\circ\text{C}.$) and it was therefore possible that small amounts of COClF (B. $-42^\circ\text{C}.$) might be present. 'B' contained about 0.5 ml. liquid as above. 'C' and 'D' were empty. 'E' contained solid material, the amount of which could not be determined by observation because it was distributed on the walls of the trap. The solid was in bands coloured green, white, and buff. Cumene and CCl_4 would have been absent, but Cl_2 , COCl_2 , COClF , COF_2 and CO_2 could have been present as solids, together with CCl_2F_2 , CClF_3 , and CF_4 . 'F' contained about 10 ml. of colourless liquid. The possibilities here were limited to oxygen or CF_4 (B. $-127.7^\circ\text{C}.$ M $-145^\circ\text{C}.$). Oxygen is the most probable since none was found in the gas analyses.

Trap 'A' was warmed to $40^\circ\text{C}.$ and volatile contents distilled into 'B'. The residue, about 10-15 ml. of colourless liquid was distilled giving 1 ml. of pure CCl_4 boiling at $76-77^\circ\text{C}.$ The rest boiled continuously from $40^\circ\text{C}.$ to $70^\circ\text{C}.$ This was contaminated with COCl_2 , but subsequent examination after destruction of COCl_2

with carbonate solution suggested that a small amount of CCl_3F was also present. As yet there is no definite proof of this however. The colourless residue was cumene.

Trap B, containing volatile components from A was warmed to 0°C . About half the volume, 5-10 ml., distilled and was collected in E, cooled in nitrogen. The rest, a clear yellow-green liquid smelling of Cl_2 and COCl_2 , amounted to 13 gm. Subsequent analysis showed that it consisted of equal weights of Cl_2 and COCl_2 .

The colourless liquid previously noted in F, disappeared overnight, leaving a small amount of frost on the walls of the trap. It was noted that when the trap was warmed slightly the frost disappeared without forming any liquid, suggesting the presence of CO_2 .

The solid mixture in E was warmed gently by substituting a drikold dewar for the nitrogen dewar. Traps D and C were cooled in nitrogen and the mixture was allowed to distill. Distillation was interrupted once or twice because solid collected in the inlet tubes (CO_2). When equilibrium had been reached the traps were isolated from each other and their contents analysed

separately for phosgene or COClF , COF_2 . Any chlorine present was destroyed by passing the vapour over SbS_5 , the chlorine-free mixture was passed into a solution of KI in dry acetone. Iodine was liberated and insoluble KCl and KF were thrown down. This was filtered off, washed with dry acetone, dissolved in water and made up to standard volume. The solutions were then analysed and the amounts of F^- ion and Cl^- ion found. The filtrate of iodine in acetone was made up to standard volume and the iodine determined with thiosulphate.

The results of these analyses contained inconsistencies. The amounts of Cl^- ion found indicate in each case about twice the amount of COCl_2 that would be expected from the iodine analysis. On the other hand appreciable amounts of F^- ion were found.

From C and D		From E	
(Substances B. from -190 to $-78^\circ\text{C}.$)		(Substances B. from -78 to $0^\circ\text{C}.$)	
I_2	0.358 gm.	I_2	1.86 gm.
Cl^-	0.201 gm.	Cl^-	1.145 gm.
F^-	0.045 gm.	F^-	0.017 gm.
Ratio Cl:F	2.4:1	Ratio Cl:F	36:1

The presence of fluorine in such relatively large quantities is strong evidence for the presence of COF_2 or COClF in traps C and D.

The first brass reaction vessel was found to be completely empty, save for a film of white solid at the bottom smelling of C_2Cl_6 . About 1 gm. of a crystalline solid had sublimed into the brass tube leading to the second reaction vessel. This contained 87 gm. of a brownish crystalline solid and 2-3 ml. of a brownish liquid, the whole smelling strongly of C_2Cl_6 and fuming slightly. When this had been neutralised with sodium carbonate there remained an insoluble solid, which was filtered off and dissolved in the smallest possible quantity of methyl alcohol. The solid was reprecipitated with water but could not be filtered because the particles were extremely finely divided, it was almost certainly C_2Cl_6 . The sublimate was removed from the brass tube and dissolved in a small quantity of methyl alcohol. It was reprecipitated with water and filtered off. After drying over P_2O_5 there remained about 1 gm. of white solid.

Approximate estimates were made of the quantities of each product formed in the reaction. COCl_2 : 10 gm.,

Cl_2 : 10 gm., CCl_4 : 2 gm., C_2Cl_6 : 2 gm., CCl_3F , COF_2 ,
 COClF , O_2 , CO_2 , may have been formed but no quantitative
information was obtained.

II. THE ANALYSIS OF CHLORINE TRIFLUORIDE

THE ANALYSIS OF CHLORINE TRIFLUORIDE

The work described in this section was undertaken as a check on the purity of the chlorine trifluoride.

It was considered that chlorine trifluoride could be analysed by methods analogous to those used for elementary fluorine. There are two possible methods for such analyses.

A. Fluorine, which has had HF removed previously, is passed through a tube containing an alkali metal chloride or bromide. Reaction occurs giving alkali metal fluoride and free chlorine or bromine. The fluoride is dissolved and is determined by titration. Chlorine or bromine as the case may be, passes on and is quantitatively absorbed in alkali. The resulting halide solution is determined after reduction of hypohalite with sodium sulphite.

Turnbull et al., (Ind. Eng. Chem., 39, 286, 1947) recommend NaCl in a glass tube at room temperature. Other workers prefer to heat the tube containing halide. Elving et al. (Fluorine Chemistry, Ed. Simons Vol. 2, pp. 55-56) quote the use of NaCl at 200°C, NaBr at

230°-250°C, and NaBr at 150°C. Nash (Anal. Chem. 21, 980, 1949) showed that gases containing more than 5% of fluorine cause bromides to become strongly heated but not sufficiently so to ensure complete reaction. Stoichiometric reaction does not occur until NaBr is held at 100°-125°C and for routine analyses the optimum temperature was found to be 150°C.

B. Fluorine may be passed into alkali containing a reducing agent where it is quantitatively absorbed. After destruction of excess reducing agent the fluoride ion is titrated directly.

Downing, (Preparation, Properties and Technology of Fluorine and Organic Fluorine Compounds, Chap. 3, p. 75) notes that although absorption of fluorine in alkali leads to the formation of 16-24% F₂O, no F₂O is found if the absorption takes place in the presence of sodium sulphite. Kimball and Tufts, (U.S.A.E.C. MDDC-195, 1946) absorbed F₂O in alkaline arsenite solution.

EXPERIMENTALMethod A.

Three trials were performed, two at room temperature and one with the tube containing NaCl held between 120°C and 140°C. In all cases ClF₃ diluted with an equal amount by volume of N₂ was passed over a known weight of pure dry sodium chloride. The gas stream emerging from the tube was passed into two vessels containing 50% w.v. KOH and finally through a solution of KI containing sodium dihydrogen phosphate buffer, both $\frac{N}{4}$, to detect any halogen not absorbed in the alkali. After ClF₃ had been disconnected the system was flushed out with N₂. The sodium chloride tube, now containing sodium fluoride, was reweighed and the amount of fluoride present calculated from the loss in weight. The contents of the tube were then dissolved in water and fluoride and chloride ions determined separately, the former by the method of Rowley and Churchill, (Ind. Eng. Chem., Anal., 9, 551-552, 1937) and the latter by the method of Kolthoff, Lauer and Sunde, (J.A.C.S., 51, 3273, 1929). Aliquots of the alkaline sulphite solution were boiled with HNO₃ to destroy excess sulphite, following which chloride and fluoride were determined by the above methods.

The iodine liberated in the $\text{KI}/\text{NaH}_2\text{PO}_4$ solution was determined with standard thiosulphate.

The results obtained from all three trials showed that there were serious defects in the method.

(a). The amount of chloride found in the alkaline scrubber was greater by factors up to $\times 3$ than the total amount of fluoride found.

(b). Iodine was liberated on all three occasions in the KI solution.

(c). The glass tube containing sodium chloride was considerably etched and insoluble silica was precipitated in the alkaline scrubber.

(a). and (b). taken together indicate that even at the higher temperature the reaction between ClF_3 and NaCl is not complete and that some ClF_3 travels as far as the alkaline scrubber, where it forms F^- and F_2O . F^- formed cannot be correctly calculated from the loss in weight of the tube.

(c). indicates the possibility that determination of fluoride in the scrubber might be incomplete because of absorption of F^- on the silica.

Method B.

A number of trials of this method showed that loss of fluorine as F_2O was negligible so long as excess sodium sulphite was present in the alkaline scrubber. (Usually iodine was liberated equivalent to about 0.001 gm. fluorine during the passage of 5 gm. ClF_3 i.e. an error of 1 part in 3000).

This method was standardised as follows.

ClF_3 at 1.5 gm/hour and N_2 at 1 litre/hour were passed for $1\frac{1}{2}$ hours into a 5% solution of NaOH containing 5% of Na_2SO_3 . Three scrubbers were used, each containing about 30 ml. of solution. The lead-in to the first scrubber was of stainless steel. The usual KI/NaH_2PO_4 $\frac{N}{4}$ solution was retained at the end of the train as a check on the complete absorption of halogens. After 1.5 hours ClF_3 was turned off, the system was flushed with N_2 , and the contents of the scrubbers were washed out, combined, and made up to 500 ml.

For chlorine analysis 25 ml. was taken, boiled with 5 ml. conc. HNO_3 , cooled, neutralised to phenolphthalein with alkali, and titrated with standard silver nitrate using dichlorofluorescein as indicator.

For fluoride analysis, 50 ml. of the solution were diluted to 250 ml. 25 ml. samples were taken and boiled for 5 minutes with 5 ml. 2N HNO_3 , then cooled. Alizarin indicator (8 drops) was added and the solution was neutralised with alkali to a pink colour, returning to the yellow colour with more dilute acid (0.2N HCl). Buffer solution (1 ml.) was added (9.338 gm. CH_2ClCOOH , 2.0 gm. NaOH in 100 ml. water) and the solution was titrated with standard 0.02N thorium nitrate until precipitated ThF_4 became visible (about $\frac{4}{5}$ of the total titre). This was filtered off, washed, a further 8 drops of indicator added and the titration continued to the end point (yellow green to buff-pink).

Results.

	Cl	F	Ratio Cl:F
1.	0.53 gm.	0.65 gm.	1:2.30
2.	0.71 gm.	0.82 gm.	1:2.16
3.	0.44 gm.	0.632 gm.	1:2.68
4.	0.582 gm.	0.790 gm.	1:2.56

Numbers 1. and 2. were experiments in which the lead-in tube to the first scrubber was of glass, in numbers 3. and 4. this glass tube was replaced by one of stainless steel. The improvement due to elimination of silica

from the scrubbing solutions is of the order of 15%. Even under these conditions the experiment is not wholly satisfactory since a small amount of ferric hydroxide is formed, which may hold up fluoride in the same way as the silica.

Two further series of tests were carried out to estimate the effect on the recovery of fluoride of boiling the scrubbing solution during destruction of excess sulphite with nitric acid. In the first, aliquots of standard sodium fluoride solution were titrated with thorium nitrate a) at once b) after boiling for five minutes with 5 ml. of 2N HNO_3 . The mean of titrations a) was found to be 7.0% greater than that of titrations b).

Subsequently mixtures of 25 ml. of diluted scrubbing solution and 25 ml. of standard sodium fluoride solution were titrated with $\text{Th}(\text{NO}_3)_4$ solution, after boiling in the usual way, and the results were compared with the sum of the separate titrations on 25 ml. diluted scrubbing solution and 25 ml. standard sodium fluoride solution.

Total titre	Separate	titres	% difference
40.30 ml.	24.0 ml.	18.20 ml.	4.7
34.00 ml.	17.6 ml.	18.20 ml.	5.2
38.10 ml.	21.9 ml.	18.20 ml.	5.3

These fluoride losses are in line with results quoted on pp. 54 and 73 of " Fluorine Chemistry " (Ed. Simons) Vol. 2. A number of authors noted losses from zero to twenty percent under varying conditions.

Making the requisite correction of 6% to the mean ratio of 1:2.62 found previously the final result is found to be 1:2.80 which corresponds to chlorine trifluoride of 96% purity.

The method is susceptible to improvement in three ways:

1. By ensuring complete absorption of ClF_3 in the alkaline sulphite.
2. By ensuring that all fluoride in the scrubbing solution is titrated, and that none is lost by boiling, or by absorption on any precipitates.
3. By improving the method of fluoride analysis.

Although the overall accuracy of the Rowley and



Churchill method is only $\pm 1\%$ it was chosen in preference to later and more accurate methods because of its great simplicity. Titrations can be carried out over a wide range of fluoride concentrations and the pH is easily controlled by the addition of a buffer. Most of the later methods of analysis are comparative methods which would have been inapplicable in this work.

III. PRELIMINARY INVESTIGATIONS INTO THE POSSIBILITY
OF ANALYSIS OF FLUORINE IN ORGANIC COMPOUNDS
BY AN AMPEROMETRIC METHOD

PRELIMINARY INVESTIGATIONS INTO THE POSSIBILITY
OF ANALYSIS OF FLUORINE IN ORGANIC COMPOUNDS
BY AN AMPEROMETRIC METHOD

INTRODUCTION

It is necessary to determine the amount of fluorine in an organic compound with an error not exceeding 0.1%. Most methods start with samples of 100 mgm., this is fused with an excess of sodium at temperatures above 400°C. for several hours, by which time fluorine is present as sodium fluoride. Excess sodium remaining after the fusion is destroyed and the remains are made up to some suitable standard volume. 100 mgm. of a compound containing 38% F would give 84 mgm. NaF after fusion, which when dissolved up in 100 ml. of solution gives 0.02 N fluoride.

The fluoride solution has generally been titrated with thorium nitrate solution in the presence of sodium alizarin sulphonate as indicator. It is agreed that correct determination of the end point (yellow - buff - pink when fluoride is buffered with monochloroacetic acid) presents difficulties, and many

modifications have been suggested in order to overcome this. (Elving and Liggett, Ind. Eng. Chem. Anal. Ed., 1942, 14, 449; Belcher, Caldas, Clark, and Macdonald, Mikrochem Acta 1953, 283). Whilst control of pH, fluoride concentration, conditions of the titration, and concentrations of other ions present undoubtedly assists detection of the end point the net result is a very tedious analytical routine. Moreover, at the time when this investigation was undertaken, (December 1953) thorium nitrate was not obtainable in "AnalaR" grade purity and samples had to be standardised against standard sodium fluoride, the latter obtained by exactly neutralising 40% HF with standard sodium hydroxide. Further it is known that the reaction between thorium nitrate and sodium chloride in solution is not stoichiometric, gravimetric and titrimetric values for the equivalent differ by 1.5%, the former being the larger.

During the last fifteen years a number of authors have described polarographic and amperometric methods for determining fluoride ion in solution but in no case have the methods been applied to the estimation of fluoride ion in the solution obtained after fusion of an organic compound with sodium. It was decided to

examine an amperometric method and see whether it could be applied successfully to the determination of fluorine in such solutions.

In amperometry the diffusion current in a cell containing M^+ ions is measured, the applied P.D. being constant and greater than the half-wave potential of the ions. The observed current is plotted against the amount added of some reagent which forms an insoluble compound or a complex with M^+ ; as more and more of the ions are removed from solution the measured diffusion current falls (it is proportional to $[M^+]$) and it is a minimum at the end point. Three shapes are possible for the graph of diffusion current vs. volume of reagent added (Figures 1, 2, and 3.) The diffusion current has to be corrected for dilution which increases as each increment of reagent is added.

Willard and Dean (Analyt. Chem. 22, 1264, 1950), investigated the polarographic determination of aluminium by electroreduction of an aluminium-o-hydroxy azo dye complex at a potential of -0.5 volts vs. a saturated calomel electrode. The current - voltage curve for the free dye showed a single wave at about

-0.2 volts vs. S.C.E. (Figure 4). The height of the wave was proportional to the concentration of the free dye. In the presence of small amounts of Al^{+++} ions (the dye being present in excess) the wave was stepped, part of it being displaced 0.2 volts more negative. The height of the second step was proportional to the concentration of aluminium (Figure 4). The method was claimed to be sensitive to 0.005 gm. Al in 50 ml. of solution and to have an accuracy of $\pm 3\%$. The effect of several ions on the determination was noted and in particular it was mentioned that fluoride formed a more stable complex with aluminium than did the dye.

MacNulty, Reynolds, and Terry (Nature 169, 888, 1952) examined the statement by Willard and Dean that fluoride interfered with the determination of aluminium, and found that the interference was quantitative. This was made the basis of a polarographic method for determining fluoride. A known excess of aluminium, and sufficient dye in aqueous solution to complex all the aluminium, were added to the fluoride solution. Al-fluoride and Al-dye complexes were formed. The solution was polarographed and the height of the second wave, proportional to

the amount of aluminium complexed with the dye, was measured. Subtraction gave the amount of Al present as AlF_6^{---} and hence the amount of fluoride present.

Castor and Saylor (Analyt. Chem. 24, 1369, 1952) described an amperometric method for determining fluoride based on the observations of Willard and Dean. Aluminium-dye complex was added to the fluoride solution and decomposed with the formation of an aluminium fluoride complex and the release of free dye. The diffusion current increased linearly with the amount of free dye released by formation of AlF_6^{---} until the equivalence point was reached. After this point no more free dye was released and the diffusion current remained constant. (Figure 5) Results accurate to $\pm 1\%$ using solutions containing between 2 and 8 mgm. F^- ion per 100 ml. were claimed.

The reverse determination of aluminium with fluoride ion using Fe^{+++} ion as indicator ion has been described by Ringbom and Wilkman. (Acta Chimica Scandinavica, 3, 22, 1949) Both iron and aluminium form complexes with F^- of the type MF_6^{---} of which the aluminium complex is the more stable. Thus if

a fluoride solution is added to a solution containing both Al^{+++} and Fe^{+++} ions the diffusion current due to Fe^{+++} is observed only after all the Al^{+++} has reacted. The way in which the diffusion current changes is shown in Figure 6. Best results were said to have been obtained in the presence of 50% alcohol in solutions saturated with NaCl. Alcohol inhibited reaction of Fe^{+++} until all Al^{+++} had reacted, and NaCl facilitated formation of Na_3AlF_6 . Optimum conditions included a pH of 2.5 to 3.5. The maximum error quoted was 0.5%.

Langer (Ind. Eng. Chem. Anal. Ed. 12, 511, 1940) described the amperometric titration of sodium fluoride solutions with thorium nitrate solution at a potential of -1.7 volts vs. S.C.E. The diffusion current remained constant while F^- ions were being removed from solution as ThF_4 . As soon as excess Th^{++++} ion was present the diffusion current rose, being proportional to $[\text{Th}^{++++}]$. (Figure 7) Between 0.2 and 10 mgm. of NaF in 50 ml. samples were analysed. The average error was 0.8%.

Although the error quoted was greater than one would have wished, it was sufficiently small to merit a trial of the method with fusion solutions.

APPARATUS AND EXPERIMENTAL PROCEDURE

The amperometric titration apparatus was essentially the same as described by Kolthoff and Langer, "Polarography" p. 459-61. (Also Kolthoff and Langer, J.A.C.S., 62, 211, 1940) (Figure 8).

The electrical arrangement was a modified form of the circuit described by Kolthoff and Pan (J.A.C.S., 61, 3402, 1939) (Figure 9). With S_1 and S_2 to the right the potential required to cause electroreduction of Th^{++++} ions was applied between the dropping mercury cathode and a saturated calomel electrode, i.e. knowing the accumulator voltage and the length of the potentiometer wire the position of the contact on the potentiometer was calculated and the contact set accordingly. The resistances forming the potential divider were then adjusted so that the Cambridge Spot Galvanometer showed no deflection when contact was made. The two switches were then thrown over and the diffusion current between the dropping mercury cathode and the mercury pool anode was measured by determining the potential drop across the resistance box. Knowing the values of the resistance and of the potential drop across it the diffusion current was calculated.

In order to avoid individual oscillations of the galvanometer needle with each drop falling from the mercury cathode the galvanometer was used with a 1000 ohm resistance in series and a 4000 mfd. condenser in parallel across both galvanometer and resistance. This arrangement effectively damped out individual oscillations (Figure 10).

The potentiometer was of the barrel type, and during measurements only the extreme end of the barrel was used. Occasionally a 3500 ohm resistance was used in series with the potentiometer but no increase in accuracy resulted since the sensitivity was decreased by a factor of 10. A potentiometer box with built-in galvanometer replaced the barrel and Cambridge Spot galvanometer in later determinations. This arrangement was more convenient to work with and was only a little less sensitive, when in use it was placed in series with the 4000 mfd. condenser to damp out galvanometer oscillations (Figure 11).

The experimental procedure resolved itself into four operations.

1. The potential of -1.7 volts vs. S.C.E. required for the electroreduction of thorium ions was set in the manner described above.

2. The fluoride solution, whose pH had been adjusted to 8.0 with dilute HCl, was pipetted into the cell and any dissolved oxygen was removed by blowing nitrogen through for 10 minutes. The apparatus was arranged so that the oxygen could be removed simultaneously from solution in the cell and from the reagent reservoir.

3. The burette was filled with de-oxygenated thorium nitrate solution and the first increment was added to the contents of the cell. This amount was usually 0.5 ml. or 1.0 ml. Nitrogen was then blown through the cell to stir the contents and remove residual oxygen.

4. The diffusion current flowing in the cell was then determined in the manner described above. When this had been done the second increment of thorium nitrate was added and the diffusion current again determined, etc. etc. A complete determination took about half an hour.

The most evident cause of trouble was the behaviour of the dropping mercury cathode. The drop rate was greater in electrolyte solutions than in distilled water, (an effect frequently noted in the literature; adjustment and calibration of the capillary

was always done in aqueous KCl.) greater when current was passing than on other occasions, and greater after the capillary had aged. The life of a capillary was about one week. Adjustment of capillaries was by removing fractions of an inch from their length (coarse), or by raising or lowering the mercury reservoir (fine). The problem of keeping the head of mercury constant hardly arose because of the large size of the reservoir compared with the small amounts of mercury used in replicate determinations. In all replicated experiments the drop rate was kept constant at some value between 3 and 6 sec. per drop. All mercury used in the apparatus was washed with nitric acid and distilled under vacuum.

RESULTS

These are set out in tables 1. and 2. and in the accompanying graphs.

Table 1. shows results obtained with solutions of sodium fluoride (Very Pure Grade) containing potassium chloride as supporting electrolyte. With the exception of Numbers 1a, 1b and 2, the pH was adjusted to 8.0. The exceptions listed had pH 4.6 and were buffered with sodium acetate.

Table 2. shows results obtained with fusion solutions. The pH of these solutions was adjusted to 8.0 with dilute HCl but no additional supporting electrolyte was added. Determinations marked * were those in which excess sodium remained after fusion was destroyed without the use of alcohol. The determination marked ** was one in which sodium was destroyed without alcohol, but in which 10 ml. (20%) of alcohol was subsequently added to the solution in the titration cell. All determinations listed in Table 2. were checked by titration by the method of Belcher, Caldas, Clark, and MacDonald (loc. cit.) and with the exception of 2b, the results agreed with the figure calculated from the weight of organic compound taken. This showed that the fusion with sodium had been complete. In the case of 2b. 0.0032 gm. NaF was found, (0.0030 gm. found amperometrically) suggesting that the bomb had blown during fusion. Determinations 8b. and 8c. are of interest, assuming that sodium sulphide is formed during fusion, and that reaction between sodium sulphide and thorium nitrate is quantitative under the conditions of the titration, then making allowance for the amount of $\text{Th}(\text{NO}_3)_4$ lost as insoluble ThS_2 the result for sodium fluoride is only 6% low.

DISCUSSION OF RESULTS AND CONCLUSIONS

Seventeen out of the nineteen end points determined graphically were unambiguous, and the remaining two curves can be interpreted without difficulty to give end points which are in good agreement with the rest. Almost all the curves show an initial downward sloping portion, which implies that the first increments of thorium nitrate are removing from solution some electro-reducible ion. Accordingly therefore a correction should be made for $\text{Th}(\text{NO}_3)_4$ lost in this way, but any such correction when applied leaves the results worse than before.

One of the most interesting points which arise out of Langer's work is the effect of alcohol on the end point of the titration. In normal titrations with thorium nitrate and sodium fluoride the presence of alcohol is advantageous because it reduces the solubility of ThF_4 . In amperometric titrations however the presence of alcohol causes a shift of the end point to higher values. In 80% alcohol solution the titre is 35% greater than theory. Determinations 4a, 4b, 5a, 5b may well illustrate this point, all the end points are between 25 and 36% high and all the titrations took

place in the presence of alcohol. On the other hand, when the destruction of sodium was performed without the use of alcohol no end points were obtained except in 8b. and 8 c., and an explanation for these results has already been suggested.

Discrepant results may be ascribed to the effect of a variable drop rate from the dropping mercury cathode, and the occasional use of the barrel potentiometer with the contact almost at the end stop. Using an improved electrical apparatus, possibly incorporating a valve voltmeter to give accurate relative P.D.'s and a capillary which could be relied upon to give a constant drop rate over about a week, good results could be obtained from determinations of fluoride solutions made from pure NaF, and fluoride solutions from sodium fusions. It seems doubtful however if the accuracy of the results would justify the use of an amperometric method as a standard method of analysis. In addition recent work (Banks, Cuthbertson and Musgrave, *Anal. Chim. Acta*, to be published shortly), has shown that fluoride from fusion solutions may be conveniently and accurately analysed by means of an ion exchange method.

TABLE 1.

No.	Volume	Wt. KCl	Strength of Th(NO ₃) ₄	Volume of Th(NO ₃) ₄	NaF found	NaF present	Error
1a	100ml.	0.30gm.	3.7860gm./l.	8.20ml.	0.0094gm.	0.0076gm.	20% +
1b	100ml.	0.30gm.	3.7860gm./l.	8.10ml.	0.0093gm.	0.0076gm.	20% +
2	100ml.	0.075gm.	3.7860gm./l.	1.45ml.	0.0016gm.	0.0019gm.	15% -
3a	75ml.	5.58gm.	2.699 gm./l.	4.48ml.	0.0036gm.	0.0040gm.	10% -
3b	75ml.	5.58gm.	2.699 gm./l.	5.27ml.	0.0043gm.	0.0040gm.	8% +
4a	100ml.	7.45gm.	2.699 gm./l.	6.23 - 6.57ml.	0.0053gm.	0.0054gm.	2% -
4b	100ml.	7.45gm.	2.699 gm./l.	6.50 - 6.75ml.	0.0055gm.	0.0054gm.	2% +
4c	100ml.	7.45gm.	2.699 gm./l.	6.02ml.	0.0049gm.	0.0054gm.	7.5% -
4d	100ml.	7.45gm.	2.699 gm./l.	6.07ml.	0.0050gm.	0.0054gm.	7.5% -
5a	100ml.	7.45gm.	13.346 gm./l.	5.45ml.	0.022 gm.	0.0267 gm.	17% -
5b	100ml.	7.45gm.	13.346 gm./l.	5.95ml.	0.024 gm.	0.0267 gm.	9.5% -

TABLE 2

No.	Compound	Wt. taken (g.)	Volume (ml.)	Strength (g/l)	Th(NO ₃) ₄ Volume (ml.)	NaF found (g.)	NaF present (g.)	Error %
1	m-fluorobenzoic acid	0.07204	50	2.699	No end point obtained	0.0108		-
2a	"	0.06896	"	"	"	0.00517		-
2b	"	"	"	"	3.65	0.00304	"	41
2c	"	"	"	"	No end point obtained	"	"	-
3a	"	0.10722	100	"	7.15	0.0059	0.00643	9
3b	"	"	"	"	No end point obtained	"	"	-
4a	"	"	50	"	9.92	0.00815	"	26.7
4b	"	"	"	13.346	2.05	0.00852	"	32.5
5a	"	0.07784	75	2.699	10.73	0.0088	0.0070	25.7
5b	"	"	"	13.346	2.36	0.0095	"	36.5
6a	"	0.05617	50	2.699	No end point obtained*	0.00337		-
6b	"	"	60	"	"	**	"	-
7a	"	0.06517	50	"	"	**	0.00391	-
7b	"	"	"	13.346	"	**	"	-
8a	3-amino-	0.10282	"	2.699	"	**	0.01028	-
8b	4 ethanesulphonyl-	"	"	13.3462	4.87	0.0197*	"	90
8c	benzotrifluoride	"	"	"	4.80	0.0195*	"	"

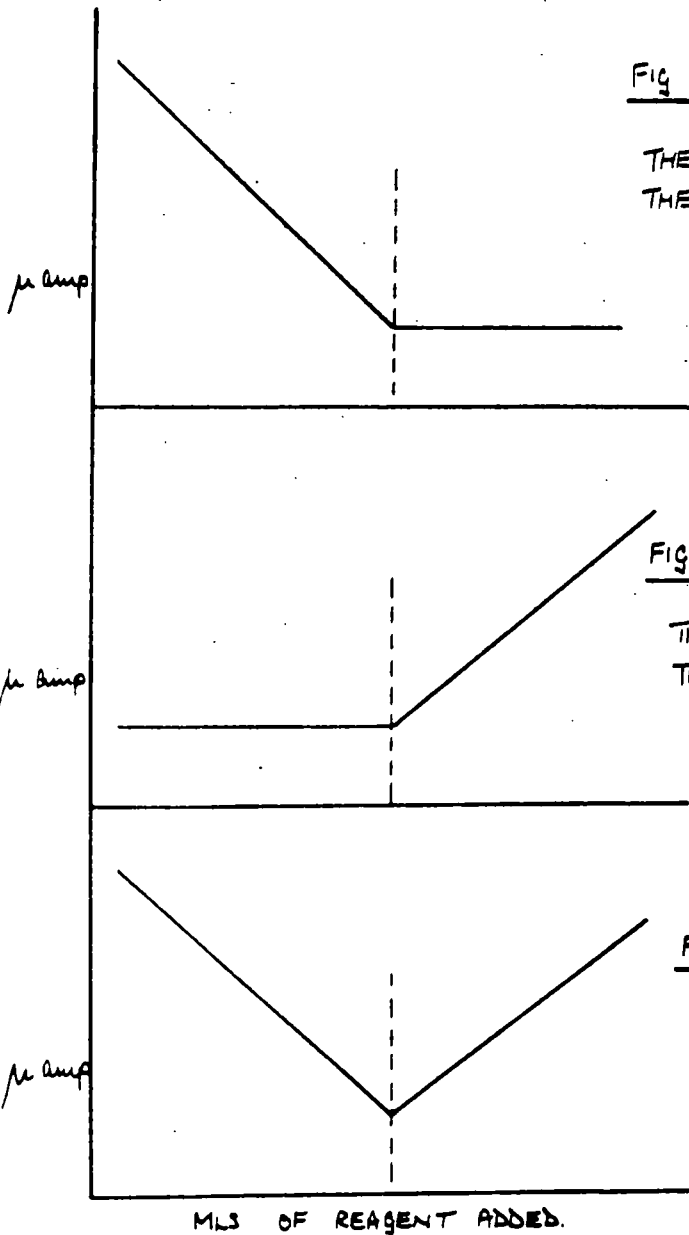

Fig 1

IONS M^+ ARE REDUCIBLE
 THE REAGENT IS NOT REDUCIBLE
 THE COMPLEX IS NOT REDUCIBLE

Fig 2.

IONS M^+ ARE NOT REDUCIBLE
 THE REAGENT IS REDUCIBLE
 THE COMPLEX IS NOT REDUCIBLE

Fig 3

IONS M^+ ARE REDUCIBLE
 THE REAGENT IS REDUCIBLE
 THE COMPLEX IS NOT REDUCIBLE

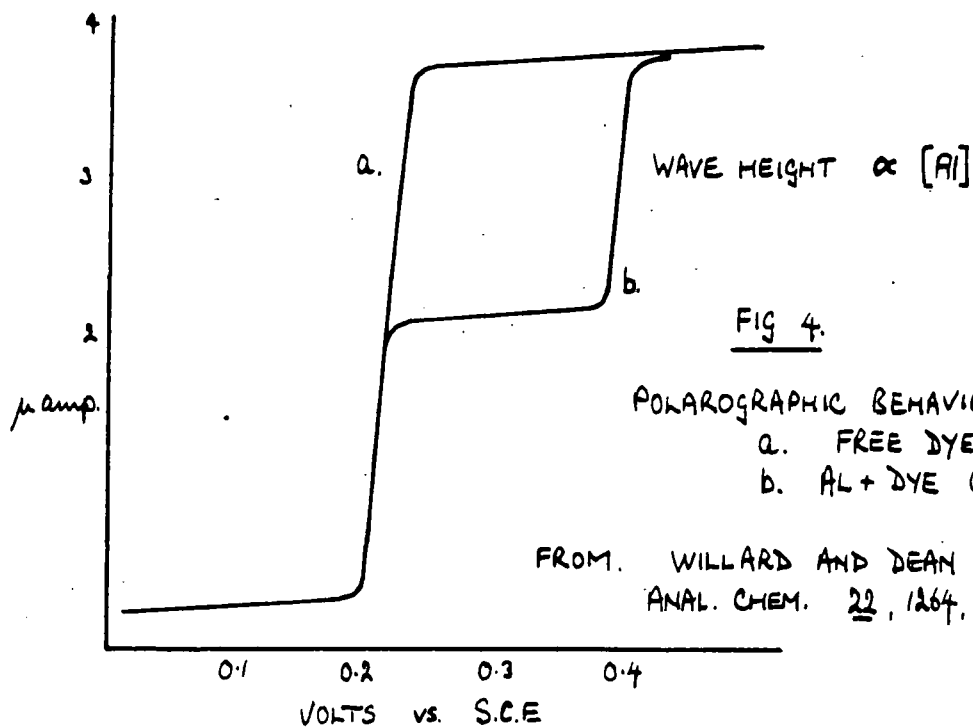

FIG 4.

POLAROGRAPHIC BEHAVIOUR OF
 a. FREE DYE
 b. AL + DYE COMPLEX.

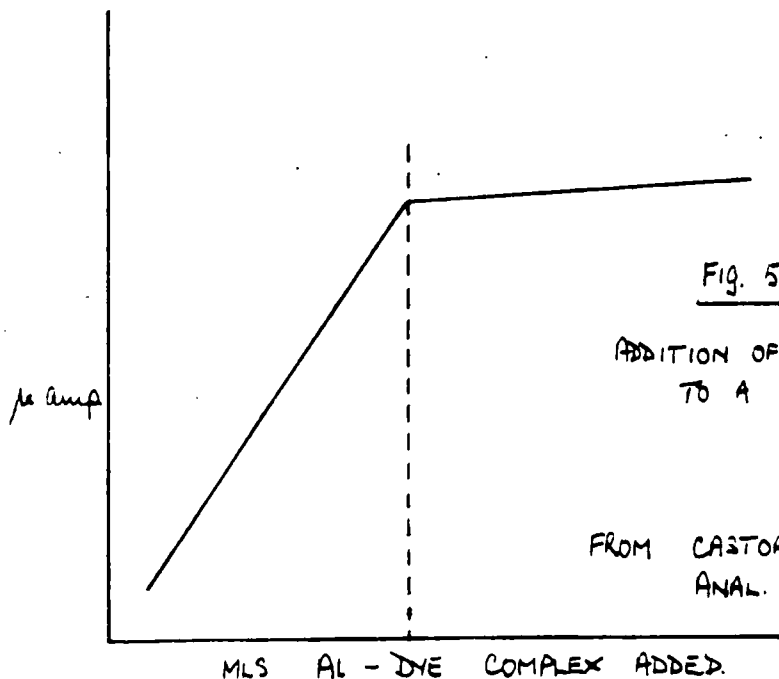

FIG. 5

ADDITION OF ALUMINIUM - DYE COMPLEX
 TO A FLUORIDE SOLUTION.

MLS AL - DYE COMPLEX ADDED.

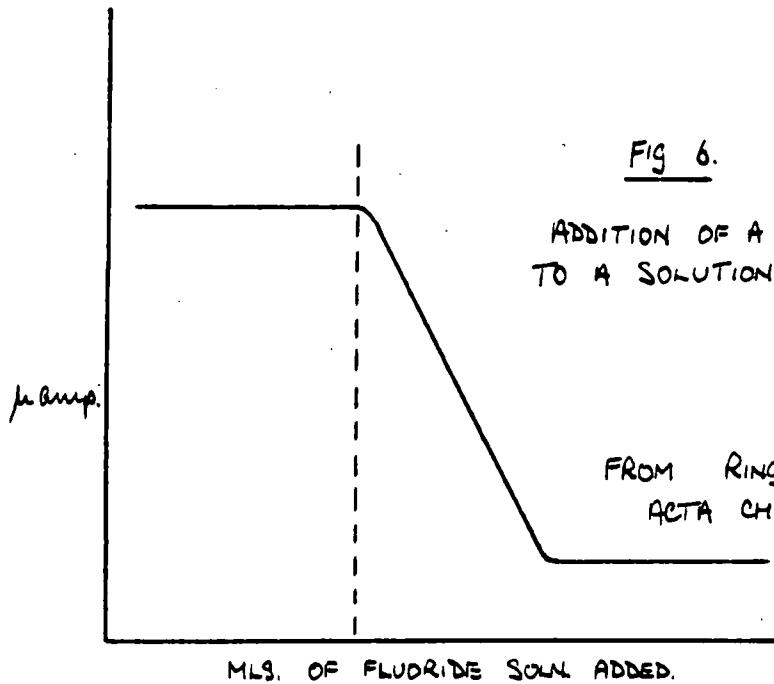

Fig 6.

ADDITION OF A FLUORIDE SOLUTION
TO A SOLUTION CONTAINING Al^{+++}
AND Fe^{+++} IONS.

FROM RINGBOM AND WILKMAN
ACTA CHIM. SCANDINAVICA,
3, 22, 1949.

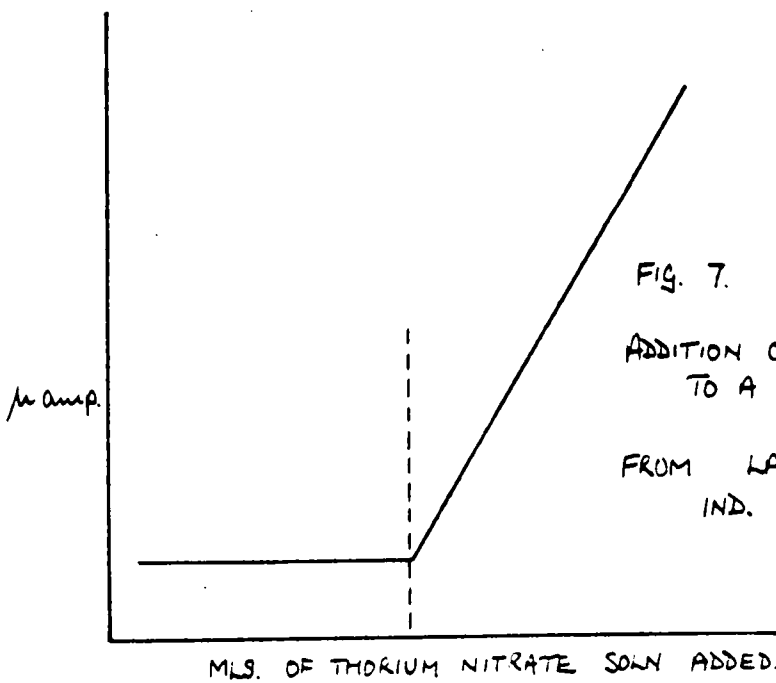

Fig. 7.

ADDITION OF THORIUM NITRATE
TO A FLUORIDE SOLUTION

FROM LANGER
IND. ENG. CHEM. ANAL ED.
12, 511, 1940.

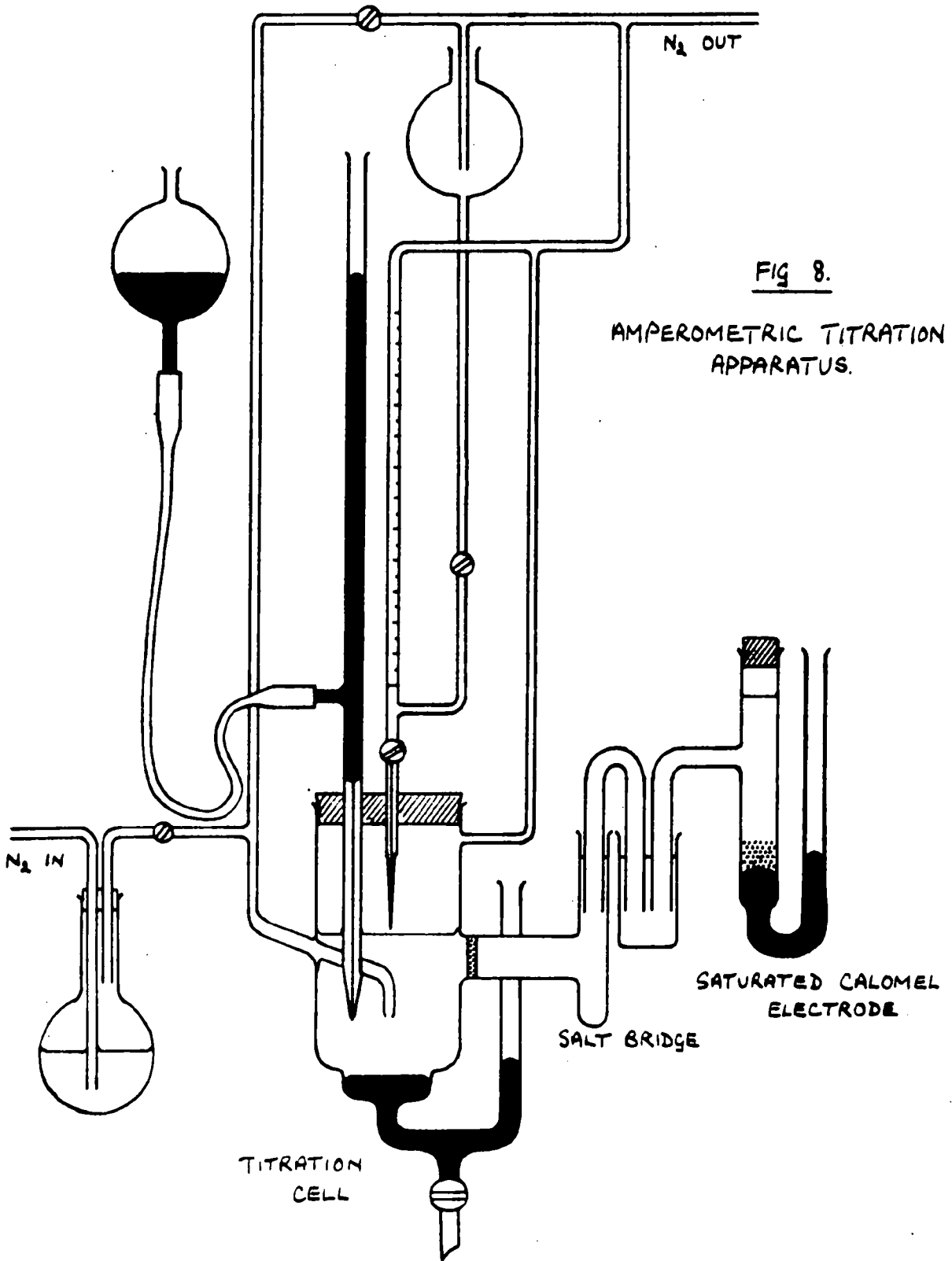
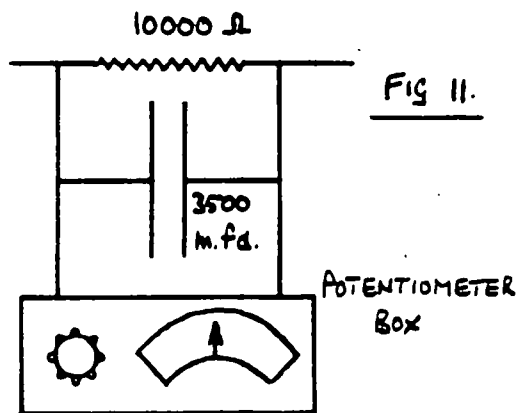
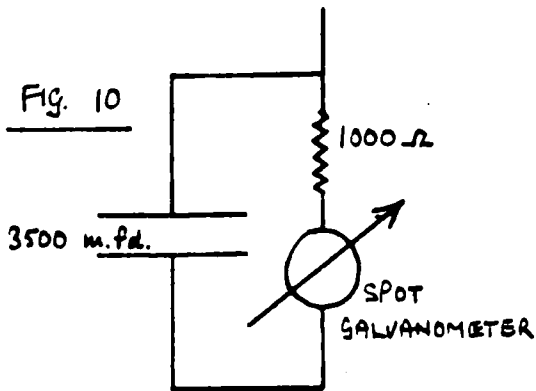
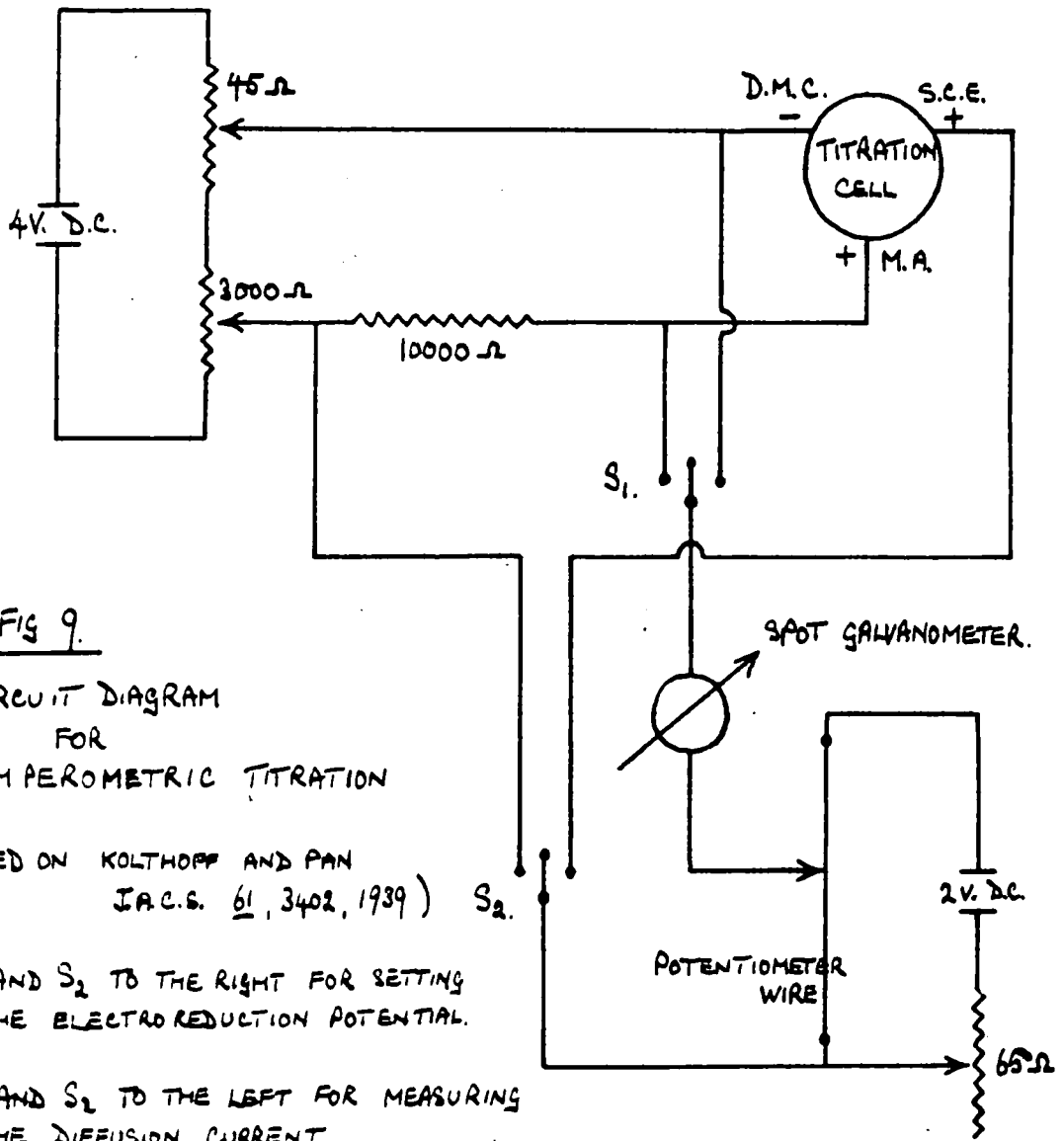
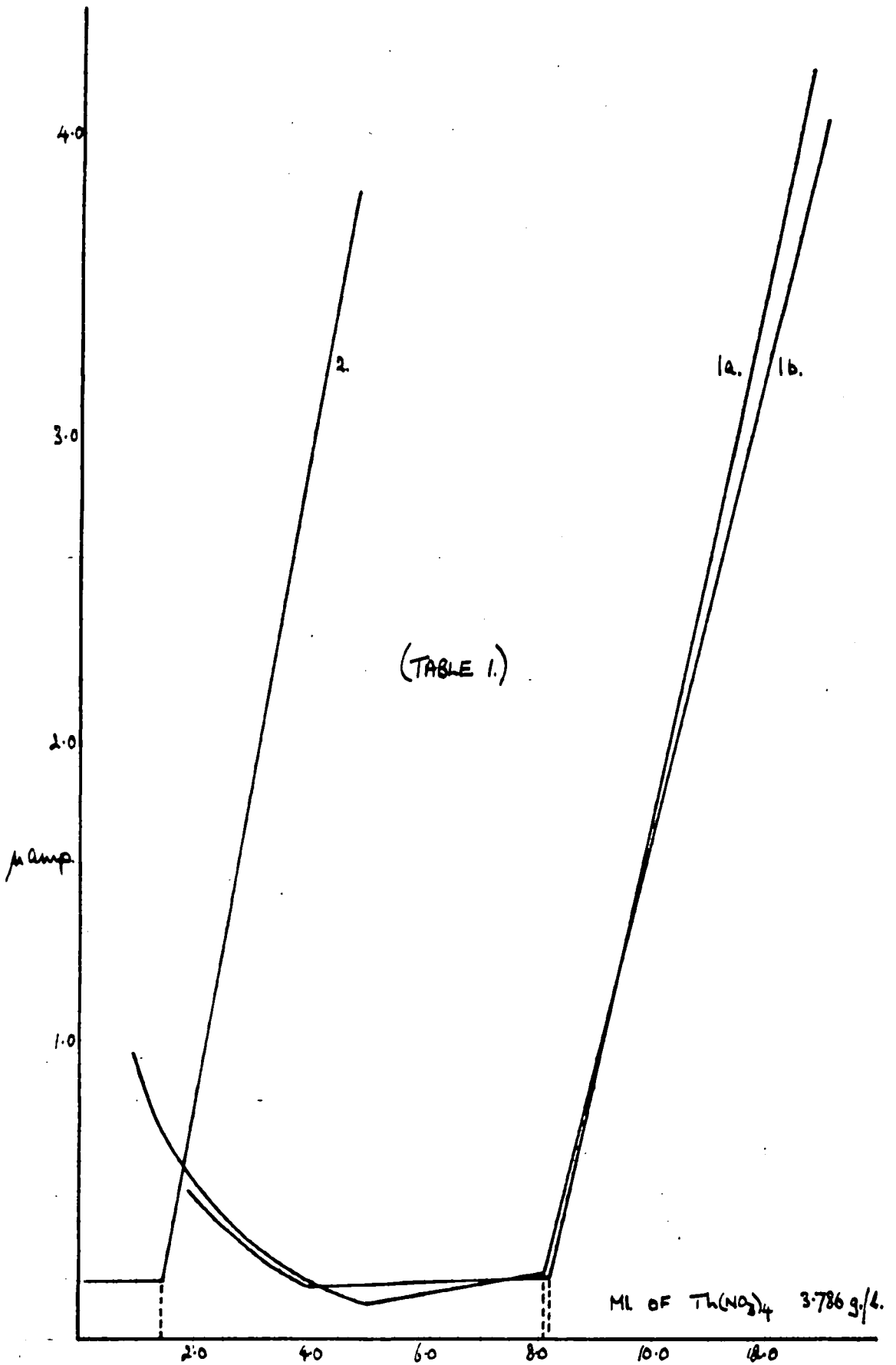
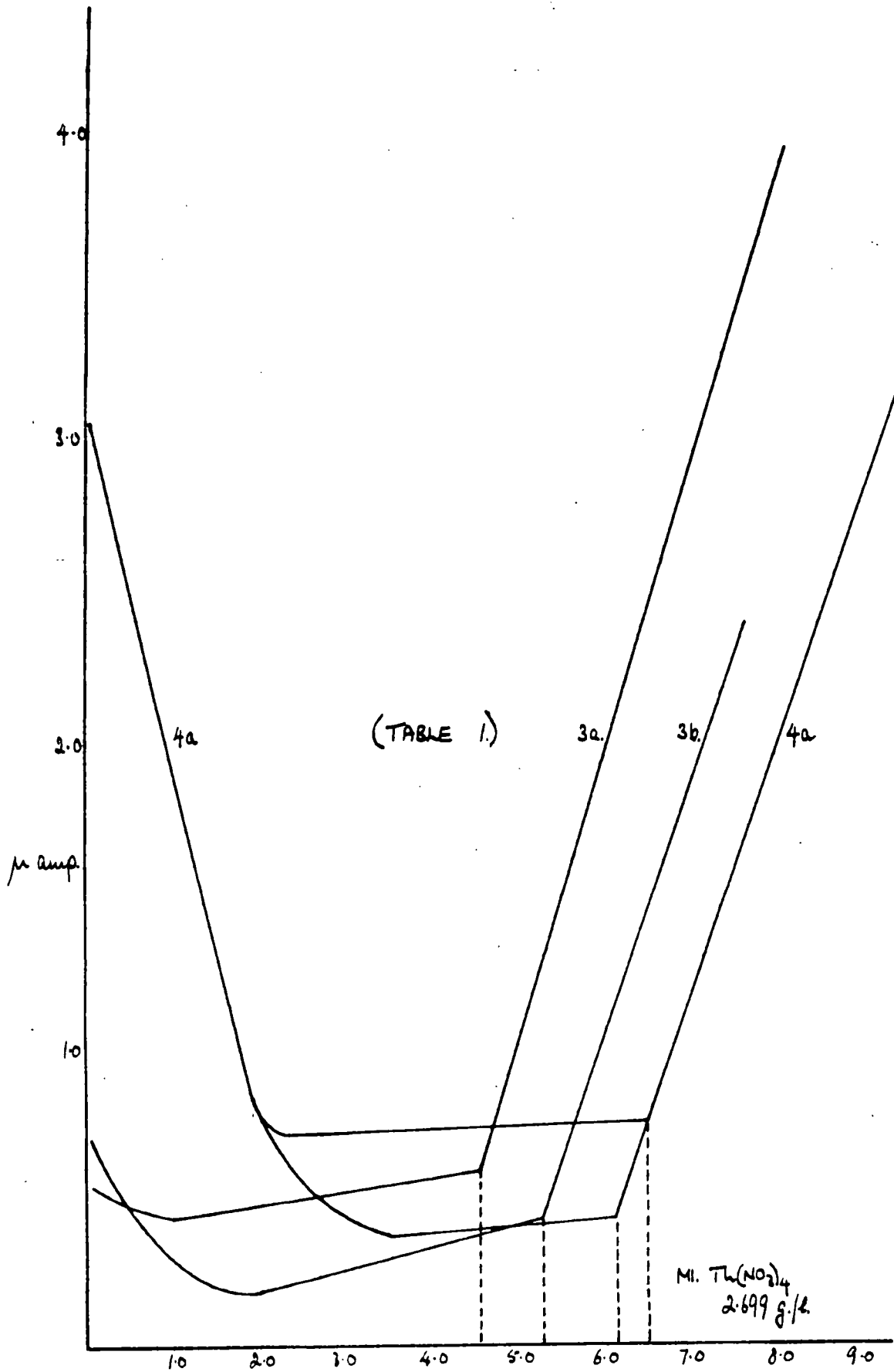

FIG 8.
 AMPEROMETRIC TITRATION
 APPARATUS.



ARRANGEMENTS FOR DAMPING GALVANOMETER OSCILLATIONS
 DUE TO SEPARATE DROPS FROM THE MERCURY CATHODE.





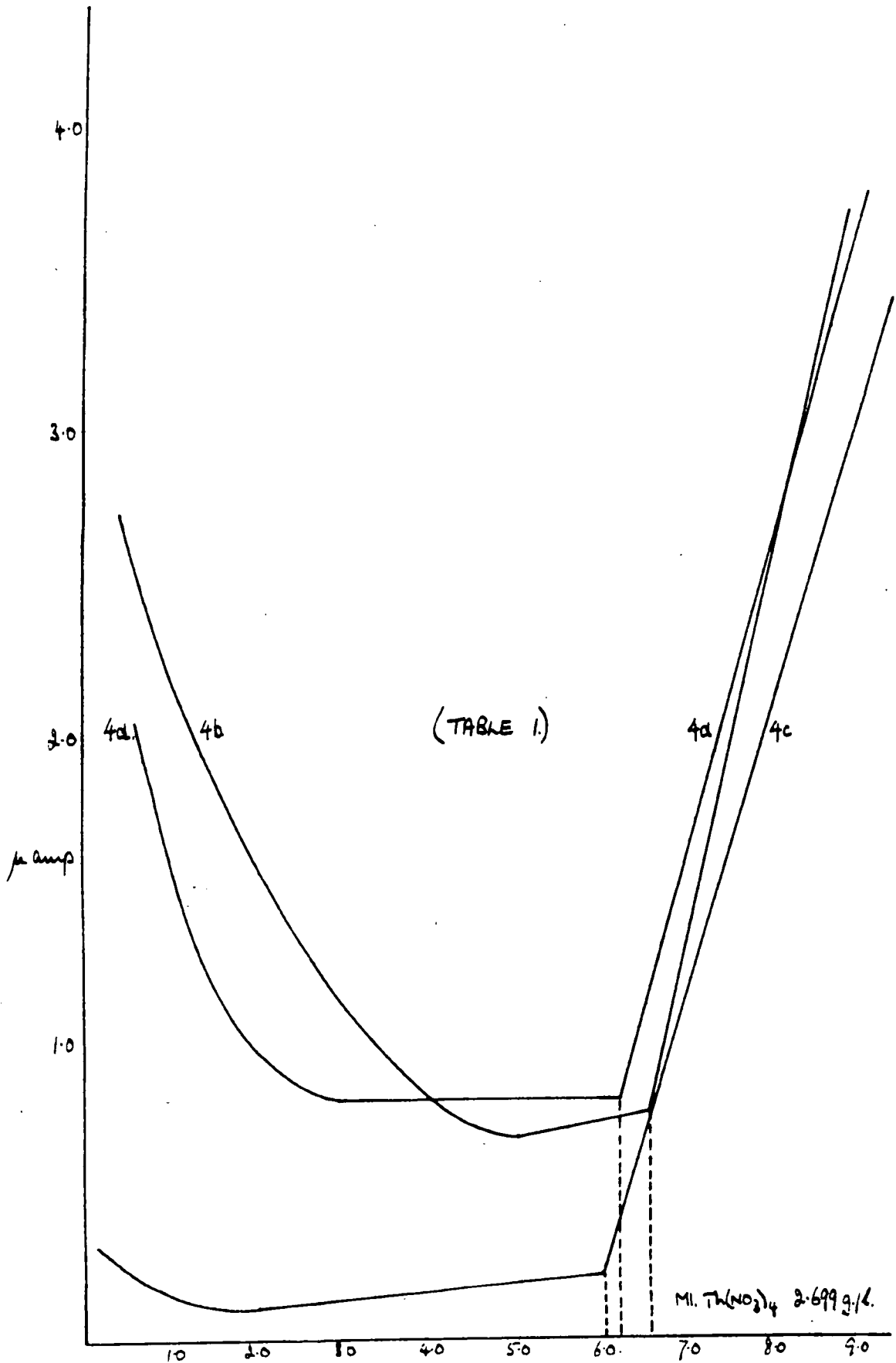

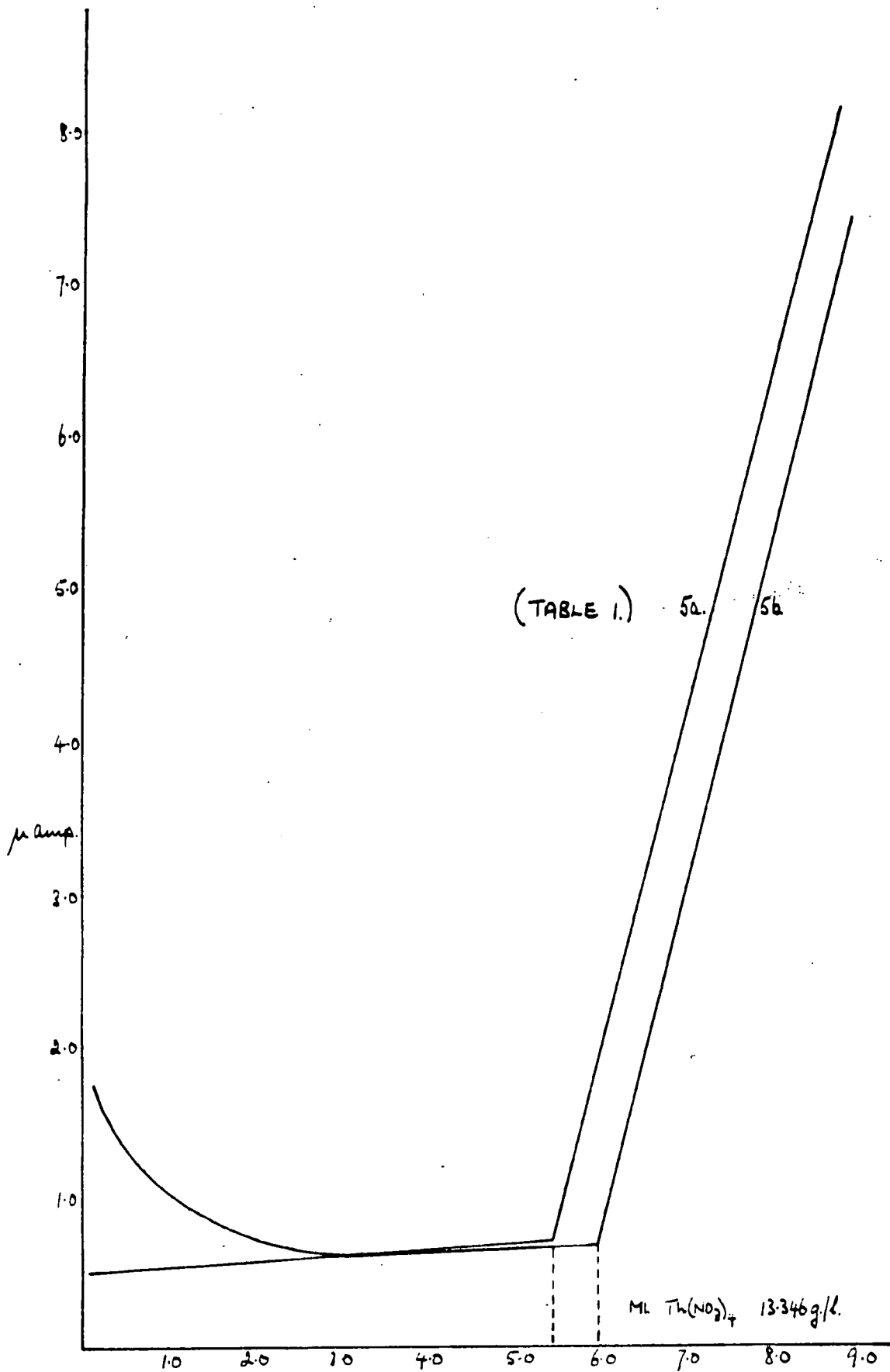

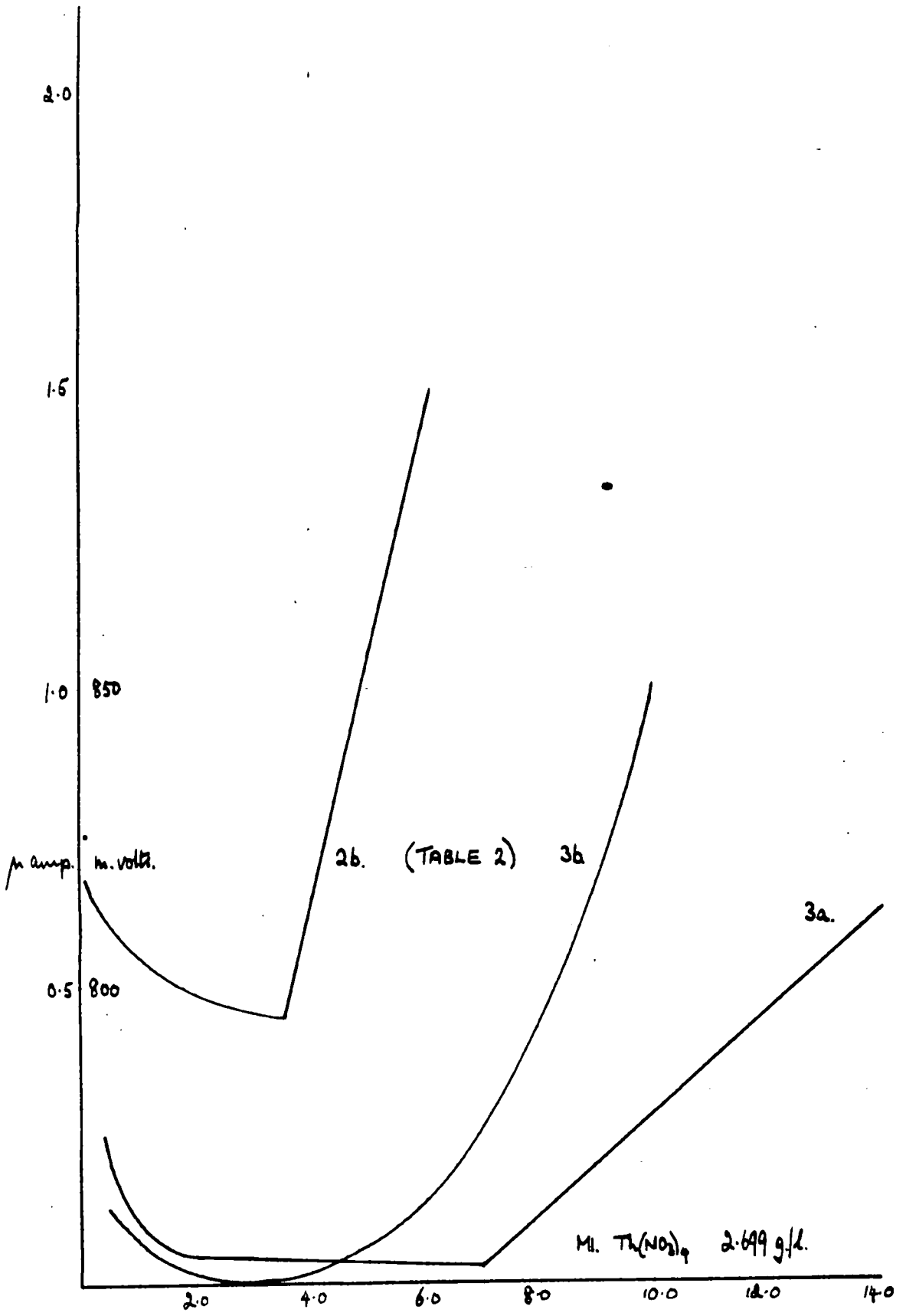

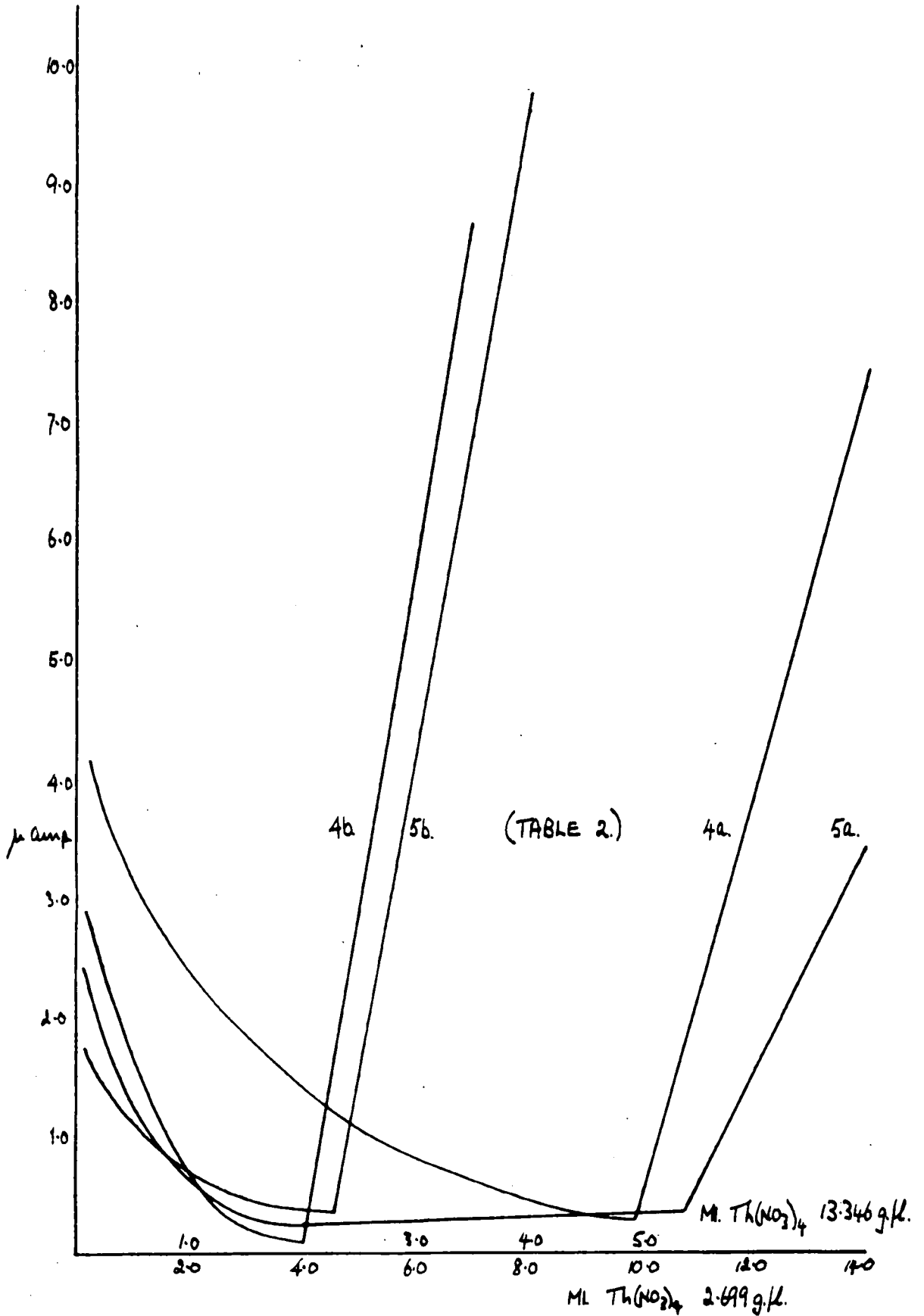

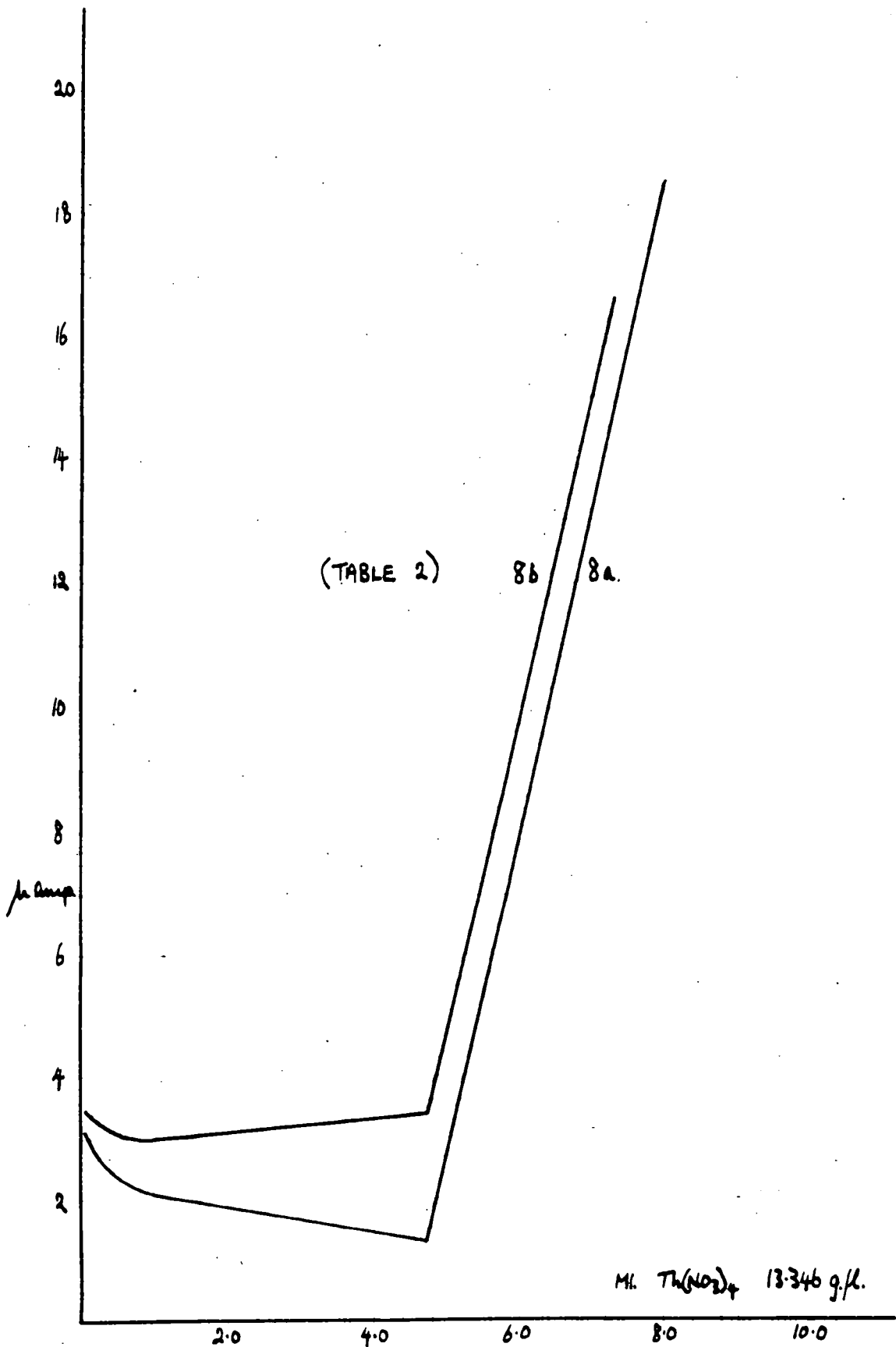

DURHAM UNIVERSITY
SCIENCE
22 DEC 1955
SECTION
LIBRARY