



# Durham E-Theses

---

## *Folio of original compositions*

Alcorn, Michael

### How to cite:

---

Alcorn, Michael (1993) *Folio of original compositions*, Durham theses, Durham University. Available at Durham E-Theses Online: <http://etheses.dur.ac.uk/10186/>

### Use policy

---

The full-text may be used and/or reproduced, and given to third parties in any format or medium, without prior permission or charge, for personal research or study, educational, or not-for-profit purposes provided that:

- a full bibliographic reference is made to the original source
- a [link](#) is made to the metadata record in Durham E-Theses
- the full-text is not changed in any way

The full-text must not be sold in any format or medium without the formal permission of the copyright holders.

Please consult the [full Durham E-Theses policy](#) for further details.

Department of Music  
University of Durham

# **Folio of Original Compositions**

submitted for the Degree of Doctor of Philosophy

1993

**Michael Alcorn**



## Contents

	page no
Contents	1
Declaration	2
Acknowledgements	3
Introduction	4
<b>Recycle</b>	<b>11</b>
<b>Incantation</b>	<b>18</b>
<b>Calypso's Song to Ulysses</b>	<b>31</b>
<b>Making a Song and Dance...</b>	<b>40</b>
<b>Voyager</b>	<b>51</b>
<b>Perichoresis</b>	<b>60</b>
<b>Double Escapement</b>	<b>69</b>
<b>A Slow Dance</b>	<b>80</b>
Appendix One (details of the recordings submitted)	96
Appendix Two ( <i>Incantation</i> : detailed struture)	100
Appendix Three ( <i>Voyager Slides</i> )	103
Appendix Four (examples taken from <i>PitchTwister</i> )	111
Appendix Five (Csound orchestra and score examples)	115

## Declaration

The compositions submitted in this portfolio are my own unaided work and have not previously been submitted for a degree in this or any other University.

Why even a limited no. of writers ~~are~~ were accepted  
over 8 years.



## **Acknowledgements**

There are many people who deserve to be thanked for their support and assistance during the period over which these compositions were written. Particular thanks are due to Professor John Casken for his supervision and inspirational guidance during my time at Durham and to Dr Peter Manning for his persistence in teaching the value of Music 11 as a compositional tool.

I should like to thank many friends and colleagues who encouraged my work, among them Dr Michael Clarke, Dr Anthony Carver and Professor Adrian Thomas.

I am also indebted to *Sequenza*, *Singcircle*, *the Nash Ensemble*, *Capricorn*, *The Queen's University Symphony Orchestra*, *The Ulster Orchestra* and other performers who gave their permission for recordings to be made and submitted for this thesis.

This research could not have taken place without a grant from the Department of Education for Northern Ireland and I am grateful to them for providing a Major State Studentship and additional funding to attend the International Computer Music Conference in Cologne in 1988.

Finally I should like to thank my wife, to whom this folio is dedicated, my sister Elaine and her husband Brian, and particularly my parents, for their tireless support throughout this period of study and for their help at 'those' crucial moments.

# INTRODUCTION

*"The study of the creative process is an extremely delicate one. In truth, it is impossible to observe the inner workings of this process from the outside. It is futile to try and follow its successive phases in someone else's work. It is likewise difficult to observe one's self. Yet it is only by enlisting the aid of introspection that I may have any chance at all of guiding you in this essentially fluctuating matter."*

*Lecture Three: The Composition of Music*

*Poetics of Music*

*Igor Stravinsky*

The works prepared for this folio represent seven years of focussed compositional activity, guided largely by the desire to shrug off the heavy mantle of influences and studied techniques which envelop many young composers, and by the necessity of finding an original voice in a society which so often suggests that there is very little left to say. This search has run parallel with a need to refine (and therefore define) my own compositional technique which has been brought to bear on the increasingly simple musical language to which I am attracted.

The eight works (selected from twelve written during this period) utilize a wide variety of resources (both in terms of compositional techniques and in terms of performers and ensembles) and reveal many of the features which I regard as central to my compositional thinking: energy, movement, dramatic structure and climax. These attributes help create the goal orientated and mosaic-like

structures that characterize the works of this period. Other features, of a musical nature, include a preoccupation with resonance and timbre, with lyricism (especially in later pieces) and with complexities arising from simple rhythmic procedures ('aleatoric counterpoint') or from manipulating simple units of duration.

As will be seen in the commentaries, the titles of the pieces play a large part in the compositional processes and qualities of each work. In most cases they are descriptive of some musical or gestural process or event which is central to the piece.

Three of the (recent) compositions in the portfolio employ electro-acoustic resources and thereby reflect my growing desire to integrate technology into my work. Although I have worked (and taught) in the studio for a number of years it has taken me a while to understand how such resources best suit my compositional needs. The clearest indication of this in the folio is the electro-acoustic material devised for *A Slow Dance*. These (often simple) sounds were created using only one resource (Csound) and borrow many of the stylistic qualities of my instrumental music. This link with the instrumental music is a two-way process. Several of my pieces draw upon processes or techniques devised in the studio and apply them as structural, timbral or textural processes in the instrumental writing. Large sections of the orchestral piece *Incantation* borrow technological ideas - for example labyrinth (multiple two-track tape delays), delay line effects, and 'white noise' ('highest note possible' strings imitate this). Other pieces have even attempted to simulate the electrical processes at work in the studio; electrical states in circuits such as resistance, capacitance and the effect of components such as transformers and diodes finding musical analogies in early pieces (not included here).

Taking an overview of the portfolio the compositions seem to group themselves in different ways. In some respects they appear as a single line, each subsequent piece growing from the inconclusive threads of the previous piece. In other ways they seem to divide into two groups: pieces which experiment principally with compositional techniques (*Recycle, Incantation, Voyager*) and pieces which experiment with musical material (*Making a Song and Dance..., Perichoresis, A Slow Dance*). I also see them in the light of musical discoveries made before or at the time of composing each piece. For example *Calypso's Song to Ulysses* was written at a time when I had been listening to jazz and this may be reflected in the choice of ensemble and prominence given to the soprano saxophone (the playing styles and sounds of Jan Garbarek and Courtney Pine were in mind when making this choice); *Making a Song and Dance...* followed a period of studying Scandinavian music and this is to some extent reflected in the music. More recently I have spent considerable time studying Irish traditional music, and the music of John Sheppard which has had a bearing on the soundworld of *A Slow Dance*.

In purely musical terms the pieces have changed considerably. Generally they show a gradually refined compositional technique: purer and simpler harmonic events, less cluttered textures, more clearly delineated structural objectives and a simpler rhythmic manipulation which sacrifices complexity for a desire to ensure correct heterophonic alignment (where required) in performance.

In preparing these commentaries I have been as surprised by the consistencies across the works as I have been by the change. Despite the time span and (for me at least) the gulf in the musical language which separates *Recycle* and *A Slow Dance* I see numerous harmonic, stylistic and gestural fingerprints which unite the works. In particular I see a consistent harmonic language which has

changed only in the fact that the corners have been rounded off jagged melodic lines, and chords and aggregates have acquired more resonant qualities. I also identify a preoccupation with cluster-like harmony throughout the works: much of the orchestral piece *Incantation* is based on cluster formations arising from the compositional method, and both *Perichoresis* and *A Slow Dance* use this type of harmony at some point. Despite the general change in harmonic rhythm and pacing which has occurred across the portfolio (more recent works move at a relatively slow rate) I see similar processes at work in defining structures in all of them: that is, a single thread gathering other materials or instruments and the instrumental fabric continuing by replication and development.

Beyond this the works all show a concern for texture, particularly (what I regard as) transparent textures. At one stage the early pieces in the portfolio were criticized for being 'superficial' or at least 'concerned only with surface embellishment'. If anything this comment helped me realize that such embellishment was a strength in the music and I became more consciously interested in it for its own sake. In looking for an analogy I became struck by the detail in many types of embroidery and in Irish lace. Here the fine and often delicate detail is both functional (its patterns form a strong fabric) and also attractive to the eye. Similarly I see the surface activity of my music as being the strength of the material (not an animation of the harmonic progression) and the rationale behind its creation. I regard all works after *Calypso's Song to Ulysses* as being influenced by such textural concerns.

In terms of my approach to the process of composition I see a number of changes and consistencies. Throughout these pieces my compositional sketching has begun with the most rigorous procedures: charts for pitch material, chordal formations, numerical patterns for controlling duration and structure, and computer programs for controlling pre-defined parameters (see

Appendices). This is without doubt one of the most crucial parts of the compositional process for me and one which serves to suggest a general way in which the work should develop in terms of harmony, gesture or structure (although it need not be the beginning of the piece). However, in all of these works the procedure has broken down, or more accurately, I have dispensed with the procedure in pursuit of more intuitive methods at a later stage. Thus the function of the process is to suggest those ideas which may be beyond our experience and to fuel the act of composition.

This has close links with my views of certain areas of electro-acoustic music which I feel are often guided by accidental happenings outside the composer's control. When working in the analogue domain this is particularly true. Several of the sounds in the electro-acoustic pieces of the folio evolved in this way (for example, the opening sound of *Voyager* was created from feedback from a *Yamaha SPX90 II* which is controlled and filtered through a mixing desk). As composers working in this particular genre it becomes our function to observe and understand these occurrences and, if they are worthy of development, to implement them in the creative process. In this way I draw a parallel to the use of processes in my instrumental music.

At one stage several years ago I became very anxious about the repeated rejection of these processes during each composition but have since come to accept it quite happily as an idiosyncrasy of my work.

In conclusion, whilst it is not uncommon for one to feel that the most recently finished work is closest to one's artistic ambitions, it can truthfully be said that *A Slow Dance* proffered fewer of the inconclusive threads mentioned earlier, and in other respects created a clear harmonic, gestural and structural path for me to explore in subsequent works.

In the commentaries that follow I have attempted to highlight those features and procedures which are peculiar to each piece and those which are characteristic of my compositional style, and to present an overview of the structural and organisational processes at work. Although many of these features could be examined in several of the compositions I have chosen to illustrate them in particular pieces where they are most clearly exemplified. The following are the principal attributes and features examined in each work (not necessarily in the order in which they are discussed):

*Recycle*        structure, harmonic language & style

*Incantation*    structure, harmonic & melodic processes, orchestration

*Calypso's Song to Ulysses*

                  structure, text and musical relationships, structural processes

*Making a Song and Dance . . .*

                  structure, quotation, harmonic and melodic processes

                  relating to the quotation

*Voyager*        structure, educational considerations, 'aleatoric' writing,  
                  electro-acoustic resources

*Perichoresis*    structure, influence of the title on structure and musical  
                  material, 'aleatoric' writing

***Double Escapement***

structure, harmonic, melodic and rhythmic  
procedures, electro-acoustic resources

***A Slow Dance***

structure, relationship between text and music, use of Csound

The approach taken in the examination of these features relies heavily on information presented in the final score and in the preparatory sketches which led to the final copies. There are instances where the clear recollection of the intuitive and systematic procedures in any particular work has faded, largely because of the passage of time and, as mentioned above, because pieces evolved in their own right once the original compositional procedures were abandoned. On the other hand it has been possible to assume the role of a musicologist and unearth some of the unconscious processes at work which were not apparent at the time of composition.

Above all these pieces stand or fall not because of what is written in these commentaries, nor because of the processes used in creating them, but because of the energy or atmosphere they might create in performance and the spiritual effect they might have on the listener.



# Recycle

(1987)

for chamber ensemble

(duration: 10')

*first performance:*                      *University of Durham*  
    *Players from the Northern Sinfonia*  
    *March 1987*

*other performances:*                      *Haenjo Ensemble*  
    *Accents Festival, Dublin*  
    *April 1990*

## Introduction

In retrospect this piece still holds particular charms for me, not least because within it one can see many of the harmonic, melodic, gestural and stylistic fingerprints of my later music. Of the pieces in the portfolio it probably bears the closest signs of influence from other composers. However it is through a process of abstraction and integration that these features arise, and not through direct borrowing. Without doubt the greatest of these influences was the music of Harrison Birtwistle (particularly *Secret Theatre and Carmen Arcadiae Mechanicae Perpetuum*) and this may well have contributed to the rhythmic articulation of this piece.

The inclusion of the piece here is justified in that it was one of the earliest works to show coherence in its realisation (i.e. performance) and in its methods of organisation. It also stands as an example of a maturing compositional voice exploring materials, of an often rich and complex nature, without total control. Despite this, the piece presents many interesting and attractive features which,

as mentioned above, became the basis of many of the works in the last five years. Examining this piece six years later I feel removed from the compositional processes used and to some extent the musical language employed.

My pieces from around this period were concerned with the concept of cycles. A wind quintet written at this time (*In a Roundabout Way*) and the work in question rely on this cyclic idea to inform much of the musical material. In the latter case this guides the structural and harmonic ideas as will be shown. What is also important about this piece is that it is the only composition of recent years which does not utilize a 'hidden agenda' (usually associated with the title) to control or assist in the organisation of the materials. Typically, later works have at least some programmatic element to assist in this process.

### **Structure**

As the title suggests, *Recycle* was inspired by the possibilities of re-using or re-exploring particular musical ideas. The dictionary defines the word *recycle* as the act of passing a substance through a system for further treatment or use. This can be applied to the handling of both structural, gestural and harmonic ideas.

Three basic types of music can be identified and traced within the piece:

- A - fast, punctuating or accumulating textures
- B - *senza misura* passages
- C - lyrical duets (or solo passages based on duet material)

These are distributed freely within a mosaic-like structure (as shown in Figure 1).

This type of structure - containing a collection of fragments which are linked via voice leading, instrumentation or gesture - is common to my compositions up to *Voyager* and *Perichoresis*, later works relying on simpler structures and a greater concentration on any one idea. The attraction of the mosaic-like structure was the possibility of linking together short sections of music by cross-cutting quickly between the various musical ideas.

Although Figure 1 clearly identifies the origin of each section of the piece (in terms of their relationship to the types of music A,B,C listed above) it does not reveal the changes which occur to each type of music across the piece. For example, the A-type music (chord and rising chromatic cluster-like material, fast counterpoint) is influenced by the B-type music (rapidly repeated notes). This manifests itself in the music at bar 109. Also, the final statement of A (bar 198) shows an influence of C-type music (lyrical and relatively slower in speed). The climax of the piece (bar 164) could be regarded as a combination of A & B (the opening chord of the piece cross-fertilized with the repeated note idea).

# RECYCLE - Basic structure

Figure 1

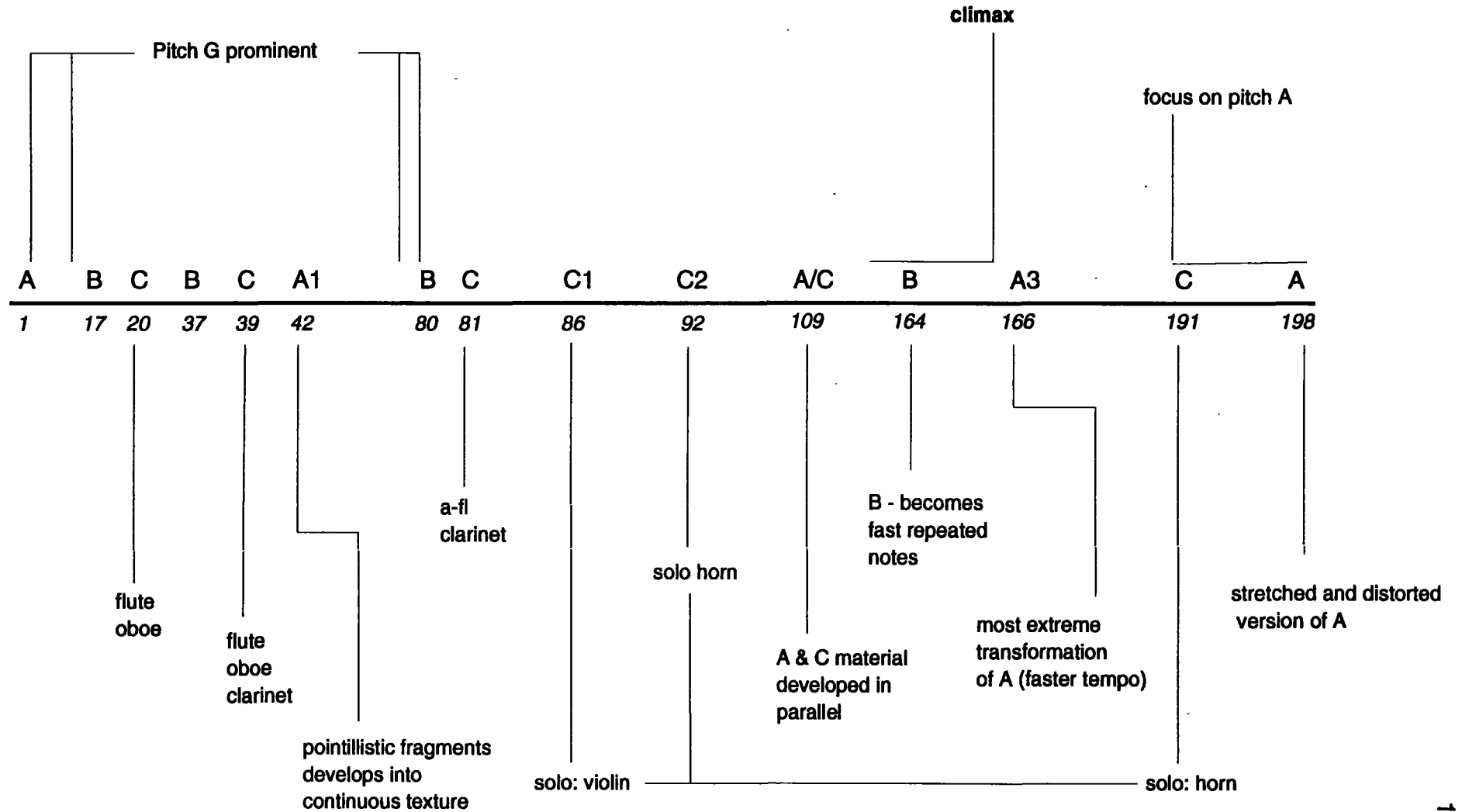

### Compositional processes

The majority of the musical material of *Recycle* stems from an 8 note pitch set shown in Figure 2a.

Figure 2

Figure 2 consists of two musical staves, 2A and 2B, illustrating the 'Recycle Row' and its applications.

Staff 2A, labeled 'RECYCLE ROW', shows a sequence of notes on a treble clef staff. Handwritten annotations identify intervals: 'TRITONE' between the first and second notes, and 'TONE' between the second and third, third and fourth, and fourth and fifth notes. A bracket above the last three notes is labeled 'TRITONES'. To the right, 'TRITONE + TONE FORMATIONS' shows three chords, each consisting of a tritone and a tone.

Staff 2B, labeled '[HORN]', shows a horn part starting with a dynamic marking 'sfz pp'. It features a sequence of notes with a slur and a '6' above it. Below the staff, the notes are identified as 'FROM THE ROW: 5 7 5 6 7 8'.

This set, constructed from the intervals of tones and tri-tones (freely chosen), was used to provide basic melodic material such as the opening horn gesture (shown in example 2b - transposed from the original pitches of the set). It was also used to create the grid shown in example 3a which provided additional melodic and harmonic material. The arrows, numbered 1 to 7, identify pitch sets which were implemented as chords (shown in example 3b below the grid) by free selection from the available pitches in any one row. These new chords (or pitch fields) were then implemented in the composition, either by moving abruptly from chord to chord (as is the case in faster passages) or by a gradual process of cross-fading between the chords (used in slower passages). The chords shown in example 3b are used in one of the lyrical passages of the piece (b20-28) with the 'cross-fading' process noted above linking one chord to the next.

Figure 3

3A

RECYCLE PITCH GRID

1 2 4 6

1 5

3

7

3B RECYCLE CHORDS — [BARS 20-28]

1 2 3 4 5 6 7 8

### **Cadential chords & key harmonic points**

Each short section of the structure is driven towards a momentary climax (either a chord or series of chords) or a *senza misura* passage which serves to relieve the dramatic tension. These chords are again derived (or distorted) from the pitch grid and arranged freely for dramatic purposes. Figure 4 shows the principle harmonic regions of *Recycle* and indicates the importance of the pitch G (the first note in the exposed horn line at the opening) in nine of the eleven regions. In each case the harmonies include cluster-like formations usually in the upper treble register, and in all but two cases the harmonies lie in the high bass/treble register adding to the dramatic effect of the chords.

In all other respects the compositional processes used here were freely organised, control of rhythmic organisation and of timbral considerations being based on the desire to create strong and focussed musical gestures (such as the opening, or the repeated chords at bar 164).

As mentioned at the beginning of the commentary this piece is important as a seminal work. It contains many signposts of processes and techniques that have developed in more recent pieces, and includes the use of limited aleatoricism (used tentatively here in the percussion part at bar 93ff), simple rhythmic gesture (for example at bar 139) and a mosaic structural process.

Despite its abrasive harmonies (resulting from the overuse of sevenths and minor ninths) and its over-fragmented structure it remains a powerful and dramatic work within the context of my early compositions.

Figure 4

**RECYCLE — 'KEY' HARMONIC REGIONS**

The image displays two systems of musical notation. Each system consists of a treble clef staff and a bass clef staff. The first system includes notes and chord symbols: b1, b13, b16, b17, b26, b37, b76, and b79. The second system includes notes and chord symbols: b80, b163, and b203. The notation includes various chord symbols such as b1, b13, b16, b17, b26, b37, b76, b79, b80, b163, and b203, along with notes and stems.



**Incantation****(1987)**

for orchestra

(duration: 14')

*First performance:*

*University of Durham Chamber Orchestra  
18 May 1987  
University College, University of Durham  
conductor: Andrew MacFarlane*

*Subsequent performances:*

*The Ulster Orchestra  
17 May 1992  
Elmwood Hall, Belfast  
conductor Richard Bernas*

*The Queen's University Symphony Orchestra  
8 December 1992  
Whitla Hall, Belfast  
conductor: Michael Alcorn*

**Introduction**

It had been my desire for some time to flex my compositional muscles on the rich resources of the orchestra. Up until this point my pieces had concentrated on solo instruments or chamber combinations, and thus, given my growing interest in texture, the attraction of a broader palette seemed reasonable.

Given that this was only my fifth composition, the challenges which lay ahead were considerable: particularly to do with large-scale structure, instrumentation and orchestration. Equally, questions about the soundworlds to be employed and the methods of organisation were prominent at an early stage. With regard to the soundworlds employed, my growing disillusionment with the harmonic

language of pieces such as *Recycle* and my desire to work with a more fluid and conjunct language suggested that the music should grow not from a series of vertical aggregates, as was the case in a number of earlier pieces, but from a linear construction (scale). This approach would address a number of concerns that I had at this stage; namely that working with a series of aggregates treating them as harmonic and melodic fields, produces a unified language but is highly inflexible and provides only relatively fixed methods of moving from one chord to another. Instead, I was looking for a 'formula' that would provide unified harmonic and linear material equivalent to the diatonic scale and an associated hierarchy of chords and melodic possibilities. The answer stemmed from the creation of a 'macro-scale' which extends from the lowest register of the orchestra to the highest. This will be discussed in greater detail below.

As with most of my pieces the title provided one of the initial impulses in the compositional process. The dictionary defines *Incantation* as a ritual recitation of magic words or sounds, the formulaic words or sounds used, a magic spell. The influence of these meanings can be found at various structural and thematic levels in the piece especially in the 'mantra-like chanting' of gestures such as the G / A pitches at the opening and in the F# / G in the middle section. Also important at an early stage of the composition was the desire to embody within the piece the idea of ritual and dance. An imaginary ballet was created which presents in the first and third sections a series of dance-like gestures, groups of dancers working in synchronisation, other dancing freely. From this two principal characters emerge in the second section: the violin and clarinet who weave a slow and seductive dance through some of the pitch material of the opening of the scale. An extended passage at letter V draws together the entire

orchestral mass for the first time and provides the most concentrated dance-like material of the piece, perhaps representing the final energy required to cast the spell.

**Macro Scale**

This scale was to provide a considerable amount of the harmonic and melodic material for *Incantation* and was derived from a rotating sequence of intervals which ascends and descends from a central point (or tonal centre) to the registral extremities of the orchestra. The sequence of intervals (I refer to this as an algorithm) and the rotation process are shown below. The first few octaves of the scale are shown in Figure 5.

algorithm: 1 2 1 1 2 2 1  
(semitone steps)

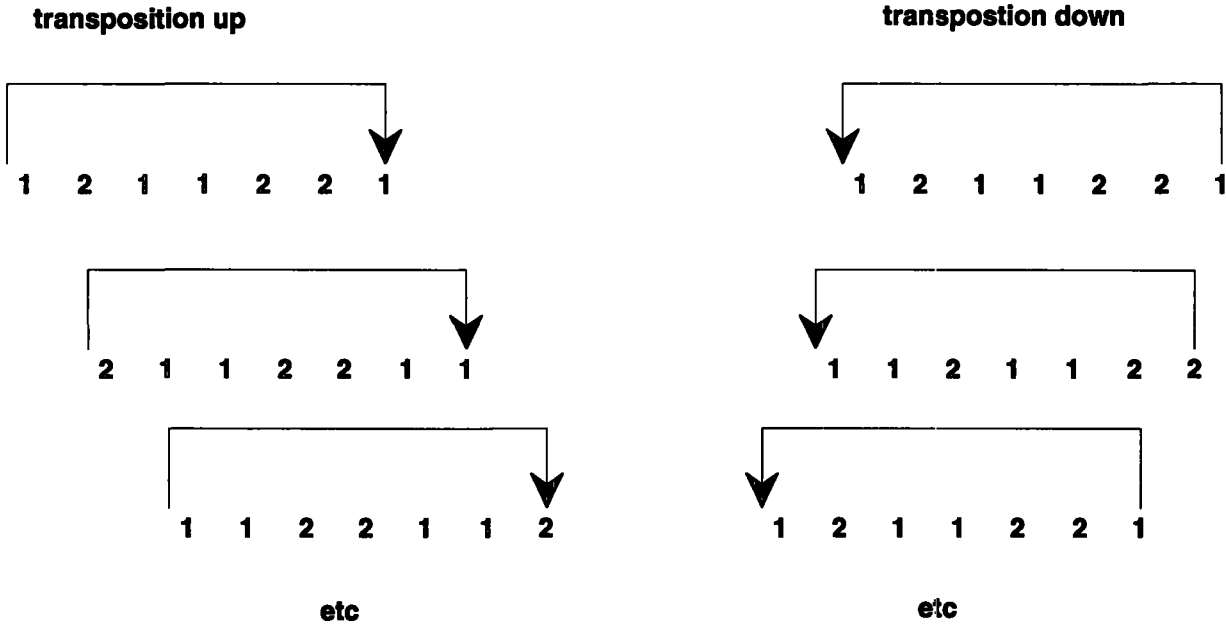

**Example 5**

**INCANTATION — MACRO SCALE**

intervals: (up) 1 2 1 1 2 2 1 | 2 1 1 2 2 1 1 | 1 1 2 2 1 1 2 | etc ↗

intervals: (down) 1 1 2 1 1 2 2 | 2 1 1 2 1 1 2 | 2 2 1 1 2 1 1 | etc →

The image shows two staves of musical notation. The top staff is labeled 'INCANTATION — MACRO SCALE' and shows an ascending scale. Above the staff, interval numbers are listed: 1, 2, 1, 1, 2, 2, 1, followed by a bar line, then 2, 1, 1, 2, 2, 1, 1, followed by another bar line, then 1, 1, 2, 2, 1, 1, 2, followed by 'etc' with an arrow pointing up and right. A bracket above the staff spans five notes (from the second bar line to the end of the third bar line) and is marked with an 'X'. The notes are written on a treble clef staff with a key signature of one sharp (F#). The bottom staff shows a descending scale with interval numbers: 1, 1, 2, 1, 1, 2, 2, followed by a bar line, then 2, 1, 1, 2, 1, 1, 2, followed by another bar line, then 2, 2, 1, 1, 2, 1, 1, followed by 'etc' with an arrow pointing right. The notes are written on a bass clef staff with a key signature of one sharp (F#).

What is perhaps most interesting about the scale is its lack of uniformity; within the span of six octaves above the central pitch (f#) there is virtually no repetition in the sequence of pitches. Furthermore, the rotation of the algorithm ensures that the intervallic succession is always varied (for example the rotation process produces a cluster of five semitones - marked X in the diagram) and provides octave doubling in certain registers.

The scale was used to create the following compositional materials:

- harmonic progressions produced by 'filtering' out unwanted pitches (a term derived from electro-acoustic composition where particular parts of a spectrum can be isolated).
- melodic material produced by intuitive selection from the scale
- textural and transitional 'padding'

None of these materials was used without the possibility of modification and, as the examples below will show, 'wrong notes' or as I prefer to call them 'modulations' are used freely to colour the scale. A notable example is the thematic material shown in Figure 6 where a C natural is exchanged for the prescribed C# of the scale.

**Figure 6**

Handwritten musical notation for Violin 3, Bar 26. The notation is on a single staff with a treble clef and a key signature of one sharp (F#). The music consists of several chords and melodic lines. A handwritten annotation 'c4 for C# of scale' with an arrow points to a C4 note in the second measure. There are two triplets marked with a '3' and a bracket. The first triplet is in the first measure, and the second is in the fourth measure. The word 'BAR 26' is written below the first measure.

Other examples include:

- Figure 7 which is a reduction of the harmonic material from bar 213 (letter V) and illustrates the 'filtering' process at work.
- Figure 8 which shows the use of the scale to provide two basic chords connected by melodic material drawn from the scale (the e flat (horn II) in the first chord is a 'passing note').
- Figure 9 shows how aleatoric techniques were used to create a texture from the scale.

**Figure 7**

Figure 7 consists of two systems of musical notation, each with a treble and bass staff. The first system covers measures b213 to b215. Measure b213 shows a chord with notes G#4, A4, B4, C5 in the treble and G#2, A2, B2, C3 in the bass. Measure b214 shows a chord with notes A#4, B4, C5 in the treble and B2, C3, D3 in the bass. Measure b215 shows a chord with notes B4, C5 in the treble and C3, D3, E3 in the bass. The second system covers measures b216 to b217. Measure b216 shows a chord with notes B4, C5 in the treble and D3, E3, F3 in the bass. Measure b217 shows a chord with notes C5, D5 in the treble and G#2, A2, B2 in the bass. The word 'etc' is written at the end of the second system. Pitches in brackets, such as (A) in measure b214 and (B) in measure b215, indicate added notes.

Pitches in brackets = added notes

Figure 8

**Figure 8** Musical score for a symphony orchestra, featuring woodwinds, brass, strings, and percussion. The score includes a tempo marking of  $\text{♩} = 96$  and an **ACCEL** (accelerando) instruction. The music is in 4/4 time, with a key signature of one flat. The score is divided into measures 4, 5, and 6, with measure 6 marked as the start of an accelerated section. Various performance instructions such as *sfz*, *sempre*, *p*, and *mf* are present throughout.

**Instrumentation:**

- Flutes:** Fl<sub>1</sub>, Fl<sub>2</sub>
- Oboes:** Ob<sub>1</sub>, Ob<sub>2</sub>
- Clarinets:** Cl<sub>1</sub>, Cl<sub>2</sub>
- Bassoons:** Bsn<sub>1</sub>, Bsn<sub>2</sub>
- Horns:** Hn<sub>1</sub>, Hn<sub>2</sub>, Hn<sub>3</sub>, Hn<sub>4</sub>
- Trumpets:** Tpt<sub>1</sub>, Tpt<sub>2</sub>
- Timpani:** Trb
- Tuba:** Tba
- Percussion:** Pn, Vib, Per, Xylo
- Violins:** VI<sub>1</sub>, VI<sub>2</sub>
- Viola:** Vla
- Violoncello:** Vc
- Double Bass:** Cb

**Tempo and Performance Markings:**

- Tempo:  $\text{♩} = 96$
- Section: **ACCEL** (starting in measure 6)
- Dynamic markings: *sfz*, *sempre*, *p*, *mf*
- Rehearsal marks: 463, 464, 465, 466

**Structural Changes:**

- Measures 4 and 5 are in 4/4 time.
- Measure 6 begins an accelerated section, marked with a large **3/4** time signature.

Figure 9

This musical score, labeled "Figure 9", is a page from a larger work, numbered 26 in the top right corner. It features a full orchestral arrangement. The woodwind section includes Flutes 1 and 2, Oboes 1 and 2, Clarinets 1 and 2, Bassoon 1, Bassoon 2, Horns 1, 2, 3, and 4, Trumpets, Trombones 1 and 2, and Tuba. The string section consists of Violins 1 and 2, Viola, Violoncello (Vc), and Contrabass (Cb). The keyboard and percussion sections include Piano (Pn) and Percussion (Per). The score is written in a key signature of one sharp (F#) and a 2/4 time signature. A dynamic marking of *ff* (fortissimo) is present in the Clarinet 1 part, with the instruction "Tutta Forza" written below it. A circled number "3" is placed above the first measure of the Flute 1 part, with a downward-pointing arrow. The Trombone 1 and 2 parts include the instruction "SLOW GLISS TO (E)". The Tuba part includes the instruction "GRAND GLISS". The Percussion part includes a circled number "7" and a dynamic marking of *f*. The Violin 1 part includes the instruction "short". The Violoncello and Contrabass parts include the instruction "SLOW GLISS TO (E)". The score is densely notated with various musical symbols, including notes, rests, slurs, and articulation marks.



Despite the inflections and deviations from the basic material it was hoped that the listener would have a familiarity with the scale by the end of the piece, if only at a sub-conscious level.

### **Structural Features of *Incantation***

If the concept of a 'macro-scale', as outlined above, is one which encourages an image of a unified structure then the structural techniques employed do much to contradict this: *Incantation* proceeds largely as a mosaic of related but diverse fragments of music. Each of the new, and often brief ideas, revisits similar basic concepts (perhaps the 'macro-scale') or alludes to other ideas in the work (for example bar 21 is related to the material in bar 213). A degree of consistency is created by the prevalence of two of these ideas or themes and their relatively systematic distribution throughout the piece. Figure 10 shows the position of each type within the structure. (An \* is used to denote other types of music much of which is of secondary importance). The **A** material is characterized by a tutti chord followed by a rhythmic discourse on a tone or semitone diad close to the f# tonal centre. The **B** material is characterised by wide intervals (tritone, ninth ...) and a clearly defined melodic contour. During the course of the piece **A** type music is repeated or, for example, is transformed into the melodic material used from bar 86 onwards. **B** type music is gradually extended during the piece beginning as a one bar fragment at bar 6 and extending to a 57 bar melody at 270. The two types of music serve different functions: **A** is a punctuating device which expands vertically into cluster-like material, and **B** is wide ranging, and expands linearly and rhythmically each time with varied accompaniments.

Figure 10 Incantation Structure

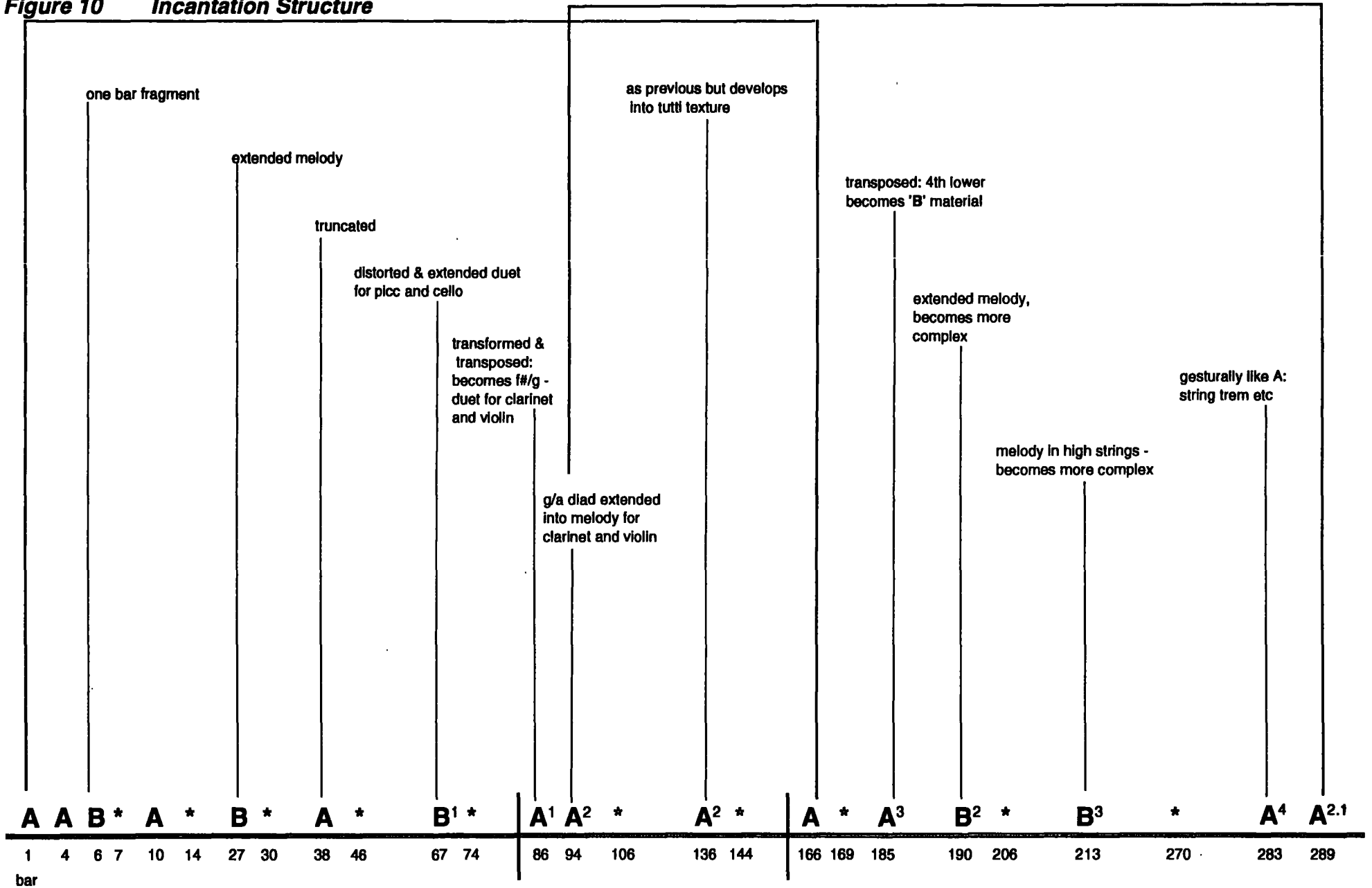

The music between the occurrences of **A** and **B**, denoted \* in Figure 10, can be divided into seven types:

**C** - low cluster counterpoint

**D** - rising 3 note motif (tritone based)

**E** - static harmony

**Z** - textural counterpoint

**Y** - textural counterpoint - sustained

**X** - aleatoric textures

**W** - aleatoric punctuation

Types **Z**, **Y**, **X** & **W** are unmeasured, unsynchronised 'aleatoric' musics and are mostly used to create focal points or brief moments of climax during the piece (particularly at bars 162, 213 and 271). Whilst I have chosen to differentiate between the 'composed' music and the aleatoric writing there are instances in the piece where this distinction is blurred. One of the many examples is the 'composed' music at the beginning of the piece which resembles, rhythmically and texturally, the unsynchronised nature of the aleatoric sections. Other instances in the work combine the aleatoric and 'composed' music. Appendix Two is a reduction of the entire motivic material of *Incantation* and includes, amongst other things the distribution of the elements listed above.

At another level the work can be viewed as a simple tripartite form (fast, slow, fast) delineated largely by tempo, orchestration and pacing. The first section features rapid cross cutting between the various ideas and has brief climactic moments at bar 56, and at bar 83. The middle section (bar 85 - 163) has a slower harmonic rhythm, restricted harmonic palette and features chamber groupings such as violin and clarinet; oboe and piccolo, and strings (harmonics). The last section includes a repeat of the opening idea and a major discourse on B type material. Climax passages in this section are at 207 ff, 213, 271 and 283. One might also see an arch-like shape in the work with its 'highest note possible' section at the centre of the piece and the focus on middle registers in the opening and closing passages.

### **Orchestration Techniques**

The resources available were foremost in guiding the instrumentation of *Incantation*. The absence of timpani and the restrictions in the number of brass, strings and doubling woodwind were amongst the initial quandaries. In the case of the timpani this was a positive factor for I felt that, like some other percussion instruments such as snare drums, they dominate and stylize the orchestral sound in a particular way which was alien to the soundworld I was creating.

In all other respects the orchestration of *Incantation* is quite traditional. There is little in the way of special effects (except 'highest note possible', detuned 'cellos, and some percussion effects), the work focussed instead on fundamental orchestration techniques: doublings, octave doublings, and homogenous scoring (woodwind, brass, string families). This approach was the result not of being

unwilling to experiment but of desiring to find the best method of allowing the inherent resonances and timbres of the music to speak for themselves. For example homogenous scoring is used to blur already 'hazy' pitch and rhythmical material (for example the strings in the opening bars) or to clarify the registral and intervallic qualities of some of the harmonies ( for example in bar 42 the brass identify a contrasting harmonic area to the strings). The orchestration is also driven by spatial possibilities of the orchestra in performance and, to a lesser extent the visual qualities of the music on the score.

At a fundamental level the orchestration techniques employed were aimed at illuminating all thematic and gesturally important material in the piece. Whilst it is impossible to isolate the orchestration from the basic process of composition the approach taken was to ensure that a clear orchestral texture was achieved in what is otherwise a dense and complex musical fabric.

## **Calypso's Song to Ulysses (1987/88)**

for soprano, soprano saxophone, alto flute, viola, percussion,  
double bass

(duration 12')

*First performance:* *SPNM Composers' Workshop. University of York.  
New Chamber Players, conductor Philip Cashian  
February 1988*

*other performances :* *University of Durham  
New Music Group  
May 1988*

*Guildhall School of Music and Drama  
Student ensemble  
June 1993*

### **Introduction**

The fact that this piece has not yet received a professional performance is, I feel, a reflection on the unusual instrumentation it employs and the inherent difficulties in rehearsing it. Indeed if I were forced to select a seminal work in my portfolio it is likely that this piece would be my first choice. Within this context its importance is as a crossing point between what I now regard as formative pieces (illustrated in the language and soundworlds of *Recycle and Incantation*), and works of a freer, more individualistic nature which were written after it. Contained within it are many pointers which suggest harmonic, melodic and stylistic fingerprints which have developed in later pieces, but it also contains music which demonstrates the peak of my previous interest in rhythmic and contrapuntal complexity (for its own sake) and passages of relatively fast harmonic rhythm. Despite my intention that the work should turn a 'creative

corner' it proved impossible to shake off completely those compositional elements which had interested me up to that point.

The concept for the piece stemmed from the language (and images) conjured up in Adrian Mitchell's poem *Calypso's Song to Ulysses* from the collection *Ride the Nightmare*. These sensual and erotic images immediately suggested the soundworld of the piece and the instrumentation which was best suited. As well as having clear links to a jazz ensemble (soprano saxophone, vibraphone, double bass) the instrumentation has many other qualities which are exploited in the work: for example, the alto flute and viola are used as mellow inner voices because of their similar timbral qualities, and the soprano saxophone and solo voice are used as an important pairing (representing the two bodies suggested in the text). Furthermore all of the instruments are capable of blending together in the octave above middle C, where a considerable amount of the pitch material is heard, without any one instrument dominating the general balance of the group.

### **Structure**

The structure of *Calypso's Song to Ulysses* is governed largely by the pacing and content of the text. The table in Figure 11 below outlines the main structural divisions and identifies the instrumentation and materials in each section.

**Figure 11**

<u>bar</u>	<u>section</u>	<u>instrumentation / material</u>
1	<b>Introduction</b>	saxophone: melody
16	<b>verse one</b>	viola/flute: G - cluster harmony
34		vibraphone: diads
49	<b>bridge</b>	saxophone: solo melody chordal accompaniment
58	<b>verse two</b>	viola/flute: flute of melodic importance
71		tutti texture
90	<b>bridge</b>	tutti texture
96	<b>verse three</b>	tutti texture
108		flute/viola/marimba calypso tempo & rhythmic units
110		sax & voice shadow each other
130	<b>bridge</b>	tutti: becomes reprise of the ideas from the end of the introduction
146	<b>verse four</b>	viola & bass related to each other vibraphone: diads
160		flute joins chordal material
171		tutti: calypso-type music established
187	<b>coda</b>	calypso-type music interrupted solo sax material related to the opening



It can be seen how the structure of the poem is clearly delineated in the instrumentation and material of each section. (In a number of cases each sentence within a stanza is given different treatment.) Of particular importance is the role of the saxophone: it is often a solo voice, used for example in the introduction, and bridge passages to set the mood of a given section. Other instruments as mentioned above perform textural functions, particularly the viola, vibraphone and alto flute.

Before discussing the more intricate structural details of the piece it might be helpful to highlight the relationship between the text and the music, and to give examples of the word painting used in the music.

Two important elements in the piece grow out of the text and its particular legendary associations: firstly a dance-like melody/rhythmic idea (a calypso) which permeates almost all sections of the piece (this is discussed later) and secondly a chord, related to the calypso idea, which is derived from Wagner's Tristan chord.

The use of the Tristan chord, with its various associations, was suggested by the legend: Calypso was a sorceress who fell in love with Ulysses on his journey home from the battle of Troy and attempted to bewitch him into staying with her. Only the first chord of the Tristan progression is used, suggesting a parody of the reciprocal love of Tristan and Isolde. It appears in a distorted form as cadence points half way through the piece and at the very end.

On a smaller scale much of the music relates very closely to the suggestions and moods created by the text, Calypso's luring and bewitching spell being represented by the melodic line 'spun' by the saxophone at the opening, and the cymbals (played with brushes) creating a sensuous shimmering texture.

Furthermore the poem was particularly well suited to word painting, some examples of which are detailed in the table below (Figure 12).

**Figure 12**

<i>words</i>	<i>bar</i>	<i>characteristic</i>
<i>tender feathers</i>	20	flute + viola (pp) flutter tonguing/trills
<i>soar</i>	29	register, sweeping lines: alto flute, sax
<i>feet are two comedians</i>	34	vib: diads, quirky character
<i>jokes</i>	39	quirky/humorous lines
<i>wheels / revolving</i>	71	pitch cells, repeated cyclic material, cymbals
<i>rhythm/heartbeat</i>	96	mechanical, rhythmic material
<i>rise and fall</i>	156	contour of the vocal line
<i>two loving bodies</i>	160	two duets (flute/sax, viola/bass)

Working in parallel with these techniques are broader scale structural considerations, the most important of which is the formation of the calypso-like dance material.

The diagram in Figure 13 illustrates the gradual formation of the dance-like material and shows how, for example, the E pitch centre and small fragments of the melody are established from the outset (1A, 1B) and later passages relate to the profile of the 'calypso' (2A, 2B, 3B). This gradual process of assimilation is completed by bar 172 though the bass and soprano do not comply with the style or pitch material of the 'calypso'. It is not until bar 187 that the process is complete.

As the diagram shows in example 4A the 'calypso' is also used to create harmonic material, and through distortion becomes the Tristan chord which is used at key moments.

Structural unity is achieved at a more local level by a process of 'suggestion and realisation' : the essence of a musical idea is hinted at and several bars later becomes the focus of the material. This procedure is used in many of my pieces and is an attempt at involving the listeners' short term memory in the cognitive process of understanding the music. The procedure might thus be regarded as a form of *déjà vu*.

Examples of this are shown in Figure 14. Example 1 illustrates the displaced scalar elements hidden within the saxophone line at the opening which lead to a scalar passage at bar 15. Example 2 shows the chordal material at bar 8 and the corresponding cluster material in bars 16 - 20.

Figure 13

1A SAX ① 2 3

2A SAX ④ 5 profile

2B perc ⑫ profile

3A perc ⑬ pitches

3B ⑭ flute pitch + profile

4A Ω SAX

HARMONIC EXTRACTION b. 56

FLUTE VIB

VIOLA

BASS

5A FLUTE ⑩⑧

CONTOUR + GESTURE

6A ⑬⑥ SAX/FLUTE

[WAYWARD BASS + VIOLA]

BREAKS DOWN...

7A ⑬④ DISTORTION OF CALYPSO HARMONY - 4ths

8A ⑬②

[MASKED BY SAX + WAYWARD ACCOMPANIMENT]

Figure 14

**1** SAX

BMP

① ④ ⑨ ⑩ ⑪ ⑫ ⑮

**2** HARMONIC MATERIAL  
BASS 8

PITCH MATERIAL  
BASS 16-20

A C D E F B

One might also argue that the rhythmic material starting at bar 96 follows a similar principle; example 3 shows the rhythm of the first few bars of this section and identifies the basic rhythmic units. These form the following pattern:

bar 96

a b c d a b c d a b e a f a b c d a f e a b c d f a b c d a b e a c d a a

These rhythmic, structural and harmonic processes help create a tightly organised piece and, although such restrictions could be regarded as contradicting the fleeting, carefree imagery of the text, the choice of ensemble and inclusion of the calypso-like dance music restores the balance.

This is by far the most powerful  
 piece of my work. It has compositional clarity  
 + puts up possibilities at all levels of operation -  
 you tend to stick with basic ideas  
 - something needs to happen + emerge.

## **Making a Song and Dance... (1989)**

for violin, 'cello, clarinet and piano

(duration: 11')

*Commissioned by the 1989 Sonorities Festival of 20th Century Music*

*First performance: 1989 Sonorities Festival of 20th Century Music  
 Harty Room, Belfast  
 Sequenza*

*other performances & recordings:*

*Scandinavian tour  
 Capricorn  
 February 1990  
 Broadcast: Danish National Radio*

*Sequenza  
 Neuma CD Label  
 to be released in 1994*

### **Introduction**

This piece is a pivotal work in my folio. Firstly it was written when I had returned to Ireland and was looking for new directions to explore in my composition. Secondly, the pieces which I had written up to this point had been concerned mainly with manipulating systems, formulae and structures; this piece was to provide a departure from these processes by allowing a more intuitive approach. (As it happened the use of processes was integral to the early part of the pre-compositional work and defined the paths along which *Making a Song and Dance...* could develop). To effect such a break with the complexities of earlier

pieces a strong external stimulus was used. The folksong, *The Lasses of Donaghadee* provided this and at the same time suggested a direction in which subsequent pieces might develop.

The exact origin of *The Lasses of Donaghadee* is unknown but it is suspected to be a folksong indigenous to North Co. Down. Certainly it bears a number of the important hallmarks characteristic of traditional Irish music. Not least of these is its particular modal progressions and 'slow air' qualities. Such a piece would be played in 'unison' by instruments such as violins, tin whistles and uilleann-pipes with considerable embellishment or ornamentation. The piece originally came to my attention as a song for soprano and piano by Hamilton Harty in which the melody was harmonized with folk-like progressions.

For me the original melody (shown in Figure 15) offered a new and potentially fertile area to explore, namely conjunct melodic lines and simple, consonant intervals, but it was not until pieces such as *A Slow Dance*, three years later, that I was utilising this type of simple material to its full potential.

**Figure 15**



**My initial concerns at the outset of writing the piece were as follows:**

- to reduce the rhythmic and textural complexity of my music
- to broaden my harmonic and melodic palette using the folksong material
- to explore fully simple rhythmic devices such as canon, isorhythm and rhythmic distortion
- to achieve greater clarity of structure than in previous works through the controlled juxtaposition of repeated and developed material

To what extent these objectives are totally met in this piece is debatable but there is no doubt that they are signposts pointing towards particular developments in my compositional language which evolved in later works and are still influential to a large extent.

### **Compositional Processes**

The transformation of the original melody was the starting point in the composition process. As Figure 16 shows, the initial notes of the melody formed the basis of a pitch matrix which contains all transpositions and inversions of the melody. Without doubt the most intriguing qualities of this matrix are the unusual harmonic and melodic possibilities which result from the repetition of pitches in

the original melody and the non-chromatic row which is presented as the 'prime'.

**Figure 15**

LASSES OF DONAGHADEE

The image displays five staves of musical notation for the piece 'LASSES OF DONAGHADEE'. Each staff begins with a treble clef and a key signature of one sharp (F#). The notation consists of a sequence of notes and rests, with some notes beamed together. The first staff contains 14 notes, the second 14 notes, the third 14 notes, the fourth 14 notes, and the fifth 14 notes. The notes are primarily eighth and quarter notes, with some half notes and rests. The overall melody is characterized by a mix of chromatic and non-chromatic intervals.

In other compositions where such a grid was used (not included in this folio), it would have been explored by some rigorous process such as zig-zagging through the grid (for example reading tetra-chords (left, down, left, down) as shown below).

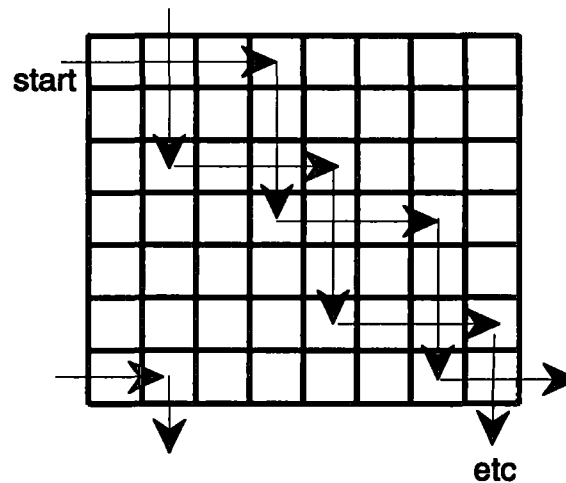

Such processes implied that the grid was not square but in fact a spherical object which allowed continuous passage around the material. The results from these explorations were most often used without correction or intervention.

In the case of *Making a Song and Dance...* the pitch material was to be treated freely, as something to 'dip into' to generate pitch material at key points in the work. Examples of this include the opening piano idea which identifies the main pitches of the original melody, the descending lines at bar 118, and the final passage of the piece (bar 261 ff). Furthermore the modal matrix itself became a subject for further pitch transformation and produced the pitch set shown in Figure 17. The example also identifies the main characteristics of the pitch set which had a considerable influence on the harmonic language of the piece.

4

PITCH MATRIX II - LASSES OF DONAGHADEE

The musical score is written on a system of five staves. The top two staves are for Violin and Piano (RH). The next two staves are for Clarinet and Piano (LH). The fifth staff is empty. The score begins with a key signature of one flat (B-flat) and a common time signature. The Violin part starts with a melodic line, with a handwritten annotation 'b.20' above the first measure. The Piano (RH) part provides harmonic accompaniment, with a handwritten annotation 'b.1' above the first measure. The Piano (LH) part also provides accompaniment, with a handwritten annotation 'b.1' above the first measure. The Clarinet part has a melodic line, with a handwritten annotation 'b.10' above the first measure. The Piano (LH) part has a melodic line, with a handwritten annotation 'b.6' above the first measure. The score continues for several measures, showing the interaction between the instruments. The notation includes notes, rests, and accidentals. The overall structure is a pitch matrix, where the instruments play different parts of a single melodic line.

A series of ten empty musical staves, arranged in two groups of five. These staves are not filled with any musical notation.

PITCH MATRIX OF LASSES OF DONAGLIANE

FIGURE 16

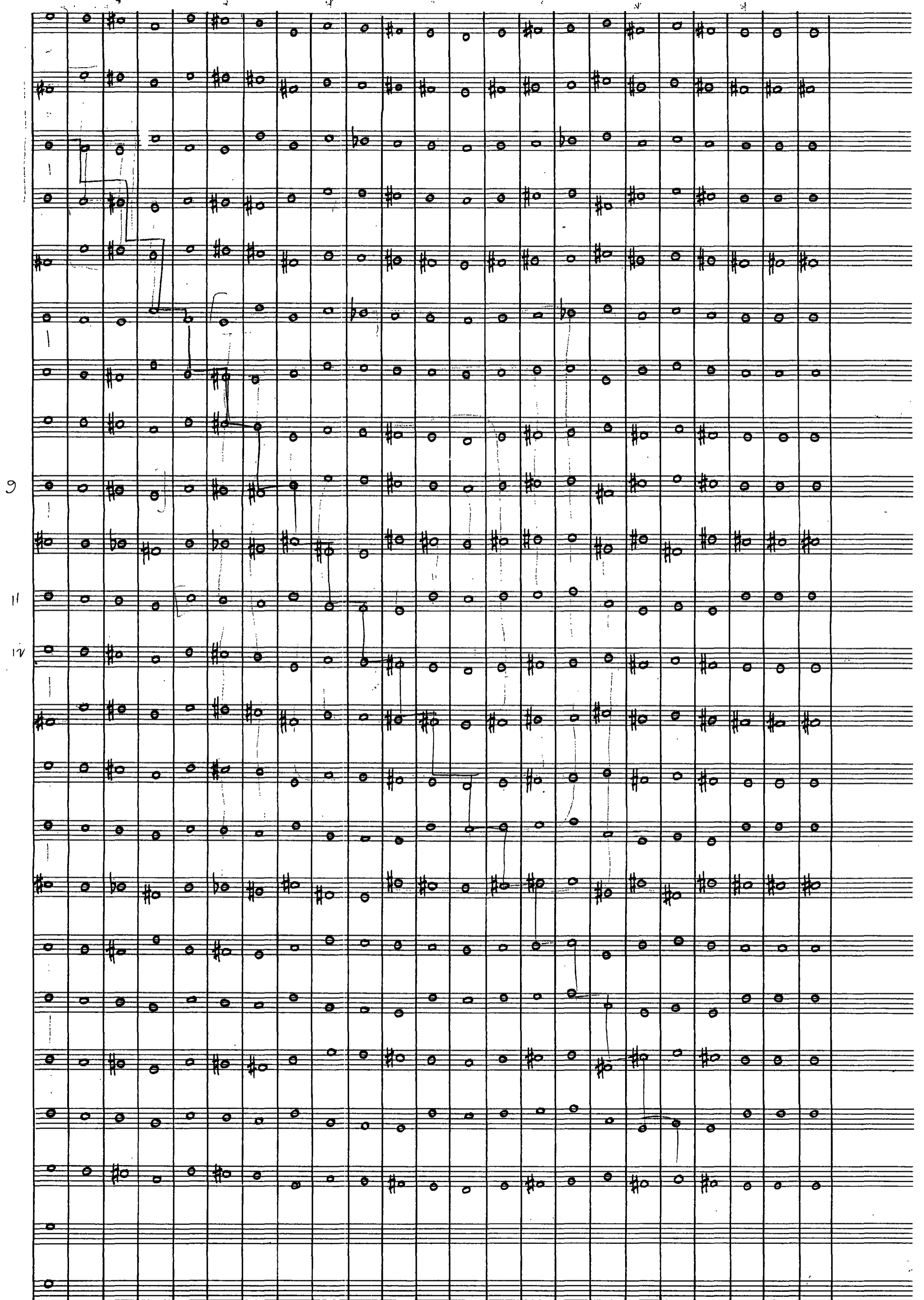

Figure 17 shows the new pitch set and its associated transpositions. This matrix was used to generate much of the music in other passages. For example the opening section of the piece takes its material from the matrix (as identified in the example) with each instrument playing independent rows of the matrix. Again this matrix was treated freely with some notes being adjusted from the pitches defined in the row according to my desires, or entire sections of selected pitches omitted for the same reasons. The freedom to call upon any given system or matrix, and to use these as compositional tools rather than as dogmas to follow was, to say the least, liberating. In this way the musical 'cement' is provided not by the system itself but by an inner 'ear' casting around for objects drawn from or modifying material from common sources (eg the pitch grids) to enlighten the compositional procedure.

To some extent the rhythmic patterns of *Making a Song and Dance . . .* evolve from a similar process of extraction from the original folksong: converting the rhythms of the melody to quavers and semiquavers produces the following line. (Figure 18 also shows how this relates to the opening gesture of the piece.)

**Figure 18**

RHYTHMIC MATERIAL OF THE 'LASSES OF DONAGHADEE' [TRANSFORMED]

opening gesture [pno]

The diagram also shows how the first rhythmic gesture of the piece may be derived from this material. All simple semi-quaver passages in the piece have their origins in the above rhythmic strand.

From this rhythmic canons were created: for example the clarinet line at bar 10 is a canon of the piano line at the opening (the first unit of the canon is omitted); similarly the violin line at bar 20 is another canonic strand in this sequence. Another example may be found at bar 34 where the rhythmic unison, established in the opening bars, drifts by one semi-quaver in bar 37. Rhythmic transformation is also used in the passage at bar 188 where the various lines are derived by simultaneous augmentation of the violin line. The augmentation process is also applied chronologically: each successive section using longer rhythmic units and decreasing in tempo.

### **Other Melodic and Harmonic Considerations**

The general descending contour of the opening phrase of the folksong was used as a model for much of the melodic material in *Making a Song and Dance...* This is utilized over short gestures and over longer passages of music such as the opening which passes from the highest register of the piano to the middle resonant register. This is achieved by a quasi-random process of dropping pitches through octave displacement over a given number of bars. The clearest example of descending lines is in the passage from letter G to letter K where each short section moves from one register to another; similarly the lines at bar 255 follow this contour.

Other important influences on the pitch material of this piece were the gestural and technical qualities of the instruments. In earlier works the results from a particular process were inflicted on the instrumental lines, often with less regard for the feasibility of these gestures on the instruments than for the details of the pitch material. In this case the collective timbre of the ensemble and the resonant possibilities of each instrument were prominent considerations in the early composition process and, as a result, helped narrow the search through materials such as the grids when developing ideas. An example of this would be the passage at letter **A**, which was conceived with the open 5ths of violin line in mind. These were included to ensure that a resonance of the violin cut through the dense harmonic blocks of the ensemble.

### **Structure**

The title played a major part in the development and implementation of the main musical ideas of *Making a Song and Dance...*. The choice of the title is related to my predilection for lyricism (*song*) and stylized rhythmic gestures (*dance*), and the possible processes through which these types of music can be created and cross-fertilized. Taking an overview of the piece it is perhaps best regarded as a mosaic of dances, songs and hybrid types of music. Closer examination reveals a number of important relationships across the piece. For example the rhythmic material at bar 34 can be related gesturally to the music preceding it and following it (as shown in Figure 19).



Figure 19

b34 Tutti



violin b20



b85 v'cello ♩ = 69



Furthermore the influence of this music can be observed in other passages of the work:

- b 34 original
- b 69 modified to 6/16
- b 99 developed from b85
- b 109 developed from b99
- b 193 long notes added
- b 236 close to original

Other examples of links throughout the piece include:

opening -

related to b47, b171 ( the latter might be regarded as a recapitulation)

b44- (semiquavers)

related to b 246

b163 (piano arpeggio)

related to b 207 - piano arpeggios

As stated at the opening of the commentary *Making A Song and Dance...* marks a significant development in my compositional language: namely the use of simple harmonic materials (especially at the end of the work). Although the work might be viewed as being over-endowed with ideas (a characteristic which is addressed in subsequent pieces) its success is linked to the strength of the pitch and rhythmic material derived from the folksong melody.

Not at all!

agreed ✓

# **Voyager** (1990)

for mixed ensemble, live electronics, tape and slide projection  
(duration: 10'22")

*Commissioned by the Arts Council of Northern Ireland for the 1989/1990 Young Arts Festival*

*First performance: Lurgan Town Hall, Co Armagh  
pupils from Portadown Grammar School and St Patrick's  
Grammar School, Lurgan  
January 1990*

*Subsequent performances: Accents Festival in Dublin  
April 1990  
Haenjo ensemble*

*Armagh Planetarium  
using Lasers and multiple slide projection.*

## **Introduction**

This work was commissioned specially for an education project in schools in Northern Ireland in 1989/90 and was targeted at GCSE students of a relatively advanced instrumental standard. My aim was to introduce electro-acoustic music and new performance methods to the young musicians and above all to bring the concept of timbre to their attention.

The inspiration for the work stemmed from a set of photographs published in many of the broadsheet newspapers in August 1989 which showed high definition images of Saturn taken by the spacecraft Voyager II on its journey

through the solar system. These photographs, which were unprecedented in terms of detail and quality, were part of a series of images transmitted by both of the Voyager spacecraft since their launch in the mid 1980s. I felt that these images would prove to be a very powerful stimulus for the musicians and the audience, and would also help unite in some programmatic way the electronic and instrumental soundworlds.

The challenge of writing music for younger musicians is considerable. The piece had to be written for pupils of a varied standard of instrumental proficiency and unspecified resources and had to be prepared with a minimum of rehearsal time (6 hours per performance had been allocated). Because of these constraints I resorted to using a simple score which allowed for most of the usual assortment of school instruments (flutes, clarinets, strings, piano/keyboard, brass, percussion) and a method of notation which, because of its reliance on improvisation techniques, provided scope for the variety of technical abilities. In this context performers could be asked to apply their skills to the manipulation of one or more of the parameters of pitch, rhythm or gesture to contribute to the performance at a level appropriate to their ability, within a controlled environment.

*Yes!  
80s!*

This immediately leads to questions about the validity of such techniques in the 1990s, which are largely associated with the 1960s music by composers such as Lutoslawski and Penderecki, and about the control which the composer relinquishes over the music in the process. In the context of this piece and my music generally it can be justified: for *Voyager* it provided the most flexible line to take and proved to be stretching mentally and musically for the performers; in my music as a whole it represents one extreme in the use of a compositional technique (controlled aleatoricism) which features in a limited way in many

Need to argue this one

pieces. Going further one can justify such freedom as a valid action in a compositional language such as mine, given that the influence of random patterns and the random results that can arise from working in the electro-acoustic medium play a large part in guiding my music.

### **Compositional processes and procedures**

The compositional procedure in a work such as this is governed considerably by the objectives, context and resources of the project. (One might argue that these considerations should play little part in the formulation of a composition, where, ideally at least, the composer should be guided only by a creative vision. Whilst techniques such as these might not be strikingly original they do nevertheless demonstrate some of the flexible skills which today's composer needs to adopt as a professional artist working in the field of new music.) Early in the process of planning this work I was keen to define the role that the musicians would take in the piece and to create tasks which would challenge them in specific ways. Six basic tasks or skills were identified which would be used to form the backbone of the piece:

- exploration of unconventional instrumental sounds (extended instrumental techniques - self discovery)
- rhythmic improvisation with a given pitch set
- melodic/gestural improvisation with given durations
- timbral exploration

- instrumentation/orchestration tasks
- reacting to a variety of stimuli - visual (slides), aural (tape, fellow musicians) notation (unconventional score instructions)

In terms of the folio this piece represents one extreme in my method of organizing musical materials and, despite its simplicity, illustrates some of the textural and harmonic fingerprints of my musical language. The electronic sounds used in the piece were created in a small studio using basic MIDI equipment (sequencer and two synthesisers) and three reel-to-reel tape recorders.

After sifting through the entire collection of images from the Voyager spacecraft (more than three hundred slides were made available to me by the Armagh Planetarium), a visual sequence was created from eighty four of these slides. The structure of this was governed not by the chronology of the photographs (following the path that the spacecraft took), nor by their astronomical qualities, but by the succession of colours and shapes that could be created. In general the sequence progresses from vibrant, fiery-red slides through to black and white images of close-up landscapes and eclipse images (Colour photographs from this sequence are shown in Appendix Three).

In addition to this visual process the idea of voyaging or journeying was used as a structural plan for the piece. In particular the voyage of the spacecraft from the polluted environs of the earth to deep, as yet, unpolluted space was mirrored in

the general pitch and harmonic progression where the chromatic cluster-like material near the opening of *Voyager* (01'17") gradually becomes static, sparse and consonant material towards the middle section of the piece. This idea is extended to include a broad shift in register during the piece from high noise-like timbres at the opening to a low b flat pitch at the end of the work (08'23"). One might regard these processes collectively as a passage down through a single complex sound spectrum from higher, dissonant 'partials', through harmonies of decreasing dissonance, to a 'fundamental'. The 'fundamental' in this case is itself a complex timbre and during the final moments of the work its inner detail is revealed, starting with timbres and noise-like material in the higher register. Thus the registral and pitch process could be regarded as beginning again, in a procedure which is similar to the behaviour of fractal images.

Other journeys include a progression from active, disjunct and aggressive music at the opening to consonant material which, given the scalar presentation of the pitch material at 06'30", is likely to be conjunct and melodious. As suggested above the harmonic language of the piece is based on a simple registral and harmonic progression to a 'fundamental' and then to a series of noise-like timbres. Within this are a number of 'sub-progressions'. For example the pitch material of the instrumental parts at 01'17", based on the semitone intervals of the tape chord, gradually ascends, both by octave displacement and by transposition to arrive at the same chord again before the next section at 2'46". The middle tape section, which explores two diads a semitone apart, becomes the pivot for the previous cluster material and the pitch material of the next section (which has its origin in the overtone series and in a progression inspired by *Neptune* from Holst's Planet Suite).

At this early stage of composition the challenge of harnessing these structural ideas to improvisation techniques was considerably demanding. In essence two time scales existed; firstly the scale which is suggested by the simple progression from noise to consonance to noise, and secondly the time necessary for many of the improvisation techniques to unfold and create their desired effects. In the latter case it was necessary to judge and control these processes quite carefully given the static nature of much aleatoric music. The tape plays an important role in controlling this process: on one hand it provides aural cues suggesting gestures, registers and timbres for the improvisation techniques, and creates a backcloth against which the sounds may be played, and on the other hand it delineates the freedom of the improvisation by providing fixed timings which control the duration and overall structure of the piece.

In most cases the improvisation skills are concerned with manipulating written pitch material with the performers having a degree of freedom over rhythmic interpretation. Feeding into this is guidance from written instructions in the parts for example at 1'17" :

Create fast, aggressive and intricate musical gestures from the pitch material provided. React to the tape sounds, the gestures played by other members of the ensemble and any other indications on the score . . .

and other parameters such as 'trill percentage' which instructs the players to trill a certain percentage of the events or gestures in a repeated section.

Built into the aleatoric passages are controls over pitch material (for example at 1'17") which ensure that there is continuity (much of the pitch material of any section is common to all instruments) and variety (the ordering of the pitches is



different for each instrument and in a number of instances some parts have pitches that are unique to the texture at that point).

Other passages require the performers to improvise pitches in a decelerating pointillistic texture. In most cases performers (young or old) found decisions over pitch material harder than rhythmic manipulation.

The improvisatory passage which begins at 6'30" and extends for a further two minutes is perhaps the most difficult section of the piece to control (both from my position as a composer and from the performers' position as contributors to the development of the material); firstly, it is difficult to sustain this material for such a length of time; secondly, there is little in the way of tape cues to guide the (suggested) lyrical melodic lines; and thirdly, the score also requires the performers to build the material to a climax at 8'23" (without the assistance of tape). It was hoped that the performers would find a method of extemporizing on this material and a way of creating a climax at 8'23" (thus developing some understanding of the processes at work in creating a musical climax in other contexts) by crescendo, increased activity and possibly a gradual shift in registral focus of their improvisation.

### **Electro-acoustic Sounds**

The tape sounds for *Voyager* were created with modest studio resources: 3 analogue tape recorders, *Yamaha SPX90II*, *Yamaha DX5 synthesiser*, *Roland D110 module*, *Yamaha TX802 module*, and Mark of the Unicorn's *Performer* software. Many of the sounds are MIDI sequenced timbres from voices modified on the synthesiser and associated modules. Others were created from analogue tape techniques, for example splicing and labyrinth techniques. The latter

process involved running a tape across all three tape recorders and recording sound on the first machine which would be replayed on the second and third machines. The audio signal can then be adjusted (or coloured with equalisation) on the mixing desk and fed back into the system. The process usually produces a slowly disintegrating (and increasingly noise-like) timbre. In *Voyager* this was used to create the final sound of the piece. The source sound (an arpeggio of bell timbres) was played backwards and fed into the labyrinth. The finished processed tape, played backwards, begins with the transformation (a convoluted noise-like timbre) which gradually becomes the original timbre (in the correct direction). In the piece the sound is faded out just before it reveals its identity. The diagram below shows the configuration of the tape machines.

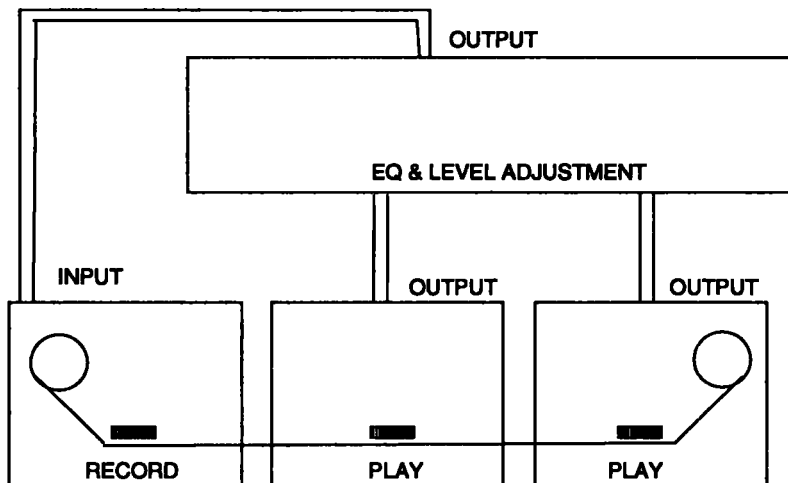

Other sounds were derived from unusual sources. For example, the opening noise-like timbre was created from feedback achieved by connecting the output of a *Yamaha SPX90II* (set to a flange preset) to its own input, via a mixer. Varying the equalisation and levels at the desk allowed rich and dynamic spectra to be produced. Also, the textural sound used at 8'30" was created from piano

attacks which were fed through noise gates (with a short attack and decay rates) and onto each track of the two track tape recorders. This was then mixed directly into the final version of the piece.

Despite its simplicity in terms of the concept, the materials and techniques employed, and the score, *Voyager* is quite an important work and has influenced, above all, the structure and pacing of more recent compositions. To date it has remained my most performed composition.

**Perichoresis****(1990)**

for wind quintet

in three movements

(duration: 12')

*Commissioned for the Nash Ensemble by the Belfast Music Society with funds provided by the Arts Council of Northern Ireland to celebrate the 70th year of the Society.*

*first performance: University of Ulster at Coleraine  
Nash Ensemble  
10 October 1990*

*Broadcasts & recordings: Nash Ensemble  
BBC Radio 3  
26 April 1991*

*Belfast Wind Quintet  
Neuma CD label  
To be released in 1994*

**Introduction**

*Perichoresis* is in one respect unique within the context of my folio, being the only work which was written with previous experience of a particular medium or resources. All other pieces are the fruits of first experiments with their ensembles or instrumentations. In this case an earlier Wind Quintet *In a Roundabout Way* (1987) was a valuable springboard for many technical and timbral considerations in *Perichoresis*.

Many of the noteworthy points of this piece stem from the possible interpretations of the title. Indeed it is this which guided the planning of the dramatic structure and musical ideas of the work. Amongst the various definitions of *Perichoresis*

are the following: going around, rotating, transferring to, to come to in succession. Greek words which may be extracted from it include: *choreutes* (to dance), *chori* (to tear asunder, wrench apart) and *choragus* (the leader of the chorus in Greek drama). These ideas were applied, often through underlying dramatic devices, to various musical parameters and processes. One which is particularly important is the role played by the oboe within the ensemble. Whereas most wind quintets might explore the sounds and timbres of a balanced ensemble, this piece presents the oboe as a solo or principle voice (standing at the centre of the group) with the other instruments accompanying or conversing with it. In this way it can lead the ensemble (acting as *choragus*) and control the dissemination of the musical material. Many of the ideas derived from the title are suggestive of ritual and are supported by the presence of other elements such as the *crotales*. Feeding into this are other words such as *Peri*, a word in its own right, which means one of a race of beautiful supernatural beings in Persian folklore and is personified here by the oboe.

The first movement demonstrates some of these features in operation.

bar 1	solo oboe	clarinet resonances
bar 4	ob / cl	clarinet is given material
bar 13	ob / cl / fl	flute resonances
bar 18	ob / cl / fl	flute is given material
bar 31	ob / cl / fl	each play relatively independent lines
bar 35	tutti	bassoon & horn come to life in a similar rhythmic and durational process as the clarinet and flute

bar 37 ff	tutti	oboe sets the dramatic pacing of the music (rhythmic complexity)
bar 59	tutti	all instruments come together in trills etc
bar 73	tutti	oboe instrumental in the demise of clarinet flute and horn material

There are instances where the role of the oboe is challenged. The central passage of the second movement shows this quite clearly. After the opening solo oboe passage a new section, which explores a wide variety of gestures, features fast figuration in the oboe line. This is triggered initially by the clarinet and leads to a high wailing passage for the oboe, which, due to the gradual proliferation of material underneath becomes engulfed into a momentary climax at bar 28. The oboe, lost in the texture at this point, becomes a secondary character for the remainder of the movement.

The definitions of the title (going around, rotating, transferring to) are reflected quite clearly in the final movement starting at figure B. The repeated aleatoric material can immediately be interpreted as embodying the rotating idea, and the development of this material as part of a process of transferring. The oboe initiates the repeated material (triggered on and off by tutti chords), and eventually this type of material is passed to the flute, and later the clarinet. By cue number 11 the horn has been drawn into the process, the bassoon triggering each cue, though by figure 12 it has no effect on the punctuation of the structure. Other examples of the influence of the title can be seen at a more local level, the orchestration at figure A of the last movement being a good example: the same

harmony is stated over the next 8 bars with the voicing of the chord being rotated amongst the instruments.

### **Other structural features**

Although *Perichoresis* uses little in the way of strict compositional procedures it did begin life from experiments in organising pitch and rhythm. In other respects it displays many features which provide unity both on a micro and macro structural level. Not least of these is the distribution of and relationship between certain harmonic areas which are frequently called upon. The two main pitch sets, a tri-chord and its extended (symmetrical) four note set, are shown, along with a series of examples from the piece, in Figure 20 below. In each case the tri-chord is present, though not always in the same inversion, and can be seen to inform both harmonic and melodic material.

Other unifying features can be seen in the broader processes occurring in each movement. All three movements begin with an initially sparse texture which becomes more dense: the first movement presents a single melodic line which is distributed eventually amongst the other instruments; the second movement, after a brief introduction, gradually embellishes the spaces between a two note rhythmic gesture on bassoon; movement three features a sparse series of chords which gradually proliferates.

Figure 20

The musical score for Figure 20 consists of several staves and annotations:

- Top Staff:** A single staff with a treble clef. It contains a sequence of notes: a quarter note, a quarter note, a quarter note, and a quarter note. Brackets above and below the notes are labeled "TONE" and "CELL" respectively.
- OBOE (BAR 1):** A staff with a treble clef. It contains a sequence of notes with slurs and accents. A bracket below the first four notes is labeled "CELL".
- [INVERSION]:** A bracket above a sequence of notes on the OBOE staff, with an arrow pointing to the notes below it.
- CROTALE PITCHES:** An arrow pointing to a sequence of notes on the OBOE staff.
- CLAR. [AFTER]:** A staff with a treble clef. It contains a sequence of notes with slurs and accents.
- Mov II - after cue 1:** A staff with a treble clef. It contains a sequence of notes with slurs and accents. Brackets below the notes are labeled "CELL".
- CLAVINET:** A staff with a treble clef. It contains a sequence of notes with slurs and accents. A bracket above the notes is labeled "CELL".
- Mov III:** A staff with a treble clef. It contains a sequence of notes with slurs and accents. A bracket below the notes is labeled "CELL".
- 62 SENZA MISURA:** A staff with a treble clef. It contains a sequence of notes with slurs and accents.



Scalar figures, producing a shift in register, occur in many places in the work: for example, the flourish at bar 65 in the first movement and its related passage in the penultimate bar of the work. Other examples are less obvious and include the slow descent in bar 28 of the second movement and the ascent of the pitch material from letter B of the last movement. In the latter case this may be traced in the upper notes of each cued section (see Figure 21).

At a more localized level continuity is created by gestural, rhythmic and harmonic events. For example there is a strong link between the clarinet / horn gestures at the end of the second movement (b 54 ff) and the opening gesture of the third movement. There is also a link between the cluster-like lines in bars 22 ff of the last movement and rhythmically punctuating lines in bars 44 and 49 of the same movement. Furthermore, the second and third movements each contain a single unifying feature: the second movement is composed around a long melodic line which eventually focuses on an F sharp (also part of the last harmonic area of the first movement), and the last movement shows a continuous preoccupation with articulation: the rhythmic material of the opening becomes the trigger for the aleatoric segments at letter B, and later becomes the faster dance-like rhythms of cue 16 (bar 29) and the repeated chords in bar 62.

**Figure 21**

PERICHORESIS [MOV III]

CUE:

1 3 4 5 6 7 8 9 10 11 12 13

### **Harmonic, melodic and gestural techniques**

As already mentioned much of the harmonic material is derived from pitch cells of three or four notes. Unlike previous works the control of the harmonic material during the composition process is extremely rigorous due to the narrow harmonic palate available. A clear example of this is the opening section which features only three pitches (excluding the crotales), extending to five by bar 29. Octave transpositions and doublings ensured that the harmonic events appeared to be constantly changing. Other techniques which help clarify the harmonic areas include the use of fixed registers for pitches within an aggregate. This can be seen in operation at bar 31 of the first movement.

Harmonic passages such as the opening of the third movement are based on tightly controlled processes. In this particular case each chord is part of a larger harmonic complex. For example the first three chords form a particular aggregate. This becomes dissected and juxtaposed with other chords from other aggregates. A similar process happens with the chords from cue 16 (bar 29) of the third movement. The diads of the two upper instruments and those of the lower (horn and bassoon) are part of a linear sequence. In most cases the same pairs of diads rarely coincide producing a wide variety of harmonic events.

Much of the general harmonic material arises from the melodic procedures being used. In many passages of the piece, where a small pitch vocabulary is used, considerable emphasis was placed on pattern, stress (note to note, phrase to phrase), and duration. This can perhaps be seen most clearly in the opening bars of the piece where the oboe line comprises a series of short gestures each varying in pitch and rhythmic emphasis. Figure 24 shows the first nine oboe gestures of the piece. It can be seen that the pitch material is gradually copied to

each register (B flat is added to the upper register in the 5th gesture, C to the lower register in the 6th gesture), and that the important emphasis on the high pitches (A & C) is replaced by an emphasis on the lower B flat by gesture 5. What is most important is that the path taken through this pitch material is different in every instance.

Figure 24

**PERICHORESIS MOV I**

[• = PASSING NOTE]    [○ = PRINCIPAL PITCH]

Other melodic devices include the process of 'shadowing' (also used in many passages of *Making a Song and Dance...* such as the violin and clarinet duet at bar 185 ). Examples in *Perichoresis* include the passage from bar 37 of the second movement where flute and clarinet are pitted against each other. Another example is at bar 50 of the third movement where the oboe and clarinet line only occasionally come into unison. This procedure could be related to the 'shadowing' effects used at the opening of the piece where the lines rarely come

Finally, one feature of this piece which deserves to be mentioned is the clear delineation of the piece into three distinct sections. Until *Perichoresis* such a division had never occurred in my music; earlier pieces explored single movement structures which were often organised around a large scale climax or series of related climaxes. Whilst the succinct and (relatively) isolated nature of these three movements is by no means ground breaking, it did point the way to the simpler structural characteristics of later pieces, most notably *A Slow Dance*, in which there is considerably less interest in goal oriented music.

## Double Escapement

(1992)

for piano and live electronics

(duration: 9'20")

*The work is due to be performed in the Autumn of 1993.*

*A MIDI sequenced 'performance' of the live piano part has been mixed with the electronic sounds to create a rehearsal version of the piece for the purposes of this submission.*

### Introduction

*Double Escapement* is the first of a cycle of pieces which explores the vast range of timbres available on the piano with the aid of electro-acoustic resources. It is envisaged that these pieces may be played separately or as a set making an extended work of approximately twenty five minutes' duration.

The basic idea for the cycle was formulated in 1987 whilst working in the Electronic Music Studios of The University of Durham on another piano and tape piece entitled *Jubilate*. At that stage I was working principally with analogue resources (eight-track, four-track, and two-track tape recorders), and with *Music11* to transform recordings of piano sounds. Despite the rich timbral qualities of many piano sounds, especially low stopped harmonics, and harmonies which excite strong sympathetic resonances, the short decay time and low dynamic levels of the short decay were found to be severely restricting. This was especially given that the rationale behind the tape sounds of *Jubilate* was the exploration and extension of piano timbres after the attacks. These shortcomings suggested that the piano attack was perhaps a sound worth

exploiting and thus the idea of a composition for piano and electronics which focussed on piano attacks became the basis of the work now in question.

Given that the manipulation of piano attacks using analogue techniques such as montage splicing is a highly time-consuming process, and that the possibilities for such manipulation using *Music11* was relatively complicated, the piece was shelved until I had access to MIDI and sampling resources.

In 1991 the project was restarted using a *Macintosh* computer, *Mark of the Unicorn - Performer*, two *Akai S1000* samplers and a *Yamaha TG77*. As the composition developed I also wrote some software utilities under *Hypercard* (running on the *Macintosh*) for manipulating pitch data; these are discussed later. Using these resources the sampled piano sounds could be controlled from the sequencer without recourse to tape recorders or multi-track recording. Furthermore it became apparent that the two samplers, connected to independent hard disk storage devices, in conjunction with *Max* program, would allow me to perform this work live in concert and to provide some basic interaction between the pianist and the technician. This has a number of benefits not least of which is the freedom from the timings of the tape and the opportunity for the performer to adjust, within reason, the tempi of some of the sections of the piece during the performance. Such decisions could be related to the acoustics of the building or to the desire of the performer to adjust the dramatic profile of any given section of the piece.

It is intended that this interaction will be exploited to a greater degree in subsequent pieces in the cycle using the commercially available *Opcode* version of *Max*, which would allow interaction between the performer and the technology via a MIDI grand piano, or using the IRCAM version of the *Max* program which allows interaction via the audio-in connection on the IRCAM Digital Signal Processor Workstation.

### **Compositional processes and procedures**

The influences on the compositional processes employed in this work stem from the tension between technical and aesthetic considerations. The timbral and gestural qualities of the sampled piano sounds and their transformations were particularly important in guiding the progress of the composition.

Beyond this, one of the over-riding considerations was to create a piece which explored the musical material within a simple structure; despite attempts to decrease the pace of my music in earlier works, for example in the opening passage of *Making a Song and Dance*, it is in this work that I feel a slower rate of change has been successfully sustained. This is in contrast to a greater degree of surface activity in the musical material. On a different level, the intense, goal-oriented gestures of previous works (which most often lead towards brief climactic moments), are replaced, in the first section of this piece, by simpler gestural events which are most notable for their contour, timing and slow evolution of pitch material. All of these features unfold within a simple bi-partite

structure which is delineated by a broad registral and dynamic change, and a sudden shift in the activity of the live piano part.

To some extent the title of *Double Escapement*, which refers to the hammer action of the piano, has a bearing on the structure in a metaphorical sense: the repeated notes of the electronic part in the first section, (performed loudly in the source recordings to create a 'bright' timbre and played back very quietly in the transformed version) could be regarded as being suppressed; these are answered, by way of a release, by the louder more aggressive material of the second section.

Other factors which influenced the compositional process were the technical restrictions of the equipment, principally in terms of the time required to load samples and programs to the *Akai S1000* during a performance (typically 20 - 30 seconds for some of the complex piano timbres), and the limited polyphony and transformation capabilities of the instrument: the sampler is limited to 4-note polyphony where each note consists of four superimposed timbres.

### **Structure**

Despite the simplicity of the overall shape of *Double Escapement* the intuitive processes at work in organising the music at a lower level are quite important, for example, the exploitation of the listeners sense of expectation. In the opening section the tape sounds unfold very slowly into a descending scale: E D C# B. Despite the very slow pace the entry of the C# at 00'52" and the B at 01'28" are an expected continuation of the initial descending shape. Another example is the plucked E pitch in the live piano part at 03'13" which pre-empt's the E pitch in the



tape part at 03'14" and anchors the harmonic suggestion of this material. The fact that this entire section focuses on the middle register of the piano (only the live piano steps beyond this register, and even then only for sporadic events) and that the rate of change of both the piano and electronics parts decreases towards the end of the section also creates a feeling of expectancy. The resolution of this is the sudden change to the second section.

The use of contrast and the control of duration could also be cited as intuitive processes. For example the crossover between the first and second sections brings together a collection of opposite states: the narrow dynamic and pitch range, slow evolution and relatively inactive piano part of the first section meet the wide dynamic range, use of high and low piano registers, harder attacks, extended writing for the live piano, and interplay and integration between the live and electronic material. With regard to the control of duration, one of the ideas behind the structure of the piece was to create a feeling of acceleration where each section (or subsection) would appear to be shorter than the previous section.

Despite the contrast between the first and second sections discussed above, continuity is created by the use of E related harmony in both sections and the development of the repeated note pattern into a high melodic line in the upper register. This melody is doubled by the repeated note samples from the first section though transposed several octaves higher. The result of this transposition is that the samples lose their original qualities and become a metallic resonance.

### Harmonic language

Two main elements were at work in guiding the harmonic language of this piece. Firstly the creation and distribution of simple harmonic areas in the work and, secondly, material derived from the program *PitchTwister* (described below) which provided additional melodic/harmonic material to connect the main harmonic areas together.

Unlike many of my previous works, this piece has an underlying harmonic progression. Although the term is not appropriate in this context it might be regarded as a type of 'Urlinie'. As the diagram in Figure 22 below shows, this outlines two interlocking tritones.

Figure 22

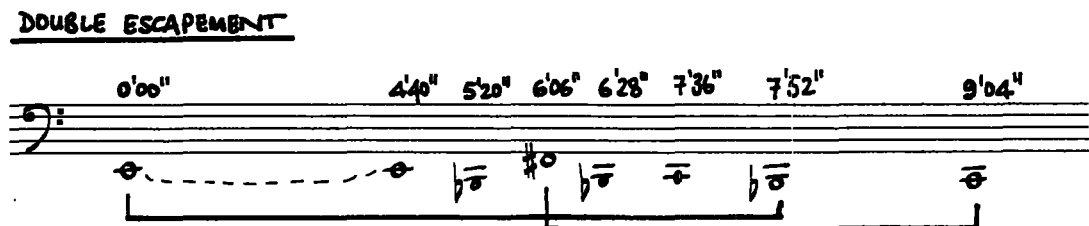

Albeit widely spaced this progression can be heard clearly during the piece and is assisted by the slow harmonic rhythm and by the fact that the majority of the pitch material is placed several octaves above the bass line. The importance given to this bass line is an attempt to reject the 'fudged' harmonic language that I (and many other younger composers) have used in the past which often avoids

any specific harmonic implication.

Above the bass line other harmonic areas (often clusters related in some way to the bass) vie for prominence. These areas are shown in the diagram below (Figure 23)

**Figure 23**

chords of consonance (04' 57")

chords of dissonance (04' 44")

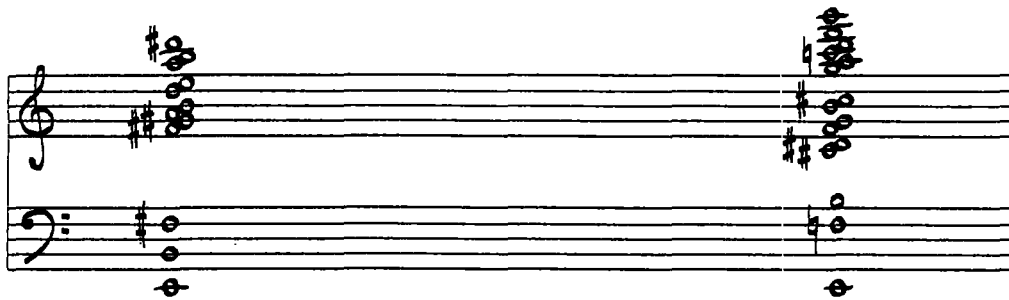

The two chordal areas above (shown as collective resonances for the passages in question) share a common 'fundamental', and intervals (2nds, 4ths) though have entirely different harmonic functions: consonance and dissonance. The alternation of these two basic formations and the linear material which interject comprises the majority of the music in the second section of the work.

As mentioned already (page 71) additional pitch material was derived from a *Hypercard* program (*PitchTwister*) which facilitates the creation and transformation of pitch material. Techniques include manipulating random numbers of any given range, creating grids for prime and inversion orderings of rows of any length and applying random and weighted random processes to primes. A typical 'Random Grid' is shown in Figure 25a and demonstrates how this relates to a passage in the composition in Figure 25b.

# PITCH GRID 1

	1	2	3	4	5	6	
	↓	↓	↓	↓	↓	↓	
← 12	4	10	1	8	2	3	
← 11	10	4	7	2	8	9	
← 10	7	1	4	11	5	6	
← 9	0	6	9	4	10	11	
← 8	6	0	3	10	4	5	
← 7	5	11	2	9	3	4	

## Process:

The 6x6 pitch grid (shown left) was created from a random hexachord and is typical of the grids used in the composition of the faster sections of *Double Escapement*. There is no continuously systematic approach to the use of these grids, though they did form the basis of many sections of the piece.

The grid displays the transpositions and inversions of the hexachord. Each line (marked 1 - 12) was converted to a chord (shown in the first example below) and ordered according to the number arising from the random grid (also shown left). Diads or triads from each chord was then selected and used in the section.

These were then implemented in the passage of music which follows (with some free changes to the events).

MENU

ROTATE

FIND...



# RANDOM GRID

10	3	7	10	7	1	6	3	1	6	11	5
9	2	10	2	2	7	9	12	10	5	6	10
7	1	4	6	3	10	3	6	7	2	3	9
10	7	4	9	4	6	6	12	10	12	3	6
1	3	9	2	5	6	8	3	10	5	7	12
1	3	6	4	10	7	8	3	5	3	7	10
12	5	2	7	4	4	5	4	9	1	10	6
1	7	11	6	12	3	4	6	8	2	8	12
10	4	7	1	8	4	7	5	9	1	10	3
6	8	4	8	9	10	2	3	4	6	7	2
1	12	4	10	2	4	6	7	10	1	4	2
7	7	3	5	1	1	1	4	8	9	12	4

## CHORDS FROM GRID

Handwritten musical notation showing chords 1 through 8 on a single staff. Each chord is represented by a group of notes with accidentals, corresponding to the numbers in the first row of the 'RANDOM GRID' table.

Handwritten musical notation showing chords 9 through 12 on a single staff. Each chord is represented by a group of notes with accidentals, corresponding to the numbers in the second row of the 'RANDOM GRID' table.

## ORDERING FROM RANDOM GRID

Handwritten musical notation showing a sequence of chords ordered according to the 'RANDOM GRID'. The sequence of numbers is: 10, 3, 7, 10, 7, 1, 6, 3, 1, 6, 11, 5. Annotations above the staff indicate that the chord '10' becomes 'C4/B' and the chord '3' becomes 'C6/D'.

rotate <    rotate >    interleave    rand mix

MENU

P-I-R-IR



Musical score for the first system, featuring multiple staves with musical notation and circled fingerings. The notation includes notes, rests, and slurs. Circled numbers (1-12) indicate specific fingerings for various notes. A box labeled '04'44"' is positioned above the staves.

04'44"

tape

Musical score for the second system, continuing the notation and fingerings. It includes notes, rests, slurs, and circled fingerings (1-12). A box labeled '04'48"' is positioned above the staves.

04'48"

\* MODIFIED

Musical score for the third system, continuing the notation and fingerings. It includes notes, rests, slurs, and circled fingerings (1-12).

tape

Musical score for the fourth system, continuing the notation and fingerings. It includes notes, rests, slurs, and circled fingerings (1-12). A box labeled '04'52"' is positioned above the staves.

04'52"

04'56"

### Rhythmic features

In addition to the simple sextuplet figuration which is used in many passages of the piece much of the rhythmic material of sections such as 04'40" is derived from the following rhythmic talea which was modified by free subdivisions and distortions of the individual units. The example below (Figure 26) shows three subsequent variations of this rhythmic material which relate to the passage starting at 4'40" in the piece. (The sextuplet material breaks into the middle of the third variation). Such a process of variation allows for rhythmic diversity but helps retain a degree of continuity in the flow of the music.

Figure 26

Figure 26 displays three variations of a rhythmic talea, each on a single staff with a treble clef. The first variation is labeled "04'40\" and features a sextuplet of eighth notes with a "3" above it. The second variation is labeled "(04'46\" and also features a sextuplet of eighth notes with a "3" above it. The third variation is labeled "[04'52\" and features a sextuplet of eighth notes with a "3" above it. Below the third variation, there is a note: "[fragmented by —6— material]".

### **The Electro-acoustic sounds of *Double Escapement***

As mentioned in the introduction, *Double Escapement* is the first piece in a larger cycle of electro-acoustic piano pieces which has been planned. It is envisaged that each piece in the cycle will explore a different aspect of piano technique or piano timbre. The idea behind *Double Escapement*, as the first in the cycle, was of leading the listener into the simple, un-transformed sound world of the piano and enveloping the listener in the piano timbre through multi-loudspeaker diffusion. To do this the tape sounds concentrate on minor transformations of piano sounds, for example pitch doublings with subtle detuning or attackless timbres, and on the rhythmic layering and complexity to assist in the overpowering impression which the piece seeks to achieve. (Much of this was achieved using superimposed zones on the *S1000* Sampler.) Whilst there is not a wide palette of sounds in *Double Escapement* it was my desire to focus on the subtle juxtaposition and superimposition of these timbres. For example the opening passage concentrates on the phasing effects which arise from the transposition of the sampled E pitch. Successive transpositions produce a slower rate of repeated notes. In addition, each event comprises at least two sounds: a crescendo gesture and diminuendo sample which are overlapped to exploit the phasing possibilities of the two patterns. Additional layers are added to this texture by multiple delays from external effects processors.

The only particularly unusual timbre in the piece is the last note (a transformed harmonic) which forms a link to the next piece which will explore static and unconventional piano timbres.

**A Slow Dance**

(1992)

*Back**Seskilgreen**The Dance / Message**For the Hillmother*

for soprano, alto, tenor, bass and tape

(duration: 17')

*Commissioned by the 1992 New Macnaughten Concerts with funding from the London Arts Board*

*First performance:*                      *1992 New Macnaughten Concerts*  
*22 October 1992*  
*St Giles Church, Cripplegate, Barbican, London*  
*Singcircle, conductor: Gregory Rose*

*Broadcast:*                                      *9 April 1993*  
*BBC Radio 3 - Midnight Oil.*  
*Singcircle, conductor: Gregory Rose*

*Selected for performance at the 1993 International Computer Music Conference, Japan.***Introduction**

The collection of poems by the Irish/American poet John Montague entitled *A Slow Dance* came to my attention some three years before the composition of this piece. At that stage I had imagined that its influence would find a way into the composition of *Making a Song and Dance...* though by that time I had become engrossed with the harmonic and melodic qualities of the folksong the *Lasses of Donaghadee* and retained the Montague text for some future project. There were a number of qualities in these poems which appealed greatly to me;



not least of these were the dark and often sinister images of birth, life, death and decay, and the constant feeling of movement depicted in almost every part of the text. (This latter point supports further my interest in dance, gesture and ritual in recent works such as *Perichoresis*.) At another level the poems appeared to be timeless, or at least moving in very slow motion; passages such as the opening of *Back* or the end of *Seskilgreen* create this atmosphere particularly well and I was anxious not to lose this quality in the process of composition.

Whilst the poems are quite clearly rhythmical and often 'musical' (in terms of the sounds of the spoken text) my initial work suggested two important things; firstly that the goal-oriented structures and fast harmonic rhythm typical of the compositions preceding *A Slow Dance* were inconsistent with the pacing of these poems, and secondly that the harmonic material which I was attempting to force onto the text was less suitable than pure speech and extended vocal sounds. Both of these points were addressed when the harmonic rhythm was slowed considerably and the pacing and direction of the music became less obsessed with building large-scale dramatic structures and more focussed on the mood and quality of the music and text at any given point. The speech and extended vocal sounds were in fact used in *Dance* and *Message* to heighten the qualities of the text.

Beyond the considerations outlined above lay a more fundamental challenge, that of transferring these ideas into the medium of electro-acoustic music with its complex resources and processes. Ideas, such as 'transparency' and 'fragility', which I associate with the musical language of *A Slow Dance*, seem less common in much of today's electro-acoustic music where high loudspeaker levels and complex noise spectra seem all too prevalent. It was my aim to

engage the full armory of a sophisticated computer music system whilst not losing sight of these simple objectives. The following detailed discussion of the resources used and their relationship with the text and music will reveal a greater understanding of my intentions in this piece: this includes an examination of the different electro-acoustic instruments created for use in the piece.

### **The electro-acoustic processes**

Despite having a wide range of resources at my disposal I decided that the entire piece would be composed on one system without reference to external analogue, digital or conventional mixing facilities; the final 'tape' sounds would in fact be first generation sounds. Such a restriction was by no means a limitation but proved to be a successful way of focussing on a small range of techniques and processes. The NeXT computer was the platform chosen for the composition, running software such as Csound, Cmix, NeXT MusicKit and IRCAM's Digital Signal Processing Workstation software. Very quickly it became apparent that the Csound software was fast and flexible enough to provide the majority of sound synthesis and manipulation techniques. Seeing the entire work through without recourse to external media also required considerable work in the later stages of mixing and required vast amounts of hard disk storage. (More than 2.5 GBytes of storage space was used during the composition of the piece.)

Much of the early work for the piece involved developing a wide range of timbres on the computer from which the desired soundworlds could be carved out. It also appeared that there was scope to cross-fertilize the computer sounds and live voice sounds whereby synthetic sounds could be developed to the point of being life-like and the sampled voice sounds transformed into noise-like timbres and

electronic sounds.

### **Csound Instruments and Scores**

The basic philosophy behind Csound, that of an instrument file containing precise instructions about timbre, being played or 'initialized' by events describing time, duration, pitch, and other variables in the score file is not too dissimilar from the conventional composition environment. Where this analogy breaks down is in the complexity of the programming required to develop these instrument and score files to anything resembling the sophistication of a musical instrument or the complex process of notation, interpretation and performance. A simple instruction in a conventional score, for example, 'with expression', can invoke a series of intricate and idiomatic distortions of the pitch, dynamics, and timing of musical gestures. If such nuances are to be possible with computers they require many hours of programming and a detailed familiarization with the controls of an instrument which exists only in terms of mathematical and acoustical data in Csound.

From the outset it had been my aim not to be lured into the possibilities of creating new synthesis methods (an altogether time-consuming activity which is possible in Csound because of the open-ended nature of the software), but to create a small and complex range of instruments and processes and exploit these to the full. The emphasis of my work lay in creating sophisticated orchestra files, some these as long as one thousand lines, controlled from the score file. These instruments were used to create or manipulate four basic categories of sound:

- 1) synthetic timbres (additive synthesis, frequency modulation)
- 2) synthetic voice or instrument -like timbres
- 3) transformed sampled sounds
- 4) heavily transformed sampled sounds

### **Sampling Instrument**

This is used frequently in the piece to create sounds which directly unify the live sounds and computer sounds. The process involves recording sound sources into the computer and then reading the resulting soundfile within a Csound instrument many times at short intervals. Depending on the control parameters of the Csound instrument, the output can appear to be static at one extreme or micro-polyphonic at another. The diagram below (Figure 27) illustrates this process and shows a series of 'windows', spaced at distances as small as 0.002 sec, which access the soundfile.

Figure 27

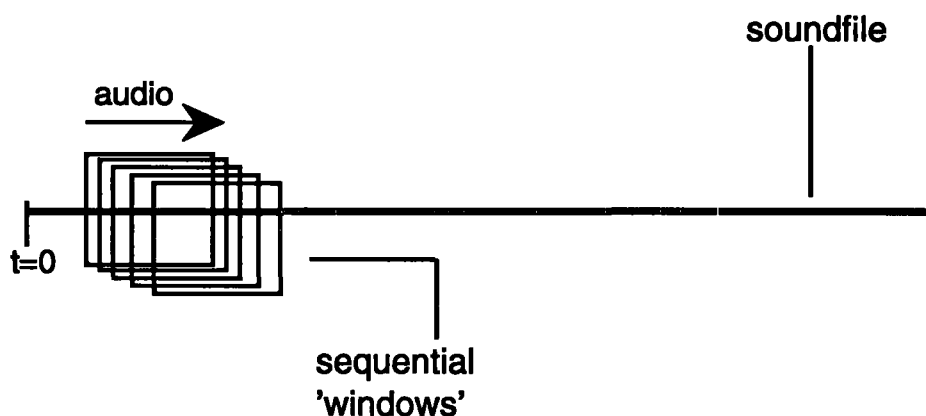

To make these sounds more interesting the parameters of the windows were constantly altered, often by simple procedures such as increasing the length of the window, shifting the horizontal position of the window and/or increasing or decreasing the number of windows. Throughout this process random fluctuations of timing and amplitude were also added to ensure a more life-like result. A typical instrument and score is shown in AppendixFive.

This technique is used to good effect in the opening minutes of *A Slow Dance* where the harmonic material of the live voices is pre-empted, supported or mirrored by sounds on the tape. For each chord that was treated a different sampling orchestra and score file was developed to ensure maximum diversity. What is perhaps most interesting is that the tape timbres at this point were derived from a recording of a linear sequence of pitches taken from the singers' chords and transformed using the technique described above, into complex

melodic lines or vertical sonorities. Thus they become animations of the static vocal chords to which they related.

### **Phase Vocoder Instrument**

In some respects the Phase Vocoder process is not unlike the sampling process described above and was used to create the computer sounds of the third section of the piece (*The Dance, Message*). It utilizes a Phase Vocoder model developed by Mark Dolson<sup>1</sup> which can be implemented within the Csound program. The attractions of the Phase Vocoder are many: complex, rich spectra can be produced quite quickly after the relatively lengthy process of running the analysis programme on the selected sound. The analysed data, containing spectral information on frequency and amplitude at intervals of 0.005 second, can then be read by a Csound Unit Generator called *pvoc* which has independent controls for the direction and speed of the resynthesis process. The power of the *pvoc* processor is considerable; a short passage of sound stretched many times, reveals information on the timbre and inner qualities of the sound in much the same way that a microscope examines visual images.

The Phase Vocoder instrument that I used employs several *pvoc* generators within a single instrument reading the analysis data simultaneously in different ways. This meant that a relatively simple score instruction could produce a complex range of timbres. The audio output from the *pvoc* generators was subjected to further processing using panning and amplitude variation. After a series of experiments it was apparent that the analysis data resulting from

---

<sup>1</sup> Mark Dolson, 'The Phase Vocoder Instrument: A Tutorial', Computer Music Journal, Vol.10 no.4 (1986) pp14-27.

speech worked particularly well and eventually a file derived from the word 'dance' was used to form the basic material of the second half of *The Dance*. The simplified diagram below (Figure 28) showing three pointers which can move in different directions and at different speeds through the analysis file shows the typical processes that were employed in this passage.

**Figure 28**

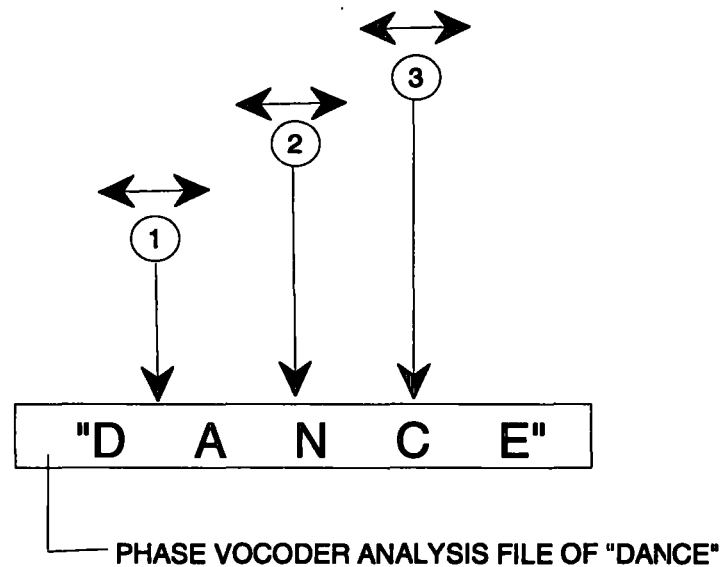

An example of the instrument and score files is shown in Appendix Five.

### **Voice-like Instruments**

This synthesis method has its origins in the Chant program and was developed and implemented in Csound as a FOF unit generator by Dr Michael Clarke<sup>2</sup>.

<sup>2</sup> J M Clarke, 'VOCEL. New Implementations of the FOF synthesis method', Proceedings of the International Computer Music Conference 1988, pp357-363.

The FOF generator, amongst the most complicated in Csound, allows the user to create basic voice-like timbres; the process of shaping these timbres into realistic musical sounds is an even more complicated business and requires further study of the behavior of vocal formants for the human voice.

Most of my early work on the NeXT was spent developing a series of convincing 'voice instruments' which could integrate with the live voices or dissolve into electronic timbres. Early experiments used single FOF generators and models using ten or more were developed later. One particular instrument, which contained nearly one thousand lines of code, allowed me to specify from parameter fields in the score up to three sequential male or female vowel sounds, (it was possible to map the male vowel parameters onto the female voice), glissandi to a different pitch and when during the duration of the event the glissandi would occur, reverberation, pitch spread, the rate of pitch spread, and accelerating and decelerating vibrato rates. Figure 29 shows the basic components of this instrument. A complete orchestra and score file is in Appendix Five.

By using conditional control statements such as 'if - then' within the instrument file it became possible to develop this model further and allow the value of a single number in a parameter field of the score to represent a particular chain of events in the orchestra.

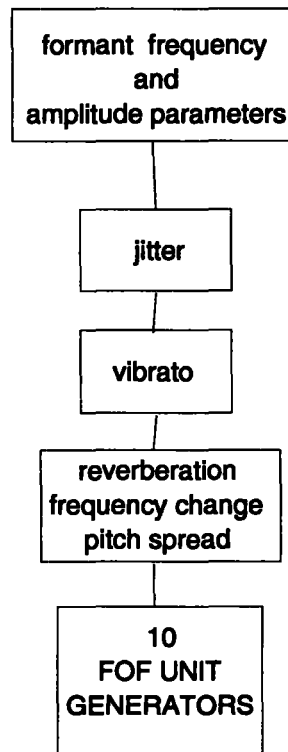
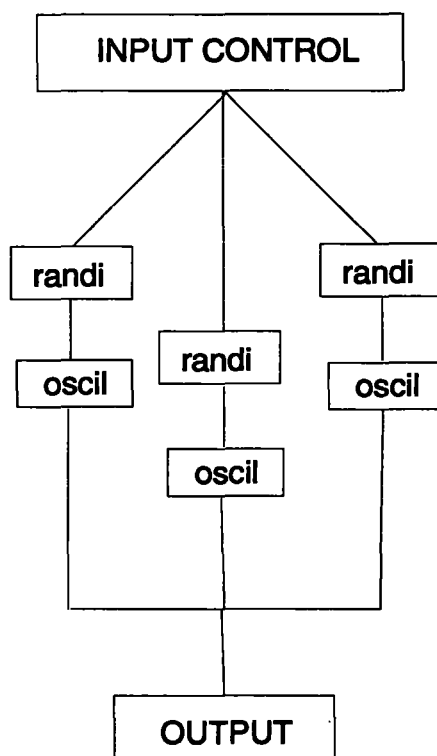

**Figure 29**

Manipulating the basic parameters of the FOF generator can provide interesting results. For example, reducing the basic frequency of the generator reveals the impulses of the synthesis method and produces a sound akin to vocal 'glottal clicks'. (This particular sound, used at the beginning and end of the first section, and the final moments of the piece, is linked quite closely to the images conjured up in the text and will be discussed in detail later.)

### **Granular Instrument**

In the composition of instrumental music chance discoveries are not uncommon. For many composers they are key moments in the composition process. To quote Stravinsky, "An accident is perhaps the only thing that really inspires us". Such accidents are less common when working within the exacting procedures of computer synthesis where, more often than not, a 'slip of the hand' results in no sound. However the granular Csound instrument being discussed here was developed from a failed experiment with random number generators and produced one of the more unusual instruments used in *A Slow Dance*. By applying random number generators ( *randi* ) to the frequency input of an FM instrument a granulated texture can be produced at the output. Additional generators linked to the index of modulation allow the sidebands of the instrument to be controlled as well. The final 'granular instrument' (shown in Figure 30 below) allows rich pointillistic timbres to evolve by controlling the range of the random generators and controlling the amplitude and pan position of the output.

**Figure 30**

With this instrument extended evolving textures were created from one event listed in the score. In *The Dance* (section III) the electronic sounds which underpin the middle section of spoken bass part (from 'then the dance begins...') were created from a few score events of 100 seconds' duration. An example of a granular orchestra and score can be seen in Appendix Five.

### **Other Instruments**

In contrast to the complex instruments discussed above several other acoustic sampled sounds were explored. The crotale events which feature in *Seskilgreen* and provide punctuation in several other places are simply sampled, filtered, panned and amplitude modulated. Another instrument was created which uses sine waves artificially to extend the resonance of the crotales. These become timbres in their own right in the middle passages of *Seskilgreen* and *For the Hillmother* and, in the case of the latter, become glissandi events pre-empting the descending vocal lines which appear in the passage at 14'18".

For the final mix-down of the work a special instrument and score were developed resembling the functions of a mixing desk which allowed me to specify the time of entry and amplitude profile of the compiled soundfiles, and to add effects such as reverberation and panning. This meant that multiple versions of the piece could be created, each with slightly varying parameters.

### **Relationship between Text and Music**

Each of the five selected poems from Montague's collection conveyed strong images through key words in the text or by the general tone of the poetry. These words were extracted at the start of writing and became central to the compositional process.

They are as follows:

***Back***

*Darkness*

*earth womb*

*slowly*

*lonely dance*

*whirling arms*

*shuffle*

*flying*

*flashing*

*echoing*

*earth*

*(interpreted images: distance, birth, organic growth)*

*(musical metaphors: reverberation, the creation of a timbre, slow harmonic rhythm, movement)*

***Seskilgreen***

*circle*

*secret dance*

*sleepily*

*(interpreted images: landscape, grave, birth, nature/mother earth )*

*(musical metaphors: consonance, resonance)*

**The Dance**

*silence*

*isolation*

*the head lolls, a broken stalk*

*body rags*

*a soft drum*

*The dance begins*

*the purse of your loins striking against your thighs*

*a windbreath light*

*In wet and darkness you are reborn*

*wet hair clinging*

*humus and mould*

*(interpreted images: death, decay, unity with the earth)*

*(musical metaphors: noise-like timbres, cluster/dense harmonic timbres, articulation, fragmentation)*

**Message**

*a body heavy as earth*

*her secret message*

*quartz*

*spider's web*

*so novice, blind*

*her sunless breasts*

*(interpreted images: at one with 'mother earth')*

*(musical metaphors: cluster/dense harmonic timbres becoming consonant)*

***For the Hillmother***

*Hill of motherhood*

*Gate of Birth*

*(interpreted images: objects of natural beauty, versicle and response)*

*(musical metaphors: versicle and response, harmonic simplicity, consonance)*

The translation of these phrases and images into sound is an entirely subjective process and relies heavily on one's compositional language. My approach to this was to combine the possibilities which were available in my Csound instruments with my predilection for certain harmonic and melodic procedures.

In *Back* I used synthetic glottal sounds (which evolve into a voice) and accumulating fragments of speech on tape to create a feeling of distance and organic growth. The imitative hummed vocal lines at the opening are internalized vocal sounds and provide a link to womb-like images expressed in the text. The glottal sounds, whispered fragments and voice sounds become eventually the first harmonic block of the piece. During the passage 1'24" to 3'24" the widely spaced harmonic events, low dynamics, and the expansion and contraction of lines provide the music with a slow 'breathing' quality.

The second half of *Back* bursts into frantic activity accompanied by loud tape sounds (transformations of previous material) and punctuating metallic timbres whilst the voice parts decorate an expanded version of the cluster harmony found at 1'24" on key words such as 'whirling', 'flying' and 'flashing'. This unwinds to the tape material of the opening passage (glottal sounds) linking the word 'earth' at each end of the text.

*Seskilgreen* uses a more resonant and consonant harmonic language with simpler tape sounds (processed crotale sounds and sinewave timbres) to create an 'open' musical landscape. As the pitch material unfolds an F# dorian 'tonality' becomes clearly established (supported by synthetic voice sounds) before crossfading with the static Phase Vocoder sounds of the opening of *The Dance*.

The use of spoken voice and text fragments in *The Dance* was to help create an intimate and sinister atmosphere. I chose to mirror the build-up of intensity in the text by using an accumulating granular texture in the background (which crescendos, rises in register and increases in brightness) supporting an increasingly frenzied spoken bass line and vocal utterances in the other parts. The vowel sound of the final word of the text ('mould') is superceded by a filtered white noise sound on tape (11'02") which then builds to an explosion - perhaps representing a superhuman vocal utterance. This provides sharp transition to the Phase Vocoder sounds used in *Message*.

In *Message* the rôles of spoken voice and background texture are reversed. The tape now carries the text whilst the voices provide an undulating harmonic backcloth which provides a link to the sung material of the last section. In *Message* there is a conscious effort to borrow some of the ideas found in *Back* such as internalized vocal sounds, cluster-like harmony (displaced 4ths) and a focus on the vocal sounds of the tape.

*For the Hillmother* uses ideas and gestures from *Seskilgreen* such as the solo voice to open the section, simple methods of punctuating the vocal lines (low 'bass drum' timbre) and the dorian F# 'tonality' at the very end. The versicle and



response is the initial structural device used here and it soon becomes absorbed into descending vocal lines which characterize the middle passage of the section. The work ends with a return of the 'bass drum' timbre (or 'heartbeat') and the glottal sounds from the opening receding to infinity.

The Figure 31 illustrating the musical and structural relationships of the piece clearly shows the links between the first and third and the second and fourth sections. These and other simple relationships, including the use of particular timbres, help to create one of the more interesting formal schemes of my recent pieces. It is arguable that the strongest aspect of this is the absence of a conventional climax passage and the continuity provided by relatively slow, sustained music.

Figure 31

*A Slow Dance - structural parallels*

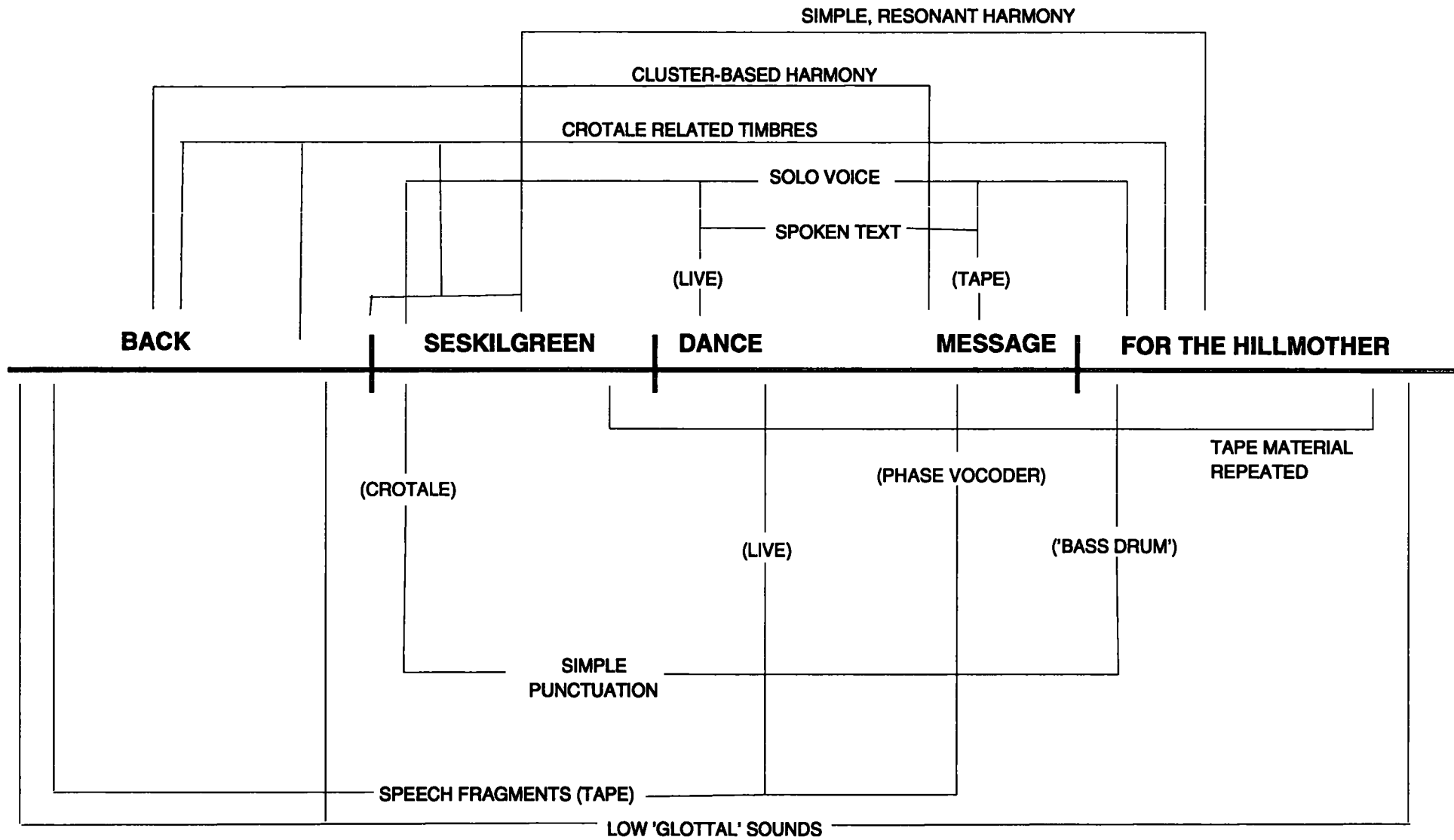

## **APPENDIX ONE**

### **Notes on the recordings submitted as part of the portfolio**

#### ***Recycle***

*Northern Sinfonia Ensemble*

*Composers Workshop - directed by John Casken*

*February 1987*

*University of Durham*

#### ***Incantation***

*The Queen's University Symphony Orchestra*

*conducted by Michael Alcorn*

*December 1992*

*Whitla Hall, Belfast*

*(although there are a number of inaccuracies in the performance, this version comes closest to my ideal performance of the piece)*

#### ***Calypso's Song to Ulysses***

*As yet unperformed professionally. The work was rehearsed at an SPNM workshop at the University of York in 1988 from which no recorded material was produced. The piece is programmed for performance at the Guildhall School of Music and Drama in June 1993.*

#### ***Making a Song a Dance . . .***

*Sequenza*

*Studio recording for release on Neuma CD label in 1993*

*July 1992, Harty Room at Queen's University*

**Voyager**

DAT recording (cassette backup enclosed)

1. *Pupils Glenlola High School, Bangor*  
*Directed by Michael Alcorn*  
*April 1993, Harty Room at Queen's University*
2. *Tape only*

**Perichoresis**

*Nash Ensemble*  
*Belfast Music Society*  
*October 1990, Elmwood Hall, Belfast*  
*(BBC Radio 3 recording)*

**Double Escapement**

DAT recording (cassette backup enclosed)

1. *MIDI realisation*  
*Studio III at Queen's University*  
*January 1993*
2. *Tape only*

**A Slow Dance**

DAT recording (cassette backup enclosed)

1. *Singcircle*  
*director - Gregory Rose*  
*Midnight Oil - BBC Radio 3*  
*April 1993*
2. *Tape only*

## APPENDIX TWO

### Incantation - detailed structure

A - punctuating chord + g/a texture

B - Lyrical melody based on

C - low cluster counterpoint

D - rising three note motif (tritone based)

E - frozen harmony

Z - textural counterpoint

Y - textural counterpoint - sustained pitches

X - aleatoric textures

W - aleatoric punctuation

bar	material
-----	----------

1	A
---	---

4	A
---	---

6	B
---	---

7	a + Z
---	-------

10	A
----	---

14	C
----	---

21	D
----	---

23	C
----	---

27	B
----	---

30	Z
----	---

33	E
----	---

36	C
----	---

37	E
----	---

38	A
44	E
46	Y + X
56	W
57	X
67	B related
76	E
80	E
83	W
84	X
85	A related (g/a transposed to f#/g - slower)
92	Y (harmonics)
94	A extended to melody with Y - (harmonics)
97	A extended to melody with Y - (harmonics)
107	A related
113	Y (harmonics) + A expanded
121	A expanded + (picc/ob1)
125	A expanded + / Z
136	A expanded
142	E
149	C related
162	X
162.3	W
163.4	E
162.5	W
163	E related
166	A
168	A developed
179	E related
185	A (becoming B) with X
206	W
207	X

207.4	E
208	E related
209	E with flourish
213	D related
220	B
238	D + E
248	D related
268	E
271	X & C (elongated)
281	E
282	W
283	A related & E
289	X & A

## APPENDIX THREE

The following photographs were copied from slides with the kind permission of the Armagh Planetarium.

	time against the score
<b>Slide 1 -</b>	
Eruption on the moon Io	1'17"
<b>Slide 2 -</b>	
High altitude clouds over Neptune	2'48"
<b>Slide 3 -</b>	
Callisto	3'37"
<b>Slide 4 -</b>	
The Tarantula Nebula, 30 Doradus	4'30"
<b>Slide 5 -</b>	
Triton - Oblique View	6'30"
<b>Slide 6 -</b>	
A crescent Uranus	7'03"
<b>Slide 7 -</b>	
The "C" ring - Saturn	8'41"



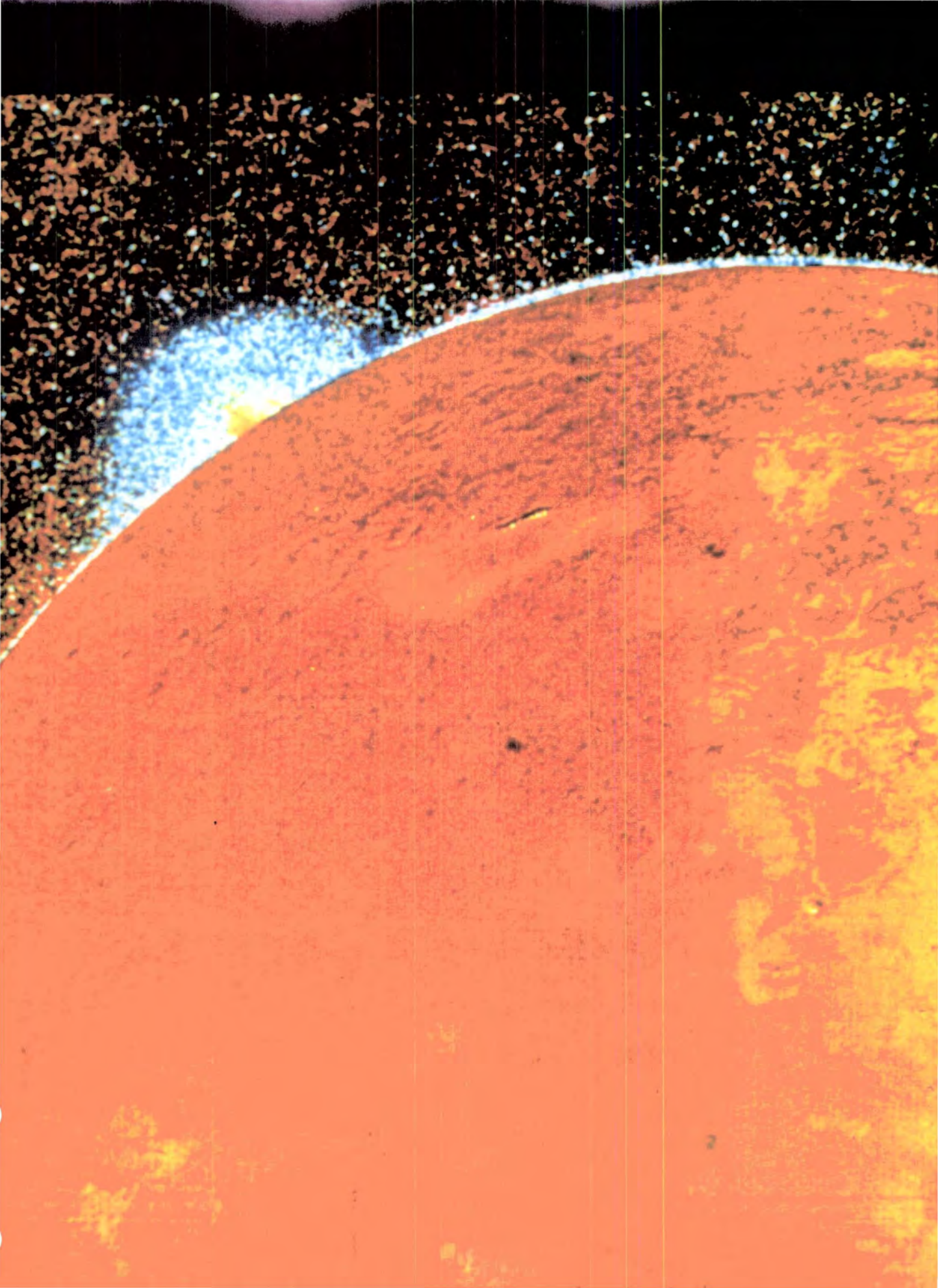



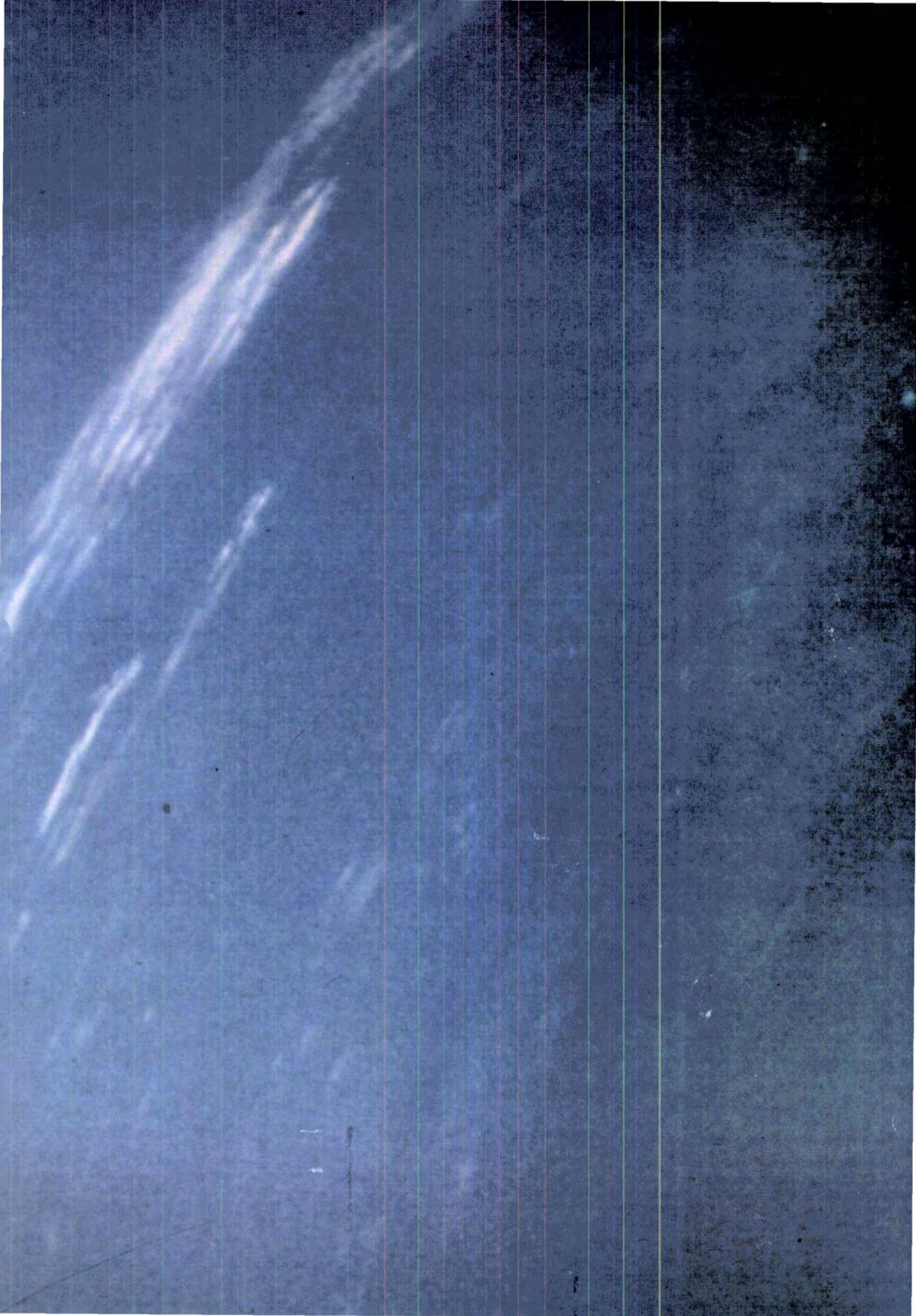



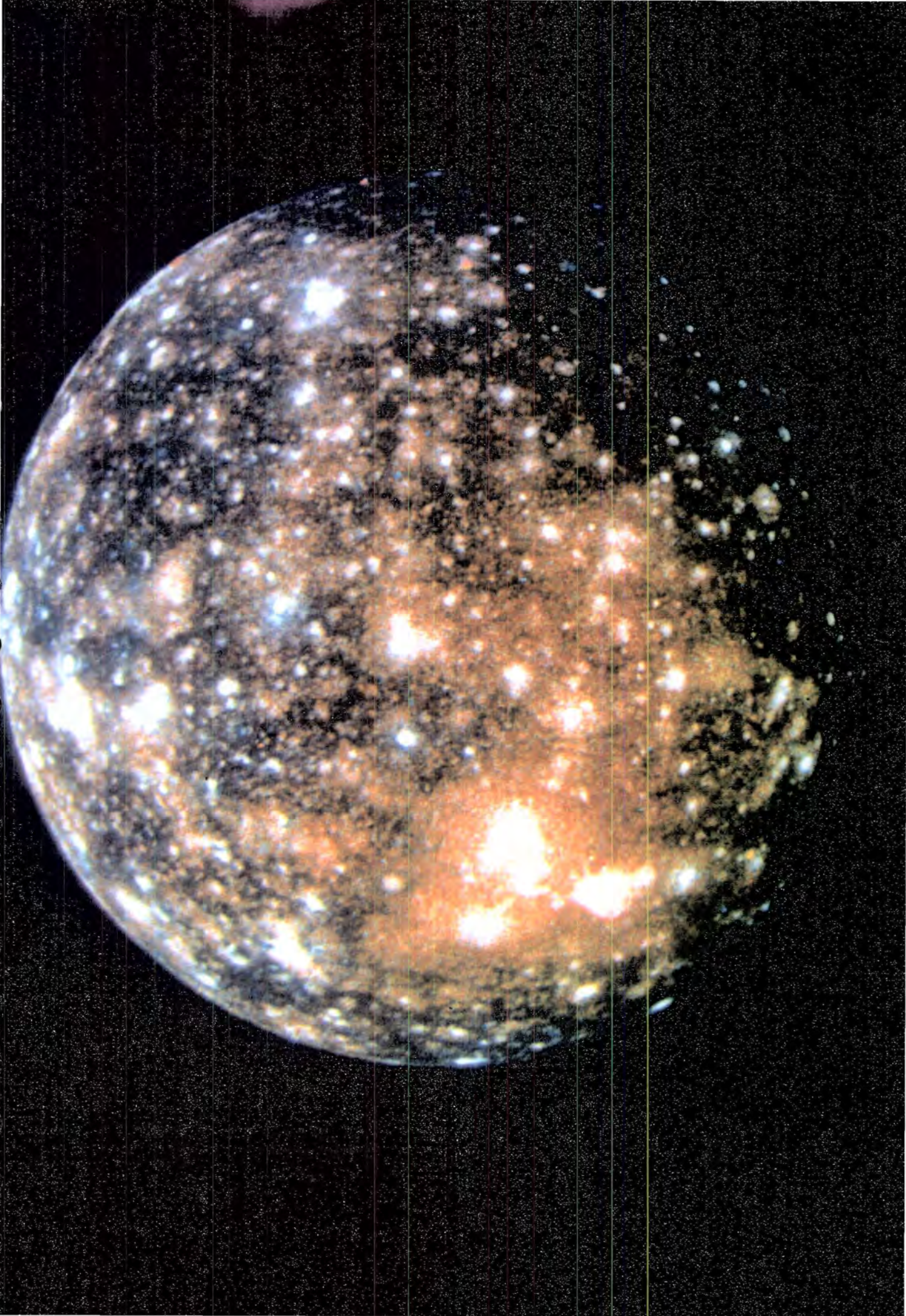











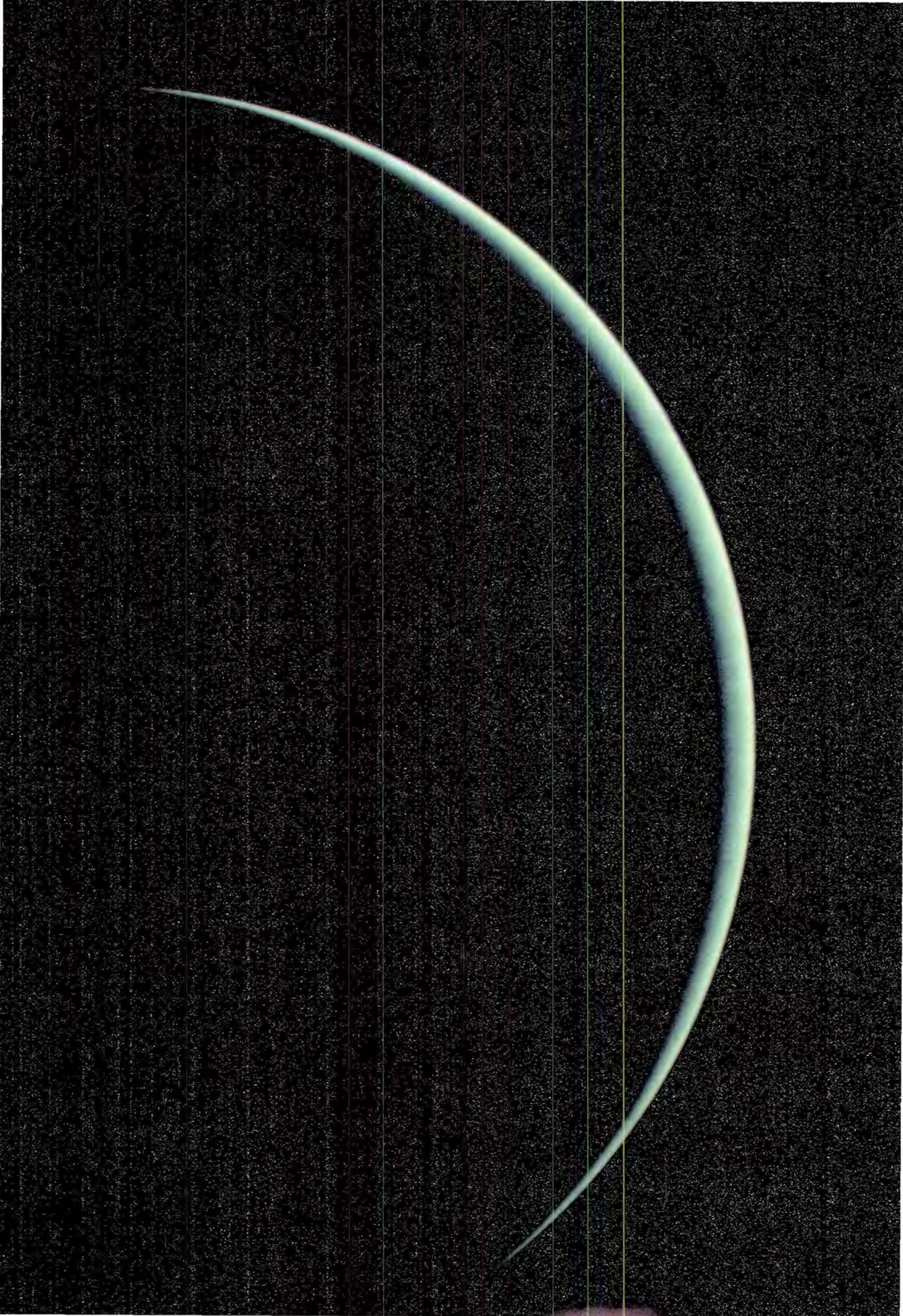



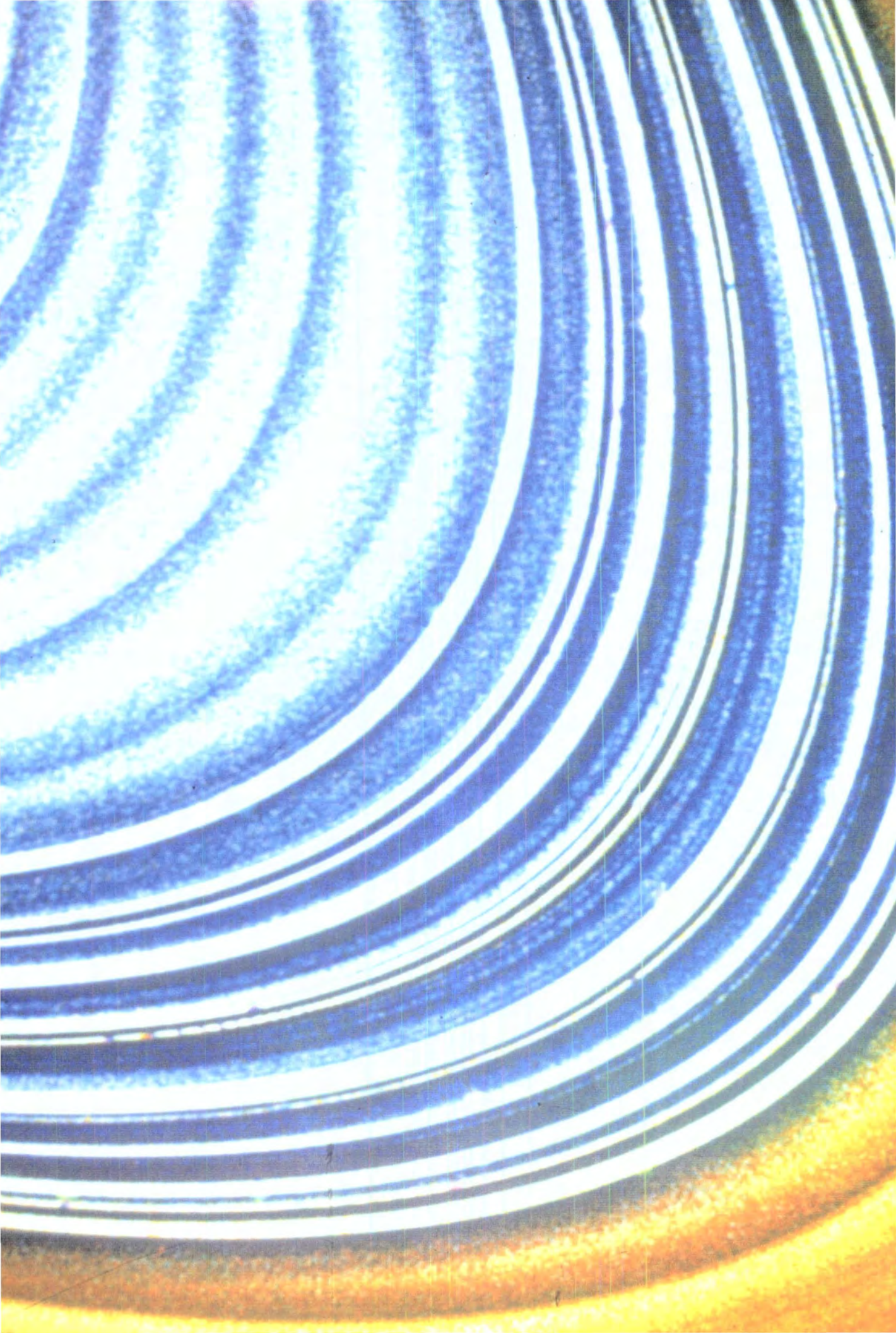

## APPENDIX FOUR

The following examples show the main facilities of the program

*PitchTwister*. The first example is the notation interface which allows the user either to click on note names or to play notes on a MIDI keyboard. The selected note is then displayed on the staff (in the order of selection).

The controls *P-I-R-IR*, *ROTATE*, *Find* (not yet implemented) navigate to another card which displays permutations of the row.

*P-I-R-IR* displays prime, inversion, retrograde and retrograde inversions of the row (example on next page)), whilst *Rotate* displays the original row and allows the use to move the pitches around the grid, for example by rotating the pitches to the left (as shown in the example on the last page).

The *Rand mix* will create a random pattern from the prime. Double clicking this button produces a totally random grid.



# PITCH TWISTER



C		F	G		Bb
---	--	---	---	--	----

reset stave

play

---

P-I-R-IR

ROTATE

FIND...

LIBRARY

MIDI setup

4	6	8	9	11	1	2	3
3	4	6	8	9	11	1	2
2	3	4	6	8	9	11	1
1	2	3	4	6	8	9	11
11	1	2	3	4	6	8	9
9	11	1	2	3	4	6	8
8	9	11	1	2	3	4	6
6	8	9	11	1	2	3	4

New Button

rotate <    rotate >    interleave    rand mix

MENU

P-I-R-IR



4	6	8	9	11	1	2	3
2	4	8	3	4	1	8	4
8	9	6	8	3	3	11	9
9	2	3	11	6	2	6	2
3	1	2	2	3	2	11	3
2	4	4	1	4	6	1	3
8	6	6	8	3	1	3	8
8	6	3	6	4	6	2	3

New Button

rotate <    rotate >    interleave    rand mix

MENU

P-I-R-IR



## APPENDIX FIVE

### Csound instruments and scores

#### GRANULAR INSTRUMENT

#### ORCHESTRA FILE

```

sr=44100
kr=2205
ksmps=20
nchnls=2
instr 1
;          INPUT CONTROL
;
kamp linseg 0, p3*.5, .6, p3*.5, 1
k1 oscil 1, p10, 2
k2 = (k1+1)*.5
k3 = k2*p4*kamp
kindx line p7, p3, p7*30
;
;          RAND MODULE 1
;
krandsp1 line p10, p3*.8, p10*5
k4 randh p9, krandsp1
if k4 < .7 goto transp1
transp1: k4 = k4*100
kgliss1 linseg p5, p3*.7, p5*2
a1 foscili k3, kgliss1*k4, p6, kindx, p8,2
;
;
;          RAND MODULE 2
;
krandsp2 line p12, p3*.7, p12*6
k8 randh p11, krandsp2
if k8 < .7 goto transp2
transp2: k8 = k8*100
kgliss2 linseg p5, p3*.6, p5*1.9
a2 foscili k3, kgliss2*k8, p6, kindx, p8,2
;
;
;          RAND MODULE 3
;
krandsp3 line p14, p3*.9, p14*7
k12 randh p13, krandsp3

```

```

if k12 < .7 goto transp3
transp3: k12 = k12*100
kgliss3 linseg p5, p3*.8, p5*2.1
a3 foscili k3, kgliss3*k12, p6, kindx, p8,2
;
;      OUTPUT CONTROL
;
k20 oscil 1, p15*.5, 2
kpan1 = (k20+1)/2
a10 = a1*(1-kpan1)
a11 = a1*(0+kpan1)
;
k21 oscil 1, p15, 2
kpan1 = (k21+1)/2
a12 = a2*(1-kpan1)
a13 = a2*(0+kpan1)
;
k22 oscil 1, p15*.7, 2
kpan1 = (k22+1)/2
a14 = a3*(1-kpan1)
a15 = a3*(0+kpan1)
;
kampc linseg 0, p3*.1, 1, p3*.7, 1, p3*.2, 0
a20 = (a10+a12+a14)*.7
a21 = (a11+a13+a15)*.7
k13 line 2.5, p3, 1 ; was 2.5
aout1 reverb a20, k13
aout2 reverb a21, k13
outs aout1*kampc, aout2*kampc
endin

;instr 2
;a1  linseg 0, p3*.1, 1, p3*.8, 1, p3*.1, 0
;a2      = gaout1*a1
;a3      = gaout2*a1
;outs a2, a3
;endin

```

SCORE FILE for GRANULAR INSTRUMENT

```

t 0 60
c
f2 0 512 10 1
c

```

```

c  st dr  amp  cp car mod dx          rand1 rand2 rand3   pan
c
i1 0   100 1700 60 50 30 .12 .001 1.1 .001 2   .001 1.2 1
i2 0   100
i1 .25 100 1700 60 40 30 .15 .001 1.2 .001 1.8           .001 1.5 .5
i2 .25 100
i1 .35 100 1700 60 42 30 .19 .001 2   .001 1.4 .001 2.1 2
i2 .35 100
i1 .75 100 1700 60 34 30 .18 .001 2.3           .001 1.6 .001 1.7 2
i2 .75 100
i1 30  100 1200 1000 50 30 .19 .001 1.3 .001 2           .001 1.2 1
i2 30  100
i1 31  100 1200 1000 60 30 .20 .001 1.1 .001 2.001 1.5 .5
i2 31  100
i1 31.2 100 1200 1000 100 30 .10 .001 2 .001 .5 .001 2.1 .1
i2 31.2 100
i1 32.75 100 1200 1000 90 30 .11 .001 4 .001 .9.001 1.7 .5
i2 32.75 100
i1 45   100 1700 1500 10 30 .19 .001 1 .001 2.3 .001 2 .3
i2 45  100
f0 10
e

```

FOF VOICE INSTRUMENT

ORCHESTRA FILE

sr = 44100  
kr = 441  
ksmps = 100  
nchnls = 2

instr 2

;

;

REGION ONE

;

if p6 != 1 goto vowel2 ; 'a' vowel

ifreq1 = 609  
ifreq2 = 1000  
ifreq9 = 2450  
ifreq4 = 2700  
ifreq5 = 3240  
ifreq6 = 80  
iamp1 = 12  
iamp2 = 6  
iamp3 = 3  
iamp4 = 3.1  
iamp5 = .75  
iamp6 = .25

goto vowel1

vowel2: if p6 != 2 goto vowel3 ; 'e' vowel

ifreq1 = 400  
ifreq2 = 1700  
ifreq9 = 2300  
ifreq4 = 2900  
ifreq5 = 3400  
ifreq6 = 80  
iamp1 = 12  
iamp2 = 9  
iamp3 = 8.5  
iamp4 = 3.1  
iamp5 = .9  
iamp6 = .25

goto vowel1

```
;
vowel3:  if p6 != 3 goto vowel4 ; 'iy' vowel
         ifreq1 = 238
         ifreq2 = 1741
         ifreq3 = 2450
         ifreq4 = 2900
         ifreq5 = 4000
         ifreq6 = 80
         iamp1  = 12
         iamp2  = 1
         iamp3  = 1.4
         iamp4  = 1
         iamp5  = .3
         iamp6  = .15
goto voweln
;
vowel4:  if p6 != 4 goto vowel5 ; 'o' vowel
         ifreq1 = 325
         ifreq2 = 700
         ifreq3 = 2550
         ifreq4 = 2850
         ifreq5 = 3100
         ifreq6 = 80
         iamp1  = 12
         iamp2  = 3
         iamp3  = .6
         iamp4  = .7
         iamp5  = .4
         iamp6  = .15
goto voweln
;
vowel5:  if p6 != 5 goto vowel6 ; 'oo' vowel
         ifreq1 = 360
         ifreq2 = 750
         ifreq3 = 2400
         ifreq4 = 2675
         ifreq5 = 2950
         ifreq6 = 80
         iamp1  = 12
         iamp2  = 3
         iamp3  = .39
         iamp4  = .41
         iamp5  = .1
         iamp6  = .15
goto voweln
;
vowel6:  if p6 != 6 goto vowel7 ; 'u' vowel
         ifreq1 = 415
         ifreq2 = 1400
         ifreq3 = 2200
```



```
    ifreq4 = 2800
    ifreq5 = 3300
    ifreq6 = 80
    iamp1  = 12
    iamp2  = 3
    iamp3  = 2.6
    iamp4  = 1.5
    iamp5  = .29
    iamp6  = .15
goto voweln

;
vowel7: if p6 != 7 goto vowel8 ; 'er' vowel
    ifreq1 = 300
    ifreq2 = 1600
    ifreq3 = 2150
    ifreq4 = 2700
    ifreq5 = 3100
    ifreq6 = 80
    iamp1  = 12
    iamp2  = 2.8
    iamp3  = 3
    iamp4  = 2.6
    iamp5  = .3
    iamp6  = .15
goto voweln

;
vowel8: if p6 != 8 goto vowel9 ; 'uh' vowel
    ifreq1 = 400
    ifreq2 = 1050
    ifreq3 = 2200
    ifreq4 = 2650
    ifreq5 = 3100
    ifreq6 = 80
    iamp1  = 12
    iamp2  = 3
    iamp3  = 1.4
    iamp4  = 1
    iamp5  = .3
    iamp6  = .15
goto voweln

;
vowel9: if p6 != 9 goto vowel10 ; 'a' vowel
    ifreq1 = 650
    ifreq2 = 1100
    ifreq3 = 2860
    ifreq4 = 3300
    ifreq5 = 4500
```

```
        ifreq6 = 80
        iamp1  = 12
        iamp2  = 5.8
        iamp3  = 2.9
        iamp4  = 3
        iamp5  = 1.5
        iamp6  = .15
goto voweln
;
vowel10: if p6 != 10 goto vowel11 ; 'e' vowel
        ifreq1 = 500
        ifreq2 = 1750
        ifreq3 = 2450
        ifreq4 = 3350
        ifreq5 = 5000
        ifreq6 = 80
        iamp1  = 12
        iamp2  = 4.5
        iamp3  = 4.2
        iamp4  = 2.6
        iamp5  = 1.7
        iamp6  = .15
goto voweln
;
vowel11: if p6 != 11 goto vowel12 ; 'iy' vowel
        ifreq1 = 330
        ifreq2 = 2000
        ifreq3 = 2800
        ifreq4 = 3650
        ifreq5 = 5000
        ifreq6 = 80
        iamp1  = 12
        iamp2  = 2.8
        iamp3  = 3.1
        iamp4  = 3.25
        iamp5  = 1.6
        iamp6  = .15
goto voweln
;
vowel12: if p6 != 12 goto vowel13 ; 'o' vowel
        ifreq1 = 400
        ifreq2 = 840
        ifreq3 = 2800
        ifreq4 = 3250
        ifreq5 = 4500
        ifreq6 = 80
        iamp1  = 12
        iamp2  = 3
        iamp3  = .6
        iamp4  = .75
```

```

        iamp5 = .4
        iamp6 = .15

```

```
goto voweln
```

```
;
```

```

vowel13:ifreq1 = 280
        ifreq2 = 650
        ifreq3 = 2200
        ifreq4 = 3450
        ifreq5 = 4500
        ifreq6 = 80
        iamp1 = 12
        iamp2 = 1.75
        iamp3 = .1
        iamp4 = .05
        iamp5 = .03
        iamp6 = .02

```

```
goto voweln
```

```
;
```

```
;
```

```
;
```

REGION 'TWO'

```
voweln:
```

```

    if p7 != 1 goto vowel14 ; 'a' vowel
    ifreq7 = 609
    ifreq8 = 1000
    ifreq9 = 2450
    ifreq10 = 2700
    ifreq11 = 3240
    ifreq12 = 80
    iamp7 = 12
    iamp8 = 6
    iamp9 = 3
    iamp10 = 3.1
    iamp11 = .75
    iamp12 = .25

```

```
goto vowelnn
```

```
vowel14: if p7 != 2 goto vowel15 ; 'e' vowel
```

```

    ifreq7 = 400
    ifreq8 = 1700
    ifreq9 = 2300
    ifreq10 = 2900
    ifreq11 = 3400
    ifreq12 = 80
    iamp7 = 12
    iamp8 = 9
    iamp9 = 8.5
    iamp10 = 3.1
    iamp11 = .9
    iamp12 = .25

```

```
goto vowelnn
;
vowel15: if p7 != 3 goto vowel16 ; 'iy' vowel
        ifreq7 = 238
        ifreq8 = 1741
        ifreq9 = 2450
        ifreq10 = 2900
        ifreq11 = 4000
        ifreq12 = 80
        iamp7 = 12
        iamp8 = 1
        iamp9 = 1.4
        iamp10 = 1
        iamp11 = .3
        iamp12 = .15
goto vowelnn
;
vowel16: if p7 != 4 goto vowel17 ; 'o' vowel
        ifreq7 = 325
        ifreq8 = 700
        ifreq9 = 2550
        ifreq10 = 2850
        ifreq11 = 3100
        ifreq12 = 80
        iamp7 = 12
        iamp8 = 3
        iamp9 = .6
        iamp10 = .7
        iamp11 = .4
        iamp12 = .15
goto vowelnn
;
vowel17: if p7 != 5 goto vowel18 ; 'oo' vowel
        ifreq7 = 360
        ifreq8 = 750
        ifreq9 = 2400
        ifreq10 = 2675
        ifreq11 = 2950
        ifreq12 = 80
        iamp7 = 12
        iamp8 = 3
        iamp9 = .39
        iamp10 = .41
        iamp11 = .1
        iamp12 = .15
goto vowelnn
;
vowel18: if p7 != 6 goto vowel19 ; 'u' vowel
        ifreq7 = 415
        ifreq8 = 1400
```

```

        ifreq9 = 2200
        ifreq10 = 2800
        ifreq11 = 3300
        ifreq12 = 80
        iamp7 = 12
        iamp8 = 3
        iamp9 = 2.6
        iamp10 = 1.5
        iamp11 = .29
        iamp12 = .15
goto vowelnn -

;
vowel19: if p7 != 7 goto vowel20 ; 'er' vowel
        ifreq7 = 300
        ifreq8 = 1600
        ifreq9 = 2150
        ifreq10 = 2700
        ifreq11 = 3100
        ifreq12 = 80
        iamp7 = 12
        iamp8 = 2.8
        iamp9 = 3
        iamp10 = 2.6
        iamp11 = .3
        iamp12 = .15
goto vowelnn

;
vowel20: if p7 != 8 goto vowel21 ; 'uh' vowel
        ifreq7 = 400
        ifreq8 = 1050
        ifreq9 = 2200
        ifreq10 = 2650
        ifreq11 = 3100
        ifreq12 = 80
        iamp7 = 12
        iamp8 = 3
        iamp9 = 1.4
        iamp10 = 1
        iamp11 = .3
        iamp12 = .15
goto vowelnn

;
vowel21: if p7 != 9 goto vowel22 ; 'a' vowel
        ifreq7 = 650
        ifreq8 = 1100
        ifreq9 = 2860
        ifreq10 = 3300
        ifreq11 = 4500

```

```
        ifreq12 = 80
        iamp7   = 12
        iamp8   = 5.8
        iamp9   = 2.9
        iamp10  = 3
        iamp11  = 1.5
        iamp12  = .15
goto vowelnn
;
vowel22: if p7 != 10 goto vowel23 ; 'e' vowel
        ifreq7 = 500
        ifreq8 = 1750
        ifreq9 = 2450
        ifreq10 = 3350
        ifreq11 = 5000
        ifreq12 = 80
        iamp7   = 12
        iamp8   = 4.5
        iamp9   = 4.2
        iamp10  = 2.6
        iamp11  = 1.7
        iamp12  = .15
goto vowelnn
;
vowel23: if p7 != 11 goto vowel24 ; 'iy' vowel
        ifreq7 = 330
        ifreq8 = 2000
        ifreq9 = 2800
        ifreq10 = 3650
        ifreq11 = 5000
        ifreq12 = 80
        iamp7   = 12
        iamp8   = 2.8
        iamp9   = 3.1
        iamp10  = 3.25
        iamp11  = 1.6
        iamp12  = .15
goto vowelnn
;
vowel24: if p7 != 12 goto vowel25 ; 'o' vowel
        ifreq7 = 400
        ifreq8 = 840
        ifreq9 = 2800
        ifreq10 = 3250
        ifreq11 = 4500
        ifreq12 = 80
        iamp7   = 12
        iamp8   = 3
        iamp9   = .6
```

```

        iamp10 = .75
        iamp11 = .4
        iamp12 = .15
goto vowelnn
;
vowel25:ifreq7 = 280
        ifreq8 = 650
        ifreq9 = 2200
        ifreq10 = 3450
        ifreq11 = 4500
        ifreq12 = 80
        iamp7 = 12
        iamp8 = 1.75
        iamp9 = .1
        iamp10 = .05
        iamp11 = .03
        iamp12 = .02
goto vowelnn
;
;
;
vowelnn:
        if p8 != 1 goto vowel26 ; 'a' vowel
        ifreq13 = 609
        ifreq14 = 1000
        ifreq15 = 2450
        ifreq16 = 2700
        ifreq17 = 3240
        ifreq18 = 80
        iamp13 = 12
        iamp8 = 6
        iamp9 = 3
        iamp10 = 3.1
        iamp11 = .75
        iamp12 = .25
goto amptimbre

vowel26: if p8 != 2 goto vowel27 ; 'e' vowel
        ifreq13 = 400
        ifreq14 = 1700
        ifreq15 = 2300
        ifreq16 = 2900
        ifreq17 = 3400
        ifreq18 = 80
        iamp13 = 12
        iamp14 = 9
        iamp15 = 8.5
        iamp16 = 3.1
        iamp17 = .9
        iamp18 = .25

```

REGION THREE

```
goto amptimbre
;
vowel27: if p8 != 3 goto vowel28 ; 'iy' vowel
         ifreq13 = 238
         ifreq14 = 1741
         ifreq15 = 2450
         ifreq16 = 2900
         ifreq17 = 4000
         ifreq18 = 80
         iamp13  = 12
         iamp14  = 1
         iamp15  = 1.4
         iamp16  = 1
         iamp17  = .3
         iamp18  = .15
goto amptimbre
;
vowel28: if p8 != 4 goto vowel29 ; 'o' vowel
         ifreq13 = 325
         ifreq14 = 700
         ifreq15 = 2550
         ifreq16 = 2850
         ifreq17 = 3100
         ifreq18 = 80
         iamp13  = 12
         iamp14  = 3
         iamp15  = .6
         iamp16  = .7
         iamp17  = .4
         iamp18  = .15
goto amptimbre
;
vowel29: if p8 != 5 goto vowel30 ; 'oo' vowel
         ifreq13 = 360
         ifreq14 = 750
         ifreq15 = 2400
         ifreq16 = 2675
         ifreq17 = 2950
         ifreq18 = 80
         iamp13  = 12
         iamp14  = 3
         iamp15  = .39
         iamp16  = .41
         iamp17  = .1
         iamp18  = .15
goto amptimbre
;
vowel30: if p8 != 6 goto vowel31 ; 'u' vowel
         ifreq13 = 415
         ifreq14 = 1400
```



```
    ifreq15 = 2200
    ifreq16 = 2800
    ifreq17 = 3300
    ifreq18 = 80
    iamp13  = 12
    iamp14  = 3
    iamp15  = 2.6
    iamp16  = 1.5
    iamp17  = .29
    iamp18  = .15
goto amptimbre

;
vowel31: if p8 != 7 goto vowel32 ; 'er' vowel
    ifreq13 = 300
    ifreq14 = 1600
    ifreq15 = 2150
    ifreq16 = 2700
    ifreq17 = 3100
    ifreq18 = 80
    iamp13  = 12
    iamp14  = 2.8
    iamp15  = 3
    iamp16  = 2.6
    iamp17  = .3
    iamp18  = .15
goto amptimbre

;
vowel32: if p8 != 8 goto vowel33 ; 'uh' vowel
    ifreq13 = 400
    ifreq14 = 1050
    ifreq15 = 2200
    ifreq16 = 2650
    ifreq17 = 3100
    ifreq18 = 80
    iamp13  = 12
    iamp14  = 3
    iamp15  = 1.4
    iamp16  = 1
    iamp17  = .3
    iamp18  = .15
goto amptimbre

;
vowel33: if p8 != 9 goto vowel34 ; 'a' vowel
    ifreq13 = 650
    ifreq14 = 1100
    ifreq15 = 2860
    ifreq16 = 3300
    ifreq17 = 4500
```

```
        ifreq18 = 80
        iamp13  = 12
        iamp14  = 5.8
        iamp15  = 2.9
        iamp16  = 3
        iamp17  = 1.5
        iamp18  = .15
goto amptimbre
;
vowel34: if p8 != 10 goto vowel35 ; 'e' vowel
        ifreq13 = 500
        ifreq14 = 1750
        ifreq15 = 2450
        ifreq16 = 3350
        ifreq17 = 5000
        ifreq18 = 80
        iamp13  = 12
        iamp14  = 4.5
        iamp15  = 4.2
        iamp16  = 2.6
        iamp17  = 1.7
        iamp18  = .15
goto amptimbre
;
vowel35: if p8 != 11 goto vowel36 ; 'iy' vowel
        ifreq13 = 330
        ifreq14 = 2000
        ifreq15 = 2800
        ifreq16 = 3650
        ifreq17 = 5000
        ifreq18 = 80
        iamp13  = 12
        iamp14  = 2.8
        iamp15  = 3.1
        iamp16  = 3.25
        iamp17  = 1.6
        iamp18  = .15
goto amptimbre
;
vowel36: if p8 != 12 goto vowel37 ; 'o' vowel
        ifreq13 = 400
        ifreq14 = 840
        ifreq15 = 2800
        ifreq16 = 3250
        ifreq17 = 4500
        ifreq18 = 80
        iamp13  = 12
        iamp14  = 3
        iamp15  = .6
```

```

        iamp16 = .75
        iamp17 = .4
        iamp18 = .15
goto amptimbre
;
vowel37:ifreq13 = 280
        ifreq14 = 650
        ifreq15 = 2200
        ifreq16 = 3450
        ifreq17 = 4500
        ifreq18 = 80
        iamp13 = 12
        iamp14 = 1.75
        iamp15 = .1
        iamp16 = .05
        iamp17 = .03
        iamp18 = .02
goto amptimbre
;
;
amptimbre:
kp1      linseg ifreq1, p3*.15, ifreq1, p3*.3, ifreq7, p3*.35,
ifreq13, p3*.20, ifreq13
kp2      linseg ifreq2, p3*.15, ifreq2, p3*.3, ifreq8, p3*.35,
ifreq14, p3*.20, ifreq14
kp3      linseg ifreq3, p3*.15, ifreq3, p3*.3, ifreq9, p3*.35,
ifreq15, p3*.20, ifreq15
kp4      linseg ifreq4, p3*.15, ifreq4, p3*.3, ifreq10, p3*.35,
ifreq16, p3*.20, ifreq16
kp5      linseg ifreq5, p3*.15, ifreq5, p3*.3, ifreq11, p3*.35,
ifreq17, p3*.20, ifreq17
kp6      linseg ifreq6, p3*.15, ifreq6, p3*.3, ifreq12, p3*.35,
ifreq18, p3*.20, ifreq18

kkamp1   linseg iamp1, p3*.15, iamp1, p3*.3, iamp7, p3*.35, iamp13,
p3*.20, iamp13
kkamp2   linseg iamp2, p3*.15, iamp2, p3*.3, iamp8, p3*.35, iamp14,
p3*.20, iamp14
kkamp3   linseg iamp3, p3*.15, iamp3, p3*.3, iamp9, p3*.35, iamp15,
p3*.20, iamp15
kkamp4   linseg iamp4, p3*.15, iamp4, p3*.3, iamp10, p3*.35, iamp16,
p3*.20, iamp16
kkamp5   linseg iamp5, p3*.15, iamp5, p3*.3, iamp11, p3*.35, iamp17,
p3*.20, iamp17
kkamp6   linseg iamp6, p3*.15, iamp6, p3*.3, iamp12, p3*.35, iamp18,
p3*.20, iamp18
;        pitchchange

kpchchange linseg p5, p3*p14, p5, p3*.5, p13, p3*(1-p14), p13

```

```

k100      = (p5/100)*p12      ;pitch spread %
k101      randi k100, 4.6, .9
k102      = k101+k101/2
k103      oscil k100, k102, 1
k104      randi k100, 7.75, -1
k105      = k104+k104/2
k106      oscil k100, k105, 1
;
a1 linseg 0, p3*.4, p4, p3*.6, 0
;
k60       linseg  0, p3*.7, .015, p3*.3, 0
k70       linseg p10*.01, p3*.2, p10, p3*.5, p10, p3*.3, p10*.6
k20       randi   k60, 1/.91
k21       randi   k60, 1/1.7
k22       randi   k60, 1/1.015
k23       randi   k60, 1/.93
k24       =       .02*(k20+k21)
k25       =       k70*(k22+k23)
k2        oscili  p5/4, k70+k25,1
k3        =       k2*(.02+k24)
a2        randi   .01, 1/.05
a3        randi   .01, 1/.1111
a4        randi   .01, 1/1.2186
a5        =       a2+a3+a4+k3+kpchange;+k103
a5        = a5;-(a5*.017)
k600      linseg  0, p3*.4, .01, p3*.6, 0
k700      linseg p10*.01, p3*.1, p10, p3*.6, p10*.7, p3*.3, p10*.4
k200      randi   k600, 1/.6
k210      randi   k600, 1/1.02
k220      randi   k600, 1/1.02
k230      randi   k600, 1/.093
k240      =       .02*(k200+k210)
k250      =       k700*(k220+k230)
ki2       oscili  p5/3, k700+k250,1
ki2       =       ki2*(.02+k240)
ai2       randi   .01, 1/.012
ai3       randi   .01, 1/.19
ai4       randi   .01, 1/1.0315
a6        =       ai2+ai3+ai4+ki2+kpchange+k106*.9
a6        =       a6
;
kx600     linseg  0, p3*.5, .06, p3*.5, 0
kx700     linseg p10*.01, p3*.4, p10, p3*.5, p10*.6, p3*.1, p10*.5
kx200     randi   kx600, 1/.6
kx210     randi   kx600, 1/1.1
kx220     randi   kx600, 1/1.2
kx230     randi   kx600, 1/.9
kx240     =       .02*(kx200+kx210)
kx250     =       kx700*(kx220+kx230)

```

```

kxi2      oscili    p5/2, kx700+kx250,1
kxi2      =         kxi2*(.03+kx240)
axi2      randi    .01, 1/.04
axi3      randi    .01, 1/.09
axi4      randi    .01, 1/1.1
a7        =         (axi2+axi3+axi4+kxi2)*.8+kpchange
a7        = a7
;display a5, .1
;display a6, .1
;display a7, .1
;
a10 fof kkamp1,a5, kp1, 0, 1, .003, 77, .01, .007, p9, 1, 1, p3,0, 1
a20 fof kkamp2, a5, kp2, 0,1, .003, 88, .01, .007, p9, 1, 1, p3,0, 1
a30 fof kkamp3, a5, kp3, 0,1, .003, 122, .01, .007, p9, 1, 1, p3,0, 1
a40 fof kkamp4, a5, kp4, 0,1, .003, 127, .01, .007, p9, 1, 1, p3,0, 1
a50 fof kkamp5*.4, a5, kp5, 0,1, .003, 137, .01, .007, p9, 1, 1, p3,0,
1
a60 fof kkamp6, a5, p11, 0,1, .003, 70, .01, .007, p9, 1, 1, p3,0, 1

a70 fof kkamp1,a6, kp1, 0, 1, .003, 77, .01, .007, p9, 1, 1, p3,0, 1
a80 fof kkamp2, a6, kp2, 0,1, .003, 88, .01, .007, p9, 1, 1, p3,0, 1
a90 fof kkamp3, a6, kp3, 0,1, .003, 122, .01, .007, p9, 1, 1, p3,0, 1
a100 fof kkamp4, a6, kp4, 0,1, .003, 127, .01, .007, p9, 1, 1, p3,0, 1
a110 fof kkamp5*.4, a6, kp5, 0,1, .003, 137, .01, .007, p9, 1, 1,
p3,0, 1
a120 fof kkamp6, a6, p11, 0,1, .003, 70, .01, .007, p9, 1, 1, p3,0, 1

a130 fof kkamp1,a7, kp1, 0, 1, .003, 77, .01, .007, p9, 1, 1, p3,0, 1
a140 fof kkamp2, a7, kp2, 0,1, .003, 88, .01, .007, p9, 1, 1, p3,0, 1
a150 fof kkamp3, a7, kp3, 0,1, .003, 122, .01, .007, p9, 1, 1, p3,0, 1
a160 fof kkamp4, a7, kp4, 0,1, .003, 127, .01, .007, p9, 1, 1, p3,0, 1
a170 fof kkamp5*.4, a7, kp5, 0,1, .003, 137, .01, .007, p9, 1, 1,
p3,0, 1
a180 fof kkamp6, a7, p11, 0,1, .003, 70, .01, .007, p9, 1, 1, p3,0, 1

aadd = a130+a140+a150+a160+a170+a180
aout =
(a10+a20+a30+a40+a50+a60+a70+a80+a90+a100+a110+a120+aadd)*a1*.55
aoutr     reverb aout*.5, 1.2
aout1     = aout*(1-p11)
aout2     = aout*(0+p11)
outs aout1+aoutr, aout2+aoutr

endin

```

## SCORE FILE FOR FOF INSTRUMENT

f1 0 8193 10 1

f2 0 512 10 1

t 0 60

c p4 = pitch 1  
 c p5 = pitch 2  
 c p6 = pointer 1  
 c p7 = pointer 2  
 c p8 = pointer 3  
 c p9 = pan position

;a 0 0 6

i1	5	25	.9	.9	2.2	2.1	2	3	4	
i1	0	20	.5	.5	1.8	1.9	2	3	4	
i1	12	30	.8	.78	3.2	3.1	3	3	4	
i1	22	35	.7	.75	2.3	2.2	2.1	3	4	
i1	30	30	.99	.93	2	1.9	1.8	3	4	
i1	38	28	.6	.65	3	3.1	3.2	3	4	
i1	40	20	.8	.9	1.9	2	2.1	3	4	
i1	44	18	1	1	1.2	1.3	1.2	3	4	
i1	47	22	.7	.75	.9	1	.9	3	4	
i2	0	8	.9	.5	1.15	1.2	1.4	4	18	12
i1	0	8	1	.7	0	1	2	4	3.1	4

e

## PHASE VOCODER INSTRUMENT

## ORCHESTRA FILE

sr = 44100

kr = 441

ksmps = 100

nchnls = 2

```

instr 1
ktime linseg p6, p3*.5, p7, p3*.5, p8; changing speed
kptlin linseg p4, p3, p5
aout pvoc ktime, kptlin, 0, 12
aamp linseg 0, p3*.5, p10, p3*.5, 0
apreout =(aout*3)*aamp
areverb reverb apreout, .2
areverb = areverb*.3
if p9 != 1 goto pan1
apan1 linseg 0, p3*.3, 0, p3*.2, 1, p3*.1, 0, p3*.1, .5,

```

```

p3*.3, 1
        k1 linseg p11, p3, .0001
        a1 oscili 1, k1, 2
        apanx = (a1+a1)*.5
        apreout = apreout*(1-apanx)
aout1 = apreout*(1-apan1)
aout2 = apreout*(0+apan1)
goto outpan
pan1: if p9 != 2 goto pan2
apan1 linseg 1, p3*.3, 0, p3*.2, 0, p3*.1, 1, p3*.1, .5,
p3*.3, 0
        k1 linseg p11*.0001, p3*.5, p11, p3*.5, p11*.0001
        a1 oscili 1, k1, 2
        apanx = (a1+a1)*.5
        apreout = apreout*(1-apanx)
aout1 = apreout*(1-apan1)
aout2 = apreout*(0+apan1)
goto outpan
pan2: if p9 != 3 goto pan3
apan1 linseg
.5,p3*.5, .5,p3*.02,0,p3*.02,1,p3*.01,0,p3*.25, .5,p3*.1,0,p3*.1,1
aout1 = apreout*(1-apan1)
aout2 = apreout*(0+apan1)
goto outpan
pan3:   if p9 != 4 goto pan4
        k1 linseg p11, p3, .0001
        a1 oscili 1, k1, 2
        apan1 = (a1+a1)*.5
        aout1 = apreout*(1-apan1)
        aout2 = apreout*(0+apan1)
        goto outpan
pan4:   if p9 != 5 goto pan5
        apan1 linseg 0, p3*.3, 0, p3*.7, 1
        aout1 = apreout*(1-apan1)
        aout2 = apreout*(0+apan1)
        goto outpan
pan5:   apan1 linseg 1, p3*.3, 1, p3*.7, 0
        aout1 = apreout*(1-apan1)
        aout2 = apreout*(0+apan1)
        goto outpan
outpan: outs aout1+areverb, aout2+areverb
;outpan: outs   apreout*(1-apan1), apreout*(0+apan1)
        endin

instr      2
ktime     linseg  p6, p3*.5, p7, p3*.5, p8; changing speed
kptlin    linseg  p4, p3, p5
aout      pvoc    ktime, kptlin, 0, 12

```

```

;aamp   linseg   0, p3*.5, p10, p3*.5, 0
;aamp   expseg  0.001, p3*.06, p10, p3*.94, 0.00001
aamp    expseg   p10, p3, .000001
apreout =(aout*3)*aamp
areverb reverb apreout, .2
areverb = areverb*.3
if p9 != 1 goto pan1
apan1 linseg 0, p3*.3, 0, p3*.2, 1, p3*.1, 0, p3*.1, .5,
p3*.3, 1
        k1 linseg p11, p3, .0001
        a1 oscili 1, k1, 2
        apanx = (a1+a1)*.5
        apreout = apreout*(1-apanx)
aout1 = apreout*(1-apan1)
aout2 = apreout*(0+apan1)
goto outpan
pan1: if p9 != 2 goto pan2
apan1 linseg 1, p3*.3, 0, p3*.2, 0, p3*.1, 1, p3*.1, .5,
p3*.3, 0
        k1 linseg p11*.0001, p3*.5, p11, p3*.5, p11*.0001
        a1 oscili 1, k1, 2
        apanx = (a1+a1)*.5
        apreout = apreout*(1-apanx)
aout1 = apreout*(1-apan1)
aout2 = apreout*(0+apan1)
goto outpan
pan2: if p9 != 3 goto pan3
apan1 linseg
.5,p3*.5,.5,p3*.02,0,p3*.02,1,p3*.01,0,p3*.25,.5,p3*.1,0,p3*.1,1
aout1 = apreout*(1-apan1)
aout2 = apreout*(0+apan1)
goto outpan
pan3:   if p9 != 4 goto pan4
        k1 expseg p11, p3, .000001
        a1 oscili 1, k1, 2
        apan1 = (a1+a1)*.5
        aout1 = apreout*(1-apan1)
        aout2 = apreout*(0+apan1)
        goto outpan
pan4:   if p9 != 5 goto pan5
        apan1 linseg 0, p3*.3, 0, p3*.7, 1
        aout1 = apreout*(1-apan1)
        aout2 = apreout*(0+apan1)
        goto outpan
pan5:   apan1 linseg 1, p3*.3, 1, p3*.7, 0
        aout1 = apreout*(1-apan1)
        aout2 = apreout*(0+apan1)
        goto outpan
outpan: outs aout1+areverb, aout2+areverb
;outpan: outs   apreout*(1-apan1), apreout*(0+apan1)

```



PHASE VOCODER INSTRUMENT

SCORE FILE

f1 0 8193 10 1

f2 0 512 10 1

t 0 60

- c p4 = pitch 1
- c p5 = pitch 2
- c p6 = pointer 1
- c p7 = pointer 2
- c p8 = pointer 3
- c p9 = pan position

;a 0 0 6

i1 5	25	.9	.9	2.2	2.1	2	3	4
i1 0	20	.5	.5	1.8	1.9	2	3	4
i1 12	30	.8	.78	3.2	3.1	3	3	4
i1 22	35	.7	.75	2.3	2.2	2.1	3	4
i1 30	30	.99	.93	2	1.9	1.8	3	4
i1 38	28	.6	.65	3	3.1	3.2	3	4
i1 40	20	.8	.9	1.9	2	2.1	3	4
i1 44	18	1	1	1.2	1.3	1.2	3	4
i1 47	22	.7	.75	.9	1	.9	3	4

- f0 1
- f0 2
- f0 3
- f0 4
- f0 5
- f0 6
- f0 7
- f0 8
- f0 9
- f0 10
- e

# **A SLOW DANCE**

**for soprano, alto, tenor, bass and tape**

**Michael Alcorn**

**1992**

**Commissioned by the New Macnaghten Concerts with funding from the  
London Arts Board**



# Performance Instructions

## VOCAL STYLE:

The singers should sing without vibrato (unless indicated otherwise) with a slightly nasal, folky quality.

The spoken part for the bass in *The Dance* should reflect the dark and sinister qualities of the text. A whispered/half spoken voice should be used which builds in intensity following the contour and qualities of the tape sounds.

## TIMING:

Timings are given at the top of each page and for important structural points which will help cue the voice parts. This is not the case in the relatively free passages of *The Dance* where only the main textural changes in the tape are indicated.

The textural nature of many passages of the piece will allow for some degree of flexibility within sections though the singers should endeavour to keep this reasonably accurate. It is more important that the individual voice parts are themselves tightly coordinated, especially in sections which are purely homophonic.

Time 0'00" should be synchronised with id2 (02'06") on the DAT.

## TAPE:

The tape may require 2-3 dB boost on HF and 2-3 dB cut on LF on the desk's EQ.

A reverb of 1 - 1.5 secs should be mixed into the amplified voice sounds.

Care should be taken throughout to ensure that the tape and amplified voices are always equally balanced.

The bass in *The Dance* may need additional EQ to emphasise the darker qualities of the voice.

**TEXT:** from a collection of poems called **A Slow Dance** by John Montague.

**BACK**

Darkness, cave  
drip, earth womb  
we move slowly  
back to our origins

the naked salute  
to the sun disc  
the obeisance  
to the antlered tree

the lonely dance  
on the grass

earth darkness  
clouded moon

whirling arms  
they shuffle

hair flying  
eyes flashing

instep echoing  
one, two as

bare heels, toe  
smite the earth

**SESKILGREEN**

A circle of stones  
surviving behind a  
guttery farmhouse

the capstone phallic  
in a thistly meadow:  
Seskilgreen Passage Grave.

Cup, circle,  
triangle beating  
their secret dance

(eyes, breasts,  
thighs of a still  
fragrant goddess).

I came last in May  
to find the mound  
drowned in bluebells

with a fearless wren  
hoarding speckled eggs  
in a stony crevice

while cattle  
swayed sleepily  
under low branches

lashing the ropes  
of their tails  
across the centuries.

## **THE DANCE**

In silence and isolation the dance begins. No one is meant to watch, least of all yourself. Hands fall to the sides, the head lolls, empty, a broken stalk. The shoes fall away from the feet, the clothes peel away from the skin, body rags. The sight has slowly faded from your eyes, that sight of habit that sees nothing. Your ears buzz a little before they retreat to where the heart pulses, a soft drum. Then the dance begins, cleansing, healing. Through the bare forehead, along the bones of the feet, the earth begins to speak. One knee lifts rustily, then the other. Totally absent, you shuffle up and down, the purse of your loins striking against your thighs. From where the legs join the rhythm spreads upwards - the cage of the ribs whistling - to pass down the arms like electricity along a wire. On the skin moisture forms, a wet leaf or a windbreath light as a mayfly. In wet and darkness you are reborn, the rain falling on your face as it would on a mossy tree trunk, wet hair clinging to your skull like bark, your breath mingling with the exhalations of the earth, that eternal smell of humus and mould.

## MESSAGE

With a body  
heavy as earth  
she begins to speak;

her words  
are dew, bright  
deadly to drink

her hair  
the damp mare's  
nest of the grass

her arms  
thighs, chance  
of a swaying branch

her secret  
message, shaped  
by a wandering wind

puts the eye  
of reason out;  
so novice, blind,

ease your  
hand into the  
rot smelling crotch

of a hollow  
tree, and find  
two pebbles of quartz

protected by  
a spider's web:  
her sunless breasts.

**For The Hillmother**

Hinge of silence

    creak for us

Rose of darkness

    unfold for us

Wood anemone

    sway for us

Blue Harebell

    bend for us

Moist fern

    unfurl for us

Springy moss

    uphold us

Branch of pleasure

Leaves of delight

    murmur for us

odorous wood

    breathe on us

Evening dews

    pearl for us

Freshet of ease

Secret waterfall

    pour for us

Hidden cleft

    speak to us

Portal of delight

    inflamm us

Hill of motherhood

    wait for us

Gate of birth

    open for us

---

First performance:

*22 October 1992, St Giles Church, Cripplegate, Barbican*

*New Macnaghten Concerts 1992 Season*

*Singcircle, Director Gregory Rose*

# A SLOW DANCE

## BACK

Michael Alcorn

$\text{♩} = 60$

tape

(VOCAL FRAGMENTS)...

(ssst...)

(csss...)

sop

alto

pp (sempre)

(m) (m)

ten

ppp (LONTANO)

(m)

bass

Detailed description: This system of the musical score includes five vocal staves (tape, sopranos, alto, tenors) and a bass staff. The tempo is marked as quarter note = 60. The tape part features two vocal fragments: '(ssst...)' and '(csss...)', both marked with a fermata. The alto part begins with a piano (*pp*) dynamic and a 'sempre' instruction, followed by a melodic line with two measures marked '(m)'. The tenor part begins with a pianissimo (*ppp*) dynamic and a 'LONTANO' instruction, followed by a melodic line with one measure marked '(m)'. The soprano and bass staves are currently empty.

tape

(we move)

(or bare)

(...lute to the sun disc)

[t] [t]

sop

alto

(m)

ten

(m)

bass

Detailed description: This system of the musical score includes five vocal staves (tape, sopranos, alto, tenors) and a bass staff. The tape part contains four vocal fragments: '(we move)', '(or bare)', '(...lute to the sun disc)', and '[t] [t]'. The alto part has a melodic line with one measure marked '(m)'. The tenor part has a melodic line with one measure marked '(m)'. The soprano and bass staves are currently empty.



0'24"

[ACCUMULATING VOICE FRAGMENTS]

tape

sop

alto

ten

bass

0'36"

tape

sop

alto

ten

bass

0'48"

tape

Musical staff for tape part, measures 1-3. The staff is empty.

sop

Musical staff for soprano part, measures 1-3. The staff is empty.

alto

Musical staff for alto part, measures 1-3. The staff contains a melodic line with eighth and quarter notes. There are three breath marks labeled '(m)' under the staff.

ten

Musical staff for tenor part, measures 1-3. The staff contains a melodic line with quarter and eighth notes. There are three breath marks labeled '(m)' under the staff.

bass

Musical staff for bass part, measures 1-3. The staff is empty.

1'00"

[SYNTHETIC GLOTTAL SOUNDS]

tape

Musical staff for tape part, measures 1-3. The staff is empty.

sop

Musical staff for soprano part, measures 1-3. The staff is empty.

alto

Musical staff for alto part, measures 1-3. The staff contains a melodic line with quarter and eighth notes. There are two breath marks labeled '(m)' under the staff.

ten

Musical staff for tenor part, measures 1-3. The staff contains a melodic line with quarter and eighth notes. There are two breath marks labeled '(m)' under the staff.

bass

Musical staff for bass part, measures 1-3. The staff is empty.

1'12"

VOCAL CHORD CRESCENDO

tape

sop

alto

ten

bass

1'24"

tape

sop

*pp sempre*

alto

*pp sempre*

ten

*pp sempre*

bass

*pp sempre*

1'36"

[CROTALE]

tape

Musical staff for tape part, showing a single note with a dynamic marking 'p' and a hairpin symbol.

sop

Musical staff for soprano part, including lyrics: EARTH WOMB WE MOVE. Features triplets and slurs.

alto

Musical staff for alto part, including lyrics: EARTH WOMB WE MOVE. Features triplets and slurs.

ten

Musical staff for tenor part, including lyrics: EARTH WOMB WE MOVE. Features triplets and slurs.

bass

Musical staff for bass part, including lyrics: EARTH WOMB WE MOVE. Features triplets and slurs.

1'48"

tape

Musical staff for tape part, showing a single note.

sop

Musical staff for soprano part, including lyrics: SLOW---LY BACK TO

alto

Musical staff for alto part, including lyrics: SLOW---LY BACK TO

ten

Musical staff for tenor part, including lyrics: SLOW---LY BACK TO

bass

Musical staff for bass part, including lyrics: SLOW---LY BACK TO

2'00"

tape

sop  
OUR OR GINS

alto  
OUR OR GINS

ten  
OUR OR GINS

bass  
OUR OR GINS

2'12"

tape

sop  
THE NA KED SAL

alto  
THE NA KED SAL

ten  
THE NA KED SAL

bass  
THE NA KED SAL

2'24"

tape

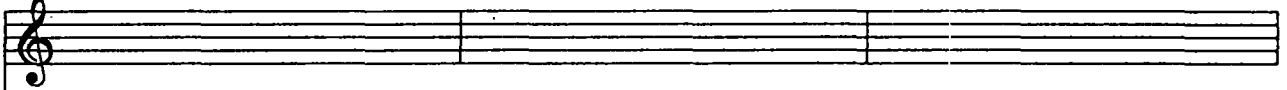

sop

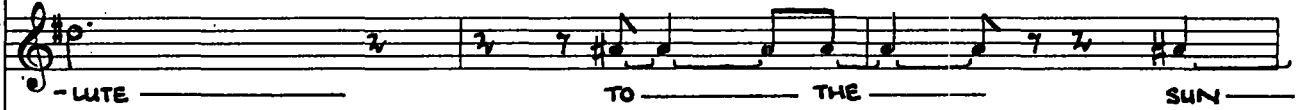

alto

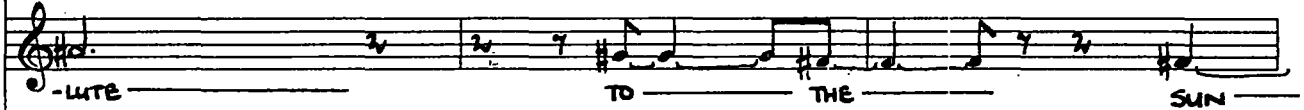

ten

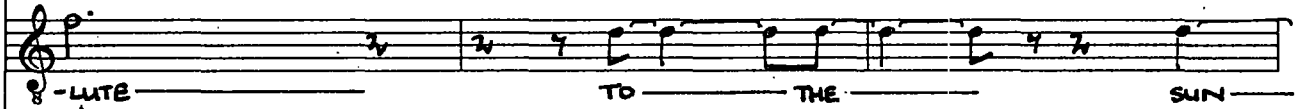

bass

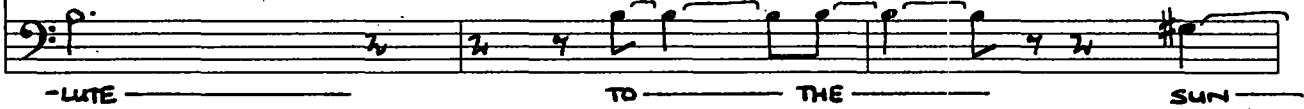

2'36"

tape

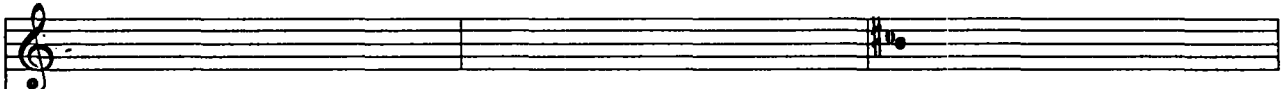

sop

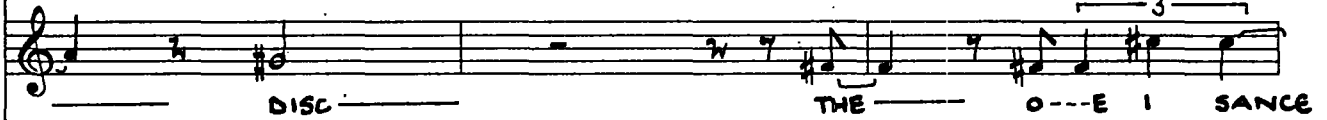

alto



ten



bass



2'48"

tape

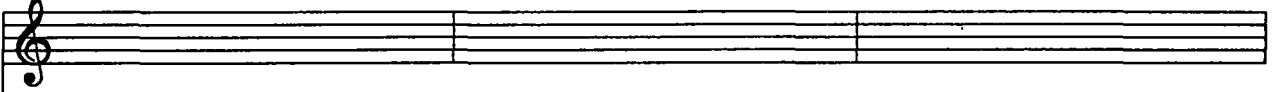

sop



alto



ten



bass

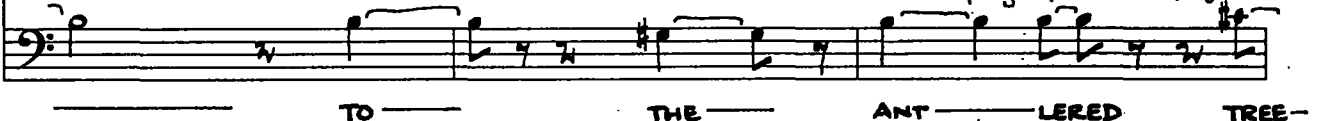

3'00"

tape

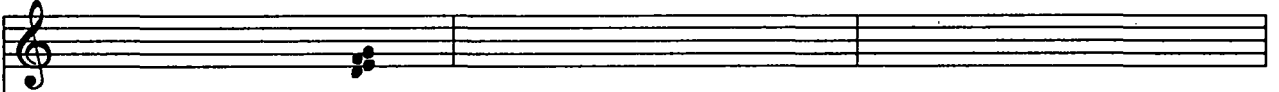

sop



alto



ten



bass



3'12"

tape

sop

alto

ten

bass

PPP

ON THE GRASS

ON THE GRASS

ON THE GRASS

ON THE GRASS

ON THE GRASS

3'24"

[E PITCH SUSTAINED]

3'32"

tape

sop

alto

ten

bass

pp



3'36"

3'43"

tape

sop

v.v.  
# molto marcato

EARTH EARTH DARKNESS CLOUDED MOON

alto

# molto marcato

EARTH EARTH DARKNESS CLOUDED MOON

ten

# molto marcato

EARTH EARTH DARKNESS CLOUDED

bass

# molto marcato

EARTH DARKNESS CLOUDED MOON

3'48"

tape

sop

MOON WHIRLING WHIRLING WHIRLING

alto

WHIRL WHIRLING WHIRLING WHIRLING ARMS

ten

MOON WHIRLING WHIRLING WHIRLING

bass

WHIRL WHIRLING WHIRLING WHIRLING

4'00"

tape

sop

ARMS — THEY SHUFFLE HAIR — HAIR — FLY — — — ING EYES

alto

ARMS — THEY — SHUFFLE HAIR — FLY — — — ING EYES

ten

ARMS THEY — SHUFFLE HAIR — FLY — — — ING — EYES

bass

THEY — HAIR — FLYING — EYES — FLASH —

4'12"

tape

[GLOTTAL CLICKS]

sop

FLASHING — IN — — — STEP — ECHOING — ONE — TWO — AS —

alto

IN — — — STEP — ECHOING — ONE — TWO — AS

ten

FLASHING — IN — — — STEP — TWO —

bass

— — — — — ING — IN — — — STEP — ONE — TWO —

4:24

[WHISPERING VOICES]

tape

sop

alto

ten

bass

BARE HEELS TOE SMITE (TE) THE EARTH

BARE AS BARE HEELS TOE SMITE

AS AS BARE HEELS TOE

AS BARE

4:36

[rall-phasing bass]

tape

sop

alto

ten

bass

BARE HEELS TOE

THE EARTH

SMITE THE EARTH THE

HEELS TOE THE

4'48" [crotale timbre]

tape

[GLOTTAL CLICKS]

sop

THE EARTH

alto

THE EARTH

ten

EARTH

bass

EARTH

5'00"

tape

sop

alto

ten

bass

# SESKILGREEN

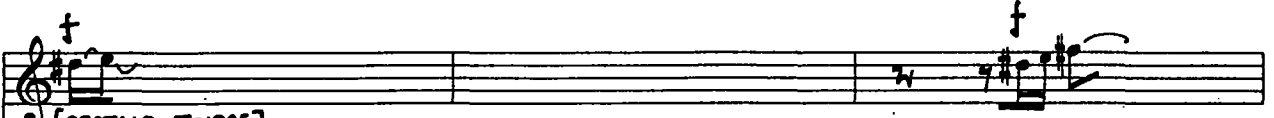
*tape*   
 [CROTALE - TIMBRE]  
 [5'14" ] [5'22" ]

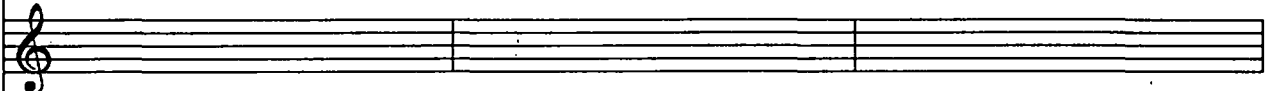
*sop* 

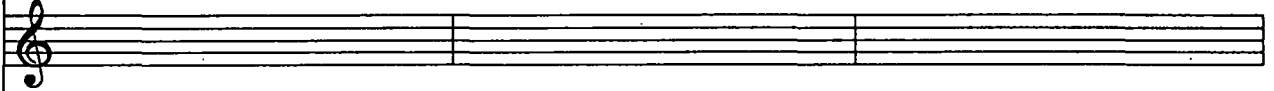
*alto* 

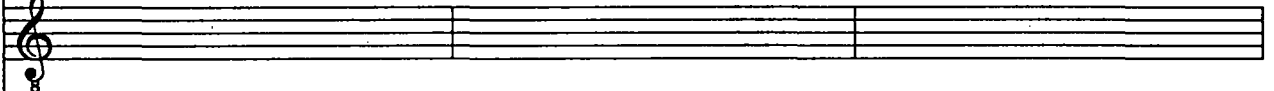
*ten* 

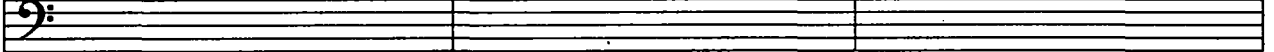
*bass* 

*tape*   
 [5'28" ]

*sop*   
 f (marcato)  
 A CIRCLE

*alto* 

*ten* 

*bass* 

tape

sop

OF STONES SURVIVING BE-HIND A GUTTERY FARM-HOUSE

alto

ten

bass

[5'46"]

tape

sop

THE CAPSTONE PHALIC IN A THISTLY MEADOW SES-KIL-GREEN

alto

ten

bass

[5'55"]

tape

sop

alto

ten

bass

[6'04"]

PASS--AGE GRAVE CUP CIR---CLE TRI--

CIR---CLE

CUP TRI---ANG-

tape

sop

alto

ten

bass

-ANGLE BEATING THEIR SE---CRET DANCE EYES BREASTS

BEA---TING DANCE EYES BREASTS

LE SE---CRET EYE

(m)

tape

[phasing] mp [cristale]

[6'38"]

sop

THIGHS OF A FRA-----GRANT GODDESS

alto

THIGHS OF A FRAG--GRANT GODD--ESS

ten

.....S BREAST(S) (S) THIGHS OF A FRAG-RANT GODDESS

bass

(m) (m) (m)

tape

sop

I CAME LAST IN MAY TO FIND THE MOUND DROWNED IN

alto

I CAME LAST IN MAY TO FIND THE MOUND DROWNED IN

ten

I CAME LAST IN MAY TO FIND THE MOUND DROWNED IN

bass



tape

sop  
 BLUE --- BELLS --- WITH A FEAR--- LESS WREN --- HOAR-DING

alto  
 BLUE --- BELLS --- WITH A FEAR--- LESS WREN --- HOAR-DING

ten  
 BLUE BELLS WITH

bass

tape

[7'11"]

sop  
 SPECK---LED EGGS --- IN A STONY CREVICE ---

alto  
 SPECK --- LED EGGS --- IN A STONY CREVICE ---

ten

bass

[7'25"]

[SYNTHETIC VOICE TEXTURE]

CONTINUES

tape

sop

alto

ten

bass

While cattle swayed sleepily

mp

P

(m)

3

3

3

(m)

(m)

(m)

3

3

3

(m)

(m)

tape

sop

alto

ten

bass

UN---DER LOW BRANCHES LASHING THE ROPES OF THEIR TAILS

(m)

3

3

3

(m)

(m)

(m)

3

3

3

(m)

(m)

(m)

tape

sop  
A - CROSS THE CE - - - NT - UR - IES

alto  
(m) (m)

ten  
THEIR TAILS A - CROSS THE CENTURIES

bass  
(m) (m)

(NO BREAK)

tape

sop

alto

ten

bass

# THE DANCE

[8'24"]  
[PHASE VOCODER SOUNDS]  
[FADES OUT]

tape

sop

alto

ten

bass

[CUE]

tape

sop

alto

ten

bass

Bass: The text should be spoken deliberately, and in an almost whispered voice at the start. The enunciation should gradually become fragmented and a little frenzied, mirroring the dark earthy qualities of the text.

tape [pvoc]  
 [8'50"]  
 sop  
 alto  
 ten PP [EXHALATION]  
 [NN]  
 bass [P]

IN SILENCE AND ISOLATION THE DANCE BEGINS. NO ONE IS MEANT TO WATCH

tape [pvoc]  
 sop [FF]  
 alto PP  
 [FF]  
 ten  
 bass

LEAST OF ALL YOURSELF.

HANDS FALL TO THE SIDES, THE HEAD

tape

sop **pp** [LOW PITCHED EXHALATION]  
 [AH]

alto **pp** [EXHALATION]  
 [TEE]

ten **pp** [EXHALATION]  
 [KA]

bass

LOLLS EMPTY, A BROKEN STALK, THE SHOES FALL AWAY FROM

tape

sop **p** [EXHALATION]  
 [SS]

alto **mf** SK— **p** [EXHALATION]  
 [SAH]

ten **mf** T— [LOW, SLOW, EXHALATION]  
 [AH]

bass

YOUR FEET, THE CLOTHES PEEL AWAY FROM THE SKIN, BODY RAGS

tape

sop

mf IN OUT TT-

SSS-

alto

mf IN [HA] P EXHALATION SSS

ten

P SSS-

bass

THE SIGHT HAS SLOWLY FADED FROM YOUR EYES, THAT SIGHT OF HABIT WHICH SEES

tape

sop

IN MP [EXHALATION] T- E

alto

ten

IN T- EH-

bass

NOTHING. YOUR EARS BUZZ A LITTLE BEFORE THEY RETREAT TO WHERE THE

[949"] [GRANULAR TEXTURE - UNPITCHED]

tape

sop [EXHALATION]  
[HA]

alto mf  
T-

ten mf FAST INHALE  
D-

bass

HEART PULSES, A SOFT DRUM.

THEN THE DANCE BEGINS, CLEANSING

CRESCENDO POCO A POCO

tape

sop mf IN OUT  
T-

alto f [EXHALE] FAST INHALE  
T- B-

ten f IN IN OUT  
A- T-

bass

HEALING. THROUGH THE BARE FOREHEAD, ALONG THE BONES OF THE FEET,



tape

sop *mfzp* [EXHALATION] *mf* IN OUT IN

alto *mfzp* [EXHALATION]

ten *mfzp* [EXHALATION] *mf* IN OUT IN

bass

THE EARTH BEGINS TO SPEAK. ONE KNEE LIFTS RUSTILY, THEN THE

tape

sop *mf* IN *mf* IN

alto *mf* IN *mf* IN

ten *mf* IN *mf* IN [EXHALATION]

bass CRESCENDO POCO A POCO...

OTHER. TOTALLY ABSENT, YOU SHUFFLE UP AND DOWN, THE PURSE

tape

sop

alto

ten

bass

[BUILDING IN INTENSITY]

OF YOUR LOINS STRIKING AGAINST YOUR THIGHS. FROM WHERE THE LEGS JOIN

tape

sop

alto

ten

bass

THE RHYTHM SPREADS UPWARDS - THE CAGE OF THE RIBS WHISTLING - TO PASS

1 Soprano, alto, tenor: continue fragmented texture of gasping & breathing sounds, consonants, vocal utterances and exhalations. Build gradually towards a complex stammering mass of sound by the end of the passage. Include any other short vocal sounds which you feel appropriate.

tape

sop

alto

ten

bass

mf

IN OUT

IN

IN

IN

SS

DA

T

NN

S

[BUILDING IN INTENSITY]

DOWN THE ARMS LIKE ELECTRICITY ALONG A WIRE. ON THE SKIN MOISTURE

tape

sop

alto

ten

bass

mf

IN OUT

CRESCENDO POCO A POCO

CRESCENDO POCO A POCO

CRESCENDO POCO A POCO

CRESCENDO POCO A POCO

FORMS, A WET LEAF OR A WINDBREATH LIGHT AS A MAYFLY. IN WET

tape

sop

CRESCENDO POCO A POCO

alto

CRESCENDO POCO A POCO

ten

[GRADUALLY BECOMING FRAGMENTED...]

bass

AND DARKNESS YOU ARE REBORN, THE RAIN FALLING ON YOUR FACE AS IT

tape

sop

alto

ten

bass

WOULD ON A MOSSY TREE TRUNK, WET HAIR CLINGING TO YOUR SKULL LIKE BARK,

tape

sop

alto

ten

bass

YOUR BREATH MINGUNG WITH THE EXHALATIONS OF THE EARTH, THAT ETERNAL

tape

sop

alto

ten

bass

[11'02"]

[WIND-LIKE SOUND]

P [WHISPER]

MOULD

P [WHISPER]

MOULD

P [WHISPER]

MOULD

SMELL OF HUMUS AND MOULD...

**ff** *pvoc* [11'26"]

tape [11'12"] [11'13"] [TAPES:] WITH A BODY HEAVY AS EARTH

sop *f* *(mm) sempre*

alto *f* *(mm) sempre* *molto vib* *senza* (b)

ten *f* *(mm) sempre*

bass *f* *(mm) sempre*

tape SHE BEGINS TO SPEAK ; HER WORDS ARE DEW, BRIGHT DEADLY TO DRINK

sop *molto vib*

alto *molto vib* *senza*

ten *molto vib* *senza*

bass *molto vib* *senza*

[11'41"]

tape

HER HAIR THE DAMP MARE'S NEST OF GRASS. HER ARMS, THIGHS

senza

molto vib senza

molto vib senza

Detailed description: This system contains five vocal staves. The 'tape' staff is a treble clef with lyrics. The 'sop' staff is a soprano clef with a key signature of one flat. The 'alto' staff is an alto clef with a key signature of one flat. The 'ten' staff is a tenor clef with a key signature of one flat. The 'bass' staff is a bass clef with a key signature of one flat. Performance markings include 'senza' (without vibrato) and 'molto vib' (much vibrato) with slanted lines indicating the duration of each effect.

CHANCE OF A SWAYING BRANCH. HER SECRET MESSAGE, SHAPED BY A

molto vib senza

molto vib senza

molto vib senza

molto vib senza

molto vib senza

Detailed description: This system continues the vocal parts from the first system. It features the same five vocal staves. The lyrics are 'CHANCE OF A SWAYING BRANCH. HER SECRET MESSAGE, SHAPED BY A'. Performance markings include 'molto vib' and 'senza' with slanted lines indicating the duration of each effect. There are also some accent marks (>) above certain notes in the soprano, alto, and bass parts.

[11'57" ]

tape

WANDERING WIND PUTS THE EYE OF REASON OUT; SO NOVICE, BLIND

sop

molto vib senza

molto vib senza

molto vib senza

molto vib senza

molto vib senza

molto vib senza

molto vib senza

tape

EASE your HAND INTO THE ROT SMELLING CROTCH OF A HOLLOW TREE

sop

molto vib senza

molto vib senza

molto vib senza

molto vib senza

molto vib senza

molto vib senza



[12'15"]

tape

AND FIND TWO PEBBLES OF QUARTZ. PROTECTED BY A SPIDER'S WEB :

sop

alto

ten

bass

tape

HER SUNLESS BREASTS .

sop

alto

ten

bass

# FOR THE HILLMOTHER

$\text{♩} = 60$

[LOW 'BASS DRUM' TIMBRE]

tape

$\text{♩}$  *v.v.*

$\text{♩}$  *v.v.*

sop

$f$   
[13'00"]

[13'10"]

alto

ten

bass

*mp* (LEGATO)

HIN

tape

sop

alto

ten

bass

$\text{♩}$  *v.v.*

[13'23"]

BE OF SI - - - - - LENCE CREAK FOR US

tape

sop

alto

ten

bass

*mp*

ROSE ROSE OF DARKNESS

tape

sop

alto

ten

bass

[13'40"] [13'45"]

$\text{B}_{\text{w}}$   $\text{B}_{\text{w}}$

*p* *mf*

CREAK FOR US WOOD

CREAK FOR US WOOD

[13'59" ]

tape

sop

alto

ten

bass

A -- NEM -- -- -- O -- NE SWAY -- FOR US

[14'02" ]

tape

sop

alto

ten

bass

BLUE HARE --- BELL

[14'18"]

tape  $\text{E} \text{ } \text{v.v.}$

sop *mf*  $\text{3}$   $\text{3}$   $\text{3}$   
 MOIST — FERN — UN —

alto *mf*  
 BEND — TD — US — MOIST — FERN — UN —

ten *mf*  
 BEND — TD — US — MOIST — FERN — UN —

bass *mf*  
 BEND — TD — US — MOIST — FERN — UN —

[14'26"] [14'32"]

tape  $\text{E} \text{ } \text{v.v.}$   $\text{E} \text{ } \text{v.v.}$

sop *mf*  $\text{3}$   $\text{3}$   $\text{3}$   
 FURL — FOR US — SPRIN — — — GY — MOSS —

alto *mf*  
 FURL — FOR US — SPRIN — — — GY — MOSS —

ten *mf*  
 FURL — FOR US — UP — — HOLD — — — US —

bass *mf*  $\text{3}$   
 FURL — FOR US — UP — — HOLD — — — US —

[14'46"]

tape

sop

alto

ten

bass

Handwritten musical score for the first system. It includes a tape track, vocal parts for soprano, alto, tenor, and bass, and piano accompaniment. The lyrics are: "BRANCH OF PLEASURE LEAVES". The score features dynamic markings such as *mf*, *p*, and *pmf*, and includes triplet markings. A tempo or rehearsal mark "[14'46"] is present at the top right.

tape

sop

alto

ten

bass

Handwritten musical score for the second system. It includes a tape track, vocal parts for soprano, alto, tenor, and bass, and piano accompaniment. The lyrics are: "MUR MUR FOR US" and "OF DELIGHT MURMOR FOR US". The score features dynamic markings such as *mf* and *p*, and includes triplet markings.

[15'01"]

[15'09"]  
ppp [DISTANT VOICE SOUNDS]

tape

♯ *v.v.*

sop *mp* *p*  
OD--OR---OUS WOOD BREATHE ON US

alto *mp* *p*  
OD--OR---OUS WOOD BREATHE ON US

ten *p*  
BREATHE ON US

bass *p*  
BREATHE ON US

[15'34"]

tape

♯ *v.v.*

sop *mf*  
EVE-----NING

alto *mf*  
EVE-----NING

ten *mf*  
EVE-----NING

bass *mf*  
EVE-----NING

15'27" [VOICE TEXTURE]

tape

sop  
 DEWS PEARL FOR US FRESH --- ET OF EASE

alto  
 DEWS PEARL FOR US FRESH --- ET OF EASE

ten  
 DEWS FRESH --- ET OF EASE

bass  
 DEWS FRESH --- ET OF EASE

tape

sop  
 SE --- CRET WA --- TER FALL

alto  
 SE --- CRET WA --- TER FALL

ten  
 SE --- CRET WA --- TER FALL

bass  
 SE --- CRET WA --- TER FALL



tape

sop *p sempre*  
SPEAK TO US IN--

alto *p sempre*  
POUR FOR US SPEAK TO US IN--

ten [SOLO] *sempre*  
POUR FOR US HI-- DEN CLEFT POR TAL--

bass *p sempre*  
POUR FOR US SPEAK TO US IN--

tape

sop  
FLAME US WAIT FOR US

alto  
FLAME US WAIT FOR US

ten  
OF DE--LIGHT HILL OF MOTHERHOOD

bass  
FLAME US WAIT FOR US

tape ppp [16'23"]  
[LOW GLOTTAL CLICKS]  
 ♪ w.

sop p ————— ppp  
 OP - - - - EN ——— FOR US

alto p ————— ppp  
 OP - - - - EN ——— FOR US

ten p ————— ppp  
 3  
 GATE OF BIRTH

bass p ————— ppp  
 OP - - - - EN ——— FOR US

tape [16'30"]                      [16'40"]                      [16'52"]  
 ♪                      ♪                      ♪

sop  
 alto  
 ten  
 bass

# *Perichoresis*

*Michael Alcorn*  
1990

*Commissioned by the Belfast Music Society to celebrate their 70th season, with Funds provided by the Arts Council of Northern Ireland.*

*First performance by the Nash Ensemble  
University of Ulster at Coleraine, 10 October 1990*



## Instrumentation

### WIND QUINTET -

Solo Oboe

Flute (doubling piccolo)

Clarinet (B Flat)

Horn (doubling G sharp antique cymbal)

Bassoon (doubling Fsharp antique cymbal)

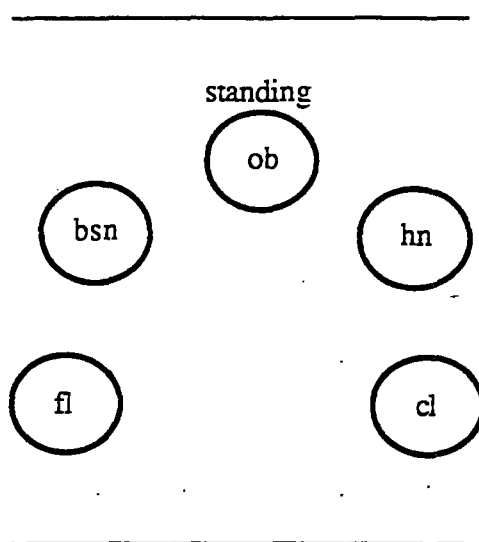

## Programme Note

Two ideas were important in my mind from the early stages of writing this piece. Firstly, to create an imaginary ballet with musical ideas suggesting movement, dance and drama. Secondly, to de-stabilise the wind quintet by featuring one of the instruments as a principle voice. This role is taken by the oboist, whose function is to initiate, develop and disseminate musical material to the remaining instruments.

Throughout the work the position of the oboe is constantly challenged; gradually its untethered musical lines become constrained and integrated into the ensemble.

Much of the inspiration for the work is drawn from the title, a chance discovery, which helped forge many of the musical ideas. *Perichoresis* means going around, rotating, transferring to, to come to in succession. Other Greek words which are linked to the work are *Choreutes*: to dance, *Chori*: to tear asunder, wrench apart, and, with regard to the role of the oboe within the quintet, *Choragus*: the name given to the leader of the chorus in Greek Drama.

# Perichoresis

for wind quintet

Michael Alcorn

$\text{♩} = 72$

1

Oboe

Flute

Clarinet

Horn

Bassoon

*p*

*p*

[Sotto Voce]

*ppp*

*ppp*

*ppp*

ANTIQUE CYMBAL

*p* l.v.

ANTIQUE CYMBAL

*p* l.v.

Oboe

Flute

Clarinet

Horn

Bassoon

*pp*

*p*

*ppp*

Oboe

Flute

Clarinet

Horn

Bassoon

*p*

*p*

*ppp*

*p*

Oboe

Flute

Clarinet

Horn

Bassoon

*pp*

*ppp*

*p*

**A** piu mosso [ $\text{♩} = 076$ ]

13

Oboe *p*

Clarinet *pp*

Horn *p* *w.* [sempre]

Bassoon *p* *w.* [sempre]

16

Oboe *mp* *pp* *p*

Flute *pp* *p* *mf*

Clarinet *pp*

Horn

Bassoon

19

Oboe *mp* *mf*

Flute *mf* *p* *mf* *mp*

Clarinet *mp*

Horn *l.v.*

Bassoon *l.v.*

22

Oboe *pp* *mf* *f*

Flute *mf* *f*

Clarinet *pp* *mf* *f*

Horn *f*

Bassoon *f*

**B**



25

Oboe

Flute

Clarinet

Horn

Bassoon

This musical score block covers measures 25 through 28. It features three staves: Oboe, Flute, and Clarinet. The Oboe part begins at measure 25 with a dynamic of *f* and includes several triplet markings. The Flute part starts at measure 26 with a dynamic of *mf* and contains triplet and sextuplet markings. The Clarinet part also begins at measure 26 with a dynamic of *mf* and includes a *pp* marking. The Horn and Bassoon staves are present but contain no musical notation in this section.

28

Oboe

Flute

Clarinet

Horn

Bassoon

This musical score block covers measures 28 through 31. It features three staves: Oboe, Flute, and Clarinet. The Oboe part continues from measure 28 with a dynamic of *mf* and includes a *stacc* marking. The Flute part continues from measure 28 with a dynamic of *mf* and includes a *stacc* marking. The Clarinet part continues from measure 28 with a dynamic of *mf* and includes a *stacc* marking. The Horn and Bassoon staves are present but contain no musical notation in this section.

C piu mosso [ $\text{♩} = \text{c80}$ ]

Oboe 31 *f* *GLISS.*

Flute *f*

Clarinet *f*

Horn *f* w.v. **TO HORN**

Bassoon *f* w.v. **TO BASSOON**

Oboe 34 *mf* [sempre]

Flute *mf* [sempre]

Clarinet *mf* [sempre]

Horn *pp* *mf*

Bassoon *pp* *mf*

37

Oboe (mf) *tr* *GLISS*

Flute (mf)

Clarinet (mf)

Horn (mf)

Bassoon (mf)

40

Oboe **D** *tr*

Flute *stz*

Clarinet *mf* *f*

Horn *p* *f* *p*

Bassoon *p* *f*

43

Oboe

Flute

Clarinet

Horn

Bassoon

46

Oboe

Flute

Clarinet

Horn

Bassoon

Oboe

Flute

Clarinet

Horn

Bassoon

Piu Mosso  $\text{♩} = c 88$

**E** marcato (tutti)

Oboe

Flute

Clarinet

Horn

Bassoon



61

Oboe

Flute

Clarinet

Horn

Bassoon

61

[tr]

sfz sfz

3

sfz

[tr]

sfz sfz

tr

sfz mf

[tr]

sfz sfz

3

tr

sfz mf

tr

3

tr

sfz mf

[tr]

sfz

3

sfz mf

64

Oboe

Flute

Clarinet

Horn

Bassoon

64

[tr]

sfz sfz

f

[tr]

sfz sfz

sfz

f

[tr]

sfz sfz

f

[tr]

sfz sfz

sfz

f

[tr]

sfz sfz

f

G

67

Oboe

Flute

Clarinet

Horn

Bassoon

70

Oboe

Flute

Clarinet

Horn

Bassoon



H

SENZA MISURA

73

Oboe

Flute

Clarinet

Horn

Bassoon

*mf*

*tr*

*mf*

*mf*

*molto legato*

*mf*

74

Oboe

Flute

Clarinet

Horn

Bassoon

*rall poco a poco*

*rall poco a poco*

*rall poco a poco*

Oboe

Flute

Clarinet

Horn

Bassoon

*rall poco a poco*

*rall poco a poco*

Detailed description: This block contains the first system of a musical score for five woodwind instruments. From top to bottom, the staves are labeled Oboe, Flute, Clarinet, Horn, and Bassoon. The Oboe and Flute staves are empty. The Clarinet and Horn staves contain musical notation with the instruction "rall poco a poco" written above them. The Bassoon staff contains a few notes at the beginning of the system.

Oboe

Flute

Clarinet

Horn

Bassoon

LUNGA

Detailed description: This block contains the second system of the musical score. The Oboe and Flute staves are empty. The Clarinet staff contains musical notation with the instruction "LUNGA" written above it. The Horn and Bassoon staves contain a few notes.

# Movement II

$\text{♩} = \text{ca } 60$

**SENZA MISURA**



Oboe

*mf* [with expression]

Flute

Clarinet

*pp*

Horn

*pp*

Bassoon

*pp*

Oboe

Flute

Clarinet

Horn

Bassoon

Oboe

Flute

Clarinet

Horn

Bassoon

2

Oboe

Flute

Clarinet

Horn

Bassoon

Oboe

Flute

Clarinet [Breathe quickly where necessary]

Horn [Breathe quickly where necessary]

Bassoon [Breathe quickly where necessary]

Oboe

Flute

Clarinet

Horn

Bassoon

Oboe *tr* **[pp]**

Flute

Clarinet

Horn

Bassoon

**A**  $\text{♩} = \text{♩} 52$

1 Oboe **pp** **f**

Flute **pp**

Clarinet **pp** 3 3

Horn *str*

Bassoon *str*

4

Oboe

Flute

Clarinet

Horn

Bassoon

pp

7

Oboe

Flute

Clarinet

Horn

Bassoon

pp

10 **B**

Oboe

Flute

Clarinet

Horn

Bassoon

pp

pp

[rasping]

[rasping]

pp

pp

13

Oboe

Flute

Clarinet

Horn

Bassoon

mf

p

pp

pp



16

Oboe

Gliss

mp

Flute

Clarinet

Horn

[rasping]

mp

Bassoon

[rasping]

mp

19

Oboe

Accelerando poco a poco

Flute

mf

Clarinet

mf

Horn

mf

Bassoon

mf

Accelerando

C

Oboe 22 *GLISS*

Flute

Clarinet 3 3 3

Horn +

Bassoon

\* USE ALL AVAILABLE ALTERNATIVE FINGERINGS

Accelerando

Oboe 25 *molto marcato* 3 5 5

Flute 3 3

Clarinet 3 3 3

Horn *molto marcato* 3 5 5

Bassoon

28  $\text{♩} = 92$

Oboe

Flute

Clarinet

Horn

Bassoon

MOLTO RALL

31

Oboe

Flute

Clarinet

Horn

Bassoon

Loco

34

Oboe

Flute

Clarinet

Horn

Bassoon

**D**

37  $\downarrow = ca 54$

Oboe

Flute

Clarinet

Horn

Bassoon

*pp sempre*

*pp sempre*

E

$\text{♩} = ca 48$

41

Oboe

pp sempre

Flute

pp sempre

Clarinet

pp sempre.

Horn

pp sempre

Bassoon

pp sempre

45

Oboe

Flute

Clarinet

Horn

Bassoon

49

Oboe

Flute

Clarinet

Horn

Bassoon

53

Oboe

Flute

Clarinet

Horn

Bassoon

57

Oboe

Flute

Clarinet

Horn

Bassoon

ppp

ppp

60

# Movement III

$\text{♩} = ca 84$

Musical score for measures 1-4, featuring five staves: Oboe, Flute, Clarinet, Horn, and Bassoon. The Oboe, Flute, and Bassoon parts begin with a dynamic marking of *sfz* (sforzando) and a breath mark (v). The Flute and Oboe parts have a *pp* (pianissimo) marking at the start of measure 2. The Clarinet and Horn parts have *sfz* markings throughout. The Bassoon part has a *pp* marking at the start of measure 4.

Musical score for measures 5-8, featuring five staves: Oboe, Flute, Clarinet, Horn, and Bassoon. Measure 5 is marked with a '5'. The Oboe part has *sfz* markings in measures 5 and 6, and *pp* markings in measures 7 and 8. The Flute part has *sfz* markings in measures 5 and 6, and *pp* markings in measures 7 and 8. The Clarinet part has *sfz* markings in measures 5 and 6, and *pp* markings in measures 7 and 8. The Horn part has *sfz* markings in measures 5 and 6, and *pp* markings in measures 7 and 8. The Bassoon part has *sfz* markings in measures 5 and 6, and *pp* markings in measures 7 and 8.



9

Oboe

Flute

Clarinet

Horn

Bassoon

This musical score covers measures 9 through 12. It features five staves: Oboe, Flute, Clarinet, Horn, and Bassoon. The Oboe part begins with a dynamic marking of *sfz* and includes a *pp* marking in measure 10. The Flute part also starts with *sfz* and has a *pp* marking in measure 10. The Clarinet part begins with *pp* and includes *sfz* markings. The Horn part starts with *pp* and includes *sfz* markings. The Bassoon part begins with *sfz* and includes *pp* markings. The score includes various dynamic markings such as *sfz*, *pp*, and *ppp*, along with accents and slurs.

13

Oboe

Flute

Clarinet

Horn

Bassoon

A

This musical score covers measures 13 through 16. It features five staves: Oboe, Flute, Clarinet, Horn, and Bassoon. A section marker 'A' is placed above the Oboe staff at the beginning of measure 13. The Oboe part starts with *pp* and includes *sfz* markings. The Flute part begins with *pp* and includes *sfz* markings. The Clarinet part starts with *pp* and includes *sfz* markings. The Horn part begins with *pp* and includes *sfz* markings. The Bassoon part starts with *pp* and includes *sfz* markings. The score includes various dynamic markings such as *pp*, *sfz*, and *ppp*, along with accents and slurs.

17

Oboe

Flute

Clarinet

Horn

Bassoon

pp mp pp sfz

pp mp pp sfz

pp mp pp

21

Oboe

Flute

Clarinet

Horn

Bassoon

pp pp

pp pp pp ppp

pp ppp ppp

pp pp

pp pp

STOP IMMEDIATELY WITH  
TUTTI CHORD

25

Oboe

Flute

Clarinet

Horn

Bassoon

SENZA MISURA [FLUTE]

**B**

1 [4"] [molto legato]

2 [3"] [FLUTE]

3 [5"] [FLUTE]

Oboe

Flute

Clarinet

Horn

Bassoon

(FLUTE) 4 [6"]

Oboe

Flute [molto legato] pp

Clarinet p pp

Horn p

Bassoon p

(FLUTE) 5 [5"]

Oboe

Flute [echo] pp mf p

Clarinet pp mf

Horn [echo] pp mf

Bassoon [echo] pp mf

(FLUTE) 6 [4"]

[FLUTE] 7 [4<sup>th</sup>]

[FLUTE] 8 [5<sup>th</sup>]

[BASSOON GIVES UPBEAT TO 9]

Oboe

Flute

Clarinet

Horn

Bassoon

[BASSOON] 9 [3<sup>rd</sup>]

[BASSOON] 10 [2<sup>nd</sup>]

[BASSOON] 11 [4<sup>th</sup>]

Oboe

Flute

Clarinet

Horn

Bassoon

[BASSOON]  
12 [10<sup>th</sup>]

Oboe

Flute

Clarinet

Horn

Bassoon

**\* HORN + BASSOON SYNCHRONIZE EXACTLY**

Oboe

Flute

Clarinet

Horn

Bassoon

[FLUTE]  
13 [8°]

Oboe

Flute

Clarinet

Horn

Bassoon

[FLUTE]  
14 [8°]

Oboe

Flute

Clarinet

Horn

Bassoon

SYNCHRONIZE EXACTLY WITH BSN

SYNCHRONIZE EXACTLY WITH HORN

[HORN]  
15

Oboe

Flute

Clarinet

Horn

Bassoon

[HORN] 16  $\text{♩} = 192$   
Sempre marcato

Oboe

Flute

Clarinet

Horn

Bassoon



31

Oboe

Flute

Clarinet

Horn

Bassoon

34

Oboe

Flute

Clarinet

Horn

Bassoon

38

Oboe

Flute

Clarinet

Horn

Bassoon

VALVE TREM.

44

Oboe

Flute

Clarinet

Horn

Bassoon

45

Oboe

Flute

Clarinet

Horn

Bassoon

49

Oboe

Flute

Clarinet

Horn

Bassoon

TO PICCOLO

54

Oboe

Flute

Clarinet

Horn

Bassoon

56

Oboe

Flute

Clarinet

Horn

Bassoon

59

Oboe

Flute

Clarinet

Horn

Bassoon

67

**SENZA MISURA**

17

Oboe

Flute

Clarinet

Horn

Bassoon

(picc)  
9

Oboe

Flute

Clarinet

Horn

Bassoon

Musical score for five instruments: Oboe, Flute, Clarinet, Horn, and Bassoon. The score is written on five staves. The Oboe staff has a treble clef and a key signature of one sharp (F#). The Flute, Clarinet, and Horn staves have treble clefs and a key signature of one sharp (F#). The Bassoon staff has a bass clef and a key signature of one sharp (F#). The music is in common time (C). The Oboe part begins with a melodic line, followed by a rest. The Flute part begins with a melodic line, followed by a rest. The Clarinet, Horn, and Bassoon parts begin with a melodic line, followed by a rest. The music then continues with a series of notes and rests, including dynamic markings such as *sfz* and *ffz*. A handwritten annotation "(picc)" with a downward arrow and the number "9" is positioned above the Oboe staff. The score is enclosed in a double-line box.

**Making a Song and Dance . . .**

**for**

**violin, clarinet, 'cello and piano**

**MICHAEL ALCORN**

**1989**

Commissioned by the 1989 Sonorities Festival of 20th Century Music.

First performance given by Sequenza at Sonorities in April 1989  
Harty Room at Queen's University.



MAKING A SONG AND DANCE.....

$\text{♩} = 144$

vn

cl

vc

8va

pno

*p* *ppp* [ALMOST INAUDIBLE] *sim*

$\frac{1}{2}$  ped u.c. SEMPRE

5

vn

cl

vc

8va

pno

$\frac{1}{2}$  ped u.c.



9

vln

cl

vc

pno

ppp sempre [almost inaudible]

$\frac{1}{2}p$   
u.c.

SEMPRE

14

vln

cl

vc

pno

$\frac{1}{2}$  ped  
u.c.

19 pizz

vin

cl

vc

pno

p

ppp

LOCO

1/4 ped

24

vin

cl

vc

pno

pp

mp

29

vin

cl

Vc

pno

[ARCO]

LONG!

$\frac{1}{2}p$   
uc.

**A** [HARD AND VERY RHYTHMICAL]

34

vin

cl

Vc

pno

39

vln

cl

vc

pno

Handwritten musical score for measures 39-43. The score is for Violin (vln), Clarinet (cl), Violoncello (vc), and Piano (pno). It features complex rhythmic patterns with many slurs and accents. Dynamic markings include sfz and mp. The piano part has a dense texture with many notes and slurs.

44

vln

cl

vc

pno

**B**

tr

tr

f

f

P [subito]

ffz

P [sempre]

tr

mf

P [subito] [sempre stacc]

w.v.

w.v.

1/2 ped.

Handwritten musical score for measures 44-48, starting with section B. The score is for Violin (vln), Clarinet (cl), Violoncello (vc), and Piano (pno). It features complex rhythmic patterns with many slurs and accents. Dynamic markings include f, P [subito], ffz, P [sempre], mf, P [subito] [sempre stacc], and 1/2 ped. The piano part has a dense texture with many notes and slurs.

49

vln

cl

vc

pno

54

vln

cl

vc

pno

59

vln

cl

vc

pno

8va

64

vln

cl

vc

pno

LONG

sul pont. tr

sfz

ff

6  
16

69

Violin (vln), Clarinet (cl), Violoncello (vc), and Piano (pno) staves. The music is in 6/16 time. The key signature has two sharps (F# and C#). The score includes various musical notations such as slurs, accents, and dynamic markings.

*poco a poco rall. . . . .*

74

Violin (vln), Clarinet (cl), Violoncello (vc), and Piano (pno) staves. The music continues from the previous page. It features dynamic markings such as *sfz* (sforzando) and *f* (forte), and includes the instruction *poco a poco rall. . . . .* (poco a poco rallentando). The notation includes slurs and accents.

79

vln

cl

vc

pno

♩ = 69

mp

p

84

vln

cl

vc

pno

♩ = 69

p

mp

[pizz]



89

vln

mf

p

[BELL-LIKE]

f

cl

[BELL-LIKE]

f

Vc

[Arco]

[pizz]

f

sfz

pno

[BELL-LIKE]

f

lv.

(7) (7)

94

vln

cl

Vc

pno

f

f

f

lv.

(7) (7) (7)

(7) (7) (7)

(7) (7) (7)

2  
8

2  
8

**F**  $\text{♩} = 72$   
*piu mosso*

Violin (vln) and Viola (vc) parts with dynamic markings *sfz* and *mf*. The Viola part includes *[pizz]* and *[ARCO]* markings.

Piano (pno) part with dynamic markings *sfz* and *mf*. Includes the instruction *8va basso*.

SLOWER  
**[BELL-LIKE]**

Violin (vln) and Viola (vc) parts with dynamic markings *f* and *sfz*. The Viola part includes *[BELL-LIKE]* and *SLOWER* markings.

Piano (pno) part with dynamic markings *sfz* and *f*. Includes circled numbers (7) and (9) in the bass line.

piu mosso  $\text{♩} = 68-76-80$

109

Handwritten musical score for measures 109-113. The score is for five instruments: Violin (vln), Clarinet (cl), Viola (vc), Piano (pno), and Bassoon (BASS). The key signature has one sharp (F#). The tempo is marked 'piu mosso' with a metronome marking of quarter note = 68-76-80. The score includes dynamic markings such as sfz, mf, and f. Performance instructions include 'pizz' (pizzicato) and 'ARCO' (arco). The violin part has 'BASS' written above it in some measures. The piano part has a complex texture with many notes.

114

Handwritten musical score for measures 114-118. The score is for five instruments: Violin (vln), Clarinet (cl), Viola (vc), Piano (pno), and Bassoon (BASS). The key signature has one sharp (F#). The tempo is marked 'piu mosso'. The score includes dynamic markings such as sfz, mf, and f. Performance instructions include 'pizz' and 'ARCO'. A circled 'G' is written above the violin staff in measure 114. The piano part has a complex texture with many notes. The bassoon part has 'BASS' written above it in some measures.

119

vln

cl

vc

pno

**ff [marcato]**

Musical score for measures 119-123. The score is for violin (vln), clarinet (cl), viola (vc), and piano (pno). The key signature has one sharp (F#). The tempo/mood is marked **ff [marcato]**. The violin part has a melodic line with accents. The clarinet part has a similar melodic line. The viola part features a triplet of eighth notes. The piano part has a complex accompaniment with triplets in the right hand.

124

vln

cl

vc

pno

*poco a poco rall*

8va

Musical score for measures 124-128. The score is for violin (vln), clarinet (cl), viola (vc), and piano (pno). The key signature has one flat (Bb). The tempo/mood is marked *poco a poco rall*. The violin part has a melodic line with accents. The clarinet part has a similar melodic line. The viola part features a triplet of eighth notes. The piano part has a complex accompaniment with triplets in the right hand and an *8va* marking in the left hand.



A tempo ♩ = ca 80

129

vln

cl

vc

pno

A tempo ♩ = ca 80

134

vln

cl

vc

pno

rall poco a poco

8va - rall poco a poco

$\text{♩} = 68-72$

139

**I**

vln

pp subito

3

3

cl

6

pp subito

3

3

vc

pno

LOCO

6

$\text{♩} = 68-72$

2/4

f

pp

pp

143

vln

3

3

3

cl

3

meno

3

3

vc

pp

p

pp

pno

6

Bva

147

vln

mp

3

3

3

cl

vc

12

15

pno

mp

151

vln

3

3

cl

vc

12

15

pno

(7)

155

J

violin (vln) staff: empty.

clarinet (cl) staff: *[very still]*, *pp*, triplet markings (3).

viola (vc) staff: *[very still]*, *pp*.

piano (pno) staff: *pp*, *h.v.* markings.

159

violin (vln) staff: empty.

clarinet (cl) staff: melodic line.

viola (vc) staff: melodic line.

piano (pno) staff: *pp*, *h.v.* markings.



163 **K**

vln *pp*

cl

vc *pp*

pno *pp*

166

vln *pp*

cl

vc

pno *MD*

♩ = ca 80

169

vln

cl

ve

pno

pp [sempre]

[pizz]

pp [sempre]

♩ = ca 80

Bra

Loco

173

vln

cl

ve

pno

178

vln

cl

vc

pno

[♩=♩] [M]  
 3 ♩ = ca 80  
 4

183

vln

cl

vc

pno

♩ = ca 80

3  
4

p

187

vln

cl

Vc

pno

191

vln

cl

Vc

pno

195

vin

cl

vco

pno

*mp*

*crescendo poco a poco*

[arco]

*mp*

199

vin

cl

vco

pno

*poco a poco accel.*

*sfz sfz marcato*

*ff ff marcato*

203

vln

cl

Vc

pno

207

vln

cl

Vc

pno

$\text{♩} = 144$

210

vln

cl

Vc

pno

This system of music covers measures 210 to 212. The violin (vln) part features a melodic line with a triplet of eighth notes in measure 210 and a slur over measures 211 and 212. The clarinet (cl) part mirrors the violin's triplet and includes sixteenth-note passages in measures 211 and 212, marked with *sfz*. The viola (Vc) part has a single note in measure 210 and a *sfz* marking in measure 211. The piano (pno) part consists of sixteenth-note chords in the right hand and eighth-note chords in the left hand, with sixteenth-note groupings marked with '6' above the staff.

213

vln

cl

Vc

pno

This system of music covers measures 213 to 215. The violin (vln) part has accents (>) on notes in measure 213 and a triplet in measure 214. The clarinet (cl) part has accents on notes in measure 213 and a sixteenth-note passage in measure 214. The viola (Vc) part has accents on notes in measure 213 and a sixteenth-note passage in measure 214. The piano (pno) part continues with sixteenth-note chords in the right hand and eighth-note chords in the left hand, with sixteenth-note groupings marked with '6' above the staff.



216

vln

mp

3

3

cl

*sfz*

6

*sfz*

6

mp

3

3

Vc

*b.*

mp [sub]

pno

6

6

6

6

6

6

6

6

MP

219

vln

3

cl

3

3

6

Vc

pno

6

6

6

6

6

6

6

6



222

vln

cl

Vc

pno

225

vln

cl

Vc

pno

228 **Q** with five! *decel....*

vln

cl

vc

pno

*with five!* *decel...*

*6* *6* *accel...* *h.v.* *h.v.*

231

vln

cl

vc

pno

*6* *mp* *ff* *(ff)*

**R**

*molto rit....*

*A tempo*

234

vin

cl

vc

pno

*ff molto marcato*

*mp*

*ff molto marcato*

*ff molto marcato*

238

vin

cl

vc

pno

*[x4]*

*[x4]*

*[x4]*

*[x4]*

violin (vln) and piano (pno) staves. The music is in 2/8 time, indicated by a large '2' over an '8'. The key signature has one sharp (F#). The violin part features a melodic line with many slurs and accents. The piano accompaniment consists of rhythmic patterns in both hands, with a large '2' over an '8' in the right hand.

violin (vln), clarinet (cl), and piano (pno) staves. The music is in 3/8 time, indicated by a large '3' over an '8'. The key signature has one sharp (F#). The violin and clarinet parts have long slurs and accents, with the instruction 'piu mosso' (more slow) written above the violin staff. The piano accompaniment includes a triplet in the right hand and a five-note fingering (5) in the left hand. The instruction 'l.v.' (left hand) is written near the bottom of the piano staff.

*molto accel...*

250

violin (vln) and piano (pno) staves. The piano part includes the instruction *molto accel....* and a triplet of eighth notes. The violin part has a measure marked 816 with a dashed line extending to the right.

$\dot{=} \dot{=} \dot{!}$   
 3 T  
 4

*rall poco a poco*

254

violin (vln), clarinet (cl), violin (Ve), and piano (pno) staves. The piano part includes the instruction *loco* and *f [Bell-like]*. The clarinet part includes *f [BELL-LIKE]*. The violin part includes *f [BELL-LIKE]*. The piano part includes a triplet of eighth notes and a 6-measure rest.

258 ♩ = 69

vln

cl

vc

pno

\* Allow the resonance of the piano to die away before starting each new phrase in this section.

263

vln

cl

vc

pno

ped. sempre

268

vln

pp

cl

pp

vc

[pizz]<sup>o</sup>

L.V.

pno

pp

vln

cl

pno

# *Double Escapement*

---

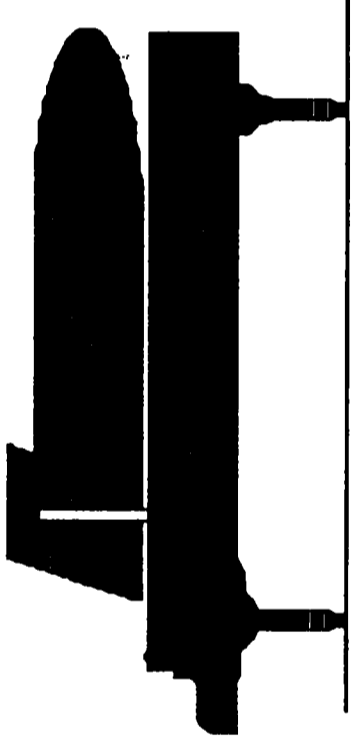

*Michael Alcorn*

*1992*

---





## Performance Notes

- The opening section should be played with a degree of rubato: for example, the semi-quavers can be played as grace notes figurations at times. The timings of this section are relatively free, although the plucked notes should be played before the pitch 'E' is introduced on tape.

At all times the performer should remain poised at the keyboard ready to play.

- Harmonics: The position at which these strings should be stopped varies from instrument to instrument. These are usually found within a meter beyond the hammers. It is advised that these positions are marked with chalk for each string.

- NOTE: The tempo change at 4'40" :

$$\text{♩} = 60 \text{ to } \text{♩} = 60$$

The barlines throughout the work denote approximate time intervals of 4 seconds.

- The complexity and speed of the music from 4'40" onwards may provide problems in performance. If this is the case the player should "jump ahead" to any of the points cued on the tape.
- Accidentals apply throughout the bar.
- The suggested pedal markings indicate key resonances in the piece. Depending on the timbre of the piano additional pedalling may be added.

## RECOMMENDED EQUIPMENT SETUP

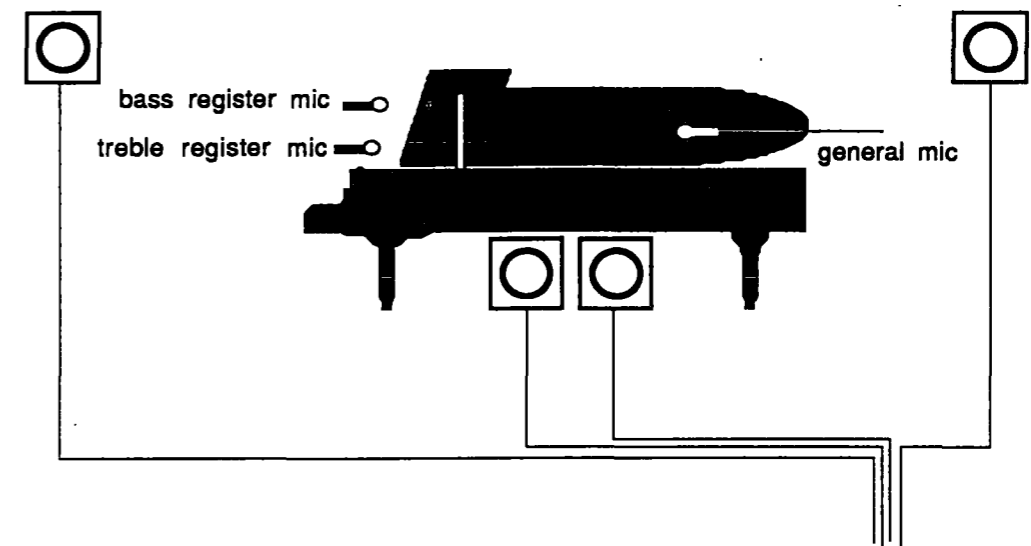

- Microphones should be placed to ensure that the plucked strings and harmonics are clearly audible and that a 'bright' timbre is achieved to match the tape sounds in the remainder of the piece.
- Reverb (SPX90II: Hall preset) and delay (Lexicon PCM70: 4 voice delay preset) should be added to colour the live piano timbre.
- At least two pairs of loudspeakers should be used in performance. A narrow image, placed underneath the piano, should be used during the opening passage. Over the four minute period of this section the image should be panned out to the widest pair for the second section.
- The tape levels should be exaggerated during performance: the opening passage can be 'tweaked' to keep the levels down. The lead-in to 4'40" should be increased to heighten the sudden change of dynamic. A similar manipulation should be used for the end of the piece.
- Depending on room acoustics and the timbre of the live piano, it may be necessary to EQ the tape (HF band -15dB).

# DOUBLE ESCAPEMENT

Michael Alcorn

The first system of the musical score consists of two staves. The upper staff is a treble clef staff with a wavy line above it, labeled "tape". The lower staff is a bass clef staff. A tempo marking "♩ = 60" is placed between the staves. Timecode markers are present: "00'00\"", "00'04\"", "00'08\"", and "00'12\"". A *ppp* dynamic marking is located above the upper staff.

The second system of the musical score consists of two staves. The upper staff is a treble clef staff with a wavy line above it, labeled "tape". The lower staff is a bass clef staff. A tempo marking "♩ = 60" is placed between the staves. Timecode markers are present: "00'16\"", "00'20\"", "00'24\"", and "00'28\"". A *ppp* dynamic marking is located above the upper staff. A slur with the word "(Lontano)" is placed over the upper staff. A *ppp* dynamic marking is located above the lower staff. A fermata is placed over a note in the lower staff. A legend at the bottom right shows a bracket labeled "sempre" and a line labeled "u.c. sempre".

tape

00'48" 00'52" 00'56" 01'00"

*pppp*

*ppp*

6

7

3

3

tape

00'36" 00'40" 00'44" 00'44" 01'00"

*pppp*

*ppp*

3

3

01'04" ppp

01'08" ppp

01'12" ppp

01'16" ppp

cres poco a poco

pp

6

7

8

tape

01'20" pppp

01'24" pppp

01'28" pp

01'32" mp

cres poco a poco

pp

mp

7

8

9

tape

tape

*cres poco a poco*

*pp*

*ff*

01'36"

01'40"

01'44"

01'48"

*pp*

8<sup>va</sup>-----1

6

tape

01'52"

01'56"

*ppp*

*p*

02'00"

02'04"

*dim poco a poco*

7

8<sup>va</sup>-----1

6

tape

dim poco a poco

02'08" 8<sup>va</sup> pp

02'12" 8<sup>va</sup> mp

02'16" mp

02'20" 8<sup>va</sup> pp

6

tape

dim poco a poco

02'24" 8<sup>va</sup> pp

02'28" 8<sup>va</sup> ppp

02'32" 8<sup>va</sup> ppp

02'36" 8<sup>va</sup> ppp

5

5

tape

dim poco a poco - - - - -

02:40

02:44

02:45

02:52

*pppp*

tape

02:56

03:00

03:04

03:08

Plucked \*

*pp*

senza u.c.

• the string should be plucked with the fleshy part of the finger

tape

(low phasing texture)

03'12" *ppp* 03'16" 03'24" sounding pitch\*\*

Plucked \*

*pp* l.v.

\* the string should be plucked with the fleshy part of the finger

tape

03'28" 03'32" sounding pitch\*\* 03'36" 03'40" sounding pitch\*\*

*p* *p*

\*\* HARMONICS -  
the strings should be stopped at the position  
which will produce the notated harmonic  
as clearly as possible



tape

03:44" *sim.* *p*

03:48" *p*

03:52" *p*

03:56" *p* Plucked \*

tape

04:00" *p*

04:04" *p*

04:08" *p*

04:12" *p*

tape

04'16" 04'20" 04'24" 04'28"

fingering

*mf*

tape

04'32" 04'36" 04'40"

*ppp* *ff* *Explosive...* *sfz* *fff*

$\text{♩} = 120$

tape

04'44"

Musical score for the first system. The piano part consists of six staves with six-measure phrases and triplet markings. The vocal line includes dynamic markings such as *sfz* and *ff*. The system is labeled with a timecode of 04'44".

04'48"

tape

04'52"

04'56"

Musical score for the second system. It continues the piano and vocal parts from the first system, featuring similar six-measure phrases and dynamic markings like *sfz*. The system is labeled with timecodes 04'52" and 04'56".

*ff*

tape

*pp*

*mp*

*sfz*

*cres poco a poco*

tape

*f*

*dim poco a poco*

tape

05'16"

trill

*sfz p*

*f*

*pp*

*ff*

05'20"

tape

12

tape

05'24"

pizz

*sfz*

*ff*

05'28"

pizz

*ff*

*sfz*

tape

12

tape

05'32"

*tremolo*

*sfz*

05'36"

This system contains two staves. The upper staff is a piano part with a section of tremolo. The lower staff is a vocal line with various intervals and dynamics. Time markers 05'32" and 05'36" are present.

tape

05'40"

*sfz*

*ff*

05'44"

This system contains two staves. The upper staff is a piano part with a section of tremolo. The lower staff is a vocal line with various intervals and dynamics. Time markers 05'40" and 05'44" are present.

tape

Musical score for the top system, featuring piano and violin parts. The piano part is written in treble clef and includes various annotations such as *tr*, *sfz*, and *tr* with wavy lines. The violin part is written in treble clef and includes time markers like 05:48" and 05:52". There are also *tr* and *sfz* markings in the violin part. The score is divided into measures by vertical bar lines, with some measures containing rests.

tape

Musical score for the bottom system, featuring piano and violin parts. The piano part is written in treble clef and includes various annotations such as *tr*, *sfz*, and *tr* with wavy lines. The violin part is written in treble clef and includes time markers like 05:56" and 06:00". There are also *tr* and *sfz* markings in the violin part. The score is divided into measures by vertical bar lines, with some measures containing rests.

tape

08'04''

[PEDAL]

08'08''

08'12''

08'16''

piano



tape

06'20"

06'24"

*sfz*

*sfz*

*tr*

tape

06'28"

06'36"

*tr*

*tr*

*tr*



tape

06:52''

tutta forza

pppp

ppp

08:38''

07:00''

leggero

pppp

uc

1/2 ped. sempre

07:04''

ffff

Slow RELEASE

tape

07:00''

leggero

pppp

uc

1/2 ped. sempre

07:04''

07'08"

tape

07'08"

07'12"

*pppp*

07'16"

tape

07'16"

07'20"

07'20"

tape

0724"

0728"

tape

0732"

0736"

tape

07:40

07:44

tape

07:52

low 3 flat pedal

07:48

tape

07'56" *pizz*

*f*

*cres poco a poco*

08'00"

This system contains two staves. The upper staff is for piano, starting with a dynamic marking of *f* and a *cres poco a poco* instruction. The lower staff is for bassoon, marked *pizz*. Time markers 07'56" and 08'00" are present. Rehearsal marks with numbers 6 and 3 are used throughout.

tape

08'04" *pizz*

08'08" *pizz*

This system continues the musical score with two staves. The upper staff is for piano and the lower for bassoon, both marked *pizz*. Time markers 08'04" and 08'08" are present. Rehearsal marks with numbers 6 and 3 are used throughout.

tape

tape



tape

08'28"

08'32"

*fff*

tr

tape

08'36"

08'40"

tr

08'44"

08'48"

tape

08'56"

tape

08'52"

chromatic clusters

tutta forza

fff

09'00" *lape*

09'04" *sfz*

*fff*

*tutta forza*

*tutta forza*

*tutta forza*

09'20"

09'20"

The image shows a musical score for guitar and piano. The top system consists of six staves, with the first two containing guitar notation and the remaining four containing piano notation. The score includes time stamps in boxes: "09'00\"", "09'04\"", and "09'20\"". Performance markings include "lape" (laptop), "fff" (fortissimo), and "tutta forza" (tutti). The piano part features a series of chords with dynamic markings. The guitar part includes various techniques such as lapping and slurs. The score is oriented vertically on the page.

# *Double Escapement*

---

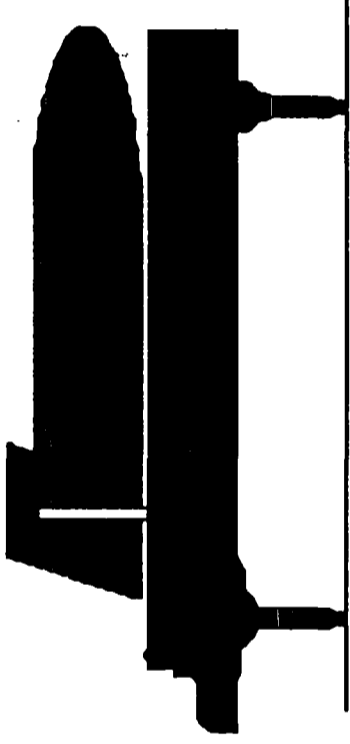

*Michael Alcorn*

*1992*

---



## Performance Notes

- The opening section should be played with a degree of rubato: for example, the semi-quavers can be played as grace notes figurations at times. The timings of this section are relatively free, although the plucked notes should be played before the pitch 'E' is introduced on tape.

At all times the performer should remain poised at the keyboard ready to play.

- Harmonics: The position at which these strings should be stopped varies from instrument to instrument. These are usually found within a meter beyond the hammers. It is advised that these positions are marked with chalk for each string.

- NOTE: The tempo change at 4'40" :

$$\text{♩} = 60 \text{ to } \text{♩} = 60$$

The barlines throughout the work denote approximate time intervals of 4 seconds.

- The complexity and speed of the music from 4'40" onwards may provide problems in performance. If this is the case the player should "jump ahead" to any of the points cued on the tape.
- Accidentals apply throughout the bar.
- The suggested pedal markings indicate key resonances in the piece. Depending on the timbre of the piano additional pedalling may be added.

## RECOMMENDED EQUIPMENT SETUP

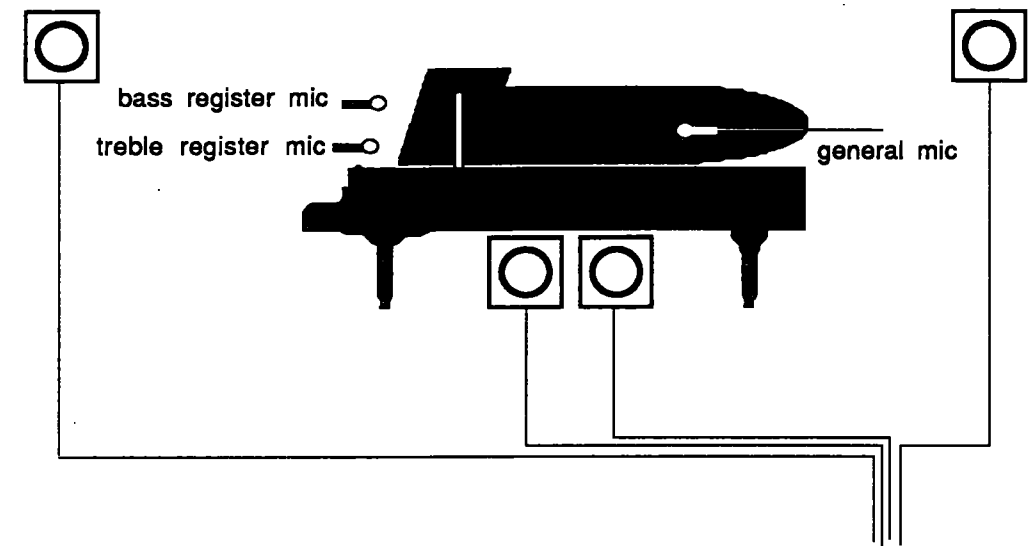

- Microphones should be placed to ensure that the plucked strings and harmonics are clearly audible and that a 'bright' timbre is achieved to match the tape sounds in the remainder of the piece.
- Reverb (SPX90II: Hall preset) and delay (Lexicon PCM70: 4 voice delay preset) should be added to colour the live piano timbre.
- At least two pairs of loudspeakers should be used in performance. A narrow image, placed underneath the piano, should be used during the opening passage. Over the four minute period of this section the image should be panned out to the widest pair for the second section.
- The tape levels should be exaggerated during performance: the opening passage can be 'tweaked' to keep the levels down. The lead-in to 4'40" should be increased to heighten the sudden change of dynamic. A similar manipulation should be used for the end of the piece.
- Depending on room acoustics and the timbre of the live piano, it may be necessary to EQ the tape (HF band -15dB).

# DOUBLE ESCAPEMENT

Michael Alcorn

musical score for the first system of "DOUBLE ESCAPEMENT". It features a grand staff with three staves. The top staff is a treble clef with a piano (*ppp*) dynamic marking. The middle and bottom staves are bass clefs. A "tape" label is positioned below the top staff. Timecode markers are placed in boxes: 00'00" (with a quarter note symbol and =60), 00'04", 00'08", and 00'12".

musical score for the second system of "DOUBLE ESCAPEMENT". It features a grand staff with three staves. The top staff is a treble clef with a piano (*ppp*) dynamic marking. The middle and bottom staves are bass clefs. A "tape" label is positioned below the top staff. Timecode markers are placed in boxes: 00'16", 00'20", 00'24", and 00'28". The word "(Lontano)" is written below the top staff. A *ppp* dynamic marking is also present. A legend at the bottom right shows a line with a hook for "sempre" and a line with a dot for "u.c. sempre".

The image shows two systems of musical notation, each consisting of a 'tape' track and a piano track. The piano tracks contain musical notation with various dynamic markings and timecode markers.

**System 1 (Top):**

- Tape Track:** Shows a series of vertical lines representing a tape recording.
- Piano Track:** Contains musical notation with dynamic markings *pppp* and *ddd*. It includes timecode markers in boxes: 00'48", 00'52", 00'56", and 01'00". There are also markings for *ppp* and a triplet of notes.

**System 2 (Bottom):**

- Tape Track:** Shows a series of vertical lines representing a tape recording.
- Piano Track:** Contains musical notation with dynamic markings *ddd* and *ppp*. It includes timecode markers in boxes: 00'36", 00'40", 00'44", and 00'44". There are also markings for a triplet of notes and a *ppp* dynamic marking.

Musical score for the first system. The score is written on two staves. The top staff is labeled "tape" and contains a series of notes with a dynamic marking of *pp*. The bottom staff contains piano notation with dynamic markings of *ppp* and *pp*. Time stamps in boxes are placed at 01'04", 01'08", 01'12", and 01'16". A "cres poco a poco" instruction is written above the tape staff. Fingerings 6, 7, 5, and 6 are indicated for the piano part.

Musical score for the second system. The score is written on two staves. The top staff is labeled "tape" and contains notes with a dynamic marking of *mp*. The bottom staff contains piano notation with dynamic markings of *ppp*, *pp*, and *p*. Time stamps in boxes are placed at 01'20", 01'24", 01'28", and 01'32". A "cres poco a poco" instruction is written above the tape staff. Fingerings 7, 5, and 9 are indicated for the piano part.



Musical score for the top system. It consists of a piano part (treble clef) and a guitar part (treble clef). The piano part includes a triplet of eighth notes marked *ddd* at 01:52, a dynamic of *p* at 01:56, and a sixteenth-note sextuplet at 02:00. The guitar part features a *8va* marking at 01:52 and a *7* marking at 02:04. The score concludes with a *dim poco a poco* instruction and a *7* marking at the bottom.

Musical score for the bottom system. It consists of a piano part (treble clef) and a guitar part (treble clef). The piano part starts with a dynamic of *pp* at 01:36, followed by a *mf* marking at 01:40, a *p* marking at 01:44, and a *pp* marking at 01:48. It includes a sixteenth-note sextuplet at 01:48 and a *7* marking at the end. The guitar part features a *cres poco a poco* instruction at 01:36, a *mf* marking at 01:40, and a *8va* marking at 01:48. The score concludes with a *7* marking at the bottom.

tape

dim poco a poco

02'08"

02'12"

02'16"

02'20"

8<sup>va</sup>

*pp*

*mp*

*pp*

*pp*

6

Detailed description: This system of musical notation consists of two staves. The upper staff contains a melodic line with various dynamics including *pp* and *mp*. The lower staff provides harmonic support. Time markers in boxes indicate specific points in the recording: 02'08", 02'12", 02'16", and 02'20". An 8<sup>va</sup> marking is present above the upper staff. A bracket with the number 6 spans a section of the lower staff.

tape

dim poco a poco

02'24"

02'28"

02'32"

02'36"

8<sup>va</sup>

*pp*

*pppp*

*pppp*

5

5

Detailed description: This system of musical notation consists of two staves. The upper staff contains a melodic line with dynamics including *pp* and *pppp*. The lower staff provides harmonic support. Time markers in boxes indicate specific points in the recording: 02'24", 02'28", 02'32", and 02'36". An 8<sup>va</sup> marking is present above the upper staff. Two brackets with the number 5 are located below the lower staff.

tape

02:40" 02:44" 02:48" 02:52"

*pppp*

dim poco a poco

tape

tape

02:56" 03:00" 03:04" 03:08"

Plucked

*pp*

senza u.c.

the string should be plucked with the fleshy part of the finger

tape

tape

(low phasing texture)

03'12" *ppp* 03'16" 03'24" sounding pitch\*\*

Plucked \*

*pp* l.v.

\* the string should be plucked with the fleshy part of the finger

tape

03'28" 03'32" sounding pitch\*\* 03'36" 03'40" sounding pitch\*\*

*p* *p*

\*\* HARMONICS - the strings should be stopped at the position which will produce the notated harmonic as clearly as possible

tape

03'44" 03'48" 03'52" 03'56"

sim.

*p*

*p*

*p*

*p*

Plucked \*

tape

04'00" 04'04" 04'08" 04'12"

*p*

*p*

*p*

*p*

tape

04'16" 04'20" 04'24" 04'28"

fingergliss

*mf*

tape

04'32" 04'36" 04'40"

*ppp* *ff*

$\text{♩} = 120$

Explosive...

*fff* *sfz* *sfz*

tape

04'44"

Musical score for the first system, measures 1-10. The piano part consists of six staves. The vocal line is on a single staff. Dynamics include *sfz*, *ff*, and *V*. There are various musical notations such as slurs, accents, and triplets. A section labeled 'NON' is indicated.

04'48"

tape

04'52"

Musical score for the second system, measures 11-20. The piano part consists of six staves. The vocal line is on a single staff. Dynamics include *sfz* and *V*. There are various musical notations such as slurs, accents, and triplets.

04'56"

05'00"

*ff*

tape

*pp*

*mp*

*sfz*

cres poco a poco

05'08"

tape

*f*

*dim poco a poco*



tape

05'16"

*tr* *sfz p* *f* *pp* *ff* *sfz*

05'20"

tape

tape

05'24"

*tr* *sfz p* *f* *pp* *ff* *sfz*

05'28"

tape

tape

Musical score for the first system. The piano part is written on a grand staff with a 'tape' label. The vocal line is on a single staff with a box containing '05:32'. The score includes various musical notations such as notes, rests, and dynamic markings.

05:36

Musical score for the second system. The piano part is written on a grand staff with a 'tape' label. The vocal line is on a single staff with a box containing '05:32'. The score includes various musical notations such as notes, rests, and dynamic markings.

tape

Musical score for the third system. The piano part is written on a grand staff with a 'tape' label. The vocal line is on a single staff with a box containing '05:40'. The score includes various musical notations such as notes, rests, and dynamic markings.

05:44

Musical score for the fourth system. The piano part is written on a grand staff with a 'tape' label. The vocal line is on a single staff with a box containing '05:40'. The score includes various musical notations such as notes, rests, and dynamic markings.



tape

06'04"

[PEDAL]

06'08"

tr (b2)

tr

tr

tr

06'12"

06'16"

The image shows a musical score for a tape recording, consisting of multiple staves. The notation is dense and complex, featuring various rhythmic patterns and melodic lines. The score is divided into measures by vertical bar lines. There are several key markings and annotations:
 

- 06'04" and 06'08":** Time markers in boxes.
- [PEDAL]:** A bracketed instruction indicating a pedal point.
- tr (b2):** Trill markings with a second flat.
- tr:** Trill markings without a second flat.
- 06'12" and 06'16":** Additional time markers in boxes.
- Staff 1:** Contains a complex melodic line with many sixteenth and thirty-second notes, often beamed together in groups of 5 or 6.
- Staff 2:** Features a steady, rhythmic accompaniment, possibly a bass line or a constant eighth-note pattern.
- Staff 3:** Shows a melodic line with some rests and dynamic markings like *tr*.
- Staff 4:** Contains a melodic line with various accidentals and articulation marks.
- Staff 5:** Shows a melodic line with some rests and dynamic markings like *tr*.
- Staff 6:** Contains a melodic line with some rests and dynamic markings like *tr*.
- Staff 7:** Shows a melodic line with some rests and dynamic markings like *tr*.
- Staff 8:** Contains a melodic line with some rests and dynamic markings like *tr*.
- Staff 9:** Shows a melodic line with some rests and dynamic markings like *tr*.
- Staff 10:** Contains a melodic line with some rests and dynamic markings like *tr*.
- Staff 11:** Shows a melodic line with some rests and dynamic markings like *tr*.
- Staff 12:** Contains a melodic line with some rests and dynamic markings like *tr*.
- Staff 13:** Shows a melodic line with some rests and dynamic markings like *tr*.
- Staff 14:** Contains a melodic line with some rests and dynamic markings like *tr*.
- Staff 15:** Shows a melodic line with some rests and dynamic markings like *tr*.
- Staff 16:** Contains a melodic line with some rests and dynamic markings like *tr*.
- Staff 17:** Shows a melodic line with some rests and dynamic markings like *tr*.
- Staff 18:** Contains a melodic line with some rests and dynamic markings like *tr*.
- Staff 19:** Shows a melodic line with some rests and dynamic markings like *tr*.
- Staff 20:** Contains a melodic line with some rests and dynamic markings like *tr*.

tape

Musical score for the top system. The piano part (left) features complex chords with intervals of 6, 3, and 5. It includes dynamic markings such as *sfz* and *tr*. The guitar part (right) features a tremolo effect, indicated by a wavy line, and includes a *pick* instruction. Timecode markers are present at 06:20", 06:24", and 06:36".

tape

Musical score for the bottom system. The piano part (left) features complex chords with intervals of 6, 3, and 5. It includes dynamic markings such as *sfz* and *tr*. The guitar part (right) features a tremolo effect, indicated by a wavy line, and includes a *pick* instruction. Timecode markers are present at 06:28" and 06:36".



tape

tutti forza

tr

ppp

06:52

*ffff*

SLOW RELEASE

tape

tr

ppp

07:00

leggiero

07:04

ppp

1/2 ped. sempre

07:04

07'08"

tape

07'08"

pppp

6

07'12"

07'16"

tape

07'16"

3

6

07'20"



tape

0724"

0728"

tape

0732"

0736"

07:40

07:40

07:52

07:52

tape

0755"  
piano

0800"  
cres poco a poco

This system contains two staves. The upper staff is a piano part with a key signature of one flat and a 6/8 time signature. It features a melodic line with dynamic markings including *f* and *cres poco a poco*. The lower staff is a tape part consisting of rhythmic patterns, with a box labeled "0755" and a "piano" marking. Brackets with the number "6" indicate measure groupings, and a bracket with "3" indicates a triplet. The system concludes with a final measure marked with a "6".

tape

0804"  
piano

0808"  
piano

This system also consists of two staves. The upper staff is a piano part, continuing the melodic line from the previous system. The lower staff is a tape part with a box labeled "0804" and a "piano" marking. Brackets with "6" and "3" are used for measure groupings and triplets throughout the system. The system ends with a final measure marked with a "6".

tape

tape

tape

08:28"

08:32"

08:32"

ff

08:36"

tape

08:36"

08:40"

08:40"

08:44"

tape

08'44"

08'48"

This system contains a tape recording of a complex, multi-layered texture on the left. The piano part on the right features a melodic line with trills (tr) and triplets (3). The notation includes various rhythmic values and dynamic markings.

tape

08'52"

08'56"

This system continues the tape recording and piano part. The piano part features a melodic line with trills (tr) and triplets (3). The notation includes various rhythmic values and dynamic markings.

tape

08'52"

08'56"

chromatic clusters

tutta forza

*fff*

This system continues the tape recording and piano part. The tape recording is labeled "chromatic clusters". The piano part features a melodic line with trills (tr) and triplets (3). The notation includes various rhythmic values and dynamic markings, including *tutta forza* and *fff*.

09'00"

lape

09'04"

*fff*

tutta forza

tutta forza

09'20"

**INCANTATION**

*for chamber orchestra*

Michael Alcorn  
1987





**Performance Instructions:**



Denotes highest note possible (strings only)



Senza Misura - without strict measurement:  
Players should try not to coordinate with  
each other during these passages



Denotes finger cues given by the conductor.  
When this is given players should move on  
to the next passage or section immediately.  
Exceptions to this are marked in the score.

Accidentals apply throughout the bar.

**♩ = 112**

Fl<sub>1</sub>

Fl<sub>2</sub>

Ob<sub>1</sub>

Ob<sub>2</sub>

Cl<sub>1</sub>

Cl<sub>2</sub>

Bsn<sub>1</sub>

Bsn<sub>2</sub>

Hn<sub>1</sub>

Hn<sub>2</sub>

Hn<sub>3</sub>

Hn<sub>4</sub>

Tpt

Trb<sub>1</sub>

Tba

**♩ = 112**

①      ②      ③      ④

Pn

Per

PERCussion

BASS DRUM

VI<sub>1</sub>

VI<sub>2</sub>

Vla

Vc

Cb

Fl<sub>1</sub>  
Fl<sub>2</sub>  
Ob<sub>1</sub>  
Ob<sub>2</sub>  
Cl<sub>1</sub>  
Cl<sub>2</sub>  
Bsn<sub>1</sub>  
Bsn<sub>2</sub>  
Hn<sub>1</sub>  
Hn<sub>2</sub>  
Hn<sub>3</sub>  
Hn<sub>4</sub>  
Tpt  
Trb<sub>1</sub>  
Tba

Detailed musical score for woodwind and brass instruments. The score is arranged in a system of 14 staves. The instruments listed are Flute 1 and 2, Oboe 1 and 2, Clarinet 1 and 2, Bassoon 1 and 2, Horn 1, 2, 3, and 4, Trumpet, Trombone 1, and Tuba. The notation includes various note values, rests, and dynamic markings such as *f*, *sfz*, *mp*, and *mf*. There are also some performance instructions like *tr* (trill) and *trmw* (trill with mordent).

Pn  
Per  
VI<sub>1</sub>  
VI<sub>2</sub>  
Vla  
Vc  
Cb

Detailed musical score for percussion and string instruments. The score is arranged in a system of 7 staves. The instruments listed are Piano (Pn), Percussion (Per), Violin 1 (VI<sub>1</sub>), Violin 2 (VI<sub>2</sub>), Viola (Vla), Violoncello (Vc), and Contrabass (Cb). The percussion part includes specific instructions for *VIB* (vibraphone), *Xylo* (xylophone), and *BONGOS*. The string parts include dynamic markings like *f*, *mp*, *sfz*, and *p*, as well as performance instructions such as *Pizz* (pizzicato) and *Div* (divisi). There are also circled numbers 1, 2, 3, and 4 below the percussion staff, likely indicating different rhythmic patterns or cues.

A

Fl<sub>1</sub>  
Fl<sub>2</sub>  
Ob<sub>1</sub>  
Ob<sub>2</sub>  
Cl<sub>1</sub>  
Cl<sub>2</sub>  
Bsn<sub>1</sub>  
Bsn<sub>2</sub>  
Hn<sub>1</sub>  
Hn<sub>2</sub>  
Hn<sub>3</sub>  
Hn<sub>4</sub>  
Tpt  
Trb<sub>1</sub>  
Tba

⑤    A    ⑩    ⑪    ⑫

Pn  
Per  
BONGOS

VI<sub>1</sub>  
VI<sub>2</sub>  
Vla  
Vc  
Cb

RALL — — — — — ♩ = 96

Fl<sub>1</sub>  
Fl<sub>2</sub>  
Ob<sub>1</sub>  
Ob<sub>2</sub>  
Cl<sub>1</sub>  
Cl<sub>2</sub>  
Bsn<sub>1</sub>  
Bsn<sub>2</sub>

Musical score for woodwinds and brass instruments. The staves are labeled Fl<sub>1</sub>, Fl<sub>2</sub>, Ob<sub>1</sub>, Ob<sub>2</sub>, Cl<sub>1</sub>, Cl<sub>2</sub>, Bsn<sub>1</sub>, and Bsn<sub>2</sub>. The music features various dynamics such as *f*, *sfz*, *mp*, and *ff*. There are trills and tremolos indicated in the woodwind parts.

Hr<sub>1</sub>  
Hr<sub>2</sub>  
Hr<sub>3</sub>  
Hr<sub>4</sub>  
Tpt  
Trb<sub>1</sub>  
Tba

Musical score for horns, trumpets, and trombones. The staves are labeled Hr<sub>1</sub>, Hr<sub>2</sub>, Hr<sub>3</sub>, Hr<sub>4</sub>, Tpt, Trb<sub>1</sub>, and Tba. The music includes dynamics like *f*, *sfz*, and *ff*. There are trills and tremolos in the horn parts.

⑬ RALL — — — — — ♩ = 96 ⑭ ⑮

Pn

Musical score for piano. The staff is labeled Pn. The music includes dynamics like *sfz* and *v.v.*. There are trills and tremolos in the right hand.

Per  
To Woodlocks

Musical score for percussion. The staff is labeled Per. It includes a section titled "To Woodlocks" with a 6-measure rest. Dynamics include *f* and *sfz*.

VI<sub>1</sub>  
VI<sub>2</sub>  
Vla  
Vc  
Cb

Musical score for strings. The staves are labeled VI<sub>1</sub>, VI<sub>2</sub>, Vla, Vc, and Cb. The music includes dynamics like *f*, *sfz*, and *p*. There are trills and tremolos in the violin parts.

Fl<sub>1</sub>  
Fl<sub>2</sub>  
Ob<sub>1</sub>  
Ob<sub>2</sub>  
Cl<sub>1</sub>  
Cl<sub>2</sub>  
Bsn<sub>1</sub>  
Bsn<sub>2</sub>  
Hn<sub>1</sub>  
Hn<sub>2</sub>  
Hn<sub>3</sub>  
Hn<sub>4</sub>  
Tpt  
Trb<sub>1</sub>  
Tba

Pn  
Per  
WOOD BLOCKS  
BASS DRUM

Vi<sub>1</sub>  
Vi<sub>2</sub>  
Vla  
Vc  
Cb

♩ = 112

To Picc

Fl<sub>1</sub>  
Fl<sub>2</sub>  
Ob<sub>1</sub>  
Ob<sub>2</sub>  
Cl<sub>1</sub>  
Cl<sub>2</sub>  
Bsn<sub>1</sub>  
Bsn<sub>2</sub>  
Hn<sub>1</sub>  
Hn<sub>2</sub>  
3  
4  
Tpt  
Trb<sub>1</sub>  
Tba

sfz p  
sfz  
mf  
mf  
f  
trun  
f  
trun  
f  
trun  
f  
sfz mf  
sfz mf  
f  
trun  
f  
trun  
f  
con cord. fis.  
f fis.

21 22 23 24

Pn  
Per  
Bassos  
VI<sub>1</sub>  
VI<sub>2</sub>  
Vla  
Vc  
Cb

sfz  
sfz  
To Vib  
xylo  
sfz  
sfz  
pizz  
arco  
mf  
ff  
sub p  
f  
pizz  
sfz  
sfz  
arco  
mf  
f  
mp  
fp  
trun  
f

21 22 23 24

B

Rec  
Fl<sub>1</sub>  
Fl<sub>2</sub>  
Ob<sub>1</sub>  
Ob<sub>2</sub>  
Cl<sub>1</sub>  
Cl<sub>2</sub>  
Bsn<sub>1</sub>  
Bsn<sub>2</sub>  
Hn<sub>1</sub>  
Hn<sub>2</sub>  
Hn<sub>3</sub>  
Hn<sub>4</sub>  
Tpt  
Tbn  
Tba

Musical score for woodwinds and brass instruments. The score includes parts for Flutes (Fl<sub>1</sub>, Fl<sub>2</sub>), Oboes (Ob<sub>1</sub>, Ob<sub>2</sub>), Clarinets (Cl<sub>1</sub>, Cl<sub>2</sub>), Bassoons (Bsn<sub>1</sub>, Bsn<sub>2</sub>), Horns (Hn<sub>1</sub>, Hn<sub>2</sub>, Hn<sub>3</sub>, Hn<sub>4</sub>), Trumpets (Tpt), and Trombones (Tbn, Tba). The notation includes various musical symbols such as notes, rests, and dynamic markings like *f*, *mf*, and *p*. A box labeled 'B' is present above the first staff.

25      26      B      27      28

Piano accompaniment staff showing measure numbers 25, 26, 27, and 28. A box labeled 'B' is positioned above the staff between measures 26 and 27.

Pn  
VIB  
Per  
Kyd  
Banos  
VI<sub>1</sub>  
VI<sub>2</sub>  
Via  
Vc  
Cb

Musical score for strings and percussion. The score includes parts for Piano (Pn), Vibraphone (VIB), Percussion (Per), Banjos (Banos), Violins (VI<sub>1</sub>, VI<sub>2</sub>), Viola (Via), Violoncello (Vc), and Contrabass (Cb). The notation includes various musical symbols such as notes, rests, and dynamic markings like *f*, *mf*, and *p*. A box labeled 'VIB' is present above the Vibraphone staff, and a box labeled 'Kyd' is present above the Percussion staff.



**Picc**  
Fl<sub>1</sub>  
Fl<sub>2</sub>  
Ob<sub>1</sub>  
Ob<sub>2</sub>  
Cl<sub>1</sub>  
Cl<sub>2</sub>  
Bsn<sub>1</sub>  
Bsn<sub>2</sub>

Woodwind section score including Piccolo, Flutes (Fl<sub>1</sub>, Fl<sub>2</sub>), Oboes (Ob<sub>1</sub>, Ob<sub>2</sub>), Clarinets (Cl<sub>1</sub>, Cl<sub>2</sub>), and Bassoons (Bsn<sub>1</sub>, Bsn<sub>2</sub>). The score features complex rhythmic patterns, dynamic markings such as *sfz*, *p sempre*, and *tr*, and articulation marks like *tr* and *tr* with wavy lines. A measure with a fermata and the number '5' is present in the Fl<sub>2</sub> part.

Hn<sub>1</sub>  
Hn<sub>2</sub>  
Hn<sub>3</sub>  
Hn<sub>4</sub>  
Tpt  
Trb<sub>1</sub>  
Tba

Brass section score including Horns (Hn<sub>1</sub>, Hn<sub>2</sub>, Hn<sub>3</sub>, Hn<sub>4</sub>), Trumpets (Tpt), Trombones (Trb<sub>1</sub>, Tba). The score includes dynamic markings like *sfz* and *mf*, and a box labeled "can cond" in the Trb<sub>1</sub> part.

Pn

Piano (Pn) score with complex rhythmic patterns and dynamic markings like *sfz*.

**VIB**  
Per  
**VULO**

Percussion (Per) and Vibraphone (VIB) score. The Vibraphone part includes a *marcato* marking.

VI<sub>1</sub>  
VI<sub>2</sub>  
Vla  
Vc  
Cb

String section score including Violins (VI<sub>1</sub>, VI<sub>2</sub>), Viola (Vla), Violoncello (Vc), and Contrabass (Cb). The score includes dynamic markings like *sfz* and *p33*, and the instruction *ARCO*.



♩ = 126

C

TO FLUTE

Fl<sub>1</sub>  
Fl<sub>2</sub>  
Ob<sub>1</sub>  
Ob<sub>2</sub>  
Cl<sub>1</sub>  
Cl<sub>2</sub>  
Bsn<sub>1</sub>  
Bsn<sub>2</sub>  
Hn<sub>1</sub>  
Hn<sub>2</sub>  
Hn<sub>3</sub>  
Hn<sub>4</sub>  
Tpt  
Trb<sub>1</sub>  
Trb<sub>2</sub>  
Tba

37 C 38 39 40

Pn  
Vib  
Per  
Xylo  
BONGOS  
VI<sub>1</sub>  
VI<sub>2</sub>  
Vla  
Vc  
Cb

TO WOODBLOCKS

Flute 1 (Flute) *sfz p*

Flute 2 *p sfz* *sfz p*

Oboe 1 *p sfz* *sfz p*

Oboe 2 *p sfz* *sfz p*

Clarinet 1 *p sfz* *sfz p*

Clarinet 2 *p sfz* *sfz p*

Bassoon 1 *p sfz* *sfz p*

Bassoon 2 *p sfz* *sfz p*

Horn 1 *p sfz* *f* *sfz ff*

Horn 2 *p sfz* *f* *sfz ff*

Horn 3 *p sfz* *f* *sfz ff*

Horn 4 *p sfz* *f* *sfz ff*

Trumpet *p sfz* *f* *sfz ff*

Trumpet 2 *p sfz* *f* *sfz ff*

Tuba *p sfz* *f* *sfz ff*

41 42 43 44

Piano (Pn) *p*

Drum (Per) *p* *#*

Violin 1 *f* *sfz ff*

Violin 2 *p sfz* *f* *sfz ff*

Viola *f* *sfz ff*

Violoncello (Vc) *f* *sfz ff*

Double Bass (Cb) *f* *sfz ff*

RAL - - - ♩ = 96

The musical score is arranged in systems. The first system includes woodwinds (Flutes 1 & 2, Oboes 1 & 2, Clarinets 1 & 2, Bassoons 1 & 2), Horns 1-4, Trumpets, Trombones, and Tuba. The second system includes Piano (Pn), Percussion (Per), and Bongos. The third system includes Violins 1 & 2, Viola, Violoncello (Vc), and Contrabass (Cb). The score features various musical notations such as dynamics (p, f, sfz), articulation (acc), and performance instructions like 'TO WOODBLOCKS', 'TO BASS DRUM', 'TO CLAPS', and 'SENZA MIBURA'. Measure numbers 45, 46, 47, and 48 are circled at the bottom of the woodwind section.

\* PLAYERS IN SENZA MIBURA GROUP SHOULD NOT CO-ORDINATE WITH EACH OTHER NOR WITH THE CONDUCTOR.

Fl<sub>1</sub>  
Fl<sub>2</sub>  
Ob<sub>1</sub>  
Ob<sub>2</sub>  
Cl<sub>1</sub>  
Cl<sub>2</sub>  
Bsn<sub>1</sub>  
Bsn<sub>2</sub>

Hn<sub>1</sub>  
Hn<sub>2</sub>  
Hn<sub>3</sub>  
Hn<sub>4</sub>  
Tpt  
Trb<sub>1</sub>  
Trb<sub>2</sub>  
Tba

Pn

Per  
Cms  
Toms

VI<sub>1</sub>  
VI<sub>2</sub>  
Vla  
Vc  
Cb



\* DOUBLE DOWN BEAT - Cue for strings to move to next section







RALL POCO A POCO

D2

TB Piece

Fl<sub>1</sub>  
Fl<sub>2</sub>  
Ob<sub>1</sub>  
Ob<sub>2</sub>  
Cl<sub>1</sub>  
Cl<sub>2</sub>  
Bsn<sub>1</sub>  
Bsn<sub>2</sub>

RALL POCO A POCO

Hn<sub>1</sub>  
3  
4  
Tpt  
Trb<sub>1</sub>  
Tba

RALL POCO A POCO

Pn

VI<sub>1</sub> [1-4]  
VI<sub>1</sub> [5-8]  
VI<sub>2</sub> [1-4]  
VI<sub>2</sub> [5-8]  
Vla  
Vc  
Cb

VERY SLOW GLISS

**♩ = 54**

**Picc**

**Fl<sub>1</sub>**

**Fl<sub>2</sub>**

**Ob<sub>1</sub>**

**Ob<sub>2</sub>**

**Cl<sub>1</sub>**

**Cl<sub>2</sub>**

**Bsn<sub>1</sub>**

**Bsn<sub>2</sub>**

**Hn<sub>1</sub>**

**Hn<sub>2</sub>**

**3**

**4**

**Tpt**

**Trb<sub>1</sub>**

**Tba**

*sempre vib* — — — *vib*

65 **♩ = 54** 66 67 68 69

**Pn**

**CLAVES**

**VI<sub>1</sub> [1-4]**

**VI<sub>1</sub> [5-8]**

**VI<sub>2</sub> [1-4]**

**VI<sub>2</sub> [5-8]**

**Vla**

**Vc**

**Cb**

*sempre*

*mp* *mp* *mf*

*no [1-4]*

*no [5-8]*

*mf*

*pp*

E

Fl<sub>1</sub>  
Fl<sub>2</sub>  
Ob<sub>1</sub>  
Ob<sub>2</sub>  
Cl<sub>1</sub>  
Cl<sub>2</sub>  
Bsn<sub>1</sub>  
Bsn<sub>2</sub>

Hn<sub>1</sub>  
Hn<sub>2</sub>  
Hn<sub>3</sub>  
Hn<sub>4</sub>  
Tpt  
Trb<sub>1</sub>  
Tba

Pn  
Per

VI<sub>1</sub>  
VI<sub>2</sub>  
Vla  
Vc  
Cb

Fl<sub>1</sub>  
Fl<sub>2</sub>  
Ob<sub>1</sub>  
Ob<sub>2</sub>  
Cl<sub>1</sub>  
Cl<sub>2</sub>  
Bsn<sub>1</sub>  
Bsn<sub>2</sub>

4/4 3/4

*p* *f* *p* *f*

Hn<sub>1</sub>  
Hn<sub>2</sub>  
Hn<sub>3</sub>  
Hn<sub>4</sub>  
Tpt  
Trb<sub>1</sub>  
Tba

4/4 3/4

Pn  
VIB  
Per

4/4

*pp* *p* *v.v.* *p*

75 76 77

*blocc* *SOLO V1*

VI<sub>1</sub>  
VI<sub>2</sub>  
Vla  
Vc  
Cb

4/4 3/4

*pp* *p* *mf*

ACCEL.

$\text{♩} = 84$  WALTZ!

PICC

Fl<sub>1</sub>  
Fl<sub>2</sub>  
Ob<sub>1</sub>  
Ob<sub>2</sub>  
Cl<sub>1</sub>  
Cl<sub>2</sub>  
Bsn<sub>1</sub>  
Bsn<sub>2</sub>  
Hn<sub>1</sub>  
Hn<sub>2</sub>  
Hn<sub>3</sub>  
Hn<sub>4</sub>  
Tpt  
Trb<sub>1</sub>  
Tba

⑬①      ⑬②       $\text{♩} = 84$  WALTZ!      ⑬③      ⑬④

Pn

Per

Violins

VI<sub>1</sub>  
VI<sub>2</sub>  
Vla  
Vc  
Cb

↓ ↓ **F** ①

**pizz**  
Fl<sub>1</sub>  
Fl<sub>2</sub>  
Ob<sub>1</sub>  
Ob<sub>2</sub>  
Cl<sub>1</sub>  
Cl<sub>2</sub>  
Bsn<sub>1</sub>  
Bsn<sub>2</sub>  
Hn<sub>1</sub>  
Hn<sub>2</sub>  
Tpt  
Trb<sub>1</sub>  
Tba

BREATHE QUICKLY WHEN NECESSARY

pp

*p* *sfz*

①② ①③ F ①④

Pn

**VIB**  
**Per**  
**Xylo**

Violini Solo

VI<sub>1</sub>  
VI<sub>2</sub>  
Vla  
Vc  
Cb

*p* *sfz* *Sempre pp*

MOLTO MARCATO

*pizz* # MOLTO MARCATO

*pizz* # MOLTO MARCATO

*pizz* # MOLTO MARCATO

*pizz* # MOLTO MARCATO

*pizz* # MOLTO MARCATO

*dim poco a poco*

*dim poco a poco*

*dim poco a poco*

*dim poco a poco*

*dim poco a poco*

(Cfr. GRADUALLY INCREASE DURATIONS OF RESTS)

F2

Musical score for page 22, featuring woodwinds, brass, strings, and percussion. The score is divided into several systems. The first system includes Flutes (Fl<sub>1</sub>, Fl<sub>2</sub>), Oboes (Ob<sub>1</sub>, Ob<sub>2</sub>), Clarinets (Cl<sub>1</sub>, Cl<sub>2</sub>), Bassoons (Bsn<sub>1</sub>, Bsn<sub>2</sub>), Horns (Hn<sub>1</sub>, Hn<sub>2</sub>, Hn<sub>3</sub>, Hn<sub>4</sub>), Trumpets (Tpt), Trombones (Trb<sub>1</sub>), and Tubas (Tba). The second system includes Percussion (Pn) and Xylophone (Xylo). The third system includes Violins (VI<sub>1</sub>, VI<sub>2</sub>), Viola (Vla), Violoncello (Vc), and Contrabass (Cb). A dynamic marking 'F2' is indicated at the top, with a downward arrow pointing to a vertical dashed line. The woodwind and brass parts show dynamic markings 'p' and 'sfz'.

G  
♩ = 60

Picc  
Oboe  
Clar.  
Bsn  
Hrn

♩ = 60

Piano  
Vib<sub>1</sub>  
Vib<sub>2</sub>  
Gongs

♩ = 60 G 85 86 87 88

SOLO VIOLIN

1  
2  
3  
4  
1  
2  
3  
4  
V<sub>1</sub>  
V<sub>2</sub>  
Vc  
Cb



piu mosso  $\text{♩} = 72$

Picc  
Oboe  
Clar.  
Bsn  
Hr

Piano  
Vib1  
Vib2  
Corns

piu mosso  $\text{♩} = 72$

Solo Violin  
Vl1  
Vl2  
Vla  
Vc  
Cb

rall - - - - ♩ = 60

Picc  
Oboe  
Clar.  
Bsn  
Hrn

PIANO  
VIB1  
VIB2  
GONGS

① ② ③ ④

SOLO VIOLIN  
V1  
V2  
Vla  
Vc  
Cb

# H

This musical score page, numbered 26, is divided into three systems. The first system includes Piccolo, Oboe, Clarinet, Bassoon, and Horn. The second system includes Piano, Violin I, Violin II, and Gongas. The third system includes Solo Violin, Violin I (4 staves), Violin II (4 staves), Viola, Violoncello, and Contrabass. The score is in common time (C) and features various dynamics such as *mf*, *p*, *pp*, and *pp sempre*. Performance instructions include *Bowed* and *To pp*. The Solo Violin part includes a *pp sempre* instruction. The Violin I and II parts have circled numbers 97, 98, 99, and 100. The Viola part includes a *B* marking. The Violoncello part includes a *B* marking. The Contrabass part includes a *B* marking.

Picc  
Oboe  
Clar.  
Bsn  
Hr

Piano  
Vib.  
Vib.  
Guitar

401 402 403 404

Solo Violin

1  
2  
3  
4  
1  
2  
3  
4  
Va  
Vc  
Cb

I

166

Picc

Oboe

Clar.

Bass

HW

*sffz ff*

*mp sempre*

*mp sempre*

166

Piano

Viola 1

Viola 2

Viola 3

Viola 4

*mf sempre v.v.*

*mf*

*f*

*mp*

166

165

166

167

168

Solo Violin

Violin 1

Violin 2

Violin 3

Violin 4

Violin 1

Violin 2

Violin 3

Violin 4

Viola

Violoncello

Contrabasso

*P33*

*GENZA Gued*

*ARCO*

*mp*

*mf*

*mp*

*ff*

*con cord*

*con cord*

*con cord*

*p*

Picc  
Oboe  
Clar.  
Bass  
Hr

PIANO

VIB<sub>1</sub>  
VIB<sub>2</sub>  
CONTR

SOLO VIOLIN

V<sub>1</sub>  
1  
2  
3  
4  
V<sub>2</sub>  
1  
2  
3  
4

V<sub>3</sub>  
Vc  
Cb

Picc

Oboe

Clar.

Bass

Hr

1<sup>o</sup>

2<sup>o</sup>

Piano

Vcl. I

Vcl. II

Contra

142

144

145

146

Tutti

CON SORD

Vcl. I

1

2

3

4

Vcl. II

1

2

3

4

Vcl. III

Vcl. IV

Cb

IN ARCO

Pizz.

Picc *tr* *f* *tr* *mf* *sfz*

Oboe *f* *tr* *mf* *sfz*

Clar. **3** **4** **4**

Bsn

Hr

Piano

VIB<sub>1</sub>

VIB<sub>2</sub> *tr* *sfz*

CONDS **TR WOODBLOCKS**

(119) (120) (121) (122)

Tutti VIOLINS

1

2

3

4

V<sub>1</sub>

1

2

3

4

V<sub>2</sub>

V<sub>3</sub>

Vc

Cb

*arco* *f* *mp* *sfz* *mp* *sfz* *mp* *sfz* *mp* *sfz* *mp* *sfz*

*arco* *f* *sfz*

**3** **4** **4**

Pizz



J

Fl<sub>1</sub>  
Fl<sub>2</sub>  
Ob<sub>1</sub>  
Ob<sub>2</sub>  
Cl<sub>1</sub>  
Cl<sub>2</sub>  
Bsn<sub>1</sub>  
Bsn<sub>2</sub>  
Hn<sub>1</sub>  
Hn<sub>2</sub>  
Hn<sub>3</sub>  
Hn<sub>4</sub>  
Tpt  
Trb<sub>1</sub>  
Tba

123 124 125 126

Pn

WOOD BLOCKS  
Per  
VIB

4

VI 1+2  
1-4  
TACET  
5-8  
VI 1  
mp sempre  
5-8  
VI 2  
mp sempre  
Vla  
pizz sfz sfz ARCO f  
Vc  
Cb

♩ = 76

♩ = 84

picc  
Fl<sub>1</sub>  
Fl<sub>2</sub>  
Ob<sub>1</sub>  
Ob<sub>2</sub>  
Cl<sub>1</sub>  
Cl<sub>2</sub>  
Bsn<sub>1</sub>  
Bsn<sub>2</sub>  
Hn<sub>1</sub>  
Hn<sub>2</sub>  
Hn<sub>3</sub>  
Hn<sub>4</sub>  
Tpt  
Trb<sub>1</sub>  
Tba

126 127 128 129

Pn  
WOOD BLOCKS  
Per  
VIB

VI<sub>1</sub>  
5-8  
VI<sub>2</sub>  
5-8  
Vla  
Vc  
Cb

Picc  
 Fl<sub>1</sub>  
 Fl<sub>2</sub>  
 Ob<sub>1</sub>  
 Ob<sub>2</sub>  
 Cl<sub>1</sub>  
 Cl<sub>2</sub>  
 Bsn<sub>1</sub>  
 Bsn<sub>2</sub>  
 Hn<sub>1</sub>  
 Hn<sub>2</sub>  
 Hn<sub>3</sub>  
 Hn<sub>4</sub>  
 Tpt  
 Trb<sub>1</sub>  
 Trb<sub>2</sub>  
 Tba

(129) (130) (131) (132)

Pn

Wood Blocks  
 Per  
 Vib

VI<sub>1</sub>  
 VI<sub>2</sub>  
 Vla  
 Vc  
 Cb

RALL

K

♩=60

Fl<sub>1</sub> *picc*

Fl<sub>2</sub>

Ob<sub>1</sub>

Ob<sub>2</sub>

Cl<sub>1</sub>

Cl<sub>2</sub>

Bsn<sub>1</sub>

Bsn<sub>2</sub>

Hn<sub>1</sub>

Hn<sub>2</sub>

Hn<sub>3</sub>

Hn<sub>4</sub>

Tpt

Trb

Trb

123 124 126 K 126

Pn

sfz after v.v.

WOOD BLOCKS

Per

Tb VIB

VIB

X410

VI<sub>1</sub>

VI<sub>2</sub>

Vla

Vc

Cb

mp sub. p sempre.

Fl<sub>1</sub>  
Fl<sub>2</sub>  
Ob<sub>1</sub>  
Ob<sub>2</sub>  
Cl<sub>1</sub>  
Cl<sub>2</sub>  
Bsn<sub>1</sub>  
Bsn<sub>2</sub>

This section of the score covers measures 127 through 132. It includes parts for Flute 1 and 2, Oboe 1 and 2, Clarinet 1 and 2, Bassoon 1, and Bassoon 2. The woodwinds feature intricate melodic lines with frequent triplets and slurs. Dynamic markings include *mp* (mezzo-piano) and *p* (piano).

Hn<sub>1</sub>  
Hn<sub>2</sub>  
3  
4  
Tpt  
Trb<sub>1</sub>  
Tba

This section covers measures 127 through 132 for the brass instruments: Horn 1 and 2, Trumpet 3 and 4, Trumpet, Trombone 1, and Trombone. The brass parts are primarily melodic, with some rhythmic patterns. Dynamic markings include *mp* (mezzo-piano) and *p* (piano).

127 128 129 130

Pn  
Per

This section covers measures 127 through 132 for the piano and percussion. The piano part features complex textures with many triplets and slurs. The percussion part includes a variety of rhythmic patterns. Dynamic markings include *p* (piano) and *pp* (pianissimo).

VI<sub>1</sub>  
VI<sub>2</sub>  
Vla  
Vc  
Cb

This section covers measures 127 through 132 for the string instruments: Violin 1 and 2, Viola, Violoncello, and Contrabass. The strings provide harmonic support and rhythmic accompaniment. Dynamic markings include *mp* (mezzo-piano), *p* (piano), and *pp* (pianissimo).



Picc  
Oboe  
Clar.  
Bass  
Hr

Piano  
Vib1  
Vib2  
Gtr

STOP STRING INSIDE PIANO

mf lv. (1) (2) p lv. lv.

145 146 147 148

SOLO VIOLIN  
Vn1  
Vn2  
Vla  
Vc  
Cb

[Solo Vn.]

mp, p, f, ff

P133 GLISS

Picc  
Oboe  
Clar.  
Bsn.  
Hr.

Piano  
Vib.  
Vib.  
Corno

SOLO VIOLIN  
V1  
V2  
V3  
V4  
V5  
V6  
Vc  
Cb

crescendo  
TUTTA FORZA (VIOLINS ONLY)  
molto  
VIB ONLY TUTTA FORZA



# M

Picc  
Oboe  
Clar.  
Bsn  
Hrn

Piano

Tam-Tam

Cymbal

Gongs

M (152) (154) (155) (156)

Solo Violin

V1/2/3

V1/5

V1/4/7

V1/6/9

V1/2

V1/3/4

V1/5/6

V1/7/8

V1/9

Vc

Cb

ALL STRINGS - CHANGE BOW WHERE NECESSARY - ALWAYS WITH SFZ ACCENT

Picc  
Oboe  
Clar.  
Bsn  
Hr

Piano

Gonges

To Vib

Bowed Vib

(Bowed Cymal)

mf

mp

p

mf

p

Solo Violin

V1

V2

V3

Vc

Cb

1/2/3

4/5

4/7

8/9

1/2

3/4

5/6

7/8

N 1 3<sup>a</sup> 2 SENZA MIRA

Picc

Oboe

Clar.

Bass

Trb. *Wah-wah* SENZA SORD

Piano

Vib. *accel. molto*

Clock

Gongs

3<sup>a</sup> 161 SENZA MIRA 162

SOLO VIOLIN

V1

V2

V3

Vc

Cb

**O**  $\text{♩} = 96$  **ACCEL** -----

Fl<sub>1</sub>

Fl<sub>2</sub> *sfzp sempre*

Ob<sub>1</sub>

Ob<sub>2</sub> *sfzp sempre*

Cl<sub>1</sub> *sfzp sempre*

Cl<sub>2</sub> *sfzp sempre*

Bsn<sub>1</sub>

Bsn<sub>2</sub> *sfzp sempre*

Hn<sub>1</sub>

Hn<sub>2</sub> *sfzp sempre*

Hn<sub>3</sub>

Hn<sub>4</sub>

Tpt *sfzp sempre*

Trb<sub>1</sub>

Tba

4/4 **3**/**4**

163 164 165 166

Pn

VIB

Per

Xylo

VI<sub>1</sub> *sfzp sempre*

VI<sub>2</sub> *sfzp sempre non div.*

Vla *sfzp sempre*

Vc

Cb *sfzp mf*

4/4 **3**/**4**

(Accel) — ♩ = 112

Fl<sub>1</sub>  
Fl<sub>2</sub>  
Ob<sub>1</sub>  
Ob<sub>2</sub>  
Cl<sub>1</sub>  
Cl<sub>2</sub>  
Bsn<sub>1</sub>  
Bsn<sub>2</sub>  
Hn<sub>1</sub>  
2  
3  
4  
Tpt  
Trb<sub>1</sub>  
Tba  
Pn  
VIB  
Per  
Vla  
Vc  
Cb

167 168 169 170

CLAVES

sul pont.

46

This page of a musical score contains the following instruments and parts:

- Woodwinds:** Piccolo Flute 1 (pic Fl<sub>1</sub>), Flute 2 (Fl<sub>2</sub>), Oboe 1 (Ob<sub>1</sub>), Oboe 2 (Ob<sub>2</sub>), Clarinet 1 (Cl<sub>1</sub>), Clarinet 2 (Cl<sub>2</sub>), Bassoon 1 (Bsn<sub>1</sub>), Bassoon 2 (Bsn<sub>2</sub>).
- Brass:** Horns 1 and 2 (Hn<sub>1</sub>, Hn<sub>2</sub>), Horns 3 and 4 (Hn<sub>3</sub>, Hn<sub>4</sub>), Trumpet (Tpt), Trombone 1 (Trb<sub>1</sub>), Trombone 2 (Trb<sub>2</sub>), Trombone 3 (Trb<sub>3</sub>).
- Strings:** Violin 1 (VI 1), Violin 2 (VI 2), Viola (Vla), Violoncello (Vc), Contrabass (Cb).
- Percussion:** Piano (Pn), Snare Drum (Per), Cymbals (CYMBALS).

The score includes various musical notations such as dynamics (p, mf, abp, subp), articulation (tr, accents), and performance instructions (ORD, TURN, PIZZ). The bottom right corner of the page features the number 47.

RALL - - - - -

Fl<sub>1</sub>  
Fl<sub>2</sub>  
Ob<sub>1</sub>  
Ob<sub>2</sub>  
Cl<sub>1</sub>  
Cl<sub>2</sub>  
Bsn<sub>1</sub>  
Bsn<sub>2</sub>  
Hn<sub>1</sub>  
Hn<sub>2</sub>  
Hn<sub>3</sub>  
Hn<sub>4</sub>  
Tpt  
Trb<sub>1</sub>  
Tba

Pn  
Per  
CLAVES

VI<sub>1</sub>  
VI<sub>2</sub>  
Vla  
Vc  
Cb

Q

$\text{♩} = 96$

ACCEL

picc Fl<sub>1</sub>  
 Fl<sub>2</sub>  
 Ob<sub>1</sub>  
 Ob<sub>2</sub>  
 Cl<sub>1</sub>  
 Cl<sub>2</sub>  
 Bsn<sub>1</sub>  
 Bsn<sub>2</sub>

Hn<sub>1</sub>  
 Hn<sub>2</sub>  
 Tpt  
 Trb<sub>1</sub>  
 Tba

178 190 202 214

Pn  
 VIB  
 Per  
 Vib

VI<sub>1</sub>  
 VI<sub>2</sub>  
 Vla  
 Vc  
 Cb



SENZA MISURA (fls Obs Cl)

ACCEL.

R

molto marcato

TO FLUTE

Musical score for woodwinds and brasses. Instruments include Flute 1 (Fl<sub>1</sub>), Flute 2 (Fl<sub>2</sub>), Oboe 1 (Ob<sub>1</sub>), Oboe 2 (Ob<sub>2</sub>), Clarinet 1 (Cl<sub>1</sub>), Clarinet 2 (Cl<sub>2</sub>), Bassoon 1 (Bsn<sub>1</sub>), Bassoon 2 (Bsn<sub>2</sub>), Horn 1 (Hn<sub>1</sub>), Horn 2 (Hn<sub>2</sub>), Horn 3 (Hn<sub>3</sub>), Horn 4 (Hn<sub>4</sub>), Trumpet (Tpt), Trombone 1 (Trb<sub>1</sub>), and Trombone 2 (Tba). The score features various dynamics such as *ff*, *sfz*, and *sfz ff*, and includes performance instructions like *tr*, *tr* (a), *tr* (b), *tr* (c), *tr* (d), *tr* (e), *tr* (f), *tr* (g), *tr* (h), *tr* (i), *tr* (j), *tr* (k), *tr* (l), *tr* (m), *tr* (n), *tr* (o), *tr* (p), *tr* (q), *tr* (r), *tr* (s), *tr* (t), *tr* (u), *tr* (v), *tr* (w), *tr* (x), *tr* (y), *tr* (z).

185

184

R

A TEMPO

185

186

Musical score for strings and percussion. Instruments include Piano (Pn), Vibraphone (VIB), Percussion (Per), Violin 1 (Vi<sub>1</sub>), Violin 2 (Vi<sub>2</sub>), Viola (Vla), Violoncello (Vc), and Contrabasso (Cb). The score includes dynamics such as *f*, *mf*, *fz*, *sfz*, *sfz ff*, and *gliss*. It also features performance instructions like *claps* and *gliss*.



Musical score for woodwinds and brass instruments. The score includes parts for Flute 1 (Fl<sub>1</sub>), Flute 2 (Fl<sub>2</sub>), Oboe 1 (Ob<sub>1</sub>), Oboe 2 (Ob<sub>2</sub>), Clarinet 1 (Cl<sub>1</sub>), Clarinet 2 (Cl<sub>2</sub>), Bassoon 1 (Bsn<sub>1</sub>), Bassoon 2 (Bsn<sub>2</sub>), Horns (Hn<sub>1-4</sub>), Trumpets (Trb), and Trombones (Tba). The score features various dynamics such as *mf*, *p*, *f*, and *sfz*. There are annotations including "STOP IMMEDIATELY" and "with U.s.". Rehearsal marks 3 and 4 are indicated with arrows pointing to specific measures.

197 198 199 200 201

Musical score for Piano (Pn), Vibraphone (VB), and Percussion (Per). The Piano part includes *sfz* markings. The Percussion part includes an *arco* marking. Rehearsal marks 200, 201, and 202 are shown in boxes.

Musical score for Violins (Vi<sub>1</sub>, Vi<sub>2</sub>), Viola (Vla), Violoncello (Vc), and Contrabass (Cb). The score includes various dynamics such as *sfz*, *p*, and *mf*. An *arco* marking is present in the Viola part.

Fl<sub>1</sub>  
Fl<sub>2</sub>  
Ob<sub>1</sub> *sotto voce*  
Ob<sub>2</sub> *sotto voce*  
Cl<sub>1</sub> *sotto voce*  
Cl<sub>2</sub>  
Bsn<sub>1</sub>  
Bsn<sub>2</sub>  
Hn<sub>1</sub>  
Hn<sub>2</sub> *p sotto voce*  
Hn<sub>3</sub>  
Hn<sub>4</sub>  
Tpt  
Trb<sub>1</sub>  
Tba

ACCEL POCO A POCO

457 498 498 480 504

Pn

ACCEL POCO A POCO

Vib  
Per  
XLO

Cuacx

Vi<sub>1</sub>  
Vi<sub>2</sub>  
Via  
Vc  
Cb

Fl<sub>1</sub>  
Fl<sub>2</sub>  
Ob<sub>1</sub>  
Ob<sub>2</sub>  
Cl<sub>1</sub>  
Cl<sub>2</sub>  
Bsn<sub>1</sub>  
Bsn<sub>2</sub>  
Hn<sub>1</sub>  
Hn<sub>2</sub>  
Hn<sub>3</sub>  
Hn<sub>4</sub>  
Tpt  
Trb<sub>1</sub>  
Tba

Detailed description: This section of the score covers woodwinds and brass. Flutes 1 and 2, Oboes 1 and 2, Clarinets 1 and 2, Bassoons 1 and 2, Horns 1-4, Trumpets, and Trombones are listed. The woodwinds have complex melodic lines with trills and slurs. The brass parts are more rhythmic and harmonic. There are dynamic markings like 'pp' and 'p'. The instruction 'STOP IMMEDIATELY' appears at the end of several woodwind staves.

ACCEL

203

204

205

206

Pn

Detailed description: The piano part consists of two staves. It is mostly blank, indicating that the piano is not playing during this section.

VIB  
Per  
Xulo  
VI<sub>1</sub>  
VI<sub>2</sub>  
Vla  
Vc  
Cb

Detailed description: This section covers strings and percussion. It includes Violins 1 and 2, Viola, Violoncello, Contrabass, Vibraphone, and Percussion (Xulo). The strings have complex rhythmic patterns with slurs and accents. The percussion part includes a 'BONGOS' section. There are dynamic markings like 'f' and 'pp'. The instruction 'ACCEL' is written at the bottom of the string section.

S  
SENZA MISURA

2

Fl<sub>1</sub>  
Fl<sub>2</sub>  
Ob<sub>1</sub>  
Ob<sub>2</sub>  
Cl<sub>1</sub>  
Cl<sub>2</sub>  
Bsn<sub>1</sub>  
Bsn<sub>2</sub>  
Hn<sub>1</sub>  
Hn<sub>2</sub>  
Hn<sub>3</sub>  
Hn<sub>4</sub>  
Tpt  
Trb<sub>1</sub>  
Tba

*ff TUTTA FORZA*  
*ff TUTTA FORZA*  
*ff TUTTA FORZA*  
*p*  
*con sord*  
*slow gliss*  
*mp quasi gliss*

SENZA MISURA

206

207

Pn  
Vib  
Per  
Xyb

VI<sub>1</sub>  
VI<sub>2</sub>  
Vla  
Vc  
Cb

*ff TUTTA FORZA*  
*ff TUTTA FORZA*  
*ff TUTTA FORZA*  
*slow gliss*  
*slow gliss*

PLAYERS SHOULD NOT TRY TO COORDINATE

3

Fl<sub>1</sub>

Fl<sub>2</sub>

Ob<sub>1</sub>

Ob<sub>2</sub>

Cl<sub>1</sub>

Cl<sub>2</sub>

Bsn

Bsn

Hn<sub>1</sub>

2

3

4

Tpt

Trb<sub>1</sub>

Trb<sub>2</sub>

Tba

Pn

Vb

Per

Vl<sub>1</sub>

Vl<sub>2</sub>

Vla

Vc

Cb

f TUTTA FORZA

SLOW GLISS TO E

SLOW GLISS TO E

QUART GLISS

snort

4  
 PLAY EITHER 1 OR 2 MORE REPEATS THEN GO ON IMMEDIATELY TO A BAR.

Fl<sub>1</sub>  
 Fl<sub>2</sub>  
 Ob<sub>1</sub>  
 Ob<sub>2</sub>  
 Cl<sub>1</sub>  
 Cl<sub>2</sub>  
 Bsn<sub>1</sub>  
 Bsn<sub>2</sub>  
 Hn<sub>1</sub>  
 Hn<sub>2</sub>  
 3  
 4  
 Tpt  
 Trb  
 Tba

*dim poco a poco*  
*dim poco a poco*  
*dim poco a poco*  
*dim poco a poco*  
*dim poco a poco*  
*dim poco a poco*  
*dim poco a poco*

SLOW GLISS

Pn  
 Per  
 VI<sub>1</sub>  
 VI<sub>2</sub>  
 Vla  
 Vc  
 Cb

*dim poco a poco*  
*dim poco a poco*  
*dim poco a poco*  
*dim poco a poco*  
*dim poco a poco*  
*dim poco a poco*

SLOW GLISS

PLAY EITHER 1 OR 2 MORE REPEATS THEN GO ON IMMEDIATELY TO A BAR.  
 57



T  $\text{♩} = 96$

RALL

Fl<sub>1</sub>  
Fl<sub>2</sub>  
Ob<sub>1</sub>  
Ob<sub>2</sub>  
Cl<sub>1</sub>  
Cl<sub>2</sub>  
Bsn<sub>1</sub>  
Bsn<sub>2</sub>  
Hn<sub>1</sub>  
Hn<sub>2</sub>  
Tpt  
Trb<sub>1</sub>  
Tba

BELL-LIKE

$\frac{3}{4}$

$\frac{3}{4}$

*p*, *pp*, *sfz*, *f*, *mf*, *p*

Pn  
Vib  
Per

$\text{♩} = 96$

RALL

200 205 210 211

*f*, *pp*, *sfz*

VI<sub>1</sub>  
VI<sub>2</sub>  
Via  
Vc  
Cb

$\frac{3}{4}$

*p*, *pp*

U 1 2

Fl<sub>1</sub>  
Fl<sub>2</sub>  
Ob<sub>1</sub>  
Ob<sub>2</sub>  
Cl<sub>1</sub>  
Cl<sub>2</sub>  
Bsn<sub>1</sub>  
Bsn<sub>2</sub>  
Hn<sub>1</sub>  
Hn<sub>2</sub>  
3  
4  
Tpt  
Trb<sub>1</sub>  
Tba

SENZA MISURA U 1 2

Pn  
Vib  
Per

VI<sub>1</sub>  
VI<sub>2</sub>  
Vln  
Vc  
Cb



INDEPENDENT RALLENTANDO IN ALL PARTS

6

7

Fl<sub>1</sub>

Fl<sub>2</sub>

Ob<sub>1</sub>

Ob<sub>2</sub>

Cl<sub>1</sub>

Cl<sub>2</sub>

Bsn<sub>1</sub>

Bsn<sub>2</sub>

Hn<sub>1</sub>

Hn<sub>2</sub>

Tpt

Trb<sub>1</sub>

Tba

INDEPENDENT RALLENTANDO IN ALL PARTS

Pn

Per

INDEPENDENT RALLENTANDO IN ALL PARTS

VI<sub>1</sub>

VI<sub>2</sub>

Vla

Vc

Cb

NON DU

NON DU

NON DU

Fl<sub>1</sub>  
Fl<sub>2</sub>  
Ob<sub>1</sub>  
Ob<sub>2</sub>  
Cl<sub>1</sub>  
Cl<sub>2</sub>  
Bsn<sub>1</sub>  
Bsn<sub>2</sub>  
Hn<sub>1</sub>  
Hn<sub>2</sub>  
Hn<sub>3</sub>  
Hn<sub>4</sub>  
Tpt  
Trb<sub>1</sub>  
Trb<sub>2</sub>  
Tba

Pn  
Per

VI<sub>1</sub>  
VI<sub>2</sub>  
Vla  
Vc  
Cb

88

88

V  
♩ = 120

Fl<sub>1</sub>  
Fl<sub>2</sub>  
Ob<sub>1</sub>  
Ob<sub>2</sub>  
Cl<sub>1</sub>  
Cl<sub>2</sub>  
Bsn<sub>1</sub>  
Bsn<sub>2</sub>  
Hn<sub>1</sub>  
Hn<sub>2</sub>  
Tpt  
Trb<sub>1</sub>  
Tba

213 214 215 216 217

Pn  
♩ = 120

Per  
xylo

Bass  
Drum

VI<sub>1</sub>  
VI<sub>2</sub>  
Vla  
Vc  
Cb

Fl<sub>1</sub>  
Fl<sub>2</sub>  
Ob<sub>1</sub>  
Ob<sub>2</sub>  
Cl<sub>1</sub>  
Cl<sub>2</sub>  
Bsn<sub>1</sub>  
Bsn<sub>2</sub>  
Hn<sub>1</sub>  
Hn<sub>2</sub>  
Tpt  
Trb  
Tba

Pn

Per  
Xylo

VI<sub>1</sub>  
VI<sub>2</sub>  
Vla  
Vc  
Cb

Fl<sub>1</sub>  
Fl<sub>2</sub>  
Ob<sub>1</sub>  
Ob<sub>2</sub>  
Cl<sub>1</sub>  
Cl<sub>2</sub>  
Bsn<sub>1</sub>  
Bsn<sub>2</sub>  
Hr<sub>1</sub>  
Hr<sub>2</sub>  
Tpt  
Trb  
Tba

Pn

Per

VI<sub>1</sub>  
VI<sub>2</sub>  
Vla  
Vc  
Cb





Fl<sub>1</sub>  
Fl<sub>2</sub>  
Ob<sub>1</sub>  
Ob<sub>2</sub>  
Cl<sub>1</sub>  
Cl<sub>2</sub>  
Bsn  
Bsn

4:6  
4:6  
sfz  
sfz  
sfz  
sfz  
sfz  
sfz  
sfz  
f  
f  
sfz

Hn<sub>1</sub>  
Hn<sub>2</sub>  
Tpt  
Trb  
Tba

sfz  
sfz  
sfz  
sfz  
p  
sfz  
f  
f  
f  
f > p

233 234 235 236 237

Pn

Per

VI<sub>1</sub>  
VI<sub>2</sub>  
Via  
Vc  
Cb

4:6  
4:6  
Div  
Div  
f > p  
f > p

X

Fl<sub>1</sub> *To Picc*

Fl<sub>2</sub>

Ob<sub>1</sub>

Ob<sub>2</sub>

Cl<sub>1</sub>

Cl<sub>2</sub>

Bsn<sub>1</sub>

Bsn<sub>2</sub>

Hn<sub>1</sub>

Hn<sub>2</sub>

Tpt

Trb<sup>1</sup>

Tba

238 239 240 241 242

Pn

vb

Per

xlo

VI<sub>1</sub>

VI<sub>2</sub>

Vla

Vc

Cb

*pp*

*cres. poco a poco*

*sempre p*

*mf*

*ff*

plcc  
Fl<sub>1</sub>  
Fl<sub>2</sub>  
Ob<sub>1</sub>  
Ob<sub>2</sub>  
Cl<sub>1</sub>  
Cl<sub>2</sub>  
Bsn<sub>1</sub>  
Bsn<sub>2</sub>  
Hn<sub>1</sub>  
Hn<sub>2</sub>  
Hn<sub>3</sub>  
Hn<sub>4</sub>  
Tpt  
Trb<sub>1</sub>  
Trb<sub>2</sub>  
Tba

243

244

245

246

247

Pn

vib  
Per  
xylo

VI<sub>1</sub>  
VI<sub>2</sub>  
Vla  
Vc  
Cb

plac Fl<sub>1</sub>  
Fl<sub>2</sub>  
Ob<sub>1</sub>  
Ob<sub>2</sub>  
Cl<sub>1</sub>  
Cl<sub>2</sub>  
Bsn<sub>1</sub>  
Bsn<sub>2</sub>  
Hr<sub>1</sub>  
Hr<sub>2</sub>  
Hr<sub>3</sub>  
Hr<sub>4</sub>  
Tpt  
Trb<sub>1</sub>  
Tba

248 249 250 251 252

Pn

Per  
Dr

VI<sub>1</sub>  
VI<sub>2</sub>  
Vla  
Vc  
Cb

# Y

Fl<sub>1</sub>  
Fl<sub>2</sub>  
Ob<sub>1</sub>  
Ob<sub>2</sub>  
Cl<sub>1</sub>  
Cl<sub>2</sub>  
Bsn<sub>1</sub>  
Bsn<sub>2</sub>  
Hn<sub>1</sub>  
Hn<sub>2</sub>  
Tpt<sub>1</sub>  
Tpt<sub>2</sub>  
Tbn<sub>1</sub>  
Tbn<sub>2</sub>

253 254 255 256 257

Pn  
Per

VI<sub>1</sub>  
VI<sub>2</sub>  
Vla  
Vc  
Cb

picc  
 Fl<sub>1</sub>  
 Fl<sub>2</sub>  
 Ob<sub>1</sub>  
 Ob<sub>2</sub>  
 Cl<sub>1</sub>  
 Cl<sub>2</sub>  
 Bsn<sub>1</sub>  
 Bsn<sub>2</sub>  
 Hn<sub>1</sub>  
 Hn<sub>2</sub>  
 3  
 4  
 Tpt  
 Trb<sub>1</sub>  
 Trb<sub>2</sub>  
 Tba

258  
 259  
 260  
 261  
 262

24

24

Pn  
 Per

VI<sub>1</sub>  
 VI<sub>2</sub>  
 Vla  
 Vc  
 Cb

24

ACCEL

MOLTO

TUTTU MOLTO MARCATO

Picc  
Fl<sub>1</sub>  
Fl<sub>2</sub>  
Ob<sub>1</sub>  
Ob<sub>2</sub>  
Cl<sub>1</sub>  
Cl<sub>2</sub>  
Bsn<sub>1</sub>  
Bsn<sub>2</sub>  
Hn<sub>1</sub>  
Hn<sub>2</sub>  
Hn<sub>3</sub>  
Hn<sub>4</sub>  
Tpt  
Trb<sub>1</sub>  
Trb<sub>2</sub>  
Tba

2  
4

ACCEL

MOLTO

TUTTU MOLTO MARCATO

Pn  
VIB  
Per  
xylo

76 164 265 266 267

VI<sub>1</sub>  
VI<sub>2</sub>  
Vla  
Vc  
Cb

133



2  
1

LUNGA

Picc  
Fl<sub>1</sub>  
Fl<sub>2</sub>  
Ob<sub>1</sub>  
Ob<sub>2</sub>  
Cl<sub>1</sub>  
Cl<sub>2</sub>  
Bsn<sub>1</sub>  
Bsn<sub>2</sub>  
Hn<sub>1</sub>  
Hn<sub>2</sub>  
Hn<sub>3</sub>  
Hn<sub>4</sub>  
Tpt  
Trb<sub>1</sub>  
Trb<sub>2</sub>  
Tba

268 269 270 271 272

Pn  
Vb  
Per  
Mjo

LUNGA  
CLAVES

VI<sub>1</sub>  
VI<sub>2</sub>  
Vla  
Vc  
Cb

DETUNE C → B<sup>b</sup>

(picc) Fl<sub>1</sub>  
 Fl<sub>2</sub>  
 Ob<sub>1</sub>  
 Ob<sub>2</sub>  
 Cl<sub>1</sub>  
 Cl<sub>2</sub>  
 Bsn<sub>1</sub>  
 Bsn<sub>2</sub>  
 Hn<sub>1</sub>  
 Hn<sub>2</sub>  
 Tpt  
 Trb<sub>1</sub>  
 Tba  
 Pn  
 vtr  
 Perc  
 xylo  
 Vl<sub>1</sub>  
 Vl<sub>2</sub>  
 Vla  
 Vc  
 Cb

273

274

275

276

(Pno Play only twice)

\* Vl<sub>1</sub>, Vl<sub>2</sub>, Vla  
 Cl<sub>1</sub>, Cl<sub>2</sub>  
 do not continue  
 until completing previous  
 ||: ||:~

picc Fl<sub>1</sub>  
Fl<sub>2</sub>  
Ob<sub>1</sub>  
Ob<sub>2</sub>  
Cl<sub>1</sub>  
Cl<sub>2</sub>  
Bsn<sub>1</sub>  
Bsn<sub>2</sub>  
Hn<sub>1</sub>  
Hn<sub>2</sub>  
3  
4  
Tpt  
Trb<sub>1</sub>  
Tba

Pn  
vib  
Per  
xylo

VI<sub>1</sub>  
VI<sub>2</sub>  
Vla  
Vc  
Cb

4 5

**SFORZANDO**

picc  
Fl<sub>1</sub>  
Fl<sub>2</sub>  
Ob<sub>1</sub>  
Ob<sub>2</sub>  
Cl<sub>1</sub>  
Cl<sub>2</sub>  
Bsn<sub>1</sub>  
Bsn<sub>2</sub>  
Hn<sub>1</sub>  
Hn<sub>2</sub>  
3  
4  
Tpt  
Trb<sub>1</sub>  
Tba  
Pn  
vib  
Per  
VI<sub>1</sub>  
VI<sub>2</sub>  
Vla  
Vc  
Cb

TRB1  
TRB2

281 282

**SFORZANDO**

**TO TIMP**

AA  $\text{♩} = 60$

picc  
Fl<sub>1</sub>  
Fl<sub>2</sub>  
Ob<sub>1</sub>  
Ob<sub>2</sub>  
Cl<sub>1</sub>  
Cl<sub>2</sub>  
Bsn  
Bsn

TUTTA FORZA

4  
4

Hn<sub>1</sub>  
Hn<sub>2</sub>  
Hn<sub>3</sub>  
Hn<sub>4</sub>  
Tpt  
Trb<sub>1</sub>  
Tba

TUTTA FORZA

4  
4

AA

Pn  
Vib  
Per

283 284 285

lv. lv. lv. lv.

TIMP\*

BASS DRUM

sfz sfz sfz sfz

Vi<sub>1</sub>  
Vi<sub>2</sub>  
Vla  
Vc  
Cb

4  
4

Bve Bve

\* TAMPANI — single large drum with skin slackened to resemble bassdrum timbre.

BB

1

picc Fl<sub>1</sub>  
Fl<sub>2</sub>  
Ob<sub>1</sub>  
Ob<sub>2</sub>  
Cl<sub>1</sub>  
Cl<sub>2</sub>  
Bsn<sub>1</sub>  
Bsn<sub>2</sub>  
Hn<sub>1</sub>  
Hn<sub>2</sub>  
Tpt  
Trb<sub>1</sub>  
Tba

Musical notation for woodwind and brass instruments. Dynamics include *sfz* and *GLISS*. A first ending bracket is present at the top right.

Pn  
VIB  
Per  
Timp  
BASS DRUM

Musical notation for percussion instruments. Dynamics include *sfz* and *lv.*. Measure numbers 286, 287, 288, and 289 are circled above the piano part.

VI<sub>1</sub>  
VI<sub>2</sub>  
Vla  
Vc  
Cb

Musical notation for string instruments. Dynamics include *mf* and *sfz*. Performance instructions include *LOCO*, *SENZA MIBARA*, and *TREM*.

# VLS 2-9

ca 50" to end

Fl<sub>1</sub>  
 Fl<sub>2</sub>  
 Ob<sub>1</sub>  
 Ob<sub>2</sub>  
 Cl<sub>1</sub> *pp* GLISS GLISS GLISS GLISS *x3* GLISS GLISS  
 Cl<sub>2</sub>  
 Bsn<sub>1</sub>  
 Bsn<sub>2</sub>  
 Hn<sub>1</sub>  
 Hn<sub>2</sub>  
 Hn<sub>3</sub>  
 Hn<sub>4</sub>  
 Tpt  
 Trb<sub>1</sub>  
 Trb<sub>2</sub>  
 Pn  
 Perc  
 Solo Violin *pp* GLISS SLOW TRON GLISS *x3* *x4*  
 VI<sub>1</sub> SLOW TRON GLISS  
 VI<sub>2</sub>  
 Vla  
 Vc  
 Cb

Fl<sub>1</sub>  
Fl<sub>2</sub>  
Ob<sub>1</sub>  
Ob<sub>2</sub>  
Cl<sub>1</sub>  
Cl<sub>2</sub>  
Bsn<sub>1</sub>  
Bsn<sub>2</sub>  
Hn<sub>1</sub>  
Hn<sub>2</sub>  
3  
4  
Tpt  
Trb<sub>1</sub>  
Trb<sub>2</sub>  
Pn  
Per  
Solo Violin  
VI<sub>1</sub>  
VI<sub>2</sub>  
Vla  
Vc  
Cb

GLISS GLISS

GLISS GLISS GLISS GLISS

(IRREGULAR DURATIONS) ppp

(REGULAR DURATIONS) ppp



# NB VIOLIN 1 + 2 LAST TO  
STOP PLAYING

# RECYCLE

for chamber ensemble

Michael Alcorn  
1986



**Instrumentation:**

flute (doubling alto & picc)

oboe (doubling Cor Anglais)

clarinet (B flat)

horn

trombone

violin

double bass

percussion:

xylophone

glockenspiel

vibraphone

tam-tam

2 gongs

3 tom-toms

bass drum

Score notated in C

# RECYCLE

Michael Alcorn.

$\text{♩} = 72$

fl. **2**  
**4**

ob. **2**  
**4**

cl. **2**  
**4**

mf *piuf* *sfz* *sim.*

**3**  
**8**

**2**  
**4**

hn. *sfz pp* *f* *f* *sfz* *sim.*

tbn. *con. sord.* *sfz* *mf* *piuf* *sfz* *sim.* *f*

$\text{♩} = 72$

Pc. *xyllo* *sfz* *mf* *sfz*

vn. **2**  
**4** *sfz* *sfz* *sim.* *arco.* *f* *pi33*

cb. **2**  
**4** *sfz* *sfz* *sim.* *arco.* *f* *pi33*

**3**  
**8**

**2**  
**4**

fl. **2**  
**4**

ob. **3**  
**4**

cl. **2**  
**4**

*sfz pp* *f* *f* *ff*

*tr.* *tr.* *tr.* *tr.*

*f* *5* *ff*

*Piu Mosso*

hn. *sfz pp* *f* *f* *ff*

tbn. *sfz pp* *f* *f* *ff*

*tr.* *VIB* *v.v.*

*Piu Mosso*

Pc. *P* *f* *ff*

vn. **3**  
**4** *arco* *f* *ff*

cb. **3**  
**4** *arco* *f* *ff*

*arco* *f* *ff*

Piu Mosso

MOLTO MARCATO (Tutti)

12

fl.

ob.

cl.

**A**

2

4

STRIDENT!

ff

Molto Marcato (Tutti)

hn.

tbn.

senza sord.

f

ff

GLISS

Piu Mosso

Pc.

vib.

l.v.

BONGOS

(Bongo)

PPP

ff

MOLTO MARCATO (Tutti)

12

fl.

ob.

cl.

**A**

2

4

GLISS

f

ff

SENZA MISURA

17

fl.

ob.

cl.

Sim.

TUTTI.  
except Cb.

hn.

tbn.

TO LOW GONG

Pc.

l.v.

pp

17

fl.

ob.

cl.

mp sempre.

♩ = 72

rall . . . .

♩ = 60

18 **Picc** **B**

fl. *p* *mp* *mf* *p*

ob. *p* *mp* *mf* *p*

cl. *p* *mp* *mf* *pp*

hn.

tbn.

♩ = 72

rall . . . . .

♩ = 60

Pc. (Gong) *v.v.* *mp* *Gemprz l.v.*

18 **B**

vln. *p* *pp* *pp* *pp* *pp*

cb. *pp* *pp* *pp* *pp* *pp*

24

picc *mp* *f* *mp* *mf* *mp* *mp*

ob. *p* *mp* *f* *mp* *mp*

cl. *mp* *f* *mp* *mp*

hn. *pp*

tbn. *pp*

Pc. *f* *mp* *mf* *mp*

24

vln. *pp* *pp* *mp*

cb. *pp* *pp* *mp*

Piu Mosso

♩ = 72

30

picc. p mp

ob. p mp

cl. mf mp mf mp mf

hn. p mp

tbn. p mp

Piu Mosso

♩ = 72

30

Pc. p mp mf

vl. mf mp mf

cb. p

SENZA MISURA

36

picc. p mp

ob. p mp

cl. p

hn. p

tbn. p

Pc. mf P 1/2 PEDAL (l.v.)

vl. p

cb. p

♩ = 60

♩ = 144 (♩ = 72)

5  
accel .....

38

picc. 2/4

ob. 2/8

cl. 2/8

change to Flute.

hn.

tbn.

Pc.

♩ = 60

to xylo. ||

♩ = 144

38

vln. 2/4

cb. 4/8

Sul. part. for

2/8

4/8

(pizz)

44 (accel) .....

♩ = 160

fl. 3/8

ob. 2/8

cl. 4/8

f

ff

sfz mf

hn.

tbn.

mp

sfz

sfz

accel. ....

♩ = 160

Pc.

f

sfz

f

ff

f

44

vln. 3/8

cb. 8/8

f

ff

pizz

[pizz]

arco

martele

mf

sfz









80

H

fl. **SENZA MISURA** TO ALTO FLUTE

ob.

cl. *molto marcato*  
ff **SENZA MISURA**

hn. *sfz* *mf*

tbn. *ff* *mp*

Pc. **SENZA MISURA**

80

H

vln. *molto marcato*

cb. *sfz ff* *mp*

(80)  $\text{♩} = 60$

3 4 2 4

afl. *mp*

ob. *mp*

cl. *mp*

hn. *mp* *P*

tbn. *mp*

Pc.  $\text{♩} = 60$

(80) 3 4 2 4

vln. *(non. dim.) mp*

cb. *mp*



117

af. f f f (mf) (mf)

ca. f f f f mp

cl. mp f mf (mf)

hn. f f f

tbn. f mf mp

Pc. (vib) pp f v.v. mp

117

vl. f f f f mf

cb. f mp

123

af. mp p change to flute

ob. change to oboe

cl. mp pp pp

hn. p con sord. [con sord]

tbn. con sord. pp [con sord]

Pc. p v.v. Xylo II pp

123

vl. mp p con sord. pp

cb. mp pp pp







152

fl.

ob.

cl.

hn.

tn.

Pc.

152

vl.

cb.

158

fl.

ob.

cl.

hn.

tn.

Pc.

158

vl.

cb.

**R**

SEGUE

SEGUE

SEGUE

GLOCK

VIB

GLISS

1.5''

1''

1''

1''

1''

1''

164

**S**

**SENZA MISURA**  
AS MANY REPETITIONS AS POSSIBLE

change to *Picc.*

fl.

ob.

cl.

15/2

**SENZA MISURA**  
as many repetitions as possible

hn.

tbn.

13

**SENZA MISURA**  
as many repetitions as possible

Pc.

164

**S**

**SENZA MISURA**  
as many repetitions as possible

vn.

cb.

86

86

♩ = 160

♩ = 120

165

**T**

**MOLTO MARCATO**

[Picc.]

picc.

6

8

ob.

4

8

cl.

5

8

4

8

**MOLTO MARCATO**

hn.

tbn.

**MOLTO MARCATO**

♩ = 160

♩ = 120

To BONGOS

Pc.

**MOLTO MARCATO**

165

**T**

6

8

vn.

4

8

5

8

4

8

arco

cb.

ACCEL ----- ♩ = 144

♩ = +160

169

U

picc.

ob.

cl.

4/8

2/8

4/8

(ff)

hn.

tbn.

TUTTA FORZA

meno

ff

ACCEL ----- ♩ = 144

♩ = +160

Pc.

3 BONGOS

BASS DRUM

TAM-TAM

T.T.

sfz

f

169

U

picc.

divco

cb.

4/8

2/8

4/8

pi33

pi33 b

sul pont.

molto sfz

TUTTA FORZA

fff

Poco RALL

♩ = 144

175

TO ALTO FLUTE

picc.

ob.

cl.

f

hn.

tbn.

mf

Poco RALL

♩ = 144

TAM-TAM

kv. partially dampen.

kv.

Pc.

mp

f

f

175

picc.

ob.

cl.

vn.

cb.

(pont)

ovd.

mf

181 V

fl. *mf* *f* *mf* *sfz p* *p*

ob. *mf* *f* *mf* *sfz p* *p*

cl. *mf* *f* *mf* *sfz p* *p*

hn. *mf* *f* *mf* *sfz p* *p*

tbn. *mf* *f* *mf* *sfz p* *p*

*tr Same pitch.*

*tr Same pitch.*

Pc. TO HIGH GONG *p* high gong *v.v.* TO \*XYLO *p* CHOKE!

181 V

vln. *f* *mf* *f* *mp* *p*

cb. *mp* *mf* *mp* *mf* *p*

*GLISS*

MOLTO RALL. ♩ = 50

187 W

fl. *p* *pp*

ob. *pp*

cl. *pp*

hn. *mf* *mp*

tbn. *pp*

187

Pc. *xylo.* # dampen bar whilst playing *mf* *pp* TO LOW GONG *mf* *v.v.* *mf* *(mf)* *VIBPP*

MOLTO RALL. ♩ = 50

187 W

vln. *p* *mp* *p* *con legno* *mf* *pp* *ord.* *con. sord.*

cb. *con legno.* *mf* *pp* *ord.*

192

af. ob. cl.

hn. tbn.

Pc.

192

vn. cb.

197

af. ob. cl.

hn. tbn.

$\text{♩} = 60$

senza vib

RALL - - - - -

Pc.

VIB pp

$\text{♩} = 60$

197

senza sord.

vn. cb.

RALL - - - - -

(RA:1) ----- LUNGA (MORENDO)

202

203

af. (mf)

ob. (mf)

cl. (mf)

hn. (mf)

tbn. (mf)

Pc. (mf)

(RALL) ----- LUNGA (MORENDO)

mf

LUNGA (MORENDO)

202

203

vln. (mf)

cb. mf

Michael P. Slon

fl.

ob.

cl.

hn.

tbn.

Pc.

vln.

cb.

# Michael Alcorn

## Calypso's Song To Ulysses

a setting of words by  
Adrian Mitchell

FOR PAM

Instrumentation

Soprano  
Alto Flute  
Soprano Saxophone  
Viola  
Double Bass  
1. Percussion  
    Vibraphone  
    Marimba  
    5 assorted cymbals  
    Crotales

### SEATING PLAN

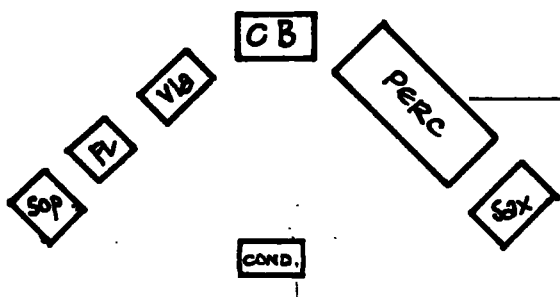

### PERCUSSION PLAN

STICKS    ○○○○  
          ○○○○  
          ○○○○  
          YY    Brushes  
          CB    Bow

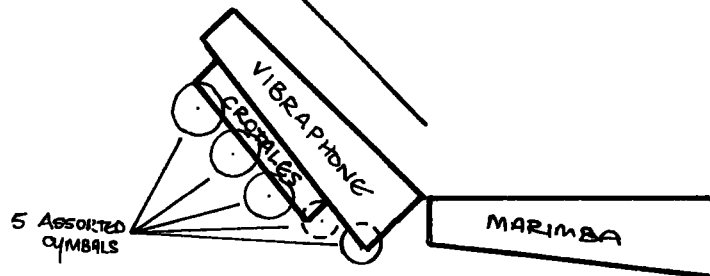

♪ = ♪ [SEMPRE]

SCORE NOTATED IN C

ACCIDENTALS APPLY THROUGHOUT BAR

CB. HARMONICS SOUND AT WRITTEN PITCH

'CIRCULAR BOWING' - MOVING BETWEEN

SUL PONT & SUL TASTO - GRADUAL TRANSITION.



### **Calypso's Song to Ulysses**

My hands are tender feathers,  
They can teach your body to soar.  
My feet are two comedians  
With jokes your flesh has never heard before.

So try to read the meaning  
Of the blue veins under my skin  
And feel my breasts like gentle wheels  
Revolving from your thighs to your chin.

And listen to the rhythm  
Of my heartbeat marking the pace  
And see the visions sail across  
The easy riding waters of my face.

What is sweeter than the human body?  
Two human bodies as they rise and fall.  
What is sweeter than two loving bodies?  
There is nothing sweeter at all.  
Lose yourself, find yourself,  
Lose yourself again  
On the Island of Calypso.

**Adrian Mitchell**

from *Ride the Nightmare*





15

A FL

SOP SAX

SOP

PERC

VLA

CB

with intense expression

pp

ord. #3

[Sonzamb] ord.

m (m) (m)\* m my hands [s] my hands are

5 16 ACCEL

3 4 A TEMPO

[\* ee sound]

TO CROTALES

TO VIB CB BOW

TO SIZZLE CB BOW

TO VIB/CB BOW

sul tasto

HARMONICS SOTTO VOCE

sul tasto

20

A FL

SOP SAX

SOP

PERC

VLA

CB

Piu Mosso

RALL

ten der tender feathers

[5] my

4 4

3 4

Piu Mosso

RALL

TO VIB + CROTALES

trm

sul tasto

25

A FL

SOP SAX

SOP

PERC

VLA

CB

A Tempo

Piu Mosso

hand are tender feath-ers

[6] They can teach your bo-dy to scan

A Tempo

Piu Mosso

trm

VIB + mp

2



44

A FL

SOP SAX

SOP

PERC

VLA

CB

your FLESH HAS NE-VER NE-VER HEARD [D]

3/4 2/4 3/4

pp mf p mf

48

A FL

SOP SAX

SOP

PERC

VLA

CB

Be-FORE

♩ = c56

2/4 2/16 3/4

pp mf pp mf pp mf

53

A FL

SOP SAX

SOP

PERC

VLA

CB

RALL

mf mp p

4



*♩ = 66*

A FL *tr* *poco rit*

SOP SAX

SOP

WHEELS

LIKE GEN-TLE

*♩ = 66*

4/4 3/4 2/4 4/4

OMBSALS PERC

VLA

CB

TO VIB

**E** *A TEMPO* *♩ = 75*

A FL

SOP SAX

SOP

WHEELS

WHEELS RE VOL VING

4/4 3/4

PERC

VLA

CB

# HARMONICS SOUND AT PITCH

TO CROTALES

*♩ = 96*

A FL

SOP SAX

SOP

RE VOL VING

*♩ = 96*

CROTALES

PERC

VLA

CB

TO CYMBALS YY

[Sensu vib]

83  $\text{♩} = 69$  **F** RALL

A FL

SOP SAX

SOP

PERC

VLA

CB

RE VOL VING RE

5 CYMBALS [FLEETING]

4/4 3/4 2/4 RALL

87 RALL  $\text{♩} = 66$

A FL

SOP SAX

SOP

PERC

VLA

CB

VOL VING FROM YOUR THIGHS TO YOUR CHIN

3/4 4/4  $\text{♩} = 66$

5 VIB

MEAD

PPP

PPP

PPP

91

A FL

SOP SAX

SOP

PERC

VLA

CB

VIB

3/4 2/4







♩ = 120 [H]

107

A FL

SOP SAX

SOP

AND

2  
4

4  
8

♩ = 120 [H]

PERC

VLA

CB

A FL

SOP SAX

SOP

SEE SEE THE VISIONS

PERC

VLA

CB

MOLTO RALLENTANDO

♩ = 90 [I]

115

A FL

SOP SAX

SOP

AND SEE THE VISIONS THE VISIONS SAIL SAIL

MOLTO RALLENTANDO

♩ = 90 [I]

PERC

VLA

CB

TO VIB

120

A FL

SOP SAX

SOP

SAIL A CROSS A CROSS THE ea sy THE

PERC

VLA

CB

2 3 2

trun

sfz

125

A FL

SOP SAX

SOP

ea sy R[DING] DING WATERS OF MY

PERC

VLA

CB

POSS RALL

molto

4

trun

sfz

130

A FL

SOP SAX

SOP

FACE

PERC

VLA

CB

TO MARIMBA

molto

10

4

♩ = 120

♩ = 120

134

A FL

SOP SAX

SOP

POCO RALL

PERC

VLA

CB

2/8

4/8

138

A FL

SOP SAX

SOP

RALL

4/8

ACCEL

ACCEL MOLTO

RALL

PERC

VLA

CB

SENZA VIB

MP

141

AFL

SOP SAX

SOP

PERC

VLA

CB

TO VIB

CON VIB



160  $\text{♩} = c56$

A FL

SOP SAX

SOP

WHAT IS SWEETER THAN TWO LO-VING BODIES THERE IS

$\text{♩} = c56$

PERC

VLA

CB

4  
4

165

A FL

SOP SAX

SOP

THERE IS NOTHING SWEETER AT ALL LOSE YOURSELF FIND YOURSELF

PERC

VLA

CB

ACCEL

RALL

169

A FL

SOP SAX

SOP

LOSE YOURSELF A GAIN

PERC

VLA

CB

13

173  $\text{♩} = \text{c}96$

A FL

SOP SAX

SOP

ON THE IS LAND OF CAL YP SO

$\text{♩} = \text{c}96$

PERC

VLA

CB

P133

177

A FL

SOP SAX

SOP

[so] THE IS LAND ON

PERC

VLA

CB

ARCO

P133

181

A FL

SOP SAX

SOP

OF IS LAND

POCO RALENTANDO

PERC

VLA

CB

ARCO

POCO RALL

185  $\text{♩} = c92$

A FL

SOP SAX

SOP

cal - yp - so

2  
8

4  
8  $\text{♩} = c92$

3  
8

TUTTI CRESCENDO POCO A POCO

PERC

VLA

CB

189

A FL

SOP SAX

SOP

CRESCENDO

f

SENZA MISURA

TO CUMBALS

3  
4

sfz

av. SLOW

PERC

VLA

CB

192  $\text{♩} = c48$

A FL

SOP SAX

SOP

3  
4  $\text{♩} = c48$  POCO RALL

PERC

VLA

CB

195

15