



Durham E-Theses

A study of methods of measurement of the electric charge on a rocket and of ambient electric fields using probe techniques

Edwards, Michael G.

How to cite:

Edwards, Michael G. (1962) *A study of methods of measurement of the electric charge on a rocket and of ambient electric fields using probe techniques*, Durham theses, Durham University. Available at Durham E-Theses Online: <http://etheses.dur.ac.uk/10090/>

Use policy

The full-text may be used and/or reproduced, and given to third parties in any format or medium, without prior permission or charge, for personal research or study, educational, or not-for-profit purposes provided that:

- a full bibliographic reference is made to the original source
- a [link](#) is made to the metadata record in Durham E-Theses
- the full-text is not changed in any way

The full-text must not be sold in any format or medium without the formal permission of the copyright holders.

Please consult the [full Durham E-Theses policy](#) for further details.

Academic Support Office, Durham University, University Office, Old Elvet, Durham DH1 3HP
e-mail: e-theses.admin@dur.ac.uk Tel: +44 0191 334 6107
<http://etheses.dur.ac.uk>

**H.G. EDWARDS B.Sc. DUNELM.
ST CUTHBERT'S SOCIETY.**

**A STUDY OF METHODS OF MEASUREMENT OF THE ELECTRIC CHARGE ON A ROCKET
AND OF AMBIENT ELECTRIC FIELDS USING PROBE TECHNIQUES.**

M.Sc. Thesis, Durham, 1962.

The copyright of this thesis rests with the author.
No quotation from it should be published without
his prior written consent and information derived
from it should be acknowledged.

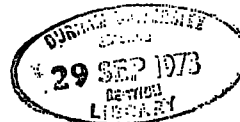

ABSTRACT.

A summary is given of literature on causes of rocket charge, ambient fields, and on probe techniques.

A variety of techniques are available for determining rocket charge, represented by a potential relative to space of 0 to 10 volts.

A cylindrical probe characteristic, analysed by the older Engel and Steenbeck methods, was obtained for a pulse discharge with a low electron concentration of 2×10^7 electrons/c.c. in the author's experiments.

The probe sheath was collision free, and conditions for such sheaths in the upper atmosphere are given.

The predicted ambient field is about .02 mV/cm, fields measured being .60 mV/cm (by a probe technique) and 200 V/m (by field meters).

The author's tentative opinion is that the ambient field might be measured by a simultaneous determination of potential at two points using probes.

Laboratory simulation seems to require a low voltage gradient discharge, (preferably with ions and electrons in thermal equilibrium,) because two probes cannot be placed as close as a Debye length.

The contract specifically excluded development of circuitry so a precise answer cannot be given, but definite proposals are made.

In the experiment, the measured voltage gradient was about 30 V/cm, which seems abnormally high at a discharge current of about 10^{-4} amps when compared with recent results for steady glow discharges.

The explanation may reside in the existence of striations. From the work recently reported in a Czechoslovakian journal^x it might be argued that the probe is responsible for the striations.

No material is included on re-entry physics, nor on the time and space variations of electric fields. A study of the latter should be related to a precise knowledge of the rocket motion.

The research represents a branch of Atmospheric Electricity which had not previously been studied at Durham.

^x Reference 59. Pekarek and Krejci, 1961.

**A STUDY OF METHODS OF MEASUREMENT OF THE ELECTRIC CHARGE ON A ROCKET
AND OF AMBIENT ELECTRIC FIELDS USING PROBE TECHNIQUES.**

INTRODUCTION.

SECTION I: SURVEY OF LITERATURE.

Page No.

Chapter 1. Charged Particles.

4

Appendix to Chapter 1:-

Extensions to the Discussion of Charge Motion.

20

Chapter 2. Conducting Fluids.

25

Chapter 3. Upper Atmosphere.

37

Chapter 4. Electric Fields.

48

Chapter 5. Probe Theory.

56

Appendix to Chapter 5:-

The Moving Hemisphere Current Equations.

77

Chapter 6. Rocket Flight.

80

SECTION II. ACCOUNT OF EXPERIMENTS.

95

Chapter 7. Vacuum Technique.

96

Chapter 8. Experimental System.

104

Chapter 9. Theoretical Discussion.

107

Appendix to Chapter 9:-

Note on Sheath Collisions.

111

Note on Probe Location.

112

SECTION III. METHODS OF MEASUREMENT.

113

Chapter 10. Design Criteria.

113

REFERENCES.

A STUDY OF METHODS OF MEASUREMENT OF THE ELECTRIC CHARGE ON A ROCKET AND OF AMBIENT ELECTRIC FIELDS USING PROBE TECHNIQUES.

SUMMARY OF THE THESIS.

1. Previous Work.
2. Experimental System.
3. Experimental Results.
4. Analysis of Results.
5. Laboratory Simulation.
6. Ambient Fields.
7. Definite Proposals.

PREVIOUS WORK.

A summary of some of the literature relating to the causes of the electric charge on a rocket and of the ambient electric fields which it encounters was undertaken. From a reference list supplied by Dr R.L.F. Boyd and other material a summary of some of the literature relating to probe techniques was also attempted. These constituted the main part of the work.

It appears that a variety of techniques are available for determining the rocket charge, represented by a potential relative to space of between 0 and 10 volts.

EXPERIMENTAL SYSTEM.

A 2000 volt peak pulse was obtained from a circuit with a time constant of 80 seconds and used to break down a 25 cm column of air at a pressure of 10^{-4} atmospheres. The air column sustained a total voltage of 470 volts. A cylindrical tungsten probe of surface area $\pi/20$ cm² was placed in the mid-point of the column to measure the potential there relative to the anode. The characteristic (see figure 47) was analysed by the older methods described in Engel and Steenbeck (1932), which are thus, incidentally, made available in English. The analysis is represented by figures 51 and 52.

EXPERIMENTAL RESULTS.

The potential at the mid-point of the column was determined as 128.5 volts; the current density as 2×10^{-4} amps/cm²; and the electron concentration as 2×10^7 electrons/cc. Collisions do not occur in the sheath, because the percentage ionisation is twenty times the critical value as estimated from a formula believed to be original. The critical values of ionisation in the upper atmosphere determined in the same manner are shown in figure 53 which suggests

that collisions do not occur between about 100 and 400 kms.

ANALYSIS OF RESULTS.

From the results obtained it appears that the discharge current is of the order of 10^{-4} amps and that the free column voltage gradient is ^{about} nearly 30 V/cm.

An extrapolation over a pressure range of 10^4 , using the appropriate proper variables, of the free column gradients (10^{+3} V/cm) quoted by King (1961) for a current of 10^{-4} amps at atmospheric pressure suggest that the measured gradient is abnormally high, but this may be explained by the effects associated with the striations. (In point of fact the probe structure may have been responsible for the existence of striations which occur only on the anode side of the probe, although the positive column extends well towards the cathode. This hypothesis is based on the theory of striations given by Pekarek and Krejci ... 1961.)

But even the normal gradients are high compared to the minimum measured fields obtaining in the Upper Atmosphere.

Although the matter is not discussed elsewhere in this thesis, it is of interest to record that with high currents a self-rotating arc was observed. This is apparently a rarely observed phenomenon, but a study of it was, of course, quite outside the scope of the present work.

LABORATORY SIMULATION.

The problem of simulation in order to test ambient field measuring equipment seems to reside in producing a low voltage gradient discharge (in which the ions and electrons are in thermal equilibrium). This arises as a consequence of the disturbance which probes very near to each other would create in a discharge, and of the low voltage gradient which exists in the ionosphere. The electric field in the upper atmosphere has been predicted to be .02 mV/cm and fields as low as .60 mV/cm have been measured.

AMBIENT FIELDS.

Present work has completely neglected the high ambient fields of the order of 10,000 V/m associated with the re-entry of the rocket into the atmosphere.

Fields of the order of 200 V/m as measured with field meters on a rocket might be measured by a simultaneous determination of the potential at points of the order of 10 meters apart using probe techniques. The characteristic

obtained by the author as described above shows that an error in the space potential of 5 volts is possible in using the characteristic itself and the curves obtained by Boyd and Twiddy (1959) show that an error of 0.1 volts is possible using the semilogarithmic plot. Clearly, to distinguish between two probe characteristics requires refined circuitry (in the rocket) and is not possible at the lower value of field obtaining in the Upper Atmosphere.

DEFINITE PROPOSALS.

The technique proposed is a familiar one in space experimentation, so there is no need to make a design study apart from the development of new circuitry to compare the characteristic differentials. Even if no information is obtained about ambient fields, a trial would not be unprofitable, as it should be quite easy to arrange matters so as to obtain the information normally available from rocket-borne probes. The contract specifically excluded the development of circuitry. However, this branch of the subject is well developed and the first Anglo-American Satellite, for example, has circuits for measuring the first and second derivatives of the current to a probe.

INTRODUCTION

The motion of charged particles is ultimately responsible for the presence of electric fields in the ionosphere. This motion also determines the behaviour of any device which simulates the upper atmosphere, and also the behaviour of any instrument used to measure ionospheric electric fields. The basic theory concerning charge motion is given first for the case of a charged particle which is moving in a uniform magnetic field but subject to various perturbations, (such as the presence of an electric field), and then for the case of a weakly ionized gas in which the motion is largely controlled by collision with neutral particles, and finally for the case of a highly ionized gas in which the motion is controlled by space charge fields. The basic equations for macroscopic motion in a fully ionized gas are shown to be consistent with the idea that electrical neutrality is preserved for a suitable model of the atmosphere.

Electrically conducting fluids are discussed broadly in order to contrast various systems which can be obtained in the atmosphere and laboratory. The reason for turning attention to this is that the study of atmospheric systems with rockets is far more expensive than laboratory studies, so that ideas and equipment for atmospheric work must receive preliminary tests in analogous laboratory systems.

The variation with height of the mechanical and electrical properties of the upper atmosphere are described in terms of the ARDC model atmosphere. The existence of the ionosphere is explained, and matters such as scale height, penetration frequency, and the measurement and explanation of electron profiles are discussed.

Before the advent of extensive rocket research information concerning electric fields in the upper layers of the atmosphere was almost completely lacking. Data on electric fields was urgently needed for the solution of many problems, such as the nature of solar particles. The theory of the origin of ionospheric electric fields

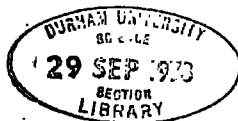

is presented, and the idea of an electric current system in the upper atmosphere due to tidal movements of conducting air across the earth's magnetic field is described. Graphs are given of the electric field in the upper atmosphere computed according to theory. The total field is predicted to be of the order of 2×10^{-5} V/m. (See page 55).

A summary is given of the early work on probe theory, done by Langmuir and his associates in the Research Laboratory of the General Electric Company at Schenectady, and of recent work on probes which Boyd and his collaborators have carried out at University College, London. The space potential is not well defined because of the disturbance of the plasma when a probe is drawing a large electron current, which happens when it is near the space potential. The true space potential lies positive to the inflexion point on the current-voltage characteristic because of the probe disturbance.

The author acknowledges the valuable help obtained from letters, discussions and visits, and conferences. These have made it possible to determine how the material available applies when one turns to the task of making measurements on a rocket. The electric fields so far measured are considerably higher than those predicted on theoretical grounds.

So far we have only been concerned with a survey of relevant literature. Simple experiments have been carried out which have led to a deeper understanding of this literature. Vacuum technique, the most preoccupying part of the experimental study, is described in an easy reference form. The theoretical discussion of the results presents the Engel and Steenbeck theory for the use of cylindrical probes and applies this to the results at hand. The author has given a theory of sheath collisions and probe location in order to fill apparent gaps in the literature.

The conclusions of the work are presented as a number of design criteria for the experimental apparatus required. It has not been

possible to make progress beyond this, largely because the topic of study is a new one to the department where research has been carried out. Accordingly, one of the aims of this work is to introduce the subject to newcomers.

ACKNOWLEDGEMENTS.

The great help given by Dr J.A.Chalmers and Dr W.C.A.Hutchinson throughout the research programme is acknowledged.

The author would like to thank Professor G.D.Rochester for the opportunity of undertaking research, the United States Air Force for the provision of a grant, Dr W.C.A.Hutchinson for his assistance with the thesis, and Miss W.Andrews for doing the typing.

The work has gained in interest as a result of working alongside Mr P.J.L.Wildman, who has made a companion study of the same problem using different techniques.

Note 1.

The M.K.S. system of units has been used throughout this work, except where otherwise indicated.

Note 2.

A.R.D.C. refers to the United States Air Force Air Research and Development Command.

**A STUDY OF METHODS OF MEASUREMENT OF THE ELECTRIC CHARGE ON A ROCKET
AND OF AMBIENT ELECTRIC FIELDS USING PROBE TECHNIQUES**

SECTION 1. SURVEY OF LITERATURE.

CHAPTER 1. CHARGED PARTICLES.

	Page No.
SUMMARY - THE MOTION OF CHARGED PARTICLES.	5
1. CHARGED PARTICLES IN ELECTRIC AND MAGNETIC FIELDS.	6
a. Equations of motion.	6
b. Particle Drifts.	7
c. Invariants of the Motion.	8
d. Magnetic Moment.	8
e. Acceleration of Particles.	9
2. MOTION IN PARTIALLY IONIZED GASES.	9
a. Average Velocity, Pressure and Temperature.	9
b. Maxwell's Distribution Law.	10
c. Knudsen's Cosine Law.	11
d. Mean Free Path.	12
e. Energy Transfer in Particle Collisions.	12
f. Collision Cross Sections.	12
g. Mobility of Ions in an Electric Field.	13
h. Diffusion.	13
3. MOTION IN HIGHLY IONIZED GASES.	14
a. Debye Length.	14
b. Plasmas. (Low Pressure).	16
c. Particulate Processes.	17
d. Electrically Neutral Atmosphere.	18
APPENDIX - EXTENSIONS TO DISCUSSION OF CHARGE MOTION.	20

CHAPTER 1. CHARGED PARTICLES.

THE MOTION OF CHARGED PARTICLES.

The motion of charged particles is ultimately responsible for the presence of electric fields in the ionosphere. This motion also determines the behaviour of any device which simulates the upper atmosphere, and also the behaviour of any instrument used to measure electric fields in the ionosphere. Accordingly, the basic theory concerning charge motion is presented in this chapter.

In the case of a charged particle which is moving in a uniform magnetic field, the path of motion is a helix of constant pitch around a line of force. But there are various perturbations, such as the presence of an electric field, which cause particle drifts to be superimposed on this motion. It is of interest to note that if the magnetic moment is a constant of the motion of the particle it is possible to explain, for example, the cosmic acceleration of charged particles.

In a gas which is partially ionized, the motion of charged particles is largely controlled by their collisions with neutral particles. An electric field has the effect of producing a drift of the particles.

In fully, or highly, ionized gases the motion is controlled by space charge fields. It is important to consider the contrapolar ionic atmosphere about each of the ions, and also the unipolar charge sheaths which develop at the boundaries of the gas.

If in any small volume there is overall electrical neutrality the name plasma is applied to the gas. In such a plasma collective interactions are possible, such as the particle drifts we considered at the beginning. The motion of the particles is also controlled by mutual Coulomb electrostatic fields.

The basic equations for macroscopic motion in a fully ionized gas are consistent with the idea that electrical neutrality is preserved for a suitable model of the atmosphere.

The distinction between the microscopic drift velocities of charged particles and the macroscopic velocity used in these equations is made clear.

1. CHARGED PARTICLES IN ELECTRIC AND MAGNETIC FIELDS.

a. EQUATIONS OF MOTION.

The acceleration of a particle of mass m kgm and charge Ze coulombs in the presence of an electric field (E V/m) and magnetic induction (B Wb/m²) is given (Spitzer, 1956) by:-

$$m \frac{d\mathbf{v}}{dt} = Ze (\mathbf{E} + \mathbf{v} \times \mathbf{B}) \quad \dots \text{Equn. 1.}$$

where \mathbf{v} is the particle velocity in m/sec. This equation is in vector notation.

Use is sometimes made of an expression for the angular frequency of a particle which describes a circular path in a uniform magnetic field. It may be derived from equation 1 and is given by:-

$$qB/m = ZeB/m = \omega_p/a \quad \dots \text{Equn. 2.}$$

where Z is the particle charge in units of the electron charge, e is the charge on an electron, ω_p is the component of the velocity \mathbf{v} at right angles to B , and a is the radius of the circular path.

For example, in a uniform magnetic field in the absence of an electric field, the particle path will be a helix of constant pitch around a line of force.

b. PARTICLE DRIFTS.

The motion of a particle may be regarded (Spitzer, 1956) as a drift superimposed on the motion in a helical path. Particle drifts are caused by various perturbations such as the presence of an electric field, a spatial inhomogeneity in the magnetic field, or slow changes of the magnetic field with time. In the presence of electric and magnetic fields a particle will circle about a point (called the guiding centre) which is moving. Drift is the motion of the guiding centre transverse to the magnetic field.

An electric field produces a drift velocity $w_d = E_p/B$ where E_p is the component of E at right angles to B . If B is thought to come out of the paper with E towards the top of the page, then the drift is to the right. For an observer moving at the velocity w_d , the electric field has been transformed away. Such a drift does not produce separation of positive from negative charge.

Here there is only space to state the results. The derivations are given for instance in the first chapter of Spitzer (1956).

Because we are concerned with charge motion in the atmosphere, we must also consider the drift velocity due to a gravitational field. This is given by $w_d = mg_p/qB$ where g_p is the component of the acceleration due to gravity which is perpendicular to B . The direction of the drift now changes with the sign of the particle's charge, hence there is a separation of charge. (But see Section 3d: Electrically Neutral Atmosphere).

The magnetic field of the earth is not uniform in either time or space. A spatial inhomogeneity in the magnetic field means that the radius of curvature changes as the particle rotates. The drift caused by this produces a charge separation. Curvature of the field lines produces a centrifugal acceleration and leads to charge separation also.

c. INVARIANTS OF THE MOTION.

Restrictions are placed on equation 1 above in deriving drift velocities. They are equivalent (Post, 1959) to:-

(1) Fractional variations in the magnetic and electric fields shall be small over the diameter of the particle orbit.

(2) The fractional variations shall be small during the rotation period of the particle.

Under these conditions, not only are the expressions for drift velocity true: the magnetic moment M of a particle is an invariant of its motion. The magnetic moment does not change if B changes with time but is uniform throughout space. When B varies along the particle path but is constant with time at each point, M is again constant.

d. MAGNETIC MOMENT.

The magnetic moment of a current I encircling an area S equals IS . The unit of magnetic moment has not been generally agreed upon, as some writers prefer to define it by means of the equation which makes H the force vector for a magnetic dipole instead of B . With the latter definition the unit is weber-metre. With the definition used in this survey, the unit of magnetic moment is ampere-metre².

For an electron circling in a magnetic field, the magnetic moment M is given by:-

$$\underline{M} = na^2 q/T_m = \frac{1}{2}mw_p^2/B \dots \text{Equn. 3.}$$

where the only new symbol is T_m , the particle rotation period in a magnetic field given by equation 2. It follows from this that B is proportional to w_p^2 .

So long as the magnetic moment is invariant, each charged particle in moving through a varying magnetic field maintains a

x constant flux ($\int B \cdot dS$) through its helical orbit circle.

The constancy of the magnetic moment has the immediate result that circling particles will tend to be reflected from regions of increasing magnetic field. The derivation of this result is given in Spitzer (1956).

e. ACCELERATION OF PARTICLES.

All this is of interest partly because regions of increasing magnetic field occur in the atmosphere of the earth. This will be considered later on in connection with the van Allen radiation belts, this survey being intended to include background information on the electrical state of the earth's atmosphere. The following example (Spitzer, 1956) illustrates the importance of the conclusion about the behaviour of particles in regions of increasing magnetic field.

The theory of origin of cosmic rays is concerned with the cosmic acceleration of charged particles. The high conductivity of ionized gases in the stars and interstellar clouds limits the value which electrostatic fields can have. If the magnetic field in two interstellar clouds, moving towards each other, is greater than in the intervening region, particles trapped between these two "magnetic mirrors" gain energy on each reflection. Alternatively charged particles in space may be accelerated if the magnetic field increases with time.

2. MOTION IN PARTIALLY IONIZED GASES.

a. AVERAGE VELOCITY, PRESSURE AND TEMPERATURE.

In a gas which is partially ionized, the motion of charged particles is largely controlled by their collisions with neutral particles. According to the kinetic theory of gases all the particles are in motion and the energy and pressure of each species of particle can be expressed in terms of some kind of average velocity.

Suppose that n is the number of particles per unit volume (i.e. per cubic metre). Then we can define a "root mean square" velocity (cm/sec) for the particles:-

$$c^2 = \frac{1}{n} \sum n_i c_i^2 \quad \dots\dots \text{Equn. 4.}$$

where there are n_i particles with velocity c_i .

The pressure can be expressed in terms of this velocity:-

$$p = \frac{1}{3} n m c^2 \quad \dots\dots \text{Equn. 5.}$$

The unit of pressure in this equation is newton/m². Atmospheric pressure (760 mm Hg) is 10⁵ N/m² for a working value. More exactly it is 1.06 x 10⁵ N/m².

If there are (3 + x) degrees of freedom, the mean energy in joules of a particle is given by:-

$$\left(\frac{3+x}{2}\right) \frac{1}{2} m c^2 = \left(\frac{3+x}{2}\right) \frac{3}{2} kT \quad \dots\dots \text{Equn. 6.}$$

It should be noted that the average energy of a given species of particle can be expressed in terms of a kinetic temperature, T°K. The energy E is expressed in joules. For T = 290°K, the energy kT = 4 x 10⁻²¹ joules, since k = 1.38 x 10⁻²³ joules/°K.

b. MAXWELL'S DISTRIBUTION LAW.

The above relations are of great importance in almost any consideration of the behaviour of gases. In general a gas will consist of a mixture of charged and uncharged species of particles. For some purposes it is convenient to suppose that there is just one species of neutral particle together with its positive ion and electrons. The way in which the velocity of the particles is distributed is also a matter of great importance. Quite often the velocities of the particles are either known or assumed to be distributed according to Maxwell's Distribution Law (Cobine, 1931). Figure 1 shows this

Figure 1. Maxwellian Velocity Distribution.

To face page 11.

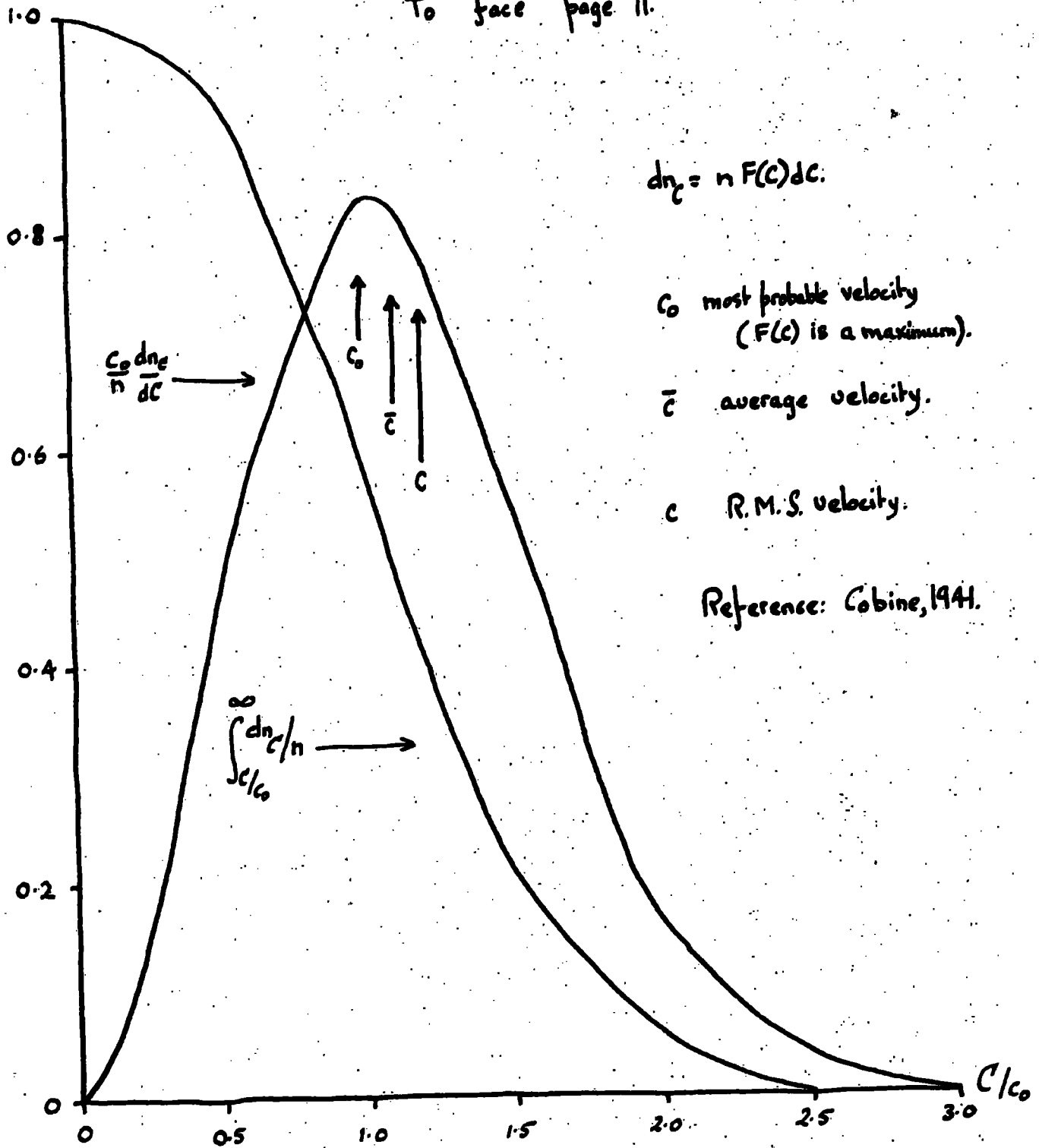

$$dn_c = n F(c) dc.$$

c_0 most probable velocity
($F(c)$ is a maximum).

\bar{c} average velocity.

c R.M.S. velocity.

Reference: Cobine, 1941.

distribution in two convenient forms.

Suppose that the velocity distribution is given by a function $F(C)$ so that the number density of particles with velocities in the range C to $(C + dC)$ is given by:-

$$dn = n F(C) dC \quad \dots \text{Equn. 7.}$$

where n is the total number density of particles, so that $\int F(C) dC = 1$, taken over all velocities. It is then possible to show that the average velocity \bar{c} is given by:-

$$\frac{1}{n} \int n_i c_i = 2/(\pi h)^{1/2} = \bar{c} \quad (h = m/2kT) \quad \dots \text{Equn. 8.}$$

and that:-

$$c^2 = 3kT/m \quad \dots \text{Equn. 9.}$$

Figure 1 shows the average velocity defined by equation 8, the most probable velocity, and the R.M.S. velocity (equation 9).

Because of equation 9 it is customary to use the expressions "mean velocity" and "kinetic temperature" as if they were synonyms.

Morse, Allis and Lamar (1935), considering the motion of free electrons among the atoms of a gas assume either: (i) Electrons lose no energy on collision with the atoms. So at any point all electrons have the same energy. This is valid when the electron free path is greater than the dimensions of the apparatus. Or (ii) the electron velocities have a Maxwellian distribution and the density and temperature can vary from point to point. This is valid when the electrons are in temperature equilibrium with the gas, or when there is available some mechanism for transferring energy directly from electron to electron.

c. KNUDSEN'S COSINE LAW.

The total number of particles per second that come down on an area dS in the solid angle $d\phi$ inclined at an angle θ to the normal to the area dS is $dS n \bar{c} \cos \theta d\phi/4\pi$. Hence the total number of particles

Figure 2. Mean Free Path.

To face page 12.

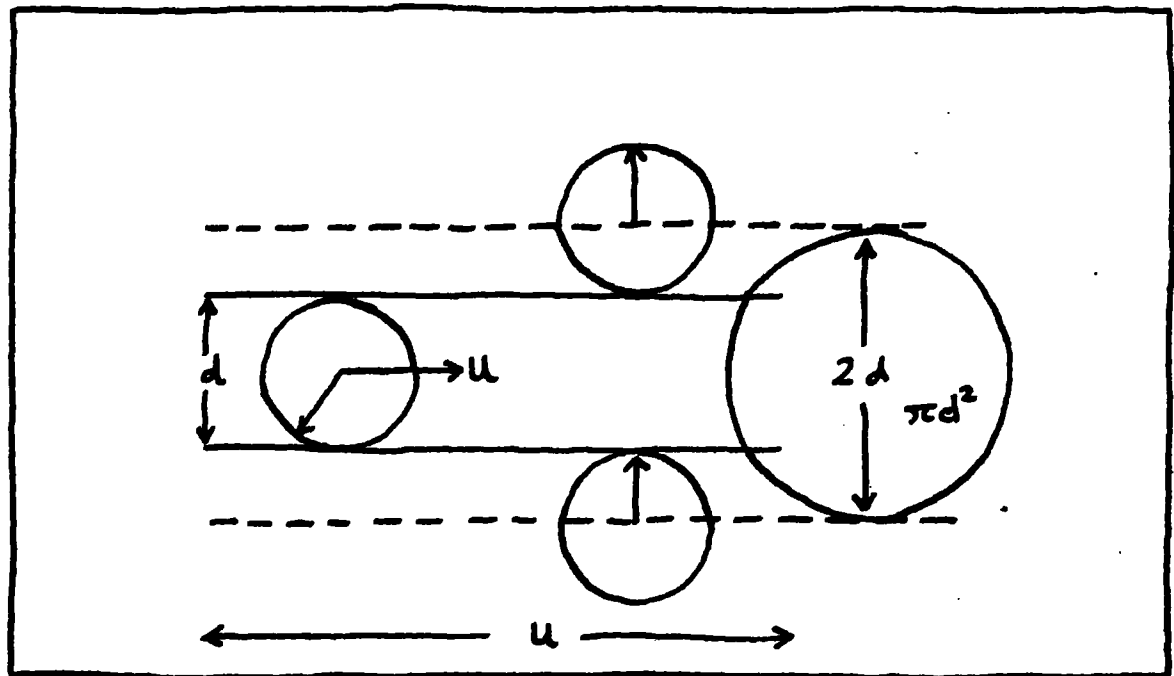

If only one particle were moving, and if its velocity were u , the number of collisions per second would be $n u \pi d^2$ where d is the diameter of the particles.

The mean free path would be given by

$$\lambda = u / n u \pi d^2 = 1 / n \pi d^2$$

coming from one side per second per unit area is $\frac{1}{4} n\bar{c}$. This relation and the other equations developed above are used in chapter 5 on probes.

d. MEAN FREE PATH.

Where d is the diameter of the particles, the mean free path (see figure 2) is given by:-

$$\lambda = 1/n\pi d^2 \quad \dots\dots \text{Equan. 10.}$$

The random motion of all the molecules is allowed for by using $\lambda_m = \lambda/(2)^{\frac{1}{2}}$. An electron, because its diameter is negligible in comparison with that of a molecule, has a mean free path given by $\lambda_e = 4\lambda$, where λ is defined by equation 10. We might expect it to be given by $\lambda_e = 4\lambda_m$. This latter expression is wrong because the velocity of the molecules is negligible in comparison with that of the electrons, as we shall see immediately below.

e. ENERGY TRANSFER IN PARTICLE COLLISIONS.

It is important to recognise that the average loss of energy by an electron in an elastic collision with a molecule is very small. This explains why it is possible for the mean temperature and velocity to be higher for the electrons than for the gas.

Consider a particle (mass m_1 , velocity u_1) colliding with another particle (mass m_2) at rest and subsequently moving off with a new velocity (U_1). The velocity (U_2) acquired by the second particle (mass m_2) is given by:-

$$dV = \frac{1}{2}m_2U_2^2 = \psi \cdot 4m_1m_2/(m_1 + m_2)^2 \quad \dots\dots \text{Equan. 11.}$$

where $\psi = \frac{1}{2}m_1u_1^2$. This is derived from the conservation of energy and momentum equations. If m_1 refers to an electron, m_2 to a molecule, then the fractional loss of energy dV/V is seen to be small.

f. COLLISION CROSS SECTIONS.

If there are n particles per unit volume, each of cross sectional area $\pi d^2/4$ then:-

$$I_x = I_0 \exp(-\gamma x), \quad \gamma = nnd^2/4 \quad \dots \text{Equn. 12.}$$

where I_0 is the incident particle intensity per unit area, I_x the intensity after a distance x , γ the absorption coefficient (Townsend, 1947).

The probability (P) of making a collision in unit distance would be $nnd^2/4$ if the particles were so tenuously distributed that each collision made no difference to the others. The number of collisions made by a particle per metre is $P = nnd^2/4 = 1/\lambda_m$, using equation 10. This provides an alternative approach to the concept of mean free path.

Suppose $Q(C_e)$ is the collision cross sectional area for electrons having a velocity C_e . Q has a minimum at some low electron energy. Let n_e be the electron concentration, f_e the electron collision frequency, n_m the number of heavy particles, and let the number of electrons with velocities in the range C_e to $C_e + dC_e$ be $n_e F(C_e) dC_e$. Then:-

$$n_e f_e = n_m \int n_e F(C_e) Q(C_e) C_e dC_e \quad \dots \text{Equn. 13.}$$

Experiments on the drift velocity of electron clouds in air under weak electric fields at energies between $1/30$ eV and $1/3$ eV give f_e .

$f_e = 8.7 \times 10^5 p$ collisions per second, where p is the pressure in newtons/m².

g. MOBILITY OF IONS IN AN ELECTRIC FIELD.

An electric field produces a drift of particles in a partially ionized gas. The average time between collisions is given by λ/\bar{c} . The average velocity acquired in the presence of an electric field is $\frac{1}{2}eE\lambda/m\bar{c}$. The mobility U is defined so that, (Townsend, 1947):-

$$U = \frac{1}{2}e\lambda/m\bar{c} \text{ (metres/sec)/(volts/metre)} \quad \dots \text{Equn. 14.}$$

h. DIFFUSION.

Particles may be lost from a region by the process of diffusion (Osakam, 1957). There must be a gradient of concentration, ∇n . Consider diffusion in one direction (x). The diffusion length (L metres) is defined by:-

$$\frac{dn}{dx} = \frac{n}{L} \quad \dots \text{Equn. 15.}$$

The diffusion coefficient ($D \text{ m}^2/\text{sec}$) is defined by:-

$$n \frac{dx}{dt} = -D \frac{dn}{dx} \quad \dots \text{Equn. 16.}$$

where dx/dt is the diffusion velocity.

The variation of concentration with time is given by:-

$$\frac{dn}{dt} = -Dn/l^2 \quad \dots \text{Equn. 17.}$$

The net force on one particle giving rise to diffusion may be denoted by F . If the collision frequency is f , the time between collisions is $1/f$. Hence $dx/dt = \frac{1}{2}F/mf$. But $dx/dt = f\lambda$. Combining these we have:-

$$\frac{dx}{dt} = (\lambda F/2m)^{\frac{1}{2}} \quad \dots \text{Equn. 18.}$$

So the diffusion velocity of the electrons is large compared to that of the ions on account of their very different masses. The electrons will therefore build up a negative space charge in the outer parts, and will leave a positive space charge in the inner parts of the ionized gas. In the case of very low charge densities, this space charge is small: its influence on the motion of the charged particles can then be disregarded, so as to have electrons and ions moving by pure diffusion. The free diffusion relations above then hold.

Equation 16 can be put in this form:-

$$\frac{dx}{dt} = -D/n \frac{dn}{dx} = \frac{1}{2}F/mf \quad \dots \text{Equn. 19.}$$

This equation is used in the chapter on the Upper Atmosphere. (See page 44).

Another point to note about free diffusion is that a magnetic field largely prevents diffusion across the lines of force.

Diffusion can be checked by the use of helium at a comparatively large pressure as a passive recoil agent.

3. MOTION IN HIGHLY IONIZED GASES.

a. DEBYE LENGTH.

In the case of high charge densities free diffusion is prevented

by fields due to the space charges (Oskam, 1957). The net fields built up will retard the electron diffusion, but will accelerate the positive ion diffusion until the electrons and ions move with one and the same average velocity. Under these circumstances the difference of the densities of the charged carriers of opposite sign causing the space charge fields is small compared to the density of each individual charge carrier: the plasma is said to be "quasi-neutral". This diffusion influenced by space charge is called "ambipolar diffusion" and the diffusion coefficient denoted by D_{12} . For a mixture of electrons and positive ions $D_{12} = 2D_+$ since the average mass is $\frac{1}{2}m_+$.

In an electrolyte, the drift of ions is opposed by an asymmetric "ionic atmosphere". Similarly, in gases the field of a stationary ion is proportional to $\exp(-r/\lambda_D)$. This is the effect of shielding by contrapolar ions, which reduce the field by $(1/e)$ in a distance $r = \lambda_D$.

If the dimensions of the vessel containing the gas are much greater than λ_D , called the Debye length, then the ions hold their shielding electrons, the diffusion is ambipolar, and the gas is called a plasma. If the dimensions are much less than this critical length, the diffusion is free.

The Debye length can be defined (Allis, 1956) in terms of diffusion and mobility coefficients:-

$$\lambda_D = (\epsilon_0 D_e / n_e e U_e)^{\frac{1}{2}} \quad \dots \text{Equn. 20.}$$

The ration D/U is of the order kT/e . (This is consistent with para. 2g and 2h). Hence the Debye length is:-

$$\lambda_D = (\epsilon_0 k)^{\frac{1}{2}} / e \times (T_e / n_e)^{\frac{1}{2}} \quad \dots \text{Equn. 21.}$$

where $\epsilon_0 = 8.85 \times 10^{-12}$ farad/metre and n_e is the electron concentration (metres⁻³). A working formula is $\lambda_D = 69.0 (T_e / n_e)^{\frac{1}{2}}$ metres.

Although the precise applicability to an ionized gas of Debye's result; which was derived for electrolytes, is open to question, the Debye shielding distance λ_D is clearly a measure of the distance over which n_e can deviate appreciably from Zn_+ , under conditions where the electrical potential energy per electron does not exceed the mean thermal energy. If, in a distance λ_D , the potential energy W of an electron changes by an amount $\frac{1}{2}kT$, then Poisson's equation leads to the result:-

$$\epsilon x \quad dW = \frac{n_e e^2 \lambda_D^2}{2\epsilon_0} = \frac{1}{2}kT$$

which is consistent with equation 21 (Spitzer, 1956).

b. PLASMAS.(LOW PRESSURE).

In a plasma there are high, approximately equal, concentrations of positive and negative charge. The negative carriers are actually electrons as negative ions quickly recombine. The electron temperature is greater than the positive ion temperature, which is in turn greater than the gas temperature. Ion and electron velocities are often assumed to have a Maxwellian distribution. The actual distribution can be found using probes (see chapter 5, paragraph 2a). If an electric field is applied to a plasma, a drift current density is obtained which is very much less than the random current density. In other words, the positive ion temperature, and electron temperature increase, but the shape of the velocity distribution is not altered. The electron temperature increases more than the ion temperature because of the greater electron mobility. There is little transfer of energy from the electrons because of their small mass. The positive ions do increase the gas temperature. The ionization of a plasma can be maintained by electron collisions and by photoionization. The average micro electric field due to a particle (which would of course be reduced by space charge effects) is several times the field required to maintain the plasma (Gobine, 1941).

c. PARTICULATE PROCESSES.

In a high temperature plasma (kinetic temperatures of 10^7 °K) there are all the following processes taking place (Post, 1959). There are collective interactions - particle drifts (paragraph 1b of this chapter) under electric, magnetic, and gravitational fields: and there are particulate processes. These particulate processes include ionization (collisions between electrons and neutral atoms): charge exchange (ions capturing electrons from neutral atoms): and cooling mechanisms (such as inelastic collisions of electrons with nuclei and excitation radiation): and Coulomb collisions. It is proposed to discuss only the last of these.

It is convenient to suppose that a particle is surrounded by a sphere of radius λ_D , and to call this the Debye sphere. The elastic scattering arising from the mutual Coulomb electrostatic fields of the charged particles leads to a deflection of the particles and to an exchange of energy. This determines the basic rate of all collisional transport processes. Collective interactions take place with particles lying outside the Debye sphere, while very close collisions lead to large discontinuous deflections or energy exchanges.

In the intermediate region, deflection or energy exchange is a continuous process arising from the integrated effect of small but uncorrelated "collisions" with the many particles which are "distant" but within the characteristic distance λ_D . These distant collisions are an order of magnitude more important than close collisions in producing deflections between particles of equal mass. It is one of the weaknesses of present plasma theory that it treats the collisional interactions between a given charged particle and each of its many neighbours within a Debye sphere as separate, uncorrelated "events", even though many such events may be occurring simultaneously. It is for this reason that the number of particles within a Debye sphere is of interest.

In addition to encounters between like particles, the electrons of a plasma can substantially influence the energy of plasma ions by collisional interactions, because of their greater mobility.

d. ELECTRICALLY NEUTRAL ATMOSPHERE.

Dynamical equations for average velocity and current, \underline{v} and \underline{j} (defined below), can be written, the terms of which have the dimensions newtons/cubic metre. If \underline{v} does not vary with time we have:-

$$(\underline{j} \times \underline{B}) - \text{grad } p - (d \text{ grad } G) = 0 \quad \dots \text{Eqn. 22.}$$

where p = scalar pressure: d = density = $n_+ m_+ + n_e m_e$; G = gravitational potential: $\underline{j} = e(n_+ Z \underline{v}_+ - n_e \underline{v}_e)$. If \underline{j} does not vary with time we have:-

$$(en_e \underline{E}) + (en_e \underline{v} \times \underline{B}) + (\text{grad } p_e) - (\underline{j} \times \underline{B}) - (\underline{P}_{ei}) = 0. \quad \dots \text{Eqn. 23.}$$

where \underline{P}_{ei} represents the rate at which momentum is transferred to ions by collisions with electrons and is in the same direction as \underline{j} : $\underline{v} = (n_+ m_+ \underline{v}_+ + n_e m_e \underline{v}_e)/d$; p_e, p_+ = electron, positive ion partial pressure. (See Spitzer, 1956).

In those situations where an electrical field may exist in a plasma, deviations from electrical neutrality must be considered when using Poisson's law, but may be ignored in these equations. For electrical neutrality, $en_+ Z = en_e$. So $n_e/n_+ = Z$. For an isothermal atmosphere with $T_e = T_+$, $p_e/p_+ = Z$. Using this relation, the two equations may be combined to give:-

$$e\underline{E} = \frac{1}{1+Z} m_+ \text{grad } G + \underline{P}_{ei}/n_e \quad \dots \text{Eqn. 24.}$$

With suitable boundary conditions at the top of the atmosphere, no current can flow vertically. The vertical electrical field cancels a fraction $Z/(1+Z)$ of the gravitational force on the positive ions, and provides a force vertically downwards on each electron just equal to the net downward force on the positive ions. In this way electrical neutrality in the atmosphere is preserved, apart from the minute space charge needed to produce the electrostatic field.

There may be confusion between macro (v) and micro (w_d) velocities. v is the mean velocity of all the particles which are located in a volume element, regardless of where their guiding centres are located.

— 0 —

APPENDIX TO CHAPTER 1

EXTENSIONS TO THE DISCUSSION OF CHARGE MOTION.

Motion of a particle
Electrical Neutrality
Boltzmann equation
Stress tensor
Macroscopic motion
Dynamical equations
Electromagnetic field
Lines of force
Pinch effect
Electromagnetic waves
Hydromagnetic waves
Electrostatic waves
Particle encounters
Non-equilibrium

This appendix, based on Spitzer (1956), contains material which is not used in subsequent chapters. It is included in accordance with a general aim of this work - to provide an introduction for newcomers in this field of research.

APPENDIX TO CHAPTER 1

EXTENSIONS TO THE DISCUSSION OF CHARGE MOTION.

MOTION OF A PARTICLE.

The motion of individual charged particles under given external fields frequently gives some insight into the behaviour of an ionized gas. However, in the presence of a magnetic field the relationship between the current density and the particle velocities is not simple. Moreover, a distribution of particle velocities must be taken into account.

ELECTRICAL NEUTRALITY.

A plasma tends towards electrical neutrality because it cannot normally support an electric potential energy per particle much greater than the mean thermal energy.

KINETIC THEORY OF GASES.

The density of particles in phase space changes with time along a trajectory entirely as a result of collisions among the particles.

STRESS TENSOR.

The particle velocity may be regarded as a random velocity superimposed on a mean velocity. The random velocity gives rise to a scalar pressure. (In the absence of collisions, compression of the gas in one direction may increase the root mean square random velocity in that direction without affecting the corresponding velocities in the other two directions. Thus the pressure has different values in different directions. Shearing stresses arise in a viscous gas, but the viscosity of a fully ionized gas is seldom important).

MACROSCOPIC MOTION.

The macroscopic quantities, current density and mean velocity, are determined by the transfer equations of the kinetic theory of gases.

DYNAMICAL EQUATIONS.

Spitzer (1956) has given two general dynamical equations for macroscopic motion (- his equations 2-11, and 2-12).

The first relates macroscopic acceleration to magnetic induction, pressure, and gravitational potential terms.

The second, a generalized Ohm's Law, relates the time variation of current density to electric field, electromagnetic induction, electron pressure, back e.m.f., and ion to electron momentum transfer terms.

ELECTROMAGNETIC FIELD.

A plasma is a diamagnetic medium. The actual magnetic field inside the gas may differ from the field produced by external currents. Since the permeability is not a very useful concept for plasmas it seems desirable to treat all plasma currents explicitly.

LINES OF FORCE.

Consider the motion of material across the ^{magnetic} lines of force. The lines of force within a perfectly conducting gas tend to be "frozen in" the material. The magnetic flux through any closed contour, each element of which moves with the local mean gas velocity, tends to remain constant.

PINCH EFFECT.

× Consider a cylinder of plasma in which an electric current flows parallel to the cylinder axis. The magnetic pinch effect is explained by assuming that the current is strong enough so that the resultant magnetic field will confine the ionized gas within a finite cross section.

ELECTROMAGNETIC WAVES.

Electromagnetic waves may be described as follows. Suppose \underline{E} is perpendicular to the wave front. Then the electrons in a plasma interfere with these transverse waves, and increase the wave velocity. If the electron density exceeds a critical value, which increases with increasing frequency, electromagnetic waves cannot propagate through the plasma unless a magnetic field is present.

HYDROMAGNETIC WAVES.

These appear only in the presence of a magnetic field, and then only for frequencies small compared with the cyclotron frequency of the positive ions. The positive ions provide the inertia of the oscillation, while the restoring forces are largely magnetic. The oscillations may be regarded as waves in the lines of force, which behave as stretched strings and which are "loaded" with the charged particles.

ELECTROSTATIC WAVES.

If E and j are parallel to the direction of propagation, electrostatic restoring forces are present. These longitudinal waves are called electrostatic waves. In electron oscillations of this type the frequency is so great that the positive ions are unaffected. In positive ion oscillations the frequency is so low that the electrons are distributed at each time in accordance with the equilibrium Boltzmann formula.

PARTICLE ENCOUNTERS.

To analyse non-equilibrium phenomena a quantitative study of collisions is necessary. Electrostatic forces between particles have a much longer range than the forces between neutral atoms. The time interval between "close" collisions gives a mean free path too small by more than an order of magnitude. The "time of relaxation" is a term frequently used to denote the time in which collisions produce a large alteration in some original velocity distribution.

ABSENCE OF EQUILIBRIUM.

The following problems arise in the absence of equilibrium.

- (a) In a gas far from equilibrium, at what rate is equilibrium approached? This applies to a beam of particles passing through a plasma, or to a case in which electron and ion temperatures are gradually approaching each other. (b) Is there a steady non-equilibrium state? This applies

to a flow of current, or to transport of heat across the gas. Hence we must consider transport coefficients (resistivity and thermal conductivity).

CHAPTER 2. CONDUCTING FLUIDS:

	Page No.
INTRODUCTION.	26
1. The Direct Current Characteristic	27
2. The Collision Free Region	27
3. The Townsend Process	28
4. The Breakdown Process	29
5. The Glow Discharge Region	30
6. The Positive Column	31
7. Similar Discharge Tubes	31
8. The Striated Column	32
9. The Arc Discharge	33
10. Breakdown Processes	33
11. Decaying Plasmas	35
12. Some Conclusions	35
13. The Solar Plasma	35

CHAPTER 2. CONDUCTING FLUIDS.

INTRODUCTION.

The purpose of this chapter is to consider different types of electrically conducting fluid, and to suggest contrasts between atmospheric and laboratory systems.

The reason for doing this is that the study of atmospheric systems with rockets is more expensive than laboratory studies so that ideas and equipment for atmospheric work must receive preliminary tests in analogous laboratory systems.

The direct current discharge is considered in greater detail because of its relevance to experimental work.

A discussion of the solar plasma concludes this chapter.

NOTE:-

In general, references have been omitted as the information is duplicated widely throughout the literature. Volumes 21 and 22 of the Handbuch der Physik (1956) contain much useful material on conducting gases.

Figure 3a. Direct Current Characteristic.

To face page 27.

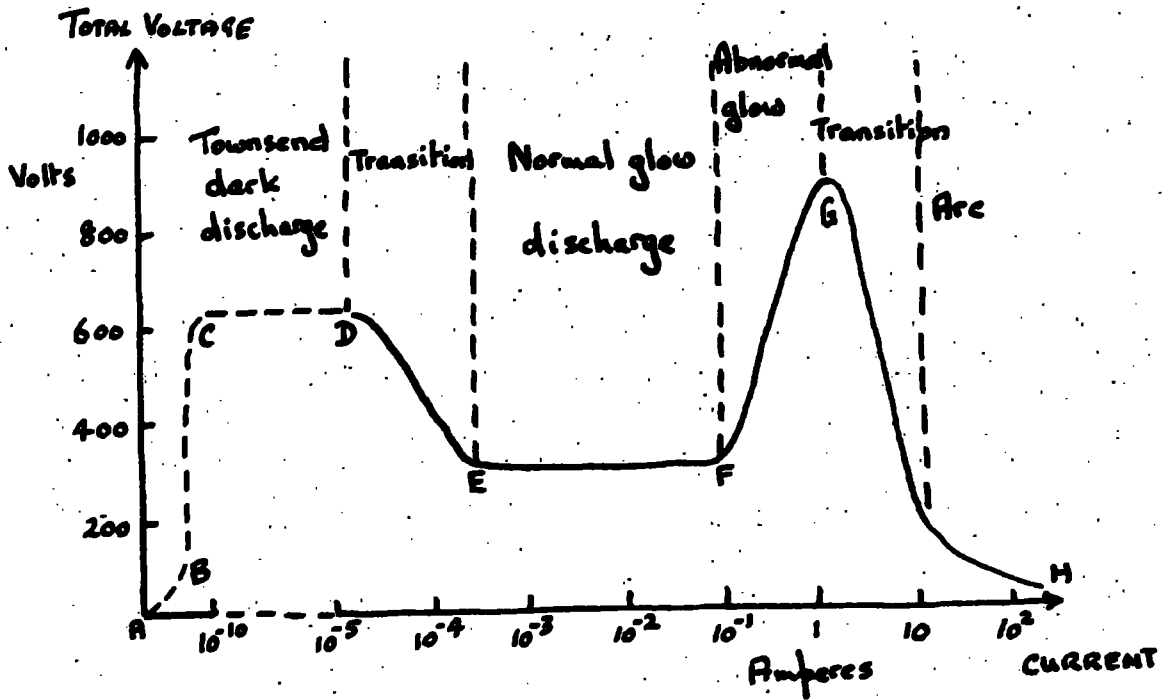
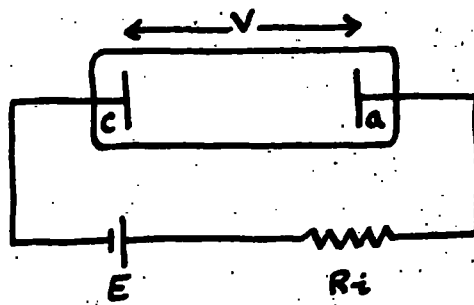

Total Voltage as a function of Current at Atmospheric Pressure. (King, 1961.)

1. THE DIRECT CURRENT CHARACTERISTIC.

The resistance of a gas at low pressure is non-linear. Using a circuit of the type shown in figure 3a, the current (i) and potential drop (V) in the gas ^{between} the electrodes a (anode) and c (cathode), are governed by the following relations:-

$$E = Ri + V$$

$$V = F(i)$$

The form of the function $F(i)$, i.e. the direct current discharge characteristic, is shown in figure 3a. It turns out, however, that this curve is mainly governed by electrode phenomena, in particular by the behaviour of the cathode potential fall and tells us little about the voltage gradient at the column of the discharge. The voltage gradient increases towards both electrodes. This follows from a general pattern of behaviour, namely that as the losses increase, the voltage gradient must increase together with an increase in actual temperature and a reduction in the discharge diameter. The presence of the electrodes represent^{ing} boundary surfaces at high thermal conductivity at temperatures well below those associated with the discharge column and the gas immediately surrounding it causes increased thermal gradient through the gas, and hence an increase in voltage gradient. This occurs quite independently of the electrode mechanism proper. (See paragraph 9).

2. THE COLLISION FREE REGION.

The portion AC of the characteristic (figure 3a) represents a region in which collisions do not take place. It is sometimes stated that in the region AB, ionisation is caused by cosmic rays. Actually, though it does not matter much in this context, the ionisation near the ground is only about 20% due to cosmic rays, the rest being due to radio-activity, (and the proportion is increasing with fall-out). The ions formed in the discharge tube recombine before they can reach the

electrodes. The situation is similar to that obtaining in the lower atmosphere where the thunderstorm process acts as the electric direct current generator for a world-wide direct current discharge system. Ohm's law is valid for this region, the specific conductivity being given by:-

$$\sigma(n_+ v_+ u_+ + n_- v_- u_-)$$

where v is the valency and u the mobility. (An analogy is to be noted between this and conduction in electrolytes suggestive of the use of the Debye length concept in discharge contexts - see chapter 1).

In the region BC the ions are carried to the electrodes but the electric field which collects them is not strong enough to cause collision ionisation. ^{The} Voltage reached at C depends on the mean free path and hence on the electrode separation (d) and gas pressure (p), as well as on electrode phenomena. At this voltage ionisation is produced by electrons colliding with molecules.

3. THE TOWNSEND PROCESS.

Consider the region CD (figure 3a). As a result of ionisation ^{Sing} radiation, suppose that n_0 electrons leave the cathode per second and n is the number of electrons at a distance x from the cathode, where the n 's have the dimensions per unit volume per second. Collision ionisation between electrons and molecules in the element dx produces extra electrons and the process is described as an electron avalanche. The number of electrons is given by:-

$$dn = a n dx$$

where a is a proportionality constant.

Hence: $n = n_0 \exp(a x)$ Equn. 25.

If n is now the number of electrons at the anode, then the anode current I_a depends on

Figure 4. Spark Breakdown Voltage.

To face page 29.

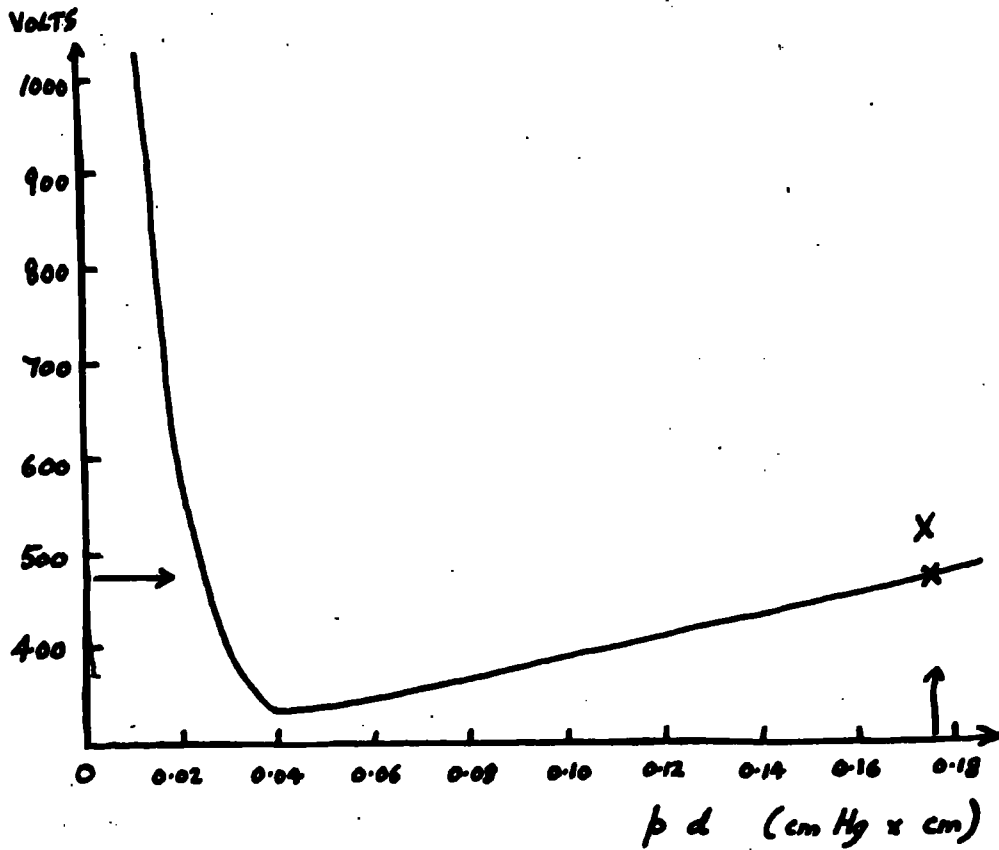

Spark-breakdown voltage for plane-parallel electrodes in air at a temperature of 20°C (Cobine, 1941).

X is the experimental operating point discussed on page 105.

$$n_e = n_0 e \exp(ad) = I_0 \exp(ad)$$

where I_0 is the electron current from the cathode, or, in other words, the anode current in low fields.

Other ionising processes in the gas are possible, such as collisions between ions and molecules, thermal ionisation by neutral molecules, and photoionisation.

Secondary processes cause the emission of more electrons, so let n'_0 electrons actually leave the cathode. Thus the number of electrons produced by collision ionisation is:-

$$n'_0(\exp(ad) - 1) = n_+$$

- and this is equal to the number of positive ions (n_+) produced. Since secondary processes depend on positive ions striking the cathode, the number of secondary electrons leaving the cathode is given by:-

$$(n'_0 - n_0) = \gamma n'_0 (\exp(ad) - 1)$$

where γ is a proportionality constant.

$$I_a = n'_0 e \exp(ad) = \frac{I_0 \exp(ad)}{1 - \gamma(\exp(ad) - 1)} \neq \frac{I_0 \exp(ad)}{1 - \gamma \exp(ad)}$$

Excited molecules (metastables) also can cause electron emission by colliding with the cathode themselves, or by emitting photons which strike the cathode.

4. THE BREAKDOWN VOLTAGE.

The sparking or breakdown potential drop (V_g) corresponds to:

$$\exp(ad) = (\gamma + 1) / \gamma$$

This implies that I_a tends to infinity in other words, I_a is greater than 0 even if I_0 is ~~usual~~ zero.

Paschen found by experiment that $V_g = f(pd)$. The relation is shown in figure 4.

For small values of (pd) the breakdown voltage is high because the mean free path is so great that there are few collisions, while for high values of (pd) the breakdown voltage is high because the mean free path is so small that few electrons gain sufficient energy from the field between collisions to cause ionisation. At high pressures positive ions do not have time to reach the cathode during the spark. At pressures of the order of 100 atmospheres with centimetre gaps, Paschen's law breaks down as high fields at the cathode cause "Field emission" and this is independent of ionisation in the gas.

5. THE GLOW DISCHARGE REGION.

The processes taking place in the region EF of the characteristic shown in figure 3a have been described as follows. (Handbuch der Physik). The phenomena taking place nearest to the cathode are related to the liberation of the electrons necessary for the discharge. Once the discharge is established the positive column acts as a conducting path shorting out a part of the gap between the electrodes. The length of the column adjusts itself until the minimum breakdown voltage occurs. If the anode is moved further away from the cathode a slightly larger voltage is needed to maintain the discharge and the positive column extends to occupy the additional length.

The formation of spots on the anode is connected with the fact that the necessary current is conveyed to the anode by the least applied potential. These spots are regions of intense ionisation.

It has been found that a glow discharge may be set up in a moving gas. The working voltage decreases when the gas flows towards the anode and increases slightly when the gas flows towards the cathode.

As the pressure increases, the positive column extends, and at a certain pressure it contracts radially. At low pressures, the positive column is driven into the anode.

Figure 5. Glow Discharge Parameters. To face page 31.

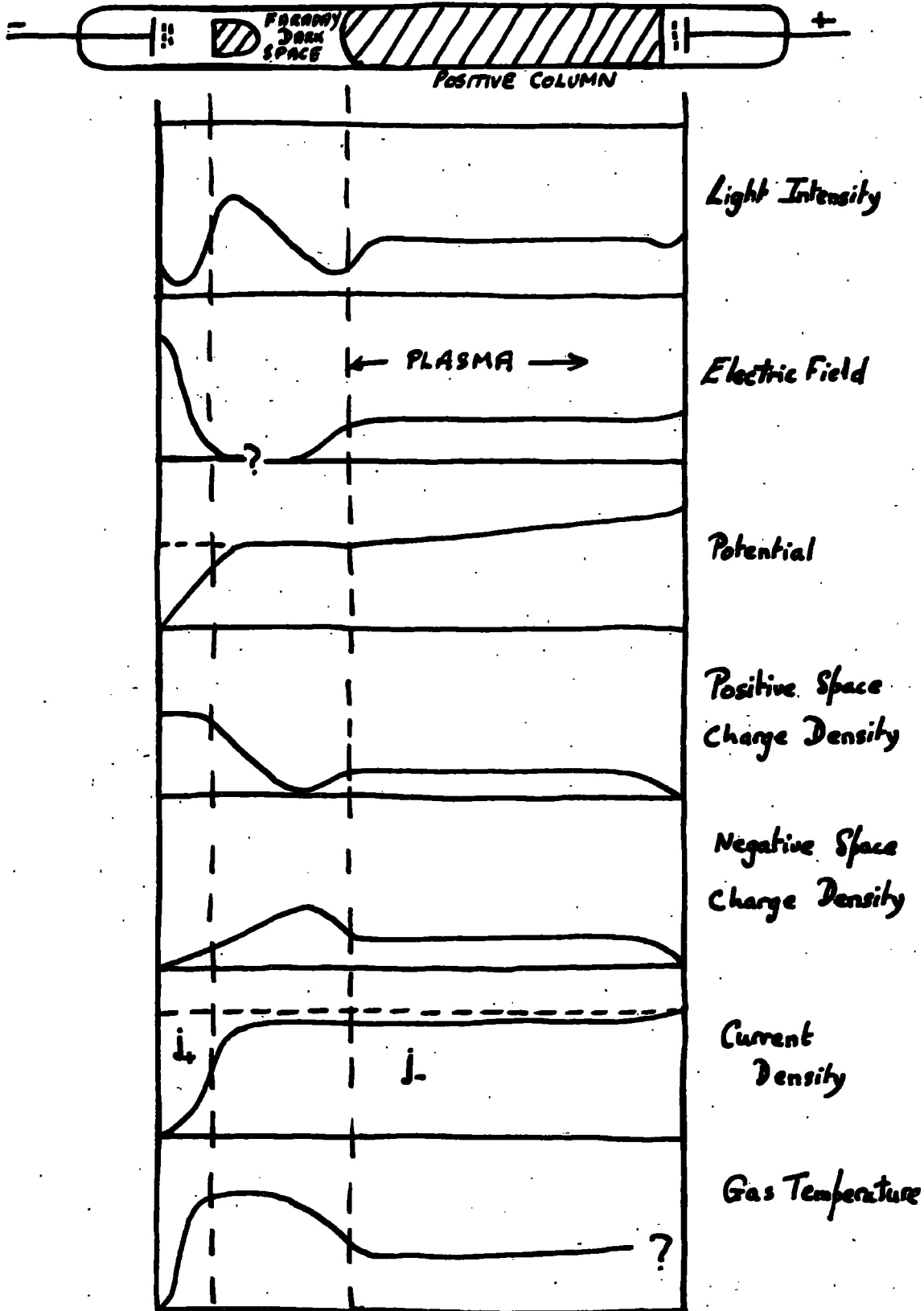

In a new tube, the walls are covered with a surface layer of gas which is slowly removed by bombardment with ions. Capricious starting effects may be the outcome of patches of charge on the walls remaining from a previous discharge. These can be removed by running the hand over the outside of the tube. The walls may also become coated with cathode material-sputtering - but this ^{effect} is slight with tungsten.

6. THE POSITIVE COLUMN.

The glow discharge parameters are shown in figure 5. Except at the ends conditions are usually uniform along the length of the column. The weak field sustains a small rate of ionisation due to random electron motion. Ion and electron concentrations (usually between 10^{10} and $10^{13}/\text{cc}$) are equal. It is often assumed that the electron energy distribution is Maxwellian, and that the electron temperature is constant across the discharge. Charges flow radially by an ambipolar process to the walls, where they recombine at the same rate as they are produced.

The current along the axis of the column is sustained by electrons which flow in from the Faraday Dark Space, travel along with a small drift velocity superimposed on their random motion, and are collected at the anode. The attraction of electrons and repulsion of positive ions by the anode results in a negative space charge and an enhancement of the field. In this short region additional ionisation occurs so that ions are fed into the positive column and balance those that flow out into the Faraday Dark Space.

7. SIMILAR DISCHARGE TUBES.

In the conclusions to this chapter the importance will be stressed of considering "proper variables" rather than specific parameters. Accordingly, the relations between similar discharge tubes will now be described. It should be understood that these relations are only strictly valid over small ranges of the parameters to which they refer and that they are given here only in order to illustrate general principles. If the same voltage is maintained across similar discharge

tubes, the following relations hold:

	Tube 1	=	Tube 2
Discharge current	i_1	=	i_2
Discharge voltage	V_1	=	V_2
Temperature	T_1	=	T_2
Electrode Separation	d_1	=	$d_2 \times a$
Electrode radius	r_1	=	$r_2 \times a$
Tube radius	R_1	=	$R_2 \times a$
Mean free path	λ_1	=	$\lambda_2 \times a$
Pressure	p_1	=	p_2 / a
Longitudinal field	X_1	=	X_2 / a
Gas density	n_1	=	n_2 / a
Surface Charge density	s_1	=	s_2 / a
Volume Charge density	S_1	=	S_2 / a^2

From these relations, the following "proper variables" emerge:-
 $X\lambda$, X/p , pd , pR . In this particular case "proper variables" may be defined as quantities which do not depend on a , and if results are expressed in terms of them they will be true whatever the value of a happens to be.

8. THE STRIATED COLUMN.

Individual striations are curved convex towards the cathode. This is the effect of the negative wall charge. The electric field is weakly negative between the striations, zero at their edges, and may be as high as 60 v/cm in the middle of a striation. As far as stationary striations are concerned, the regions in which various kinds are formed can be mapped as closed areas on the (pR) against (i) curve. For high values of (pR) there are no striations, and in general they disappear when the current density is greater than 10 mA/cm^2 . Moving striations disappear when the current density is greater than 1 A/cm^2 , or when (ip) is high.

Figure 3b Voltage Gradient Characteristic.

To face page 33.

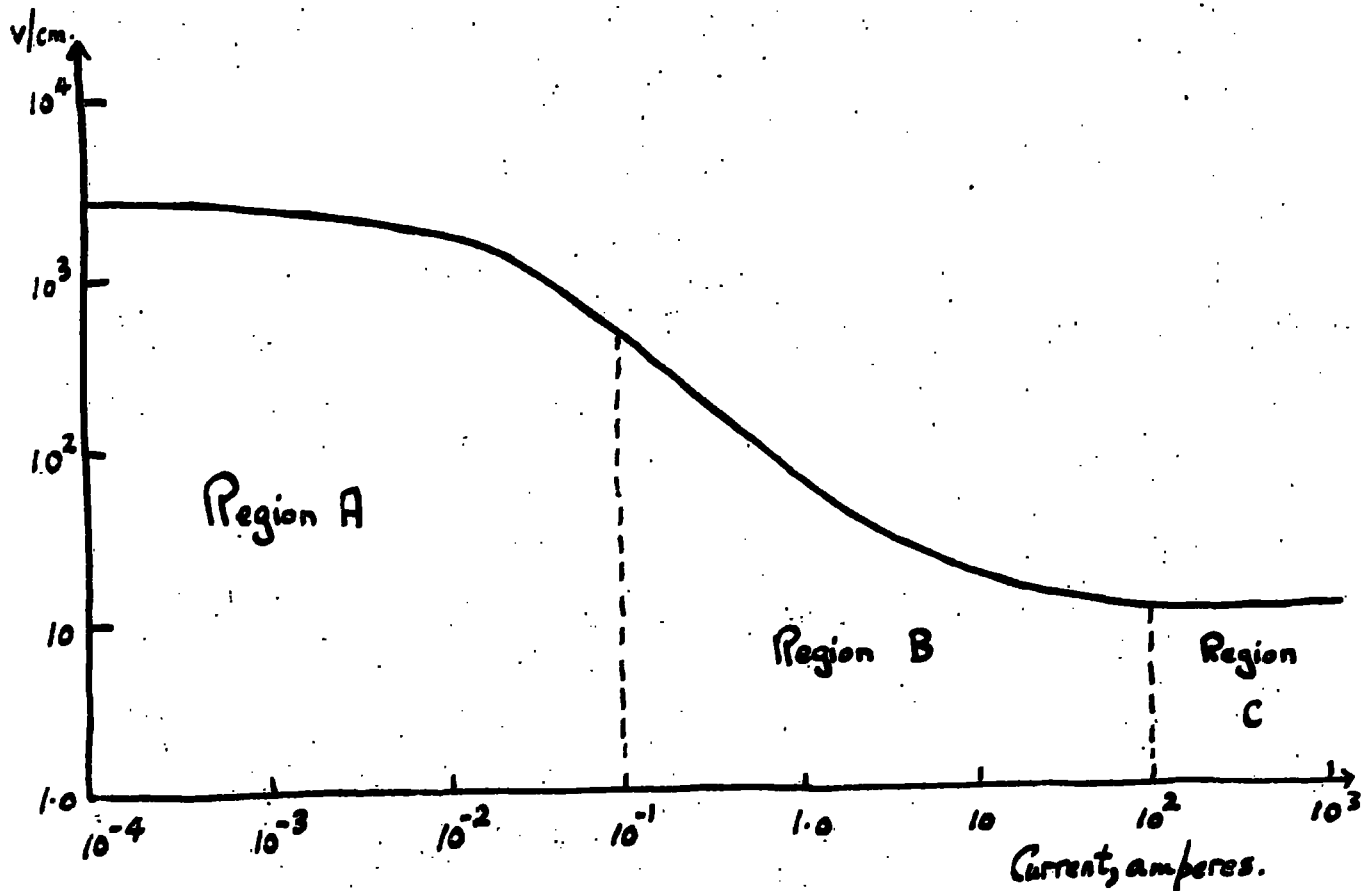

Voltage gradient-current characteristic for an arc in air at atmospheric pressure. (King, 1961)

9. THE ARC DISCHARGE.

In this work the arc column is defined as a column of gas in which thermal equilibrium exists between the electron, ion and gas particles. The electrical conductivity of this column is maintained by thermal ionisation. The glow column is defined as a column of gas in which thermal equilibrium does not exist, (i.e. the electrons, ions and gas particles each have different temperatures), the electrical conductivity being maintained by field ionisation. This follows the convention used by King (1961). "Glow" and "Arc" cathodes are markedly different and the transition from one to the other takes place extremely suddenly. The mechanisms are completely different and the voltages associated with the two types are also markedly different - 200 to 500 volts in one case and about 10 volts in the other. The cathode voltage fall can be used to classify these two types unambiguously. The free column voltage gradients over a very wide range of current are shown graphically in figure 3b. This curve is an indication of the voltage gradient of a reasonably uniform discharge column, as free as possible from electrode vapour and reasonably remote from electrode phenomena of the type described at the end of paragraph 1 (Direct Current Characteristic) of this chapter. At very low currents the voltage gradient departs from the normal negative characteristic of an arc, the discharge column gradually changing from a glow column at currents of the order of milliamperes to an arc column which is well established at a current of 0.1 amperes. At currents from 0.1 to 100 amperes the voltage gradient has the normal negative arc characteristic. At currents above 100 amperes the voltage gradient of an arc remote from electrodes remains almost constant at 10 V/cm at least up to currents of 10,000 amperes.

10. BREAKDOWN PROCESSES.

Most breakdown processes in gases are initiated by an electron avalanche, the term applied to the process of electron multiplication in an electric field. Breakdown requires, in addition to the initial avalanche, secondary ionising processes which lead to secondary avalanches.

In the Townsend theory of breakdown, which has already been described in this chapter, for each electron created in the primary avalanche a certain number of secondary electrons, available for initiating secondary avalanches, are produced. The Streamer theory of breakdown has been proposed as an alternative. In this the initial process is again the electron avalanche which grows until it produces an increase of field at the head due to the positive space charge; secondary avalanches originating in electrons caused by photoionisation in the gas are directed into the positive space charge region. In this way the region of high positive space charge is rapidly extended towards the electrodes and is also quite permeated with electrons or negative ions. This channel of positive and negative ionisation constitutes the so-called Streamer and when this growth is extended to the two electrodes the gas path is effectively short circuited and breakdown is effected.

By using a high frequency electric generator instead of a direct current source, the breakdown voltage is lowered. This is due to incomplete removal of positive ions during a half cycle. Positive ions do not quite move across the inter-electrode space. Positive space charge is built up giving rise to distortion of the field and enhanced values of α (see equn. 25.). The electrons move rapidly across the gap and a trail of positive ions is left behind. The exponential form of the ion density (see equn. 25.) means that the ions are concentrated near an electrode, and are therefore more like a layer than a column. During a cycle, the space charge layer makes an excursion into the gap and back towards the electrode. The gradual growth of space charge is responsible for an increase in ionisation as compared to direct current values, and hence breakdown at lower potentials.

At ultra high frequencies there is a large fractional change in the breakdown voltage. The true nature of breakdown at ultra high frequencies (10 Mc/sec) is that the electron orbit is just filling the gap.

11. DECAYING PLASMAS.

If the generator is removed from a laboratory plasma, the plasma quickly decays. There is thermal equilibrium between ions and electrons in this decaying plasma, though this is obtained at the expense of temporal equilibrium and the fact that measurements must be made in an extremely short space of time. This system is of interest however as thermal equilibrium is thought to exist in the ionosphere, at least in the lower regions. (See chapter 6).

12. SOME CONCLUSIONS.

The problem of simulating the ionosphere in the laboratory is not simply a matter of having a plasma at the correct pressure. Of more importance are such matters as the relations between the dimensions of the apparatus and the Debye length and mean free path; and also the extent to which the physical processes in the laboratory system resemble those in the ionosphere. The experiments described later on in Section II were carried out in a laboratory system which was neither easy to handle experimentally, nor exactly resembled ionospheric conditions owing to the absence of thermal equilibrium in the experimental discharge. Successful experiments have been carried out in this country and abroad using such systems as decaying plasmas and high velocity plasma streams. (See chapter 6). If these matters are borne in mind, the pressure can be taken into consideration as well by dimensional analysis (see Similar Discharges) as by vacuum technique.

13. THE SOLAR PLASMA.

Distances from the earth and sun are conveniently given in terms of their radii, R_e (about 4000 miles) and R_s (about 400,000 miles). The atmosphere of the sun is a plasma which extends further into interstellar space than $200 R_s$, which is the distance between sun and earth. Near the solar corona this plasma is at a temperature of 10^{60} K and this falls gradually to 10^5 K at $200 R_s$, and then very rapidly because the ions recombine in interstellar space. The electron

concentration falls by a factor of 10^4 in the distance $200 R_E$ between the vicinity of the corona and the position of the earth. The plasma above the ionosphere of the earth merges smoothly with the solar plasma. The moon, at a distance of $60 R_E$ from the earth encounters a plasma of temperature 10^5 °K, and its situation is in some ways like a spherical probe in a gas discharge.

The picture of the hot solar gas steadily conducting a weak stream of energy into the earth's atmosphere is dramatically changed by the frequent storms on the sun. At these times clouds of ionized particles are blown out from the sun, and, these extend the magnetic lines of force of a sunspot magnetic field to the vicinity of the earth. The temporary linkages enable the particles to spiral directly from sun to earth. Only the more energetic particles will penetrate to atmospheric levels, the majority being trapped in the van Allen region. These charged particles spiral along the terrestrial lines of force and are reflected in the converging polar fields. This is the cause of the van Allen radiation belts of high speed particles trapped within the earth's magnetic field. Contours which show the counting rates per second of the Geiger-Muller tubes in the satellite 1958e and in lunar probe Pioneer III have been given by Van Allen (1959). (See chapter 4, paragraph 26: Rotation of Earth).

A STUDY OF METHODS OF MEASUREMENT OF THE ELECTRIC CHARGE ON A ROCKET
AND OF AMBIENT ELECTRIC FIELDS USING PROBE TECHNIQUES.

SECTION 1. SURVEY OF LITERATURE.

CHAPTER 3. UPPER ATMOSPHERE.

	Page No.
INTRODUCTION.	38
1. MODEL OF THE ATMOSPHERE.	38
2. EXISTENCE OF THE IONOSPHERE.	40
a. History of the Concept of the Ionosphere	40
b. Electron Profiles - Production and Loss of electrons	41
c. Electron Profiles - Diffusion of Electrons	44
d. Wave Propagation through the Ionosphere.	45

Figure 6.

To face page 38.

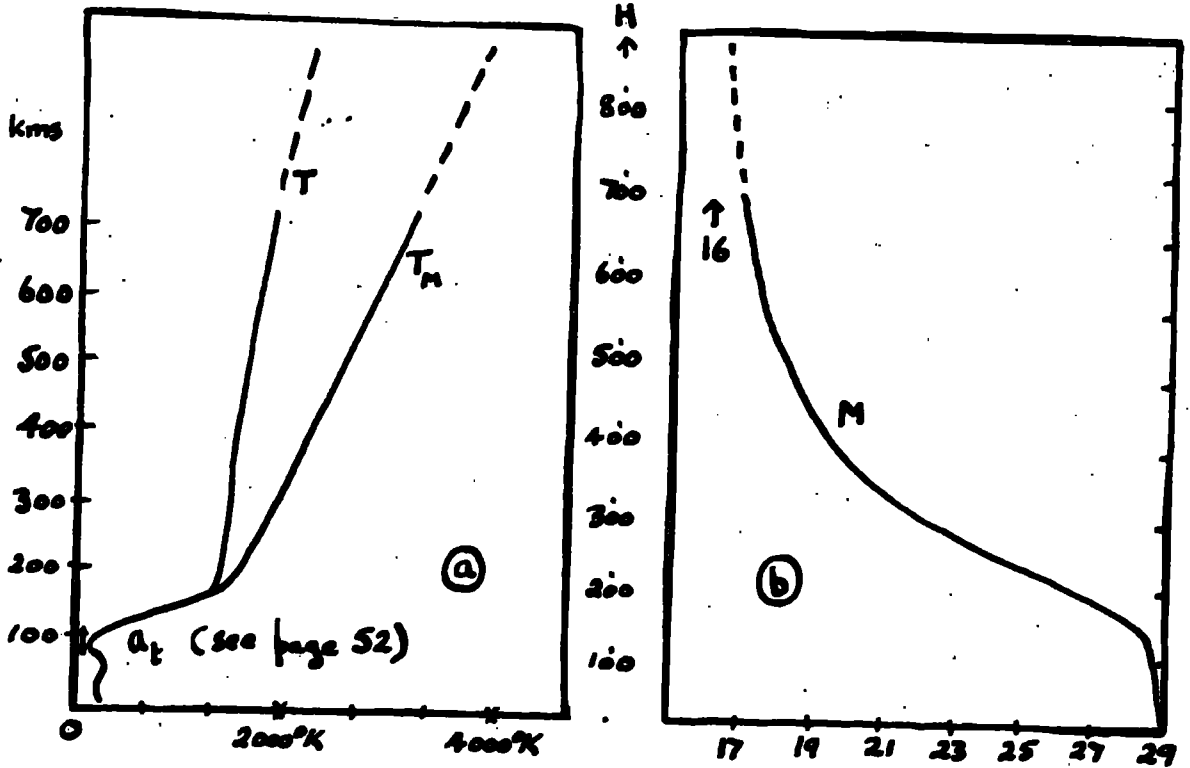
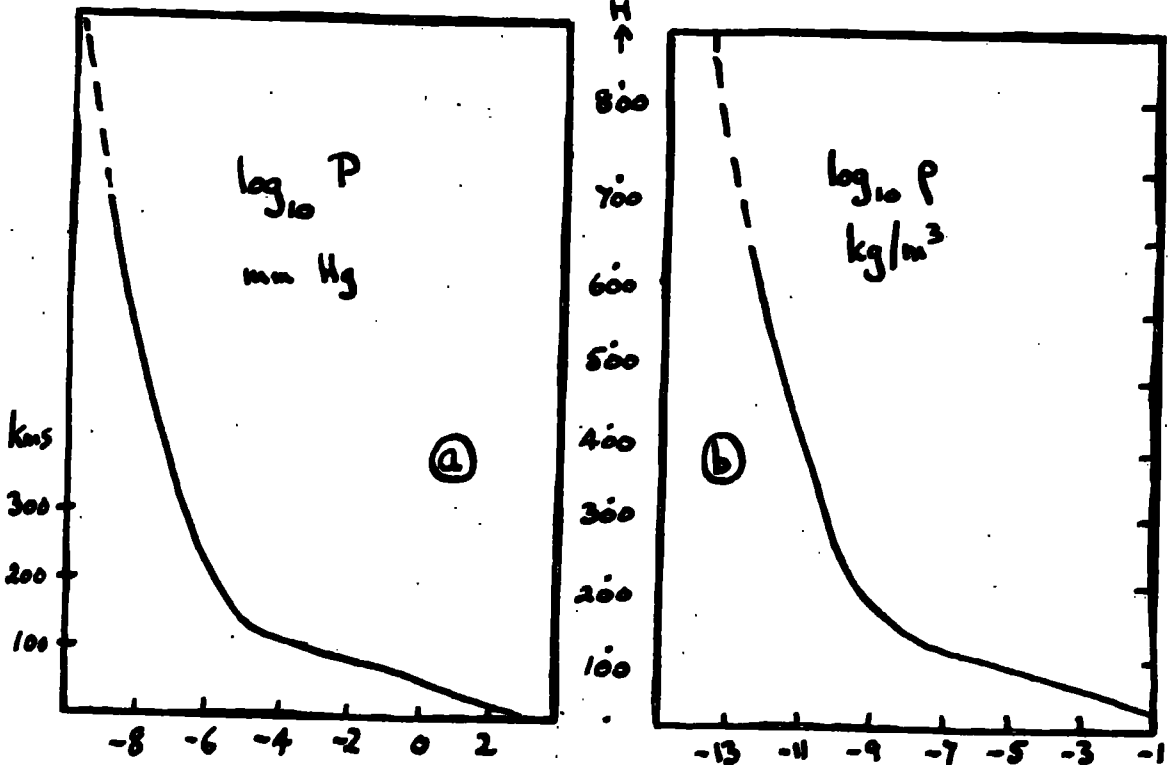

Figure 7.

Upper Atmosphere Parameters.



CHAPTER 3. UPPER ATMOSPHERE.

INTRODUCTION.

In describing the upper atmosphere it is sufficient for present purposes to consider the variation with height of mechanical and electrical properties. Accordingly, we shall first describe the A.R.D.C. model atmosphere (Minzner et al, 1959), and then discuss the existence of the ionosphere. In the latter case we are only interested in the measurement and explanation of the electron profiles (Ratcliffe, 1959, 1960a, 1960c). The scale height and penetration frequency are derived here but not in the references cited.

1. MODEL OF THE ATMOSPHERE.

In considering the upper atmosphere (Minzner et al, 1959), it is sometimes more convenient to discuss geopotential rather than geometric altitude. The geopotential (H) at an altitude (Z) is the potential energy of a unit mass at that altitude relative to the potential energy of that same unit mass at sea level. For $g = 9.81 \text{ m/sec}^2$ (acceleration due to gravity) an interval of one standard geopotential metre corresponds to a distance of 1 metre.

The properties of the upper atmosphere are summarized by the profiles in figures 6 to 11 (Minzner et al, 1959).

Notes on the Profiles:-

Figure 6:-

- a) Kinetic Temperature and Molecular-Scale Temperature.
- b) Mean Molecular Weight.

The relationship between temperature (T) and molecular-scale temperature (T_m) is given by:-

$$MT_m = TM_0$$

where M is the molecular weight and M_0 the sea level molecular weight. The shape of this curve is considered in the discussion of the resonance theory (in chapter 4). Molecular weights are referred to oxygen = 16.

Figure 8. To face page 39.

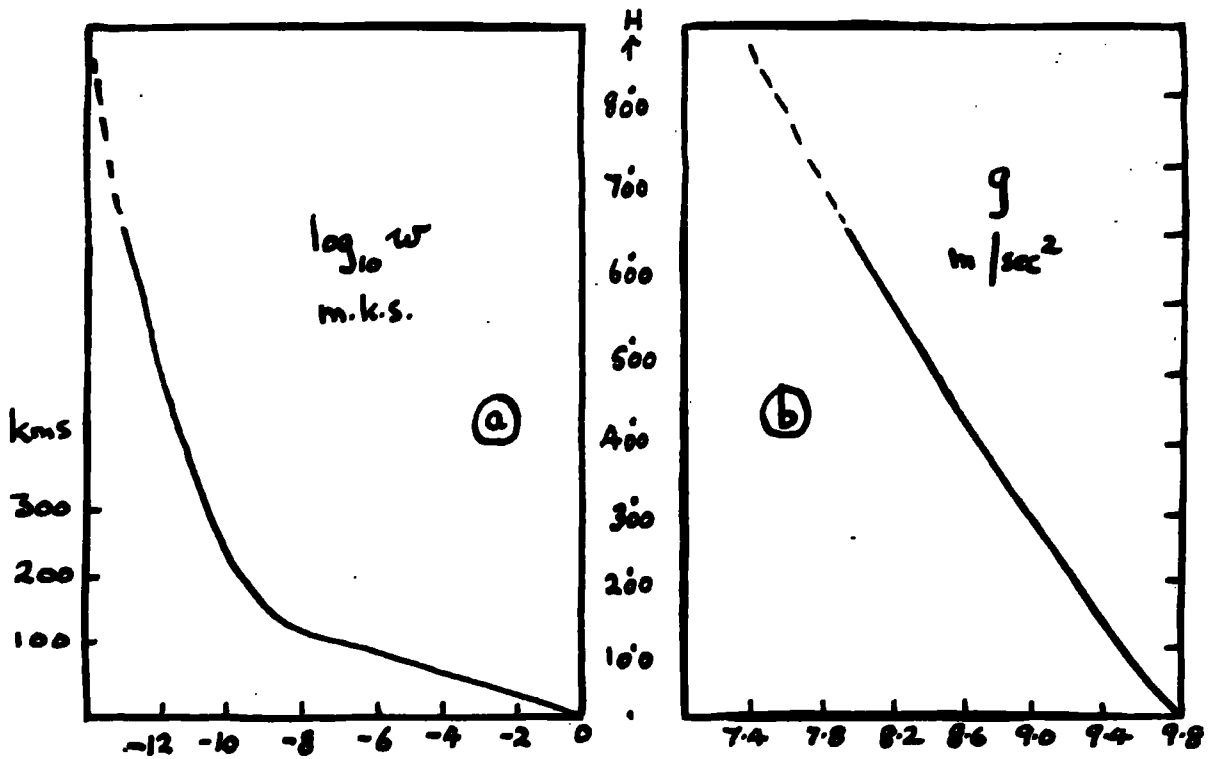

Figure 9. Upper Atmosphere Parameters.

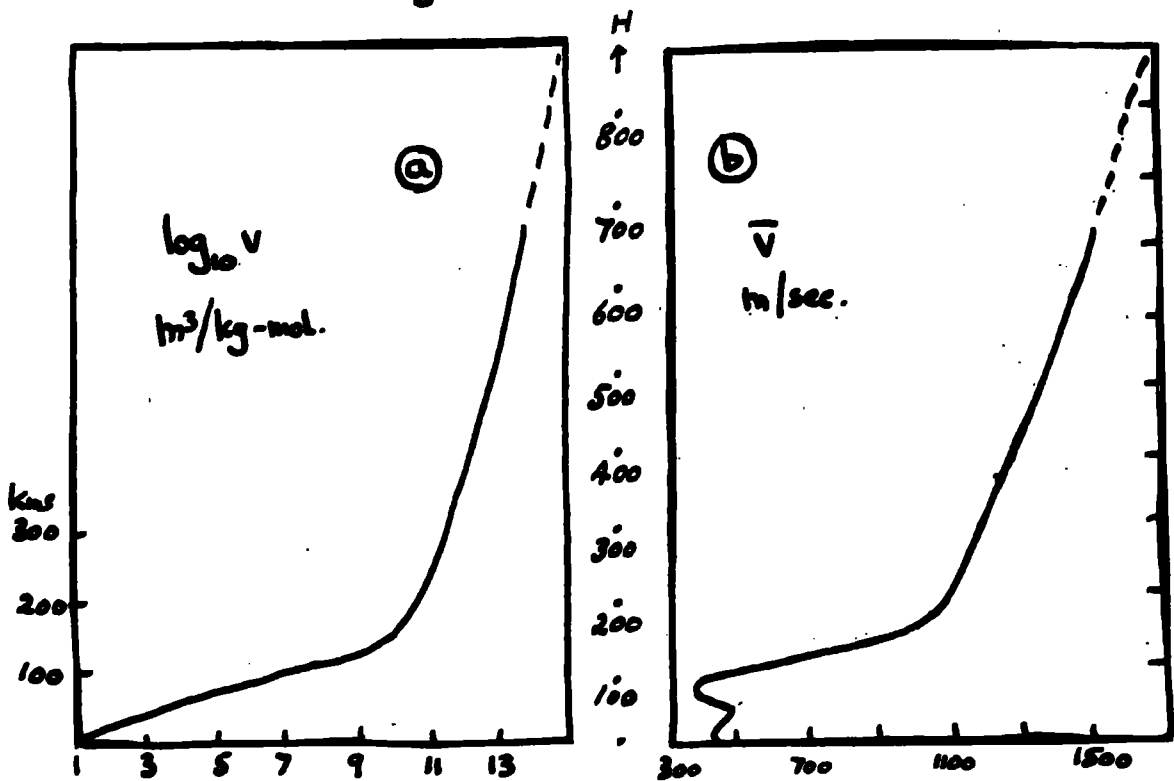

Figure 7:-

- a) Pressure.
- b) Mass Density.

Mass density is given by the formula $\rho = P/RT_m$ where $R = 8.3 \times 10^3$ in MKS units.

Figure 8:-

- a) Specific weight.
- b) Acceleration of gravity.

The specific weight is given by $\gamma = g \rho = g P/RT_m$.

Figure 9:-

- a) Mole volume.
- b) Mean Particle Speed.

The mole volume (v) is the specific volume of the gas (the reciprocal of the density) when the density is expressed in terms of the mole mass unit. The mole is defined as 1 kg-mol = M gm.

The mean particle speed is given by $(8R/nN_0 \times T_m)^{1/2}$.

Figure 10:-

- a) Scale height.
- b) Number density.

The scale height H_s is the space constant for pressure variation with height. For an isothermal atmosphere:-

$$\frac{dp}{dz} = -Dg \text{ where } D \text{ is the density.}$$

$$p = nkT \quad D = mn$$

$$p = p_0 \exp(-z Mg/RT) = p_0 \exp(-z/H_s)$$

where M is the molecular weight.

$$H_s = RT/Mg$$

..... Equn. 26.

Figure 10. To face page 40.

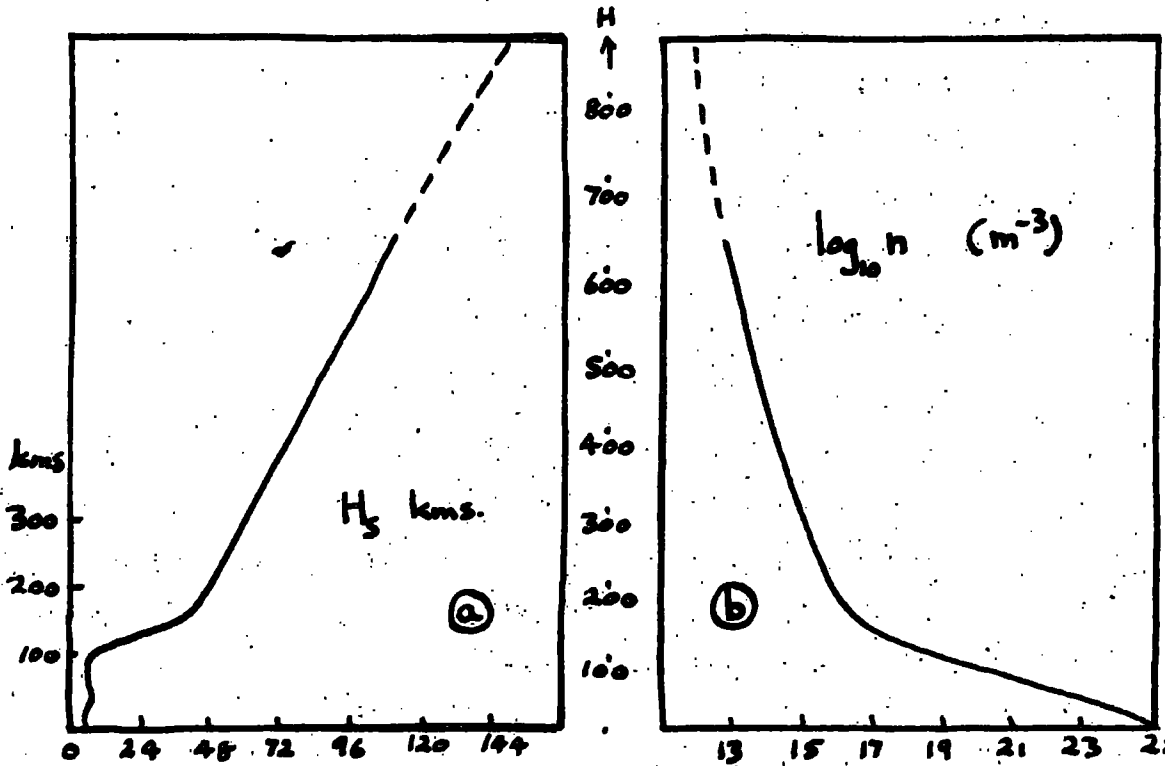

Figure 11. Upper Atmosphere Parameters.

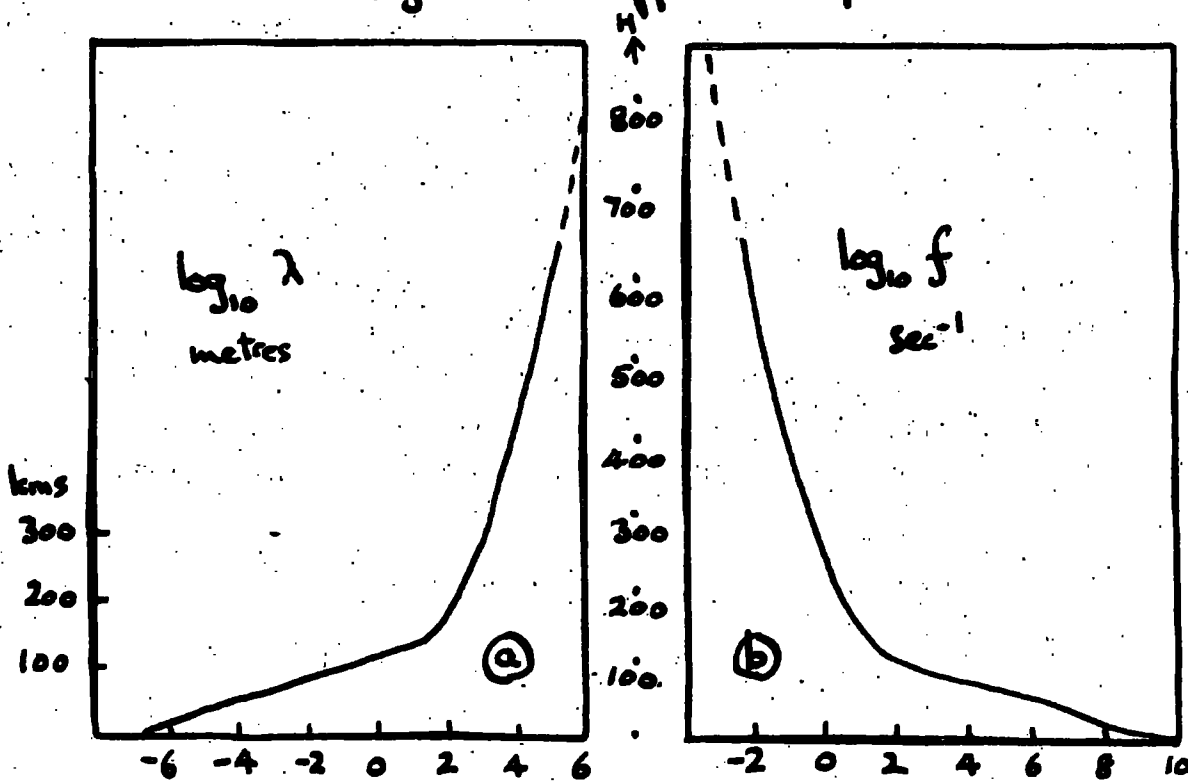

Figure 11:-

- a) Mean free path.
- b) Collision frequency.

The mean free path is given by $\lambda = 1/(2^{1/2} n s^2 n)$ where the molecular diameter $s = 3.65 \times 10^{-10}$ m. The collision frequency is $4s^2 n \left\{ \frac{n}{2} \left(\frac{R}{M} \right) \right\}^{1/2}$.

2. THE EXISTENCE OF THE IONOSPHERE.

a. HISTORY OF THE CONCEPT OF THE IONOSPHERE.

A century ago Kelvin argued that since air at a low pressure is conducting, there must be a conducting layer high up in the atmosphere.

In 1882 Balfour Stewart, thinking about terrestrial magnetism, postulated that there are electric currents in the upper atmosphere. (See chapter 4, paragraph 2e; Magnetic Variations). In 1900 Marconi was able to send radio waves across the Atlantic, but these waves did not travel in a straight line. Diffraction effects could not account for the intensity of the received signal.

Kennelly and Heaviside, in 1902, working independently, attributed the results of Marconi's experiments to a conducting layer about 100 km above the ground. The basic theory of the ionosphere was adapted from existing theories of the conductivity of ionized gases by Eccles (1912).

Appleton and Barnett in 1925, working at Cambridge and using existing BBC transmitters and later on some aeriols of their own, studied the separate existence of a wave reflected from the sky and one transmitted along the ground by analysing the interference patterns caused by the difference in phase between them. Breit and Tuve studied the ionosphere by using pulses of radio waves - in other words an early radar technique.

Modern research on the ionosphere uses both radio and rocket techniques.

Figure 12. Electron Production and Loss.

To face page 41.

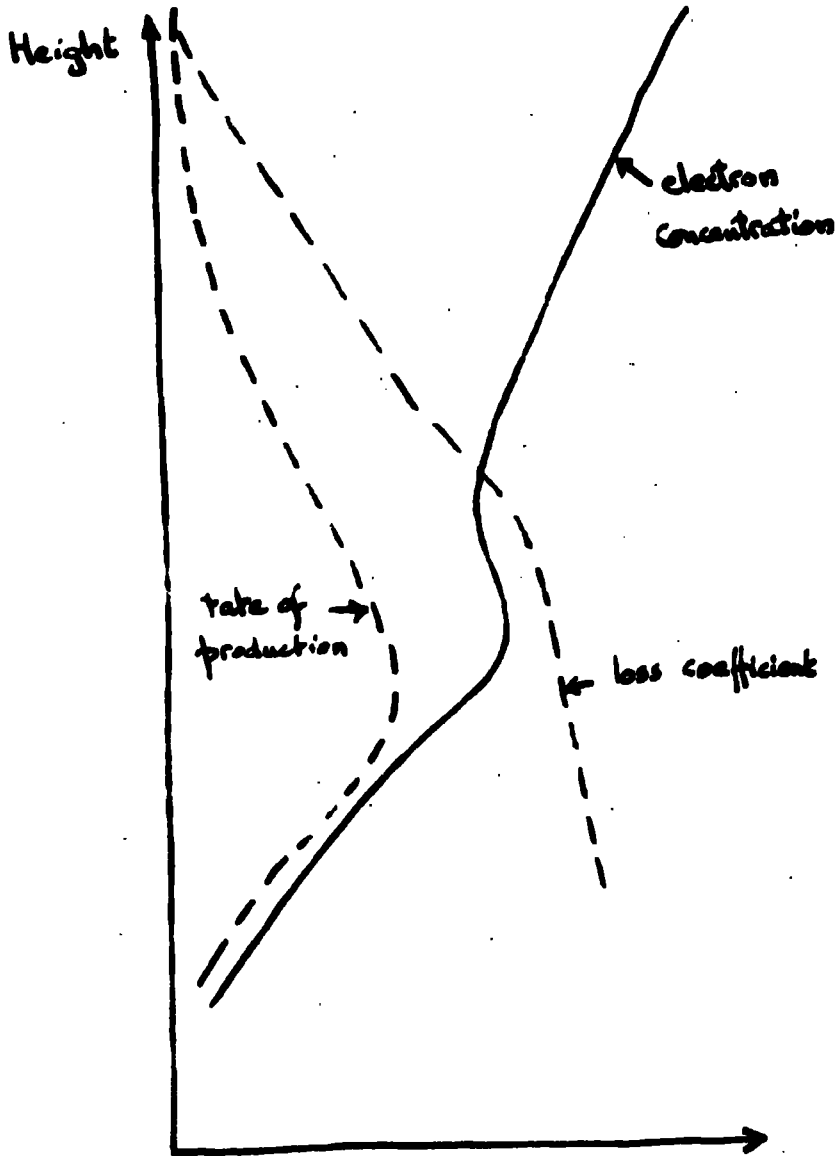

Sketch to illustrate the production and loss of electrons (Ratcliffe, 1959).

b. ELECTRON PROFILES - PRODUCTION AND LOSS OF ELECTRONS.

In considering the theory of the origin and shape of the electron concentration profile in the atmosphere it is necessary to discuss both the production and the loss of electrons (see figure 12). If the production of electrons were due to photoionization by radiation from the sun it would be expected that the electron concentration would be greater lower down because increasing density means that there are more particles to ionize. On the other hand the increasing absorption of the radiation with increasing density would oppose this.

Thus simple considerations predict an ionized layer with a peak rate of production, within some range of height.

For a model of the ionosphere which contains only one gas at a uniform temperature and for which the absorption is not a function of the wavelength, the following conclusions have been deduced. The height of the peak of electron production (h_m) is determined by the absorption coefficient, the scale height, the gas density and the angle at which the radiation is incident. The magnitude of the electron production rate at the peak value depends on the radiation intensity, the scale height and the angle of incidence.

Consider the production of electrons. Let the rate of ionization be such that q_e electrons are formed per second per unit volume. The presence of negative ions may be allowed for by defining an effective value for q_e such that

$$q = \frac{q_e n_e}{n_e + n_-}$$

Those electrons which are not lost from a region by diffusion into another region must be lost by processes of recombination or attachment.

The latter process means that electrons are lost by the formation of negative ions, at a rate per unit volume per unit time given by:-

$$-bn_e N \doteq -Bn_e$$

where B is the attachment coefficient.

Attachment is possible to atomic and molecular oxygen, but not to atomic and molecular nitrogen. It should be noted that collision or photo detachment is also possible.

Electrons may be lost by recombining with positive ions; the rate of loss of electrons by this process being:-

$$-a_e n_e n_+ \doteq -a_e n_e^2 \text{ p.u.v./sec.}$$

where a is the recombination coefficient.

The negative ions may be thought to modify the recombination coefficient, so that:-

$$a = a_e + a_i n_- / n_e$$

where a_i is the recombination coefficient for positive and negative ions (n_+ , n_-).

Suppose that electrons are produced by the photoionization of atomic oxygen, and lost by a complex recombination process involving charge exchange and dissociation, so that the following equations hold:

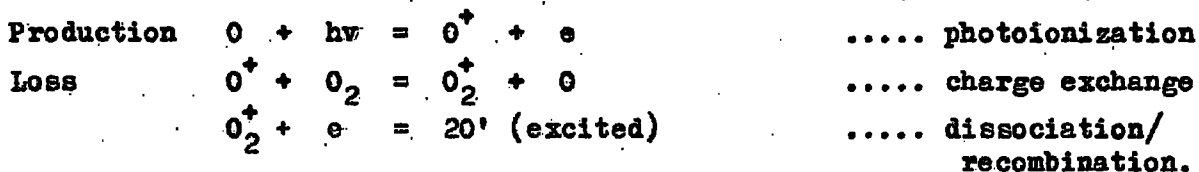

Let L be the rate of loss of electrons per unit volume per second,

N be the concentration of oxygen molecules

K_b be the combination coefficient for O_+ .

K_c be the combination coefficient for electrons.

Then it can be shown that if

$K_b N$ is much greater than $K_c n_e$, then $L = K_b n_e^2$
i.e. recombination.

And if $K_b N$ is much less than $K_c n_e$, $L = K_c N n_e$

i.e. attachment.

The first condition holds below 200 km where the number of oxygen molecules is high; the second holds at heights greater than 200 km where there are few oxygen molecules. It has been confirmed by Dickinson and Sayers (1960) that dissociative recombination with molecular oxygen ions produced by a charge exchange reaction could be the primary electron loss process in the F2 layer.

If the electron concentration does not vary with time, then the following equation, representing quasi-equilibrium, is true:-

$$\frac{dn_e}{dt} = q - L = 0$$

where q represents the effective production of electrons and $L = \frac{Bn_e}{\tau_e} + a n_e^2$.

This condition obtains at midday and early morning. It can be shown that for a layer in equilibrium, if a or B decrease with increasing height, the peak of the electron concentration will be at a greater height than the peak of the electron production rate. If the electron concentration does vary with time, then:-

$$\frac{dn_e}{dt} = q - L \neq 0$$

Suppose that a change in the electron density takes place corresponding to a change in the electron production rate, as for instance at the time of a sudden ionospheric disturbance. Then it can be shown that the excess electron density follows a small perturbation in the production rate like a system with a time constant $1/(2an_e)$. This is also the time between q and n_e reaching their respective maxima.

c. DIFFUSION OF ELECTRONS.

(Sec. chapter 1, paragraph 2h: Diffusion).

If there is a vertical movement of electrons, such that w is the mean vertical electron drift velocity, a movement term $\frac{d}{dh}(n_e w)$ comes into the continuity equation. Here, h is the vertical distance co-ordinate. Accordingly, $\frac{dn_e}{dt}$ has to be defined by this equation:-

$$\begin{aligned} \frac{dn_e}{dt} &= q - L - \frac{d}{dh}(n_e w) \\ &= q - L - n_e \frac{dw}{dh} - w \frac{dn_e}{dh} \end{aligned}$$

where L is the rate of loss of electrons by the mechanisms above. Such a drift velocity might be due to a change of temperature or to electromagnetic forces as well as to diffusion. The drift velocity appropriate to diffusion is: (see equation 19, chapter 1)

$$w = \frac{1}{2} F / m f \quad \text{where } f \text{ is the collision frequency}$$

$$\text{and where the net force } F = \frac{1}{n} \frac{dp}{dh} - mg = \frac{kT}{n} \frac{dn}{dh} - mg$$

$$\text{Then } w = D \left(\frac{1}{n} \frac{dn}{dh} + \frac{1}{H} \right) \quad \text{where } D = \frac{1}{2} kT / m f \quad \dots \text{Equn. 28.}$$

D being the diffusion coefficient.

The diffusion coefficient for electrons is greater than that for ions but the plasma diffuses as a whole with an ambipolar diffusion coefficient

D_{12} .

$$D_{12} = 2D_+$$

$$H = 2H_+$$

(The mean molecular ion-electron mass is $\frac{1}{2}m_+$.)

The earth's magnetic field largely prevents diffusion across the lines of force. Considering vertical gradients, D_{12} is proportional to the square of the sine of the angle of inclination of the magnetic field. Diffusion can introduce either a positive or a negative movement term into the continuity equation. If an electron profile were parabolic, at the peak diffusion would increase the electron density if the ratio half thickness to scale height were greater than 2 and decrease it if less than 2.

d. WAVE PROPAGATION THROUGH THE IONOSPHERE.

Consider the electric vector of a wave travelling through the ionosphere:-

$$E = E_0 \sin 2\pi ft$$

where f is the frequency of the wave being propagated. If u_t is the instantaneous velocity of an electron in the direction of the electric field, then:-

$$m_e \frac{du}{dt} = E_0 e \sin 2\pi ft$$

For a suitable choice of $t = 0$:-

$$u_t = - (E_0 e / m_e 2\pi f) \cos 2\pi ft$$

This gives rise to a convection current density due to electron motion given by:-

$$n_e e u = - (E_0 n_e e^2 / m_e 2\pi f) \cos 2\pi ft$$

There is also a displacement current associated with the fluctuation of E given by:-

Figure 14a. Night Time Ionogram.

To face page 46.

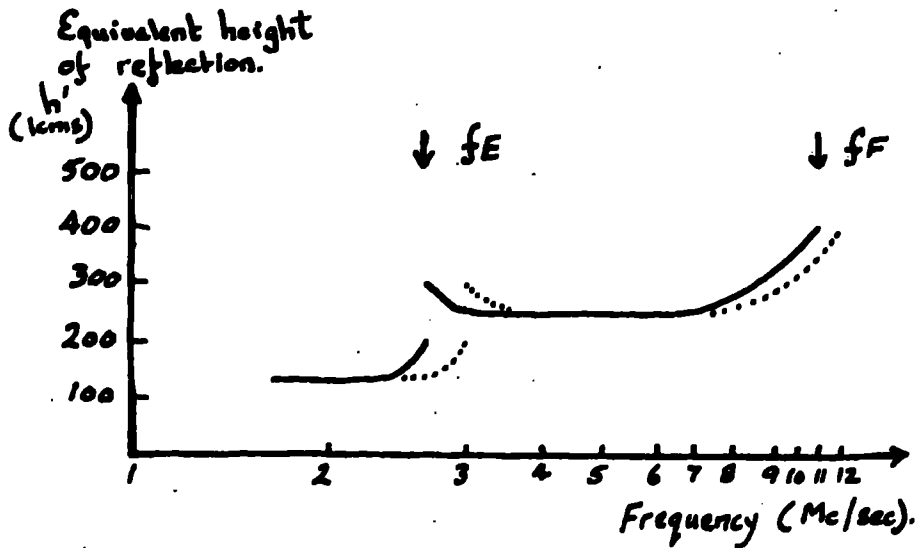

Figure 15a. Corresponding Electron Profile.

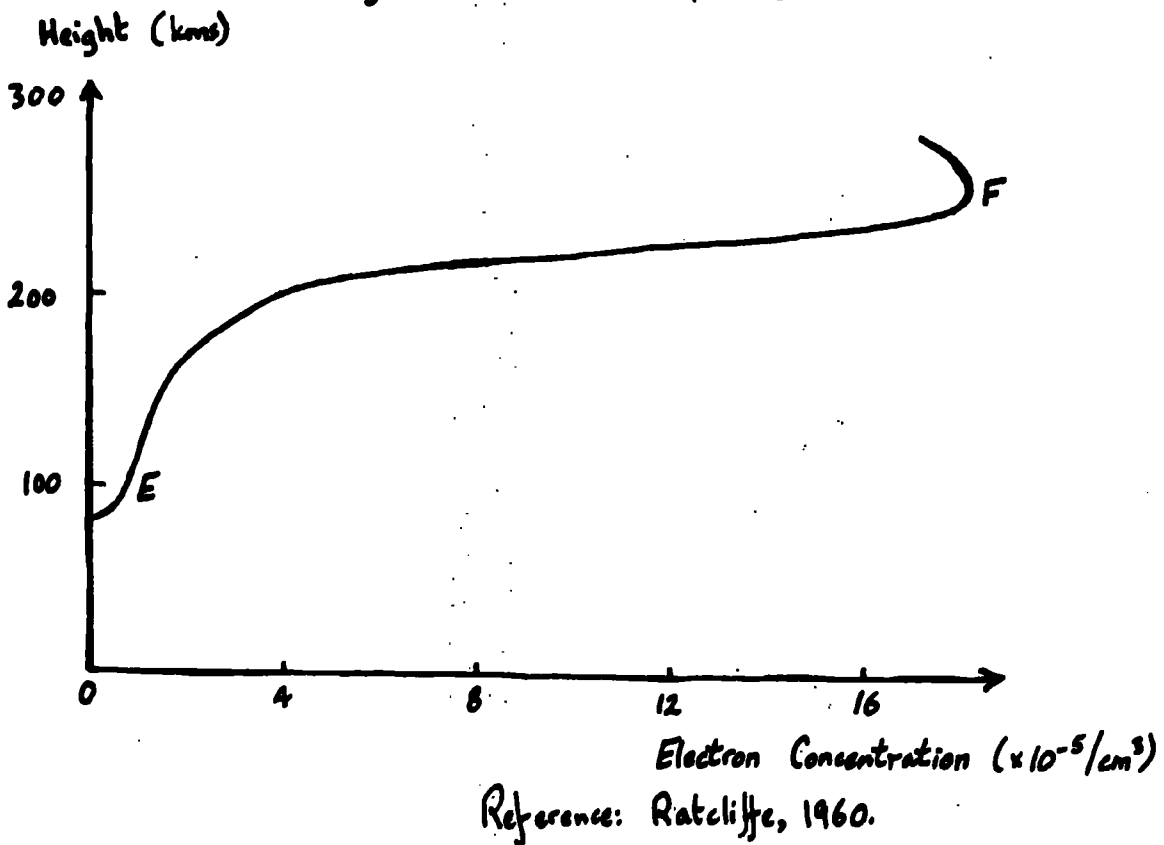

Figure 14b. Day Time Ionogram.

To face page 46.

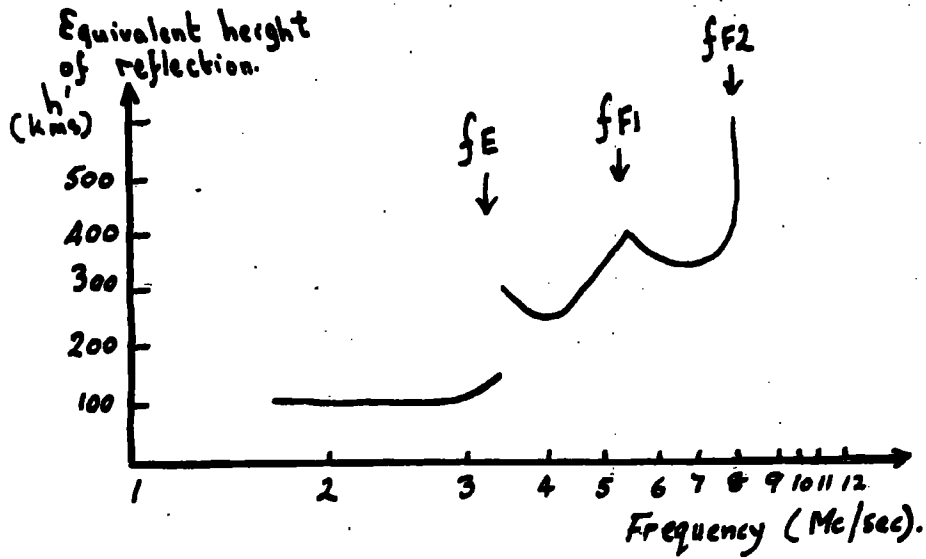
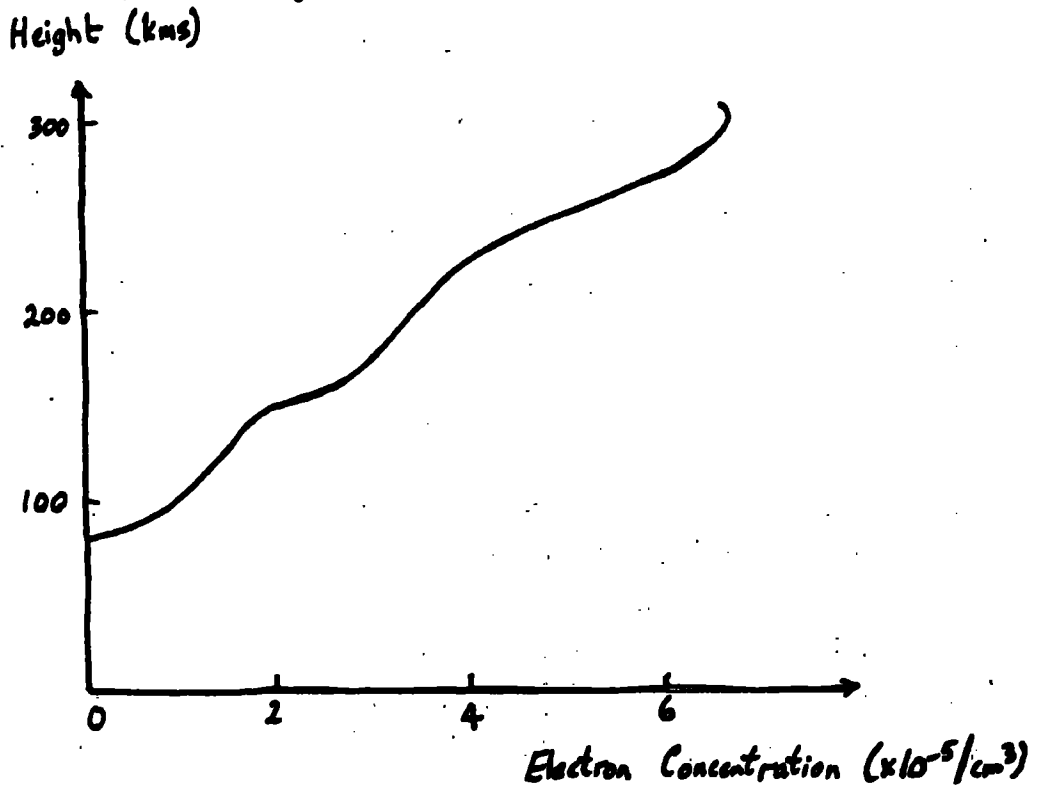

Figure 15b. Corresponding Electron Profile.



Reference: Ratcliffe, 1960.

$$\epsilon_0 \partial E / \partial t = \epsilon_0 E_0 2\pi f \cos 2\pi f t$$

The total current is then:-

$$I = (\epsilon_0 - n_e e^2 / m_e (2\pi f)^2) E_0 2\pi f \cos 2\pi f t$$

..... Equn. 29.

The "penetration frequency" f_p has this meaning:- Only waves with frequencies lower than the penetration frequency can be reflected if the wave is incident vertically. This penetration frequency follows immediately from this equation for the vertical wave will not be propagated if the current is zero.

Thus:-

$$n_e = k f_p^2 \quad \text{where } k \text{ is a constant.}$$

..... Equn. 30.

Thus by studying the time delay between the emission and reception of a wave it is possible to plot "ionograms" showing the variation of equivalent height for reflection (assuming free space velocity for the waves) with frequency, and from these to deduce electron profiles (see figures 14 and 15). Discontinuities in the ionogram correspond to turning points in the electron profiles. Because of the presence of the earth's magnetic field, the ionosphere is birefringent. The dashed line in the ionogram represents the extraordinary wave.

The critical frequency of the F2 region behaves in a peculiar manner, not because the processes of electron production are unusual, but because there are large-scale vertical movements of the electrons.

The first order theory of the E and F1 regions is explained in terms of photoionization and recombination. The E layer is probably formed by absorption of soft X-rays in air, and the F1 ledge by the absorption in atomic oxygen of ultraviolet radiation (100 to 600 Å). The critical frequency of the F2 region is so irregular that it is usually discussed in terms of "anomalies". The F2 peak results from

Figure 13. Electron Profile Variation.

To face page 47.

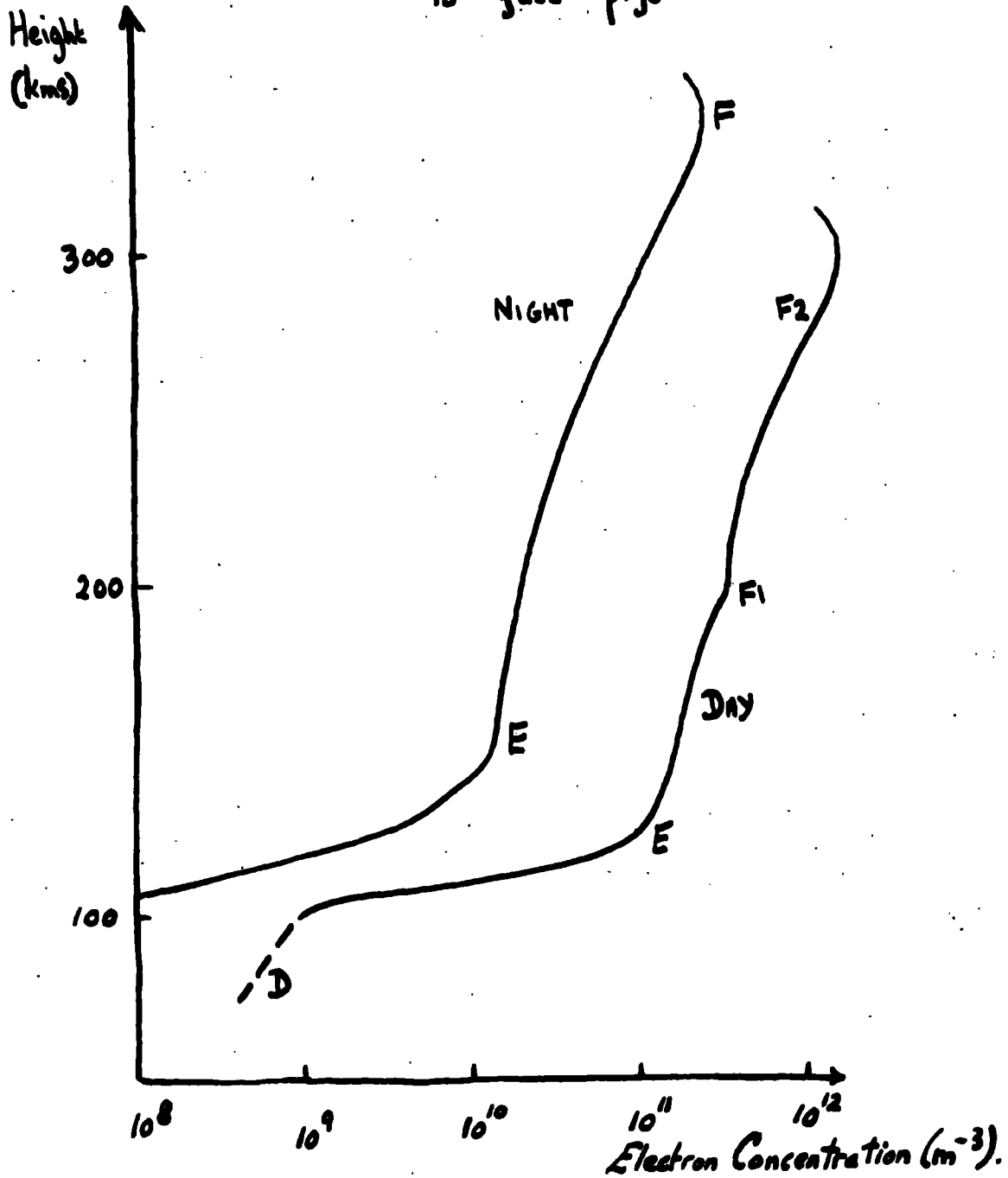

Day and night variation of the electron profile (Handbook of Geophysics, 1957), as determined experimentally by means of rockets.

the diffusion of the electrons. Ignoring loss and production, if there is a uniform electron concentration, the highest electrons, having the greatest diffusion coefficient, will fall most rapidly. Low electrons do not fall, so a peak is formed which falls slowly to the ground. In the F layer, movements of large irregularities may not represent electron motion but may constitute a compression wave, the cause of which is not known. Part of the drift in the F layer is caused by the "motor" effect. (See chapter 4, paragraph 2f).

The continuity equation for the electron density in the F region of the ionosphere can be solved by the use of an electrical analogue (Briggs and Rishbeth, 1961). This employs a series of condensers, the charge on any one of which represents the electron density at a certain height. The condensers form part of a network which contains resistors whose values are related to the vertical diffusion and loss coefficients. The diurnal variation of production of ionization is represented by the supply of current from potentiometers, varied periodically by an assembly of cams. The voltage on each condenser is recorded by a pen-recorder, and represents the variation of electron density at the appropriate height.

Comparison of the solutions with the actual ionosphere may show the extent to which additional movement, caused by electromagnetic forces and diurnal temperature changes, are important.

Figure 13 shows the general day and night variation of electron profile, experimentally determined by rockets.

A STUDY OF METHODS OF MEASUREMENT OF THE ELECTRIC CHARGE ON A ROCKET
AND OF AMBIENT ELECTRIC FIELDS USING PROBE TECHNIQUES.

SECTION 1. SURVEY OF LITERATURE.

CHAPTER 4. ELECTRIC FIELDS.

	Page No.
1. THE SIGNIFICANCE OF ELECTRIC FIELDS IN THE UPPER ATMOSPHERE	49
2. THE ORIGIN OF ELECTRIC FIELDS	50
a. Motions in the Ionosphere	51
b. Rotation of Earth	51
c. Tidal Motions in the Atmosphere	51
d. Resonance Theory	52
e. Magnetic Variations	52
f. Atmospheric Electromagnetic Machinery	53
g. Electric Fields.	55

CHAPTER 4. ELECTRIC FIELDS.

1. THE SIGNIFICANCE OF ELECTRIC FIELDS IN THE UPPER ATMOSPHERE.

There can be no doubt that the electrical state of the lower atmosphere is self-contained between the earth and the ionosphere. Solar flares, sunspots, magnetic storms and aurorae have no effect on atmospheric electricity.

Before the advent of extensive rocket research (about 1957) information concerning electric fields and space charges in the upper layers of the atmosphere was almost completely lacking. Data on electrical fields and space charges was urgently needed for the solution of certain problems, (Imyanitov, 1957).

It was hoped to form a complete theory of the aurora polaris, to prove the theories of magnetic storms, and to demonstrate the entry of charged particles into the earth's atmosphere. Other questions discussed were: Is the earth together with the atmosphere a neutral body in space; and is the electrification of the earth and atmosphere due to extra-terrestrial sources? Of course, the latter is possible, with cosmic ray ionization and solar heating.

The presence of a field increasing in the direction earth to sun would indicate the existence of an electric field created by the sun. The distribution of the electric field was also needed to decide whether the stream of particles moving from the sun is charged or uncharged.

The causes of the appearance of fast, charged particles in the atmosphere and the nature of cosmic rays were not clear. The earth might act as a gigantic linear accelerator of charged particles, *it was thought.*
~~(see chapter 1, paragraph 10)~~

With the advance of rocket research such theories as the existence of the van Allen radiation belts and the penetration of the solar plasma into space beyond the distance of the earth have been established.

It seemed to Krassovsky (1959) that in explaining the heating of the Upper Atmosphere one should keep in mind the possibility of its being heated at the expense of electric currents in the ionosphere. Other modern ideas are discussed (in chapter 2, paragraph 13), based on results obtained with lunar rockets.

It would seem that the most important reason for measuring the ambient electric fields in the vicinity of a rocket is to further develop the dynamo theory (see chapter 4, paragraph 2f:- Atmospheric Electromagnetic Machinery). The vehicle charge is of interest in that it affects this measurement, and also it may have some bearing on rocket detection.

2. THE ORIGIN OF ELECTRIC FIELDS.

The general application of the dynamical equations to the atmosphere has already been presented (chapter 1, paragraph 3d). In this chapter, the theory of origin of ionospheric electric fields is developed. In the ionosphere particle motion is controlled by electromagnetic forces. The upper atmosphere rotates with the earth since the geomagnetic field is confined by the effects of electric currents in a transitional layer within ten earth radii.

If, as Kelvin (1882) postulated, the atmosphere has a natural mode of oscillation with a 12 hour period, there is the possibility of a resonant response to tidal forces in the atmosphere. The idea of an electric current system in the upper atmosphere due to tidal movements of conducting air across the earth's magnetic field was developed to explain the regular fluctuations of this field.

In all aspects of meteorology, the atmosphere should be thought of as a great engine, but one which is delicately balanced. The upper atmosphere must be pictured as a piece of electromagnetic machinery, in which the E region behaves as a dynamo and the F region as a motor.

Figure 16. Atmospheric Tidal Motions.

To face page 51.

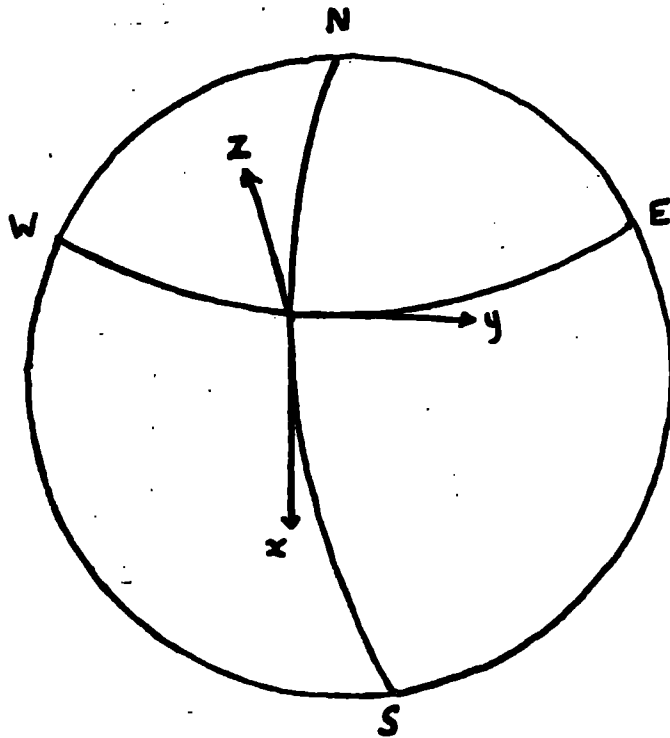

Tides give rise to a variation of pressure on the ground, and hence to a ground air velocity. Let v_{x0}, v_{y0} be the components of this velocity. Then:-

$$v_{x0}, v_{y0} = f(\lambda_L, \theta_L)$$

λ_L = longitude. θ_L = latitude.

Graphs are given of the electric field in these regions. The total electric field is of the order of 2×10^4 V/km according to the theory given. (See page 55.)

a. MOTIONS IN THE IONOSPHERE.

The motions of particles are ultimately responsible for electric fields in the ionosphere. The tendency for electromagnetic forces to dominate over the collisional forces characterises the ionosphere. Apart from the rotation of the earth and atmospheric tides (Hines, 1959) there are no established causal connections between motions within and beneath the ionosphere.

b. ROTATION OF EARTH.

Does the upper atmosphere rotate with the earth? The outer atmosphere would be held almost rigidly by the interplanetary gas if the geomagnetic field should penetrate the latter. But there is no westward wind increasing with height in the ionosphere. This is consistent with the idea that the geomagnetic field is confined within the earth's outer atmosphere by the effects of strong currents in a transitional layer within ten earth radii. The outer atmosphere is then free to rotate rigidly with the earth (Hines, 1959).

c. TIDAL MOTIONS IN THE ATMOSPHERE.

Tidal motions have been studied for more than two centuries. Tides give rise to a variation of pressure on the ground, and hence to a ground air velocity (Fejer, 1953). Let v_{x_0} , v_{y_0} be the components of this velocity (see figure 16). -Then:-

$$v_{x_0}, v_{y_0} = f(\lambda_L, \theta_L)$$

$$\lambda_L = \text{longitude} \quad \theta_L = \text{latitude.}$$

The solar semidiurnal component of pressure variation greatly exceeds the lunar semidiurnal component, although the tide producing gravitational force of the moon is about twice that of the sun (Hines, 1959). Thermal effects must be considered, and in fact the diurnal thermal input,

Figure 17. Atmospheric Resonance Theory.

To face page 52.

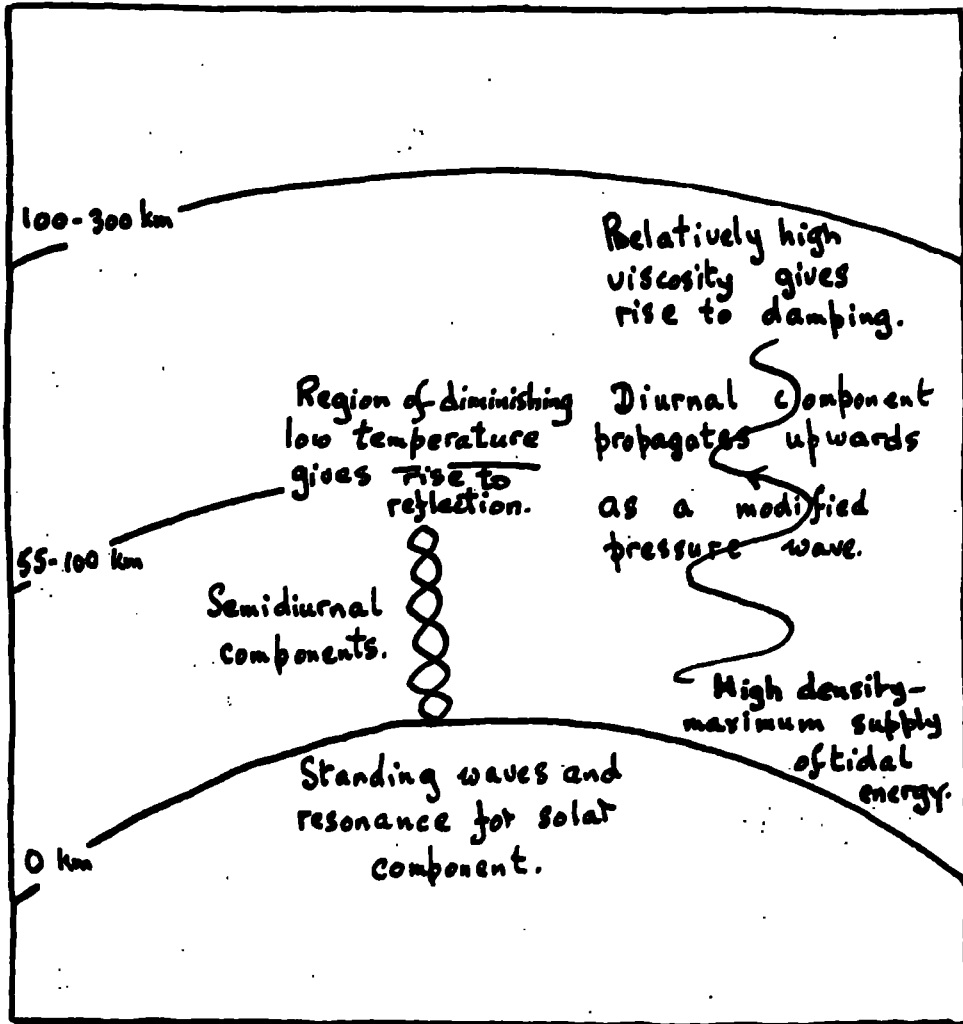

Author's diagram

acting in conjunction with the semidiurnal motion, may actually control the period of the earth's rotation (Holmberg, 1952). Kelvin (1882) discussed the thermodynamic acceleration of the earth's rotation. He postulated that the atmosphere has a natural mode of oscillation with a 12 hour period, hence there is the possibility of a resonant response.

d. RESONANCE THEORY.

A satisfactory resonance theory has been developed (Weekes and Wilkes, 1948). There are circumstances in which the tidal energy supplied to the atmosphere through the action of tide-producing forces can be trapped between a certain stratum (usually where the temperature has a minimum) and the ground. For a model atmosphere, bounded at the top by a perfect barrier the amplitude of the oscillation at resonance is infinitely great. If the temperature rises again above the minimum the barrier will be partially transparent and energy will leak through, to be finally absorbed at a high level where the effects of viscosity and thermal conduction become important. The variation of barrier thickness affects the sharpness of resonance (see the temperature graph, figure 6). The sharpness of resonance is controlled by the distance a_t (shown in figure 6). If a_t is 30 km, the magnitude of the tide is 160 times the equilibrium tide; if a_t is 10 km, it is 10 times the equilibrium tide.

e. MAGNETIC VARIATIONS.

The earth's magnetic field is given by the following equations (Millet Morgan, 1959).

$$B = \mu_0 H \quad \mu_0 = 4\pi/10^7 \text{ H/m}$$

Let M_e be the ^{moment} mass of the earth. Then:-

$$H = \frac{1}{3} M_e R^3 \text{ grad } \frac{\cos \theta}{r^2} \text{ amp/m.} \quad \dots \text{ Equn. 31.}$$

Figure 18. The Geomagnetic Field.

To face page 53.

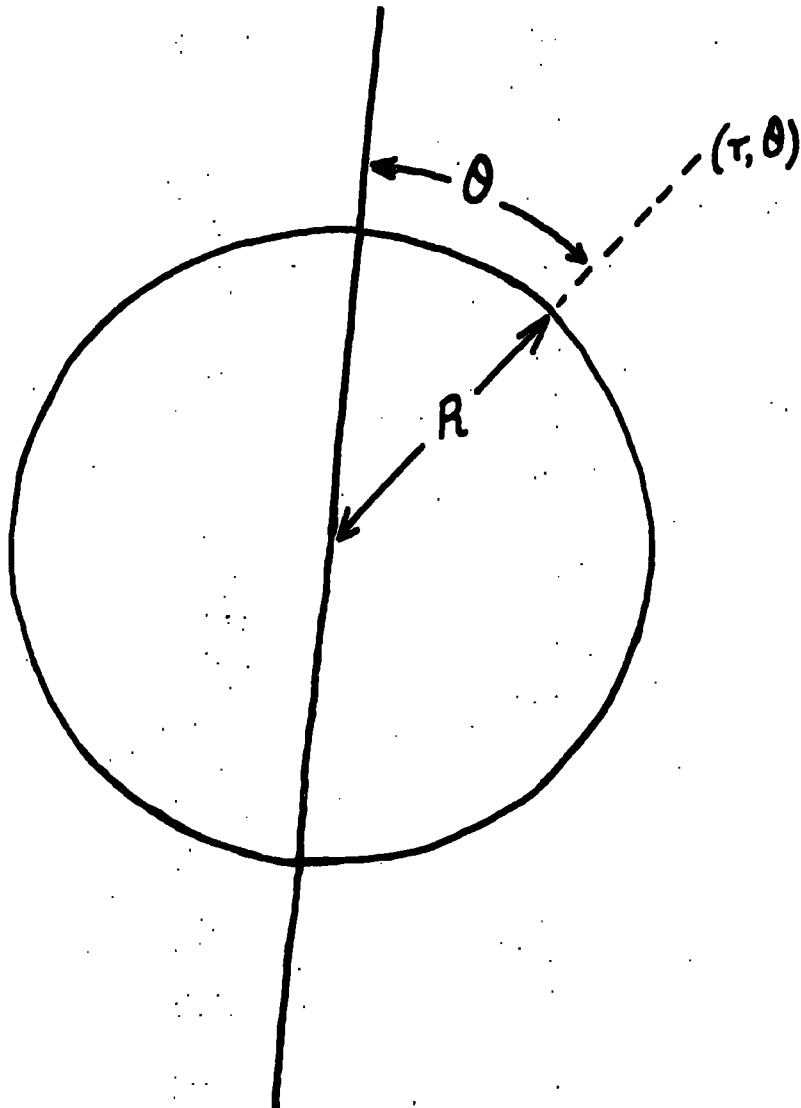

$$H_r = \frac{1}{3} \frac{2M_e \cos \theta}{r^3} R^3$$

$$H_\theta = \frac{1}{3} R^3 \frac{M_e \sin \theta}{r^3}$$

$$H_e = \frac{1}{4\pi} \frac{0.935 \text{ amp/m}^2}{R} \quad R = 6.37 \times 10^6 \text{ m.}$$

The radial component of H is given by:-

$$H_r = \frac{1}{3} R^3 \frac{2M_e \cos \theta}{r^3}$$

and the azimuthal component by:-

$$H_\theta = \frac{1}{3} R^3 \frac{M_e \sin \theta}{r^3}$$

The magnetic intensity at the ionosphere is 10% lower than at the earth's surface. The data at present available indicate that less than 1% of the earth's surface magnetic field is of external origin (Chapman, 1951).

Regular fluctuations of the earth's magnetic field are believed to be due to a current system in the upper atmosphere. As already noted, tidal oscillations have been studied for more than two centuries (Fejer, 1953). Balfour Stewart in 1882 and Schuster in 1906, argued that the currents are probably due to tidal movements of conducting air across the earth's magnetic field. Chapman in 1919 estimated the conductivity of the atmosphere to explain magnetic variations assuming the tidal speed to be at all heights the same as on the ground. Appleton in 1937 found that the conductivity of the ionosphere calculated from radio measurements was far below this estimate. Taylor in 1936 and Pekeris in 1937 showed that tidal oscillations of the atmosphere could occur to cause very much greater wind velocities at great heights than on the ground; these could be more than 100 times greater in the absence of damping. Salzberg and Greenstone in 1951 and Phillips in 1952 provided experimental confirmation of this and obtained a factor of 100. Cowling in 1945 and Bates and Massey in 1951 find a factor of 6000 is needed to explain the magnetic variations.

f. ATMOSPHERIC ELECTROMAGNETIC MACHINERY.

The neutral particles in the atmosphere are set in motion by solar and lunar gravitation and by thermal forces. Charged particles,

sharing in this motion, move through the earth's magnetic field. This process takes place in the E region of the ionosphere, which accordingly acts in the same way as a dynamo (Ratcliffe, 1960b). Currents in this region are responsible for changes in the magnetic field at the ground, and they are accompanied by an electrostatic field. Because these currents flow in the geomagnetic field, the plasma is set in motion by a process which corresponds to armature reaction in a dynamo. The complexity is increased by the circumstance that ionization, and the dynamo electromotive force ($\underline{v}_a \times \underline{B}$, where \underline{v}_a is the air velocity), vary over the surface of the earth and with height. The electric field of horizontal and vertical distributions of space charge, built up before currents can flow, will modify the conductivity.

The horizontal distribution of space charge produces an electric field which influences the F region. If the ionosphere were pictured as two slabs - the E and F regions - of highly ionized gas separated by a weakly ionized layer, this field would reach the F region through a weakly ionized intervening region, where the conductivity would be predominantly along the lines of magnetic force. In the F layer, therefore, there would be a horizontal electromotive force due to charges conducted along these lines of force from the horizontal space charge in the E region. This electromotive force would then produce horizontal currents determined by the horizontal layer conductivity in the slab which represents the F region.

Thus the F region may be thought to behave like an electric motor, because the electric field in the E region gives rise to currents in the F region, and the presence of the geomagnetic field causes the plasma to move.

Recent research into electron profiles (see chapter 3) has shown that the slab model is a very poor approximation to the actual ionosphere, and therefore a mathematical discussion in terms of this picture will not be given here. The details of the theory have been

Figure 19.

Electric Field Components.

To face page 55.
Phase (hours).

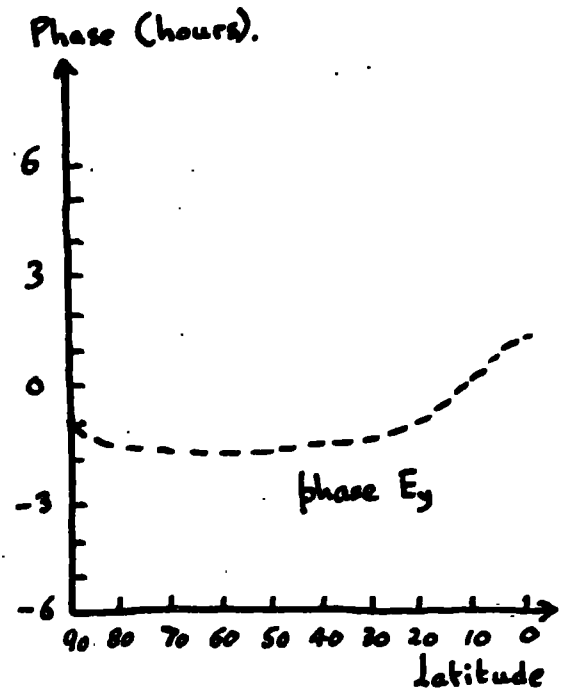
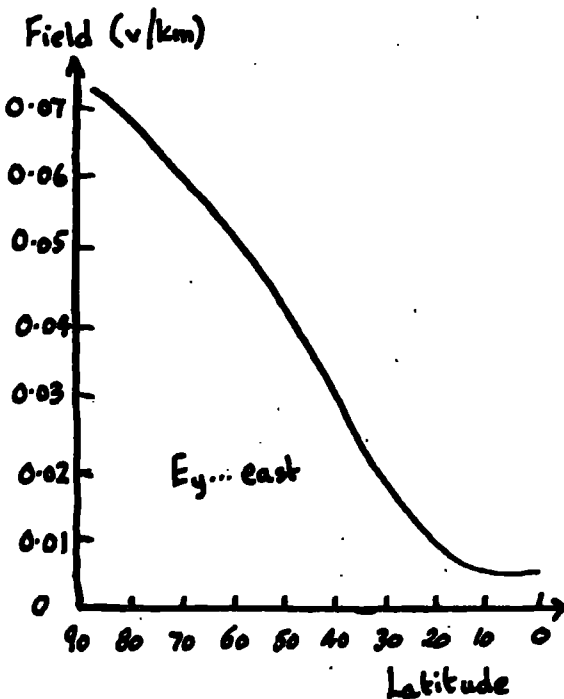
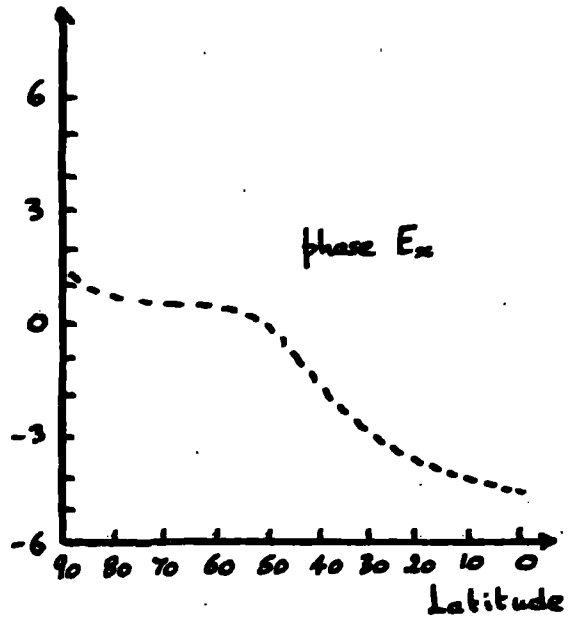
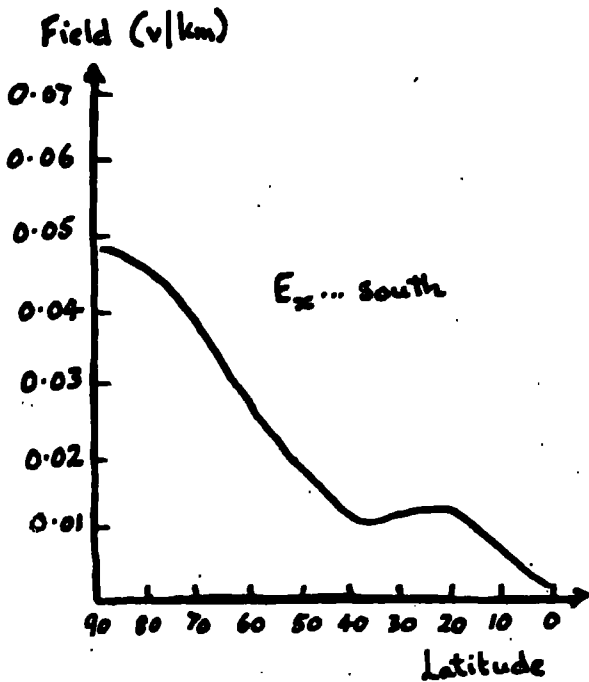

Reference:- Fejer, 1953.

Figure 2a Field Strength Reduction.

To face page 55.

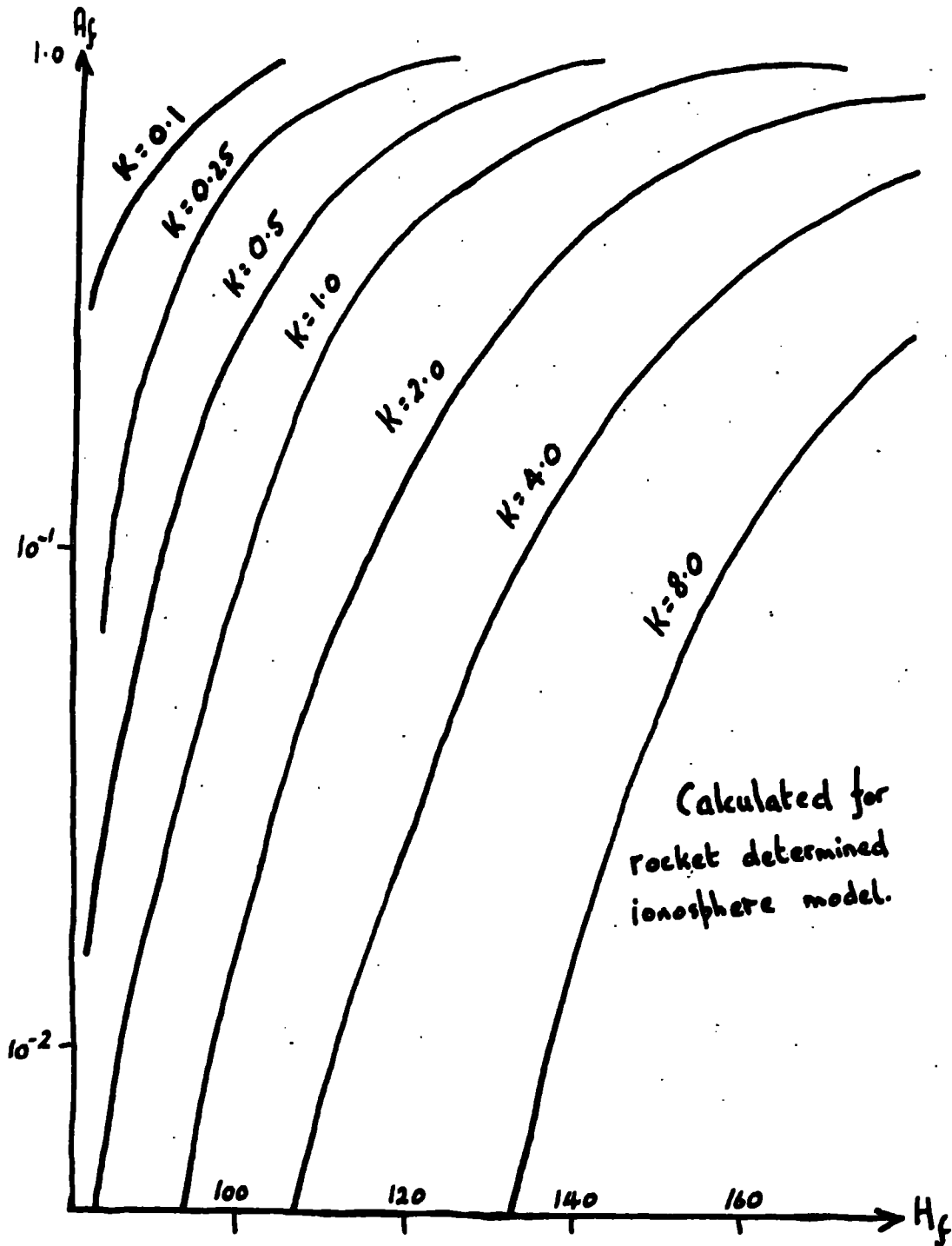

Reference: Farley, 1959. The coordinates are defined in the text.

set down by Ratcliffe (1960), and these include a discussion of conductivity.

g. ELECTRIC FIELDS.

The calculated total electric field components E_x , E_y as functions of latitude (Fejer, 1953) are given in figure 19. It shows the maximum values of the field components and the number of hours by which the maxima lag behind the maximum atmospheric pressure. If the ionospheric air tide differs in amplitude by a known factor (60) and in phase by a known number of hours from the ground tide, then the amplitude must be multiplied by the tidal amplification factor, and the phase difference between ionosphere and ground air tides must be added to the phases shown. The solar atmospheric tide in the E region is in phase with the tide on the ground, but the lunar tide in the E region is in phase opposition to the ground tide.

Consider now the production of fields in the F region (Farley, 1959), Farley begins his consideration of the electrostatic fields by noting that the ionosphere is anisotropic. (The geomagnetic field restricts charge motion perpendicular to the lines of magnetic flux but has no effect on motion parallel to these lines). He then notes that the ionosphere is inhomogeneous. (Conductivity depends on height). He arrives at the result that it is possible, under certain conditions, for say a horizontal electric field 3 km in extent, at 120 km height to give in the F region a similar field not greatly attenuated. Figure 20 shows the field strength reduction, where:-

- $1/K$ = spatial period/ 2π source field in km.
- A_f = field strength at 300 km/source field strength.
- H_f = height of source field in kms.

A STUDY OF METHODS OF MEASUREMENT OF THE ELECTRIC CHARGE ON A ROCKET
AND OF AMBIENT ELECTRIC FIELDS USING PROBE TECHNIQUES.

SECTION I. SURVEY OF LITERATURE.

CHAPTER 5. PROBE THEORY.

	Page No.
PLASMAS AND PROBES.	57
OUTLINE OF THE CHAPTER.	57
1. EARLY WORK ON PROBE THEORY.	59
a. Current to a Negative Probe in a Plasma.	59
b. Ion sheath about a negative probe.	60
c. Concept of Positive Column Electrons.	61
d. Determination of Space Potentials.	61
e. Plane Probe Characteristic.	62
f. Interpretation of Plane Probe Characteristic.	62
g. Probe providing an accelerating field for electrons.	63
h. Probe providing a retarded field for electrons.	63
i. The Space Charge Sheath Equation.	64
j. Determinations from Probe Analysis.	64
k. Limitations of Probe Measurements and Disturbing Factors.	66
l. Spherical and Cylindrical Probes.	67
m. Velocity Distribution obtained from Probe Characteristics.	67
n. Electron Velocity Distribution.	67
o. Large Random Ion Currents.	68
p. The Sheath Edge Paradox.	69
q. Revised Concepts of Plasmas and Collection Process.	69
2. MODERN WORK ON PROBE THEORY.	70
a. Electron Energy Distribution.	70
b. Sheath Formation Criterion.	72
c. Positive Ion Collection	73
d. Presence of Negative Ions.	75
APPENDIX - THE MOVING HEMISPHERE CURRENT EQUATIONS.	77

CHAPTER 5. PROBE THEORY.

PLASMAS AND PROBES.

An ionized gas of zero net charge is called a plasma. A metal test body, which should be at least two orders of magnitude smaller than the volume of the plasma in which it is immersed, is called a probe. This section is concerned with the study of plasmas using the electrical characteristics of such probes.

At a point in a plasma, there is a certain space potential. Here, potential has the same meaning as in elementary electrostatics. An insulated probe is said to assume a floating potential, and it is important to emphasise that such an insulated probe, in a plasma, does not assume the space potential. Instead a sheath of unipolar electric charges is formed about it.

The kinetic energy associated with the random motion of ions and electrons in a plasma is represented by an equivalent ion and electron temperature. It is this random motion which enables us to speak of random current densities for each charge species.

This section begins with an essentially historical account of work done before 1939, mostly by Langmuir and his collaborators, working in the Research Laboratory of the General Electric Company at Schenectady, and also by Spencer-Smith (1935) and Dürwang, and van Berkel (1938). Then a summary is given of modern work on probes which Boyd and his collaborators have carried out at University College, London.

OUTLINE OF THE CHAPTER.

A probe floating in a plasma does not assume the space potential. If the ion and electron current densities to a probe were determined by the random current densities in the plasma an electrode would run negative and the flow of ions to the collector would be controlled by the space charge which they produced in its neighbourhood.

From the current-voltage characteristic of a plane probe it is possible to find the space potential. Also the electron constants and the space potential may be found from the electron current in a retarding field.

Plane probe measurements are limited by various factors and disturbances and so experiments have been carried out using spherical and cylindrical probes.

The characteristics of a collector of small enough radius have been used to distinguish between the different types of ion velocity distribution.

There was much evidence for the idea that the electron velocity distribution in a plasma might be Maxwellian. Despite the evidence in favour of a large random ion current, it was thought unreasonable that the ion energy should even approach the electron energy.

The existing theory led to another paradox - that a predominance of negative charge at the sheath edge requires positive curvature in the potential distribution curve there, thus making it impossible to merge the sheath into the plasma.

A new description attributed the ion velocities to the electric fields through which they passed. The presence of an electrode in contact with the discharge was held responsible for the ion current flowing to it, by reason of its influence, as a boundary condition, on the potential distribution in the plasma.

Suppose we have a current-voltage characteristic for a probe, so that the current equals $f(V)$. Then, as Boyd and Twiddy (1954) have pointed out, the electron energy distribution function depends on the second derivative - $f''(V)$ - of this function. If $f''(V)$ is plotted against (V) it is possible to find the space potential with greater accuracy than that obtained in earlier methods. This approach to probe theory also yields new methods of finding the electron concentration.

Boyd and Thompson (1959) have shown that for a sheath to exist about a negative probe a certain criterion must be satisfied. Unless this criterion is satisfied the probe field will penetrate into the plasma and modify the energy distribution until the criterion is satisfied. The important consequences of this are (i) that orbital motions of the ions need not be considered since at the sheath edge their velocities are almost wholly normal to the edge, and (ii) that the flux of positive ions into the sheath is determined by the electron temperature, because it is this which determines the electric field which penetrates beyond the sheath edge and draws in the ions.

The sheath is enlarged by the neutralizing effect of electrons which penetrate into the sheath edge.

Rocket-borne Langmuir probes encounter plasmas which contain negative ions (i.e. which are weakly electronegative). Accordingly, the effect of the presence of negative ions is finally discussed.

1. EARLY WORK ON PROBE THEORY.

a. CURRENT TO A NEGATIVE PROBE IN A PLASMA.

It had been observed that negatively charged probes in a plasma take up a current which had been ascribed to electron emission by either positive ion bombardment or the photoelectric effect. Langmuir (1923) showed that these effects are both negligible.

According to the kinetic theory of gases the random current densities in a plasma due to positive ions and electrons are related in this way

$$\frac{j_e}{j_+} = \frac{v_e}{v_+} = \left(\frac{m_+}{m_e} \right)^{\frac{1}{2}} \quad \dots \text{Equn. 32.}$$

where j_e is the random electron current density, j_+ is the random positive ion current density, v_e is the average electron velocity, v_+ is the average positive ion velocity, m_+ is the mass of the positive ions, m_e is the mass of the electron.

(See chapter 1, equn. 9; thermal equilibrium between ions and electrons is assumed).

From this equation the random electron current density is seen to be very much greater than the random positive ion current density.

Ignoring the question of a sheath, a plane insulated probe immersed in a plasma should become more and more negative until the electron current is reduced to the same value as the positive ion current. A probe more negative than this would draw in positive ions.

b. ION SHEATH ABOUT A NEGATIVE PROBE.

Up to about 1939 it was believed that the flow of ions to a negative probe is controlled by the space charge which the ions give rise to in the probe neighbourhood. This neighbourhood^{ing} region is called a sheath. The modern concept of positive ion collection is that the ion current is determined mainly by the electric field which penetrates beyond the sheath edge. The consequences of this idea are developed in the second part of the chapter. (See paragraph 2c: Positive Ion Collection).

Consider first of all a simplified model of the sheath in which there is a sharp boundary between the sheath and the plasma. Then the situation is analogous to a system in which a plane electrode is emitting ions at the sheath edge. So Child's law can be applied, but it must be modified to relate to an ion source rather than the usual electron source. The maximum positive ion current density (j_p) and the voltage drop (V) and the distance across this space charge sheath (z) are related (in the absence of collisions) in the following manner:-

$$j_p = \frac{V^{3/2}}{z^2} \frac{4 \epsilon_0}{9} \frac{(2e)^{1/2}}{(m_+)^{1/2}} \dots \text{Equn. 33.}$$

The concept of the simplified model of the sheath, as used in the first part of this chapter, is as follows (see figure 21).

Figure 21. Concept of Sheath.

To face page 61.

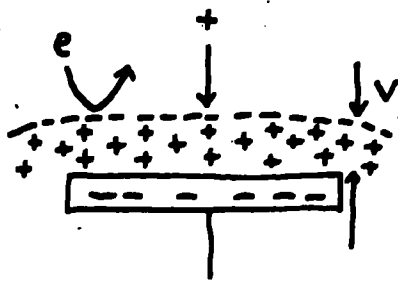

V = potential difference between probe and the sheath edge.

Figure 22. Probe Measurement Circuit.

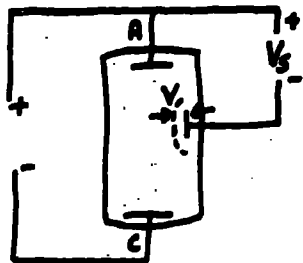

V_s = probe voltage.

(see page 62).

Author's diagrams.

All electrons are reflected at its outer edge and all positive ions which reach the outer edge are absorbed. The potential drop (V) between probe and plasma is confined to this sheath. Thus the sheath is seen to act as a screen, so that the field due to the probe charge does not extend beyond its edge. The positive ion current density to the probe is the same as the positive ion current density in the plasma.

The motion of charged particles in a fully ionised gas is influenced by the fields of ions, these fields being shielded by ions of opposite sign. (See chapter 1, paragraph 3a: Debye Length). In an electrolyte, at distances greater than λ_D the electric field of a point charge is shielded by particles of opposite sign, and the Debye length λ_D is the thickness of the ionic atmosphere about a stationary ion of opposite sign.

If λ_D is small compared with the other lengths of interest in an ionised gas, the gas is called a plasma. A sheath of roughly this thickness develops wherever the plasma is in contact with a solid surface. Within the sheath, electrical neutrality is not preserved.

c. CONCEPT OF POSITIVE COLUMN ELECTRONS.

Langmuir's picture of the positive column of the mercury arc, with which his experiments were done, was like this:- The electrons have velocities distributed in accordance with Maxwell's Law, and the directions of motion are distributed nearly at random. The average velocity of the electrons is approximately independent of the arc current but depends on the pressure. The wall of the tube absorbs all positive ions moving to it, but repels all but a minute fraction of the electrons. (The assumption of a Maxwellian distribution can now be tested by probe experiments.)

d. DETERMINATION OF SPACE POTENTIALS.

Langmuir (1923) described two simple methods for finding space potentials. The first method utilised the current-voltage-temperature

Figure 23. Plane Probe Characteristic.

To face page 62.

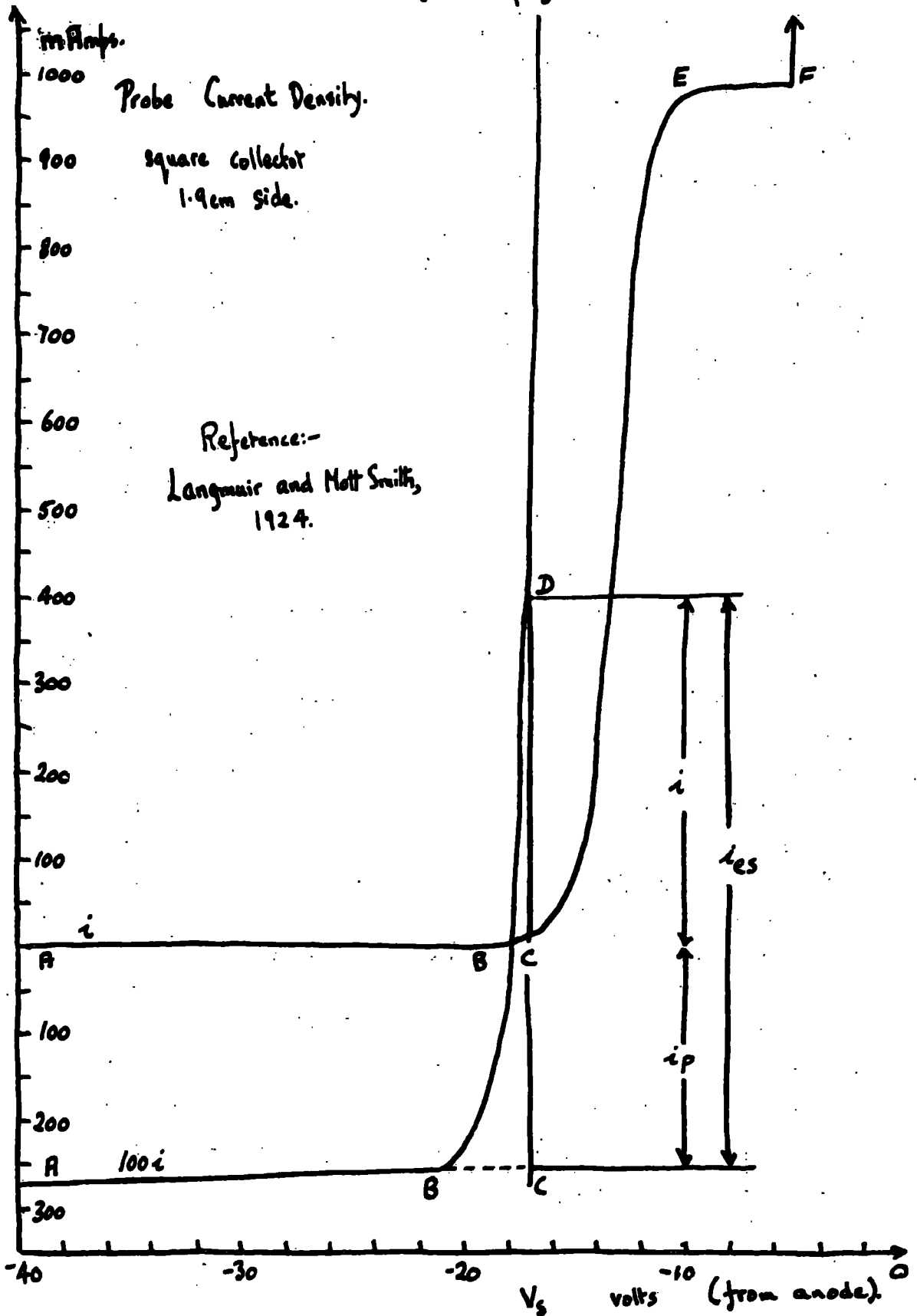

characteristics of a tungsten filament, but this was found unsatisfactory. His second method utilised the current-voltage characteristic of a cold probe, in a way which will be explained later.

e. PLANE PROBE CHARACTERISTIC.

In their studies of electric discharges in gases at low pressures, Langmuir and Mott-Smith (1924) considered the case of retarding and accelerating fields provided ^{for electrons} by plane, spherical and cylindrical probes. The form of the probe current density versus applied probe voltage curve is shown (figure 23) and also the sort of apparatus (figure 22) used to obtain it. Neglecting the contact potential between the anode and the probe, the probe voltage (V_g) is equal to the potential drop across the sheath (V) plus the voltage between the sheath edge and the anode (von Engel, 1955). In practice the characteristic obtained is for V_g and not for V .

f. INTERPRETATION OF PLANE PROBE CHARACTERISTIC.

Using the simplified sheath model, the characteristic (figure 23) may be interpreted as follows (Cobine, 1941). Ions and electrons can reach the probe except in the region AB where only positive ions can penetrate. E is the (ill-defined) turning point in the curve. In the region AE the probe has a positive space charge sheath. At C, the net current being zero, the thickness of the sheath is given by a "shielding distance" which is the thickness of a sheath about an insulated probe, λ_D . When the probe is at plasma potential (at E) it receives the entire random currents due to both the electrons and the ions in the plasma. The plasma extends to the probe surface, and the space charge sheath disappears. At F, where the probe voltage is high and positive, electrons in the sheath ionise the gas by collision giving slow positive ions, which annul the electron space charge.

(It should be noted that it is possible for the discharge to become drained of its electrons).

g. PROBE PROVIDING AN ACCELERATING FIELD FOR ELECTRONS.

In the region EF of the characteristic (figure 23) electrons are accelerated towards, and ions are reflected away from the probe. (If the positive ion temperature is much less than the electron temperature (see chapter 1, equn. 9), the positive ion current will quickly disappear with increasing positive voltages). An electron space charge sheath exists. Equation 33 gives the electron current density to a probe with a negative sheath, if the electron mass is substituted for ion mass. Since the probe is already receiving the entire random electron current of the plasma, an increase in the positive probe voltage will not give any increase in electron current.

In the region near a positive probe there are a large number of low velocity electrons, resulting from collision processes. These are trapped within this region by the accelerating field. Thus such an accelerating field provides a current density which increases near the probe.

h. PROBE PROVIDING A RETARDING FIELD FOR ELECTRONS:

Still using our simplified model (see paragraph 1b of this chapter), the electric field about a highly negative plane probe falls off to zero at the boundary of the sheath. The probe is subject only to a random ion current density,

$$j_p = \frac{1}{4} n_+ e v_+ \quad \dots \text{Equn. 34a.}$$

where n_+ is the ion density in the plasma. The random electron current density towards an imaginary plane in the body of the plasma is given by:-

$$j_e = \frac{1}{4} n_e e v_e \quad \dots \text{Equn. 34b.}$$

(See chapter 1, paragraph 2c: Knudsen's Cosine Law).

The concentration of electrons near the probe is small compared to the concentration in the body of the gas, but the velocity distribution

and temperature (that is to say, average energy) of the electrons must be the same in both regions. The electrons which reach the neighbourhood of the probe have lost kinetic energy by moving against the field, but these electrons were not average electrons but were those which originally had unusually high velocities.

i. THE SPACE CHARGE SHEATH EQUATION.

In our simple model, the difference in potential between the probe and the plasma is localized in a space-charge sheath of appropriate sign, across which the potential is controlled by the variation of positive charge concentration (Poisson's equation). Within the positive ion sheath the following equations apply:- Poisson's equation; a continuity equation relating positive ion current and positive charge concentration; and an energy equation for an ion which starts from rest at the sheath edge and gains kinetic energy from the electric field. From these equations it is possible to deduce equation 33, i.e. Child's Law. (Bleaney and Bleaney, 1957). The positive ion current given by equation 33 has to be multiplied by a factor $(1 + 0.025(T_+/V)^{1/2})$ to allow for the kinetic energy which the ions have on entering the sheath. T_+ is the temperature equivalent of this energy, assuming it has a Maxwellian distribution.

(Equations 33 and 34 (a) and (b) are consistent with the definition of Debye length if one makes the assumption that the potential energy of an electron changes by an amount something like kT in one Debye length).

j. DETERMINATIONS FROM PROBE ANALYSIS.

Using the probe current-voltage characteristic above (figure 23), the electron concentration and energy and the space potential may be found from the electron current in a retarding field, obtained by extrapolating the ion saturation current density for large collecting voltages to small collecting voltages, and assuming that the difference between the experimental and the extrapolated lines is the electron current (Emelius, 1951).

Boltzmann's relation for electron concentration may be applied to the region BE of the probe characteristic:-

$$n_{es} = n_e \exp(-eV/kT_e) \quad \dots \text{Equn. 35a.}$$

where n_{es} is the electron concentration at the probe surface, n_e is the electron density in the plasma, V is the potential drop across the sheath, and T_e is the absolute temperature of plasma electrons. Hence:-

$$j_{es} = j_e \exp(-eV/kT_e)$$

where j_{es} is the electron current density to a probe providing a retarding field.

$$\ln j_{es} = \ln j_e - eV/kT_e \quad \dots \text{Equn. 35b.}$$

ELECTRON TEMPERATURE.

This can be found from the slope of the curve representing equation 35b (i.e. with co-ordinates $\ln j_{es}$ and V). This is often referred to as the "semilog plot". (The validity of this conventional method of deducing the electron temperature by the retarding field method is unaffected by consideration of the penetration of the probe field beyond the sheath edge).

PLASMA POTENTIAL.

This is determined as the potential at which the Boltzmann relation breaks down - in other words, the characteristic becomes nonlinear - as the field becomes accelerating for electrons. This is not a very satisfactory approach to the problem of space potential as can be seen from the graphs in section II and also from this chapter (paragraph 2a: Electron Energy Distribution).

ELECTRON CONCENTRATION.

This may be found from the relation:-

$$j_e = \frac{1}{4} n_e e v_e = \frac{1}{4} n_e e (8kT_e / \pi m_e) \dots \dots \dots \text{Equn. 36.}$$

The electron concentration should really be obtained using one of the two methods indicated later on in this chapter (paragraph 2a).

POSITIVE ION TEMPERATURE.

This should certainly not be found from the corresponding equation for positive ions. (See paragraph 2b; Sheath Formation Criterion).

k. LIMITATIONS OF PROBE MEASUREMENTS AND DISTURBING FACTORS.

The space occupied by the sheath and the current which it draws must be small compared with the volume and current of the discharge. Probe theory is usually applied to discharges in which pressures are in the range 1 mm to 10^{-4} mm Hg, ion and electron concentrations are greater than $10^8/\text{cm}^3$, and currents are of the order of $1 \mu\text{amp}/\text{cm}^2$.

The behaviour of a negative plane probe is affected by effects at the edge of the probe. If the effective area increases with increase in negative voltage, the positive ion current will increase at the same time.

The plasma-probe potential drop (V) may depend on the rate at which observations are made, as for instance if the contact potential is due to a phenomenon which varies with time. Irregular readings may be due to contamination of the probe surface by adsorbed oxygen layers. Moreover, the surface resistance of a probe changes with its potential. Probe characteristics should be measured only after the probe surface has been cleaned by heating, and this heating may disturb the local gas density.^x

The probe surface is assumed to be a perfect absorber of all ions and electrons reaching it. In practice, secondary emission will take place. In other words, the "semilog plot" is displaced parallel to the voltage axis.

The ions and electrons are assumed to have a Maxwellian distribution of velocities. When Maxwellian distributions are superposed, the semilog plot consists of broken lines representative of each distribution. Thus the space potential is uncertain, and the concept of electron temperature

^x See van Berkel (1938), and Spencer-Smith (1935).

has no significance (see paragraph 2a: Electron Energy Distribution).

A substantial drift current density may complicate the results.

1. SPHERICAL AND CYLINDRICAL PROBES.

A plane probe disturbs the discharge as too much charge is removed from the plasma. Theories for cylinders collecting only ions of one sign (and under conditions such that the ion free path is much greater than the sheath radius) have been obtained. Cylindrical collectors of large diameter may give trouble because of end corrections. The analysis of characteristics obtained with cylindrical collectors (Engel and Steenbeck, 1932) is discussed in section II.

Fiebich in 1950 showed that when small cylindrical probes are used consisting of a short length of wire protruding from an insulating stem, the ion sheath formed around the stem covers part of the probe. The effective area can be deduced by surrounding the probe with a small metal tube whose potential is varied.

m. VELOCITY DISTRIBUTION OBTAINED FROM PROBE CHARACTERISTICS.

The characteristics of a collector of small enough radius can be used to distinguish between the different types of velocity distribution. Mott-Smith and Langmuir (1926) presented a theory relating the second derivative of the probe characteristic to the velocity distribution. (See Mott-Smith and Langmuir, 1926. p.753).

n. ELECTRON VELOCITY DISTRIBUTION.

Tonks and Langmuir (1929) provided a general plasma theory. By then there was much evidence for the idea that electron velocities in a gas discharge plasma have a Maxwellian Distribution. These velocities correspond to temperatures between 5000 and 70,000°K. Measurements depended on the Boltzmann density distribution which the electrons assume in the sheath about a negatively charged collector. This is valid if the electrode potential changes are confined to a sheath about the electrode.

c. LARGE RANDOM ION CURRENTS.

Such direct measurements on positive ions are not possible, but the saturation current to a collector at negative voltages indicates that the magnitudes of ion and electron velocities are similar.

It had been argued that since the potential drop is confined to the sheath, only those ions will be collected which are in any case moving towards the sheath edge.

Measurements with perforated probes had shown that the normal components of velocity of the ions in a plasma which reach the edge of a cathode are roughly those of a Maxwellian distribution corresponding to a temperature T_+ defined in the same way as electron temperature. For a given plasma this ion temperature is about half the temperature of the electrons.

In low pressure discharges the ions probably acquire practically all the kinetic energy they possess from the electric fields within the plasma. The momentum of the electrons is so small that ionising collisions of electrons with gas molecules cannot impart to the ions appreciable kinetic energy.

All the ions which reach the edge of a cathode sheath pass to the electrodes and thus only half of the ions corresponding to a Maxwellian distribution T_+ can be present in the plasma near the sheath edge, so that the directions of the ions can be distributed only over a hemisphere.

Using equations 34(a) and (b) and substituting temperature for velocity produces the equation:-

$$T_+/T_e = (i_p/2i_e)^2 m_+/m_e \quad \dots \text{Equn. 37.}$$

Measurements on a mercury arc gave a value of 0.55 for this ratio. But it is unreasonable that the ion energy should even approach the electron energy in view of the fact that it is the electrons primarily which supply energy to the rest of the plasma and the positive ions with their relatively large mass and frequent impact with slow atoms do not acquire large random

Figure 24 Sheath Edge Paradox.

To face page 69.

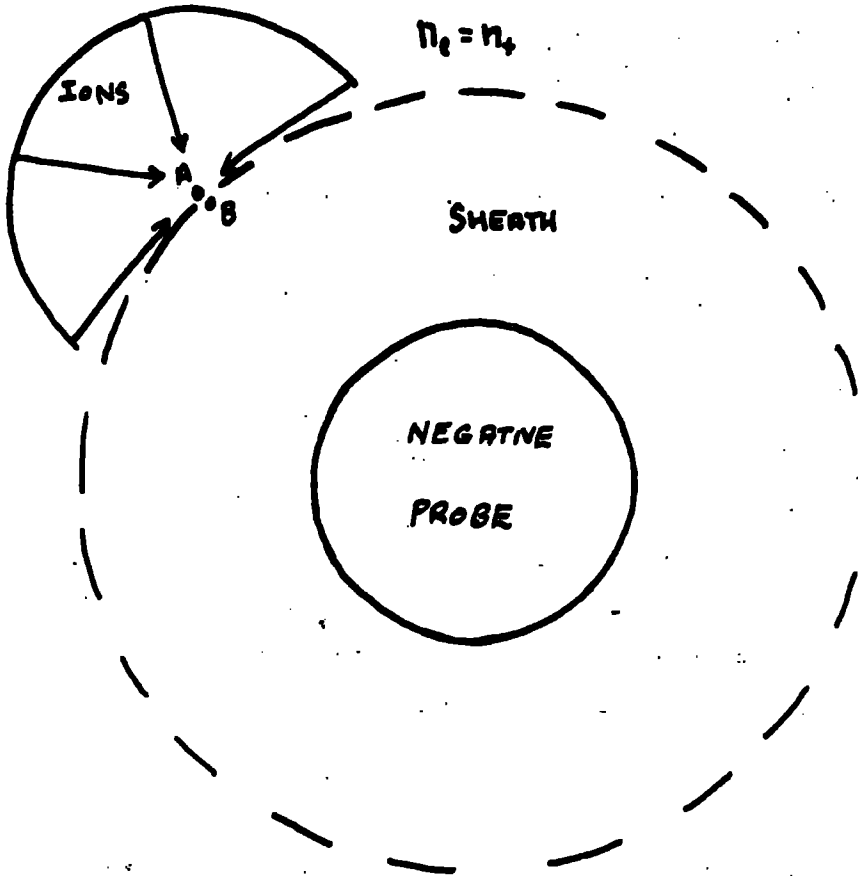

Author's diagram.

kinetic energies.

The sheaths on a spherical electrode immersed in a positive column are seen to be of equal thickness on cathode and anode sides, and this is evidence in favour of a large random ion current.

p. THE SHEATH EDGE PARADOX;

The sheath edge provides a paradox. The potential at B (figure 24) is lower than at A. The electron concentration will also be lower according to the Boltzmann Law, and, because of their greater average velocity, the ions will have a lower concentration. By Poisson's equation any predominance of negative charge at the sheath edge requires positive curvature in the potential distribution curve there, thus making it impossible to merge the sheath into the plasma.

q. REVISED CONCEPTS OF PLASMAS AND COLLECTION PROCESS.

Langmuir (1929) and Tonks (1929) came to accept a new point of view. Suppose the electrons possess a Maxwellian velocity distribution and also such a high mobility that they obey the Boltzmann Law irrespective of any drift. Further, suppose the positive ions are formed with negligible velocity and acquire velocities corresponding to the electric fields through which they pass.

For long ion free paths each ion will move freely under the influence of small plasma fields set up by the electrons and ions themselves, that is fields maintained by the balance of electron and ion charges. For short free paths, there are collisions between ions and atoms, but the ions are still mainly guided by the electric field.

It is the presence of an electrode in contact with the discharge which is responsible for the ion current flowing to that electrode. This is by reason of its influence, as a boundary condition, on the potential distribution in the plasma. (Very small electrodes have no effect on the potential distribution through the body of the plasma and can, therefore, be used as true probes.) Each negative body in contact with the discharge

is collecting ions from a definite region of the plasma only.

In order to handle this theory mathematically it is necessary to know the space distribution of the generation of ions.

In the plasma surrounding a fine negatively charged probe wire the potential difference between plasma potential maximum and sheath edge may be so small that the ions generated within the plasma potential maximum are not trapped but can traverse the maximum by virtue of their finite initial velocities. (This justified the use of a sufficiently fine negatively charged wire in the usual way to measure positive ion concentrations.)

A positively charged cylindrical probe collects electrons in the same manner as previously supposed, except that the sheath about it is considerably thickened by the presence of ions generated in the sheath.

2. MODERN WORK ON PROBE THEORY.

a. ELECTRON ENERGY DISTRIBUTION.

Suppose we have a current-voltage characteristic for a probe, so that $i_{\#} = f(V)$. If at any point on the characteristic we superimpose an alternating voltage (\bar{e}), the current is given by $i_{\#} = f(V + \bar{e})$. Expanding this by Taylor's theorem, we can express the current in terms of an infinite series of direct current and harmonic terms:-

$$i_{\#} = f(V + \bar{e}) = f(V) + \bar{e} f'(V) + \frac{\bar{e}^2}{2!} f''(V) + \dots$$

..... Equn. 38.

Thus with the potential at each point oscillating between $V + \bar{e}$ and $V - \bar{e}$ the rectified current is proportional to $f''(V)$. The second derivative of the characteristic can be obtained directly using a circuit such as that given by Sloane and McGregor (1934).

This is useful, because, as Boyd and Twiddy (1954) point out, for an isotropic distribution of electron energy, the distribution function is given by:-

Figure 25: Space Potential Conventions.

To face page 71.

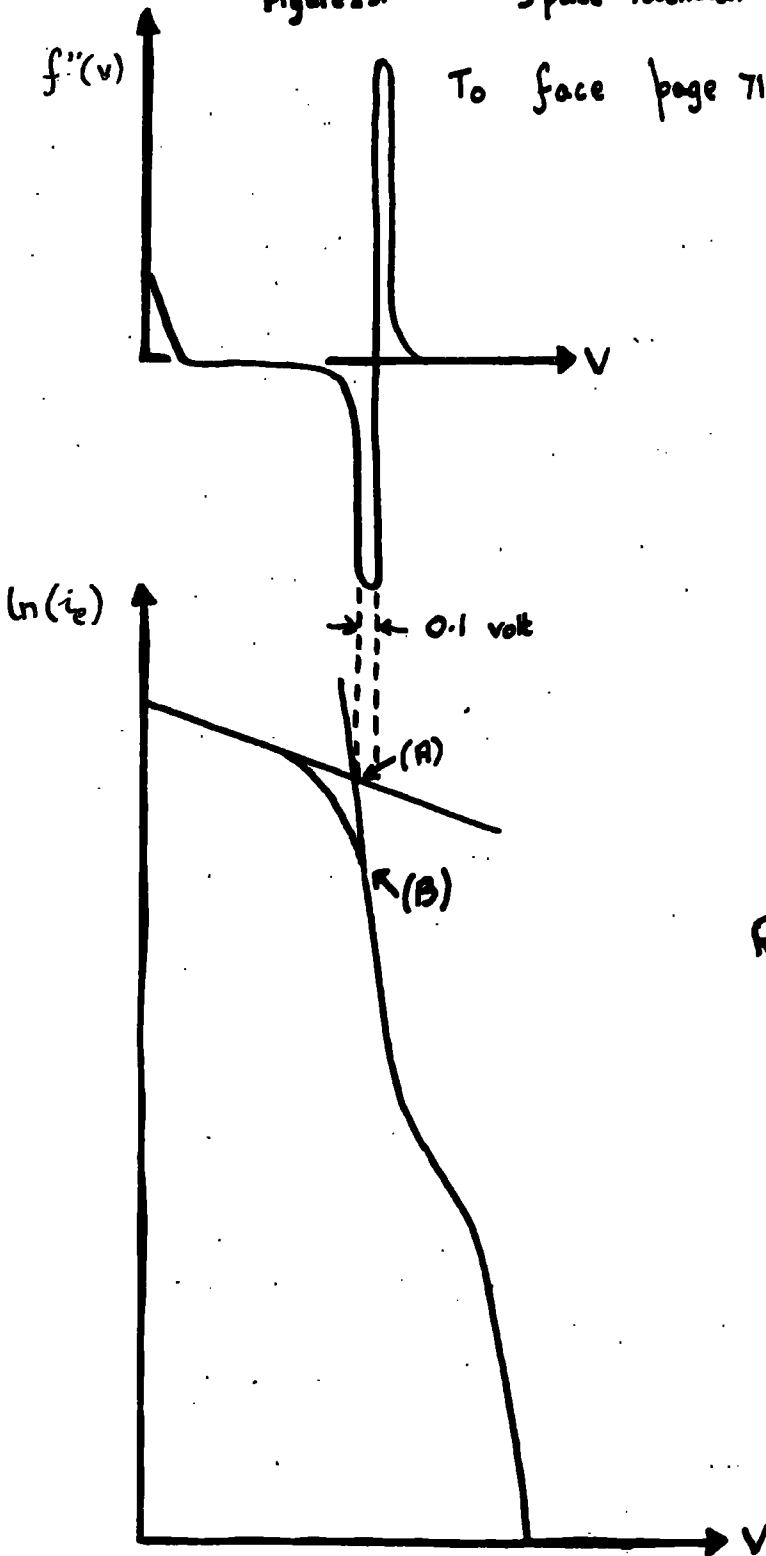

Reference: Boyd and Twiddy,
1959.

$$F(V_e) = V_e^{-1/2} f''(V) \quad (V \text{ is electron energy}) \dots \text{Equn. 39.}$$

This result was obtained by Druyvesteyn. This approach was used by Boyd and Twiddy (1954) to study the electron energy distribution in the striated hydrogen discharge, but the anisotropy of the velocity distribution reduced the precision of their results. Boyd and Twiddy (1959) criticise positive column theories which often assume a Maxwellian Distribution for electron energies in striated discharges.

In using the second derivative technique the effect of the positive ion current can be neglected, because, except when the probe is very near to the space potential, the second derivative of the electron current is much greater than the second derivative of the positive ion current. The Druyvesteyn analysis is applicable to all probe shapes only when the energy distribution is isotropic. A spherical probe must be used in the study of anisotropic distributions. A more sensitive test for a Maxwellian electron energy distribution than the linearity of the $\ln(j_e)$ against V plot is to plot $\ln f''(V)$ against V . This should be linear with a slope $1/V_e$, where V_e is a measure of the mean electron energy (in volts). If the logarithm of the second derivative plotted against V^2 is a straight line graph the distribution is said to be Druyvesteyn.

The space potential is not well defined because of the disturbance of the plasma when the probe is drawing large electron currents. This happens when it is near the space potential. There are two conventions for obtaining the space potential from the semi log plot (indicated by A and B in figure 25) and frequently there is not even a linear portion. The true space potential is more positive than the inflexion point on the current-voltage characteristic because of the disturbance caused by the probe. This disturbance depends on the ratio of probe diameter to tube diameter, to Debye length, and to electron mean free path.

The total electron concentration can be found by two methods. One method is to make a direct integration of the energy distribution curve.

The other method is to obtain the electron concentration from the random electron current to the probe at space potential, and a knowledge of the mean energy.

b. SHEATH FORMATION CRITERION.

Consider a point near a negative probe. Let $f(v_n)$ be the distribution function of the normal components of the velocity of the ions. Let μ' and μ'' be defined by:-

$$\mu' = n/n_e \quad \mu'' = v_e/v_-$$

For a sheath to exist at a point near a probe, the total space charge density must be positive. When this is so Boyd and Thompson (1959) have shown that:

$$\left(\int_0^{\infty} f(v_n) v_n^{-2} dv_n \right)^{-1} \text{ is greater than } \frac{e v_e}{n_+ v_e} \left(\frac{1 + \mu'}{1 + \mu' \mu''} \right)$$

from which it can be deduced that

$$\left(\frac{1}{2} \overline{v_n^2} \right)^{-1} \text{ is greater than } \frac{1}{2} v_e \left(\frac{1 + \mu'}{1 + \mu' \mu''} \right)$$

..... Equn. 40.

Ions of low energy are weighted in the average, so even a high ion temperature does not enable the sheath criterion to be satisfied by a one sided Maxwellian Distribution because of the large low energy contribution. Unless the criterion is satisfied the probe field will penetrate into the plasma and modify the energy distribution so that it is satisfied. Boyd (1954) considered that it was not then possible to say to what extent this field penetration would modify the more conventional interpretation of probe action as applied to rocket probes (which encounter an environment where the mean free path is long). In a laboratory discharge (where the electron temperature is much greater than the ion temperature) there are two important conclusions. Firstly, orbital motions of the ions need not be considered since at the sheath edge their velocities

Figure 26. Positive Ion Collection.

To face page 73.

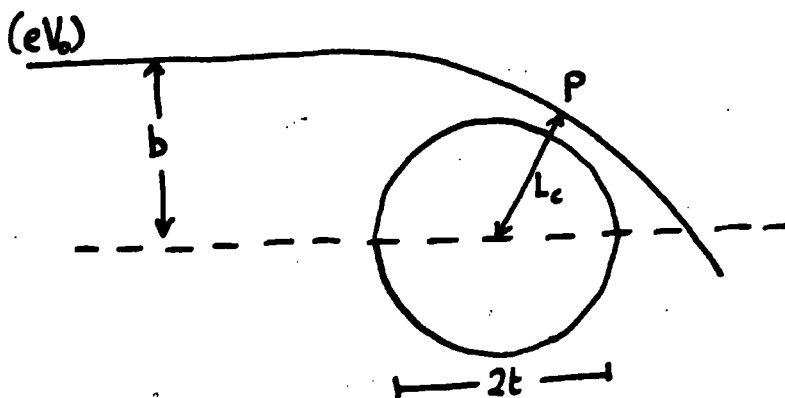
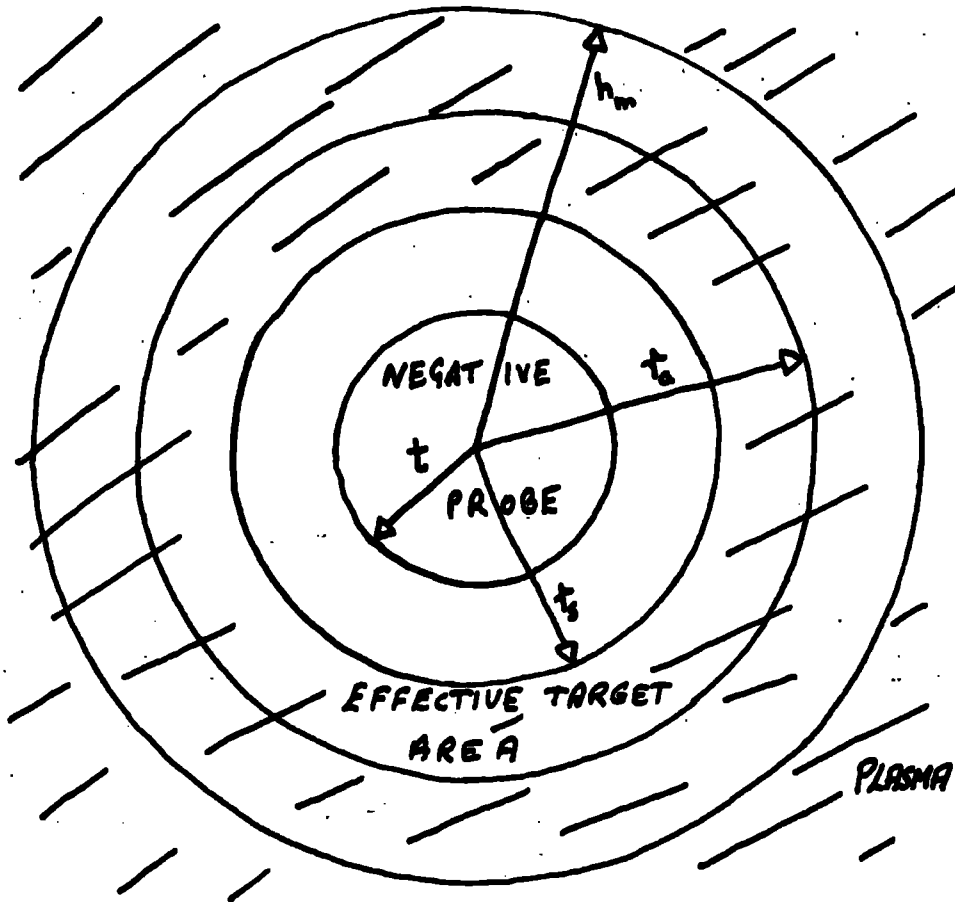

are almost wholly normal to the edge. Secondly, the flux of positive ions into the sheath is not $\frac{1}{4}n_+v_+$ but it is determined by the electron temperature. Consider for example the predicted ratio of saturation positive ion and electron currents for cylindrical and spherical probes in a running electropositive (positive ions present) discharge plasma. The classical saturation current ratio is given by:-

$$i_e/i_+ = (T_{em_+}/T_{m_e})^{1/2} \quad \dots \text{Equn. 41.}$$

The present ideas suggest that T_+ should be replaced by an "effective positive ion temperature" of $2.31 T_e$.

c. POSITIVE ION COLLECTION.

The modern concept of positive ion collection is that the ion current is determined mainly by the electric field which penetrates beyond the sheath edge. It is convenient to consider the low pressure plasma, where the usual conditions are an ion mean free path much greater than the probe dimensions, and an electron temperature much greater than the positive ion temperature. It has already been pointed out that the ion current depends on the electron temperature and not on the ion temperature, because the electron temperature determines the field strength which draws ions to the sheath. The validity of the conventional method of deducing the electron temperature by the retarding field method is unaffected by field penetration.

It is appropriate at this stage to introduce the idea of an absorption radius. This is defined so that within this radius from the centre of the probe all the ions move towards the probe and no ions hit the latter at grazing incidence. Mott Smith and Langmuir (1926) developed a theory which assumed orbital motions for the positive ions. Consider a negative probe as in figure 26. Do not assume that the electric field is restricted to the space charge sheath. At the distance of closest approach L_c to the probe, a positive ion has no radial velocity. Suppose that before the trajectory of the positive ion is modified by the probe, the

kinetic energy of the ion is eV_0 . If V_p is the negative potential at P, the kinetic energy of the ion at P is $e(V_0 - V_p)$. The equation representing the conservation of angular momentum then takes the form:-

$$bV_0^{\frac{1}{2}} = L_c (V_0 - V_p)^{\frac{1}{2}} \quad \dots\dots \text{Equn. 42.}$$

Ions hit the probe if $b = t(1 - V/V_0)^{\frac{1}{2}}$, where V is the probe potential and t is the probe radius. In figure 26 r_s is the sheath radius, r_a is the absorption radius and r_{min} is the radius of the effective target area.

No absorption radius exists if the potential distribution satisfies the condition that V_r/V is greater than $(t/r)^2$, where V_r is the potential at a radius r . This does not hold in a dense plasma.

We are now in a position to set out the scope of the different theories of positive ion collection.

The first case (A) to consider is when no absorption radius exists, outside the probe. Then, if the positive ion energy distribution is Maxwellian ($eV_0 = kT_+$), the Mott Smith and Langmuir (1926) theory may be applied:-

$$I_{+p} = A j_+ (4/\pi - 4V/\pi V_0)^{\frac{1}{2}} \quad \text{for a cylinder} \quad \dots\dots \text{Equn. 43a.}$$

$$I_{+p} = A j_+ (1 - V/V_0) \quad \text{for a sphere} \quad \dots\dots \text{Equn. 43b.}$$

where j_+ is the ion current density in the undisturbed plasma; I_{+p} is the positive ion current to the probe.

The second case (B) is when an absorption radius does exist, outside the probe. The theory to be applied then depends on the ratio r_s/t . If (1) $r_s = t$, and the ion energy distribution can be neglected ($eV_0/kT_+ \neq 0$), the Bohm, Burhop, Massey theory should be applied:-

$$I_{+p} = A \alpha_n (0.55?) (kT_+/m_+)^{\frac{1}{2}} \quad \dots\dots \text{Equn. 44a.}$$

Here the factor 0.55 is not strictly constant.

If (ii) $r_s = t$, and the ion energy is very much less than the electron energy, then the Allen, Boyd, Reynolds (1957) theory applies:-

$$I_{+p} = A n_e 0.61 (kT_e / m_+)^{1/2} \quad \dots \text{Equn. 44b.}$$

If (iii) r_s is greater than t , and the ion energy very much less than the electron energy, the equations are solved by numerical integration (see Allen, Boyd, Reynolds, 1957).

The positive ion temperature T_+ cannot be found from i_{+p} because the latter depends on T_e . However n_e can be found from i_{+p} instead of using the saturation electron current. This is better because small ion currents do not drain the plasma of charged particles. If the measured current is fairly constant as the probe becomes more negative, equation 44^b above should be used. If the positive ion current characteristic has an appreciable slope, the results of the numerical integration method should be used. For a low plasma density the sheath thickness is not negligible, and the probe-ion current grows as the sheath radius and probe potential increase.

Ionisation in the vicinity of the probe is neglected in this theory. This is valid for a sufficiently small probe.

The effect of ignoring the neutralising effect of the electrons which penetrate into the sheath edge is to contract the sheath by a factor $(1.7)^{1/2}$, and so to reduce the predicted current by $1/1.7$ (see Boyd and Thompson, 1959).

d. PRESENCE OF NEGATIVE IONS.

The sheath formation criterion may be used to derive the potential outside the sheath region surrounding a spherical probe immersed in an electronegative plasma (negative ions present). It is found that the potential falls to low values when the ratio of negative ions to electrons is greater than 2. Under these circumstances the positive ion current

collected is the random current across the sheath edge. If, however, the ratio is much less than two, then the collection of positive ions proceeds as for an electropositive gas. In a plasma in which there are no electrons, positive ion collection would depend on T_+ . Rocket borne Langmuir probes encounter weakly electronegative plasmas (n_-/n_e much less than two; V_e not greater than V_-). The method described by Boyd and Thompson (1959) may be used in studying the ion current.

—0—

APPENDIX TO CHAPTER 5.

THE MOVING HEMISPHERE CURRENT EQUATIONS.

The equations for the ion and electron current to a moving hemispherical collector, which have been developed and applied to predict the volt-ampere characteristics of a double-hemisphere probe by Hoegy and Brace (1961), are given in this appendix.

For a probe smaller than some lower limit (typically one or two millimeters), the ion current is limited by orbital motion. For a probe larger than some upper limit (typically several centimeters), the ion current is limited by the sheath area. (See section II).

Thus the magnitude of the sheath effect on the ion current depends primarily on the size of the probe in relation to the thickness of the sheath surrounding it. For example, the current to a very large collector (say of an extent greater than one meter) is due almost exclusively to the random motion of particles striking its surface, and the relatively small sheath (having a thickness of a few centimeters) does not significantly contribute to the current. Conversely, the ion current to a very small collector is greatly affected by sheath considerations (sheath size and potential).

The individual particle trajectories are essentially unaltered by the ^{magnetic} geomagnetic field while in the sheath. The potential induced across a probe due to its motion through the geomagnetic field is only a few millivolts at typical rocket velocities, and may be considered negligible.

The current equations are derived on the basis of the following assumptions:-

The negatively charged hemisphere is surrounded by a spherical positive ion sheath which is permeated by a radial electric field terminating at the sheath edge beyond which the velocity distribution of electrons and ions is Maxwellian. Inside the sheath, the electrons and ions do not interact, but move according to their initial velocities and the

Figure 27.

Moving Hemisphere Characteristic.

To face page 78.

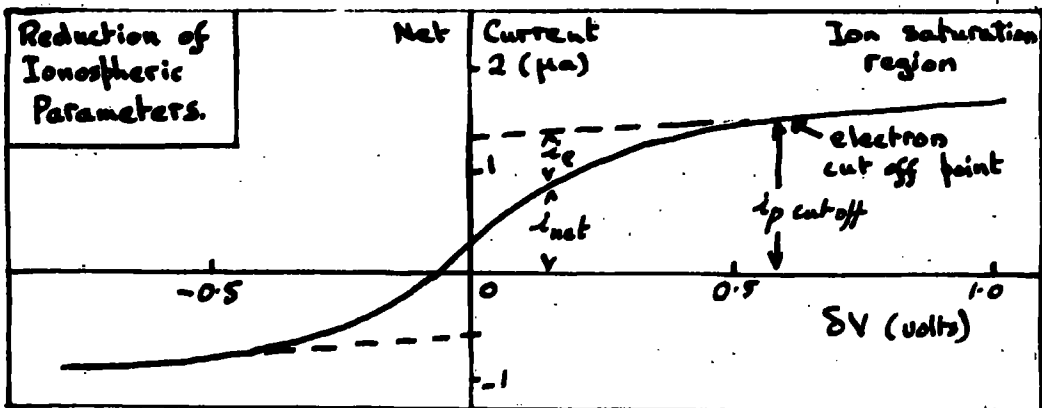
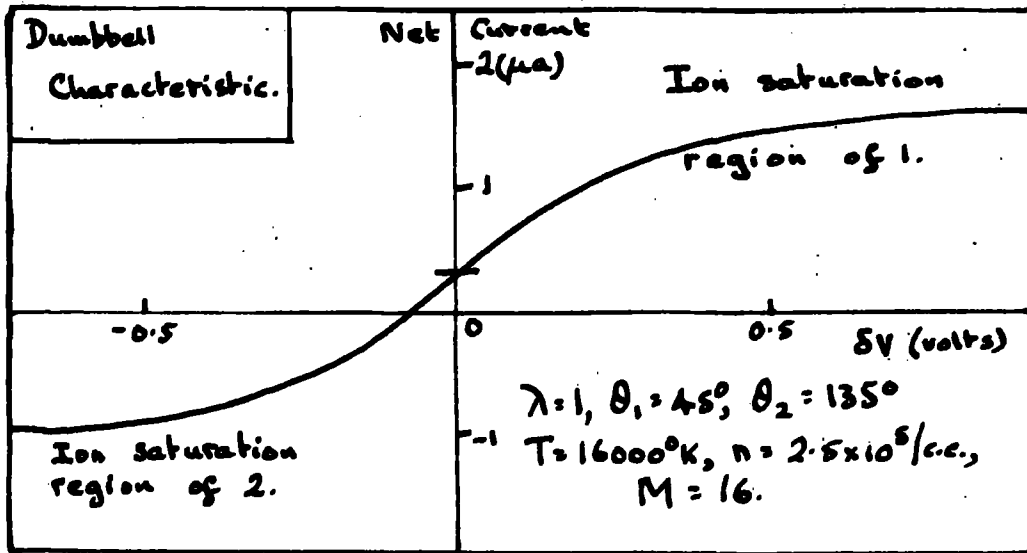
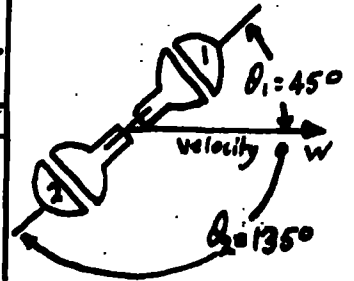
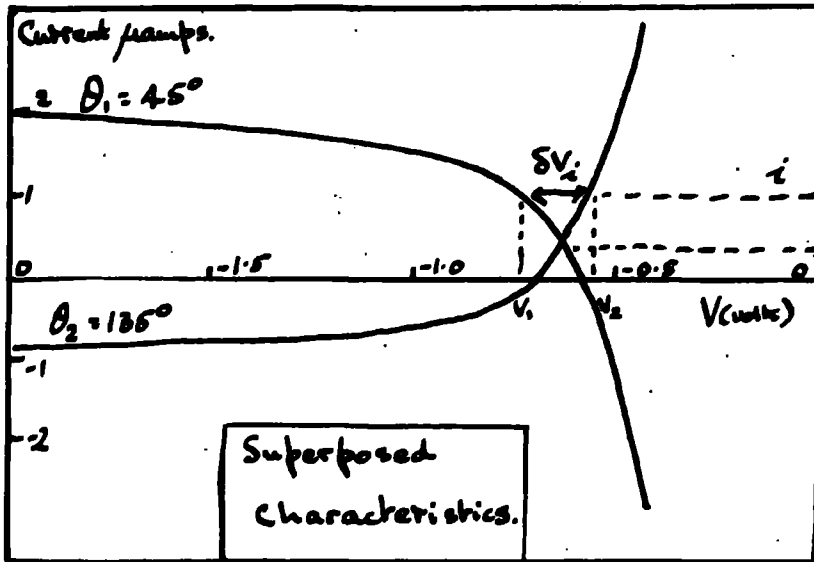

velocity they acquire from the local electric field. The probe moves through the plasma with a low relative drift velocity which is assumed not to alter the spherical symmetry of the sheath but serves only to modify the Maxwellian velocity distribution relative to the collector.

With these assumptions it can be shown that the random positive ion current density to an area element moving with a drift velocity relative to the plasma is given by:-

$$j_+ = \frac{n_+ e c_+}{2\pi^{1/2}} \left\{ \pi^{1/2} \lambda (1 + \operatorname{erf} \lambda) + \exp(-\lambda^2) \right\} \dots \text{Equn. 45.}$$

where λ is the normal component of the velocity of the element and $c_+^2 = 2kT_+/m_+$. The quantity in brackets represents the change in current density due to the probe motion.

The resulting random ion current to a hemisphere is found by integration.

For electrons, λ is nearly zero. In view of this, the electron current to a hemisphere is given by:-

$$\frac{n_e e c_e}{2\pi^{1/2}} 2\pi r^2 \exp\left(-\frac{eV}{kT}\right)$$

where r is the probe radius.

The net current to a single hemisphere can then be derived.

The positive ion current also depends on $V^{3/2}$ and a transcendental function of the sheath radius. Combining this with the expression for positive ion current which is obtained by the method above it is possible to eliminate the sheath radius and express the net current as a function of the voltage alone.

Figure 27 shows the superposed current characteristics so obtained for two oppositely oriented hemispheres, and the current-voltage characteristic of such a dumbbell arrangement, together with pertinent factors in the reduction of ionospheric parameters.

The assumptions made by Hoegy and Brace (1961) must be criticized in that they do not include the modern ideas on probe theory discussed in the latter part of chapter 5.

**A STUDY OF METHODS OF MEASUREMENT OF THE ELECTRIC CHARGE ON A ROCKET
AND OF AMBIENT ELECTRIC FIELDS USING PROBE TECHNIQUES.**

**SECTION 1. SURVEY OF LITERATURE
CHAPTER 6. ROCKET FLIGHT.**

	Page No.
MEASUREMENTS ON A ROCKET.	81
1. ROCKET EXPERIMENTS.	81
a. Some General Considerations.	81
b. U.S.A.F. Experiments.	82
c. Russian Experiments.	83
d. Michigan University Experiments.	84
e. Birmingham University Experiments.	86
f. University College (London) Experiments.	87
2. THE ROCKET LABORATORY.	89
a. Rocket Propulsion.	89
b. Rocket Trajectory.	91
c. Probe Location.	93
d. Nose Cone.	93
e. Apparatus Requirements.	94

CHAPTER 6. ROCKET FLIGHT.

MEASUREMENTS ON A ROCKET.

The work being carried out at other centres, and the ideas of the people concerned (e.g. Whitlock, 1960; Sayers and Court, 1961), have proved very illuminating. Information derived from letters, discussions and visits are included throughout this chapter, and their value is here collectively acknowledged. In addition, discussions within the department where this research was undertaken have provided the same sort of stimulus, and Dr J.A.Chalmers, Dr W.C.A.Hutchinson and Dr W.A.Prowse should be specifically mentioned in this context.

The previous chapters present a survey of the literature relating to various aspects of the work, and the next section describes the experimental work carried out under the guidance of Dr Hutchinson. But this chapter is concerned with what is really the core of the problem: "How does all the material available apply when one turns to the task in hand - the making of measurements on a rocket?"

The chapter is divided into two parts - rocket experiments, and a description of the rocket laboratory.

1. ROCKET EXPERIMENTS.

a. SOME GENERAL CONSIDERATIONS.

(i) A rocket is subject to certain hazards (Science News 48). For example X- and ultra-violet radiation destroy rubber and certain organic materials. Meteors destroy glass windows.

(ii) The temperatures on the nose cone or projecting parts of a rocket may, owing to air friction, reach several hundred degrees Kelvin on ascent (Boyd, 1959).

(iii) A rocket or satellite is subject to a drag (Berkner, 1958c) caused by (a) collision with neutral particles, and (b) the passage of a charged vehicle through an ionised medium. The mechanisms for charging

Figure 28. Probe Experiment (U.S.A.E).

To face page 82.

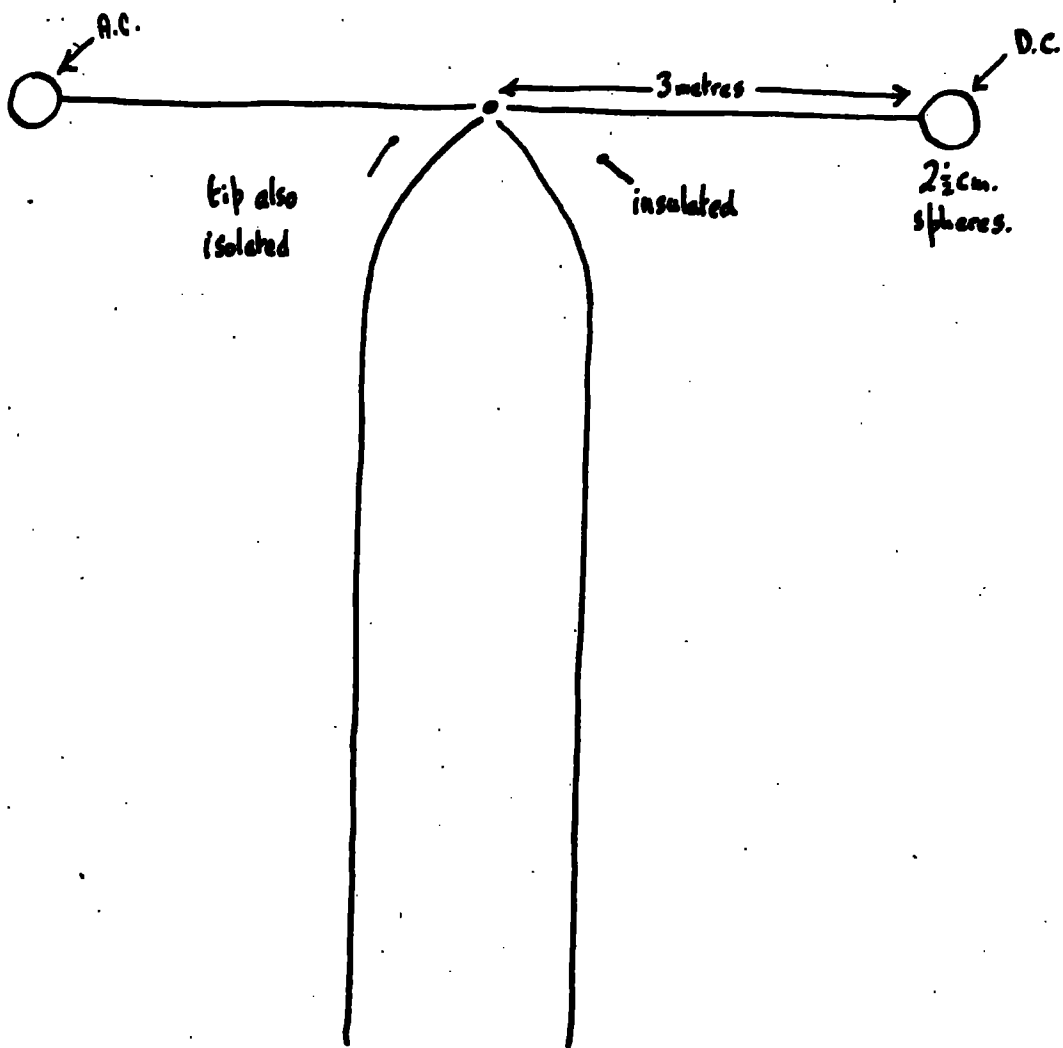

Reference: Smiddy, 1959.

are the high electron velocity and photoemission which have opposite effects to each other (Smiddy, 1959).

(iv) The source of ionospheric electrons may be taken (Berkner, 1958c) to be radiation from the solar corona at a black body temperature of 70 eV. The high energy tail of the electron velocity distribution is of the order of 60 eV. The fraction of the electron population at such high energies is of course small, the energy of a fast electron being quickly reduced by ionisation and electronic excitation until it reaches the threshold for the latter process (at 2 eV).

(v) An estimate (Berkner, 1958c) of the high energy electron population suggests that one electron in a thousand has an energy of the order of 60 eV. At these energies the random velocity ratio v_e/v_+ is of the order of 1000, and the flux of 60 eV electrons is equal to the positive ion flux. The time for energy degradation of a 60 eV electron is about 10 seconds, so this is the time in which the high energy electron population disappears when the sun sets.

(vi) In considering shielding theory, we must remember (Berkner, 1958c) that if the vehicle speed is much greater than the ion speed, then the ion distribution continually experienced by the vehicle does not have time to adjust itself.

6. U.S.A.F. EXPERIMENTS.

A rocket experiment has been designed using two probes (see figure 28) to measure vehicle charge and ambient field. A sensitive A.C. amplifier between a probe and the tip of the nose cone gives the external variation, while a D.C. amplifier between another probe and the tip gives the effect due to the rocket (Smiddy, 1959).

The D.C. amplifier has a time constant very much less than the rotation period of the rocket, while the A.C. amplifier is tuned to the rocket rotation frequency. The output from the D.C. amplifier is proportional to the vehicle potential with an added A.C. component proportional to the ambient field. Aspect sensing cameras allowed for the complexity of the

rocket motion.

The potential of the rocket relative to the surroundings was found to be between 0 and 10 volts. The effects of photoemission oppose the effects of electron capture. These are the main charging processes. Charged particles from the rocket in flight build up a potential but this is soon lost. Other results (Smiddy, 1960) show that the vehicle potential turns out to be of the order of -1 volt and the potential gradient of the order of 60 mv/metre. This is subject to correction because photo-emission from the probe surface will give the vehicle a positive potential with respect to the surroundings. An indication of this photo-emission potential is obtained by seeing what happens when the probe enters the rocket shadow. However the probe time constant is only 1/5 of the time in the shadow.

Re-entry data start at a height depending on the vehicle velocity - this height being higher for a fast vehicle, lower for a slow one - but in the region of 60 kms. Re-entry data are available from intercontinental ballistic missile shots. Telemetry transmission usually fails during re-entry and so these results are recorded in the vehicle and played back later. The chief characteristics of re-entry are the production of tremendous fields at the nose cone:- 5000 to 10,000 v/m.

Fields of the order of 200 v/m have been measured with field meters on a rocket. The field at the surface of a rocket must depend on the potential distribution within the unipolar charge sheath surrounding the rocket.

c. RUSSIAN EXPERIMENTS.

The vehicle charge was measured on Sputnik III (May 1958) and found to be negative and high. The earth's electrostatic field was 10 to 100 times the value which had previously been assumed.

It appears that the density of charged particles was found using Langmuir probes, and pairs of electrostatic voltmeters pointing in opposite directions made it possible to allow for the sheath field (Boyd, 1958).

Figure 29. Probe Experiment (Sputnik III).

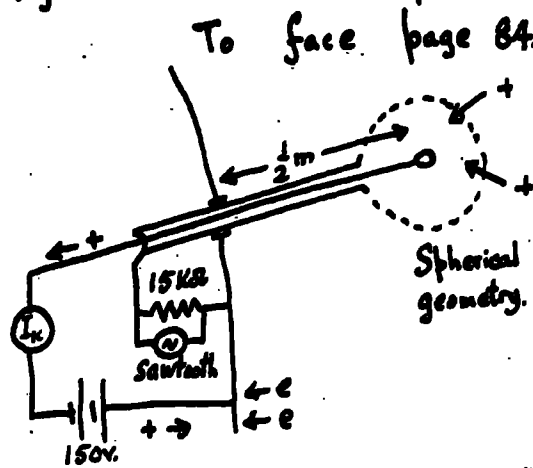

Figure 30. Time Characteristics (Sputnik III).

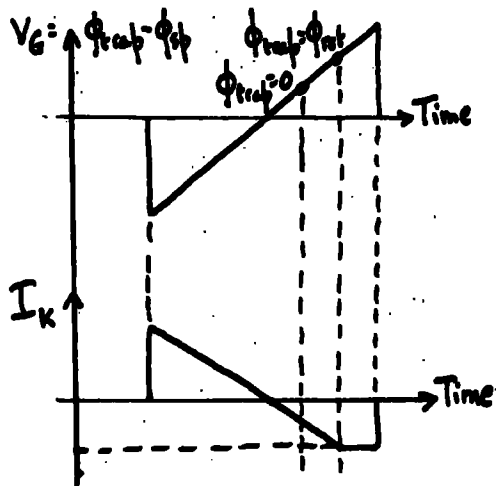
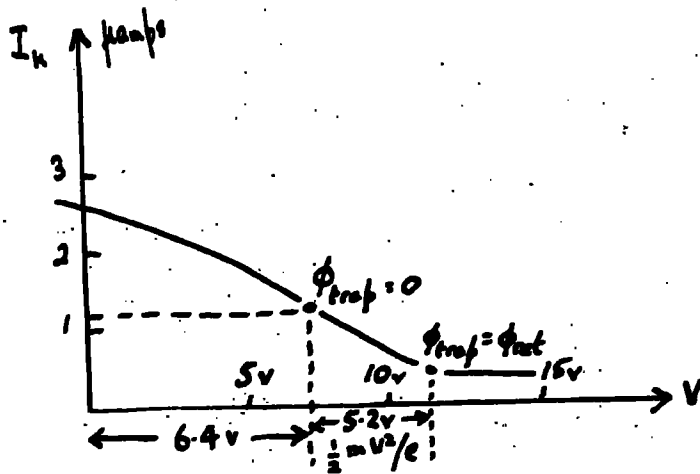

Figure 31. Probe Characteristic (Sputnik III).



Reference: Krassosky, 1959.

With the apparatus indicated (figure 29a), the sawtooth variation V_G permits the measurement of the vehicle potential relative to the plasma potential (Krassovsky, 1959).

Let ϕ_{trap} equal the voltage of the grid with respect to the surroundings, and let ϕ_{sp} equal the voltage of the vehicle with respect to the surroundings (figure 30b).

When $V = 0$, $\phi_{\text{trap}} = \phi_{\text{sp}}$. Now ϕ_{sp} is negative, and V must run positive before $\phi_{\text{trap}} = 0$. As V becomes more positive, it reaches the retarding potential for the collection of positive ions:-

$$e \phi_{\text{ret}} = \frac{1}{2} m V_s^2,$$

where m is the mass of the heaviest ions which are trapped, and V_s is the vehicle speed, which is very much greater than the average ion velocity. Typical results were obtained with voltage impulses every two seconds of 0.2 sec duration with the apparatus mounted on Sputnik III.

For $\phi_{\text{trap}} = 0$, the voltage is given by $V = 6.4$ volts, or in other words, $\phi_{\text{sp}} = -6.4$ volts (figure 30c).

The results published were:-

- 6.4 volts (i.e. $T_e = 15,000^\circ\text{K}$) at 795 km
- 2.0 volts (i.e. $T_e = 7,000^\circ\text{K}$) at 242 km

d. MICHIGAN UNIVERSITY EXPERIMENTS.

The University of Michigan have used a rocket-borne adaptation of a Langmuir probe to measure the properties of the E-layer of the ionosphere (Hok et al, 1953, 1954, 1958). Earlier attempts to use a rocket-borne probe were usually hampered by design concessions made for other experiments, considered primary, on the same rocket. The probe described, by Boggess (1959), was completely separated from the carrier vehicle and therefore no design compromises of this kind were necessary.

Figure 32.

Bipolar Probe (Michigan).

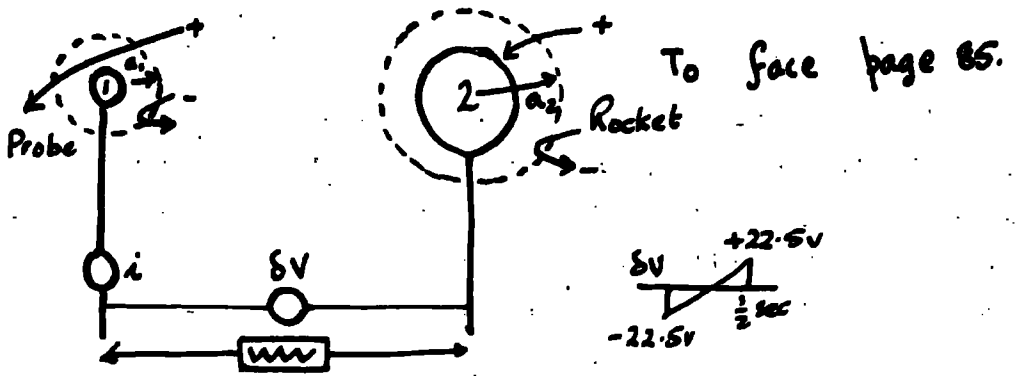

To face page 85.

Figure 33.

Bipolar Probe Potential Diagram.

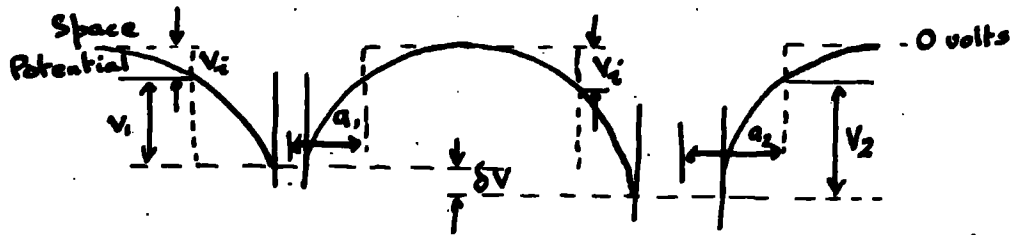

Figure 34.

Single Probe Characteristics.

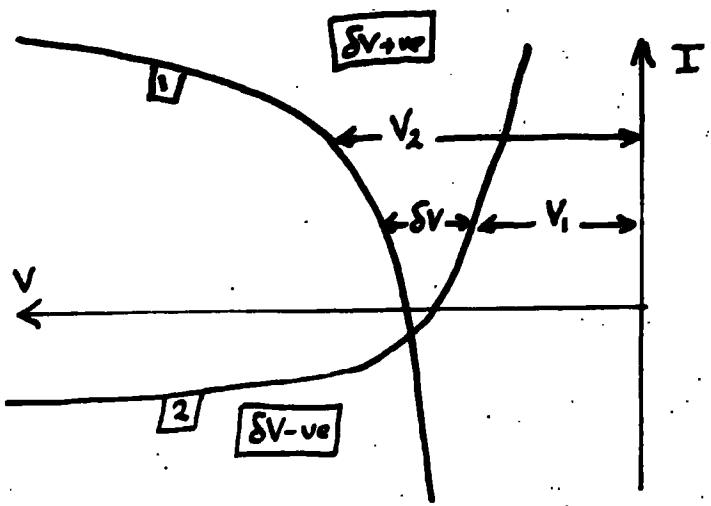
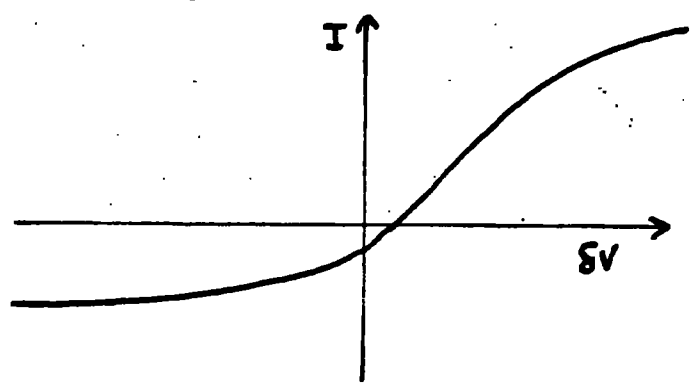

Figure 35.

Bipolar Probe Characteristic.



One particular bipolar design using two six inch spheres separated by a 10 inch long, $2\frac{1}{4}$ inch diameter cylinder was chosen. In this particular design the spheres were split and the outer hemispheres acted as information electrodes. The inner hemispheres acted as guard electrodes. The equal area double electrode probe causes the least disturbance of the plasma which is being measured.

Important accomplishments of the experiment were the first measurements of electron temperatures and ion number density in the altitude range between 112 km to 177 km, and the successful ejection of the probe in working order from a rocket moving at a high velocity.

The work is of interest because the simple arrangement of a rocket borne probe behaves as an unequal area bipolar probe system, the rocket itself behaving as a probe.

A schematic diagram of a bipolar probe is shown (figure 32) and (figure 33) the corresponding potential diagram is given.

The potential of each probe with respect to the space potential adjusts itself according to the current-voltage characteristic of the probe considered, and to the requirement that the currents to the probe are equal and opposite.

The single probe characteristics are shown (figure 34) and the resulting bipolar probe characteristic is given (figure 35).

It was assumed that outside the sheath there is a region of ambipolar diffusion which continuously replaces the ions and electrons collected by the probe from the sheath. The potential gradient in this region is small, but the concentration gradient of ions and electrons is appreciable.

It should be borne in mind that the modern probe theory holds that the presence of an electrode in the plasma is responsible for the ion current flowing to it by reason of its influence, as a boundary condition, on the potential distribution in the plasma. (See the introduction to chapter 5 on probe theory).

e. BIRMINGHAM UNIVERSITY EXPERIMENTS.

The Ionosphere has been successfully simulated (Dickinson and Sayers 1960) in a laboratory experiment designed to study ion charge exchange reactions in oxygen afterglows. In the decaying plasma, despite the absence of temporal equilibrium, thermal equilibrium obtains between ions and electrons. This situation is like that in the ionosphere and, moreover, it is possible to have particles of similar energies. These experiments have confirmed that dissociative recombination with molecular oxygen ions produced by a charge exchange reaction could be the primary electron loss process in the F2 layer.

If the electric vector of a wave is represented by $E = E_0 \sin 2\pi ft$, f being the frequency, then the alternating current to which this gives rise is represented by:- $I = (\epsilon_0 - n_e e^2 / m_e (2\pi f)^2) E_0 2\pi f \cos 2\pi ft$. For the experiment about to be discussed f is 10 Mc/s (which is not near the gyro-frequency (1Mc/s) and is much greater than the collision frequency). Thus the dielectric constant of a plasma is modified in a manner which depends on the electron concentration. So it has been possible to design apparatus to find the electron concentration by a measurement of the capacitance between two insulated plates at space potential. In an earlier form of this experiment (Sayers, 1959), the tip of the rocket was used as a probe and insulated from the nose cone. The variations in probe capacity were determined by using it to modulate the frequency of a local oscillator. Since the potential acquired by the rocket body was unknown the potential of the insulated cone with respect to the rocket was varied linearly - sawtooth waveform - providing an opportunity of identifying the condition that the nose cone is at local space potential (maximum measured electron concentration).

A mass spectrometer (Sayers, 1959) has been flown in which ions diffuse through an outer cylindrical grid and are accelerated by a known direct current voltage to an axial collecting rod. Pulses of ions are admitted to this stage by varying the grid potential and the ions are

Figure 36.

Probe Experiment (Skylark).

To face page 87.

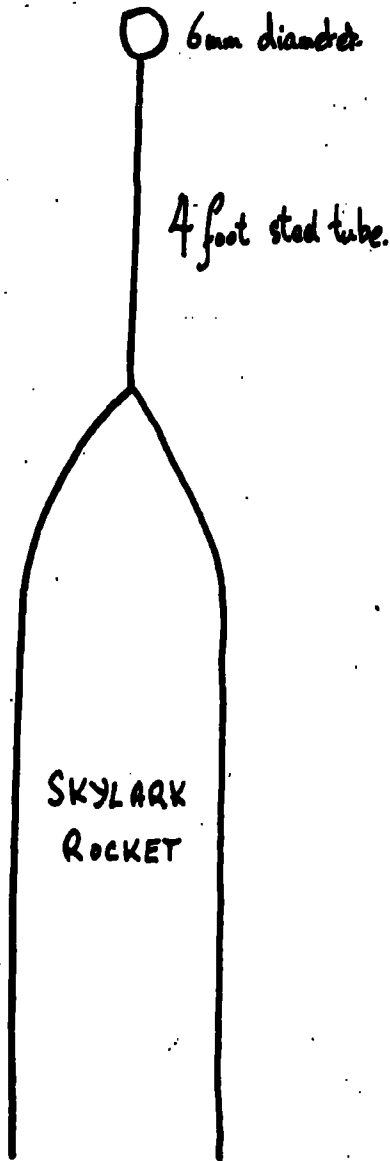

Configuration for Skylark Probe Experiments.

dispersed in time of arrival at the central collector according to their masses. In order to identify the space potential relative to the rocket a slowly varying "staircase" waveform was applied to the outer grid after the manner of the sawtooth waveform in the plasma dielectric method. Graphs of rocket potential relative to space potential plotted against altitude (up to 160 kms) show similar results to those obtained by Johnson and Hepner at Fort Churchill using Aerobees in 1958 (Sayers, 1960).

Apparatus designed at Birmingham and intended for rocket flight is tested in a large tank. The pressure in this tank can be reduced to 10^{-7} mm in half an hour. An A.C. or D.C. plasma is created in what is (comparatively) an extremely small side chamber and diffuses by an ambipolar process through a hole into the tank (Sayers and Court, 1961).

f. UNIVERSITY COLLEGE (LONDON) EXPERIMENTS.

The work at University College, London, has been described by Boyd (1954 to 1960). The laboratory simulation of upper atmospheric conditions is carried out by Boyd and his colleagues using a wind tunnel. This is a pressure wind tunnel designed to give jets with velocities of mach numbers 1 to 3 by expanding a superheated jet of mercury vapour. This jet stream is ionised by a radio frequency discharge.

The problems of using Langmuir probes in space have been discussed by Boyd in relation to a probe flown in the Skylark rocket (figure 36).

The problem is to make measurements from a gassy rocket during its transient encounter with the ionosphere.

In the ionosphere there is both thermal and temporal equilibrium, at any rate in the lower E and D regions, to a good approximation. Boyd has pointed out that a closely integrated experimental and theoretical research into the operation of probes in plasmas in thermal equilibrium in the laboratory would be most valuable.

In the laboratory, probe potentials are referred to an electrode. In

a rocket the potential of the system as a whole must adjust itself so that there is no net flow of current to the system. The probe current is limited by the flow of positive ions to the more negative electrode. Thus observations are only possible on the positive ion part of the characteristic.

Before any deductions are drawn from the positive ion part of a rocket probe/^{curve}very careful attention must be paid to the situation at the sheath edge. In particular the form of the positive ion velocity vector distribution must be taken into account.

The total area of zero or positive potential with respect to space must be a very small fraction of the missile area. The positive ion current collected by the rocket should be larger than the electron collection by the positive areas and thus permit the latter areas actually to assume zero or positive potential with respect to space.

It would greatly increase the possibility of reliable interpretation if it were possible to obtain probe curves giving the electron collection part of the characteristic up to saturation. Here the basic problem is to return to the ionosphere from the rocket a current equal to that collected by the probe. This might be done by means of thermionic emitters at some part of the rocket distant from the probe, or by creating at such a part an intense radiofrequency plasma such that the positive ion flux from the plasma to the rocket is ample to neutralise the electron flow to the probe.

The problem of returning the collected charge to the plasma through a low impedance path is not serious with a probe diameter of 6 mm, for which the probe area is very much less than the rocket area. Photo-emission and the collection of positive ions may be expected to give quite a low impedance between the rocket and the ionosphere. If the impedance is high, the voltage of the rocket is changed by the return of current.

Since it is difficult to clean the probe from oxide, and oxygen during flight a sufficient voltage must be applied so that the saturation current flows despite the voltage drop in a surface layer.

There are regions where the mean free path is neither large nor small compared with the probe (and rocket) dimensions, so that neither free motion nor diffusion approximations are valid. Ionisation densities are such that sheaths may be many centimetres thick. There are negative ions present.

The potential of the rocket depends on photoelectric emission and electrification by friction, as well as on the electrical state of the ionosphere. The effects of photo-emission from the probe and its structure may be allowed for by the use of two electrodes set into the surface of the probe - one sunlit and the other in the shade. The aspect of the rocket also controls the potential to some extent. (The photoelectric current is of the order of 10^{-5} amps/m²).

The supersonic vehicle velocity transforms the ion velocity distribution into one which is not isotropic.

In the D region the probe should be well ahead of the shock wave, and remote from the electrical influence or contamination from the rocket.

The second derivative of the function which represents the probe characteristic cannot be obtained from the telemetered signals but must be prepared electronically in the rocket itself.

2. THE ROCKET LABORATORY.

a. ROCKET PROPULSION.

Rocket propulsion (Sutton, 1956) is of interest from two standpoints - firstly, because we have to take the rocket trajectory into consideration; and secondly because we are interested in any possible contamination of the rocket surface.

In general the velocity attained by a rocket (v_r) is given by:-

$$v_r = v_e \log_e R \quad \dots \text{Equn. 46.}$$

where v_e is the exhaust velocity and $(R - 1) = \text{Mass of Fuel/Mass of Rocket}$. This formula neglects (i) the effects of the acceleration due to gravity

which are small if the combustion time is small, and (ii) air resistance, which reduces the velocity by about 10% (Science News 48).

Prior to launching (Berkner, 1958 a, b), the propellants are contained within their tanks by thin aluminium burst-diaphragms. At the instant of firing, high pressure helium is fed into the propellant tanks. The propellants, under pressure, rupture the diaphragms and flow into the thrust chamber where they ignite spontaneously. Valves prevent the contamination of the upper atmosphere by unused propellant.

The propulsion may be in two stages - for example the Aerobee is propelled by a "booster" which uses solid fuel and brings the velocity to 300 m/sec before the booster falls away, and by a "sustainer" which propels the rocket for 45 sec to a height of about 30 km and a velocity of 1.25 km/sec (Smiddy, 1959).

The propellant tanks contain the fuel and an oxidiser. In the Aerobee-H1 the oxidiser is red fuming nitric acid (6.5% excess oxides of nitrogen) and the fuel is a mixture of aniline and furfuryl alcohol. The oxidiser/fuel ratio is 2.58. Aniline is readily oxidised and at normal pressures it even undergoes aerial oxidation. The fuels have three main advantages - that of being readily available, a high density, and the property of self ignition (Neat, 1950).

With all the "High Altitude Sounding Rockets" (q.v.) of the USAF Space Flight Physics Laboratory, the thrust of the vehicle is terminated in the sensible atmosphere (i.e. at an altitude of 40 kms). Above this the vehicle is in a ballistic trajectory.

The thrust produced by the Aerobee-H1 booster is 18,000 lb x 2.5 sec, and by the sustainer 4100 lb x 50 sec at a specific impulse of 198 lb sec/lb.

EXOS is a rocket with three solid propellant stages - Honest John, Nike booster, and Recruit.

Figure 37. Rocket Velocity-Time Curves.

To face page 91.

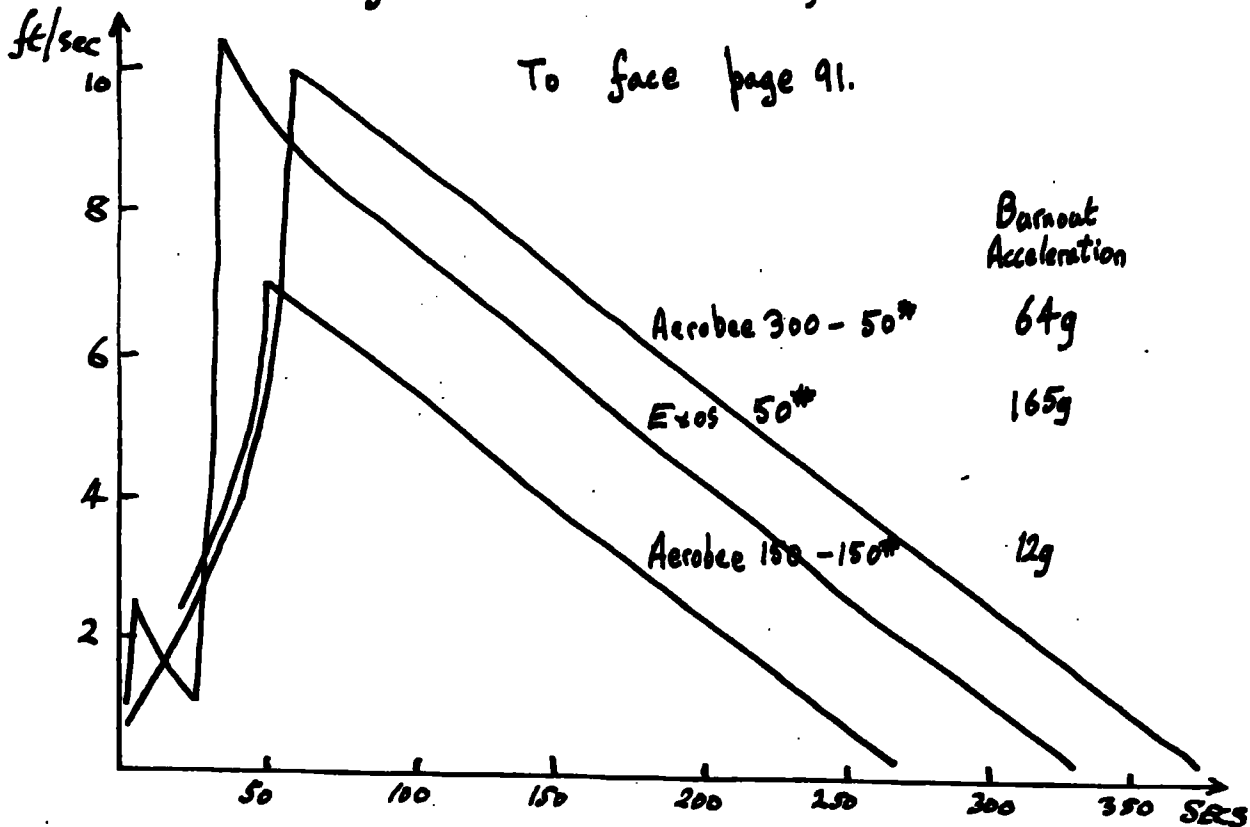

Figure 38. Maximum Rocket Altitude.

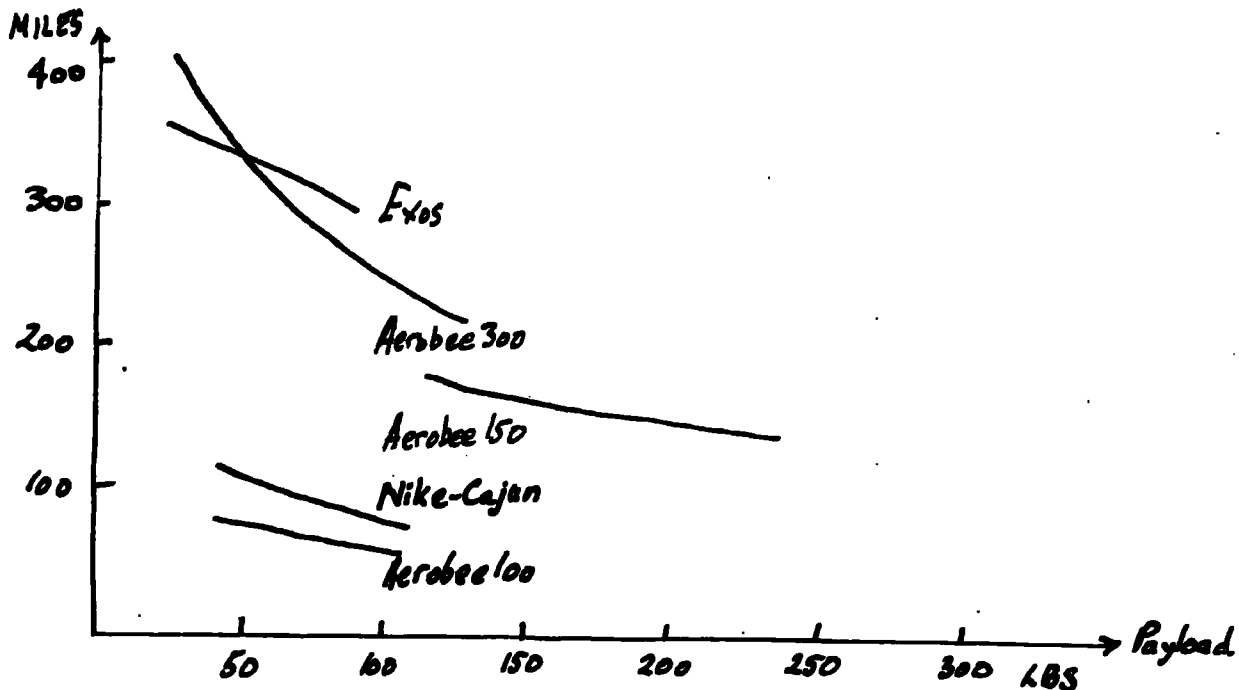

Figure 39.

Table for Trajectory Calculations - Free Fall

s	$(2s)^{\frac{1}{2}}$	$(2s)^{\frac{1}{2}} \times (g)^{\frac{1}{2}}$	$(2s)^{\frac{1}{2}} / (g)^{\frac{1}{2}}$	$a(2s)^{\frac{1}{2}}$
0	0			4.47
10	4.47		44.7 sec	1.85
20	6.32			1.43
30	7.75			1.19
40	8.94			1.06
50	10.00	1 km/sec		0.95
60	10.95			.88
70	11.83		118.3 sec	.82
80	12.65			.77
90	13.42			.72
100	14.14			.69
110	14.83			.66
120	15.49	1.5 km/sec		.64
130	16.13			.60
140	16.73		167.3 sec	.59
150	17.32			.57
160	17.89			.55
170	18.44			.53
180	18.97			.52
190	19.49			.51
200	20.00	2 km/sec	200 sec	.49
210	20.49			.49
220	20.98			.47
230	21.45			.46
240	21.91	2.2 km/sec		.45
250	22.36			

s = distance from peak of trajectory. g = acceleration due to gravity.

AEROBEE 300 - is a standard Aerobee 150 (with its solid booster) with a solid propellant engine, Sparrow, added. The Sparrow is fired immediately upon cessation of the Aerobee thrust. The nominal burn out time of the Aerobee is 52 sec. The Sparrow is a 1.8 sec burner.

AEROBEE 150 - is a booster assisted liquid propellant rocket which is tower launched. The nominal burning time is 52 sec. This rocket is also called the Aerobee H1.

(NOTE ON IONIC PROPULSION.

Ionic propulsion (Summerfield, 1961) for very fast space vehicles is a completely new technique. The thrust of an ion jet of 1 kW power leaving the nozzle at the relatively low speed of 10^7 m/sec is only 2g. But there exists no other method by which matter could be ejected at, say, ten times Sputnik speed. The development of high-power ion guns, with neutralisation of the ejected space-charge by electrons is a difficult problem, owing to certain inherent instabilities when ion and electron streams move together).

b. ROCKET TRAJECTORY.

The first graph (figure 37) shows the velocity-time curve for the "High Altitude Sounding Rockets" (q.v.) of the U.S.A.F. Space Flight Physics Laboratory. The thrust of the vehicle is in each case terminated in the sensible atmosphere, and after this the vehicle is in a ballistic trajectory. During this ballistic trajectory, the free fall equations may be used for a first approximation, and graphs may be constructed from the table (figure 39). The other graph (figure 38) shows the effect of payload on the altitude which can be obtained.

The Aerobee H1 has a maximum velocity of 2.2 km/sec and can attain a maximum altitude of 310 kms. We are interested in making measurements above about 100 kms, which is well above burnout height. The Aerobee trajectory is such that it lands 50 kms from take off point in a flight time of 15 minutes. To a first approximation, the rocket cuts through the region of interest vertically, once on the way up, once on the way down.

The dimensions and weights of the rocket and its payload vary according to the research tasks. Typically, the gross weight is 700 Kg

and the payload 70 Kg. The maximum payload is 90 Kg. Recovery of information is possible if a parachute is added in another section. The weight of this equipment is 36 Kg, so the maximum payload is then 54 Kg. The Aerobee H1 was produced in two versions (for the U.S. Navy and the U.S.A.F.) by the Aerojet-General Corporation, Azusa, California. (The Air Force rocket carries less propellant). This rocket can carry a 70 Kg payload to a height of 235 km from a launching elevation of 1.22 km and 230 km assuming a sea level launching. The payload includes the sensing element, the telemetry system, the supporting structure and the enveloping skin, estimates of these weights being obtainable from the U.S.A.F. space vehicle engineering section. The choice of rocket depends on payload requirements:-

- E.g. 23 Kg to 160 km Nike Cajun.
- 23 Kg to 480 km Exos Aerobee 300.
- 46 Kg to 100 km Aerobee 100.
- 69 Kg to 240 km Aerobee 150.

Included amongst extensions available are a 10" section, a 15" section, a nose recovery parachute, and a body recovery parachute extension. A limit of 30" of extension has been set on the basis of aerodynamic stability. The extensions are constructed of magnesium and the nose cone of spun aluminium.

The Aerobee has been described by Berkner (1958a, b); Smiddy (1959) and in Science News 48.

The elementary theory of projectile trajectories (figure 40) is presented in the form of a table (figure 39).

The trajectory, with the notation of figure 40 is given by:-

$$\phi = t v_{\max} \cos \gamma \quad \dots \text{Equn. 47a}$$

$$z = t v_{\max} \sin \gamma - \frac{1}{2} g t^2 \quad \dots \text{Equn. 47b}$$

c. PROBE LOCATION.

After burn-out of the fuel, and before the vehicle re-enters the dense atmosphere, it moves freely in the gravitational field. The motion of the rocket is determined by whatever linear and angular momenta it had when the external forces (rocket motor, steering jets, or aerodynamic forces) ceased or dwindled to insignificance. In general it may be assumed (Science News 48) that unless special steps are taken to stabilise it, any vehicle will rotate about its centre of gravity and at the same time execute a roll and precessional motion to a greater or less degree depending upon the components of angular momentum parallel to and normal to its major axis. In the case of a long cylindrical object like a rocket this means that in general the vehicle rolls (at a rate of about 1 r.p.s. for a medium-size rocket) about its length, and at the same time rotates much more slowly about some axis through its centre of gravity and at an angle to its length. This motion is not wholly undesirable. It provides a means by which sun-sensitive devices, for example, may simply and automatically be brought into a correct orientation for a short time during each revolution. Of course, the axes of rotation are fixed in space, and not relative to the flight path. A rocket that ascends nose first to its apex descends tail first until it enters the dense atmosphere again.

d. NOSE CONE.

Exos has a nose assembly which is 22.9 cm in diameter and 1.22 metres long, being cylindrical in shape with an attached cone. Instrumentation is affected by severe heating problems, and the diameter of all the apparatus must be less than 20.3 cm to give sufficient clearance.

The Aerobee 300 has a cylindrical payload section with a conical nose. The outside diameter is 20.3 cm and the length is 1.22 metres.

The Aerobee 150 payload section has a 38 cm base diameter and is about 2.2 metres long with a useful volume of 0.1 cubic metres. Standard 12.7 cms sections are available to increase the volume.

Figure 40. Simple Trajectory Equation.

To face page 94.

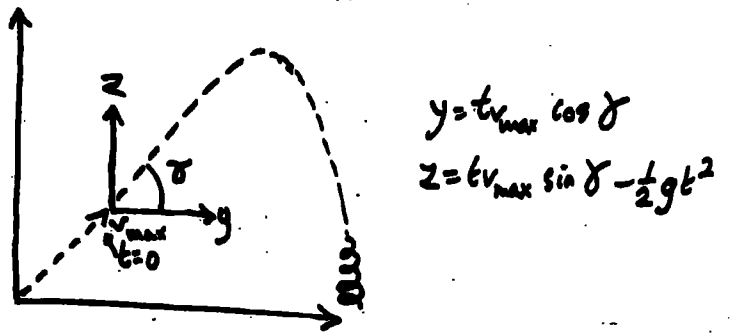

Author's diagram.

Figure 41. Aerobee-Hi Dimensions.

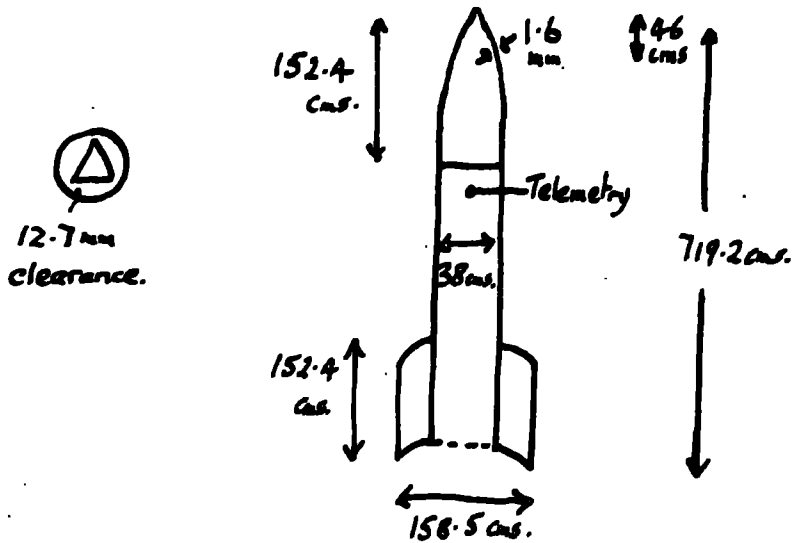

Reference: Smiddy, 1959.

The nose cone is constructed of spun aluminium and painted with heat resistant paint. Doors can be fitted, and in fact it is possible to cut a slot going the whole length of the nose cone. (See figure 41).

e. APPARATUS REQUIREMENTS.

The requirements for rocket apparatus have been described by Smiddy (1959). Cameras can be used to get aspect information but this will reduce the space. There must be a built-in calibration system. This will give "zero" when the telemetry is turned on. The zero should not be 0, and a suitable zero would be 1 volt. There are four telemetry channels. The 40 and 20 kc/s channels take 1000 cycle/sec variations, the 14 kc/sec channel responds up to 100 c/s, and the 7 kc/sec channel is 60 point commutated. Timing mechanisms must be included. A 28 volt D.C. power supply is available, and requires smoothing. The information is required in the form of a 0 - 5 volt signal.

PREFACE TO SECTION II

DESCRIPTION OF EXPERIMENTAL WORK.

During the two years of research the direction taken by the experimental work was changed many times, under the influence of discussions and increasing knowledge of the subject, which was a completely new one for the Department. Thus a chronological account of the work would scarcely be appropriate, the main value of the experimental work itself being the understanding it has given of some of the literature.

**A STUDY OF METHODS OF MEASUREMENT OF THE ELECTRIC CHARGE ON A ROCKET
AND OF AMBIENT ELECTRIC FIELDS USING PROBE TECHNIQUES.**

SECTION II. ACCOUNT OF EXPERIMENTS.

CHAPTER 7. VACUUM TECHNIQUE.

	Page No.
VACUUM TECHNIQUE - INTRODUCTION	97
1. THEORY OF VACUUM TECHNIQUE.	97
a. Units of Pressure.	97
b. Uses of Vacuum Technique.	97
c. Pumping Speeds.	97
d. Choice of Pump.	98
e. Air Ballast Rotary Pump.	98
f. Traps.	99
g. Outgassing.	99
2. VACUUM SYSTEM COMPONENTS.	100
a. Pump.	100
b. Mountings.	100
c. Manifold.	100
d. Valves.	100
e. Gauges.	101
f. High-frequency Leak-testers.	101
3. MATERIALS USED IN VACUUM WORK.	102
a. Oil.	102
b. Tubing.	102
c. Glass.	102
d. Seals.	103
e. Metal-Glass Seals.	103

Figure 42. Pump-Down Arrangement.

To face page 97.

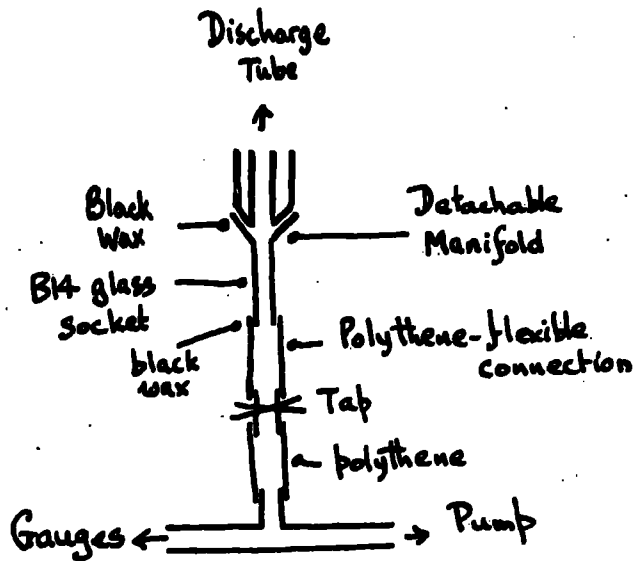

VACUUM TECHNIQUE - INTRODUCTION.

Vacuum technique was the most preoccupying part of the experiments. As this whole work is being written as an introduction to newcomers to the subject, the lessons learned here are put in a form which should make for easy reference for such a reader. Thus the rudiments of this subject are presented under three headings - theory of vacuum technique, vacuum system components, and materials used in vacuum work. The sources of information are Martin and Hill (1947), Edwards' (1961) Speedivac's Catalogues, and Braddick (1956).

The experimental arrangement used for pumping down the vacuum chamber is shown in figure 42.

1. THEORY OF VACUUM TECHNIQUE.

a. UNITS OF PRESSURE.

Some confusion exists over the units of pressure. British Standard 2951:1958 is a glossary of terms recommended for use in the high vacuum field. This standard lists the "torr" and its sub-multiple the "millitorr" as units of pressure, 760 torr being equal to 1 standard atmosphere. For all practical purposes therefore 1 torr = 1 mm Hg; 1 millitorr = 1 micron Hg. Throughout this work pressures have been expressed in mm.Hg.

b. USES OF VACUUM TECHNIQUE.

The main uses of vacuum technique are:- (i) to secure for atomic and molecular particles paths which are relatively free from collision, and (ii) to preserve surfaces relatively free from contamination.

c. PUMPING SPEEDS.

Pumping speeds are given by this relation:-

$$p = p_0 \exp(-St/v) \quad \dots \text{Equn. 48.}$$

where S is the pumping speed of the opening. At 300°K the value of S for air (per unit area of opening) is 11.7 litres per sec. The speed of any pumping system must always be less than the "hole" speed of the orifice presented to the vacuum chamber. In practice absorption or emission of

gas by the walls is important. A tubular connection offers resistance to molecular flow. The directions of particles bouncing off the wall have a random distribution, so only part of the incident gas passes along the tube. The pumping speed of a tube is less than the pumping speed of an orifice of the same radius. Pumping speeds of different sections may be added in series.

d. CHOICE OF PUMP.

The choice of a pump must be based on four considerations: (a) the size of the vacuum system, (b) the ultimate vacuum required, (c) the pumping time available, (d) the quantity and type of process gases and vapours. There are few vacuum systems without volatiles present and outgassing leaks, degassing and the presence of gases evolved during the process concerned almost invariably increase the size of the necessary pump.

Some pumps operate on the displacement principle. In rotary oil pumps the oil fills the dead spaces and so allows a high compression ratio to be obtained; it seals the moving piston against leaks, besides lubricating and cooling the pump. The pumping speed is low at low pressures. The final vacuum is chiefly limited by the dissolved gases and vapours which contaminate the oil.

Alternatively, pumps may operate on the diffusion principle. When the pressure has been reduced so that the mean free path of a molecule is of the order of a millimetre, it is possible to use pumps which depend directly on the kinetic behaviour of molecules. In diffusion pumps molecules entering the pumping region are swept away by a stream of vapour. Vapour diffusion pumps are used for the highest vacua. Vapour booster pumps are used for high speed pumping in the region where the displacement of other types of pump is rapidly falling. Residual gas in a system may combine with a "getter" to form compounds of low volatility.

e. AIR BALLAST ROTARY PUMPS.

In a rotary pump, when the moving rotor has compressed the trapped gas to slightly above atmospheric pressure, a discharge valve opens and the gas is blown out of the pump through a sealing oil bath. At low

permanent gas pressures condensable vapours are compressed to their saturation point before the discharge valve lifts, causing liquid to be ejected into the sealing oil. The liquid, which cannot escape from the pump, circulates with the oil and evaporates into the vacuum system, causing a deterioration in the ultimate pressure attainable as well as impairing the sealing and lubricating properties of the oil. The air ballast method consists of introducing air at atmospheric pressure through a one-way valve into the volume between the moving blade and the discharge valve while it is still at a comparatively low pressure. When this volume is compressed prior to expulsion the discharge valve lifts before the partial pressure of the vapour component is sufficient to cause condensation.

f. TRAPS.

Single stage rotary pumps will produce a vacuum of 0.005 mm.Hg. The vapour pressure of water is 12 mm.Hg. Water will also contaminate the pump oil. For these reasons a desiccant must be used. The ultimate vacuum obtained from a mercury vapour pump, assuming the design to be satisfactory, is limited by the presence of mercury vapour. At 20°C the vapour pressure of mercury is 1.2×10^{-3} mm.Hg. A refrigerated trap is placed between the pump and the vacuum system for work at lower pressures.

g. OUTGASSING.

Glass and metals hold large quantities of gas both in solution and as adsorbed surface layers. Adsorbed gas may be removed from glass by heating to 300°C. In practice, during the baking out of a glass vacuum system, the temperature is maintained as closely as possible to the annealing temperature. Metals may be outgassed by heating in vacuo to temperatures somewhat below the fusion point. Since the outgassing process is principally one of gas diffusion the temperature of the metal should be as high as possible. Electroplated surfaces are good provided they are unbroken, but cracked surfaces are too often prolific sources of gas.

2. VACUUM SYSTEM COMPONENTS.

a. PUMP.

The pump used by the author was an Edwards' 2SC50 two-stage gas ballast rotary high vacuum pump. It can obtain an ultimate vacuum without ballast of 0.0002 mm.Hg; with full ballast, 0.0003 mm.Hg. These pressures are measured by a McLeod gauge since the pump oil has a vapour pressure which may be greater than that of the permanent gases in an evacuated system. The pump has a displacement of 48 litres per minute, and is driven by a 1/3 h.p. motor.

b. MOUNTINGS.

The pump stands on anti-vibration mountings, each one consisting of two "U"-shaped metal pieces separated by rubber bondings.

c. MANIFOLD.

The manifold (Edwards' type 5A) fits immediately above the non-return valve at the pump inlet. When filled with phosphorus pentoxide, it is suitable for use as a moisture trap. In the presence of excess desiccant, the approximate water vapour pressure is 1.8×10^{-5} mm.Hg. When filling the manifold, the surface is left rough, and furrows are drawn across it to increase the exposed surface area. Air is admitted slowly to avoid blowing the desiccant out of the trays.

d. VALVES.

An Edwards' "Speedivalve" was used. These are designed so that all moving parts are isolated from the vacuum system which is sealed by an elastomer diaphragm. When open the valve gives full pipe area with clean flow lines to obviate throttling effects. The Edwards' Non-return valve, mounted on the inlet flange of the pump, did not prove satisfactory. Air must always be admitted to rotary vacuum pumps before they are stopped, otherwise the pump oil will be forced into the vacuum system. Edwards' air admittance valves were used. One was a type OSIC vacuum sealed needle valve having a dependable spindle seal, and a dial pointer that can be

zero adjusted. The other was a type RS1A brass air-admittance valve with vacuum isolation given by a rubber-nosed spindle, which is prevented from rotating during operation.

The pump was run continuously and the pressure controlled by using the air admittance valves as adjustable leaks, by using the speedivalve as a throttle, by inserting extra air reservoirs, by suitable ballast settings, or by relying on ultimate equilibrium.

e. GAUGES.

The thermal gauge (Edwards' Pirani type B2) operates by the change in temperature - and hence resistance - of an electrically heated filament as the heat conductivity of the surrounding gas changes with pressure. The resistance change is measured on a meter as the out-of-balance current of a Wheatstone bridge network. The gauge gives continuous readings and indicates total pressure, but is gas dependent.

The McLeod gauge depends on a direct application of Boyle's Law. The trapping and compression of the vacuum system gas is arranged for by raising a reservoir so that mercury rises into the gauge head. In the "Vacustat" the same effect is obtained by gravity, the reservoir being raised by revolving the complete gauge head. These compression gauges condense out system vapours and indicate partial pressures. They indicate a lower pressure than the Pirani gauge. Readings cannot be taken continuously. The pressure indicated does not depend on the gas.

f. HIGH-FREQUENCY LEAK-TESTERS.

A control varies the distance between contacts which are coupled through condensers to feed a Tesla coil connected to a probe. They will give a glow discharge in gases at pressures between 1 and 0.1 mm.Hg. They cannot be used near an electrode seal. It is possible to find a leak by obtaining a pink discharge. The suspected areas are painted with acetone, alcohol or ether and if there is a leak, the colour of the glow discharge will change from pink to pale blue. These solvents may of course dissolve the jointing compounds used in the system.



3. MATERIALS USED IN VACUUM WORK.

a. OIL.

The oil used in the 2SC50 pump was not the mineral oil recommended for rotary vacuum pumps without the air ballast facility, but an additive-type oil. These oils are blended with multi-functional additives selected for minimum volatility so that they will not be distilled out of the oil or significantly contribute to the oil vapour pressure. Edwards' Grade 17 was used at first, and later grade 18, which is of heavier viscosity. The oil in the interior of a mechanical high vacuum pump may be subject to contamination by condensed or dissolved vapours or gases from the vacuum system being pumped. Air ballast is usually sufficient to remove condensable vapours.

b. TUBING.

When tubing made from rubber or plastics is used in a vacuum system at pressures below 1 mm.Hg., it tends to 'outgas', i.e. to emit vapours which raise the pressure, just as if there were a leak in the system. Measurements have been made of the outgassing rates, under various conditions, of samples including neoprene and polythene tubing. Polythene was found to be one of the most satisfactory materials and neoprene the least satisfactory. (Hayward, 1960).

Flexible tubing of large diameter was supported by helices of enamelled copper wires as part of the experimental system.

c. GLASS.

Glass is an excellent vacuum material - it can be cleaned, outgassed in situ, and sealed together without waxes; leaks are readily located and rectified; and pumped systems can easily be sealed off. Borosilicate glass (Pyrex type) has an annealing temperature of 560°C. Glass is at a disadvantage in systems subject to strain, and polythene links may be used. Polythene tubing remains firmly fixed to any material onto which it can be tightly pushed.

d. SEALS.

Black Picien wax adheres well to glass and metal. It is sufficiently yielding at 15°C to avoid cracking in use. It flows freely at about 80°C.

The soft grade of vacuum grease flows freely at about 40°C and is suitable as a lubricant for stopcocks. The hard grade flows freely at about 50°C. It is used for sealing conical and flat joints of glass or metal. A well lubricated stopcock free from streaks may be easily prepared by applying two lines of grease down the length of the warmed plug furthest from the bore. The plug is then pressed into position without rotation until all the air is expelled.

Araldite XS3/11 adhesive is a cold-setting flexible material suitable for bonding materials with different coefficients of expansion. The adhesive consists of two solvent free components: a medium-viscosity liquid resin, and a low-viscosity liquid hardner.

'O'-ring containing members may be used to make a pipe connection to any apparatus face that is machined to a reasonably flat surface.

e. METAL-GLASS SEALS.

The earliest seals were made in ancient Babylon by the goldsmiths who fused a vitreous glaze on to gold to form enamelled ornaments. Discs of glass may be sealed to metal rods. It is not practicable to seal pyrex to copper on a seal of this type, but tungsten to pyrex seals can be obtained from various lamp works.

Figure 43. Main Features of Apparatus.

To face page 104.

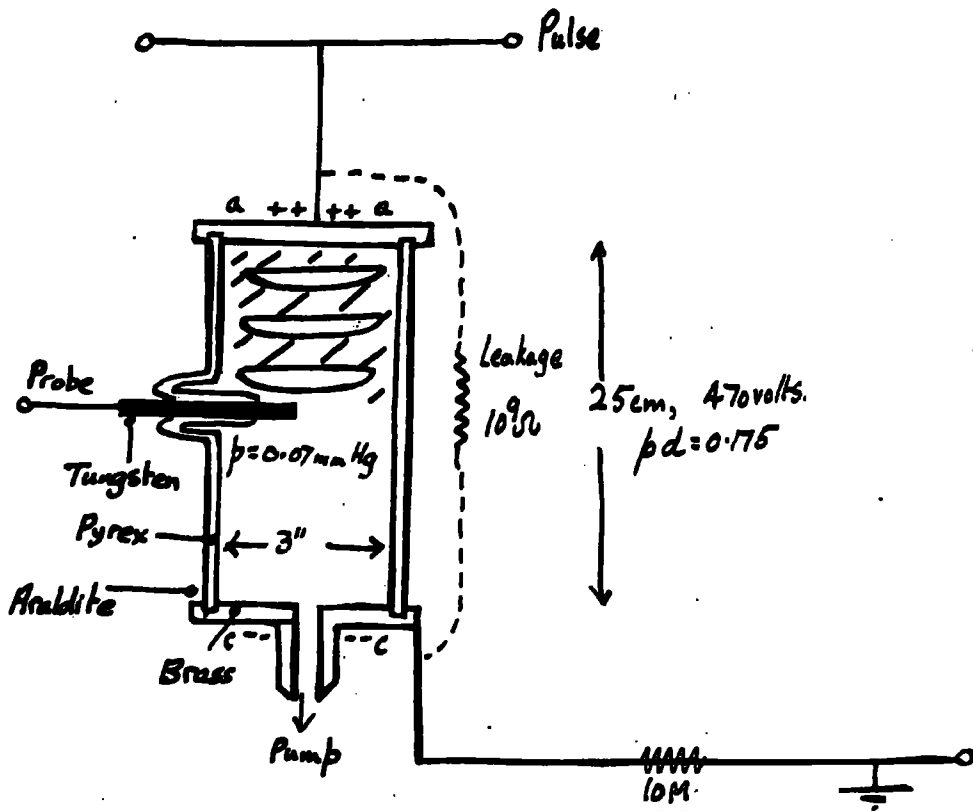

Figure 44. Power Supply Circuit.

To face page 104.

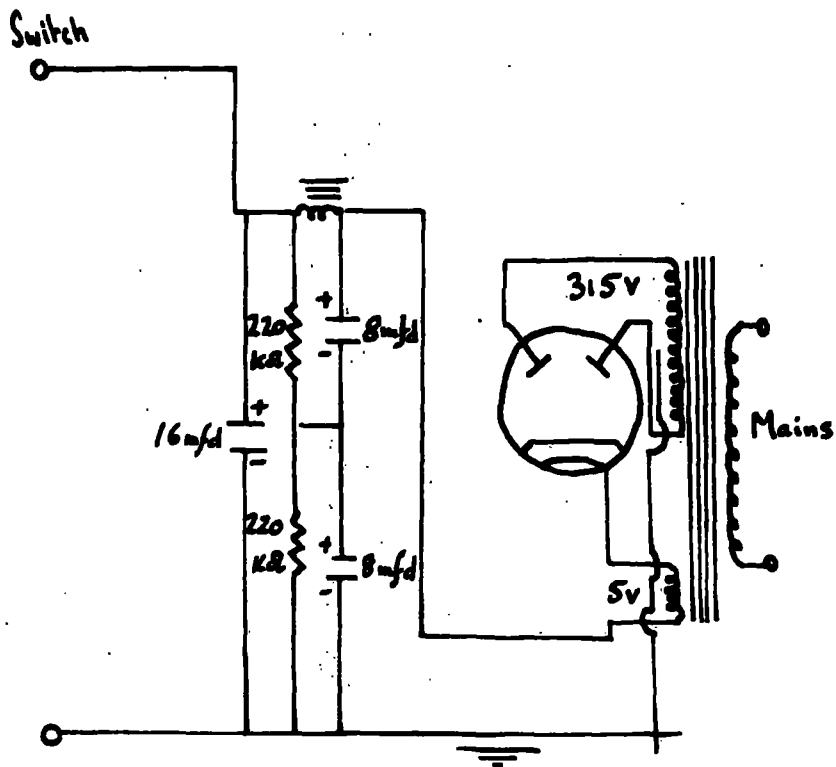
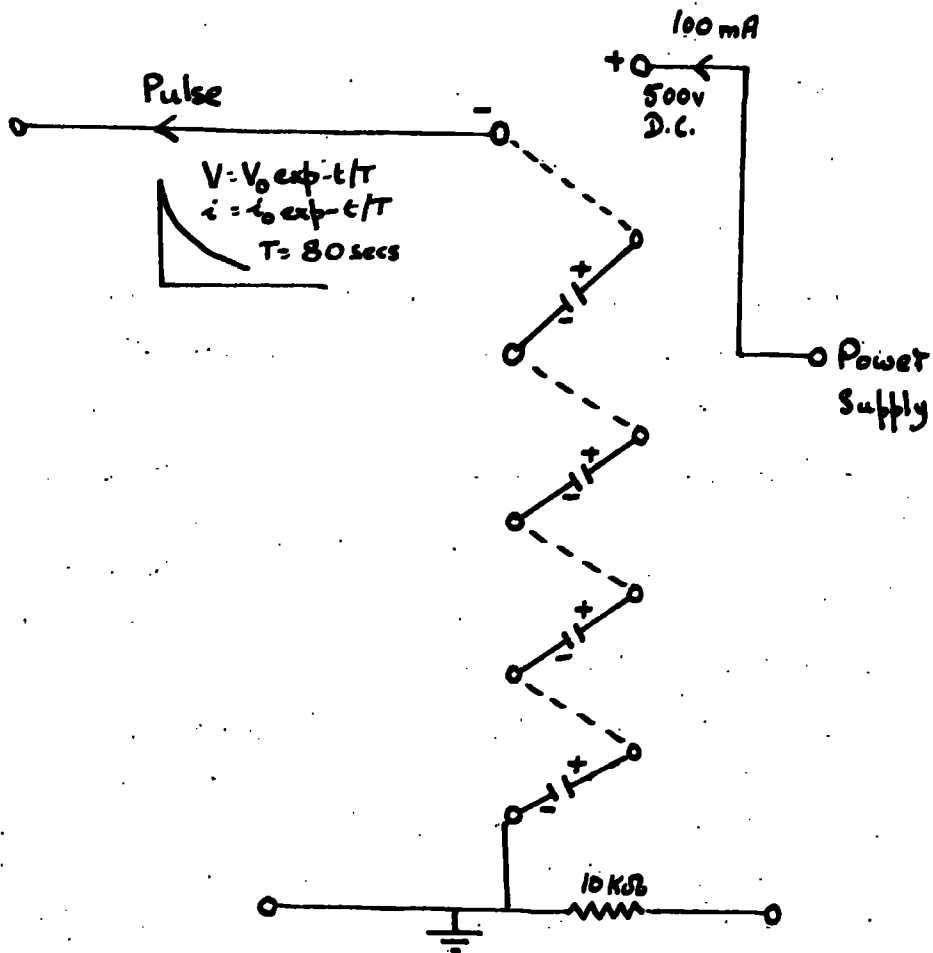

Figure 45. Switching Circuit.

To face page 104.



The condensers are 32 μF , 500 volt electrolytics.

**A STUDY OF METHODS OF MEASUREMENT OF THE ELECTRIC CHARGE ON A ROCKET
AND OF AMBIENT ELECTRIC FIELDS USING PROBE TECHNIQUES.**

SECTION II. ACCOUNT OF EXPERIMENTS.

CHAPTER 8. EXPERIMENTAL SYSTEM.

	Page No.
Introduction	
a. Description of Apparatus.	104
b. Qualitative Results.	104
c. Nature of Striations.	105

INTRODUCTION.

The apparatus used for performing experimental work is described and qualitative results presented, including a probe characteristic.

a. DESCRIPTION OF APPARATUS.

The main features of the apparatus which was constructed are shown in figure 43. The gas in a fairly large discharge tube was pumped down to 0.07 mm.Hg. pressure. A large tube was chosen so that the probe should be small relative to the volume of the plasma. The power supply was obtained with the circuit shown in figure 44.

A pulse was obtained from a circuit with a time constant of 80 seconds and was used to break down the air in the tube. This pulse was obtained from a bank of electrolytic condensers, which were charged in parallel and discharged in series. The electrolytic condensers were kept on charge for days before making a series of experiments as this increases their leakage resistance. The charge/discharge switch (figure 45) was of the mercury in wax type, with a polystyrene key with brass foil contacts.

b. QUALITATIVE RESULTS.

The direct current discharge has been discussed in chapter 2. A very

Figure 46. Measuring Circuit.

To face page 105.

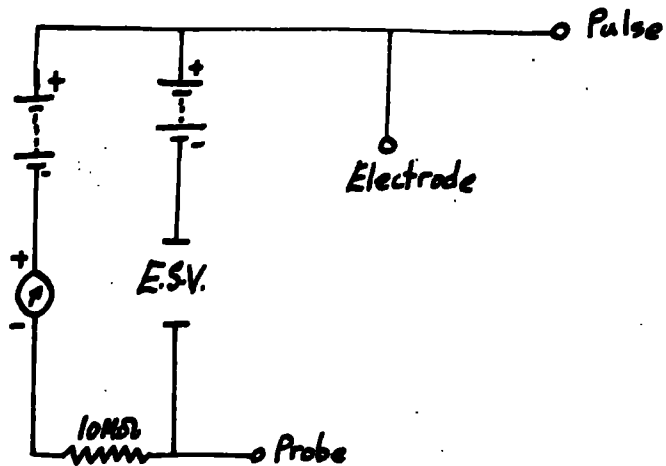

The Electrostatic Voltmeter (E.S.V.) was found to be accurate over a range 50 to 70 volts.

Figure 47. Cylindrical Probe Characteristic.

To face page 105.

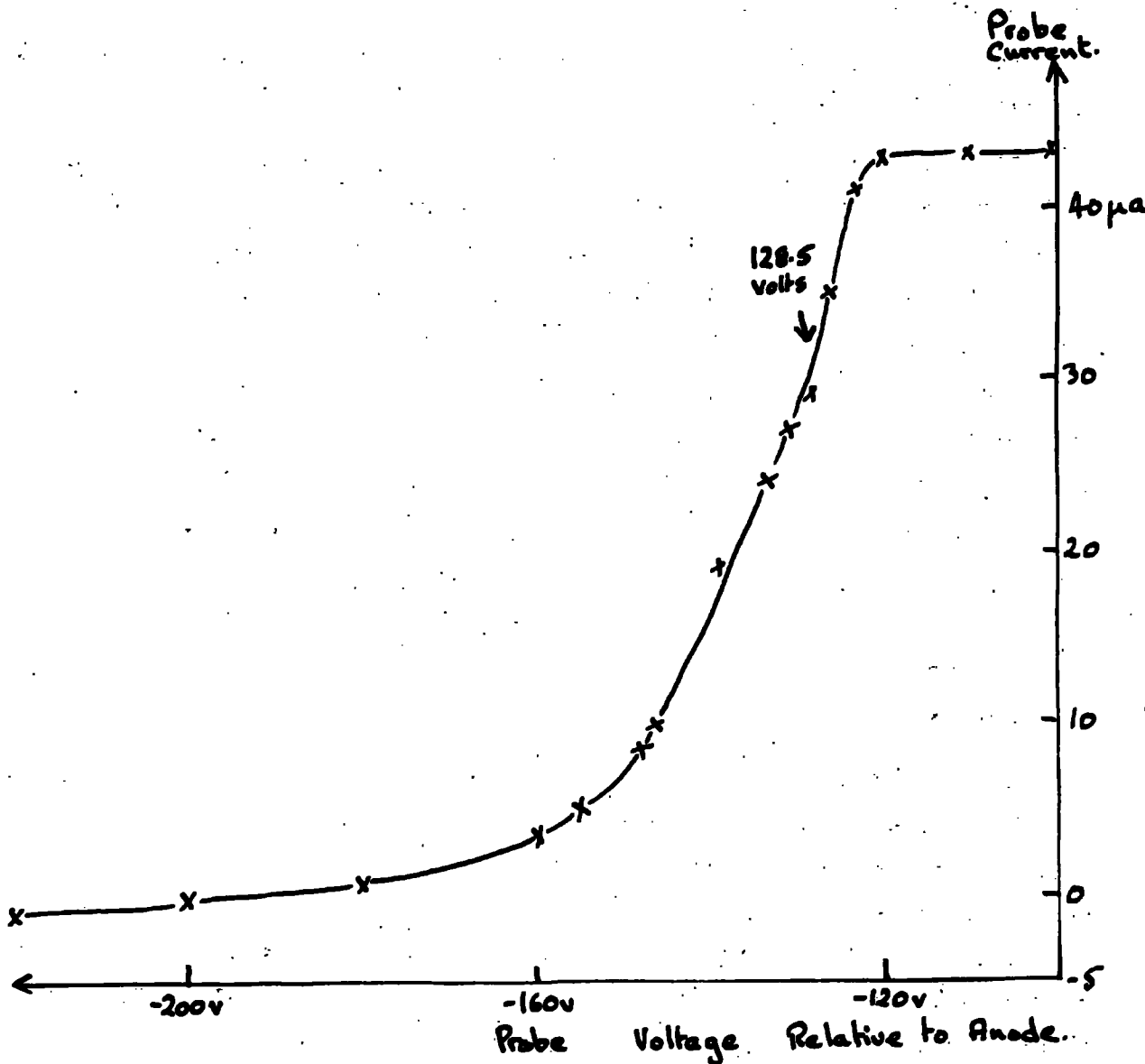

The derivation of 128.5 volts as the space potential is discussed on page 109.

steady discharge was obtained, which sustained a potential difference of 470 volts between the electrodes. With a 25 cm. gap between the electrodes, this means that $pd = 0.175$ in the units given on figure 4, page 29. Thus the operating point (X, in figure 4) is just on the low pressure side of the Paschen curve minimum.

The leakage resistance of the whole tube was 10^9 ohms, which is obviously sufficiently high.

The main experimental problem was to find steady conditions, and a discharge which filled the diameter of the tube. This meant suitably adjusting the pulse and vacuum systems simultaneously. Measurements were made with the circuit of figure 46 at the edge of the striations in a discharge which took the form of three extremely stable striations.

Outside the stable region the pulsed discharge behaves in a most complex manner, which suggests it might be interesting to study, but this has no bearing on probe technique.

Attempts to obtain characteristics with a screened cylindrical probe (tacitron) were inconclusive as steady conditions were not obtained. However, a probe characteristic was obtained (figure 47) for a cylindrical tungsten probe.

c. NATURE OF STRIATIONS.

The problems encountered in finding steady conditions aroused interest in the physical nature of discharge striations. The nature of the striations has been interpreted by Pekarek and Krejci (1961) on the basis of the production of a periodic structure in a plasma after an aperiodic disturbance. The wave of stratification in a plasma is phenomenologically most similar to the development of the well-known wave pattern on a water level after an aperiodic disturbance, e.g. after throwing a stone into water. The following three phenomena seem to be the most important for the physical mechanism of the production of striations: (a) the dependence of the rate of ionisation on the electron temperature and hence on the electric field, (b) the production of space charges due to the different rates of diffusion

Figure 48. Production of Striations.

To face page 106.

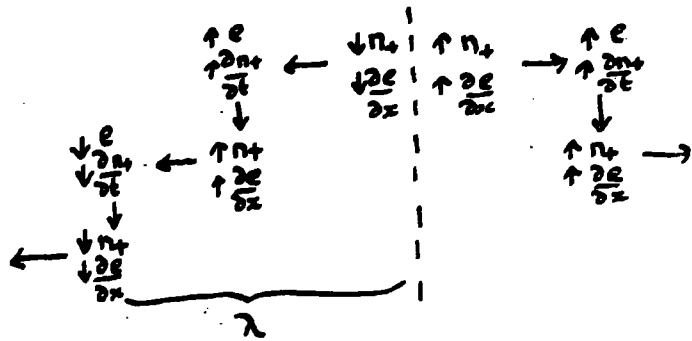
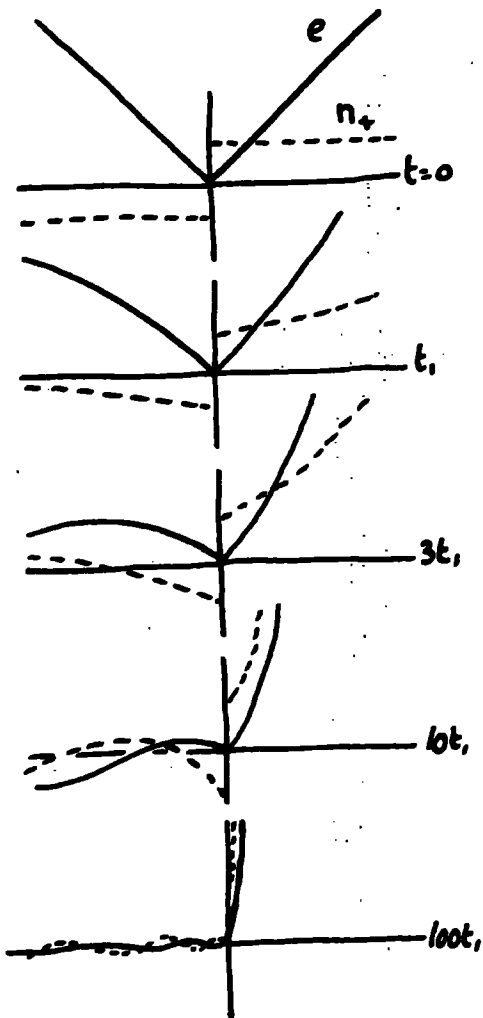
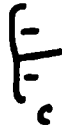

Reference: Pekarek and Krejci, 19...

Course of solutions for deflection from Equilibrium.

of the electrons and ions, (c) the creation of additional electric fields due to the creation of space charges. The chain of processes causing stratification of the positive column and the course of solutions for the deflection from the equilibrium state of concentration of positive ions (n_+) and additional electric field (e) for five different moments of time is shown in figure 48. The striations develop only on the side towards the anode from the place where the equilibrium state is disturbed. The discharge in the region between the disturbance and the cathode is unstable. In a real plasma, influences exist which have not been taken into consideration such as finite Debye length and the condition of equality of current through different cross-sections.

Kocian and Kracik (1961) carried out an experimental investigation in argon (plus heavy organic molecules). The direct and alternating currents at which the striations appeared and the voltages across the discharge tube were determined as a function ^{of} pressure.

Depending on the current and pressure, the positive column could be in the form of a helix or a number of separate striae. A rotating positive column could be observed at a certain critical current.

A STUDY OF METHODS OF MEASUREMENT OF THE ELECTRIC CHARGE ON A ROCKET
AND OF AMBIENT ELECTRIC FIELDS USING PROBE TECHNIQUES.

SECTION II. ACCOUNT OF EXPERIMENTS.

CHAPTER 9. THEORETICAL DISCUSSION.

	Page No.
Introduction.	107
Theoretical Discussion.	107
Appendix - Note on Sheath Collisions.	111
Appendix - Note on Probe Location.	112

INTRODUCTION.

The theoretical discussion presents the Engel and Steenbeck (1932) theory for the use of cylindrical probes, applies this to the experimental work in hand, and sets it by the side of modern theory. Sheath collision theory is presented in the light of the author's concept that the absence of collisions in the sheath depends ultimately, in a complex way, upon the percentage of the gas molecules which are ionised.

The theory of rocket motion is developed to find how the location of the probe is determined by the "free" motion of the rocket. This last has of course no bearing on the experimental work.

THEORETICAL DISCUSSION.

A plane probe disturbs the discharge as too much charge is removed from the plasma. Theories for cylinders collecting only ions of one sign (and under conditions such that the ion free path is much greater than the sheath radius) have been obtained. The theory was put in a convenient form by Engel and Steenbeck (1932). Accordingly we turn our attention to this work.

Figures 49 and 50. Cylindrical and Spherical Probes.

To face page 108.

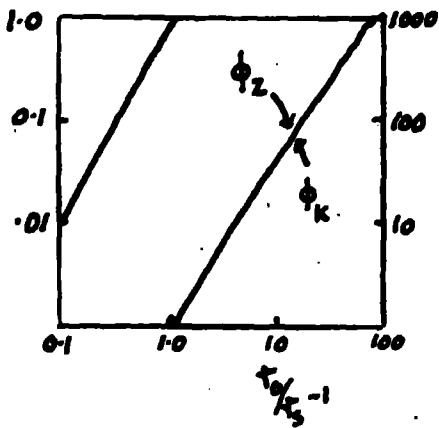

Figure 49.

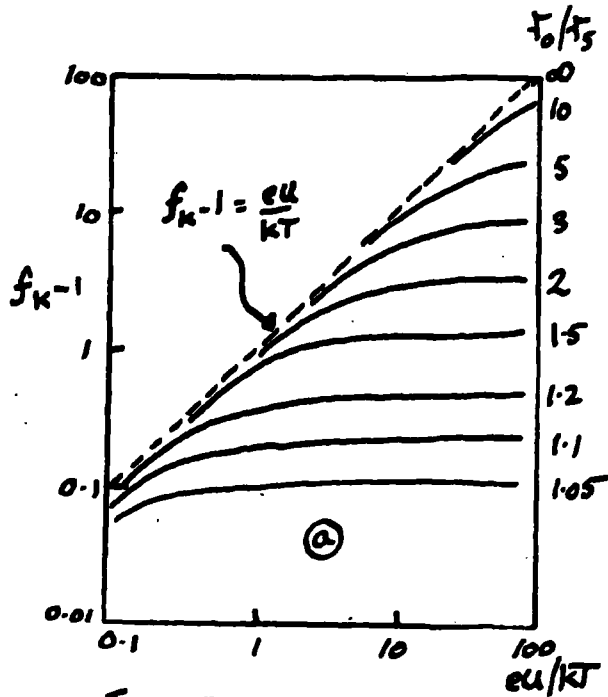
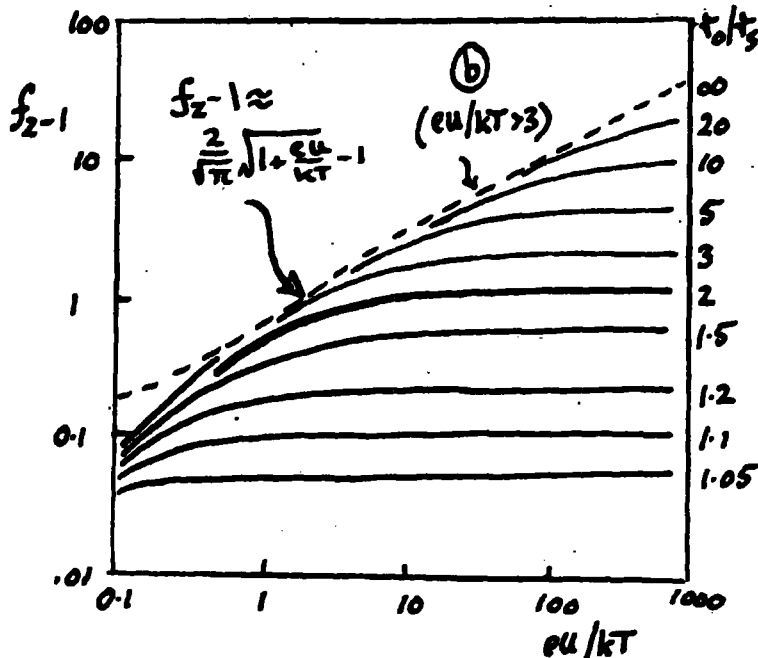

Figure 50.

Reference:-
Engel and Steenbeck;
1932.



In fig. 49 it has not been possible to resolve ϕ_2 from ϕ_k .

They considered first the case of a negative collector. If the current is limited by the size of the sheath, then eV/kT is very much greater than r_0/r_s , where r_0 is the sheath radius and r_s the probe radius. The ion saturation current is given by:-

$$I_p = 4\pi r_0^2 \frac{v_+ n_+ e}{4} = \frac{1}{9\xi_0 \pi} (2e/m_+)^{1/2} v^{3/2} / \phi_K \dots \text{Spheres} \dots \text{Equn. 49a.}$$

$$I_p = 2\pi r_0 \frac{v_+ n_+ e}{4} = \frac{1}{18} (2e/m_+)^{1/2} v^{3/2} / \phi_{1/2} r_s \dots \text{Cylinder of unit length.} \dots \text{Equn. 49b.}$$

The factors ϕ_K and $\phi_{1/2}$ are plotted in figure 49 for sheaths of various sizes relative to the probe size. These equations are subject to correction for the velocity of agitation of the ions when they enter the sheath. In principle the plasma potential can be found from the position of the inflexion point in the current-voltage characteristic.

Next they considered the case of a positive collector. If the current is limited by orbital motion, then eV/kT is very much less than r_0/r_s . We can replace I_p by I_e and m_+ by m_e . Because of the great difference in the masses, for equal currents ϕ and r_0 are much greater. The question arises: how many electrons shoot past the probe in comet-like paths?

With the notation of figure 50:-

$$I_e = I_p \times \frac{f_K}{2} \quad (\text{see figure 50}) \dots \text{Equn. 50.}$$

$(r_0=r_s)$

For small values of eV/kT_e and large values of r_0/r_s , we have

$$f_K = 1 + eV/kT_e \dots \text{Equn. 51a.}$$

Figure 51. Semilogarithmic Plot.

To face page 109.

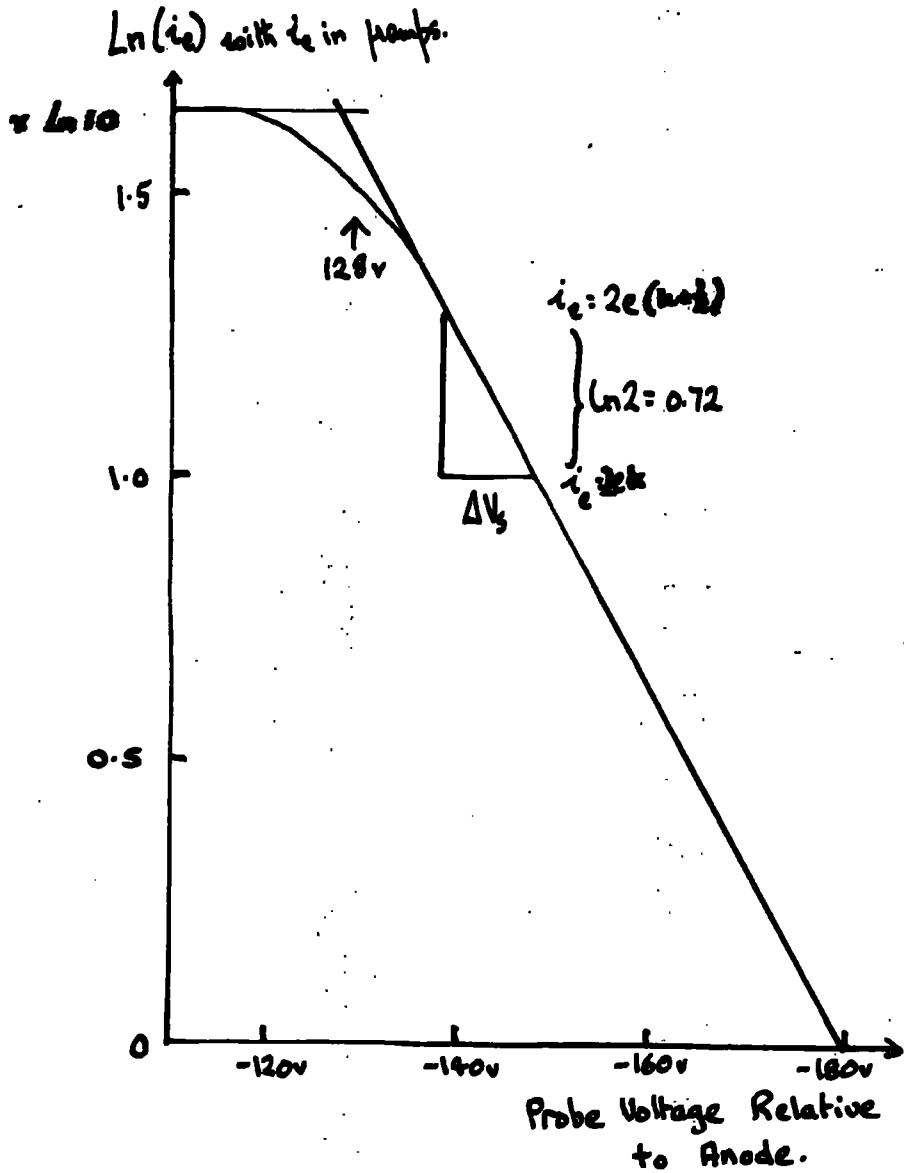
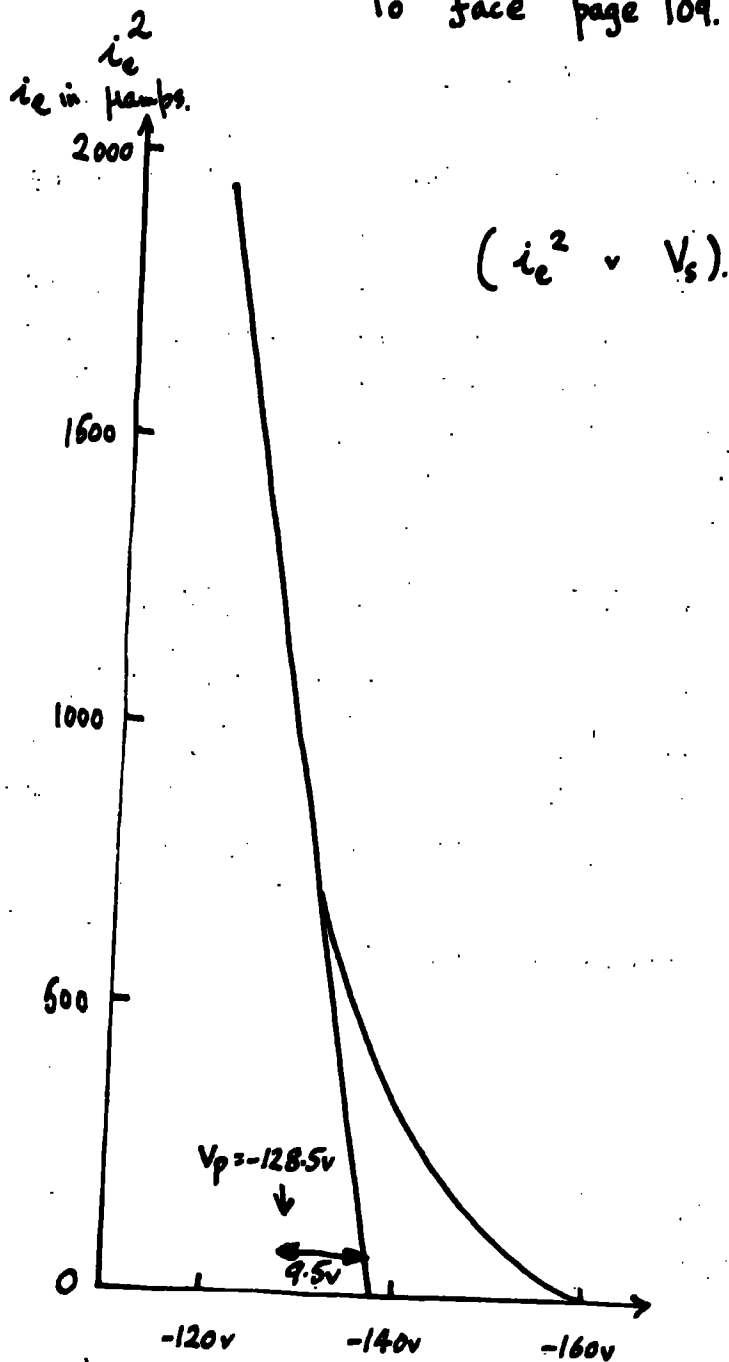

Figure 52. Space Potential Determination.

To face page 109.



Probe Voltage Relative to Anode.

Thus for a spherical collector, the space potential can be found from the graph of current against voltage. For not so small values of eV/kT_e and large values of r_0/r_s :-

$$f_z = 2(1 + eV/kT_e)^{1/2} / n^{1/2} \quad \dots \text{Equn. 51b.}$$

Thus for a cylindrical collector, the current squared is plotted against voltage. (See figure 52).

We will apply these theoretical arguments to our experimental results, and then examine the theory in the light of more recent work on probe theory. From the semilog plot (figure 51):- For a change in current equal to $e = 2.718$, the change in voltage V_s is 9.5 volts.

We can write:-

$$1/\partial V_s = e/kT_e = 1.17 \times 10^4 / T_e. \text{ Hence } T_e = 111,000^\circ \text{K.}$$

The tangents intersect for a space potential of 128 volts.

From the current squared plot (figure 52), deducting the 9.5 volts from the intersection voltage (tangent with voltage axis) gives a space potential of -128.5 volts (relative to the anode).

At 128.5 volts, $i = 30 \mu$ amps from figure 47 thus $j_e = 2 \times 10^{-4}$ amps/cm², the surface area of the probe being $\pi/20$ cm².

$$j_e = en_e (kT_e / 2\pi m_e)^{1/2} \quad \dots \text{Equn. 52.}$$

Hence:-

$$n_e = 2 \times 10^7 \text{ elec/cc.}$$

$$v_e = 0.5 \times 10^8 \text{ cm/sec.}$$

$$\lambda_D = 0.53 \text{ cm.}$$

The following values have been assumed for constants:-

$$m_e = 9.1 \times 10^{-28} \text{ gm}$$

$$e = 1.6 \times 10^{-19} \text{ coulombs}$$

$$k = 1.38 \times 10^{-16} \text{ erg/}^\circ\text{K.}$$

Modern theory attributes the ion velocities to the electric fields through which they pass. The presence of an electrode is responsible for the ion current flowing to it, by reason of its influence, as a boundary condition, on the potential distribution in the plasma. Unless a certain criterion is satisfied the probe field will penetrate into the plasma and modify the energy distribution so that it is satisfied. Thus orbital motions of the ions need not be considered since at the sheath edge their velocities are almost wholly normal to the edge. Also the flux of positive ions into the sheath is determined by the electron temperature. The collection of positive ions is discussed on page 73.

Figure 53. Critical Ionization.

To face page 111.

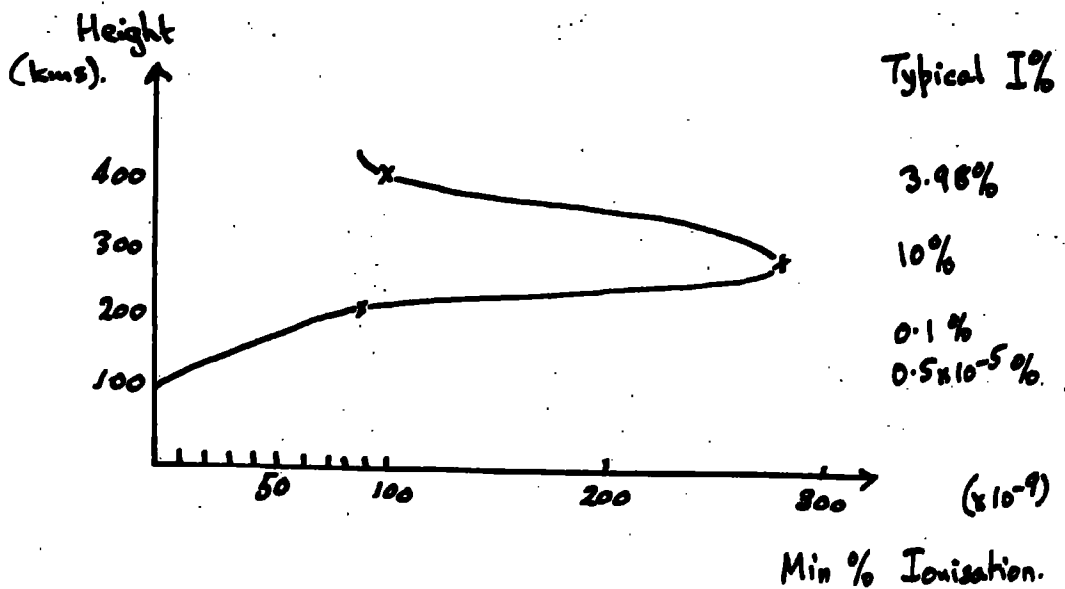

The typical values of I% are obtained using the data in chapter 3.

APPENDIX TO CHAPTER 9

NOTE ON SHEATH COLLISIONS.

The author has not seen a satisfactory theoretical treatment for the condition that no collisions occur within the sheath.

There will be collisions in the unipolar charge sheaths unless λ_e is greater than λ_D .

$\lambda_e = 4/nd^2$ where n is the number of molecules per unit volume
 d is the molecular diameter = 3.65×10^{-10} metres.

$$\lambda_D = 69.0(T_e/n_e)^{1/2}$$

Let $I\% = 100 \frac{n_e}{n_+ + n_0}$ where n_0 is the concentration of neutral particles.

By rearranging terms it can be shown that there will be collisions in the sheath unless $I\%$ is greater than:-

$$7.2 \times 10^{-16} (T_e n_e)^{1/2} \dots \text{Equn. 53.}$$

Figure 53 shows that between 100 and 400 kms the typical ionisation level far exceeds the limiting minimum level for collision free sheaths. If, at a less height, insufficient gas molecules are ionised, there will be collisions in the sheath.

For the experimental system considered, we have

$$I\% = 2 \times 10^{-4\%}$$

$$\text{Limiting ionisation} = 0.1 \times 10^{-4\%}$$

Thus we can assume that there are no collisions in the sheath.

Figure 54. Probe Location.

To face page 112.

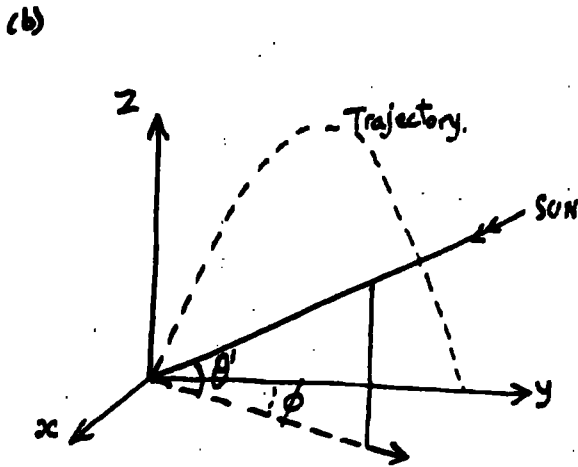
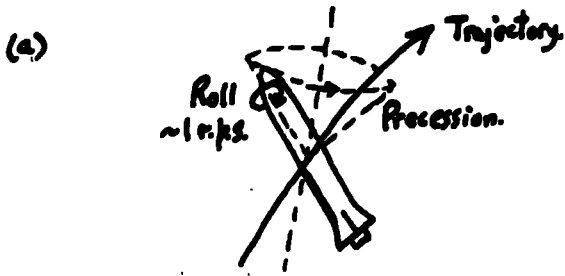

θ' and ϕ define the plane of the trajectory with respect to the sun.

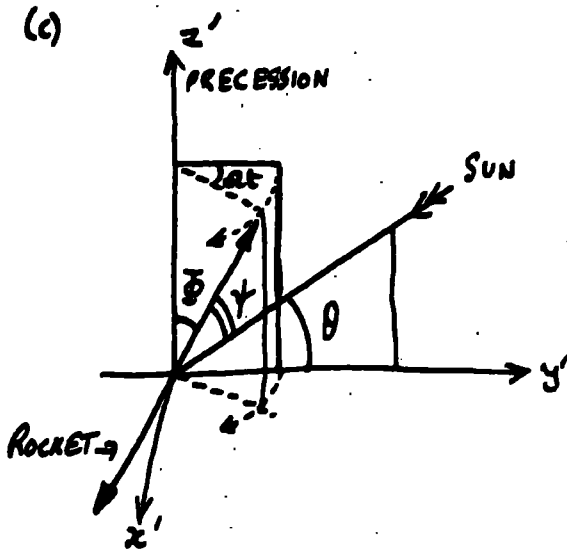

ψ = angle between sun and rocket.
 θ defines the axis of precession with respect to the sun.

$$\cos \psi = K \cos \theta t + C$$

$$\left. \begin{aligned} K &= \cos \theta \sin \phi \\ C &= \cos \phi \sin \theta \end{aligned} \right\} \text{constants.}$$

.... Equn 54.

Figure 54 continued.

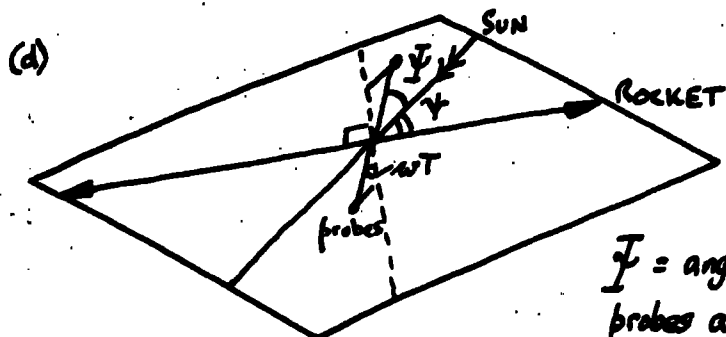

I = angle between
probe and sun.
 w represents the
roll of the rocket.

$$\cos I = \frac{\sin^2 w T \cos^2 \gamma - \sin^2 \gamma \cos^2 w T + \cos^2 \gamma + \cos^2 w T}{2 \cos \gamma \cos w T}$$

.... Eqn. 55.

It has been assumed that the axis of the rocket never crosses the line from the sun, and that the sun is at infinity. The equations can be used to bring in magnetic fields with the angle of dip as a parameter.

NOTE ON PROBE LOCATION.

This has no bearing on experimental work but is intended to develop the theory of rocket motion. It has been stated already that all the rockets of the U.S.A.F. space flight physics laboratory are free flight, aerodynamically stabilized vehicles, and that after burn-out of the fuel, and before the vehicles re-enter the dense atmosphere, they move freely in the gravitational field. There is no evidence of gravity, but there is a centrifugal acceleration field, provided by causing the vehicles to rotate. The motion of the rocket after burn-out is determined by the linear and angular momenta it had when the rocket motor, steering jets, or aerodynamic forces ceased. In considering the roll and precession of an unstabilized rocket, it should be borne in mind that the axes of rotation are fixed in space, and not relative to the flight path.

The location of a probe is illustrated through figures 54a to 54d. The point to be noted is that there is a predictable relation between time and orientation.

**A. STUDY OF METHODS OF MEASUREMENT OF THE ELECTRIC CHARGE ON A ROCKET
AND OF AMBIENT ELECTRIC FIELDS USING PROBE TECHNIQUES.**

SECTION III. METHODS OF MEASUREMENT.

CHAPTER 10. DESIGN CRITERIA.

1. Review of the Position of the Present Research.
2. The Electric Charge on a Rocket.
3. The Ambient Electric Field.
4. Laboratory Measurements of Space Potential.
5. Analysis of Experimental Work - Voltage Gradients - Possibilities of Simulation.
6. Measurements of Ambient Fields by Simultaneous Determinations of Potential.
7. The Physics of Re-entry.
8. Definite Experimental Proposals.

1. REVIEW OF THE POSITION OF THE PRESENT RESEARCH.

From an analysis of the available material it seems there is no lack of techniques available for the measurement of the charge on a rocket, and this problem was the most important part of the work.

The group at Bedford, Massachusetts, have apparently concentrated on the experimental side of probe studies. Again, although the Michigan group have published experimental and theoretical papers, their very extensive work unfortunately does not take into full consideration all the early studies made by Langmuir and the very useful reformulation of the theory by Engel and Steenbeck, nor the refinements due to Boyd working at University College, London.

Hence it is hoped that a report prepared from the present survey will fill a gap in the literature available for interpreting the results of the probe work carried out by the United States Air Force.

2. THE ELECTRIC CHARGE ON A ROCKET.

The potential assumed by a rocket (between 0 and 10 volts) has been determined by the following methods which have already been described:-

- i. From the signal from a D.C. amplifier between a probe and the tip of a rotating rocket. Page 82.
- ii. From the signal obtained with a sawtooth voltage variation between the vehicle surface and a grid surrounding the probe. (The theory given is for orbital speeds.) Page 84.
- iii. From the signal obtained at maximum measured electron concentration. This condition is obtained by a sawtooth voltage variation between the rocket and its insulated nose cone. Page 86.
- iv. From the signal obtained upon varying the voltage of the grid controlling a mass spectrometer. Page 87.

The choice of a method must depend on what other parameters it is required to determine. (In the present case the ambient electric field is also required.)

At a geophysical discussion held by the Royal Astronomical Society (24th November 1961) it was pointed out by Boyd (1961) that the potential of a space vehicle is not well determined, and that this had recently been overcome in the United States on Explorer 8 Satellites by making probe measurements in a very short time so that the potential cannot vary during the measurement. This needs extensive telemetry, and the British approach is to analyse the data in the rocket.

3. THE AMBIENT ELECTRIC FIELD.

The ambient electric fields experienced by a rocket have been measured in the following ways:-

- i. From the signal from an A.C. amplifier between a probe and the tip of a rotating rocket. Page 82. (60 μ V/km)
- ii. From field meter techniques. Page 83. (200 V/m.)

Calculations of the horizontal components of the electric field yield a value orders of magnitude too low. (0.02 V/km, but this must be multiplied by the tidal amplification factor). Page 55.

Farley (1959), for instance, has attempted to fit the electron densities as determined by the rocket exploration of the upper atmosphere into a theory of electric fields. This must ultimately be coupled with field determinations, and results will have to be determined and interpreted using techniques such as those described by Briggs and Rishbeth (1961) - page 47, rather than in terms of "slab models" (Ratcliffe, 1960).

4. LABORATORY MEASUREMENTS OF SPACE POTENTIAL.

The laboratory methods which have been described for determining the space potential in a discharge are, in order of increasing accuracy:-

- i. From the current-voltage-temperature characteristics of a tungsten filament. Page 61.
- ii. From the (ill-defined) turning point in the current-voltage characteristic of a plane cold probe. Page 62.
- iii. From the Semilogarithmic Plot (Boltzmann's relation breaks down). Page 65. The space potential may be taken as the point (A, figure 25, page 71) at which the tangents to the semilogarithmic plot intersect, or -
- iv. As the point on the semilogarithmic plot of its departure from linearity.
- v. From an analysis of the semilogarithmic plot and the current squared plot using a cylindrical probe. Page 109.
- vi. From the second derivative of the probe characteristic. Page 71.

5. ANALYSIS OF EXPERIMENTAL WORK - VOLTAGE GRADIENTS - POSSIBILITIES OF SIMULATION.

From the determination of the random current to the probe and the space potential (page 109) it would appear that the discharge current is not greater than about 10^{-4} amps and that the free column voltage gradient is

is greater than 10 V/cm. An extrapolation over a pressure range of 10^4 using proper variables (page 32) of the gradients (10^{+3} V/cm - page 33) for a discharge current of 10^{-4} amps at atmospheric pressure leads to a predicted gradient of the order of 10^{-1} V/cm. The very much higher gradients measured might be explained by the effects associated with the striations which can involve gradients in excess of 10 V/cm (page 32). The probe structure seems in any case to have been responsible for their presence - page 105).

This does not affect the utility of the probe characteristic as such although it may well represent some kind of average of the potential.

But the important point to note is that although field measurements using probes are possible in discharges, much higher gradients exist in these discharges than those which are found in the Upper Atmosphere.

Thus to simulate in the laboratory the measurement of electric fields by simultaneous determinations of potential at two places would require the probes to be placed very near each other, and this would disturb conditions too much. (This method is considered in the next section). However low voltage gradients exist under A.C. breakdown (page 34). Bazelyan, Brago, and Stekolnikov, in a paper (1960) which the author has not seen, found a significant reduction of the mean breakdown gradients in long discharge gaps with an oblique voltage wave. They explained this by the short time available for building up and propagating a space charge - under the effect of an oblique wave or in A.C. conditions, the zone of propagation of the unipolar space charge is much smaller and independent of electrode spacing. So there is some hope of simulation for testing this method of ambient field measurement.

6 MEASUREMENTS OF AMBIENT FIELDS BY SIMULTANEOUS DETERMINATIONS OF POTENTIAL.

The author had hoped that it would be possible to suggest a method for determining the ambient electric field by a simultaneous determination of the potential on either side of a rocket. But from theoretical studies the ambient field is predicted to be $\frac{1}{10}$ volts/km, and even when this is

multiplied by a tidal amplification factor of 50 the field is only 100 mV/m. This is consistent with the 60 mV/m obtained in probe experiments but orders of magnitude different from the result obtained with field meter techniques. As the probes cannot be more than 10 metres apart, it would be necessary to detect a potential difference of $\frac{1}{2}$ volt. This would require an accuracy of 0.05 volts in the determinations of space potential. Figure 47 shows that an error of 5 volts is possible in the determination of space potential from the characteristic itself, so this approach would make sense only in measuring fields like 200 V/m. Again, figure 47 indicates that an accurate determination of space potential is possible only from a full analysis of the characteristic. To do this would make heavy demands on circuitry. Figure 25 shows that an error of 0.1 volts may be obtained using the semilogarithmic plot to obtain the space potential. But the method using the derivative technique (figure 25) might work with a suitable development of a circuit of the type used by Sloane and McGregor (1934), as also might a complete analysis (by means of circuitry in the rocket itself) of a spherical probe characteristic using the ^{Von}Engel and Steenbeck (1932) method. Circuitry is outside the scope of the present research, so it is not possible to give a more definite answer.

7. THE PHYSICS OF RE-ENTRY. — WITHDRAWN

The probes flown on skylark were placed 4 feet in front of the rocket nose cone, and Boyd has pointed out (page 89) that in the D region the probe should be well ahead of the shock wave. Apparently Benson studied low pressure shock waves using active Nitrogen (otherwise they are not visible) directed in a stream onto a rocket profile. At the time of writing this the author is studying a paper on shock waves about rocket nose cones produced by A.V. Roe. From the letter by Smiddy (1960) it appears that fields of 5000 to 10,000 volts/metre are produced at reentry. The author hopes to have something on this ready to include in the report to the U.S.A.F. but the subject must be omitted from the present thesis.

8. DEFINITE EXPERIMENTAL PROPOSALS.

A Recent Development.

Druyvesteyn (1930, Z.f.Physik 64, p.790) employed two successive graphical differentiations. This process can, however, lead to quite large errors, and Sloane and MacGregor (1934) developed a method, suggested first by Emeleus, of superposing a small alternating e.m.f. on the steady probe potential. Emeleus reports difficulties with this method caused by interaction of the alternating e.m.f. with the plasma. Gas discharge plasmas are prolific sources of noise and oscillations, and differentiating circuits accentuate these, making double differentiation using two networks generally impossible. It is possible, however, with care, to obtain the first differential coefficient (of the probe current signal with respect to the probe potential applied in a time dependent manner) by this method and then to use graphical differentiation once only, which reduces labour and error considerably. Plasma oscillations may be so bad as to render the oscilloscope trace unintelligible, but at the same time any other method available will be no more meaningful. (Smithers, 1962, "Electron Energy Distributions in Gas Discharges", J.Sci.Instrum. p.21.)

Author's Recommendations.

At the present state of this work any proposals are essentially of a very tentative nature. The material quoted in the preceding paragraph only enhances the author's opinion that attempts at laboratory simulation should be discontinued in favour of building equipment which can be flown - a "suck it and see" approach. This seems the only basis for determining whether the proposed method for studying ambient fields - simultaneous determinations of space potential at two points - is or is not practical. It has the following merits.

- i. The technique proposed is a familiar one in space experimentation, so there is no need to make a design study apart from the development of new circuitry.
- ii. Even if no information is obtained about ambient fields, the trial would not be a waste of money, as it should be quite easy to arrange matters so as to obtain the information normally available from rocket-borne probes.

It is not necessary to discuss the relative merits of the proposed device and existing methods for field study because of the general agreement in space research that it is extremely desirable to measure given space parameters by more than one technique.

(It must be borne in mind that the results of a parallel study at the U.S.A.F. laboratories are not available at the time of writing, which circumstance makes the above remarks even more tentative.)

An Additional Acknowledgment.

The final chapter has been written only after the completion of the typing of the rest of this work. The author is now working at the Electrical Research Association, Leatherhead, Surrey and has profited from the Information Service here during the final revision of this work. Mr. L.A. King provided information on arc physics which involved re-writing chapter 2, and also he very kindly read through the draft of chapter 2 when it was completed.

CONCLUDING REMARKS.

The author has been pleased to attempt the task of introducing a new branch of atmospheric electricity research in the department where this work has been undertaken. To show that it is not outside the proper scope of atmospheric electricity, the following quotation is given from the introductory remarks to the proceedings of the second conference on atmospheric electricity (New Hampshire, 1958):- Technology is now pressing so rapidly after fundamental knowledge that we are being urged to answer practical questions which are at the same time fundamental. The problems of ionic drag on satellite vehicles; ionic propulsion of space vehicles, space-charging of space vehicles as a result of solar radiation; these and many other similar problems are of immediate and practical interest, and our science is being taxed for answers. In the very near future we will have to answer a multitude of questions about electrical fields in space and in the atmosphere of the other planets. The classical fields of inquiry in the electricity of the terrestrial atmosphere, in cloud physics and weather modification remain an essential part of geophysics.

**A STUDY OF METHODS OF MEASUREMENT OF THE ELECTRIC CHARGE ON A ROCKET
AND OF AMBIENT ELECTRIC FIELDS USING PROBE TECHNIQUES.**

REFERENCES

1. ALLEN, BOYD, REYNOLDS. 1957. "The Collection of Positive Ions by a Probe immersed in a Plasma". Proc. Phys. Soc. B.70. p.297.
2. VAN ALLEN. 1959. "The Geomagnetically Trapped Corpuscular Radiation". Jour. Geophys. Res. 64. p.1683.
3. ALLIS. 1956. "Motions of Ions and Electrons". Handbuch der Physik. 21. p.383.
4. VAN BERKEL. 1938. "Einfluss von Änderungen des Sondenzustandes auf Sondencharakteristiken nach Langmuir". Physica 5. The Hague. p.230.
5. BERKNER. 1958a. "Manual on Rockets and Satellites". Annals of the I.G.Y. Volume 6. p.58.
6. BERKNER. 1958b. "Manual on Rockets and Satellites". Annals of the I.G.Y. Volume 6. p.76.
7. BERKNER. 1958c. "Manual on Rockets and Satellites - Charge Drag". Annals of the I.G.Y. Volume 6. p.165.
8. BLEANEY AND BLEANEY. 1957. "Electricity and Magnetism". p.332.
9. BOGGESS. 1959. "Electrostatic Probe Measurements of the Ionosphere". University of Michigan.
10. BOYD. 1954. "Rocket Exploration". p.336.
11. BOYD. 1958. "Instruments in Sputnik III". New Scientist. May 22.
12. BOYD. 1959a. "A Discussion on Space Research - Some Techniques of Physical Measurement". Proc. Roy. Soc. A. 253. p.516.
13. BOYD. 1959b. Meeting at Durham. October 26.
14. BOYD. 1960a. "Electron Temperature". Discussion on the British Rocket Programme at the Royal Society of Arts. March 4.

15. BOYD. 1960b. Discussion at University College, London. April.
16. BOYD. 1961. Geophysical Discussion, Royal Astronomical Society. November 24.
17. BOYD AND THOMPSON. 1959. "The Operation of Langmuir Probes in Electronegative Plasmas". Proc. Roy. Soc. A. 252. p.102.
18. BOYD AND TWIDDY. 1954. "Electron Energy Distribution in the Striated Hydrogen Discharge". Nature. April 3.
19. BOYD AND TWIDDY. 1959. "Electron Energy Distribution in Plasmas". Proc. Roy. Soc. A. 250. p.53.
20. BRADDICK. 1956. "Physics of Experimental Method".
21. BRIGGS AND RISHBETH. 1961. "An Analogue Solution of the Continuity Equation of the Ionospheric F Region". Proc. Phys. Soc. 78. p.409.
22. CHAPMAN. 1951. "The Earth's Magnetism". Second Edition.
23. CHAPMAN. 1956. "The Electrical Conductivity of the Ionosphere: a Review". Nuovo Cim. Suppl. 4. p.1385.
24. COBINE. 1941. "Gaseous Conductors".
25. DICKINSON AND SAYERS. 1960. "Ion Charge Exchange Reactions in Oxygen Afterglows". Proc. Phys. Soc. 76. p.137.
26. ECCLES. 1912. "On the diurnal variation of the electric waves occurring in nature and on the propagation of electric waves round the bend of the earth". Proc. Roy. Soc. 87. p.79.
27. EDWARDS' 1961 Speedivac Catalogues.
28. EMELEUS. 1951. "Conduction of Electricity through Gases". Third Edition.
29. VON ENGEL. 1955. "Ionized Gases".
30. ENGEL AND STEENBECK. 1932. "Elektrische Gasentladungen". Band 2.
31. FARLEY. 1959. "A Theory of Electrostatic Fields in a horizontally stratified Ionosphere subject to a vertical magnetic field". Jour. Geophys. Res. 64. p.1225.

32. FEJER. 1953. "Semidiurnal Currents and Electron Drifts in the Ionosphere". Jour. Atmos. Terr. Phys. 4. p.184.
33. HANDBOOK OF GEOPHYSICS for Air Force Designers. 1957. (U.S.A.F.)
34. HANDBUCH DER PHYSIK. 1956. Volumes 21 and 22. (Including "The Glow Discharge at Low Pressure". Gordon Francis).
35. HAYWARD. 1960. "Choice of Flexible Tubing". Lab. Practice. February.
36. "HIGH ALTITUDE SOUNDING ROCKETS of the Space Flight Physics Laboratory". 1961. U.S.A.F. circular.
37. HINES. 1959. "Motions in the Ionosphere". Proc. Inst. Radio Engrs. 47. p.176.
38. HOEGY AND BRACE. 1961. "The Dumbbell Electrostatic Ionosphere Probe: Theoretical Aspects". University of Michigan.
39. HOK AND DOW. 1954. "Rocket Exploration". Edited by R.L.F.Boyd. p.240 .
40. HOK, SPENCER, DOW. 1953. "Dynamic Probe Measurements in the Ionosphere". Jour. Geophys. Res. 58. p.235.
41. HOK, SPENCER, REIFMAN AND DOW. 1958. "Dynamic Probe Measurements in the Ionosphere". University of Michigan.
42. HOLMBERG. 1952. "A Suggested Explanation of the Present Value of the Velocity of Rotation of the Earth". Monthly Notices Roy. Astron. Soc. Geophys. Suppl. 6. p.325.
43. IMYANITOV. 1957. "Measurement of Electrostatic Fields". Uspekhi Fizicheskikh Nauk. 63. p.267.
44. KELVIN. (W.THOMSON). 1882. "On the thermodynamic acceleration of the earth's rotation". Proc. Roy. Soc. Edinburgh. 11. p.396.
45. KING. 1961. "The Voltage Gradient of the Free-burning Arc in Air or Nitrogen." E.R.A. Report G/XT172.
46. KOCIAN AND KRACIK. 1961. "Conditions of Appearance of a low-pressure Striated Discharge". Slaboproudny Obzor (Czechoslovakia). 22. p.16.

47. KRASSOVSKY. 1959. "Exploration of the Upper Atmosphere with the Help of the Third Soviet Sputnik". Proc. Inst. Radio Engrs. 47. p.289.
48. LANGMUIR. 1923a. "Positive Ion Currents in the Positive Column of the Mercury Arc". Gen. Elec. Rev. 26. p.731.
49. LANGMUIR. 1923b. "The Pressure Effect and Other Phenomena in Gaseous Discharges". Jour. Franklin Inst. 196. p.751.
50. LANGMUIR. 1929. "The Interaction of Electron and Positive Ion Space Charges in Cathode Sheaths". Phys. Rev. 33. p.954.
51. LANGMUIR AND MOTT SMITH. 1924. "Studies of Electric Discharges in Gases at Low Pressures". Gen. Elec. Rev. 27. pp.449, 538, 616, 726, 810.
52. MARTIN AND HILL. 1947. "A Manual of Vacuum Practice".
53. MINZNER, CHAMPION, POND. 1959. "A.R.D.C. Model Atmosphere". (U.S.) Air Force Surveys in Geophysics No. 115.
54. MORGAN. 1959. "The Nature of the Ionosphere - An I.G.Y. Objective". Proc. Inst. Radio. Engrs. 47. p.132.
55. MORSE, ALLIS, LAMAR. 1935. "Velocity Distributions for Elastically Colliding Electrons". Phys. Rev. 48. p.412.
56. MOTT SMITH AND LANGMUIR. 1926. "The Theory of Collectors in Gaseous Discharges". Phys. Rev. 28. p.727.
57. NEAT. 1960. (Chief Engineer de Havilland's Rocket Engine Division). Letter.
58. OSKAM. 1957. "Microwave Investigation of Disintegrating Gaseous Discharge Plasmas".
59. PEKAREK AND KREJCI. 1961. "The Physical Nature of the Production of Moving Striations in a D.C. Discharge Plasma". Czech. Jour. Phys. B. 11. p.729.
60. POST. 1959. "Plasma Research". Ann. Rev. of Nuclear Science. No. 9.

61. RATCLIFFE. 1959. "The Highest Parts of the Ionosphere". Quart. Jour. Roy. Met. Soc. 85. p.321.
62. RATCLIFFE. 1960a. "Physics of the Upper Atmosphere". p.380.
63. RATCLIFFE. 1960b. "Physics of the Upper Atmosphere". p.392.
64. RATCLIFFE. 1960c. "Physics of the Upper Atmosphere". p.397.
65. SAYERS. 1959. "Self Contained Measuring Equipment for Electron Density and Ionic Mass Spectrum". Proc. Roy. Soc. A. 253. p.522.
66. SAYERS. 1960. "Electron and Ion Distribution in the Ionosphere". Discussion on the British Rocket Programme at the Royal Society of Arts. March 4.
67. SAYERS AND COURT. 1961. Discussion at Electron Physics Department, Birmingham. May.
68. SCIENCE NEWS 48. 1958. "Rocket and Satellite Research Number". (Including "Rocket Motors and Propulsion" by HEAT and "The Rocket-borne Laboratory" by BOYD).
69. SLOANE AND MCGREGOR. 1934. "An A.C. Method for Collector Analysis of Discharge Tubes". Phil. Mag. 18. p.193.
70. SMIDDY. (U.S.A.F.) 1959. Discussion at Durham. September 16.
71. SMIDDY. 1960. Letter. January 18.
72. SPENCER-SMITH. 1935. "Negative Ions of Iodine. Part I. Probe Measurements". Phil. Mag. 19. p.806.
73. SPENCER-SMITH. 1935. "Negative Ions of Iodine. Part II. Ion Beams". Phil. Mag. 19. p.1016.
74. SPITZER. 1956. "Physics of Fully Ionized Gases".
75. SUMMERFIELD. 1961. "Progress in Astronautics and Rocketry". Volume 5.
76. SUTTON. 1956. "Rocket Propulsion Elements". (New York).
77. TONKS AND LANGMUIR. 1929. "A General Theory of the Plasma of an Arc". Phys. Rev. 34. p.876.

78. TOWNSEND, 1947. "Electrons in Gases".
79. WEEKES AND WILKES. 1947. "Atmospheric Oscillations and the Resonance Theory". Proc. Roy. Soc. A. 192. p.80.
80. WHITLOCK. 1960. Discussion at S.E.R.L. October.

NOTE:-

The author has been unable to include reference to any work which had not come to his notice by the end of 1961.

NOTE:-

Reference 44 has been placed under K rather than T; The author of the paper concerned is correctly styled "Kelvin of Largs, William Thomson, 1st Baron". The procedure adopted is admittedly questionable since the peerage came ten years later than the paper referred to, in reference 44. William Thomson lived from 1824 to 1907.

NOTE:-

p. 118. "suck it and see". The author admits his diffidence to this principle to colloquial forms in a thesis.

