



# Durham E-Theses

---

## *Impact parameter treatments of excitation*

Kryisia M. Pluta,

### How to cite:

---

Kryisia M. Pluta, (1967) *Impact parameter treatments of excitation*, Durham theses, Durham University.  
Available at Durham E-Theses Online: <http://etheses.dur.ac.uk/10001/>

### Use policy

---

The full-text may be used and/or reproduced, and given to third parties in any format or medium, without prior permission or charge, for personal research or study, educational, or not-for-profit purposes provided that:

- a full bibliographic reference is made to the original source
- a [link](#) is made to the metadata record in Durham E-Theses
- the full-text is not changed in any way

The full-text must not be sold in any format or medium without the formal permission of the copyright holders.

Please consult the [full Durham E-Theses policy](#) for further details.

**Impact Parameter Treatments of Excitation**

by

**Krycia M. Pluta B.Sc. (London)**

**St. Aidan's College.**

**Thesis submitted to the University of Durham in  
application for the degree of Master of Science. 1967.**



## Introduction

This thesis is concerned with the first - order impact parameter method, with and without a cut - off at low impact parameters, as applied to collisional excitation of atoms.

In the first chapter we describe the method without a cut - off, giving a proof of its equivalence to the first Born approximation, and also give a review of previous calculations employing this method. The method is applied in Chapter II to the excitation of helium by electron and proton impact. The results are compared with the available Born approximation and experimental results.

Chapter III is a review of work on the first order impact parameter method with cut - off, applied to atomic excitation by electron impact. The theory developed by Stauffer and McDowell (1966), described in Chapter III, is applied in Chapter IV to the calculation of cross - sections for transitions in hydrogen between states of initial and final quantum numbers  $n$  and  $n'$  respectively. The results are compared with those obtained using versions of the classical impulse approximation.

## ACKNOWLEDGMENTS

I wish to express my gratitude to Dr. M.R.C. McDowell, my Supervisor, for all the help he has given me throughout my course. I would also like to thank Miss L.M. Hall on behalf of Southern Drawing Services Ltd., for her very skilful and accurate typing, and the Science Research Council for a research studentship.

## Table of Contents

	<u>Page</u>
Introduction ... ..	(i)
Acknowledgments ... ..	(ii)
 <u>Chapter I</u> The Semi-Classical Impact Parameter Method	
1.1 Introduction ... ..	1
1.2 The first - order impact parameter method for excitation ... ..	1
1.3 Equivalence of the Born approximation and the impact parameter method ... ..	5
1.4 Previous calculations employing the first - order impact parameter method ... ..	11
 <u>Chapter II</u> Collisional Excitation of Helium in the Impact Parameter Method	
2.1 Introduction ... ..	1
2.2 Theory ... ..	2
2.3 Results and discussion ... ..	15
 <u>Chapter III</u> The First - order Impact Parameter Method with cut - off	
3.1 Introduction ... ..	1
3.2 General theory ... ..	2
3.3 Justification of the method ... ..	8
3.4 Results and discussion ... ..	10

Chapter IV Electron excitation of  $n-n'$  transitions in hydrogen.

4.1	Introduction	...	1
4.2	The Classical Impulse approximation	...	3
4.3	Application of the Impact Parameter Method with cut - off	...	13
4.4	Results and discussion	...	17
	Figure captions for Chapter IV	...	19
	Graphs for Chapter IV	...	21
	Bibliography		

## CHAPTER I

The semi-classical impact parameter method.

§ 1.1

### Introduction.

Consider an inelastic collision between a charged particle and an atomic system.

In the impact parameter formulation the projectile and the nucleus of the target atom are regarded as classical particles. For sufficiently high velocities of relative motion.

transfer of energy and momentum may be neglected, and the classical trajectories taken to be rectilinear. The impact parameter  $\rho$ , defined as the distance of closest approach of projectile and target, plays the part of angular momentum through the

relationship

$$M_p v \rho = l \hbar$$

The method is semi-classical, since the motions of the atomic electrons must be treated quantum - mechanically. The projectile perturbs the atom, and the transition probabilities between various states of the atom are calculated by the method of variation of constants. Summing the contribution from all impact parameters gives the cross-section for a particular transition. In an exact calculation of the probabilities,

Bates (1961) shows that the principle of detailed balancing holds : that is, if  $P_{i \rightarrow f}$  denotes the probability of the transition from a state  $i$  to a state  $f$  of the atom then

$$P_{i \rightarrow f} = P_{f \rightarrow i}$$

### 1.2 The first-order impact parameter method for excitation

For simplicity, let the target system consist of a single electron moving in the field of an infinitely heavy nucleus of charge  $Z_1$ , which is located at the fixed origin of a coordinate system  $Oxyz$ . Let  $\underline{r}$  denote the co-ordinates of the atomic electron,  $H$  the hamiltonian of the unperturbed atom, and  $\phi_s(\underline{r}), E_s$  the wave

functions and energy values of the stationary states. Then

$$(H - E_s) \phi_s = 0 \quad (1.1)$$

We suppose that the system is perturbed by a potential  $V(\underline{r}, t)$ , and that

initially (at  $t = -\infty$ ) the atom is in the state  $s = i$ , so that the initial wave function of the system is

$$\Phi_i(\underline{r}, t) = \phi_i(\underline{r}) \exp(-iE_i t) \quad (1.2)$$

If  $\Psi(\underline{r}, t)$  is the wave function of the perturbed system at any subsequent time

then the Schrödinger equation for  $\Psi$  is

$$V\Psi = i \frac{\partial \Psi}{\partial t} - H\Psi \quad (1.3)$$

subject to the initial conditions (1.2).

$\Psi$  may be expanded formally in terms of either of the complete sets  $\phi_s$  and  $\Phi_s$

giving

$$\Psi_i(\underline{r}, t) = \sum_s a_{is}(t) \phi_s(\underline{r}) \exp(-iE_s t) \quad (1.4)$$

or, equivalently,

$$\Psi_i(\underline{r}, t) = \sum_s a_{is}(t) \Phi_s(\underline{r}, t) \quad (1.5)$$

We now make the assumption that  $|a_{is}|^2$  is equal to the probability that the

atom is in the state  $s$  at time  $t$ . To calculate the co-efficients  $a_{is}(t)$ , we

substitute (1.4) in the right-hand side of (1.3), obtaining

$$V\Psi_i = i \sum_s \frac{da_{is}(t)}{dt} \phi_s(\underline{r}) \exp(-iE_s t) \quad (1.6)$$

Multiplying both sides of (1.6) by any of the functions

$$\phi_s^*(\underline{r}) \exp[iE_s t] \quad (1.7)$$

and integrating over all  $\underline{r}$  gives

$$i \frac{d}{dt} a_{is} = \exp(iE_s t) \int \phi_s^*(\underline{r}) V(\underline{r}, t) \Psi_i(\underline{r}, t) d\underline{r} \quad (1.8)$$



The initial conditions give

$$a_{is}(-\infty) = \delta_{is} \quad (1.9)$$

so, integrating (1.8), we obtain ( $s \neq i$ )

$$a_{is}(t) = -i \int_{-\infty}^t dt \exp(i E_s t) \int \phi_s^*(\underline{r}) V(\underline{r}, t) \Psi_i(\underline{r}, t) d\underline{r} \quad (1.10)$$

This equation is exact but cannot be used to evaluate  $a_{is}$ , since the right-hand side contains the unknown function  $\Psi_i$ . If, however, we may assume that  $\Psi_i$  is changed only slightly during the perturbation, we may replace it by its initial form, and write

$$a_{is}(t) = -i \int_{-\infty}^t V_{si}(t) \exp(i E_{si} t) dt \quad (1.11)$$

$$\text{where } V_{si}(t) = \int \phi_s^*(\underline{r}) V(\underline{r}, t) \psi_i(\underline{r}) d\underline{r} \quad (1.12)$$

$$\text{and } E_{si} = E_s - E_i, \quad (1.13)$$

which is the first-order approximation.

Let the position of the perturbing particle at time  $t$  be  $R(t) = (X, Y, vt)$ ,  $v$  being the (constant) velocity of relative motion, and let  $\rho$  be the impact parameter. Changing the variable to  $Z = vt$ , the probability that the atom will be left in the state  $s$  after the collision is  $|a_{is}(\infty)|^2$

$$\text{where } a_{is}(\infty) = \frac{-i}{v} \int_{-\infty}^{\infty} V_{si}(X, Y, Z) \exp\left(\frac{i E_{si} Z}{v}\right) dZ \quad (1.14)$$

If  $\phi$  is the azimuthal angle (defined so that  $X = \rho \cos \phi, Y = \rho \sin \phi$ ), the cross-section for excitation from state  $i$  to state  $s$  is then given by

$$Q_{is} = \int_0^\infty \int_0^{2\pi} |a_{is}(\infty)|^2 \rho d\rho d\phi \quad (1.15)$$

If  $V_{sc}$  is spherically symmetric, this reduces to;

$$Q_{is} = 2\pi \int_0^\infty |a_{is}(\infty)|^2 \rho d\rho \quad (\text{in units of } a_0^2) \quad (1.16)$$

(Gaut, 1927).

The approximation made in obtaining (1.11) will be valid if the perturbation is "small". The significance of this will depend on the particular perturbation. For instance, if the perturbation is due to a positive ion of charge  $Z_2$  then

$$V(r, t) = \frac{-Z_1 Z_2}{|R - r|} \quad (1.17)$$

and the wave functions will certainly only be slightly perturbed during the collision if  $\rho$  is large. For large enough  $v$ , the condition will be satisfied even if the projectile passes through the atom. The method will also be valid if  $Z_2$  is small compared with  $Z$ .

The general conditions that must be satisfied for the first order impact parameter method to be valid are (a) that the incident particle moves in a straight line, with constant velocity relative to the target, (b) that the  $a_{is}(z)$  are all small, and (c) that electron exchange is unimportant

$i \neq s$  Condition (a) implies that we neglect the Coulomb repulsion between the incident particle and the atomic nucleus. Bates and Boyd (1962) show that, unless very strong Coulomb forces are involved, this introduces negligible

errors in calculations of excitation and ionization cross-sections, except at low impact velocities.

Condition (b), which ensures that the  $a_{is}$  do not vary much from their original values, is more restricting. Let  $P(Z) = \sum_{s \neq i} |a_{is}(Z)|^2$

Then if  $Z_M$  is the value of  $Z$  corresponding to the maximum value of  $P(Z)$  for any given  $\varrho$ , condition (b) holds providing

$$P(Z_M) \ll 1$$

When  $v$  is sufficiently high, the exponential in (1.14) may be replaced by unity. Hence, for simple excitation or ionization (when  $V(\underline{r}, t)$  is independent of  $v$ ),  $P(Z_M)$  falls off as  $v^{-2}$ , so the condition is satisfied at high velocities of relative motion. At lower velocities, however, it may be violated, and  $P(Z_M)$  may even exceed unity. For any given process it is impossible to calculate the  $a_{is}(Z)$  for all  $i, s$  and  $Z$ , but taking  $Z_M = \infty$  should give a reasonable approximation. Since optical transitions dominate, the condition (b) is likely to be satisfied if the probabilities for these transitions are all small.

Unless the projectile is a bare nucleus, there is a possibility that exchange with the atomic electron will take place. In general, however, this is unimportant at electron energies for which (a) and (b) are valid.

### § 1.3 Equivalence of the Born approximation and the impact parameter method

Since the physical assumptions are the same, we would expect Born's approximation in the wave treatment and the first-order impact parameter

method to be equivalent, provided the incoming particle may be treated classically. The mathematical equivalence of the two methods was examined by Frame (1931) who calculated cross-sections for the excitation of hydrogen-like atoms by bare nuclei. He considered  $S \rightarrow S$  transitions only, and found that both methods gave the same results in the limit of high incident energies and weak interactions. An error in his analysis was corrected by Arthurs (1961). Moiseiwitsch (1966) generalized the result to apply to any transition in the  $n^{\text{th}}$  order approximation, and Crothers and Holt (1966) extended it to the low and medium-energy range.

We give below the proof for excitation due to Mc. Carroll and Salin (1966), who consider for simplicity proton-hydrogen atom collisions.

Suppose a proton B is incident on a hydrogen atom nucleus A, electron E, and excites it from initial state  $i$  to final state  $f$ . Let

$\underline{s} = \underline{BE}$ ,  $\underline{r} = \underline{AE}$ ,  $\underline{R} = \underline{AB}$ ,  $\underline{r}' = \frac{1}{2} (\underline{r} + \underline{s})$ . Then  $\underline{r}'$  is the position vector of E relative to the centre of mass of the two protons.

Consider first the impact parameter method, in which the hydrogen atom is taken as stationary and  $\underline{R} = \underline{\rho} + \underline{v}t$ , where  $\underline{\rho}$  is the impact parameter and  $\underline{v}$  the (constant) velocity of B. In the centre of mass system, which has velocity  $\underline{v}/2$  relative to the original frame of reference, the time-dependent Schrödinger equation for the wave function of the perturbed system

is

$$\left[ -\frac{1}{2} \nabla_{\underline{r}'}^2 + \frac{1}{R} - \frac{1}{r} - \frac{1}{s} \right] \Psi_i(\underline{r}', t) = i \frac{\partial}{\partial t} \Psi_i(\underline{r}', t) \quad (1.18)$$

where, in the notation of § 1.2,

$$\Psi_i(\underline{r}', t) \xrightarrow{t \rightarrow -\infty} \Phi_i(\underline{r}', t) = \phi_i(\underline{r}) \times \exp(-iE_i t - \frac{i}{8} v^2 t - \frac{1}{2} i \underline{v} \cdot \underline{r}') \quad (1.19)$$

and the  $\frac{1}{R}$  term is retained for convenience.

Also, the final state wave function  $\Phi_f$  is given by

$$\Phi_f = \phi_f(\underline{r}) \exp(-\frac{1}{2} i \underline{v} \cdot \underline{r}' - \frac{1}{8} i v^2 t - iE_f t) \quad (1.20)$$

and  $\Phi_i$ ,  $\Phi_f$  satisfy

$$\left( \frac{1}{2} \nabla_{\underline{r}'}^2 + \frac{1}{r} + i \frac{\partial}{\partial t} \right) \Phi = 0 \quad (1.21)$$

By (1.5), the transition amplitude may be written

$$a_{if}(\infty) = a_{if}(\rho) = \lim_{t \rightarrow \infty} \int \Phi_f^* \Psi_i d\underline{r}' \quad (1.22)$$

Now consider the expression

$$\int d\underline{r}' \int_{-\infty}^{\infty} dt \left( \frac{\partial \Phi_f^*}{\partial t} \Psi_i + \Phi_f^* \frac{\partial \Psi_i}{\partial t} \right) \quad (1.23)$$

Integrating by parts gives

$$\left[ \int \Phi_f^* \Psi_i d\underline{r}' \right]_{-\infty}^{\infty} = a_{if}(\infty) - \lim_{t \rightarrow -\infty} \int \Phi_f^* \Psi_i d\underline{r}'$$

by (1.22). Thus, since  $\Psi_i \xrightarrow{t \rightarrow -\infty} \Phi_i$  and  $\Phi_i$

and  $\Phi_f$  are orthogonal,  $a_{if}(\infty)$  is equal to (1.23).

Using (1.18) and (1.21) in (1.23) gives

$$a_{if}(\underline{p}) = i \int d\underline{r}' \int_{-\infty}^{\infty} dt \Phi_f^* V \Psi_i \quad (1.24)$$

where  $V = \frac{1}{S} - \frac{1}{R}$  is the final perturbation.

We now write  $\Psi_i$  in the form

$$\Psi_i(\underline{r}', t) = \sum_j \Phi_j(\underline{r}', t) F(\underline{r}', t) \quad (1.25)$$

and let  $R(\underline{\eta}) = \int a_{if}(\underline{p}) e^{-i\underline{\eta} \cdot \underline{p}} d\underline{p}$  (1.26)

where  $\underline{\eta} \cdot \underline{v} = 0$ . Since

$$\begin{aligned} & \int |R(\underline{\eta})|^2 d\underline{\eta} \\ &= \int d\underline{p} \int d\underline{p}' a_{if}(\underline{p}) a_{if}^*(\underline{p}') \int e^{i\underline{\eta} \cdot (\underline{p}' - \underline{p})} d\underline{\eta} \end{aligned} \quad (1.27)$$

and  $\int e^{i\underline{\eta} \cdot (\underline{p}' - \underline{p})} d\underline{\eta} = 4\pi^2 \delta(\underline{p}' - \underline{p})$ , (1.28)

the cross-section is given by

$$\sigma = \int |a_{if}(\underline{p})|^2 d\underline{p} = \frac{1}{4\pi^2} \int |R(\underline{\eta})|^2 d\underline{\eta} \quad (1.29)$$

If we substitute (1.24) in (1.26) and use (1.25), (1.19) and 1.20), we may

write  $R(\underline{\eta})$  in terms of the unperturbed wave functions :

$$\begin{aligned} R(\underline{\eta}) = \sum_j \frac{1}{v} \iint d\underline{r}' d\underline{r} \Phi_f^* V \Phi_j \exp(iE_{f_j} t - i\underline{\eta} \cdot \underline{p}) \\ \times F_j(\underline{r}', t) \end{aligned} \quad (1.30)$$

We now consider the wave treatment of the problem. In the Born approximation, the cross - section is given by

$$\sigma = \frac{\mu^2}{4\pi^2} \frac{k_i}{k_f} \int |\tau_{if}|^2 d\Omega \quad (1.31)$$

where  $\underline{k}_i$  and  $\underline{k}_f$  are respectively the initial and final wave vectors of the incident particle,  $\mu$  is the reduced mass, and  $\tau_{if}$  is the transition amplitude. If  $\underline{r}_i$  is the position vector of the proton B relative to the centre of mass of the system (A + E), then

$$\tau_{if} = \left\langle \phi_f(\underline{r}) e^{i\underline{k}_f \cdot \underline{r}_i} \left| \frac{1}{s} - \frac{1}{R} \right| \Psi_i^+(\underline{r}, \underline{r}_i) \right\rangle, \quad (1.32)$$

where  $\Psi_i^+$  is the solution of the complete hamiltonian with asymptotic behaviour

$$\Psi_i^+ \underset{r_i \rightarrow \infty}{\sim} \phi_i(\underline{r}) e^{i\underline{k}_i \cdot \underline{r}_i} + \text{Outgoing waves} \quad (1.33)$$

We write  $\Psi_i^+$  in the form

$$\Psi_i^+ = \sum_j e^{i\underline{k}_i \cdot \underline{r}_i} \phi_j(\underline{r}) f_j(\underline{r}, \underline{r}_i), \quad (1.34)$$

and suppose that  $\underline{k}_i$  is sufficiently large for small - angle scattering only to occur and

$$|\underline{k}_i| = \mu v \simeq |\underline{k}_f| \gg \sqrt{2mE_{if}} \quad (1.35)$$

Choose  $\underline{k}_i$  along the Z axis of the cartesian co-ordinates

(X, Y, Z) of  $\underline{r}_i$ , and let  $(-k_f, \theta, \phi)$  be the spherical polar co-ordinates of  $k_f$  in the same frame. Then

$$(\underline{k}_i - \underline{k}_f) \cdot \underline{r}_i = -(k_i - k_f \cos \theta) Z - k_f \sin \theta (X \cos \phi + Y \sin \phi) \quad (1.36)$$

$\theta$  is small, and we may write

$$k_i - k_f = \frac{k_i^2 - k_f^2}{k_i + k_f} \approx \frac{E_{if}}{v} \quad (1.37)$$

so that (1.36) becomes

$$(\underline{k}_i - \underline{k}_f) \cdot \underline{r}_i = -\frac{E_{if} z}{v} - \mu v \theta (X \cos \phi + Y \sin \phi) \quad (1.38)$$

We may write  $\underline{e} = \hat{i}X + \hat{j}Y$  and put

$$\underline{\eta} = \mu v \theta (\hat{i} \cos \phi + \hat{j} \sin \phi) \quad \text{which satisfies} \quad \underline{\eta} \cdot \underline{v} = 0.$$

We then obtain

$$\begin{aligned} T_{if}(\underline{e}) = & \sum_j d\underline{r}_i d\underline{r}_j \phi_f^* \phi_j \exp(iE_{fj} \frac{z}{v} - i\underline{\eta} \cdot \underline{e}) \\ & \times v^{\frac{1}{2}} \mathcal{Y}_j(\underline{r}, \underline{r}_i) \end{aligned} \quad (1.39)$$

Now

$$\Phi = \frac{\mu^2}{4\pi^2} \int_0^{2\pi} \int_0^\pi |T_{if}(\theta, \phi)|^2 \sin \theta d\theta d\phi \quad (1.40)$$



and  $\eta = \mu v \Theta$ , so

$$Q = \frac{1}{4\pi^2} \int_0^{2\pi} d\phi \int_0^{\pi\mu v} \eta d\eta \left| \frac{1}{v} T_{if} \left( \frac{\eta}{\mu v}, \phi \right) \right|^2 \quad (1.41)$$

Thus, since  $\mu$  is large, we have

$$Q = \frac{1}{4\pi^2} \int_0^\infty d\eta \int_0^{2\pi} \left| \lim_{\mu \rightarrow \infty} \frac{1}{v} T_{if} \left( \frac{\eta}{\mu v}, \phi \right) \right|^2 \eta d\phi \quad (1.42)$$

This is the same as (1.29) provided

$$\lim_{\mu \rightarrow \infty} T_{if} = R(\eta/v), \quad (1.43)$$

and this condition is satisfied in general if  $\mathcal{F}_j(\underline{r}, \underline{r}_i)$  converges uniformly to  $F_j(\underline{r}', t)$  as  $\mu \rightarrow \infty$ . In particular, this establishes the equivalence of the first Born approximation and the first order impact parameter method, for in that case

$$\mathcal{F}_j(\underline{r}, \underline{r}_i) = F_j(\underline{r}', t) = \delta_{ij}.$$

#### § 1.4 Previous calculations employing the first - order impact parameter method

Detailed calculations for the processes

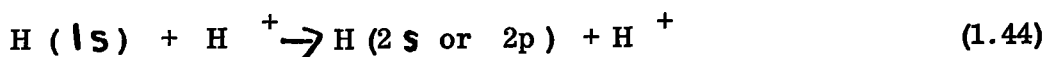

and

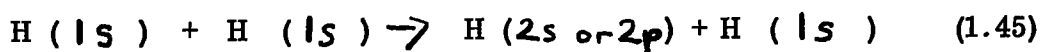

have been performed by Bates (1958), using the first - order impact parameter method.

The transition amplitudes concerned may readily be expressed in terms of modified Bessel functions of the second kind. For example, for proton excitation

$$a_{1s,2s} = \frac{2 e^2 v^{13/2}}{3^2 (1+16v^2)} K_2 \left( \frac{3e}{8v} \{1+16v^2\}^{1/2} \right) \quad (1.46)$$

(This transition amplitude is evaluated in detail by Bates (1961), page 256). Bates found that, as would be expected, distant collisions are relatively more important for high velocities of relative motion than for low velocities of relative motion, for the optically allowed  $S \rightarrow p$  transitions than for the optically forbidden  $S \rightarrow s$  transitions, and for ion - atom collisions than for atom - atom collisions. His calculated transition probabilities were used to estimate  $P(Z_M)$  for the process (1.44). If we suppose that Born's approximation is good for  $P < 0.1$  and bad for  $P > 0.5$ , his results show that for proton impact Born's approximation should be accurate for impact energies greater than 200 Kev and unreliable for energies below 50 Kev.

Bell (1961) has carried out a similar study of



and

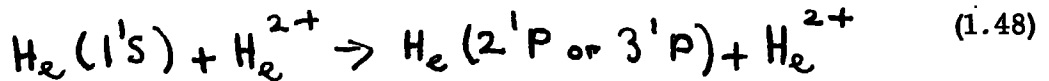

and Bell and Skinner (1962) studied

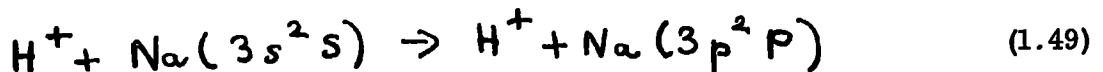

The excitation probabilities for processes (1.47) and (1.48) are all small ( $\leq 0.03$  for proton impact and  $0.08$  for alpha particle impact), but for process (1.49) which is a strong transition, they exceed unity for  $\rho$  less than  $\lambda^{\text{about}} 5a_0$ . Replacing  $P(\rho)$  by  $0.5$  whenever it exceeded  $0.5$  gave cross-sections in better accord with higher order approximations in this case. The method, however, cannot be expected to give good results for process (1.49) since it ignores back-coupling, which is of particular importance in strong transitions.

## CHAPTER 2

### Collisional excitation of helium in the impact parameter method

#### § 2.1

#### Introduction.

We use the first order impact parameter method (c.f. Chapter I) to calculate cross - sections for the processes

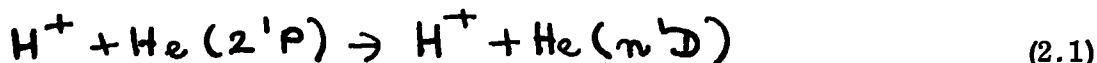

for  $n = 3, 4$  in the energy range 25 - 375 Kev. Cross - sections for electron excitation of the same states may be estimated, since these cross - sections are close to those for protons of the same velocity when the electron energy is above ten times threshold.

The cross - sections for process (2.1) will be compared with those obtained using the same wave-functions by Stauffer and Mc Dowell (1966), who employ the impact parameter method with a cut - off. (See Chapter III).

The wave formulation of Born's approximation has been used by Fox (1966) to calculate cross - sections for electron excitation of  $He(1^1S)$

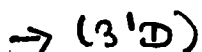

His results lie more than a factor of two

below the experimental data (Gabriel and Heddle (1960), Heddle and Lucas (1963), St. John et. al. (1964)), which agree among themselves to within 30%. Fox found that coupling with  $3^1P$  as an intermediate state was un-

important but, according to Somerville (1963), coupling to  $2^1 P$  may be of importance. In our treatment we ignore this coupling. Fox also shows that using the "velocity" formulation of the matrix element instead of the "length" formulation (which is equivalent if exact wave functions are used) may change the resulting cross - sections by 50% if approximate wave functions are used. This is because the "velocity" formulation gives greater weight to smaller radial distances, since it involves derivatives of the wave functions.

## § 2.2 Theory

The cross - section for excitation from an initial state  $i$  to a final state  $F$  is

$$Q_{if}(v) = 2 \int_0^{\infty} P_{if}(\rho, v) \rho \, d\rho \quad (\pi a_0^2) \quad (2.3)$$

where  $P_{if}$  is the transition probability at impact velocity  $v$  and impact parameter  $\rho$ .

On averaging over initial ( $M_{Li}$ ) and summing over final ( $M_{Lf}$ ) substates, the theory of § 1.1 gives

$$\begin{aligned} P_{if} &= \frac{N^2}{(2L_i+1)} \sum_{M_{Li}, M_{Lf}} \left| \int_{-\infty}^{\infty} e^{i\rho v t} \langle L_f, M_{Lf} | V | L_i, M_{Li} \rangle dt \right|^2 \\ &= \frac{N^2}{(2L_i+1)} \sum_{M_{Li}, M_{Lf}} P_{if}(M_{Li}, M_{Lf}) \end{aligned} \quad (2.4)$$

where  $p = E_f$  is the energy defect,  $N$  the number of electrons in the outer shell of the target atom, and, since we suppose the  $|L, M_L\rangle$  form a complete orthogonal set, and are independent of  $\underline{R}$ ,

$$V = |R - \underline{r}_R|^{-1} \quad (2.5)$$

where  $\underline{r}_R$  is the position vector of any of the  $N$  equivalent atomic electrons.

The wave functions are chosen to be of the form

$$|1^1 S\rangle = \frac{1}{\sqrt{2}} \{ \psi_{1s}(\gamma, 1) \psi_{1s}(\delta, 2) + \psi_{1s}(\delta, 1) \psi_{1s}(\gamma, 2) \} \quad (2.6)$$

$$|2^1 P_{M_L}\rangle = \frac{1}{\sqrt{2}} \{ \psi_{1s}(2, 1) \psi_{2p_{m_L}}(1, 2) + \psi_{1s}(2, 2) \psi_{2p_{m_L}}(1, 1) \} \quad (2.7)$$

$$|N^1 D_{M_L}\rangle = \frac{1}{\sqrt{2}} \{ \psi_{1s}(2, 1) \psi_{nd_{m_L}}(1, 2) + \psi_{1s}(2, 2) \psi_{nd_{m_L}}(1, 1) \} \quad (2.8)$$

where  $\psi_{nlm_L}(Z, i)$  is the  $nlm_L$  hydrogenic wave function of effective nuclear charge  $Z$  for electron  $i$ . These helium wave functions satisfy the orthogonality condition, and are normalised to unity.  $\gamma$  and  $\delta$  are chosen from a variational calculation of the energy to be 2.14 and 1.19 respectively (Eckhart, 1930). This is the choice made by Fox, and the resulting ground state energy is within 1% of the observed value.

Wave function (2.6) may be interpreted as representing one electron in an inner orbit and the other in an outer orbit, the values of  $\gamma$  and  $\delta$  corresponding to a small negative shielding of the inner electron by the outer, and nearly complete shielding of the outer electron by the inner.

Wave functions (2.7) and (2.8) give even better approximations to the observed energies of the appropriate excited states than (2.6) does to the ground state energies. This is because the quantum defects for the excited states are very small, as can be seen in Table 2.1. We therefore expect the above choice of wave functions to be satisfactory for our calculations.

Since hydrogenic wave-functions are orthogonal, and using

$$\psi_{1s}(z, \zeta) = \frac{1}{\sqrt{\pi}} z^{3/2} e^{-z\tau_1} \quad (2.9)$$

$$\begin{aligned} \langle N'D M_L | V | 1'S \rangle &= \frac{1}{2} \sum_{\delta, \delta'} \frac{2^{9/2} \delta^{3/2}}{(\delta+2)^3} \int \psi_{nd}^*(1, \tau_1) \frac{1}{|R-\tau_1|} \psi_{1s}(\delta, \tau_1) d\tau_1 \\ &= \sum_{\delta, \delta'} \frac{2^{9/2} \delta^{3/2}}{(\delta+2)^3} V_{1n}^{(\delta)} \end{aligned} \quad (2.10)$$

and

$$\begin{aligned} \langle N'D M_L | V | 2'P \rangle &= \frac{1}{2} \int \psi_{nd}^*(1, \tau_1) \frac{1}{|R-\tau_1|} \psi_{2p}(1, \tau_1) d\tau_1 \\ &= V_{2n}^{(1)} \end{aligned} \quad (2.11)$$

TABLE 2.1

Quantum defects for the helium atom states concerned in this chapter.

They are calculated from the energy levels given by Moore (1949) taking the Rydberg constant

$$R_H = 109737.31 \text{ cm}^{-1}$$

Atomic level	quantum defect
1 <sup>1</sup> S	0.256
2 <sup>1</sup> P	-0.0093
3 <sup>1</sup> D	0.0022
4 <sup>1</sup> D	0.0032

$V_{if}^{(z)}$  may be transformed by the Fourier involution theorem to

$$V_{if}^{(z)} = \frac{1}{2(2\pi)^3} \int e^{i\mathbf{k}\cdot\mathbf{R}} f(\mathbf{k}) g_{if}(z, \mathbf{k}) d\mathbf{k} \quad (2.12)$$

where  $f(\mathbf{k}) = \int \frac{e^{i\mathbf{k}\cdot\mathbf{R}}}{R} dR = \frac{4\pi}{k^2}$  (2.13)

and  $g_{if}(z, \mathbf{k}) = \int e^{-i\mathbf{k}\cdot\mathbf{r}} \psi_{nd}^*(\mathbf{r}) \psi_i(z, \mathbf{r}) d\mathbf{r}$  (2.14)

where we have dropped the suffix on  $\mathbf{r}$  for convenience.

Let  $(\theta, \phi)$  and  $(\beta, \alpha)$  be the polar angles of  $\mathbf{r}$  and  $\mathbf{k}$  respectively in the frame  $Oxyz$  (defined in Chapter I), and let  $(\Theta, \Phi)$  be the polar angles of  $\mathbf{r}$  in a frame  $\Sigma'$  with  $z$  axis along  $\hat{\mathbf{K}}$ . Thus in frame  $\Sigma'$

$$\mathbf{k} \cdot \mathbf{r} = k r \cos \Theta \quad (2.15)$$



Now

$$\psi_{ndm_2}^*(r, \theta, \phi) = R_{nd}(r) Y_{2m_2}^*(\theta, \phi) \quad (2.16)$$

$$\psi_{2pm_1}(r, \theta, \phi) = R_{2p}(r) Y_{1m_1}(\theta, \phi) \quad (2.17)$$

and (Edmonds, 1957)

$$Y_{lm}(\theta, \phi) = \sum_{m'} e^{im'\alpha} d_{m'm}^{(l)}(\beta) Y_{lm'}(\theta, \Phi) \quad (2.18)$$

where  $d_{m'm}^{(l)}(\beta)$  is a matrix element of the operator  $\mathcal{D}(\alpha, \beta, \gamma)$  which rotates  $\Sigma'$  into  $Oxyz$ , defined in Edmonds, Chapter 4.

The following quoted results also come from Edmonds.

We evaluate first  $g_{if}$  for transitions (2.1). Using (2.17) and (2.18) in (2.14) gives

$$g_{2n}(k) = \sum_{m_1', m_2'} e^{i\alpha(m_1' - m_2')} d_{m_1', m_1}^{(1)}(\beta) d_{m_2', m_2}^{(2)}(\beta) \times \int e^{i\mathbf{k} \cdot \mathbf{r}} R_{2p} R_{nd} Y_{1m_1}(\theta, \Phi) Y_{2m_2}^*(\theta, \Phi) d\tau \quad (2.19)$$

The integral over  $\Phi$  is

$$\int e^{i(m_1' - m_2')\Phi} d\Phi \quad (2.20)$$

which is zero unless  $m_1' = m_2'$  Also

$$Y_{2m_1'}^* = (-1)^{m_2'} Y_{2,-m_1'} \quad (2.21)$$

and

$$Y_{2,-m_1'}(\Theta, \Phi) Y_{1,m_1'}(\Theta, \Phi) = \sum_{\ell, m} \left[ \frac{15}{4\pi} (2\ell+1) \right]^{\frac{1}{2}} \begin{pmatrix} 1 & 2 & \ell \\ m_1' & -m_1' & m \end{pmatrix} Y_{\ell m}^*(\Theta, \Phi) \begin{pmatrix} 1 & 2 & \ell \\ 0 & 0 & 0 \end{pmatrix} \quad (2.22)$$

The Wigner 3 - j co-efficients in (2.22) will be non-zero only if

$$(i) \quad m = m_1' - m_1' = 0$$

and (ii) 1, 2,  $\ell$  obey the triangle inequalities, and  $1+2+\ell$  is even ;

that is  $\ell = 1$  or  $3$ .

We now have, using (2.15),

$$g_{2m}(\underline{k}) = 2\pi \sum_{m_1', \ell} (-1)^{m_1'} d_{m_1', m_1}^{(1)}(\beta) d_{m_1', m_2}^{(2)*}(\beta) \times \int_0^\infty R_{2p} R_{nd} r^2 dr \left[ \frac{15(2\ell+1)}{4\pi} \right]^{\frac{1}{2}} \begin{pmatrix} 1 & 2 & \ell \\ 0 & 0 & 0 \end{pmatrix} \begin{pmatrix} 1 & 2 & \ell \\ m_1' & -m_1' & 0 \end{pmatrix} \times \int_{-1}^1 e^{-i\mathbf{k}\cdot\mathbf{r}\cdot\boldsymbol{\omega}} Y_{\ell 0}^*(\Theta) d\omega$$

(2.23)

where  $\omega = \cos \theta$  Integrating over  $\omega$  and summing over  $\ell$  gives

$$g_{2n}(k) = i \sqrt{15} \sum_{m_1'} (-1)^{m_1'} d_{m_1' m_1}^{(1)}(\beta) d_{m_1' m_2}^{(2)}(\beta) \\ \times \left\{ -\frac{6}{5} \left[ (1+m_1')! (1-m_1')! (2+m_1')! (2-m_1')! T_{2n}^{(3)}(1, k) \right. \right. \\ \left. \left. - \frac{(-1)^{-m_1'}}{5} (4-m_1')^{\frac{1}{2}} T_{2n}^{(1)}(1, k) \right] \right\}$$

(2.24)

where

$$T_{\ell f}^{(s)}(z) = \int_0^{\infty} j_s(k\tau) R_{n_i} e_i(z, \tau) R_{n_f} e_f(\tau) \tau^2 d\tau \quad (2.25)$$

and we have used the fact that the  $d_{m'm}^{(j)}$  are real. Summing over

$m_1'$  ( $|m_1'| \leq 1$ ) gives finally

$$g_{2n} = -i \sqrt{\frac{3}{5}} \left\{ 2 \alpha_{m_1, m_2} T_{2n}^{(1)} + 3 \beta_{m_1, m_2} T_{2n}^{(3)} \right\} \quad (2.26)$$

where

$$\alpha_{m_1, m_2} = d_{0m_1}^{(1)} d_{0m_2}^{(2)} \\ + \frac{\sqrt{3}}{2} (d_{-1m_1}^{(1)} d_{-1m_2}^{(2)} + d_{1m_1}^{(1)} d_{1m_2}^{(2)}) \quad (2.27)$$

and

$$\beta_{m_1, m_2} = d_{0m_1}^{(1)} d_{0m_2}^{(2)} \\ - \frac{1}{\sqrt{3}} (d_{-1m_1}^{(1)} d_{-1m_2}^{(2)} + d_{1m_1}^{(1)} d_{1m_2}^{(2)}) \quad (2.28)$$

Now consider the transitions (2.2). Using (2.16) and (2.18) in

$$(2.14), \quad g_{1m}(\delta, \underline{k}) = \frac{1}{2\sqrt{\pi}} \sum_{m'} e^{im'\alpha} d_{m'm_2}^{*(2)}(\beta) \\ \times \int e^{-iK\tau\omega} R_{1s}(\delta, \tau) R_{nd}(\tau) Y_{2m'}^*(\Theta, \Phi) \tau^2 d\tau d\omega d\Phi \quad (2.29)$$

and the integral over  $\Phi$  vanishes unless  $m' = 0$ . On integrating over the angles we then obtain

$$g_{1m}(\delta, \underline{k}) = -\sqrt{5} d_{0m_2}^{(2)}(\beta) T_{1m}^{(2)}(\delta, \underline{k}) \quad (2.30)$$

The values of  $d_{m'm}^{(s)}(\beta)$  for  $s = 1, 2$  are given in tables 2.3 and 2.4 respectively, and the  $T_{lf}^{(s)}$  required are given in table 2.2.

TABLE 2.2

Some values of  $T_{lf}^{(s)}(z, \underline{k})$

In this table  $a = 5/6$ ,  $b = 3/4$ ,  $\phi_\delta = \delta + \frac{1}{n}$

	$n=3$	$n=4$
$T_{2n}^{(1)}(1, \underline{k})$	$\frac{40K(5a^2 - 3K^2)}{3^5 \sqrt{5} (\omega^2 + K^2)^5}$	$\frac{5K(b^4 + 6b^2K^2 - 3K^4)}{2^4 \sqrt{30} (b^2 + K^2)^6}$

	<u><math>n = 3</math></u>	<u><math>n = 4</math></u>
$T_{1n}^{(2)}(\delta, k)$	$\frac{2^7 \delta^{3/2} k^2 \phi_\delta^4}{3^3 \sqrt{30} (\phi_\delta^2 + k^2)^4}$	$\frac{\delta^{3/2} k^2 \{12\phi_\delta (\phi_\delta^2 + k^2) + k^2 - 7\phi_\delta^2\}}{2^3 (\phi_\delta^2 + k^2)^5}$
$T_{2n}^{(3)}(l, k)$	$\frac{64 \sqrt{5} k^3}{3^5 (a^2 + k^2)^4}$	$\frac{5 k^5}{\sqrt{30} (b^2 + k^2)^6}$

TABLE 2.3

$d_{m'm}^{(1)}(\beta)$

$m' \backslash m$	+1	0	-1
+1	$\frac{1}{2} (1 + \cos \beta)$	$\frac{1}{\sqrt{2}} \sin \beta$	$\frac{1}{2} (1 - \cos \beta)$
0	$-\frac{1}{\sqrt{2}} \sin \beta$	$\cos \beta$	$\frac{1}{\sqrt{2}} \sin \beta$
-1	$\frac{1}{2} (1 - \cos \beta)$	$-\frac{1}{\sqrt{2}} \sin \beta$	$\frac{1}{2} (1 + \cos \beta)$

TABLE 2.4

$$d_{m'm}^{(2)}(\beta)$$

$m' \backslash m$	-2	-1	0	1	2
-2	$\frac{1}{4}(1+\cos\beta)^2$	$-\sin\beta \cos^2\frac{\beta}{2}$	$\frac{1}{2}\sqrt{\frac{3}{2}} \sin^2\beta$	$-\sin\beta \sin^2\frac{\beta}{2}$	$\sin^4\frac{\beta}{2}$
-1	$\sin\beta \cos^2\frac{\beta}{2}$	$\frac{1}{2}(\cos\beta + \cos 2\beta)$	$-\frac{1}{2}\sqrt{\frac{3}{2}} \sin 2\beta$	$\frac{1}{2}(\cos\beta - \cos 2\beta)$	$-\sin\beta \sin^2\frac{\beta}{2}$
0	$\frac{1}{2}\sqrt{\frac{3}{2}} \sin^2\beta$	$\frac{1}{2}\sqrt{\frac{3}{2}} \sin 2\beta$	$\frac{1}{2}(3\cos^2\beta - 1)$	$-\frac{1}{2}\sqrt{\frac{3}{2}} \sin 2\beta$	$\frac{1}{2}\sqrt{\frac{3}{2}} \sin^2\beta$
1	$\sin\beta \sin^2\frac{\beta}{2}$	$\frac{1}{2}(\cos\beta - \cos 2\beta)$	$\frac{1}{2}\sqrt{\frac{3}{2}} \sin 2\beta$	$\frac{1}{2}(\cos\beta + \cos 2\beta)$	$-\sin\beta \cos^2\frac{\beta}{2}$
2	$\sin^4\frac{\beta}{2}$	$\sin\beta \cos^2\frac{\beta}{2}$	$\frac{1}{2}\sqrt{\frac{3}{2}} \sin^2\beta$	$\sin\beta \cos^2\frac{\beta}{2}$	$\frac{1}{4}(1+\cos\beta)^2$

Table 2.3 is quoted from Edmonds, p 57. Note the symmetry relations

between the  $d_{m'm}^{(s)}$ .

$$d_{m'm}^{(s)}(\beta) = (-1)^{m'-m} d_{-m'-m}^{(s)}(\beta)$$

$$d_{m'm}^{(s)}(\beta) = (-1)^{m'-m} d_{mm'}^{(s)}(\beta)$$

Let

$$b_{if} = \frac{1}{2\pi^2} \int_{-\infty}^{\infty} e^{i\mathbf{k}\cdot\mathbf{r}} \int \frac{e^{i\mathbf{k}\cdot\mathbf{R}}}{k^2} g_{if} d\mathbf{k} dt, \quad (2.31)$$

so that the transition probability for transitions (2.1) is

$$P_{2m} = \frac{1}{3} \sum_{m_1, m_2} |b_{2m}|^2 \quad (2.32)$$

and that for transitions (2.2) is

$$P_{lm} = \sum_{m_2} \sum_{\delta, \delta'} \frac{2^{\delta} \delta^3}{(\delta+2)^6} |Q_{lm}|^2 \quad (2.33)$$

To evaluate the  $b_{if}$  we note that in the  $Oxyz$  frame, since

$$\underline{R} = \underline{r} + \underline{v}t \quad \text{and } \underline{v} \text{ lies along the } z \text{ axis,}$$

$$\underline{k} \cdot \underline{R} = k_x r + k_z z \quad (2.34)$$

and choose the origin of time so that

$$z = -vt \quad (2.35)$$

Since

$$\int_{-\infty}^{\infty} e^{-\frac{i p z}{v} + i k_z z} dz = \delta(k_z - \chi) \quad (2.36)$$

putting  $\chi = p/v$ , we have

$$b_{if} = \frac{1}{\pi v} \int_{-\infty}^{\infty} dk_x \int_{-\infty}^{\infty} dk_y \frac{e^{i k_x r}}{k_0^2} g_{if}(k_0) \quad (2.37)$$

where

$$k_0^2 = k_x^2 + k_y^2 + \chi^2 \quad (2.38)$$

(2.37) is even in  $k_x$  and  $k_y$ , so

$$b_{if} = \frac{4}{\pi\sigma} \int_0^\infty dk_x \int_0^\infty dk_y \frac{\cos k_{oc} \rho}{k_o^2} g_{if}(k_o) \quad (2.39)$$

Since

$$\cos \beta = \frac{\chi}{k_o}, \quad \sin \beta = \frac{(k_x^2 + k_y^2)^{\frac{1}{2}}}{k_o} \quad (2.40)$$

the  $d_{m'm}^{(s)}(\beta)$  may be written in terms of  $k_o^2$

From Table 2.4 and (2.40) we have

$$d_{00}^{(2)}(\beta) = \frac{1}{2k_o^2} (2\chi^2 - k_{oc}^2 - k_y^2)$$

$$d_{01}^{(2)}(\beta) = -d_{0-1}^{(2)}(\beta) = \sqrt{\frac{3}{2}} \chi \frac{(k_{oc}^2 + k_y^2)^{\frac{1}{2}}}{k_o^2} \quad (2.41)$$

$$d_{02}^{(2)}(\beta) = +d_{0-2}^{(2)}(\beta) = \frac{1}{2} \sqrt{\frac{3}{2}} \frac{(k_{oc}^2 + k_y^2)}{k_o^2}$$

Hence, by multiplying together the appropriate terms from (2.41) and

and  
table 2.2, using (2.30) in (2.39) we have expressions for all the

$b_{13}^{0,m_2}, b_{14}^{0,m_2}$  in terms of a double integral over  $k_{oc}$  and  $k_y$

We obtain similar expressions for the  $b_{23}^{m_1,m_2}$  and  $b_{24}^{m_1,m_2}$

in terms of functions  $h_{m_1,m_2}$  and  $k_{m_1,m_2}$  where

$$g_{23}^{m_1,m_2} = \frac{-16ik}{3^5(a^2+k^2)^5} h_{m_1,m_2} \quad (2.42)$$



$$g_{24}^{m_1, m_2} = \frac{-iK}{8(K^2 + b^2)^6} h_{m_1, m_2} \quad (2.43)$$

and  $h_{m_1, m_2}$ ,  $k_{m_1, m_2}$  are given in Tables 2.5 and 2.6 respectively. Then

$$b_{23}^{m_1, m_2} = \frac{-64i}{3^5 \pi^2 \nu} \int_0^\infty dK_x \int_0^\infty \frac{dk_y}{K_0} \frac{h_{m_1, m_2} \cos(K_x \rho)}{(a^2 + K_0^2)^5} \quad (2.44)$$

and

$$b_{24}^{m_1, m_2} = \frac{-i}{2\pi^2 \nu} \int_0^\infty dK_x \int_0^\infty \frac{dk_y}{K_0} \frac{k_{m_1, m_2} \cos(K_x \rho)}{(K_0^2 + b^2)^6} \quad (2.45)$$

where  $a = \frac{5}{6}$ ,  $b = \frac{3}{4}$ .

TABLE 2.5

$\underline{\underline{R_{m_1, m_2}}}$

$\frac{m_1}{m_2}$	-1	0	+1
-2	$\frac{3}{2K_0} (K_x^2 + K_y^2)^{\frac{1}{2}} \{5a^2 - K_x^2 - K_y^2 - 11\chi^2\}$	$\frac{15\sqrt{2}\chi}{K_0} (K_x^2 + K_y^2)$	$-R_{-1,2}$
-1	$\frac{3\chi}{2K_0} \{5a^2 + 9K_x^2 + 9K_y^2 - 11\chi^2\}$	$\frac{3(K_x^2 + K_y^2)^{\frac{1}{2}} \{5a^2 - 11K_x^2 - 11K_y^2 + 29\chi^2\}}{2\sqrt{2}K_0}$	$R_{-1,1}$
0	$\frac{-1}{2K_0} \frac{\sqrt{3}}{\sqrt{2}} (K_x^2 + K_y^2)^{\frac{1}{2}} \{5a^2 + 9K_x^2 + 9K_y^2 - 51\chi^2\}$	$\frac{\sqrt{3}\chi}{K_0} \{5a^2 - 21K_x^2 - 21K_y^2 + 9\chi^2\}$	$-R_{-1,0}$
1	$\frac{-30\chi}{K_0} (K_x^2 + K_y^2)$	$-R_{0,-1}$	$R_{-1,-1}$
2	$\frac{15}{K_0} (K_x^2 + K_y^2)^{3/2}$	$R_{0,-2}$	$-R_{-1,-2}$

§ 2.3 Results and discussion

The units of  $\nu$  were changed to rydbergs, and the cross - sections were evaluated over a wide range of values of  $V (= 2\nu)$ , where  $V^2$  is the incident energy (in rydbergs for electron impact, but in units of 25 Kev for proton impact). In evaluating the

TABLE 2.6

$\rho_{m_1, m_2}$

$b = 3/4$ .

$m_1$ $m_2$	-1	0	1
-2	$\frac{1}{2} \sqrt{\frac{3}{2}} \frac{(k_x^2 + k_y^2)^{3/2}}{k_0} \{b^4 + 6b^2 k_0^2 + k_0^4 - 20k_0^2 \chi^2\}$	$10\sqrt{3} k_0 \chi (k_x^2 + k_y^2)$	$-k_{-1,2}$
-1	$\frac{1}{2} \sqrt{\frac{3}{2}} \frac{\chi}{k_0} \{b^4 + 6b^2 k_0^2 + 21k_0^4 - 40k_0^2 \chi^2\}$	$\frac{\sqrt{3}}{4} \frac{(k_x^2 + k_y^2)^{3/2}}{k_0} \{b^4 + 6b^2 k_0^2 - 19k_0^4 + 80k_0^2 \chi^2\}$	$k_{-1,1}$
0	$-\frac{1}{4} \frac{(k_x^2 + k_y^2)^{3/2}}{k_0} \{b^4 + 6b^2 k_0^2 + 21k_0^4 - 120k_0^2 \chi^2\}$	$\frac{1}{\sqrt{2}} \frac{\chi}{k_0} \{b^4 + 6b^2 k_0^2 - 39k_0^4 + 60k_0^2 \chi^2\}$	$-k_{-1,0}$
1	$-10\sqrt{6} k_0 (k_x^2 + k_y^2) \chi$	$-k_{0,-1}$	$k_{-1,-1}$
2	$5\sqrt{6} k_0 (k_x^2 + k_y^2)^{3/2}$	$k_{0,-2}$	$-k_{-1,-2}$

but, difficulties arose due to the rapid oscillations of  $\cos(k_x \rho)$  for large  $k_x$  and  $\rho$ . These were minimised by changing the variables to  $X = k_x \rho$ ,  $Y = k_y \rho$ , and the integrals evaluated by using a double Gauss - Laguerre quadrature with  $(p, q)$  points, (the  $p$  referring to the integral over  $X$ ). In the worst case, convergence was obtained for  $(15, 10)$  points.

The final integration over the impact parameter was carried out using a 31 - point repeated Simpson, and the contributions from each  $(m_1, m_2)$  were added together. In tables 2.7 and 2.8 we give  $\rho |P_{if}(m_1, m_2)|^2$  for each  $(m_1, m_2)$  and varying  $\rho$  for the transitions  $2^1P \rightarrow 4^1D$  and  $1^1S \rightarrow 3^1D$  respectively at  $v^2 = 10$ . For  $1^1S \rightarrow n^1D$  significant contributions occur only for  $\rho < 5a_0$ , except for  $m_2 = 0$  when they arise from  $\rho < 7a_0$ . In the  $2^1P \rightarrow n^1D$  case, however, all  $(m_1, m_2)$  terms give significant contributions for  $\rho < 15a_0$ . The oscillations in some of the  $P_{if}(m_1, m_2)$  correspond to a change in sign of the corresponding matrix element.

In table 2.9 we compare our  $2^1P \rightarrow n^1D$  ( $n = 3, 4$ ) cross - sections with those of Stauffer and McDowell (1966) mentioned in the introduction. Considering the simplicity of the cut - off method, the two sets of results are in remarkably good

TABLE 2.7

$|P_{ij}^{(m_1, m_2)}|^2$  for the  $2^2P \rightarrow 4^1D$  transition at  $V^0 = 10$

$\rho^{(m_1, m_2)}$	$(-1, 2)$	$(-1, -1)$	$(-1, 0)$	$(-1, 1)$	$(-1, 2)$	$(0, -2)$	$(0, -1)$	$(0, 0)$
1	1.92, -5	2.16, -6	1.78, -4	6.46, -6	8.12, -4	3.23, -6	2.86, -4	3.68, -3
3	6.41, -3	3.76, -4	4.60, -3	3.28, -4	8.18, -3	1.64, -4	1.74, -5	1.31, -2
5	1.25, -2	8.34, -4	5.83, -3	2.46, -4	6.35, -3	1.23, -4	7.39, -4	2.60, -3
7	1.55, -2	1.24, -3	7.60, -3	2.64, -4	8.77, -3	1.32, -4	7.22, -4	4.56, -3
9	1.81, -2	1.59, -3	9.40, -3	3.49, -4	1.16, -2	1.75, -4	6.24, -4	7.56, -3
1.2	2.22, -2	1.98, -3	1.08, -2	4.51, -4	1.24, -2	2.25, -4	1.10, -3	6.14, -3
1.6	2.61, -2	2.26, -3	1.06, -2	4.44, -4	9.45, -3	2.22, -4	2.78, -3	9.31, -4
2.0	2.78, -2	2.37, -3	9.38, -3	3.54, -4	5.86, -3	1.77, -4	5.06, -3	5.46, -4
2.6	2.71, -2	2.36, -3	6.83, -3	2.00, -4	1.87, -3	9.99, -5	8.71, -3	9.71, -3
3.0	2.53, -2	2.26, -3	5.16, -3	1.14, -4	4.74, -4	5.70, -5	1.09, -2	2.01, -2
4.0	1.87, -2	1.86, -3	2.18, -3	5.84, -6	3.71, -4	2.92, -6	1.36, -2	4.43, -2
6.0	7.30, -3	1.07, -3	3.63, -4	4.08, -5	1.47, -3	2.04, -5	8.49, -3	3.78, -2
8.0	2.47, -3	6.17, -4	1.38, -4	4.18, -5	4.74, -4	2.09, -5	2.91, -3	1.29, -2
11.0	5.61, -4	2.87, -4	6.84, -5	8.36, -6	1.81, -5	4.18, -6	4.91, -4	1.73, -3
13.0	2.40, -4	1.69, -4	2.83, -5	1.94, -6	9.24, -6	9.71, -7	2.28, -4	8.15, -4
15.0	1.06, -4	9.53, -5	2.26, -6	6.60, -7	4.87, -5	3.30, -7	1.92, -4	9.56, -4

TABLE 2.8

$|P_{1j}^{(m_a)}|^2$  at  $V^2 = 10$  for  $1^1S \rightarrow 3^1D$  transition

$p / m_a$	0	1	2
.025	6.46,-9	7.18,-10	1.04,-8
.05	9.26,-7	4.71,-7	1.84,-6
.075	3.78,-6	5.64,-6	1.07,-5
.1	4.39,-6	1.76,-5	2.10,-5
.15	9.03,-7	4.03,-5	2.87,-5
.2	3.55,-8	4.91,-5	2.86,-5
.4	6.19,-7	5.97,-5	4.02,-5
.6	6.92,-7	8.17,-5	5.36,-5
.8	2.32,-6	9.68,-5	5.49,-5
1.0	5.71,-6	1.01,-4	4.90,-5
1.25	1.20,-5	9.57,-5	3.74,-5
1.5	1.98,-5	8.29,-5	2.51,-5
1.75	2.77,-5	6.70,-5	1.48,-5
2	3.47,-5	5.08,-5	7.57,-6
2.5	4.24,-5	2.45,-5	8.71,-7
3	4.17,-5	9.09,-6	7.30,-8
4	2.72,-5	1.47,-7	1.49,-6
5	1.31,-5	6.57,-7	1.36,-6
6	5.44,-6	1.36,-6	7.06,-7
7	1.99,-6	4.29,-6	2.66,-7
8	6.30,-7	9.38,-7	6.03,-8
9	1.33,-7	5.82,-7	1.15,-10

TABLE 2.9

Cross - sections ( $\pi a_0^2$ ) for proton impact excitation of  
the  $2^1 P \rightarrow n^1 D$  transitions

(a) this paper      (b) Stauffer and McDowell (1966)

E (Kev)	$3^1 D$		$4^1 D$	
	(a)	(b)	(a)	(b)
31.25	10.3	6.1	1.64	1.11
62.5	5.69	4.1	8.71, -1	8.2, -1
93.8	3.91	3.0 <sub>5</sub>	5.93, -1	6.3, -1
125	2.97	2.4 <sub>6</sub>	4.50, -1	5.2, -1
188	2.01	1.7 <sub>6</sub>	3.03, -1	4.0, -1
250	1.52	1.3 <sub>7</sub>	2.38, -1	3.2, -1

TABLE 2.10

Cross sections ( $\pi a_0^2$ ) for proton and electron impact excitation  
of the  $1^1 S \rightarrow n^1 D$  transitions

Electron energy (Ryd)	2.09	3.25	4.60	5.85	10.85	15.85
E (Kev)	31.25	62.5	93.8	125	250	375
Q ( $3^1 D$ )	3.55, -3	3.24, -3	2.69, -3	2.27, -3	1.39, -3	1.00, -3
Q ( $4^1 D$ )	1.87, -3	1.72, -3	1.43, -3	1.21, -3	7.33, -4	5.30, -4

(In both tables the figures following a comma indicate the power of ten by which that entry is to be multiplied.)



agreement.

The cross - sections for the  $1^1S - n^1D$  ( $n=3,4$ ) transitions are given in table 2.10. Their magnitude is controlled by the quadrupole matrix element which, in the quadrupole length representation, may be written as

$$R_{if}^{(2)} = \frac{4\pi N^2}{3} \sum_{\mu} |\langle \Psi_f | r^2 Y_{2\mu}(\frac{r}{r}) | \Psi_i \rangle|^2$$

Using

$$\langle i | \hat{F} | j \rangle = -\frac{i \hbar}{\Delta E_{ij}} \langle i | \frac{d\hat{F}}{dt} | j \rangle$$

where  $\hat{F}$  is any operator (Landau and Lifschitz 1962), we obtain the equivalent "quadrupole velocity" representation. Stauffer and McDowell (1964) found that  $R_{if}^{(2)}$  is quite sensitive both to the choice of the ground - state wave function and to the choice of the "length" or "velocity" representation. For the ground state wave function they write

$$\Psi_i = N_k \{ \exp -(a_k \tau_1 + b_k \tau_2) + \exp -(a_k \tau_2 + b_k \tau_1) \} \\ \times \{ 1 + c_k \tau_{12} \},$$

Choosing various sets of variational parameters. They also examine ( $k=2$ ) the analytic Hartree-Fock function of Roothaan et al, (1960). These together with the differences they give between the calculated and experimental ground state energy, are listed in table 2.11.

TABLE 2.11.

Wave functions and energies for H e  $[(ys)^2 1s]$

$$(\Delta E = E_{\text{exp}} - E^{(k)}_{\text{calc.}})$$

$k$	$a_k$	$b_k$	$c_k$	$\Delta E_k$ (a.u.)
1	$\frac{27}{16}$	$\frac{27}{16}$	0	0.05606
2	—	—	—	0.04204
3	2.18	1.19	0	0.02830
4	1.850	1.850	0.366	0.01260
5	1.436	2.208	0.292	0.00230

Note that  $k = 3$  corresponds to the wave-functions used in our calculations.

The quadrupole strengths obtained in the quadrupole length (Q.L) and quadrupole velocity (Q.V.) representations by using the ground state wave-functions of table 2.11 are given in table 2.12.

TABLE 2.12.

Quadrupole strengths ( $a_0^4$ )

$R$	Probable value of $R^{(2)}$	$R^{(2)}$ (Q.L.)	$R^{(2)}$ (Q.V.)
	0.062	$1^1S \rightarrow 3^1D$	
1		0.02090	0.03759
2		0.05471	0.05993
3		0.12934	—
4		0.02207	—
5		0.07139	0.06506
	0.032	$1^1S \rightarrow 4^1D$	
1		0.01107	0.01947
2		0.02701	0.02957
3		0.0650	—
5		0.03510	—

Because of these variations in  $R_{lf}^{(2)}$  our results must be regarded as uncertain by as much as a factor of two. A similar variation (from

- 0.086 to - 0.150 in the "length" formulation) occurs in the matrix element  $f(0)$  appearing in Fox's work (Fox 1966). In each case the chosen ground state wave function corresponds to the highest absolute calculated value of the matrix element concerned, in the "length" formulation.

For proton impact, there is no significant loss of accuracy in taking the final proton velocity to be  $v_f$ , but this is quite inappropriate in the electron impact case until very high initial velocities are reached. Instead, for a proton velocity  $v$  we choose an electron energy such that

$$v^2 = \frac{1}{2} (V_f^2 + V_i^2)$$

$$\text{and } W_i(\epsilon) = (v^2 + \frac{1}{2} E_{if}) \text{ ryd},$$

where  $V_f$  is the final velocity of the scattered electron. This cannot be an accurate procedure close to threshold, where our model is inadequate in any event, but should give more reliable electron - impact cross-sections for  $W_i > 5 E_{if}$ , say. In the electron impact case our  $1'S \rightarrow 3'D$  results at six times threshold energy are almost a factor of two higher than Fox's results, but they appear to join smoothly to a reasonable extrapolation of his curve at about fifteen times threshold.

In Figure 2.1 we compare our calculated values for  $Q(1'S \rightarrow 4'D)$  with recent experimental values of de Heer and v. d. Bos (1966). We also show on the graph two experimental values (obtained for electron impact) of Moustafa et. al. (de Heer, private communication). Allowing for the uncertainties in our computed

values the agreement with experiment is satisfactory. These values, however, lie a factor of two below the published electron impact measurements, supporting the suggestion that the published data is too high by perhaps as much as a factor of two.

FIG. 2-1

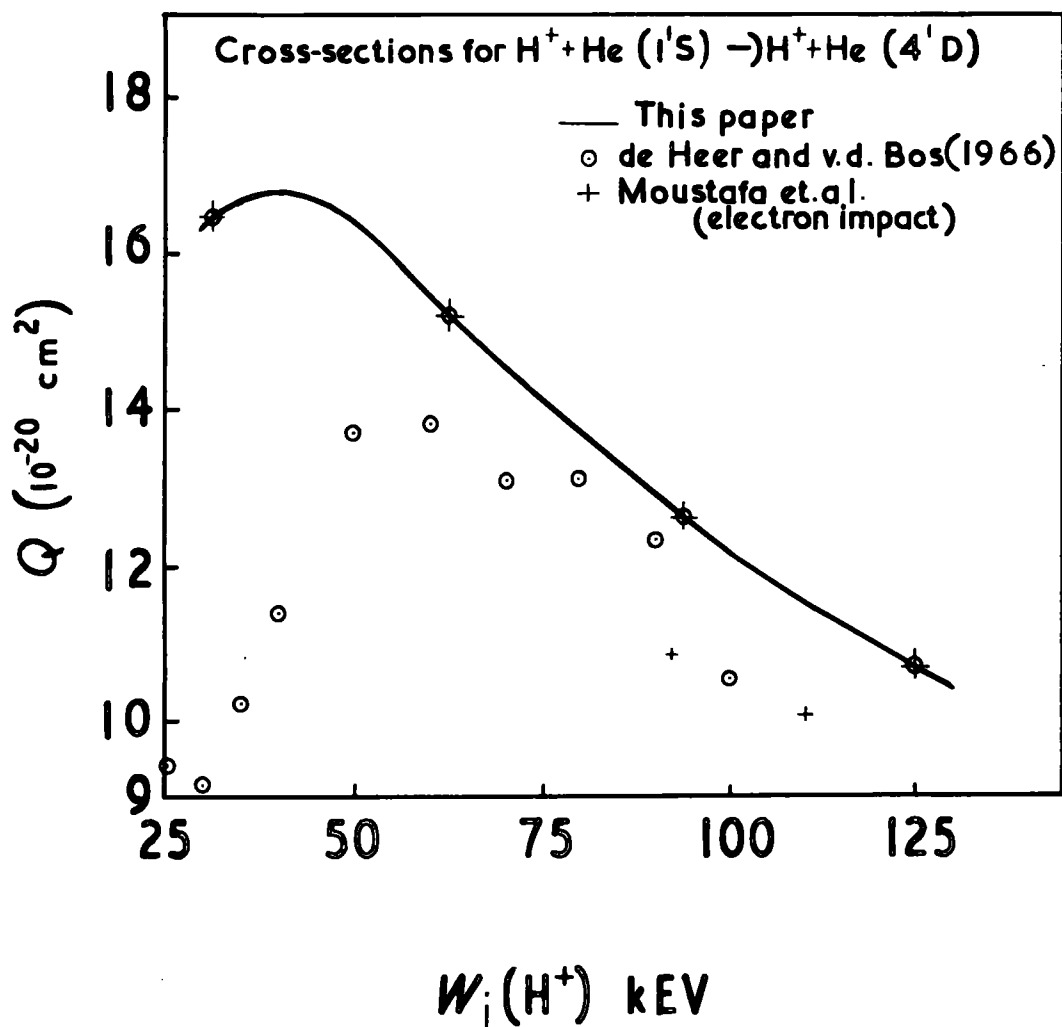

## CHAPTER III

### The first - order impact parameter method with cut-off

#### § 3.1

#### Introduction

In this chapter we review the work of Seaton (1962), Stauffer and McDowell (1965) and Stauffer and McDowell (1966) (hereafter referred to as papers A, B and C respectively), on the excitation of atoms by electron impact.

The first Born approximation, which is shown in § 1.3 to be equivalent to the first - order impact parameter method, is known to give correct results at high energies for non-rearrangement collisions, but at lower energies comparison with experiment shows that Born's Cross-sections are nearly always too large.

The physical assumptions made in Born's approximation (cf. Chapter I) will be valid at all energies for impact parameters  $\rho_i \geq \tau_\alpha$ , where  $\tau_\alpha$  is a length comparable with the atomic dimensions. At low impact energies, however, they will be invalid for  $\rho_i \leq \tau_\alpha$ . The equation (1.16) for the excitation cross-section thus includes appreciable contributions from the region where the approximation is invalid, and one might therefore think of introducing a cut - off in (1.16), to obtain

$$Q(i \rightarrow j) = 2\pi \int_{R_0}^{\infty} P_{ji}(\rho_i) \rho_i d\rho_i \quad (a_0^2) \quad (3.1)$$

for the cross-section for excitation from initial state  $i$  to final state  $j$ .

Here the cut-off  $R_0$  is of atomic dimensions, and is chosen to give agreement with Born's approximation in the limit of high energies.

In § 3.2 we give the theory of paper C for electron excitation of a general transition. A justification of the various approximations made in the method is given in § 3.3.

### § 3.2 General Theory

In the first - order impact parameter method, the transition probability for excitation from initial state  $i$  to final state  $j$  is, using the notation of Chapter I and II,

$$P_{ji} = \frac{N^2}{(2L_i + 1)} \sum_{\text{degenerate states}} \left| \int_{-\infty}^{\infty} e^{i\mathbf{p}\cdot\mathbf{r}} V_{ji} dt \right|^2 \quad (3.2)$$

where

$$V_{ji}(t) = \int \Psi_j^*(\underline{r}) \frac{1}{|\underline{R} - \underline{r}|} \Psi_i(\underline{r}) d\underline{r}, \quad (3.3)$$

$\underline{r}$  being the position vector of the excited atomic electron, and  $\Psi_i, \Psi_j$  are initial and final wave-functions of the target system.

Let  $\Sigma$  be the frame of reference with respect to which the co-ordinates of the system are defined. In the frame  $\Sigma$ , the  $z$  axis lies along  $\underline{v}_i$  and the  $x$  axis along  $\underline{\rho}_i$ . The internal wave functions of the target system are



defined with respect to a frame  $\Sigma'$  which is at some arbitrary orientation with respect to  $\Sigma$ , so that

$$\Psi_{\Sigma'}(\ell, S, J, M_j) = \sum_{M_j'} \mathcal{D}_{M_j', M_j}^{(j)}(\alpha, \beta, \gamma) \Psi_{\Sigma}(\ell, S, J, M_j'), \quad (3.4)$$

where  $\mathcal{D}_{m'm}^{(j)}(\alpha, \beta, \gamma)$  are the matrix elements of the rotation operator (Edmonds 1957).

Now expand

$$\frac{1}{|\underline{R} - \underline{r}|} = \sum_{\lambda} P_{\lambda}(\hat{\underline{R}} \cdot \hat{\underline{r}}) \frac{\tau_{\lambda}}{\tau_{\lambda+1}} \quad (3.5)$$

and put  $\tau_z = r$ ,  $\tau_{\lambda} = R = |\underline{r}_i + \underline{v}_i t|$

Then the transition probability from state

$|\ell_1, \ell_1, S_1, J_1, M_{j_1}\rangle$  to state  $|\ell_2, \ell_2, J_2, M_{j_2}\rangle$  is

$$P_{j_1 j_2}(\rho_i) = \frac{N^2}{(2\ell_1 + 1)} \sum_{\text{degenerate states}} \sum_{\substack{\lambda, \mu \\ \lambda', \mu'}} \sum_{\substack{M'_{j_1}, M'_{j_2} \\ M''_{j_1}, M''_{j_2}} \mathcal{D}_{M'_{j_1}, M_{j_1}}^{(j_1)} \mathcal{D}_{M'_{j_2}, M_{j_2}}^{(j_2)} \\ \mathcal{D}_{M''_{j_2}, M_{j_2}}^{(j_2)*} \mathcal{D}_{M''_{j_1}, M_{j_1}}^{(j_1)*} \frac{(4\pi)^2}{(2\lambda + 1)(2\lambda' + 1)} M^{\lambda \mu}(\ell_1, \ell_2, M'_{j_1}, M'_{j_2}) \\ \times M^{\lambda' \mu'}(\ell_1, \ell_2, M''_{j_1}, M''_{j_2}) T^{\lambda \mu} T^{\lambda' \mu'*} \quad (3.6)$$

where

$$M^{\lambda\mu}(J_1, J_2, M_{j_1}, M_{j_2}) = \langle \Gamma_2 L_2 S_2 J_2 M_{j_2} | Y_{\lambda\mu} | \Gamma_1 L_1 S_1 J_1 M_{j_1} \rangle \quad (3.7)$$

$$Y_{\lambda\mu} = r^\lambda Y_{\lambda\mu}(\theta, \phi) \quad \text{being a solid spherical harmonic}$$

operator. Hence, (Edmonds 1957)

$$M^{\lambda\mu} = (-1)^{J_2 - M_{j_2}} \begin{pmatrix} J_2 & \lambda & J_1 \\ -M_{j_2} & \mu & M_{j_1} \end{pmatrix} \langle \Gamma_2 J_2 || Y_{\lambda\mu}(\lambda) || \Gamma_1 J_1 \rangle \quad (3.8)$$

where the ~~final~~ matrix element  $\langle \Gamma_2 J_2 || Y_{\lambda\mu}(\lambda) || \Gamma_1 J_1 \rangle$  is independent of  $M_{j_1}$ ,  $M_{j_2}$ .

$$\text{Also } T^{\lambda\mu} = \int_{-\infty}^{\infty} \frac{e^{i\mu t}}{R^{\lambda+1}} Y_{\lambda\mu}(\Theta, 0) dt \quad (3.9)$$

$$\text{where } \cos \Theta = \frac{v_i t}{R}$$

On averaging over all possible orientations of  $\Sigma'$ ,

$$\bar{P}_{j_i}(\rho_i) = \frac{N^2 (4\pi)^2}{(2L_i+1)(2S_i+1)} \sum_{J_1, J_2} \sum_{\lambda, \mu} \frac{|T^{\lambda\mu}|^2}{(2\lambda+1)^3} |\langle \Gamma_2 J_2 || Y_{\lambda\mu}(\lambda) || \Gamma_1 J_1 \rangle|^2 \quad (3.10)$$

where it has been assumed that the degenerate states are those with all values of  $J$ ,  $M_j$  consistent with the given values of  $L$ ,  $S$ .

Using

$$|\Pi \langle L S J M_j \rangle| = \sum_{M_L M_S} |\Pi \langle L M_L S M_S \rangle \langle L M_L S M_S | \langle L S J M_j \rangle| \quad (3.11)$$

gives  $\bar{P}_{j_i}(\rho_i)$  in the  $(L M_L \quad S M_S)$  scheme as

$$\bar{P}_{j_i}(\rho_i) = \frac{N^2 (4\pi)^2}{(2L_i+1)} \sum_{\lambda \mu} \frac{|T^{\lambda \mu}|^2}{(2\lambda+1)^3} |\langle \Pi_2 L_2 || \underline{Y}_{\lambda} || \Pi_1 L_1 \rangle|^2 \quad (3.12)$$

where

$$\begin{aligned} & |\langle \Pi_2 L_2 || \underline{Y}_{\lambda} || \Pi_1 L_1 \rangle|^2 \\ &= |\langle \Pi_2 L_2 0 S_1 0 | \underline{Y}_{\lambda 0} | \Pi_1 L_1 0 S_1 0 \rangle|^2 \begin{pmatrix} L_1 & L_2 & \lambda \\ 0 & 0 & 0 \end{pmatrix}^2 \end{aligned} \quad (3.13)$$

The integral in (3.12) can be evaluated to give

$$|T^{\lambda \mu}(\rho_i)|^2 = \frac{2\lambda+1}{\pi v_i^2} \frac{K_{\mu}^2(\beta_i)}{(\lambda+\mu)!(\lambda-\mu)!} \left(\frac{\rho}{v_i}\right)^{2\lambda} \quad (3.14)$$

(See Appendix B of paper C)

$$\text{where } \beta_i = \frac{\rho_i \rho}{v_i} \quad (3.15)$$

Reciprocity must be satisfied : that is we require

$$\omega_i \bar{P}_{j_i}(\rho_i) = \omega_j \bar{P}_{i_j}(\rho_j) \quad (3.16)$$

where  $w_a$  is the statistical weight of level  $a$ , and  $\rho_j$  is the impact parameter of the incident particle velocity  $v_j$  in the time-reversed situation. Because energy and total angular momentum are conserved,  $\rho_j$  and  $v_j$  will differ from  $\rho_i$  and  $v_i$ . Since

$$|\langle \Gamma_2 L_2 || Y(\lambda) || \Gamma_1 L_1 \rangle|^2 = |\langle \Gamma_1 L_1 || Y(\lambda) || \Gamma_2 L_2 \rangle|^2,$$

the transition probabilities given by (3.12) will satisfy (3.16) if

$$|T^{\lambda\mu}(\beta_i)|^2 = |T^{\lambda\mu}(\beta_j)|^2$$

Let  $W_i = \frac{1}{2} m v_i^2$  and  $W_j = \frac{1}{2} m v_j^2$  be the initial and final energies of the incident electron, so that  $E_{ij} = W_j - W_i$ . Since  $E_{ij}$  is small (typically of the order of a few electron volts), we may replace  $W_i$  and  $W_j$  by  $W = \frac{1}{2} (W_i + W_j)$ , an approximation that will be valid except at low impact energies. We also assume that the initial and final orbital angular momenta of the incident electron are large compared with their difference, so that

$\rho_i v_i \simeq \rho_j v_j$ . This is valid for all incident energies if  $\rho_i \gg \bar{r}_i$ , the expectation value of the radius of the initial state, and at high energies of  $\rho_i \gg \bar{r}_i$ . Then reciprocity is satisfied if  $\beta_i$  and  $\beta_j$  are replaced by

$$\beta = \frac{1}{2} \sqrt{\frac{W_i}{I_H}} \left( \frac{|E_{ij}|}{W} \right) \left( \frac{\rho}{a_0} \right) \quad (3.17)$$

where  $I_H$  is the ionization potential of atomic hydrogen.

On integrating over impact parameters, the cross-section then becomes

$$\varphi(W_i) = \frac{64\pi N^2}{(2L_1+1)} \left(\frac{W}{W_i}\right) \left(\frac{I_H}{\Delta E_{ij}}\right)^2 \sum_{\lambda} \left(\frac{\Delta E_{ij}^2}{4I_H W}\right)^{\lambda} \\ \times \frac{|K_{\mu_2} \langle 2 || Y_{\lambda} || 1, \langle 1, 1 \rangle|^2}{a_0^{2\lambda} (2\lambda+1)^2} \sum_{\mu} \frac{\chi_{\mu}(\beta_0)}{(\lambda-\mu)!(\lambda+\mu)!} \quad (a_0^2) \quad (3.18)$$

where  $\Delta E_{ij} = |E_{ij}|$ ,

$$\chi_{\mu}(\beta_0) = \beta_0^2 \left\{ K'_{\mu}(\beta_0) - \left(1 + \frac{\mu^2}{\beta_0^2}\right) K_{\mu}(\beta_0) \right\} \quad (3.19)$$

and  $\beta_0$  is  $\beta$  with  $R$  replaced by the cut-off  $R_0$ .

If only terms with  $\lambda \leq 2$  are retained in the multipole expansion

(3.5), we obtain

$$\varphi(W_i) = \frac{N^2}{(2L_1+1)} \sum_0 \left\{ \frac{8}{3} \left(\frac{I_H}{W_i}\right) \left(\frac{R^{(1)}}{a_0^2}\right) \phi(\beta_0) \right. \\ \left. + \frac{2}{15} \left(\frac{\Delta E}{I_H}\right)^2 \left(\frac{I_H}{W W_i}\right) \left(\frac{R^{(2)}}{a_0^4}\right) \psi(\beta_0) \right\} \quad (\pi a_0^2) \quad (3.20)$$

where  $R^{(L)} = \frac{4\pi}{2L+1} \sum_{m=-L}^L |\psi_j| \pi^L Y_L^{lm}(\hat{r}) |\psi_i\rangle|^2$ ,

$$\phi(\beta) = \beta K_1(\beta) K_0(\beta)$$

and  $\psi(\beta) = \phi(\beta) + \frac{1}{2} K_1^2(\beta)$

This is the expression obtained in paper B, where it is used to calculate cross-sections for electric quadrupole transitions. If  $\Delta l = 1$ ,  $R^{(2)} = 0$  and (3.20) reduces to Seaton's expression for optically allowed transitions

### § 3.3 Justification of the method

In order for the introduction of a cut-off to be justified, a sizable contribution to the cross-section must come from impact parameters greater than the chosen cut-off  $R_0$ , and this is verified for  $\Delta l = 1$  and  $\Delta l = 2$  transitions in papers A and B respectively. A critical point is the sensitivity of the calculations to errors in the choice of  $R_0$ , and this is discussed in § 4.3. Above five times the energy transfer, we may obtain  $Q$  to within a factor of two even if there is an error of 25% in  $R_0$ , when  $\Delta l \leq 2$ , although if  $\Delta l > 2$  we would expect a greater sensitivity. For  $\Delta l = 1$ , Seaton suggests choosing  $R_0 = \bar{r}_i$  as a general procedure. This is also reasonably satisfactory in the  $\Delta l = 2$  case, but it takes no account of the final state distribution, and the authors of paper B suggest that a suitable weighted mean of  $\bar{r}_i$  and  $\bar{r}_j$  is more satisfactory. They adopt

$$\tau_0 = \frac{(2l_>+1)\bar{r}_< + (2l_<+1)\bar{r}_>}{(2l_>+1) + (2l_<+1)} \quad (3.21)$$

where  $l_<$  is the lesser and  $l_>$  the greater of the initial and final orbital angular momenta of the atom, with a similar definition of  $\bar{r}_<$  and  $\bar{r}_>$  in terms of the initial and final average radial distances of the atomic electron from the

nucleus. For the six  $\Delta l = 2$  transitions in hydrogen considered in paper B, the maximum error in  $R_0$  is less than 20% if  $R_0$  is chosen as  $\tau_\omega$ , while if  $R_0$  is chosen to be  $\bar{\tau}_l$  it can be as large as 60%. For  $\Delta l = 1$  transitions,  $r_\omega$  is a better approximation in about half the cases considered by Seaton but when it is worse, it tends to give errors of order 60%.

Seaton's justification of the subsidiary approximation of putting  $\tau_\lambda = \tau$  and  $\tau_\lambda = R$  is as follows. The product  $V(\epsilon) \Psi_j^* \Psi_i$  will be small for  $\tau \gg \bar{\tau}_l$ , where  $\bar{\tau}_l$  is defined above. Since  $R \gg \rho_i$ , the distance of closest approach, the replacement is justified if  $\rho_i \gg \bar{\tau}_l$ , implying that  $R_0$  is larger than  $\bar{\tau}_l$ . In fact, this approximation makes the introduction of a cut-off necessary, since  $\rho_j \rightarrow \infty$  as  $\rho_i \rightarrow 0$ . The approximation is less good for large  $\lambda$  than for small  $\lambda$ , but it should not be significantly worse for  $\lambda = 2$  than for  $\lambda = 1$  ( $\Delta l = 1$ ). It results in the  $\lambda = 0$  term in (3.5) giving a zero contribution to the probability, since  $\Psi_i$  and  $\Psi_j$  are orthogonal and independent of  $R$ . If this assumption were not made, the  $\lambda = 0$  term would give a non-zero contribution, and would be dominant in some cases. This would happen, in particular, when  $\Delta l = 0$ , since the angular parts of  $\Psi_i$ ,  $\Psi_j$  are then not orthogonal. Also calculations of  $R_0$  for  $\Delta l = 0$  transitions in paper B show that the criterion  $R_0 > \bar{\tau}_l$  is not satisfied, and so we cannot expect the method to give reliable results for these transitions.

### 3.4 Results and discussion

The methods described above yield cross - sectional formulae which are sufficiently simple to be used for the estimation of large numbers of cross-sections, and which give low energy cross-sections which are smaller than those obtained in Born's approximation. In particular, they enable us to estimate cross - sections between excited  $n\ell \rightarrow n'\ell'$  states of hydrogen to within a factor of two, provided  $\ell \neq \ell'$ . Because retaining all terms in the expansion (3.5) adds a positive amount to the probabilities, cross - sections obtained using (3.18) are higher than those obtained in papers A. and B. They still, however, lie lower than the Born approximation at low energies (c.f. Fig 4.3). The calculated results for  $\Delta\ell = 0$  using (3.20), and choosing  $R_0$  so that the impact parameter cross - sections agree with Born's values at the highest available energy, are always higher than Born's results at lower energies, confirming that the method is unreliable for these transitions.

Equation (3.18) was used in Paper C to calculate cross - sections for some transitions in helium. The results for the  $2^1P \rightarrow 3^1D$  and  $4^1D$  transitions are given in table (2. ), and are in good agreement with cross-sections obtained in the first - order impact parameter method without cut - off. The application of the method of paper C to transitions in hydrogen is discussed in Chapter IV.



## CHAPTER IV

### Electron excitation of $n \rightarrow n'$ transitions in hydrogen

#### § 4.1 Introduction

Collisional excitation of hydrogen by electron impact is of great importance in many physical problems occurring, for example, in plasma physics and astrophysics. In a number of cases, theoretical studies require cross - sections  $Q_{nn'}$  for  $n \rightarrow n'$  transitions in hydrogen, where  $n$  and  $n'$  respectively are the initial and final principal quantum numbers of the atom. For example, consider a recombining plasma consisting only of hydrogen atoms, protons, and free electrons which have a Maxwellian energy distribution of temperature  $T_e$ . Let  $N(c)$  be the number density of free electrons, and let  $N(n), N(n'), \dots$  be the number densities of hydrogen atoms in levels with principal quantum numbers  $n, n', \dots$ .

Bates, Kingston and McWhirter (1962) show that these number densities are governed by an infinite set of linear equations which may be written as

$$\begin{aligned} N(n) \{ N(c) [ K(n, c) + \sum_{n' \neq n} K(n, n') ] + \sum_{n' < n} A(n, n') \} \\ = N(c) \sum_{n' \neq n} N(n') K(n', n) + \sum_{n' > n} N(n') A(n', n) \\ + N(c)^2 \{ N(c) K(c, n) + \beta(n) \} \end{aligned}$$

(4.1)

for all  $p > 1$ . Here  $\beta(n)$  is the rate coefficient for radiative recombination,  $A(n, n')$  is the Einstein spontaneous emission coefficient and  $K(c, n)$ ,  $K(n, c)$  and  $K(n, n')$  are the electronic rate coefficients for ionization, three-body recombination and excitation or de-excitation, respectively. The  $K$ 's depend on the cross-sections  $Q_{nn'}$ , being given by

$$K(n, n') = \frac{8\pi}{m_e^{1/2}} \frac{1}{(2\pi k T_e)^{3/2}} \int_{E_n - E_{n'}}^{\infty} Q_{nn'} e^{-E/kT_e} E dE \quad (4.2)$$

where  $m_e$  is the electron mass and  $k$  is Boltzmann's constant. The electron recombination coefficient  $\alpha$  is also dependent on the  $Q_{nn'}$ , since it is given by

$$\begin{aligned} \alpha N^2(c) &= -\frac{dN(c)}{dt} = \dot{N}(1) \\ &= N(c) \sum_{n' \neq 1} N(n') K(n', 1) + \sum_{n' > 1} N(n') A(n', 1) \\ &\quad + N(c)^2 \{ N(c) K(c, 1) + \beta(1) \} \end{aligned} \quad (4.3)$$

The infinite set of equations can be reduced to a finite set, and the recombination coefficients obtained from (4.1) and (4.3) will be exact for a wide range of  $T_e$  and  $N(c)$  if the  $A$ 's,  $\beta$ 's and  $K$ 's are exact (c.f. Bates et. al., 1962). The  $A$ 's and  $\beta$ 's are known to a high degree of accuracy and so, in order to calculate the recombination coefficients, we need to be able to calculate large numbers of  $Q_{nn'}$  to a fair degree of accuracy.

In the past the values of the  $\sigma_{nn'}$  used have been based on the classical formulae of Gryzinski (1959, 1966), but these have the wrong high - energy behaviour. Because of the large number of transitions involved (approximately  $nn'$  for large  $n$ ), detailed quantal calculations on all of them are extremely lengthy, even in Born's approximation. We use the semi-empirical formulae developed by Stauffer and McDowell (1966), henceforth referred to as Paper I (see Chapter III), which give a comparatively quick method of estimating semi-classical total cross-sections (with the correct high - energy behaviour) for sets of  $n \rightarrow n'$  transitions, to within a factor of two. The results are compared with Born and classical estimates.

#### § 4.2 The Classical Impulse Approximation

In the classical impulse approximation, the following assumptions are made :

1. The projectile is treated as a classical particle following a classical trajectory with impact parameter  $b$ , and initial energy  $E$ .
2. The binding forces in the target do not affect the interaction between the target and the projectile.
3. The target electrons do not interact with each other during the collision, and their interactions with the projectile may be treated independently, the resulting cross-sections being summed to give the total cross-section.
4. The interactions of the projectile with the target are Coulombic.

mass  $m_1$ , and an incident electron

Consider the interaction between a bound electron mass  $m_2$ . Let  $\underline{v}_1$  and  $\underline{v}_2$  respectively be their initial velocities in the laboratory frame,  $\Theta$  be the angle between  $\underline{v}_1$  and  $\underline{v}_2$  and  $\Phi$  be the angle the plane of  $\underline{v}_1$  and  $\underline{v} = \underline{v}_2 - \underline{v}_1$  makes with the plane of  $\underline{v}_1$  and  $\underline{v}_2$ . Let primes indicate the same quantities after the collision. From the laws of conservation of energy and angular momentum :

$$m_1 \underline{v}_1 + m_2 \underline{v}_2 = m_1 \underline{v}_1' + m_2 \underline{v}_2' \quad (4.4)$$

$$\frac{1}{2} m_1 v_1^2 + \frac{1}{2} m_2 v_2^2 = \frac{1}{2} m_1 v_1'^2 + \frac{1}{2} m_2 v_2'^2 \quad (4.5)$$

Let  $\underline{V}_g$  be the (constant) velocity of the centre of mass. Then

$$m_1 \underline{v}_1 + m_2 \underline{v}_2 = M \underline{V}_g \quad (4.6)$$

where  $M = m_1 + m_2$ .

Putting  $M_i = \frac{m_i}{M} \quad (i = 1, 2)$ ,

we obtain

$$\underline{v}_1 = \underline{V}_g - M_2 \underline{V} \quad ; \quad \underline{v}_2 = \underline{V}_g + M_2 \underline{V} \quad (4.7)$$

so that, if  $\Phi$  is the angle between  $\underline{V}$  and  $\underline{V}_g$ ,

$$v_1'^2 = V_g^2 - 2 M_2 V_g V \cos \Phi + M_2^2 V^2 \quad (4.8)$$

and  $\Delta E = \mu V_g V (\cos \Phi' - \cos \Phi) \quad (4.9)$

is the energy transfer, where  $\mu = \frac{m_1 m_2}{M}$

From (4.4) and (4.6)

$$V_g^2 = M_1 v_1^2 + M_2 v_2^2 + 2 M_1 M_2 v_1 v_2 \cos \Theta \quad (4.10)$$

Using this in (4.8) gives

$$\cos \Phi = \frac{\{m_2 v_2^2 - m_1 v_1^2 + (m_1 - m_2) v_1 v_2 \cos \Theta\}}{M V_g V} \quad (4.11)$$

The classical deflection,  $\Theta$ , is given by

$$\Theta = \pi - 2 \Psi_g \quad (4.12)$$

where

$$\Psi_g = \int_{r_{min}}^{\infty} \frac{dr}{r} \left[ \left( \frac{r}{\rho} \right)^2 \left\{ 1 - \frac{V(r)}{E} \right\} - 1 \right]^{-\frac{1}{2}} \quad (4.13)$$

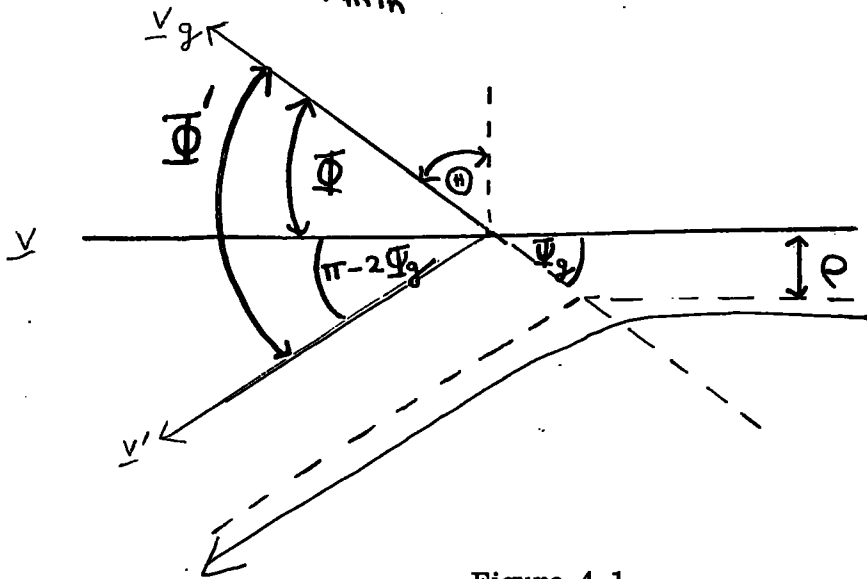

Figure 4.1

For interactions of the form  $V(r) = \frac{k}{r^{1-\nu}}$  it is convenient to change

the variables to

$$y = \frac{e}{r}, \quad y_0 = e \left( \frac{2E}{k} \right)^{\frac{1}{\nu-1}}$$

so that, in particular, for coulomb potentials ( $\nu = 2$ ),

$$\begin{aligned}\Psi_g &= \int_{r_{\min}}^{\infty} \frac{dr}{r} \left[ \frac{1}{y^2} \left\{ 1 - \frac{2y}{y_0} \right\} - 1 \right]^{-\frac{1}{2}} \\ &= \int_0^{y_{\min}} \left\{ 1 - \frac{2y}{y_0} - y^2 \right\}^{-\frac{1}{2}} dy\end{aligned}$$

where  $y_{\min} = y_0^{-1} + (1 + y_0^{-1})^{\frac{1}{2}}$

On integrating, we obtain

$$\begin{aligned}\cos \Psi_g &= \frac{1}{\sqrt{1 + y_0^2}} \\ &= \left( 1 + \left( \frac{2E_p}{k} \right)^2 \right)^{-\frac{1}{2}} \\ &= \left[ 1 + \left( \frac{\mu_e v^2}{k} \right)^2 \right]^{-\frac{1}{2}}\end{aligned}$$

(4.12)

From figure 4.1,

$$\begin{aligned}\cos \Phi' &= \cos \Phi \cos (\pi - 2\Psi_g) \\ &\quad + \sin \Phi \sin (\pi - 2\Psi_g) \cos (\Theta)\end{aligned}$$

(4.14)

Using (4.11) and (4.14) in (4.9)

$$\Delta E = -2\mu V_g V \cos^2 \Psi_g (\cos \Phi - \sin \Phi \cos \Phi \tan \Psi_g) \quad (4.15)$$

Putting  $x = \frac{\mu_p v^2}{k}$

gives, from (4.12')

$$\cos \Psi_g = \frac{1}{(1+x^2)^{\frac{1}{2}}}, \quad \sin \Psi_g = \frac{x}{(1+x^2)^{\frac{1}{2}}} \quad (4.16)$$

Hence

$$\Delta E = \frac{-2\mu V_g V}{(1+x^2)V_g V} \left[ M_2 v_2^2 - M_1 v_1^2 + \left( \frac{m_1 - m_2}{M} \right) v_1 v_2 \cos \Theta - v_1 v_2 \sin \Theta \cos \Theta x \right]$$

or

$$\Delta E = \frac{-K_{12}}{1+x^2} \left[ E_2 - E_1 + \frac{1}{2} v_1 v_2 \left\{ (m_1 - m_2) \cos \Theta - (m_1 + m_2) x \sin \Theta \cos \Theta \right\} \right]$$

(4.17)

where

$$K_{12} = \frac{4 m_1 m_2}{(m_1 + m_2)^2} \quad (4.18)$$

The differential cross-section for a collision in which the incident particle loses energy  $E$  is then obtained on integrating over  $\Theta$  (Stabler, 1964).

Since the differential cross-section must be real and positive, we have from (4.17)

$$\frac{d\sigma(v_1, v_2)}{d(\Delta E)} = \pi \left( \frac{\hbar}{\mu} \right)^2 \frac{1}{v^4 |\Delta E|^2} \left( \frac{2a^2}{\Delta E} - b \right) \quad (4.18)$$

where

$$a = \mu v_1 v_2 \sin \Theta, \\ b = K_{12} \left[ E_2 - E_1 + \frac{1}{2} (m_1 - m_2) v_1 v_2 \cos \Theta \right] \quad (4.19)$$

This is real provided  $-\pi \leq \Theta \leq \pi$ , which, by (4.17) occurs if

$$W = 4a^2 \sin^2 \Psi_g \cos^2 \Psi_g - (\Delta E + b^2 \cos^2 \Psi_g)^2 \geq 0 \quad (4.20)$$

We can re-write this condition as

$$4a^2 x^2 - \{(1+x^2)\Delta E + b^2\}^2 \geq 0$$

which is true if,

$$-\Delta E^2 - b\Delta E + a^2 \geq 0 \quad (4.21)$$

We now assume that the distribution of  $\underline{v}$  is isotropic, and obtain the differential cross - section in the form

$$V \frac{d\sigma(v_1, v_2)}{d\Delta E} = \frac{1}{2} \int_{\cos\Theta_1}^{\cos\Theta_2} V \frac{d\sigma(v_1, v_2)}{d\Delta E} d\cos\Theta \quad (4.22)$$

where the bounds on  $\cos\Theta$  are obtained from (4.21) The ionization cross-section for particles of energy  $E_2$  incident on particles of energy  $E_1$ , bound by  $U$  is then

$$\Phi_{ion}(E_2, E_1, U) = \frac{1}{v_2} \int_{-U}^{-E_2} V \frac{d\sigma(v_1, v_2)}{d\Delta E} d\Delta E \quad (4.23)$$

Upon integration, this becomes

$$\Phi_{ion}(E_2, E_1, U) = \frac{2(E_2 - U)^{3/2}}{3E_2 U^2 E_1^{1/2}}, \quad U \leq E_2 < E_1 + U \quad (4.24)$$



$$= \frac{1}{3E_2} \left[ \frac{2E_1 + 3U}{U^2} - \frac{3}{E_2 - E_1} \right], \quad E_2 > E_1 + U \quad (4.24')$$

Excitation to a discrete state is in a sense alien to classical theories, which give directly only the cross - section for a collision in which an energy between  $E$  and  $E + dE$  is transferred to the target electron. The choice of which classical energy band is taken to represent the final quantum state is, to some extent, arbitrary. It is customary to assign to the final quantum state the energy band lying between it and the level with the next highest quantum number, so that, for excitation from initial state  $n$  to final state  $n'$ ,

$$\Delta E_{n,n'} \leq -\Delta E \leq \Delta E_{n,n'+1} \quad (4.25)$$

where  $\Delta E_{n,n'} = \frac{1}{2} \left( \frac{1}{n^2} - \frac{1}{n'^2} \right)$

Using this, and (4.24') gives Stabler's expressions for the excitation cross - section at impact energy  $W_i$ :

$$Q_{nn'}^s(W_i) = \frac{2(W_i - \Delta E_{nn'})^{3/2}}{3W_i E_n^{1/2} \Delta E_{nn'}^2}, \quad \Delta E_{nn'} \leq W_i \leq \Delta E_{n,n'+1} \quad (4.26)$$

$$= \frac{2}{3W_i E_n^{1/2}} \left[ \frac{(W_i - \Delta E_{nn'})^{3/2}}{\Delta^2 E_{nn'}} - \frac{(W_i - \Delta E_{n,n'+1})^{3/2}}{\Delta^2 E_{n,n'+1}} \right],$$

$$\Delta E_{n,n'+1} \leq W_i \leq E_n + \Delta E_{n,n'} \quad (4.27)$$

$$= \frac{2}{3W_i} \left[ \frac{2E_n + 3\Delta E_{nn'}}{2\Delta E_{nn'}^2} - \frac{3}{2(W_i - E_n)} - \frac{(W_i - \Delta E_{n,n'+1})^{3/2}}{E_n^{1/2} \Delta E_{n,n'+1}^2} \right],$$

$$E_n + \Delta E_{nn'} \leq W_i \leq E_n + \Delta E_{n,n'+1} \quad (4.28)$$

$$= \frac{2}{3W_i} \left[ \frac{1}{\Delta E_{nn'}} - \frac{1}{\Delta E_{n,n'+1}} \right] \left[ E_n \left( \frac{1}{\Delta E_{nn'}} + \frac{1}{\Delta E_{n,n'+1}} \right) + \frac{3}{2} \right],$$

$$W_i > E_n + \Delta E_{n,n'+1} \quad (4.29)$$

Since  $\Delta E_{nn'} - \Delta E_{n,n'+1}$  is small, almost the whole incident energy spectrum is spanned by (4.27) and (4.29).

Gryzinski (1959, 1965) expresses (4.24) as

$$Q(E_1, E_2, U) = \frac{1}{UE_1} \int_{\theta_1}^{\theta_2} f(V) \left[ \alpha \left\{ \frac{\alpha E_1 \sin^2 \theta}{U} + 1 - \frac{E_1}{E_2} - \frac{v_1}{v_2} \left( 1 - \frac{m_1}{m_2} \right) \cos \theta \right\} \right]_{\alpha=1}^{\alpha=U/|\Delta E|} f(\theta) d\theta \quad (4.30)$$

by integrating over  $d(\Delta E)$ ,

$$\text{where } f(V) = \left( \frac{v_1}{v_2} \right)^2 \left( \frac{v_2^2}{v_1^2 + v_2^2 - 2v_1 v_2 \cos \theta} \right)^{3/2} \quad (4.31)$$

and  $f(\theta)$  is the angular distribution of the relative velocity, normally taken

to be isotropic. Gryzinski (1959) replaces  $f(V)$  by

$$f_0(V) = \frac{v_2 v_1}{(v_1^2 + v_2^2)^{3/2}}, \quad (4.32)$$

and, using (4.25), obtains the excitation cross-section

$$Q^G(W_i) = Q(\Delta E_{nn'}) - Q(\Delta E_{n,n'+1}) \quad (4.33)$$

where

$$Q_G(U) = \frac{1}{U^2} \left( \frac{W_i}{W_i+U} \right)^{3/2} \times \begin{cases} \frac{2}{3} \frac{E_n}{W_i} \left( 1 - \frac{E_n}{W_i} \right) - \left( \frac{U}{W_i} \right)^2 & \text{if } U + E_n \leq W_i \\ \frac{2}{3} \left[ \frac{E_n}{W_i} + \frac{U}{W_i} \left( 1 - \frac{E_n}{W_i} \right) - \left( \frac{U}{W_i} \right)^2 \right] \\ \times \left[ \left( 1 + \frac{U}{E_n} \right) \left( 1 - \frac{U}{W_i} \right) \right]^{\frac{1}{2}} & \text{if } U + E_n > W_i \end{cases} \quad (4.33)$$

(in units of  $\pi a_0^2$ )

$$\text{For large } n', \quad \Delta E_{nn'} - \Delta E_{n,n'+1} \approx \frac{1}{n'^3} \quad (4.34)$$

and so, by Taylor's theorem

$$Q^G(W_i) = \frac{1}{n'^3} \left[ \frac{d}{dU} Q^G(U) \right]_{U=\Delta E_{nn'}} + O\left(\frac{1}{n'^6}\right) + \dots \quad (4.35)$$

Taking the first term only in this expansion gives Kingston's (1964)

approximation to Gryzinski's formulae :

$$Q_{nn'}^{IK}(W_i) = \frac{1}{n'^3 W_i \Delta E_{nn'}^2} \left( \frac{W_i}{W_i + E_n} \right)^{3/2} \times \begin{cases} \frac{7E_n - 3E_n'}{3\Delta E_{nn'}} - \frac{E_n}{W_i} & \text{if } 2E_n - E_n' \leq W_i \\ \frac{1}{3} \left( \frac{2E_n - E_n'}{E_n} \right)^{\frac{1}{2}} \left[ \frac{(5E_n - E_n')}{\Delta E_{nn'}} + \frac{(E_n - 2E_n')}{W_i} \right] \left( 1 - \frac{\Delta E_{nn'}}{W_i} \right)^{\frac{1}{2}} & \text{if } 2E_n - E_n' > W_i \end{cases} \quad (4.36)$$

A asymptotically

$$Q_{nn'}^k \underset{W_i \rightarrow \infty}{\sim} \frac{(7E_n - 3E_{n'})}{3W_i(n'\Delta E_{nn'})^3} \quad (4.37)$$

whereas, from (4.29)

$$Q_{nn'}^s \underset{W_i \rightarrow \infty}{\sim} \frac{1}{3W_i(n'\Delta E_{nn'})^3} \left[ (7E_n - 3E_{n'}) - \frac{3}{2n'^3} \left( \frac{2E_n}{\Delta E_{nn'}} + 1 \right) \right] \quad (4.38)$$

so that  $Q_{nn'}^k$  and  $Q_{nn'}^s$  will agree at high energies only if  $n'$  is large, and  $n$  is small compared with  $n'$ .

Gryzinski's (1959) cross - sections, given by (4.33) are in good agreement with experiment at moderate energies for a variety of inelastic processes. Stabler, however, points out that Gryzinski's work is a modification of the "exact" classical impulse approximation, because the subsidiary approximation of averaging over the initial angular distribution of the atomic electrons has been made. Although in general this approximation improves the agreement with experiment (due to the decreased weighting given to collisions with long interaction times), it complicates the form of the cross-sections, and makes the equations behave improperly under time - reversal.

A major defect in classical theories is that the cross - sections behave as  $W_i^{-1}$  instead of  $W_i^{-1} \log W_i$  for large  $W_i$ . In a second attack on the problem. Gryzinski (1965) averages  $Q_G$  over a velocity distribution.

$$f_G(v_i) = \frac{1}{(n-2)!} \left( \frac{v_{10}}{v_i} \right)^n e^{-\frac{v_{10}}{v_i}} \quad (4.39)$$

where  $v_{10}$  is adjusted to normalize his distribution. When  $n = 3$ , a log term appears in  $Q_G$ , so his expression then has the correct high - energy behaviour. The velocity distribution in an atom is, however, never of the form (4.39), being given by

$$f(t^2) dt^2 = \frac{16}{\pi} t \frac{dt^2}{(t^2+1)^4} \quad (4.40)$$

where

$$t^2 = \frac{v^2}{v_0^2}$$

(Mapleton 1966). Gryzinski's (1965) final expression for  $Q_G$  is therefore essentially empirical, and is unjustified from a theoretical point of view.

### § 4.3 Application of the impact parameter method with cut - off

Using the first order impact parameter method with a cut - off  $R_0$ , Stauffer and McDowell (1966) obtain equation (3.18) for the cross - section for excitation of an atom from initial state  $a$  to final state  $b$ . When the atom concerned is hydrogen-like this equation becomes much simpler, since the reduced matrix element may be written

$$\begin{aligned}
 & | \langle \Gamma_2 \ell_2 | | \psi_{\lambda} | | \Gamma_1 \ell_1 \rangle |^2 \\
 &= \left( \begin{array}{ccc} \ell_1 & \ell_2 & \lambda \\ 0 & 0 & 0 \end{array} \right)^{-2} | \langle \Gamma_2 \ell_2 m_{\ell_2=0} | \psi_{\lambda 0} | \Gamma_1 \ell_1 m_{\ell_1=0} \rangle |^2
 \end{aligned}
 \tag{4.41}$$

(Edmonds 1957), where  $|\Gamma, \ell, m_{\ell}\rangle$  is the  $(n, \ell, m_{\ell})$  hydrogen atom wave function and

$$\psi_{\lambda 0} = r^{\lambda} Y_{\lambda 0}(\theta, \phi),
 \tag{4.42}$$

$r, \theta, \phi$  being the spherical polar co-ordinate of the atomic electron in a suitable reference frame.

Noting that

$$\begin{aligned}
 & \int Y_{\ell m}^*(\theta, \phi) Y_{\lambda 0}(\theta, \phi) Y_{\ell' m'}(\theta, \phi) d\Omega \\
 &= (-1)^{m'} \sqrt{\frac{(2\ell+1)(2\lambda+1)(2\ell'+1)}{4\pi}} \begin{pmatrix} \ell & \lambda & \ell' \\ 0 & 0 & 0 \end{pmatrix} \begin{pmatrix} \ell & \lambda & \ell' \\ -m & 0 & m' \end{pmatrix}
 \end{aligned}
 \tag{4.43}$$

we obtain

$$\begin{aligned}
 \Phi_{m\ell, n'\ell'}(W_i) &= 4(2\ell'+1) \times \\
 & \sum_{\lambda, \mu} \frac{\Delta E_{nn'}^{\lambda-2} |g_{\lambda\ell\ell'}|^2 \chi_{\mu}(\beta_0)}{(2\lambda+1)^2 2^{2\lambda-2} m(m-\frac{1}{2})^{\lambda-1} (\lambda-\mu)! (\lambda+\mu)!} \begin{pmatrix} \ell & \ell' & \lambda \\ 0 & 0 & 0 \end{pmatrix}^2
 \end{aligned}
 \tag{4.44}$$

where

$$g_{\lambda\ell\ell'} = \int_0^{\infty} r^{\lambda+2} R_{n\ell}^*(r) R_{n'\ell'}(r) dr,
 \tag{4.45}$$

$$m = \frac{W_i}{\Delta E_{nn'}} \quad (4.46)$$

and  $\chi_\mu(\beta_0)$  is given by equation (3.19),  $\beta_0$  being the  $\beta$  of equation (3.17) with  $R$  replaced by the cut-off  $R_0$ .

Following Stauffer and McDowell (3.21) (1965) we chose

$$R_0 = \tau_0 = \frac{(2\ell_+ + 1)\bar{r}_- + (2\ell_- + 1)\bar{r}_+}{(2\ell_+ + 1) + (2\ell_- + 1)} \quad (4.47)$$

where  $\ell_-$  is the lesser and  $\ell_+$  the greater of the orbital angular momenta  $\ell$  and  $\ell'$ , with a similar definition for  $\bar{r}_-$  and  $\bar{r}_+$  in terms of the initial and final average radial distances of the atomic electron from the nucleus. We examined the sensitivity of  $Q(W_i)$  to changes of up to 50% in the above choice of  $R_0$  for the transitions  $1s$  or  $2s \rightarrow 3p$  or  $3d$ , evaluating the cross-sections at  $m = 1, 5, 10, 50$  and  $100$ . The results for  $1s \rightarrow 3p$  and  $1s \rightarrow 3d$  are shown in figure 4.1. Below  $m = 5$ , the cross-sections are extremely sensitive to choice of  $R_0$ . Changing  $R_0$  by a factor of two alters  $Q$  by more than an order of magnitude for the forbidden transitions, and by as much as two orders of magnitude for the allowed transitions. Above  $m = 5$ , the forbidden transitions are the more sensitive but in no case does  $Q$  change by more than a factor of four. Errors of 25% in  $R_0$  give  $Q$  correct to within a factor of two. We would, however, expect larger errors when the lowest contributing multipole is  $\ell_+, 3$ .

For comparison with  $\Phi_{nn'}^S$  and  $\Phi_{nn'}^K$  we must calculate the total cross - section  $\Phi_{nn'}$ , defined by

$$\Phi_{nn'}(W_i) = \frac{1}{n^2} \sum_{\ell'=0}^{n'-1} \sum_{\ell=0}^{n-1} (2\ell+1) \Phi_{n\ell, n\ell'}(W_i) \quad (4.48)$$

Equation (3. ), however, was derived using the approximation that the radial distance of the incoming electron is always greater than that of the atomic electron. This means that (4.44) is a poor approximation if  $\ell = \ell'$ . We therefore define

$$\bar{\Phi}_{nn'}(W_i) = \frac{1}{n^2} \sum_{\ell'=0}^{n'-1} \sum_{\ell=0}^{n-1} (2\ell+1) \Phi_{n\ell, n\ell'}(W_i) \quad (4.49)$$

where the prime indicates  $\ell \neq \ell'$ , and suppose there exists a function  $f(W_i)$ , independent of  $n$  and  $n'$ , such that

$$\Phi_{nn'}(W_i) = [1 + f(W_i)] \bar{\Phi}_{nn'}(W_i) \quad (4.50)$$

We can check this by using Omidvar's (1965) Born cross - sections for (2, 3) and (3, 4) to calculate  $\Phi_{23}$ ,  $\bar{\Phi}_{23}$ ,  $\Phi_{34}$  and  $\bar{\Phi}_{34}$ .

$f(W_i)$  for the two sets of transitions is shown in figure 4.2, and we take the average of these curves to give the adopted values of  $f(W_i)$  shown in table 4.1.

Somerville's (1963) Born results for the (1, 3) and (1, 2) transitions give values of



$f(w_i)$  somewhat lower than these, but we expect our adopted values to be accurate to within 10% for transitions not involving the ground state ( $n = 1$ ) where the contribution from forbidden transitions is anomalously low.

TABLE 4.1

Correction Function  $f(m)$  calculated from Born cross sections

m	2	10	60	100	1000
$f(m)$	0.24	0.13	0.075	0.067	0.046

#### § 4.4 Results and discussion

The individual cross - sections  $Q_{n\ell, n'\ell'}(w_i)$  and the total cross - section  $Q_{nn'}(w_i)$  were calculated from (4.4), (4.8) and (4.10) for a number of  $(n, n')$ , with  $R_0 = r_a$ . Contributions from the allowed transitions dominate the sum  $Q_{nn'}$  at high energies. These contributions have the correct high - energy behaviour (see Paper I), and are related to the oscillator strength  $f_{ji}$  for the particular  $i \rightarrow j$  transition by equations (3. ) and (3. ). They are individually in close agreement with the Born results except when the ratio  $\frac{f_{ji}}{\Delta E_{nn'}}$  is small ; that is, when the coupling between the initial and final states is very weak. (Seaton, 1962). The ratio is large compared with unity for  $\Delta n = n' - n \leq 2$ , the limiting case being  $\Delta n = 2$  when (Allen, 1955) both  $f_{ji}$  and  $\Delta E_{nn'}$  are proportional

to  $n^{-3}$ . For large  $\Delta n$  the ratio is proportional to  $n^{-1}$  and is normally small. We can therefore expect our method to be reliable only for  $\Delta n = 1$  or 2, and this is confirmed by the detailed calculations. For example in the (2, 6) case, ( $\Delta n = 4$ ),  $Q_{nn'}(W_i)$  lies more than an order of magnitude below the total Born cross-section  $Q_{nn'}^B$  (Omidvar 1965) at the peak, and only joins on to a reasonable extrapolation of the Born curve at energies above 1000 e.v.

In figures 4.3, (a), (b) and (c) we compare  $Q_{3l,4l'}(W_i)$  for all the nine  $\Delta l \neq 0$  transitions with the Born approximation results of McCoyd et. al. (1960), also including their values for the  $\Delta l = 0$  case. Except for  $3d \rightarrow 4s$  (where in any case the contribution to  $Q_{34}$  is negligible),  $Q_{nl,n'l'}$  always lies below the Born value at low energies and approaches it at high energies.

In figures 4.4, 4.5 and 4.6 we give the ratios of  $Q$ ,  $Q^S$  and  $Q^K$  to Omidvar's  $Q^B$  for the (3, 4), (4, 6) and (4, 5) cases respectively. (We found that Omidvar's values for  $Q_{4,5}^B$  were inconsistent, and smoothed them to give a constant value of  $\frac{W_i Q(W_i)}{\log W_i}$ . Omidvar's high-energy results for the (4, 5) and (4, 6) cases are too high by comparison with the results given in the two papers by Kingston and Lauer (1966). Using the latter results has the effect of increasing the ratios at high energies by 10% in the (4, 5) case and by 5% in the (4, 6) case.) When  $\Delta n = 1$ , neither classical approximation is as reliable as ours at energies above 0.5 rydbergs, while below this energy we are in much closer agreement with Stabler's model than with Kingston's,

particularly at the extremely low impact energies of interest in plasma physics.

For  $\Delta n = 2$  transitions, our results are very close to Stabler's in this region, while they lie almost a factor of ten below Kingston's values. Our results do not show the large peak appearing in Stabler's model, but in any case McDowell (1966) shows this is smoothed out when the model is averaged over the correct energy distribution (4.40). We feel therefore that the uncertainty in Kingston's results at low energies may be much higher than his estimate of a factor of two.

Figure Captions for CHAPTER IV

Figure 4.1 Cross-sections for electron impact excitation of H  $1s \rightarrow 3p$ ,  $1s \rightarrow 3d$  for different choices of  $R_0$ . The solid curves refer to H (3p), the dashed curves to H (3d), and in each set the lowest has  $R_0 = 1.5 r_a$ , and successively  $1.25 r_a$ ,  $r_a$ ,  $0.75 r_a$  upwards.

Figure 4.2 Calculated values of the function  $F(w_i)$  for the (2, 3) and (3, 4) sets of transitions

\_\_\_\_\_ 3  $\rightarrow$  4  
 - - - - - 2  $\rightarrow$  3

Figure 4.3 Cross-sections for individual  $l \rightarrow l'$  transitions in the (3, 4) case, calculated by the method of this paper (solid curves) and in the Born approximation (dashed curves), from McCoyd et. al. (1960)

4.3 (a) : (1)  $10 \times Q_{s \rightarrow p}$  (2)  $Q_{s \rightarrow d}$  (3)  $\frac{1}{2} Q_{s \rightarrow s}$  (Born only)  
 (4)  $0.1 \times Q_{s \rightarrow f}$

4.3 (b) : (1)  $10 \times Q_{p \rightarrow d}$       (2)  $5 \times Q_{p \rightarrow p}$  (Born only)

(3)  $\frac{1}{2} Q_{p \rightarrow f}$

(4)  $\frac{1}{2} Q_{p \rightarrow s}$

4.3 (c) (1)  $Q_{d \rightarrow f}$       (2)  $Q_{d \rightarrow d}$  (Born only)      (3)  $Q_{d \rightarrow p}$

(4)  $Q_{d \rightarrow s}$

N.B. Curve (2) of figure 4.3 (c) should be dashed.

Figure 4.4      The ratios of  $Q_{nn'}$ ,  $Q_{nn'}^K$ ,  $Q_{nn'}^S$  to  $Q_{nn'}^B$  for the (3, 4) set of transitions, the three ratios being denoted by dot-dashed solid, and dashed curves respectively.

Figure 4.5      The same ratio for the (4, 6) set of transitions

Figure 4.6      The same ratio for the (4, 5) set of transitions.

FIG. 4.1

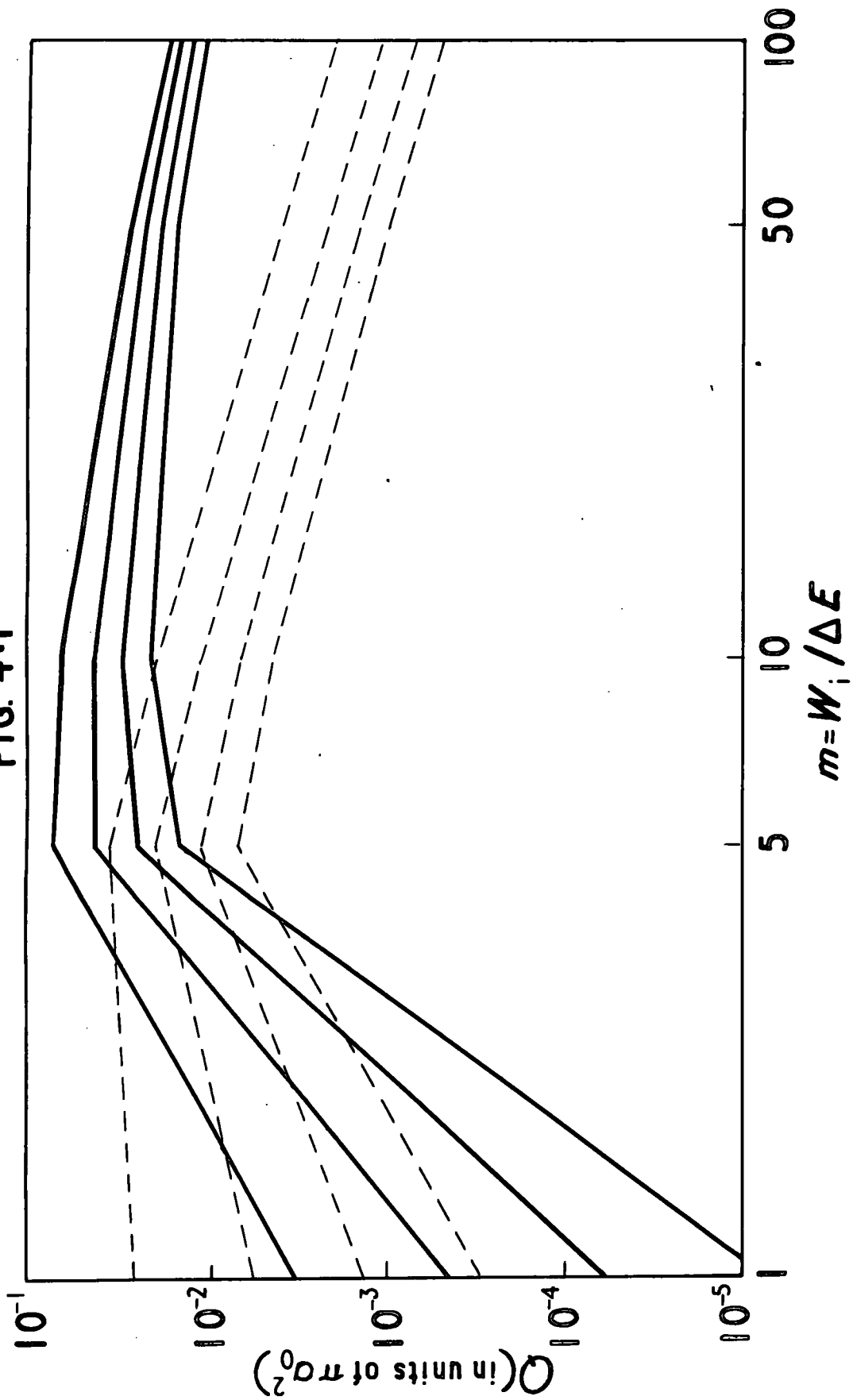

FIG.4-2

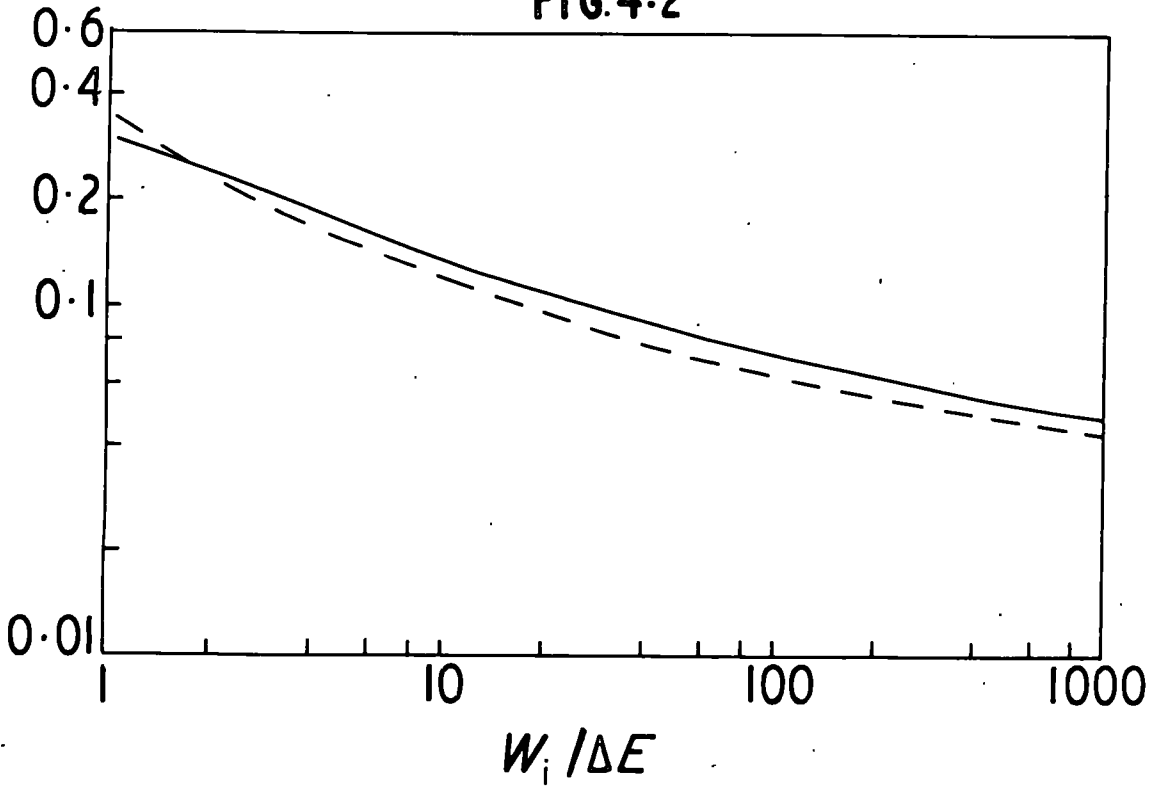

FIG. 4-3 (a)

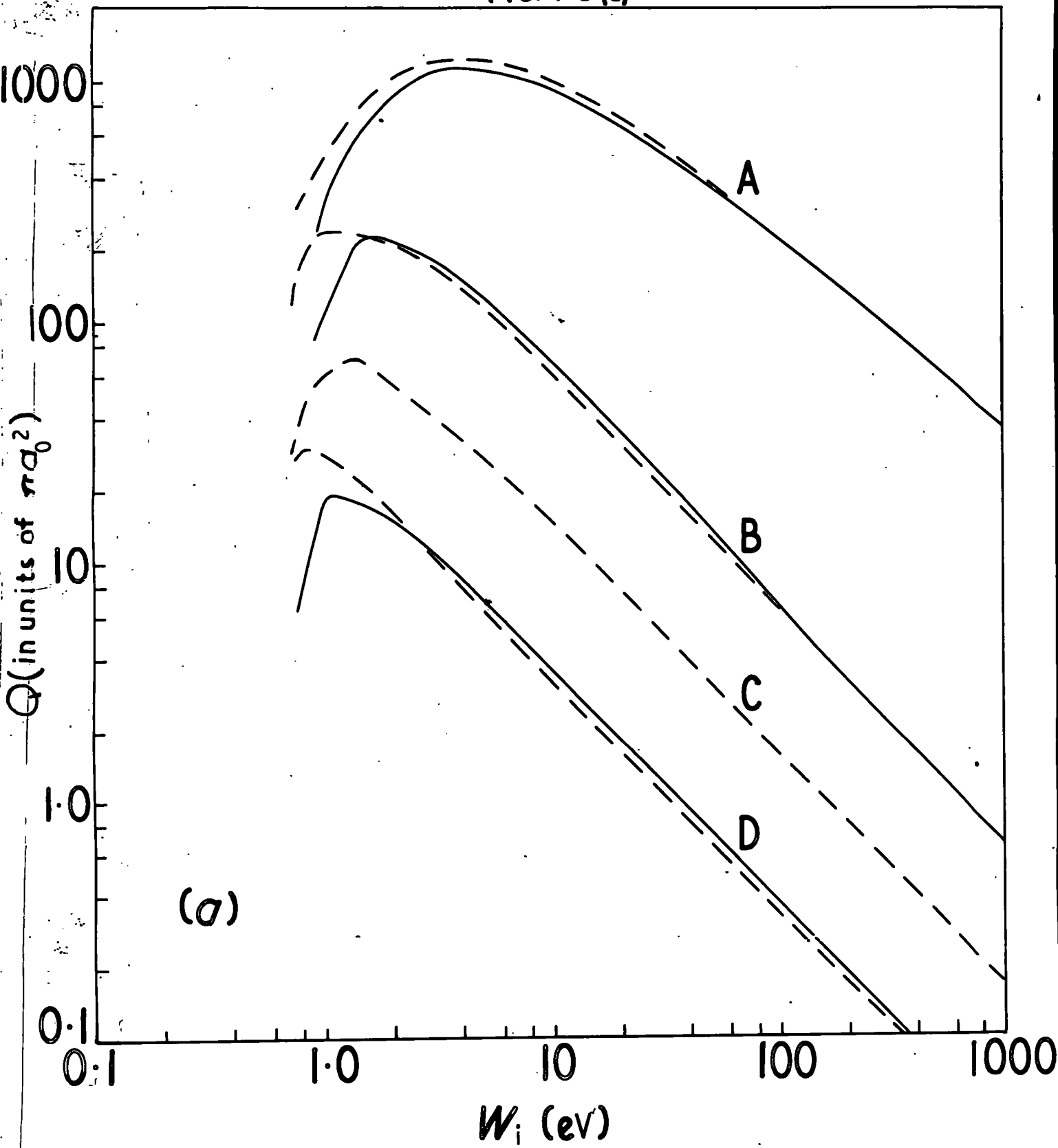

FIG. 4.3(b)

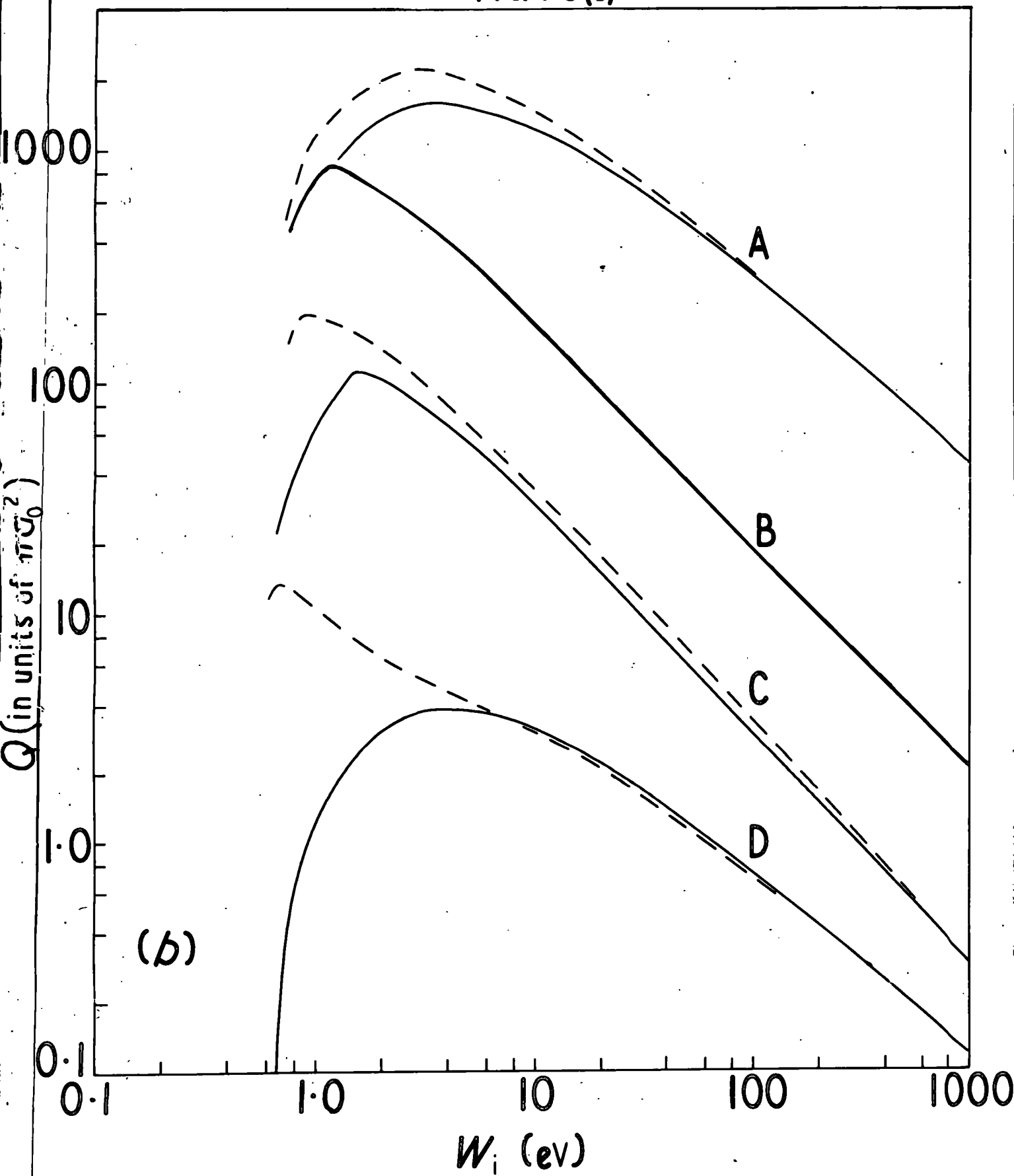
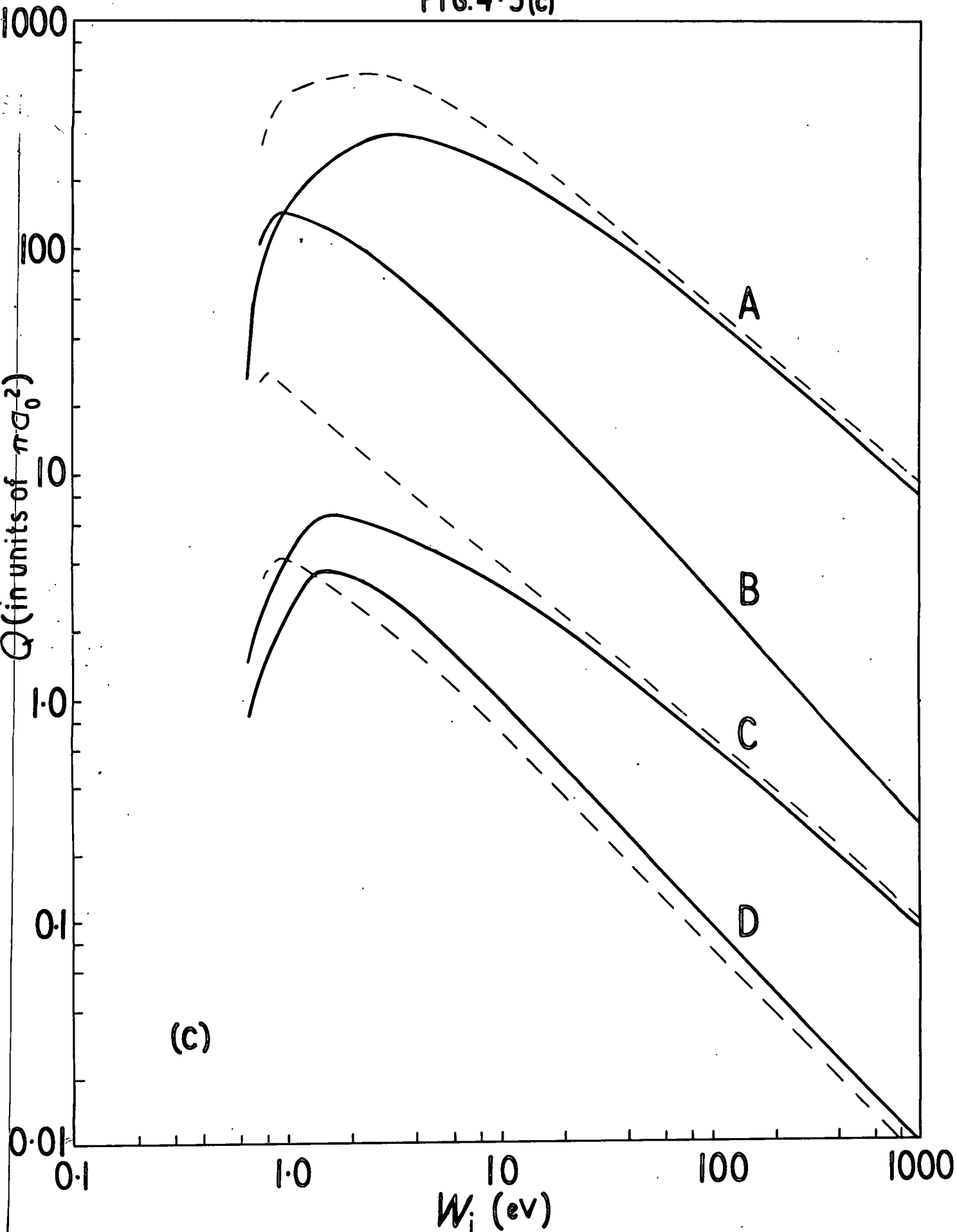



FIG. 4.3(c)



(c)

FIG.4.4

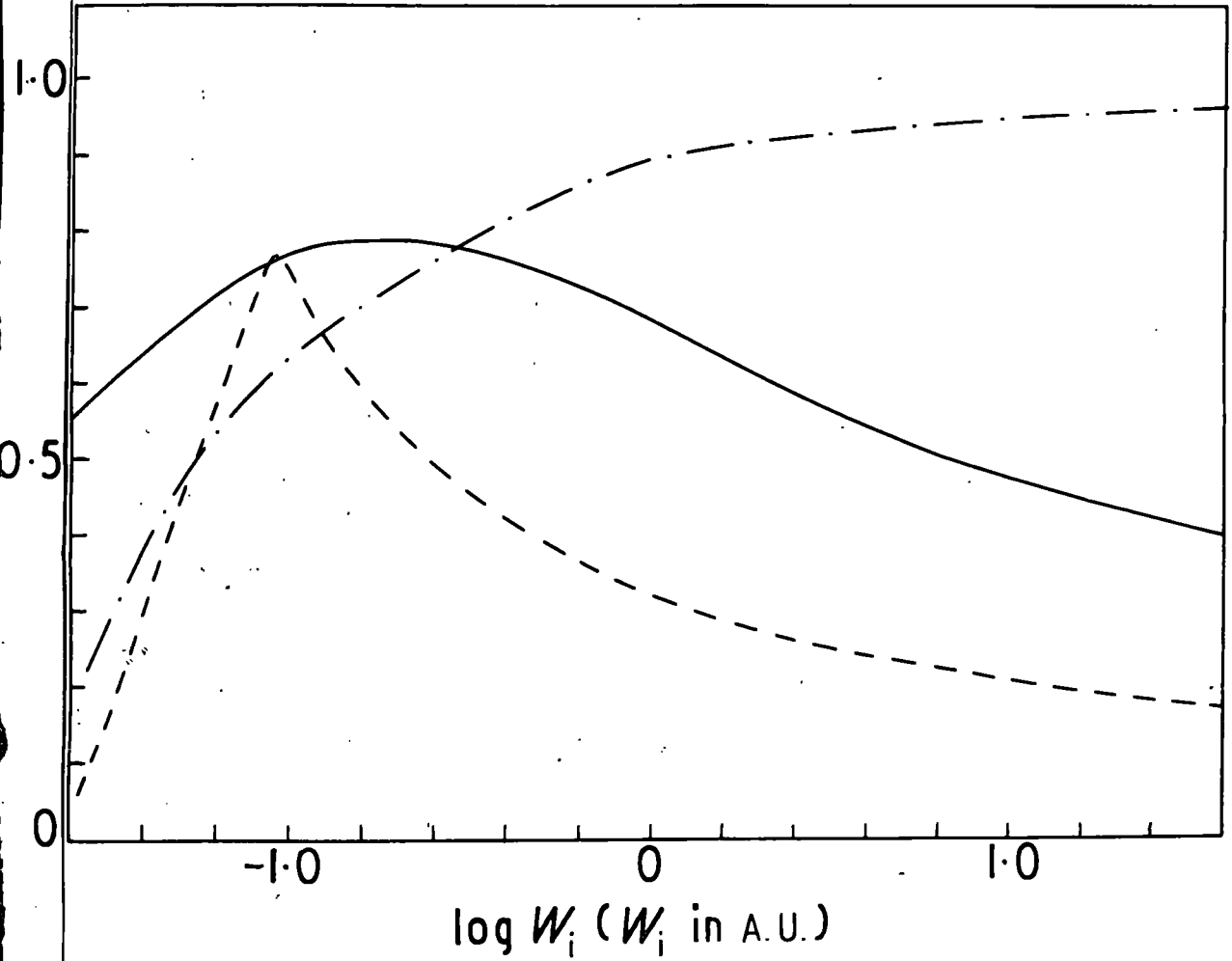

FIG.4.5

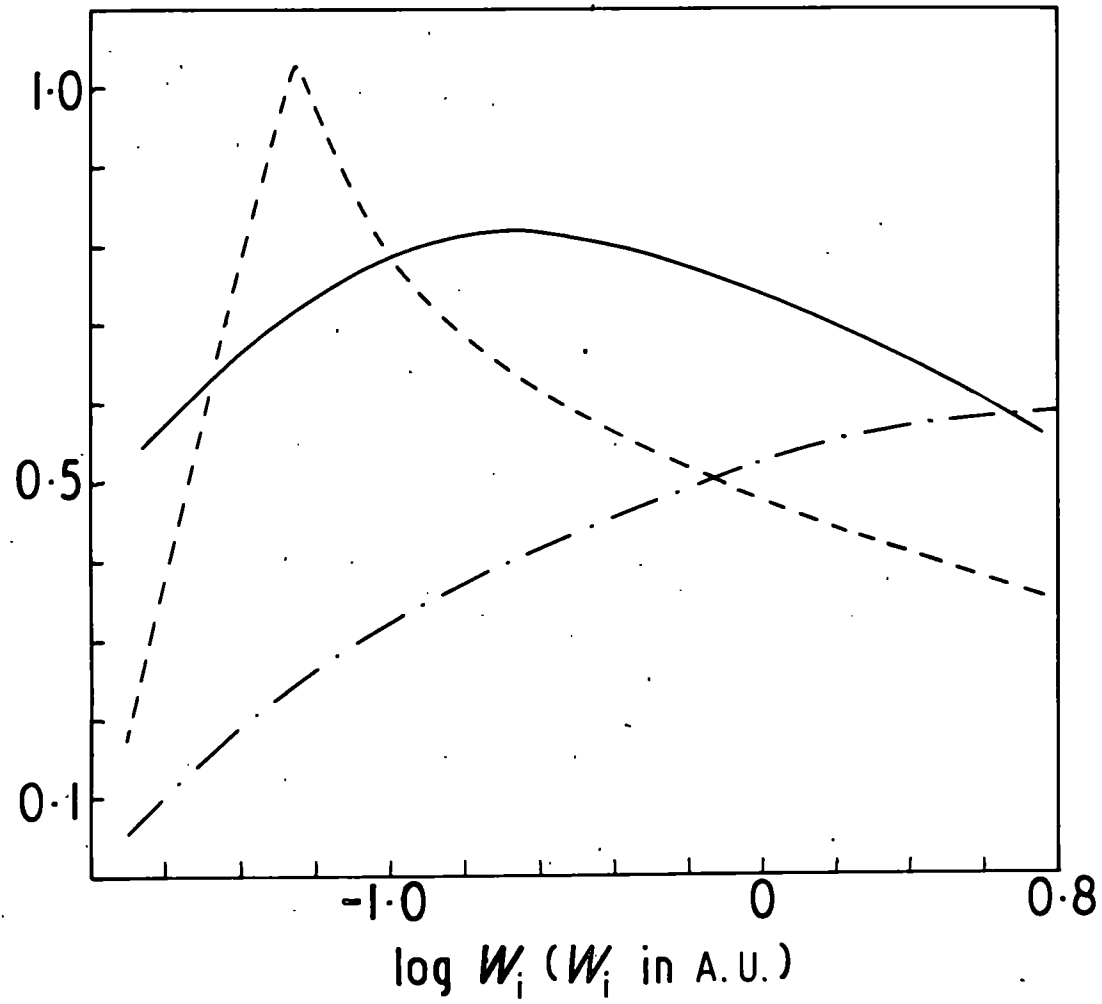
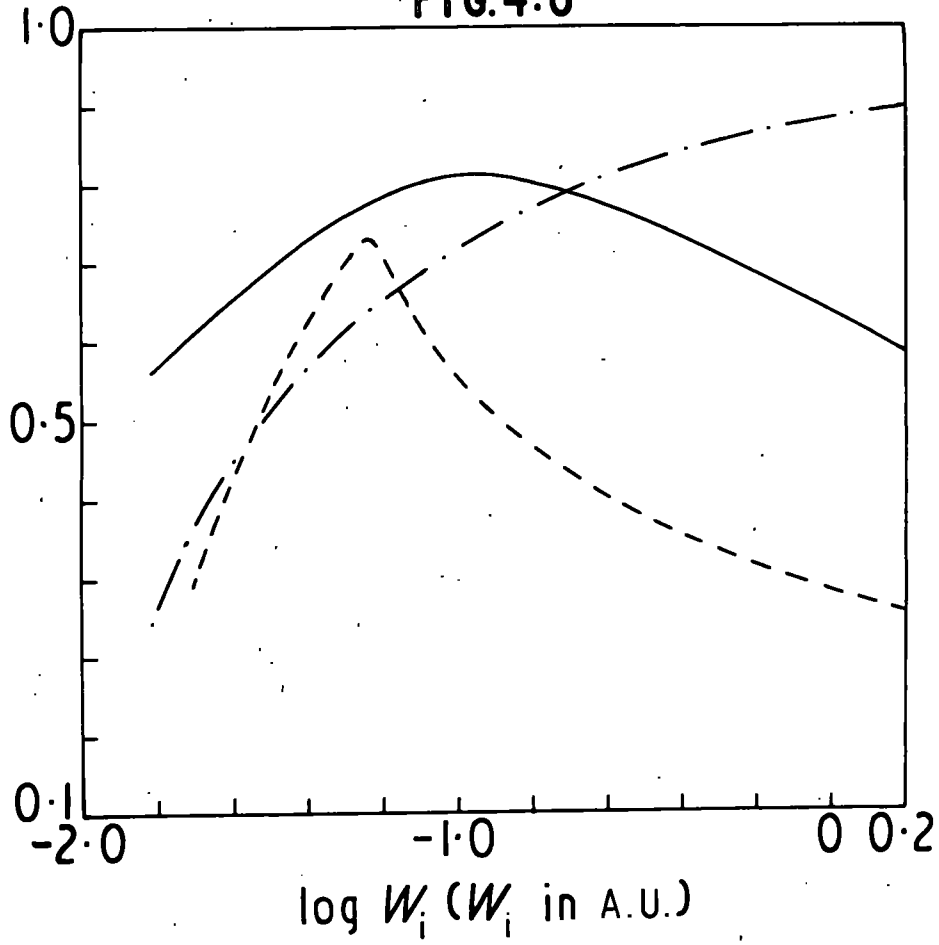

FIG.4.6



## BIBLIOGRAPHY

- Allen, C.W. (1955) "Astrophysical Quantities" (Athlone Press, London)
- Arthurs, A.M. (1961) Proc. Cam. Phil. Soc., 57, 904-5.
- Bates, D.R. (1958) Proc. Roy. Soc. A245, 299
- Bates, D.R. (1961) "Quantum Theory; Vol I. Elements", (Academic Press N. Y. and London, Chapter 8).
- Bates, D.R. and Boyd, A.H. (1962) Proc. Phys. Soc. 79, 710-716.
- Bell R.J. (1961) Proc. Phys. Soc. 78, 903.
- Bell R.J. and Skinner, B.G. (1962) Proc. Phys. Soc. 80, 404.
- Crothers, D.S.F. and Holt, A.R. (1966) Proc. Phys. Soc. 88, 885-8.
- de Heer, F.J. and v. d. Bos, J. (1966) Physica (in press)
- Eckhart C. (1930) Phys. Rev. 36, 878-92.
- Edmonds, A.R. (1957) "Angular Momentum in Quantum Mechanics" (Princeton).
- Fox, M.A. (1966) Proc. Phys. Soc. 88, 65-67.
- Frame, J.W. (1931) Proc. Cam. Phil. Soc. 27, 511-7.
- Gabriel, A.H. and Heddle, D.W.O. (1960) Proc. Roy. Soc. A258, 124-45.
- Gaunt, J.A. (1927) Proc. Cam. Phil. Soc. 23, 732-54.
- Goldstein, H. (1951) "Classical Mechanics" (Addison-Wesley, N. Y.).
- Gryzinski, M. (1959) Phys. Rev. 115, 374-83, (1965) Phys. Rev. 138 A336-A358.
- Heddle, D.W.O. and Lucas, C.B. (1963) Proc. Roy. Soc. A, 271, 129-42
- Kingston, A.E. (1964) Phys. Rev. (135), A1529-A1536.

Kingston, A.E. and Lauer (1966) Proc. Phys. Soc. 87, 399-405.

\_\_\_\_\_ (1966) Proc. Phys. Soc. 88, 597-603.

Mc Carroll, R. and Salin, A. (1966) Comptes Rendues (In press).

Mc Coyd, G.C., Milford, S.N. and Wahl, J.J. (1960) Phys. Rev 119, 149-153.

McDowell, M.R.C. (1966) Proc. Phys. Soc. 89, 23-26.

Mapleton, R. (1966) Proc. Phys. Soc. 87, 219-22.

Molseiwitsch, B.L. (1966) Proc. Phys. Soc. 87, 885-8.

Omidvar, K. (1965) Phys. Rev. 140 A38-A46.

Seaton, M.J. (1962) Proc. Phys. Soc. 79, 1105-1117.

Somerville, W.B. (1963) Proc. Phys. Soc. 82, 446-455.

Stabler, R.C. (1964) Phys. Rev. 133, A1268-A1273.

Stauffer, A.D. and McDowell, M.R.C. (1964) Phys. Lett. 12 207-8.

\_\_\_\_\_ (1965) Proc. Phys. Soc. 85, 61-69.

\_\_\_\_\_ (1966) Proc. Phys. Soc. 89, 289-98.

St. John, R.M., Miller, F.C. and Lin, C.C. (1964) Phys. Rev. 134A, 888-97.

Bates, D.R., Kingston, A.E. and McWhirter, R.P.W. (1962)

Proc. Roy. Soc (London), A267, 297; A270, 155.

Landau & Lifschitz (1962) "Quantum Mechanics",

Volume III of "A Course of Theoretical Physics" (Pergamon)

Moore (1949) "Atomic Energy Levels, Vol I" (N.B.S.)

Rothman, C.C.J., Sachs, L.M., Weiss, A.W. (1960) Rev. Mod. Phys. 32, 186.



*Reprinted from*

*Proceedings of the  
Physical Society*

The Institute of Physics and the Physical Society  
Printed in Great Britain by J. W. Arrowsmith Ltd., Bristol 3

# Electron-impact-induced $n \rightarrow n'$ transitions in H atoms

K. M. PLUTA and M. R. C. McDOWELL

Mathematics Department, University of Durham

*MS. received 18th May 1966*

**Abstract.** A semi-classical impact parameter treatment with a cut-off is used to estimate the cross-sections for electron-impact-induced transitions between sets of levels of principal quantum numbers  $n$  and  $n'$  ( $n' > n$ ) in atomic hydrogen. The results are in closer accord at moderate and low energies with classical calculations based on Stabler's model than with those of Kingston, and agree closely with the Born approximation values at high energies, provided  $n' - n \leq 2$ .

## 1. Introduction

The process of collisional radiative recombination in plasmas may be studied in terms of the elementary atomic processes occurring (Bates and Dalgarno 1962). In hydrogen-like plasmas the resultant equations involve as parameters the cross sections for electron-induced transitions between groups of degenerate levels with principal quantum numbers  $n$  and  $n'$ . The values used for these have in the past been based on the classical formulae of Gryzinski (1959, 1965). Since for large  $n$  there are approximately  $nn'$  possible transitions between the groups of levels, detailed quantal calculations on all of these are scarcely possible even in Born's approximation. The classical values adopted cannot be correct at high energies in the absence of  $E^{-1} \log E$  terms in such expressions for the cross sections. Their overall validity has been estimated to be within a factor of 2, by comparison with Born calculations and available experimental data (Kingston 1964). In this paper we use the semi-empirical formulae developed by Stauffer and McDowell (1966, to be referred to as I) to calculate cross sections for several sets of values of  $n$  and  $n'$ , and compare these with Born and classical estimates.

## 2. Theory

Stauffer and McDowell (1966) show that in the impact parameter formulation of first-order time-dependent perturbation theory the cross section for a transition  $|\Gamma_1 L_1\rangle$  to another state  $|\Gamma_2 L_2\rangle$ , by electron impact at  $W_1$ , averaged over initial degenerate ( $M_{L_1}$ ) sub-states and summed over final degenerate sub-states, is

$$Q(W_1) = \frac{64\pi N^2}{(2L_1+1)} \left(\frac{W}{W_1}\right) \left(\frac{I_H}{\Delta E}\right)^2 \sum_{\lambda=1}^{\infty} \frac{1}{(2\lambda+1)^2} \frac{|\langle \Gamma_2 L_2 || \mathcal{Y}(\lambda) || \Gamma_1 L_1 \rangle|^2}{a_0^{2\lambda}} \times \left(\frac{\Delta E^2}{4I_H W}\right)^\lambda \sum_{\mu} \frac{\chi_{\mu}(\beta_0)}{(\lambda-\mu)!(\lambda+\mu)!} \pi a_0^2 \quad (1)$$

where the notation is established in I, and  $\beta_0$  depends on a cut-off  $R_0$ , the sensitivity to which is discussed in I.



When the atom or ion concerned is hydrogen-like this greatly simplifies. We note that (Edmonds 1957)

$$|\langle \Gamma_2 L_2 || \mathcal{Y}(\lambda) || \Gamma_1 L_1 \rangle|^2 \equiv \begin{pmatrix} l_1 & l_2 & \lambda \\ 0 & 0 & 0 \end{pmatrix}^2 |\langle \Gamma_2 l_2 M_{l_2} = 0 | \mathcal{Y}_{\lambda 0} | \Gamma_1 l_1 M_{l_1} = 0 \rangle|^2 \quad (2)$$

where  $|\Gamma_1 l_1 M_{l_1}\rangle$  is the  $n_1 l_1 M_{l_1}$  hydrogen-atom wave function and

$$\mathcal{Y}_{\lambda 0} = r^\lambda Y_{\lambda 0}(\theta, \phi) \quad (3)$$

in which  $(r, \theta, \phi)$  are the spherical polar coordinates of the active electron in a suitable reference frame. Thus

$$Q_{n_1 l_1, n_2 l_2}(W_1) = 2^4 \left(\frac{W}{W_1}\right) \left(\frac{I_H}{\Delta E}\right)^2 \sum_{\lambda} \frac{(2l_2 + 1) |g_{\lambda l_1 l_2}|^2}{2\lambda + 1} \times \begin{pmatrix} l_1 & l_2 & \lambda \\ 0 & 0 & 0 \end{pmatrix}^2 \left(\frac{\Delta E^2}{4I_H W}\right)^\lambda \sum_{\mu} \frac{\chi_{\mu}(\beta_0)}{(\lambda - \mu)!(\lambda + \mu)!} \quad (4)$$

where

$$g_{\lambda l_1 l_2} = \int_0^{\infty} r^{\lambda+2} R_{n_1 l_1}^*(r) R_{n_2 l_2}(r) dr \quad (5)$$

where  $R_{nl}(r)$  is the radial part of  $|\Gamma l M_l\rangle$ , normalized such that

$$\int_0^{\infty} r^2 |R_{nl}|^2 dr = 1. \quad (6)$$

Equation (4) is a poor approximation if  $l_1 = l_2$  (cf. I). We wish to calculate  $Q_{nn'}(W_1)$ , defined by

$$Q_{nn'}(W_1) = \frac{1}{n^2} \sum_{l'=0}^{n'-1} \sum_{l=0}^{n-1} (2l+1) Q_{nl, n'l'}(W_1). \quad (7)$$

Let

$$\tilde{Q}_{nn'}(W_1) = \frac{1}{n^2} \sum_{l'=0}^{n'-1} \sum_{l=0}^{n-1} (2l+1) \tilde{Q}_{nl, n'l'}(W_1) \quad (8)$$

where the prime indicates  $l \neq l'$ . Then suppose there exists a function  $f(W_1)$  such that

$$Q_{nn'}(W_1) = \{1 + f(W_1)\} \tilde{Q}_{nn'}(W_1) \quad (9)$$

and  $f(W_1)$  is independent of  $n, n'$ . We can check this by using Omidvar's (1965) Born calculations for (2, 3) and (3, 4) to calculate  $Q_{23}$ ,  $\tilde{Q}_{23}$ ;  $Q_{34}$  and  $\tilde{Q}_{34}$ . The resulting values of  $f(W_1)$  as a function of  $m = W_1/\Delta E_{nn'}$  are shown in figure 1. The known Born (Somerville 1963) values for the (1, 3) transitions yield somewhat lower values of  $f(W_1)$

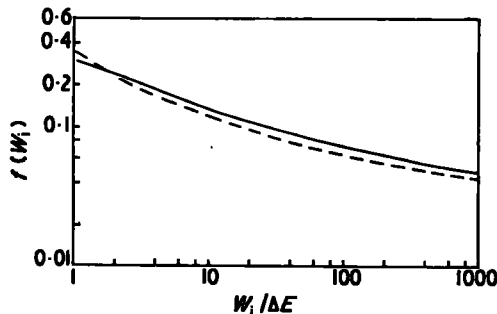

Figure 1. Calculated values of the function  $f(W_1)$  for the 2 → 3 and 3 → 4 sets of transitions: full curve, 3 → 4; broken curve, 2 → 3.

for  $m < 20$ , but the adopted values of  $f(W_1)$  given below are expected to be good to within 10% for transitions not involving the ground state ( $n = 1$ ), where the contribution from forbidden transitions is anomalously low.

Correction function  $f(m)$  calculated from Born cross sections

$m$	2	10	60	100	1000
$f(m)$	0.24	0.13	0.075	0.067	0.046

### 3. Results and discussion

The cross sections calculated using (4) and (9) are to be compared with the classical estimates of Kingston (1964), based on an approximation to Gryzinski's (1959) results,

$$Q_{nn'}^{(K)} \approx \frac{1}{8(n')^3 W_1 \Delta E_{nn'}^2} \left( \frac{W_2}{W_1 + E_n} \right)^{3/2} \left( \frac{7E_n - 3E_{n'}}{3\Delta E_{nn'}} - \frac{E_n}{W_1} \right) \quad (10)$$

for  $W_1 \gg 1$ . Asymptotically

$$Q_{nn'}^{(K)}(W_1) \underset{W_1 \rightarrow \infty}{\sim} \frac{1}{24W_1(n'\Delta E_{nn'})^3} (7E_n - 3E_{n'}). \quad (11)$$

Stabler (1964) has given an improved version of the Gryzinski model (in which the bound electrons have an energy distribution  $f(E) = \delta(E - E_1)$ ). For our case Stabler's result may be written (except in the neighbourhood of threshold)

$$Q_{nn'}^{(S)}(W_1) = \frac{1}{6W_1} \left( \frac{1}{\Delta E_{nn'}} - \frac{1}{\Delta E_{n,n'+1}} \right) \times \left\{ E_n \left( \frac{1}{\Delta E_{nn'}} + \frac{1}{\Delta E_{n,n'+1}} \right) + \frac{3}{2} \right\} \quad (12)$$

$$\underset{W_1 \rightarrow \infty}{\sim} \frac{1}{24W_1(n'\Delta E_{nn'})^3} \left\{ 7E_n - 3E_{n'} - \frac{3}{2n'^3} \left( \frac{2E_n}{E_n - E_{n'}} + 1 \right) \right\} \quad (13)$$

which will agree with Kingston's expression only if  $n'$  is large and  $n$  is small compared with  $n'$ . Both (10) and (12) have incorrect asymptotic behaviour ( $W_1^{-1}$ ) for large  $W_1$ .

The cross section  $Q_{nl,n'l'}(W_1)$  given by (4) may be calculated without difficulty, for a particular choice of  $R_0$ . We choose  $R_0 = r_a$  (see I and Stauffer and McDowell 1965). The sum  $Q_{nn'}(W_1)$  given by (7) is dominated at high energies by the contributions from the allowed transitions, and (Seaton 1962) these are individually in close accord with the Born values if for the  $i \rightarrow j$  transition the ratio  $f_{ij}/\Delta E_{ij}$  of the oscillator strength to the energy difference is large compared with unity. This is the case if  $\Delta n = n' - n$  does not exceed 2 (since in that case  $\Delta E_{nn'} \propto n^{-3}$  and  $f_{ij} \propto n^{-3}$  (Allen 1955)). For large  $\Delta n$  this ratio is proportional to  $n^{-1}$  and is normally small. Our method is therefore expected to be reliable for  $\Delta n = 1$  or 2 only, and this is verified by the detailed calculations.

In figure 2(a), (b) and (c) we compare  $Q_{nl,n'l'}(W_1)$  for all nine transitions of the  $n = 3, n' = 4$  set, for which  $\Delta l \neq 0$ , with the Born approximation calculations of McCoyd *et al.* (1960), also including their values for the  $\Delta l = 0$  cases for comparison. With the exception of 3d-4s,  $Q_{nl,n'l'}$  is always less than the Born value at low energies (where in any case the contribution of  $Q_{3d-4s}$  to  $Q_{3,4}$  is negligible) and approaches the Born value at high energies.

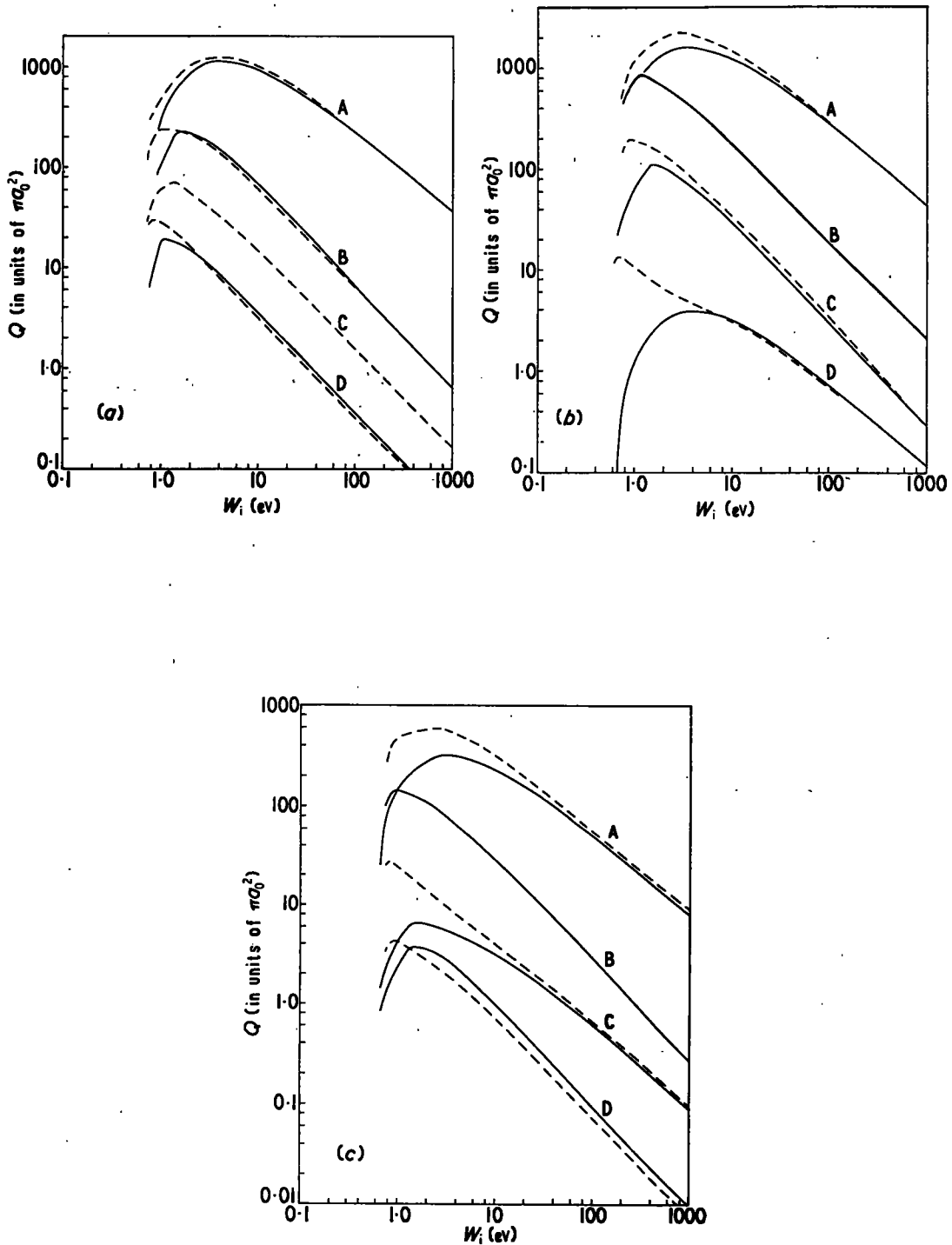

Figure 2. Cross sections for individual  $l \rightarrow l'$  transitions in the (3, 4) case calculated by the method of this paper (full curves) and in the Born approximation calculations (broken curves) of McCoy *et al.* (1960). (a) Curve A,  $10 \times Q_{s \rightarrow p}$ ; curve B,  $Q_{s \rightarrow d}$ ; curve C,  $\frac{1}{2} Q_{s \rightarrow s}$  (Born only); curve D,  $0.1 \times Q_{s \rightarrow f}$ . (b) Curve A,  $10 \times Q_{p \rightarrow d}$ ; curve B,  $5 \times Q_{p \rightarrow p}$  (Born only); curve C,  $\frac{1}{2} Q_{p \rightarrow f}$ ; curve D,  $\frac{1}{2} Q_{p \rightarrow s}$ . (c) Curve A,  $Q_{d \rightarrow f}$ ; curve B,  $Q_{d \rightarrow d}$  (Born only); curve C,  $Q_{d \rightarrow p}$ ; curve D,  $Q_{d \rightarrow s}$ .

In figures 3, 4 and 5 we give the ratios of  $Q$ ,  $Q^{(S)}$  and  $Q^{(K)}$  to the Born approximation values (McCoyd *et al.* 1960, Omidvar 1965†) for the (3, 4), (4, 6) and (4, 5) cases respectively. When  $\Delta n = 1$  neither classical approximation is as reliable as our method at energies above 0.5 rydbergs, while below this energy we are in much closer agreement with Stabler's model than with Kingston's, particularly at the extremely low impact

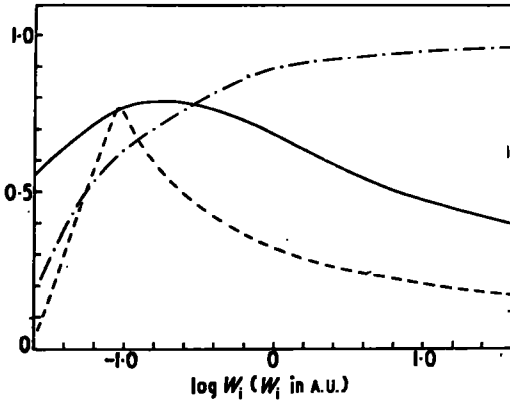

Figure 3. The ratios of  $Q_{nn}$ ,  $Q_{nn}^{(K)}$ ,  $Q_{nn}^{(S)}$  to  $Q_{nn}^{(B)}$  for the (3, 4) set of transitions, the three ratios being denoted by chain, full and broken curves respectively.

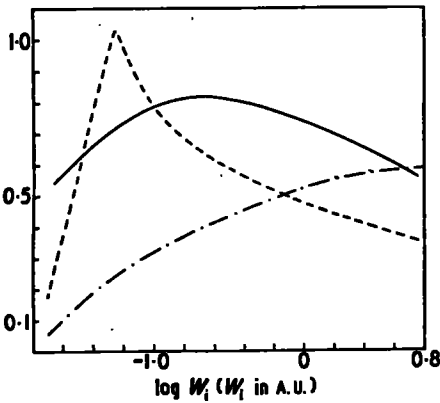

Figure 4. The same ratios for the (4, 6) set of transitions.

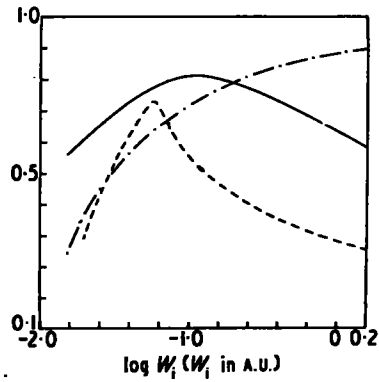

Figure 5. The same ratios for the (4, 5) set of transitions.

energies of interest in plasma applications. For  $\Delta n = 2$  transitions we approach Stabler's result closely in this region, and lie almost a factor of 10 lower than Kingston's values. We do not reproduce the large peak obtained in Stabler's model, which in any case is smoothed out, when his model is averaged over the correct classical energy distribution (McDowell 1966). We feel therefore that the uncertainty in Kingston's results at low energies may be much higher than his estimate of a factor of 2.

† Omidvar's values for  $Q_{4,5}(W_i)$  in the Born approximation are inconsistent, and have been smoothed to give a constant value of  $W_i Q(W)/\log W_i$  for large  $W_i$ . This value is 20% higher than that obtained from Fisher *et al.* (1960) who calculate only the allowed transitions. (See Kingston (1966) for comments on Omidvar's ionization results.) A referee has pointed out that the correct high-energy Born approximation values for  $Q_{4,5}(W_i)$  have been given by Kingston and Lauer (1966). Our results are in good agreement with these values, and the ordinate scale in figure 5 should be multiplied by approximately 1.2.

### Acknowledgments

One of us (K.M.P.) is indebted to the Science Research Council for a research studentship.

### References

- ALLEN, C. W., 1955, *Astrophysical Quantities* (London: Athlone Press).  
BATES, D. R., and DALGARNO, A., 1962, *Atomic and Molecular Processes* (New York: Academic Press).  
EDMONDS, A. R., 1957, *Angular Momentum in Quantum Mechanics* (Princeton: Princeton University Press).  
FISHER, L., MILFORD, S. N., and ROMILLA, F. R., 1960, *Phys. Rev.*, **119**, 153-5.  
GRYZINSKI, M., 1959, *Phys. Rev.*, **115**, 374-83.  
— 1965, *Phys. Rev.*, **138**, A336-58.  
KINGSTON, A. E., 1964, *Phys. Rev.*, **135**, A1529-36.  
— 1966, *Proc. Phys. Soc.*, **87**, 193-200.  
KINGSTON, A. E., and LAUER, J. E., 1966, *Proc. Phys. Soc.*, **87**, 399-405.  
MCCOYD, G. C., MILFORD, S. N., and WAHL, J. J., 1960, *Phys. Rev.*, **119**, 149-53.  
MCDOWELL, M. R. C., 1966, *Proc. Phys. Soc.*, **89**, 23-26.  
OMIDVAR, K., 1965, *Phys. Rev.*, **140**, A38-46.  
SEATON, M. J., 1962, *Proc. Phys. Soc.*, **79**, 1105-17.  
SOMERVILLE, W. B., 1963, *Proc. Phys. Soc.*, **82**, 446-55.  
STABLER, R. C., 1964, *Phys. Rev.*, **133**, A1268-73.  
STAUFFER, A. D., and MCDOWELL, M. R. C., 1965, *Proc. Phys. Soc.*, **85**, 61-9.  
— 1966, *Proc. Phys. Soc.*, **89**, 289-98.

# Proton impact excitation of the $n$ <sup>1</sup>D states of He

M. R. C. McDOWELL and K. M. PLUTA

Mathematics Department, University of Durham

*MS. received 22nd March 1966*

**Abstract.** The impact parameter version of Born's approximation is used to calculate cross sections for proton impact excitation of the  $n$  <sup>1</sup>D states of He ( $n = 3, 4$ ) from 1 <sup>1</sup>S and 2 <sup>1</sup>P. The results for 1 <sup>1</sup>S  $\rightarrow$  4 <sup>1</sup>D are in satisfactory accord with experiment.

## 1. Introduction

Several calculations on

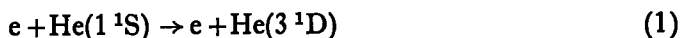

have been reported (Massey and Mohr 1933, Fox 1966). Fox's recent paper points out that large uncertainties occur owing to the approximate nature of the atomic wave functions employed and, further, he finds that for a given wave function equivalent formulations of the matrix element may change the results by 50% (cf. Stauffer and McDowell 1964). Fox uses the wave formulation of Born's approximation, and finds that his adopted values lie a factor of 2 below the reported absolute experimental results of Heddle and Lucas (1963) (normalized to the value at 108 eV of Gabriel and Heddle (1960)) and of St. John *et al.* (1964) which agree among themselves to within 30%. Inclusion of the intermediate 3p state has little effect on the calculated values.

It is of interest to examine the situation for proton impact. In this case the impact parameter version of Born's approximation may be used, and is equivalent to the wave treatment at energies above a few tens of volts for total cross sections (Moiseiwitsch 1966, Crothers and Holt 1966, McCarroll and Salin 1966).

We employ it to calculate cross sections for the processes

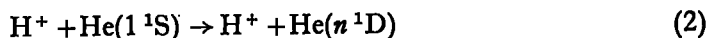

and

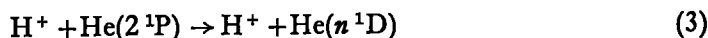

for  $n = 3$  and 4.

## 2. Theory

We assume that the incident proton passes at an impact parameter  $\rho$  and constant velocity  $\mathbf{v}$  from the target atom. The cross section  $Q_{if}(\mathbf{v})$  for excitation from an initial state  $i$  to a final state  $f$  is

$$Q_{if}(\mathbf{v}) = 2 \int_0^\infty P_{if}(\rho, \mathbf{v}) \rho \, d\rho (\pi a_0^2) \quad (4)$$

where

$$P_{if}(\rho, \mathbf{v}) = \frac{N^2}{2L_i + 1} \sum_{M_i, M_f} \left| \int e^{i\mathbf{v}t} \langle L_i, M_i | V | L_f, M_f \rangle dt \right| \quad (5)$$

on averaging over initial ( $M_{L_i}$ ) and summing over final ( $M_{L_f}$ ) substates. Here

$$V = \frac{1}{R} - \frac{1}{r} \quad (6)$$

where  $R$  is the incident proton-nucleus distance, and  $r$  the incident proton-active-electron distance, while  $N$  is the number of electrons and  $p$  is the energy difference between final and initial states. The wave functions are chosen to be of the form

$$\begin{aligned} |1^1S\rangle &= \frac{N_0}{\sqrt{2}}\{\psi_{1s}(\gamma, 1)\psi_{1s}(\delta, 2) + \psi_{1s}(\gamma, 2)\psi_{1s}(\delta, 1)\} \\ |2^1PM_L\rangle &= \frac{1}{\sqrt{2}}\{\psi_{1s}(2, 1)\psi_{2pm_i}(1, 2) + \psi_{1s}(2, 2)\psi_{2pm_i}(1, 1)\} \\ |n^1DM_L\rangle &= \frac{1}{\sqrt{2}}\{\psi_{1s}(2, 1)\psi_{ndm_i}(1, 2) + \psi_{1s}(2, 2)\psi_{ndm_i}(1, 1)\} \end{aligned} \quad (7)$$

where  $\psi_{nlm_i}(Z, i)$  is an  $nlm_i$  hydrogenic function of effective nuclear charge  $Z$  for electron  $i$ , and  $N_0$  is a normalization constant. We take  $\gamma = 2.14$ ,  $\beta = 1.19$  (Eckhart 1930), in agreement with Fox, for the ground state. The quantum defects for  $2^1P$ ,  $3^1D$  and  $4^1D$  are small, so that (7) should provide an accurate representation for the excited states for the purpose of this paper.

The method is essentially the same as that of Bell (1961) who studied

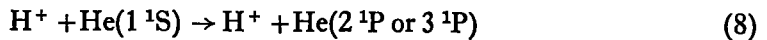

and need not be described in detail. The matrix elements involved are of the form

$$V_{a,b} = \int d\mathbf{r}_1 \psi_a^*(\mathbf{r}_1) \frac{1}{|\mathbf{r}_1 - \mathbf{R}|} \psi_b(\mathbf{r}_1)$$

where  $\psi_a, \psi_b$  are hydrogenic wave functions, and may be transformed by the Fourier involution theorem to

$$V_{a,b} = \frac{4\pi}{K^2} \int e^{i\mathbf{K}\cdot\mathbf{R}} g_{a,b} d\mathbf{K} \quad (9)$$

where

$$g_{a,b} = \int e^{-i\mathbf{K}\cdot\mathbf{r}} \psi_a^*(\mathbf{r}) \psi_b(\mathbf{r}) d\mathbf{r}.$$

The transition probability  $P_{ij}(\rho, v)$  is then a sum of squares of terms of the form

$$A_{a,b} = \int_{-\infty}^{\infty} e^{-ipz/v} \int \frac{e^{i\mathbf{K}\cdot\mathbf{R}}}{K^2} g_{a,b} d\mathbf{K} dZ. \quad (10)$$

On putting  $\mathbf{R} = \boldsymbol{\rho} + \mathbf{v}t$  and choosing  $\mathbf{v}$  along the  $Z$  axis, the  $g_{a,b}$  integrals are reduced by transforming the wave functions to a frame with polar axis along  $\hat{\mathbf{K}}$ , while the remaining integral in (10) may be evaluated by noting that

$$\mathbf{K} \cdot \mathbf{R} = K_z \rho + K_z Z$$

while

$$\int_{-\infty}^{\infty} \exp\left(-\frac{i\rho Z}{v} + iK_z Z\right) dZ = 2\pi\delta\left(K_z - \frac{\rho}{v}\right) \quad (11)$$

which reduces it to a two-dimensional integral over  $K_x$  and  $K_y$ . The resulting expressions for the ( $M_{L_i}, M_{L_f}$ ) components of  $P_{if}(\rho_1 v)$  are lengthy, especially for the  $2^1P \rightarrow n^1D$  case, and are given elsewhere (Pluta 1966, M.Sc. Thesis, University of Durham).

### 3. Results and discussion

The integrals  $A_{a,b}$  were reduced to the form

$$A_{a,b} = \frac{1}{\pi v} \int_0^{\infty} dK_x \int_0^{\infty} dK_y \cos(K_x \rho) f_{a,b}(K_x, K_y)$$

and after changing the variable to  $X = K_x \rho$ , evaluated by a double Gauss-Laguerre quadrature, the final integration over impact parameter being carried out by a 31-point repeated Simpson rule. For  $1^1S \rightarrow n^1D$  significant contributions occurred only for  $\rho < 5a_0$  except for  $M_{L_i} = 0$  when they arose from  $\rho < 7a_0$ . In the  $2^1P \rightarrow n^1D$  case all ( $M_{L_i}, M_{L_f}$ ) integrals gave significant contributions for  $\rho$  as large as  $15a_0$ . The cross sections for  $2^1P \rightarrow n^1D$  ( $n = 3, 4$ ) were evaluated for comparison with those obtained with the same wave functions, but using an impact parameter method with a cut-off, by Stauffer and McDowell (1966). Stauffer and McDowell's work refers to electron impact, but above ten times threshold the cross sections are close to those for protons of the same velocity. Both sets of results are shown in table 1 and, considering the simplicity of the cut-off method, are in remarkably good agreement.

Table 1. Cross sections ( $\pi a_0^2$ ) for proton-impact excitation of the  $2^1P \rightarrow n^1D$  transitions

$E$ (keV)	$3^1D$		$4^1D$	
	(1)	(2)	(1)	(2)
31.25	10.3	6.1	1.64	1.11
62.5	5.69	4.1 <sub>1</sub>	8.71 <sup>-1</sup>	8.2 <sup>-1</sup>
93.8	3.91	3.0 <sub>5</sub>	5.93 <sup>-1</sup>	6.3 <sub>6</sub> <sup>-1</sup>
125	2.97	2.4 <sub>6</sub>	4.50 <sup>-1</sup>	5.2 <sup>-1</sup>
188	2.01	1.7 <sub>6</sub>	3.03 <sup>-1</sup>	4.0 <sub>2</sub> <sup>-1</sup>
250	1.52	1.3 <sub>7</sub>	2.28 <sup>-1</sup>	3.2 <sub>2</sub> <sup>-1</sup>

(1) this paper, (2) Stauffer and McDowell 1966 (see text).

The superscript indicates the power of 10 by which the number is to be multiplied.

Table 2. Cross sections ( $\pi a_0^2$ ) for proton-impact excitation of the  $1^1S \rightarrow n^1D$  transitions

$E$ (keV)	31.25	62.5	93.8	125	250	375
$Q(3^1D)$	3.55 <sup>-3</sup>	3.24 <sup>-3</sup>	2.69 <sup>-3</sup>	2.27 <sup>-3</sup>	1.39 <sup>-3</sup>	1.00 <sup>-3</sup>
$Q(4^1D)$	1.87 <sup>-3</sup>	1.72 <sup>-3</sup>	1.43 <sup>-3</sup>	1.21 <sup>-3</sup>	7.33 <sup>-4</sup>	5.30 <sup>-4</sup>

The superscript indicates the power of 10 by which the number is to be multiplied.



The results for  $1^1\text{S} \rightarrow n^1\text{D}$  ( $n = 3, 4$ ) are displayed in table 2. They must be regarded as uncertain by as much as a factor of 2, as the quadrupole matrix element

$$R_{11}^{(2)} = \frac{4\pi N^2}{5} \sum_{\mu} |\langle \psi_f | r^2 Y_{2\mu}(\hat{\mathbf{r}}) | \psi_i \rangle|^2$$

which controls their magnitude is quite sensitive to the choice of initial-state wave function and to the choice of equivalent 'length' or 'velocity' formulations (Stauffer and McDowell 1964). Stauffer and McDowell (1964) found that for  $1^1\text{S} \rightarrow 3^1\text{D}$  it ranged from 0.021 to 0.129 (the formulation adopted here corresponding to the latter value) with a probable value of 0.062, depending on the choice of wave functions, while for  $1^1\text{S} \rightarrow 4^1\text{D}$  it ranged from 0.011 to 0.060 (the latter value corresponding to the functions used in this paper) with a probable value of 0.032. A similar variation is apparent in the matrix element  $f(0)$  occurring in Fox's work (Fox 1966). Again the choice of wave function made by Fox (and by us) corresponds to the highest calculated value.

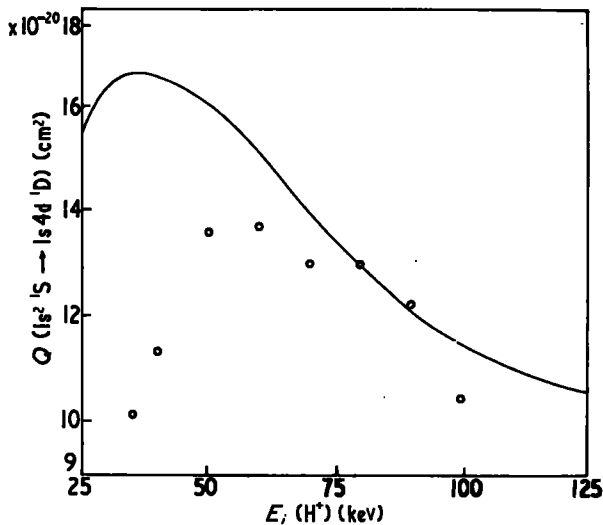

Cross sections for  $\text{H}^+ + \text{He}(1^1\text{S}) \rightarrow \text{H}^+ + \text{He}(4^1\text{D})$ : full curve, this paper; circles, de Heer and van den Bos 1966.

Our calculated values for  $Q(1^1\text{S} \rightarrow 4^1\text{D})$  are compared in the figure with recent experimental values of de Heer and van den Bos (1966). The reported experimental value at 100 keV is probably too low, since it would indicate an unacceptably high rate of fall-off of cross section with increasing impact energy. Ignoring this value and the uncertainty in our computed values the agreement with experiment is satisfactory. A comparison with the electron-impact results of Fox at equivalent velocities indicates that for  $3^1\text{D}$  our results at six times threshold energy (electron-impact scale) are almost a factor of 2 higher, but would appear to join smoothly to a reasonable extrapolation of his curve at about fifteen times threshold. Above 100 eV equivalent energy, while the  $4^1\text{D}$  results are in reasonable agreement with the proton impact measurements of de Heer and van den Bos, they lie a factor of 2 below the reported electron-impact measurements. Further experimental work on electron-impact excitation of the  $n^1\text{D}$  states would appear desirable.

## Acknowledgments

We are indebted to Dr. F. J. de Heer for permission to use his results before publication. One of us (K.M.P.) was supported by a Science Research Council studentship.

## References

- BELL, R. J., 1961, *Proc. Phys. Soc.*, **78**, 903-11.  
CROTHERS, D. S. F., and HOLT, A. R., 1966, *Proc. Phys. Soc.*, **88**, 75-81.  
ECKHART, C., 1930, *Phys. Rev.*, **36**, 878-92.  
FOX, M. A., 1966, *Proc. Phys. Soc.*, **88**, 65-9.  
GABRIEL, A. H., and HEDDLE, D. W. O., 1960, *Proc. Roy. Soc. A*, **258**, 124-45.  
HEDDLE, D. W. O., and LUCAS, C. B., 1963, *Proc. Roy. Soc. A*, **271**, 129-42.  
DE HEER, F. J., and VAN DEN BOS, J., 1966, *Physica*, in the press.  
MASSEY, H. S. W., and MOHR, C. B. O., 1933, *Proc. Roy. Soc. A*, **140**, 613-36.  
MCCARROLL, R., and SALIN, A., 1966, *C.R. Acad. Sci., Paris*, in the press.  
MOISEWITSCH, B. L., 1966, *Proc. Phys. Soc.*, **87**, 885-8.  
ST. JOHN, R. M., MILLER, F. L., and LIN, C. C., 1964, *Phys. Rev.*, **134**, A888-97.  
STAUFFER, A. D., and MCDOWELL, M. R. C., 1964, *Phys. Letters*, **12**, 207-8.  
——— 1966, *Proc. Phys. Soc.*, **89**, 289-98.