



# Durham E-Theses

---

## *Planning maternity care*

Porter, A. M. D

### How to cite:

---

Porter, A. M. D (1971) *Planning maternity care*, Durham theses, Durham University. Available at Durham E-Theses Online: <http://etheses.dur.ac.uk/9555/>

### Use policy

---

The full-text may be used and/or reproduced, and given to third parties in any format or medium, without prior permission or charge, for personal research or study, educational, or not-for-profit purposes provided that:

- a full bibliographic reference is made to the original source
- a [link](#) is made to the metadata record in Durham E-Theses
- the full-text is not changed in any way

The full-text must not be sold in any format or medium without the formal permission of the copyright holders.

Please consult the [full Durham E-Theses policy](#) for further details.

## ABSTRACT

This thesis demonstrates the potential of 'inverse-programming' - a technique adapted from linear-programming - as an aid to planning the provision of medical care services for the next three to five years. In order to minimise the definition and measurement problems inherent in all economic analyses of medical care, maternity services provided within Sunderland County Borough were used in the investigation as a simplified version of a health service. It is suggested that the next stage will be to apply the technique to 'Area Health Board' planning.

Chapter 1 provides a background picture of the present pattern of providing maternity care in England and Wales, and Sunderland County Borough; and Chapter 2 goes on to examine certain factors associated with the quality of maternity care services in terms of mortality rates and the use made of the available services.

Chapter 3 introduces the basic ideas of 'inverse-programming' and describes a model of a hypothetical maternity hospital providing only two services. It shows how the trade-offs implicit in the decisions taken by administrators can be made explicit by using the observed production technology and activity levels to predict the range of weights defined by the slopes of those resource constraints which are limiting further expansion. First approximations of these relative benefits were derived from short-run unit costs.

These ideas are then employed in Chapter 4 for the planning of Sunderland County Borough's maternity services - first as a descriptive tool to make the administrators' estimates of relative benefit explicit, and then as a means of simulating changes, suggested by Chapter 2, in resource levels, the technology, and in planners' priorities.

PLANNING MATERNITY CARE

A Study into the Quality of Maternity Care,  
and the Use of an Economic Model as an Aid  
to Planning Future Provision in Sunderland  
County Borough

A.M.D. PORTER

University of Durham

Thesis Submitted for the Degree of  
Master of Philosophy, 1971

## ACKNOWLEDGEMENTS

I would like to thank all those people responsible for the provision of maternity care services in Sunderland County Borough for their tolerance and goodwill when I was collecting the material required by this thesis.

'In considering the service aspects of maternity care, the problems that present themselves resolve into three interdependent groups: demand, selection and supply. It might seem that the quality of the maternity services might be judged on the sole basis of evaluating the demand made upon it and the degree of success attained in meeting such demand. But this would be adequate only if it was certain that the demand expressed fully represented the need of the customer. In the context of the National Health Service, the customer's need is processed by medical and other authorities in accordance with certain criteria of selection for place of confinement. Demand, therefore, as it finally appears, is an interplay of customers' wishes and process of selection: both elements must be considered together. But both, in turn, are conditioned by the supply of available resources: not only in terms of the number of doctors, midwives, ancillary staff and the quantities of equipment and accommodation, but also - and less easily measured - the restriction placed upon their supply by the facts of their location and the periods of time within which they can be made ready for use and for which they can be allocated to the individual customer.'

R. SHEGOG, 1966.

## CONTENTS

INTRODUCTION	i-vi
CHAPTER 1	1
Review of Maternity Service Provision Since 1946	
Diagram 1	14
Map	17/18
Tables and Graphs	26
CHAPTER 2	28
Assessing the Quality of Maternity Services	
Tables and Graphs	63
CHAPTER 3	66
Planning the Supply of Maternity Services	
Figures and Tables	83
CHAPTER 4	86
Planning the Supply of Maternity Services to Sunderland County Borough	
Tables 1-13	In Text
Figures 1 and 2	120
CONCLUSION	121
APPENDIX	130
Derivation of the Technology Matrix	
Tables 1-10	154
BIBLIOGRAPHY	165

## INTRODUCTION

The foundation of the National Health Service was based largely on the principle of free access to medical care for all those in 'need' rather than with the 'ability to pay', and this principle is generally accepted to be as true today as it was in 1946. However, where the official estimates of health service expenditure in the Beveridge Report calculated that costs would not rise over the coming years (a prediction based on the expected feasibility of preventive medicine), the rapid increase in total health service expenditure caused considerable alarm amongst politicians and the general public, and led to government pressure for greater economy.

More recently, dissatisfaction from both within and without the service over decreasing standards of quality has forced the government and health service administrators to think not so much in terms of economies but of priorities. Because of, rather than in spite of, the major advances in medical research and treatment, the demand for medical care has increased year by year, although there have been some notable decreases in the incidence of certain diseases (for example, Tuberculosis, Poliomyelitis, and Rheumatic Fever). Moreover, it is recognised that the slow growth rate of the British economy and the demands of other public services upon the/

the Exchequer's purse prevent any radical redistribution of funds to the health sector: 'It would be quite wrong, morally as well as factually, to expect greatly increased financial resources to be made available for health in the early future.' [Butterfield, 1968].

Instead of being able to provide a comprehensive health service, administrators have increasingly been forced to distribute the resources they have amongst a growing number of beneficial but expensive medical services. This modern medical dilemma has recently been summarised as 'the insoluble equation of matching the wants of the people with 'needs' as defined by professional planners, and with resources in terms of money, buildings and professional personnel. The challenge facing us all is how to make the best use of medical resources in order to provide the highest possible quality of personal care.' [Royal College of General Practitioners, 1970]. In recent years, economists and operational researchers have become interested in the problems associated with health service efficiency, and this thesis is an investigation into all three aspects of this 'insoluble equation'.

Health services provide particular problems to the administrator and economist. In the first place, efficient planning requires knowledge of what is being produced. The definition/



definition and measurement of health service output is complicated by the heterogeneity of case types, diagnoses and treatments so that there is little reliable information concerning final output. The definition of hospital output has proved difficult enough (Feldstein, 1967; Baligh and Laughhunn, 1969), and its extension to health services including hospital, local authority and general practice services makes any workable definition even more complex.

Secondly, measurement of the actual production process is complicated not only by the heterogeneity of output but also by variations in resource utilisation. There may be little consistency in the relationships between resources and outputs.

Finally, there are no market prices to help determine the value of what is being produced. Where the criterion for future planning of a commercial enterprise may be explicit and quantitative (for example, maximise profits), it is likely that the non-market industry seeks to achieve a qualitative criterion (minimise the risk of ill-health to the community, or maximise the health of the community), subject to a budget constraint. The problem is that there is no direct way of measuring the comparative value of different health service activities.

Sunderland County Borough's maternity services were chosen as the object of study in order to reduce the definition and measurement problems. The output from maternity services is fairly homogeneous and specific (maternity patients are immediately identifiable and the patterns of care can be categorised into mutually exclusive activities), and it is an area where the hospital and Local Health Authority boundaries did not cause too many measurement complications. By minimising these difficulties, it was possible to concentrate on the problem of making explicit and quantitative the qualitative criterion by which health service decision-makers plan future supply.

Chapters 1 and 2 examine some of the qualitative aspects of an efficient maternity service. After a brief review of the pattern of maternity service provision, there is an analysis of the needs of expectant mothers in terms of mortality risk to themselves and their babies. Having established certain medical and social criteria by which the present usage-rates of maternity services might be evaluated, certain areas of qualitative inefficient provision are determined, and factors associated with this inefficiency investigated - mothers' attitudes to antenatal care and place of confinement, and doctor/midwife opinions.

In the light of this qualitative analysis, Chapters 3 and 4 present/

present an economic model to assist maternity service administrators with their short and medium run planning.

Industries working in competitive market conditions have for some years used linear-programming to help determine the most efficient deployment of resources. Taking as given the constraints imposed by the availability of these resources, the technology describing the levels of resources required by a unit of output, and the profit function which is the criterion for future planning, linear-programming will not only calculate the blend of output levels that will make the most profit from the available resources, but will also indicate how much extra profit could be made if resource levels could be adjusted, the technology amended, or if relative profit per unit of output changed.

The health service planner, in spite of the definition and measurement problems outlined above, should have information pertaining to present levels of output and the technology, but is forced, because of the lack of quantitative criteria, to base his planning on intuitive estimates of the relative values of the services provided. The model proposed here reverses the reasoning of traditional linear-programming. Instead of using the criterion and the technology to determine the optimum blend of output, this model assumes that the blend of output actually provided was optimal, and uses this, together with the technology employed/

employed in the production of this observed blend, to make these estimates explicit.

To assume that the blend of output levels was optimal in the technical sense is reasonable because, except in times of major change, the administrator has had time to adjust resource levels to the point where there are no important resources lying idle.

Having determined the relative values on the objective function which would have led to the actual levels of output being predicted, traditional linear-programming is used to predict the effects of changes in resource levels, the technology, and in doctors' preferences.

## CHAPTER 1

### REVIEW OF MATERNITY SERVICE PROVISION SINCE 1946(\*)

'The provision of maternity services has been extended by successive legislation culminating in the National Health Service Act of 1946 which secured for the first time the availability of complete maternity care for all women. Services concerned with antenatal and postnatal care and delivery, in common with other health services, then became shared between general practitioners, hospitals and local health authorities, and a variety of patterns of care developed, according to local circumstances. The resulting tripartite administration has proved a difficult framework for the efficient administration of maternity services'.

Peel Report.

Apart/

(\*) : A detailed review of the maternity services was commissioned in 1956, and published as the Cranbrook Report [Ministry of Health, 1959]. More recently, a report on 'Domiciliary Midwifery and Maternity Bed Needs' has been prepared by the Sub-Committee of the Standing Maternity and Midwifery Advisory Committee [Department of Health and Social Security, 1970], henceforth referred to as the Peel Report.

Apart from some minor changes in policy and organisation, the general pattern of provision of maternity services has remained unchanged since the National Health Service came into operation in 1948.

A. Services Provided by the Regional Hospital Boards:

The Regional Hospital Boards (and the Boards of Governors of Teaching Hospitals) plan the provision of accommodation for hospital confinement and of specialist services. Through local planning by the smaller Hospital Management Committees, the Boards provide out-patient clinics for antenatal and postnatal care, and maternity beds for antenatal in-patient, delivery and postnatal lying-in care.

The proportion of women receiving confinement care in hospital rose from 52.8% of total confinements in 1947 to 64.2% in 1959 - the year of the publication of the Cranbrook Report which recommended that 'provision should be made over the country as a whole of a sufficient number of maternity beds to allow for an average of 70% institutional confinements, with the assumption that the normal period of stay in hospital after delivery will be ten days'. [Ministry of Health, 1959, paragraph 167]. The Cranbrook target figure of 70% was reached in 1965, and has continued to rise so that in 1968 the total institutional confinement rate reached 80.8%. (See Table and Graph I, Page 26).

This/

This rapid increase in the proportion of women receiving confinement care in hospital has been accompanied by a reduction in the normal period of stay post-delivery, the introduction of early-discharge schemes keeping the mother in hospital for only 48 hours, and an increase in the total number of consultant and general practitioner beds. From 1955 to 1968, the average length of postnatal stay for all hospitals fell from 11.0 days to 6.6 days, and the percentage of women with postnatal stay in hospital of 2 days or less rose from 4.9% in 1958 to 14.4% in 1968. The total number of consultant beds rose by 7.3% from 1955-1968, and the total number of general practitioner beds by 82.8%<sup>(\*)</sup>. As these trends are expected to continue, it is not surprising to find Cranbrook's recommendations giving way to a policy aiming at 100% institutional confinement: 'We consider that the resources of modern medicine should be available to all mothers and babies, and we think that sufficient facilities should be provided to allow for 100% hospital delivery. The greater safety of hospital confinement for mother and child justifies this objective'.

Department of Health and Social Security, 1970, paragraph 277.

The only factor seemingly capable of denying this objective would be/

(\*) : Source : Report of Chief Medical Officer of Health 'On the State of the Public Health for 1968', Department of Health and Social Security, 1969a.

be a sudden increase in the birth-rate - similar to that lasting from 1955-1964. (See Graph I, Page 26).

It should be pointed out that there are local authority areas where the hospital confinement rate in 1968 was as low as 60% of total confinements, whilst there were others already approaching 100% institutional confinement. Similarly there are considerable regional variations in birth-rate, and Golding has suggested that because of the difficulty of accurate prediction, maternity units should be built so that some of the beds might be used for other specialties, and that isolated maternity units should not be built. [Golding, 1967].

The antenatal care of women booked for hospital confinement is usually undertaken, in part, by the hospital out-patient clinic. However, the trend in recent years has been for hospitals to delegate more of the antenatal (and postnatal) care of patients to their general practitioners. In this way, the hospital can allocate its scarce resources to providing specialist rather than routine care - the general practitioner providing the routine care in the knowledge that specialist care is available if a patient's condition requires it. However, 'The disadvantages of divided responsibility are perhaps of greatest importance during the period of antenatal surveillance, when the exchange of information on the patient's condition may be vital'. [Department of Health and Social Security, 1970, paragraph 807].



Hospitals also keep a proportion of beds available for antenatal in-patient care. On the basis of the high perinatal mortality rate<sup>(\*)</sup> compared with some other countries, and the avoidable factors revealed in the Confidential Enquiries into Maternal Deaths [Department of Health and Social Security, 1969b], the Peel Report stressed the need for greater attention to in-patient antenatal care and recommended that 'The proportion of beds used for antenatal care should not be less than 25% of all maternity beds' [Department of Health and Social Security, 1970, paragraph 285(b)(ii)].

Finally, as part of their specialist service, laboratory and x-ray facilities are available to all maternity patients, and major maternity hospitals also provide emergency obstetric services (flying-squads), and special baby-care units.

**B. Services Provided by the General Practitioners:**

The family doctor is largely responsible for ensuring that a woman on his list receives all proper and necessary treatment throughout her pregnancy, confinement and postnatal period. He is also responsible for:

(a) attending at an emergency in connection with the pregnancy if the practitioner is summoned on behalf of the patient;

(b)/

(\*) : Stillbirths and deaths less than one week old per 1,000 total live and stillbirths.

- (b) attending if summoned by the midwife;
- (c) the issue, to the person or her personal representative, of certificates of pregnancy, expected confinement and confinement.

The nature of maternity medical services provided by general practitioners has changed since 1962 when payment was made for complete services in 306,574 cases and part services in a further 338,204 (including miscarriages) in England and Wales. In 1968, the comparable figures were 280,168 and 449,597. 'These figures reflect the increasing extent to which hospitals delegate to general practitioners some of the antenatal and postnatal care of patients delivered in hospital.' Department of Health and Social Security, 1970, paragraph 65.

All general practitioners may provide maternity medical services to their own patients, but the majority of such services is provided by general practitioners who have special qualifications and have been accepted onto the 'Obstetric List'<sup>(\*)</sup>. About 77% of all general practitioners are on such lists and they receive special fees for services provided. In 1968, only 3,161 (1.1%) complete services and 15,892 (3.5%) part services were given by doctors not on the obstetric list.

Apart from providing antenatal and postnatal care at their own/

(\*) : This only applies to England and Wales.

own (and/or at local health authority) clinics, and attending home deliveries with the domiciliary midwife<sup>(\*)</sup>, general practitioner obstetricians (doctors on the Obstetric List) have had an increasingly important part to play as providers of general practitioner unit confinement care.

The Cranbrook Report recommended that all general practitioner obstetricians should have access to general maternity beds, and that these should be within or very close to consultant maternity hospitals or general hospitals with maternity departments. It also suggested that a consultant obstetrician should have overall responsibility for supervision of general practitioner beds. In 1955, general practitioner beds constituted only 13% of the total number of maternity beds in National Health Service hospitals, but by 1968 this had risen to 21% of the total of 23,035 maternity beds<sup>(I)</sup>. However, 80% of 5,102 general practitioner beds were in units completely separate from consultant facilities, and a recent report/

(\*) : In 1968, a doctor was booked for 98% of domiciliary confinements attended by midwives, and was present at the delivery of 22% of such cases.

Of the 2% domiciliary confinements where the doctor was not booked, a doctor was present at 15% of such cases.

(I) : Source : Department of Health and Social Security, 1970, paragraph 106.

report of the Royal College of Obstetricians and Gynaecologists has recommended the closing of isolated general practitioner units in the interests of safety, and the integration of general practitioner and consultant units with common delivery suites and facilities, and with the general practitioner obstetrician working as a member of the hospital team. The Peel Report agreed with these findings and recommended that 'The links between separate general practitioner units and consultant units need to be improved.' [Department of Health and Social Security, 1970, paragraph 285, (c), (vi)].

Not only may isolated general practitioner units be unsafe, they may also be unnecessarily inefficient. Broad comparisons between the average length of stay for general practitioner beds and consultant beds have understandably shown that general practitioners keep their patients in hospital for shorter lengths of stay than consultants (see Reports of Chief Medical Officer of Health 'On the State of the Public Health'). As consultant units specialise in problem cases, this is not particularly surprising. However, it has been shown that general practitioners working in units isolated from consultant units keep normal cases (\*) in hospital for significantly longer stays than general practitioners/

(\*) : 'Normal Cases' as defined by 4-digit International Standard Classification 660.0 is one in which there is no complication of pregnancy, delivery or puerperium.

practitioners with special consultant attachments. Summing up his findings from a study of 'duration of stay by doctor-hospital combination' in the Oxford region, Feldstein concludes: 'The ten-day stay represents a low-risk 'norm' of good practice that is easily applied to nearly all cases. Because each doctor cares for only a few patients, this duration of stay policy does not reflect a concern to make the best use of the available beds. The opposite conclusions apply to the consultant obstetricians. As a result, the general practitioner group in close relation to a consultant has substantially shorter stays than the other general practitioner groups.' [Feldstein, 1967, page 249].

C. Services Provided by the Local Health Authorities:

Every Local Health Authority has the 'duty' to ensure that an adequate number of midwives is available in their area to attend women confined in their homes, and has the power to provide for attendance on women elsewhere than in their homes or in National Health Service hospitals. A Local Health Authority may also arrange for the services of midwives employed in its area to be made available to another Local Health Authority. In this way<sup>(\*)</sup>, some flexibility/

(\*) : Section 10 of the Health Services and Public Health Act 1968 removed most of the legal limitations to the employment of Local Health Authority domiciliary midwives elsewhere than in the patient's own home.

flexibility in the allocation of midwives has been achieved.

Together with the general practitioner, domiciliary midwives provide specially qualified 'care for women during pregnancy, delivery, and the postnatal period, and for the newly born infant. This care includes preventive measures, health education, the detection of abnormal conditions in mother and child, the procurement of medical assistance and the execution of emergency measures in the absence of medical help'. World Health Organisation, Moscow Conference. Domiciliary clinics staffed by midwives also offer Mothercraft and Relaxation classes, and Family Planning Advice. (The Peel Report also recommended that hospital clinics should play an important role as Family Planning Clinics as they are becoming more responsible for maternity care).

With the reduction in the total number of home deliveries since 1962, there has been a considerable change in the pattern of provision of midwifery services, for not only has the proportion of home deliveries decreased, but the average length of stay for hospital deliveries has also fallen.

Thus, although the ratio of midwives to total home confinements has risen from 1.2 per 100 home deliveries to 2.2 per 100 over the past ten years as the total number of home confinements has fallen, this increase does not imply a rise in the number of midwife hours per home confinement. It is most likely that all the slack has been taken/

taken up by having to provide domiciliary nursing care to the increasing number of early-discharge patients and women discharged before the tenth day.

Apart from the shift of work away from delivery care to postnatal nursing, domiciliary midwives are taking part in experimental schemes whereby domiciliary midwives deliver their patients in hospital as members of obstetric teams, and some are being attached to group practices so as to share the workload.

The trend towards 100% institutional confinement has also resulted in the hospital taking responsibility for the mother's antenatal and postnatal care (although, as pointed out, the load is so great that general practitioners are increasingly requested to provide routine examinations). Domiciliary midwives are, therefore, losing much of the traditional midwifery work, and having to devote much more of their specialist skill to preparing women for early-discharge from hospital and providing post-discharge nursing.

Local Health Authorities also provide ambulance services, home helps in cases where the expectant mother has no one to help her cope at home, and health visitors who continue maternity care after/

after the tenth day of the puerperium<sup>(\*)</sup>.

+ + + + +

The tripartite organizational structure of the health services has been severely criticised for many years, and the provision of maternity services has provided much of the material. As early as 1956 the Guillebaud Committee, reporting on the costs of the National Health Service, stated that: 'Many of our witnesses have told us that the division of the health services into three branches has had its most serious impact on the maternity and child-welfare services'; and they conclude: 'Our evidence does, however, indicate that the maternity services are in a state of some confusion, which must impair their usefulness, and which should not be allowed to continue . . . It seems to us that the time has now come for an appropriate body to review the whole/

(\*) : The Cranbrook Committee recommended that midwives should provide nursing care for the first ten-days post-delivery and then, if all was satisfactory, to hand over to the health visitor. The Peel Report found that some mothers discharged from hospital between 6-10 days after delivery received their first visit from a health visitor if a midwife was not available. Provided that channels of communication were well organised, such flexibility was desirable.



whole of this field to find out precisely what services - medical and educational - are needed for mothers and young children and how they can best be provided through the framework of the National Health Service.' Ministry of Health, 1956. Cmmd. 9663. Paragraphs 631 - 637.

These comments prompted the setting up of the Cranbrook Committee which reported that they had received evidence which 'did not suggest that the maternity services were in a serious state of confusion: neither would we be inclined to say that the tripartite structure of the health services has of itself proved more detrimental to the efficiency of the maternity services than to that of the other branches of the health services.' Ministry of Health, 1959. Paragraph 107. The real problem was one of co-operation and co-ordination between the individuals providing the various maternity services. 'We believe that what is required at present is the retention of the existing tripartite structure of the maternity services but with a clear definition of the responsibilities of the respective bodies providing the different parts of the service and the development - which should then become easier to achieve - of co-ordination and co-operation between them.' Op. cit. paragraph 137.

Diagram 1. illustrates the organizational structure of the maternity/

DIAGRAM 1

Possible patterns of care that a mother might receive after she has visited her general practitioner to confirm pregnancy.

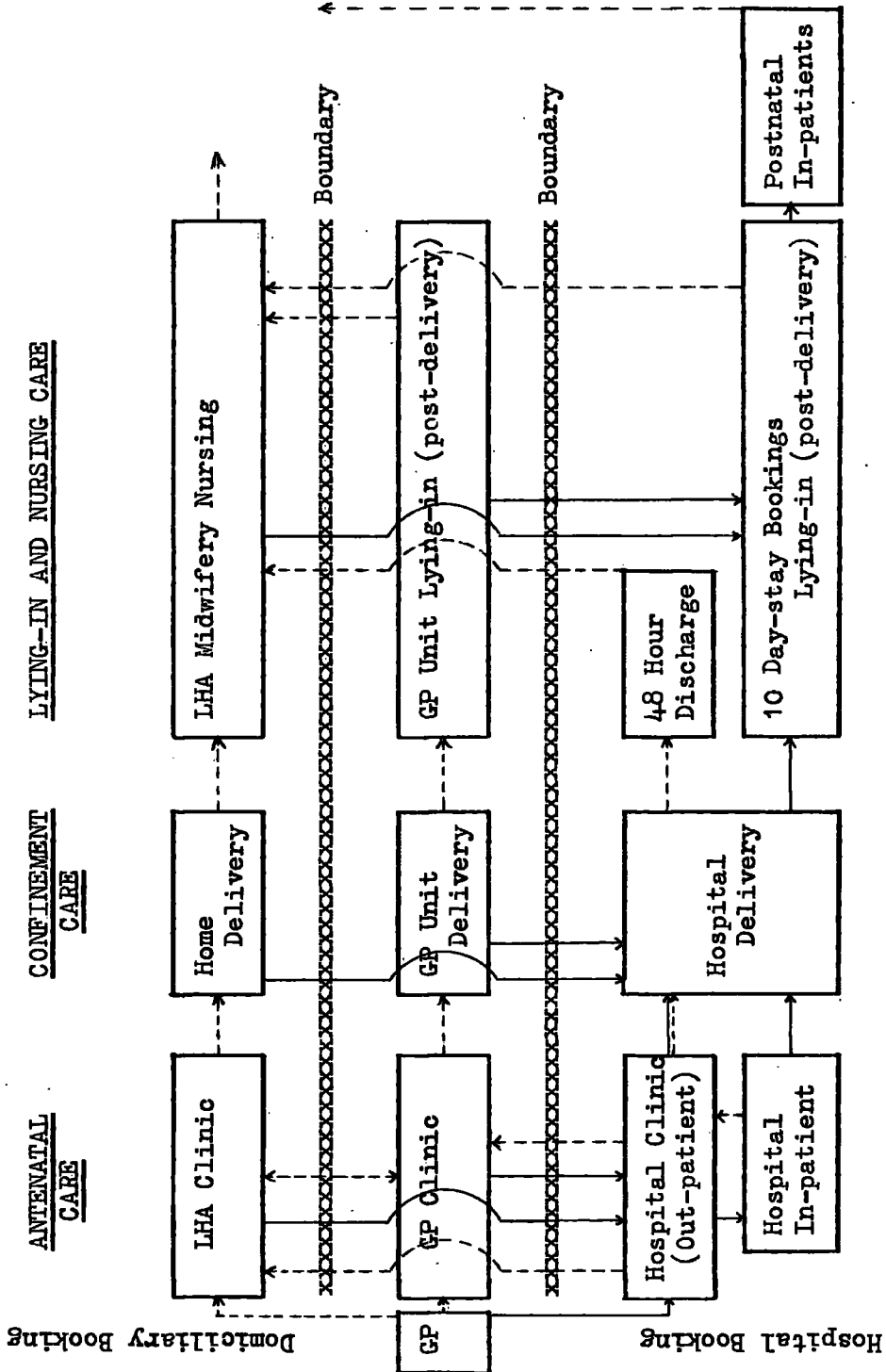

xxxxxxx : Boundaries of the three administrative authorities.

————— : High-risk assessment cases.

- - - - - : Low-risk assessment cases.

maternity services provided to expectant mothers, and shows the possible patterns of care that a mother might receive after she has visited her general practitioner to confirm her pregnancy. All movements across the authority boundaries imply possible lack of continuity of adequate care, in spite of the general practitioner's role to maintain co-ordination and co-operation between each authority and the mother. 'High-risk assessment' movements crossing both boundaries are the most dangerous, but all boundary crossings increase the risk to mother and child. (A mother attending the Local Health Authority antenatal clinic or the hospital antenatal clinic may also visit her general practitioner for additional antenatal care).

Co-ordination between the respective administrative authorities has been encouraged through the use of co-operation cards to ensure continuity of care throughout pregnancy, and the use of local representative committees of all three authorities. Painting the background to their Report, the Peel Committee comment: 'These measures (the Cranbrook proposals) have been implemented with varying degrees of success. Existing arrangements for the exchange of information are cumbersome and time-consuming, and in practice it has been found impossible to reach agreement on the use of a standard co-operation card. The value of maternity liaison committees is said to be often hampered by lack of executive function . . . Many of the strictures of the/

the Guillebaud Report on the overlapping of maternity services are still relevant. One of the main difficulties from the point of view of the patient's safety is in the transfer of records and communication generally between her different advisers.'

Department of Health and Social Security, 1970, paragraphs 30, 35/.

Having received evidence from Medical Officers of Health, Chairmen of Local Medical Committees, Senior Administrative Medical Officers and the Central Midwives Board, the Peel Committee concluded that: 'The evidence we have received suggests that a stage has now been reached when integration should begin to replace co-ordination . . .

'In our view continuity of care calls for efficient sharing of information between those providing maternity care. The fewer concerned in any individual patient's care the more efficiently communications can be made. Communications are not facilitated by the present organizational division of the midwifery profession into hospital and domiciliary midwives.' [Paragraph 244/.

'We therefore conclude that one of the first steps towards national provision of maternity care should be the unification of the midwifery service under a single/

single authority . . .' [Paragraph 245].

'An increase in midwifery staff was envisaged by Senior Administrative Medical Officers as a consequence of any increase in hospital confinements, but this was in the context of a divided service. It is to be hoped that a move towards the unification of midwifery might lead to a more rational deployment of midwives . . .'

[Paragraph 256].

The economic model developed in Chapter 4 will investigate the potential advantages of such a rationalization of the midwifery work force for Sunderland County Borough.

## THE PROVISION OF MATERNITY SERVICES IN

### SUNDERLAND COUNTY BOROUGH

In 1966 the population of Sunderland County Borough stood at 187,650 persons, having fallen from a peak of 190,580 in 1962, and of these 187,650, 29700 were married women between the ages of 15-49. In April 1967 Sunderland County Borough was extended to include Sunderland Rural District, resulting in a 1968 total population of 219,710 persons. The map shows the main urban area and the significant increase in the rural area/

SUNDERLAND-PRE + POST 1967

PRE 1967

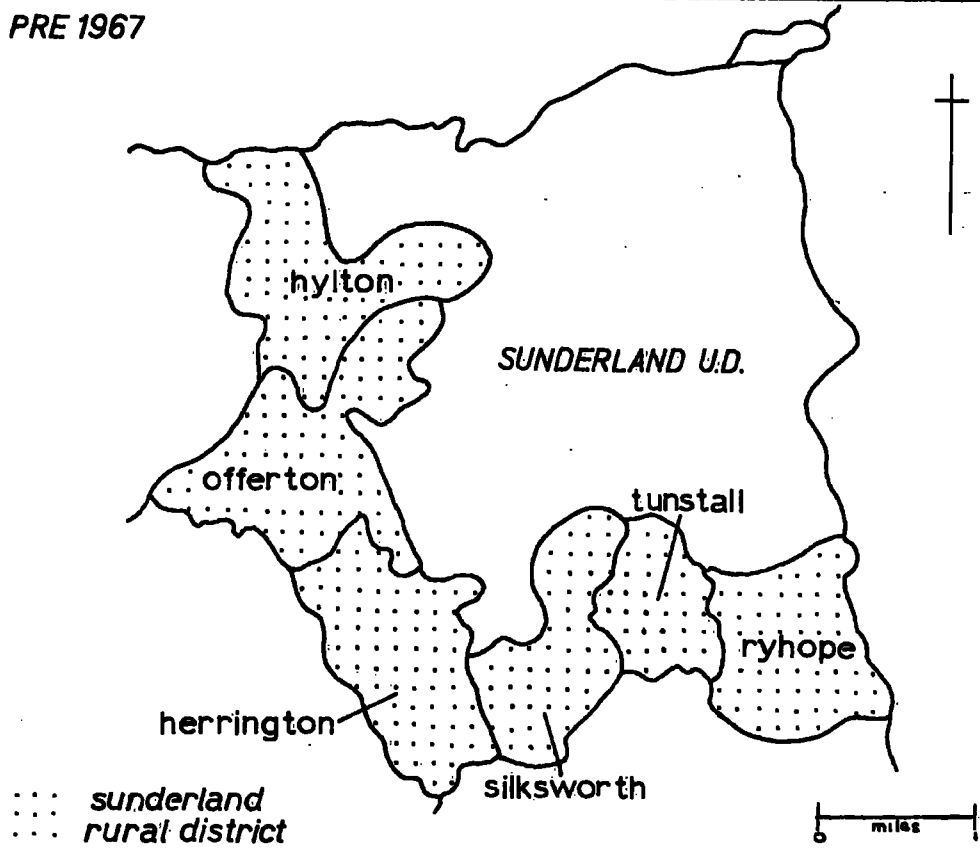

POST 1967

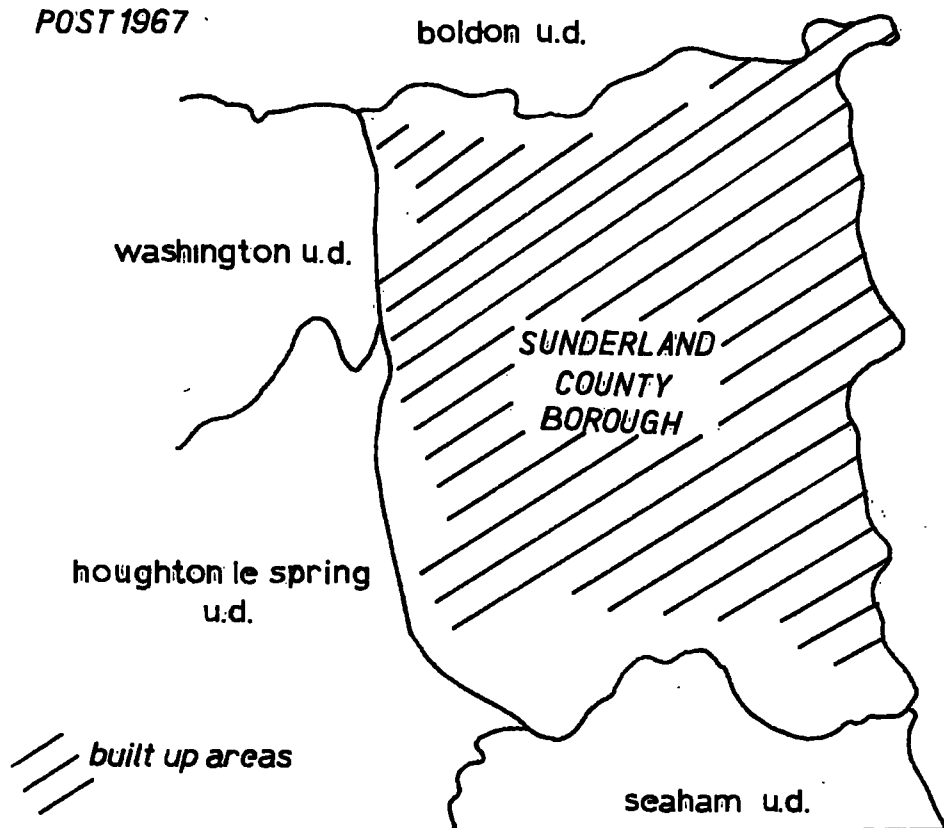

area now served by the Local Health Authority, and illustrates the need for a well organised and specialist domiciliary midwifery service. Whilst advocating a policy of 100% hospital confinement, the Peel Report recognised that ' . . . the trend towards centralisation in district general hospitals may for some time require modification to meet local needs as far as maternity services are concerned. Home confinements in rural areas will continue to present special problems and for the time being midwives serving these areas will need to be situated locally . . .' [Department of Health and Social Security, 1970, paragraph 252].

Apart from the problem of serving the rural population, Table 1 and the accompanying graph shows that the providers of Sunderland County Borough's maternity services have had to plan for a birth-rate which, although falling fairly consistently over the past ten years, has been constantly higher than the national birth rate. Finally, seasonal fluctuations in birth rate cause periods of pressure on the maternity services, and planners must take account of these (see graph 2, facing page 27).

The pattern of maternity care provision in Sunderland County Borough appears to follow standard national practice with the majority of mothers attending their family doctor for confirmation of pregnancy, and then being referred either to Sunderland Maternity/

Maternity Hospital or a Local Health Authority midwife, depending on the doctor's evaluation of the mother's risk. Some expectant mothers booked directly with a Local Health Authority midwife or Local Health Authority booking clinic, and a few normal cases were referred to the hospital by the Local Health Authority.

Routine antenatal care for hospital-booked cases varies from total care provided by the hospital clinic to general practitioner care with only abnormal cases being referred to the consultant. No Local Health Authority case attended the hospital clinic as a routine attender.

There is no general practitioner unit in Sunderland to enable expectant mothers to be delivered under hospital conditions by their own doctors (although there are plans for providing one), so most of the general practitioners' obstetric work is devoted to providing antenatal and postnatal care to patients booked with either Sunderland Maternity Hospital or the Local Health Authority, and to attending domiciliary confinements with the Local Health Authority midwife. As a general practitioner was present at only 123 out of 1330 (9.2%) home confinements in 1968, and as data on their antenatal and postnatal work was not available, the subsequent analysis of Sunderland's maternity services is largely devoted to the part played by the hospital and the Local Health Authority.



Two maternity hospitals are administered by the Sunderland Hospital Management Committee, but one of these (Thorpe Maternity Hospital) lies outside the boundaries of Sunderland County Borough, and is ignored in the subsequent analysis. Sunderland Maternity Hospital, which also serves part of Durham County Council, was in the process of being expanded at the time this study was conducted, and as a result the data suffers from some irregularities.

In 1968, Sunderland Maternity Hospital was equipped with 104 consultant-staffed beds, four delivery rooms and one theatre, and has been operating an early-discharge scheme (48 hours stay) since 1967. Relying on Local Health Authority data, of the 3,885 total live and stillbirths recorded within Sunderland County Borough, 2,555 (66%) were delivered in hospital, and 428 (17%) of these were early-discharge cases (\*). Close contact is maintained between the/

(\*) : The data on early-discharge cases is complicated by the fact that the Sunderland Maternity Hospital covers an area greater than Sunderland County Borough. Hospital records suggest that 351 cases (12.5%) of confinements were discharged within 2 days. On the other hand, Local Health Authority records resulted in a figure close on 17%, and Local Health Authority administrators intuitively believed that the figure was as high as 25%. (Both of these figures are substantially above the national figure of 14%). It is possible that some of the difference can be accounted for by those early-discharge cases which remained in hospital longer than the 2 day period used in this analysis.

the Sunderland Maternity Hospital and the Local Health Authority's Superintendent of Midwives so as to achieve continuity of care after discharge from hospital, and special Hospital Discharge Forms for both early-discharge and other hospital discharges are utilised.

Antenatal clinics are held four times a week, and defaulters are followed up, first with 2-3 reminder cards, and then the Local Health Authority Superintendent of Midwives is informed, and a domiciliary midwife visits the defaulter at her home.

As the proportion of hospital confinements has increased, so too have the number of hospital antenatal attenders. In 1966, there were 1,992 new bookings and 11,270 return visits. By 1968 these had risen to 2,679 new bookings and 15,590 return visits, and clinic sessions are now so full that it is difficult to see how more new patients can be accommodated with the present number of clinic sessions per week. If the trend towards hospital confinement and associated antenatal care is to continue, then either additional clinic time and staff must be created, or new patterns of providing care established. The economic model developed in Chapter 4 will be used to investigate some possible solutions.

A postnatal clinic, a baby-clinic and a blood-clinic are also held once a week. There is also a special baby unit of 32 cots staffed independently from the remainder of the hospital, and/

and they have not been included in this analysis.

Finally, the hospital provides an emergency flying squad staffed by a consultant or senior registrar and supporting staff which provides specialist facilities at home emergencies. This was required on 13 occasions at confinements attended by Sunderland Local Health Authority midwives. The importance of retaining such units for rural areas was stressed by the Peel Report: ' . . . Unforeseen need for hospitalisation or immediate consultant attention in such cases must be met, and some review of the existing emergency obstetric services may be needed.'

/Department of Health and Social Security, 1970, paragraph 252/.

Sunderland Local Health Authority employed 34 full-time and 3 part-time midwives in 1968, and they were responsible for the provision of domiciliary antenatal and postnatal clinics, and the domiciliary attendance of mothers booked for confinement at home.

The routine of the initial antenatal visit is that the mother is 'booked in', thoroughly examined and fully advised. An antenatal record card is completed together with an obstetric exchange card, a requirement slip and an antenatal leaflet. She is then requested to attend monthly until she is 28 weeks pregnant, then fortnightly until 36 weeks, and in the last four weeks a weekly visit is necessary. Women who fail to turn up for an appointment at the antenatal clinic are followed up by home visiting/

visiting by the midwife supervising her care. Two visits are also made to the patient's home - one to vet the home conditions and arrange the delivery room, the second towards the end of the pregnancy to see that the necessary equipment is ready.

Additional visits are made 'according to the merits of the case'. Table 2 (Page 27) gives the number of antenatal visits and attendances that midwives made at Local Health Authority clinics and patients' homes, and shows that the 1968 figures are considerably lower than previous years. Although the figures only cover four years observation, it is worth noting that they seem to suggest that as less confinement care is required of midwives, the more home visits they conduct, and it may be that the 'merits of the case' vary according to midwives' workload rather than the patients' condition.

A midwife was present at all of the 1,330 deliveries actually taking place at home<sup>(\*)</sup>, and provided ten days of post-delivery/

(\*) : A further 67 were booked for home delivery, but were transferred to hospital because of complications. It would seem that these would be worth special study to discover whether they had been 'diagnosed' high-risk cases; and if so, whether they had refused hospital delivery.

post-delivery (puerperium) nursing care<sup>(\*)</sup>. They also made 6,285 nursing visits to the 1,056 cases discharged from hospital before the tenth day. Table 2 gives the trend for domiciliary visits to hospital discharged cases, and shows that, in spite of an overall drop in the total number of discharges and visits, the average number of visits per discharge has increased. This change is probably due to the reduction in the average length of stay at the Sunderland Maternity Hospital, and also the implementation of the early-discharge scheme in 1967 - both of which will have required extra visits from domiciliary midwives.

Finally, the Local Health Authority provides classes on 'Preparation for Childbirth', but attendance at these dropped dramatically from a peak of 1,349 attendances in 1967 to 711 in 1968. It is difficult to determine the exact reason for this sudden drop, but it may be a consequence of the combined effects of a fall in the total number of pregnancies and the increasing responsibility of the hospital in providing antenatal care.

The overall picture is, therefore, in line with the developments in the pattern of maternity service provision described by the Peel Report. Although there has been an overall reduction/

(\*) : The policy is to make two visits for the first three days of the puerperium, and then one visit per day for a week.

reduction in total pregnancies, the proportion of work conducted by the Sunderland Maternity Hospital is increasing relative to the domiciliary antenatal and confinement services, but there is a consequent increase in the demand for postnatal domiciliary care of cases 'unknown' to the midwife. On the assumption that the trend towards hospital confinement will continue, the unification of the midwifery service would seem to be the only solution to the triple dilemma of staffing Sunderland Maternity Hospital, of domiciliary midwives' discontent at losing the centrepiece of their art, and of decreasing continuity of patient care. It is appreciated that such a change in policy is beset with many social and organisational problems which are, however, outside the scope of this study.

TABLE 1

YEAR	ENGLAND AND WALES (I)			SUNDERLAND COUNTY BOROUGH		
	TOTAL BIRTHS (TH)	BIRTH RATE	INSTITUTIONAL CONFINEMENT RATE	TOTAL BIRTHS (TH)	BIRTH RATE	INSTITUTIONAL CONFINEMENT RATE
1959	764.4	16.5	64.2	3.870	20.3	4.7
1960	800.8	17.2	64.7	3.967	20.6	4.5
1961	827.0	17.6	65.6	3.969	20.5	5.0
1962	854.0	18.0	65.9	3.920	20.2	5.1
1963	869.0	18.2	68.2	3.863	19.9	5.5
1964	890.5	18.5	70.0	3.760	19.4	5.1
1965	876.6	18.1	72.5	3.543	18.4	5.6
1966	863.1	17.7	75.0	3.583	18.7	5.4
(*) 1967	844.7	17.2	77.8	3.994	18.5	5.6
1968	831.1	16.9	80.6	3.885	17.4	6.6

(\*) : In April 1967, Sunderland County Borough was extended to include Sunderland Rural District.

(I) : Report of Chief Medical Officer of Health 'On the State of the Public Health for 1968', Department of Health and Social Security, 1969a.

TABLE 2

DOMICILIARY MIDWIFERY IN SUNDERLAND COUNTY BOROUGH

	1965	1966	1967 <sup>(*)</sup>	1968
(1) Total number of antenatal visits at clinic	12863	14270	14454	11234
(2) Total number of antenatal visits at home	6349	5915	6542	5849
(3) Total number of cases attended	1647	1727	1939	1397
(4) Clinic visits per case <sup>(I)</sup>	7.8	8.3	7.4	8.0
(5) Home visits per case	3.7	3.4	3.4	4.2
(6) Number of visits to cases discharged from hospital	6921	6478	6516	6285
(7) Number of cases discharged from hospital	1937	1603	1597	1056
(8) Number of visits per case discharged from hospital	3.6	4.0	4.1	6.0

(\*) : In April 1967, Sunderland County Borough was extended to include Sunderland Rural District.

(I) : Row 4 includes cases booked for domiciliary confinement but transferred to hospital at, or during, delivery.



CHAPTER 2

ASSESSING THE QUALITY OF MATERNITY SERVICES

The problem of quality assessment has been a continued source of frustration to all concerned with health service research. Certain economic and statistical implications of quality control are discussed in the Appendix in connection with the derivation of the 'technical coefficients' used in later chapters, but this section is concerned with determining the qualitative relationship between the services required by expectant mothers, and the supply of antenatal, confinement, and postnatal care provided by general practitioners, hospitals and Local Health Authorities.

Mortality rates have often been used to indicate national and regional variations in quality, but unless they are accompanied by detailed investigation into service-usage rates (determining which mothers are not receiving the care that doctors consider that their medical and social condition merits), mortality rates can have little explanatory or predictive value. Even when high mortality rates have been linked with certain 'high-risk' or 'low service-user' mothers, the problem of why these mothers are not receiving proper care has to be examined. Only then can constructive efforts be made at providing a high quality/

quality service.

Two mortality rates are customarily used as indices of the increasing quality of maternity care:

(a) The Maternal Mortality Rate<sup>(\*)</sup> for England and Wales has decreased from 54 deaths per 100,000 births in 1952 to 22 in 1963 and 20 in 1966. [Report of Confidential Enquiries into Maternal Deaths in England and Wales, 1964-66, Department of Health and Social Security, 1969b]. Of Sunderland's expectant mothers, no women died in pregnancy or childbirth in 1967, and only one (out of 3,885 live and still-birth) in 1968. These figures are far too small for any significant comparisons to be made between Sunderland County Borough and England and Wales, so we will turn our attention to the second mortality index.

(b) The Perinatal Mortality Rate<sup>(I)</sup> for England and Wales has fallen steadily from 35.0 deaths per 1,000 total live and still-birth in 1958 to 25.4 in 1967. (Table and Graph 1, Page 63). Although the Sunderland County Borough figures fluctuate quite widely each year, some idea of the trend can be derived from the/

(\*) : Maternal deaths (excluding abortion) per 100,000 total births.

(I) : Still-births and deaths less than one week old per 1,000 total live and still-births.

the two-yearly moving averages showing that the perinatal mortality rate for Sunderland County Borough has been consistently above the national rate, although since 1965 the gap has been narrowed quite considerably.

Breaking the perinatal mortality rate into its component parts of stillbirth<sup>(\*)</sup> and neonatal<sup>(I)</sup> mortality rates again shows that the Sunderland rates have been consistently higher than the national rates, although the 1968 neonatal mortality figure for Sunderland suggests that the regional variation has finally been overcome, possibly by improved post-delivery care for 'high-risk' babies.

In spite of the good co-operation between the Sunderland Maternity Hospital and Local Health Authority in following up defaulters from antenatal care, the gap between the national and Sunderland stillbirth mortality rate suggests that there may be an important group of mothers who are failing to take advantage of the care being offered.

A break-down of mortality rates for the U.K., Sweden, France, Netherland, and U.S.A. is given in Table 2, Page 64. International comparisons are complicated by different methods of/

(\*) : Stillbirths per 1,000 total live and stillbirths.

(I) : Deaths less than one week old per 1,000 total live and stillbirths.

of data collection and recording, but the figures suggest that the standard of postnatal care in the U.K. is very high, whilst pre-natal and delivery rates could be improved. Whether this is a factor determined, in part, by the quality of antenatal care requires detailed investigation, but the perinatal mortality rate might be significantly reduced if mothers were provided with antenatal care earlier than the 16th week, thereby enabling low-birth weight to be detected and corrected. [Robertson and Carr, 1970; who rely heavily on the work of Evers in Holland and Brindlecombe et als in the U.K.]<sup>7</sup>.

Finally, the fact that the perinatal mortality rate for the whole of the northern region is higher than the national perinatal mortality rate indicates that the generally lower standard of living in the north may play an important part in keeping the Sunderland perinatal mortality rate above the national perinatal mortality rate. Ashley has suggested that the perinatal mortality rate is significantly higher in areas (including Durham) where hard coal is mined, whilst there was no significant association with industrialisation per se. He offers some possible explanations for this, and amongst them:

- (1) Poor social and nutritional conditions during childhood and adolescence of the mother.
- (2) Geological factors, like coal-dust.

He concludes with an appeal for further detailed investigation into environmental factors. [Ashley, 1968].

Apart from these very general observations, mortality rates per se can do little to inform the health service researcher, and it is not surprising that studies of the quality of maternity care have concentrated on certain factors believed to be responsible for maternal and perinatal mortality. Maternal deaths have been the subject of special triennial reports, and now that the perinatal mortality rate has fallen to 25.4 deaths per 1,000 live and stillbirths in England and Wales, it has been suggested that each Local Health Authority (or similar local area) could prepare similar detailed enquiries into individual deaths. [Shegog, 1966]. However, the volume of research on factors relating to perinatal mortality has grown enormously over the past ten years, and the remainder of this chapter employs the findings of these to help determine some possible factors behind Sunderland County Borough's high perinatal mortality rate. The approach adopted has been:-

- (a) To identify those groups of expectant mothers who are potential 'high-risk' cases.
- (b) To evaluate whether they are receiving the care most suitable to their 'high-risk' condition.
- (c)/

- (c) To examine the reasons why some of these do not receive this 'most suitable' care.

A. Confinement Care

(a) In 1959, the Cranbrook Report recommended a 70% institutional confinement rate, which they believed to be 'adequate to provide for the following patients:

- (1) Those in whom there is an abnormality or in whom an abnormality might be anticipated (this would include mothers with four or more children and all those over 35 years).
- (2) Those who require admission on social grounds (including social emergencies).
- (3) All primigravidae<sup>(\*)</sup> not included in the above groups.
- (4) Those patients booked for home confinement who require emergency admission for confinement for medical reasons.' /Ministry of Health, 1959; paragraph 70/.

That this was a fairly reliable guide for advocating hospital delivery/

(\*) : Women having their first baby. Synonymous with nulliparae and parity 0.

delivery was born out by the findings of the 1958 British Perinatal Mortality Survey [Butler and Bonham, 1963]. They found that:

- (i) 'The mortality<sup>(\*)</sup> for mothers having their first babies is some 6% greater than the national average . . . Mothers having their fourth baby have an increased risk of 12% above average, while for mothers with four or more previous babies the increased risk amounted to 54%'. [Op. cit. Table 2, page 16]. A regional examination also showed that the north had the second highest proportion of women having their fifth or subsequent baby, and that their risk was 73% above the national average.
- (ii) With the exception of women aged between 20-29 having their first or second baby, mortality-risk steadily rises with increasing age, particularly above the age of 30. Of those aged 30 years or more, only those in the age group 30-34 having their second baby had a mortality rate below the national average. The mortality of women having their first baby rises from the national average for 25-29 year olds to 32% above for 30-34 year olds, 68% above for 35-39, and 113% above for 40-44. All mothers over the age of 35 whatever their parity, have/

(\*) : Perinatal mortality - not maternal.

have mortality rates above the national average.

Butler and Bonham conclude: 'Clearly there is no case for any mother in such high risk groups to be confined without the benefit of full specialist facilities'.  $\angle\bar{O}$ p. cit: Table 5, page 227.

(iii) Family social class (as measured by the five standard social classes of the Registrar General) was an important factor in the mortality rate, being 31% below the national average for Class I families, and rising progressively to 28% above the national average for Class V. (For unmarried mothers the mortality rate was 40% above).  $\angle\bar{O}$ p. cit: Table 4, page 217. Again, it is interesting that the northern region was third to the north west and scottish regions in having the highest proportion of Class V families within the population, and had a mortality rate 41% above the total national average for this class.

(iv) Expectant mothers with poor obstetric histories, and mothers expecting a multiple pregnancy, also constitute 'high-risk' cases.  $\angle\bar{O}$ p. cit: Tables 8-11, pages 32-397.

(v) Finally, the duration of gestation, the birth-weight and other medical factors (e.g. breech presentation) play important (probably the most important) part in determining/



determining mortality. Op. cit.: Sections F and G.

See also Law (1967); Ashford, et al (1968, 1970)7.

The first four of these have been the traditional 'high-risk' categories of mothers readily identifiable at their first antenatal visit, and they have, therefore, figured most prominently in service-usage studies. However, as these factors are themselves highly correlated, it is worth considering an attempt to ascertain their adjusted effects through the use of multivariate analysis. Using the data from the 1958 Perinatal Mortality Survey, Feldstein and Butler showed that, by deriving estimates of perinatal mortality rates that would be expected to prevail if the factors that had been 'adjusted out' had no effect, the adjusted para 4+ mother has a risk of only 24% above the average (compared with a crude rate of 54%). Similarly women under 20 have a perinatal mortality rate of 12% below average, compared with being 7% above in Butler and Bonham's analysis. On the other hand, the crude deviation for primigravidae<sup>(\*)</sup> (6% above the national average) is shown to underestimate the risk of having a first child, the age-social class adjusted value is 15%. Feldstein and Butler, 19657.

More/

(\*) : Feldstein (and other authors) sometimes use the term primiparae for women having their first child. As the proper definition of primiparae is 'women who have had one pregnancy', I have preferred to use 'primigravidae' throughout the text.

More recently, two studies have recommended that all primigravidae should be booked for confinement in specialist units. [Hobbs and Acheson, 1966; Hudson, 1968].

A second attempt to go deeper into the 1958 perinatal mortality rate survey results was conducted by Law who carried out a two year survey on the Breech Presentations, Multiple Pregnancies, Elderly Primigravidae and Grand Multiparae in the north west metropolitan region in 1962-64. His detailed findings are rather beyond the scope of the economist, but 'the report recommended that all cases in the four high-risk groups should be delivered in hospital, with the possible exception of certain selected grand multiparae'. [Department of Health and Social Security, 1970; paragraph 87].

Finally, in a comparative survey of the perinatal mortality rates for Aberdeen and Newcastle, Russell showed that the higher Newcastle perinatal mortality rate was due to 'the poor reproductive performance of a particular section of the community. In the upper three social classes there is very little difference between the two cities; but in social classes IV and V the perinatal mortality rate among grand multiparas is much higher in Newcastle'. [Russell, et al, 1963]. As Sunderland has a high proportion of grand multiparas, it may be that Russell's findings are relevant, and at least worth investigation./

investigation.

(b) Having identified certain groups of women who may be categorised as 'high-risk' cases, we turn to investigate whether they received the specialist care that their conditions merited.

The national picture has improved over the years as the proportion of women confined in hospital has increased from 70.0% in 1964 to 77.8% in 1967; and the parity/age structure has changed as well. In 1964, 35% of legitimate births were parity 0, whilst in 1967 this had increased to 40%. Births of women having their 2nd-4th baby dropped from 56% to 53% total births, and from 9% to 7% for parity 4+. Births to women < 25 year olds increased by 7%, and decreased by 17% for ≥ 35 year olds.

Table 3, page 65, shows that the proportion of parity 4+ women receiving delivery care at home has decreased, and that there has been a similar fall in most para 0 mothers receiving domiciliary confinement care. The most disturbing feature is the increase in the proportion from 2.6% to 4.9% of elderly primigravidae receiving confinement care at home. As the earlier section of this chapter pointed out, elderly primigravidae are high-risk mothers who are readily identifiable early in pregnancy (unless they fail to confirm pregnancy or to seek/

seek antenatal care), who require specialist care. This would seem to be significant evidence of a decrease in the quality of maternity service provision. Moreover, various regional studies have confirmed the hypothesis that these and other 'high-risk' mothers are failing to receive specialist confinement care.

A study of the use of maternity services in Glasgow revealed that, although the hospital confinement rate had risen from 71% to 85% between 1963-67, '6% primigravidae and 24% of mothers having their fourth or subsequent child were not delivered in hospital. Similarly, a history of previous still-birth or high maternal age (35 years and over) did not raise the chances of hospital delivery and adverse social conditions contributed only slightly to the chances of hospital delivery'. Further investigation revealed that selection for place of delivery showed little improvement in the five years studied, and that, in 1967, selection for home confinement was very poor. [Richards, et al., 1970].

The institutional confinement rate for the area served by Sunderland Local Health Authority has risen from 46.7% in 1959 to 65.8% in 1968 but unfortunately detailed analysis of the use of Sunderland's maternity services in 1968 was not possible. However, it was possible to use material provided by Dr. J. S. Robertson<sup>(\*)</sup> in order to investigate a randomly selected sample for 1967. As the/

(\*) : Medical Officer of Health, Barton-upon-Humber.

the sample had an institutional confinement booking-rate of 58% compared with Sunderland's actual rate of 55% in 1967, it is felt that the data is fairly reliable.

Robertson and Carr showed that 31.5% of Sunderland County Borough's mothers were having their first baby (compared with the national figure of 40%) [Robertson and Carr, 1970], and further examination of the weekly returns revealed that approximately 20% of these high-risk mothers were booking for domiciliary delivery. Sunderland County Borough also has a large proportion of parity 4+ women (15% compared with the national figure of 7%), and of these, approximately 48% also booked for domiciliary delivery. Of these 48%, approximately 27% were aged 35+. (Again, double the national figure). No doubt many of these domiciliary booked mothers were delivered in hospital, but the fact that about 150 high-risk mothers out of a total of 900 (17%) first booked for domiciliary delivery is not encouraging (in terms of the national policy).

In recommending that all primigravidae should be booked for and delivered in hospital, Hudson pointed to the high rate of transfer of primigravidae both before and during labour which indicated that they should all be booked for confinement in specialist units. The Peel Report drew special attention to the increased risk of mortality when patients were transferred from home/

home to hospital as shown by the Perinatal Mortality Survey of 1958: 'The perinatal mortality rate for (these) infants of mothers booked for home confinement but transferred to consultant units in late pregnancy or during labour was shown to be three times the national survey average'. [Department of Health and Social Security, 1970, paragraph 27]. In Sunderland County Borough in 1968, 67 cases had to be transferred from home to hospital during delivery (4.8% of total home bookings). No details were available on how many babies from these pregnancies died, nor of the risk-condition of the mother at the time of her booking. It would seem that such information would be well worth collecting. Certainly, from purely maternal and infant safety reasons, it would seem undesirable to transfer so many to hospital during labour. But why do these high-risk cases fail to receive specialist care?

(c) The assertion by Feldstein that supply is an important factor in determining demand [Feldstein, 1967, especially chapter 7] and that hospital proximity has an important influence on maternity admission [Chapter 8], is born out by Hobbs and Acheson's study of the use made of consultant beds within the Oxford Record Linkage area in 1962. They found that (a) the presence of a local general practitioner maternity unit greatly reduced the proportion of mothers booked for consultant care in each/

each risk group<sup>(\*)</sup>, and (b) that when a general practitioner unit was accessible to practices, increasing distance from a consultant unit further depressed the proportion of mothers in each risk group booked for consultant care. Where no general practitioner unit was accessible to practices, increasing distance from a consultant unit did not reduce the proportion of consultant bookings. Comparison of perinatal mortality showed that practices with access to a general practitioner unit were considerably higher (28 per 1,000) than those without such access (19 per 1,000), and there was no evidence to suggest that the higher mortality was due to an inherently less favourable population from the obstetric point of view.

An editorial in the British Medical Journal commented that 'a heavy responsibility lies on all her (the high-risk mother) advisers . . . before deciding on the best place of delivery', [British Medical Journal, 1966, page 494], but as Hobbs and Acheson point out, 'it is difficult to be certain to what extent this failure reflects the attitude of the mother or the attitude/

(\*) : Defined as (1) High-risk : mothers older than 35;

primigravidae older than 30. Multiparae with 4 or more children, and mothers with a previous still-birth.

(2) Intermediate-risk : all primigravidae not in 1.

(3) Low-risk : all other mothers.

attitude of the general practitioner to the relative merits of consultant and general practitioner care. This merits further study'. [Hobbs and Acheson, 1966, page 504].

A fairly detailed study of the selection procedures of a south-coast city with a population of a quarter of a million found that general practitioners accept 'high-risk' maternity patients for domiciliary confinement not because they are convinced of the superiority of childbirth at home (as seems true of the district midwives), but because they fail to persuade these women to accept a hospital confinement. It concludes that 'women who asked for a home confinement even if they were in one of the high-risk categories seemed to be given little persuasion to change their minds', and proposes the offering of early discharge from hospital to mothers who dislike the long absence from home that a traditional hospital booking implies. [Topliss, 1970].

The Glasgow study also investigated the attitudes of general practitioners and found that whilst many general practitioners said that the decision on the place of confinement was always their own, some said that the choice was always left to the patient. Although the investigation made it clear that the general practitioner was the key figure in selecting the place of confinement and that a high proportion of mothers would accept his decision, less than 40% of the doctors stated that, in/



in their practices, first and high-parity births were among the most common indication for hospital delivery. 'There would seem:', they write, 'to be a great need for a periodic restatement of the high-risk categories . . . It is clear that the Domiciliary Midwifery Service is undertaking - and is expected by general practitioners to undertake - much 'high-risk' maternity work . . . Patients for home confinement need to be selected with far greater care than at present. Clearly this is very largely the responsibility of the general practitioner.' [Richards, et al, 1970. See also Vaughan, 1968].

Both these studies have made it plain that many of the women who do not wish to go to hospital for confinement are precisely those whose social or medical condition merits it. Although not significant at the 5% level, Topliss found that a higher proportion of Class I and II mothers preferred hospital delivery to Class III, IV and V mothers, and that nearly two-thirds (60.5%) of the women preferring a home confinement chose it because it did not mean separation from the family, particularly from other children. Similarly, in a study of 3,474 'normal' deliveries in the Oxford Record Linkage Study Area in 1962, Feldstein showed that women in higher social classes obtain admission to hospitals (and especially teaching hospitals) more frequently than average. 'These findings', he writes, 'suggest that the patient's attitude and ability to use the/

the system, as reflected by social class, are more important determinants of hospitalisation than her home conditions. If this pattern is widespread, it may indicate a serious inefficiency in the allocation of health service resources'.  
[Feldstein, 1967].

In Glasgow, of the 41 women eventually delivered at home, 13 disliked hospitals and 10 desired to be at home with the other children. Moreover, of these 41, 27 cases were considered to have grounds for hospital confinement, and 16 of the 27 were having their fourth or subsequent pregnancy.

Finally, domiciliary midwives play an important role in determining the place of delivery. Topliss found that district midwives were clearly convinced that home confinement was superior to hospital in important ways and had minimal disadvantages - which seems to explain their readiness to accept bookings from mothers in 'high-risk' categories.

Material again made available by Dr. J. S. Robertson throws some light on Sunderland Local Health Authority midwives' attitudes to patient selection for hospital confinement (in 1967).

In answer to the question: 'If due to excessive demands, or to local circumstances you can discriminate, which of the following do you routinely reject or try to divert to Hospital?

1. Grand Multiparae

2./

2. Women who have had a previous still-birth
3. Women who have had a previous post-partum haemorrhage
4. Women who have had previous complications
5. Women who are living in insanitary conditions
6. Elderly primigravidae
7. Primigravidae

Of the forty-one completed forms, sixteen (39%) tried to persuade all seven categories to book for hospital, and a further seventeen (41%) tried to persuade all but primigravidae. In all, twenty-two (54%) midwives did not refuse, nor tried to dissuade primigravidae from booking for home delivery. Recalling the recent arguments for confining primigravidae to hospital and the large number of women transferred from home to hospital during labour it may be that a change in midwifery policy towards primigravidae might increase the quality of Sunderland's maternity services. From the forty-one replies it is also reasonable to conclude that, ignoring the general practitioners' attitude towards hospital confinement, the chances of a particular 'high-risk' mother being persuaded to seek specialist obstetric care will vary according to the midwife with whom she books.

These, then, are some of the factors and attitudes which have been shown to have some influence on the selection of 'high-risk' mothers for specialist care. However, as Vaughan has pointed out, 'in many of the circumstances leading to perinatal death, good antenatal/

antenatal care is as important as hospital delivery'. Indeed, he continues, 'hospital booking may produce a situation in which the mother feels that she cannot face up to the visit and delays her first attendance . . .' [Vaughan, 1968].

B. Antenatal Care

The provision of comprehensive antenatal care to expectant mothers has, for many years, been considered an important factor in the safe delivery of a mother and her baby, and maternal mortality and perinatal mortality rates are, to some extent, a reflection of the quality of that care.

'The importance of early prenatal (antenatal) care cannot be over-emphasised. Only by an adequate examination, including a pelvic examination, by the sixteenth week of pregnancy, can the size of the uterus be accurately related to the period of amenorrhoea. After eighteen weeks it is no longer possible to relate the duration of amenorrhoea to uterine size accurately to within two to four weeks. When, later on, induction of labour, elective caesarean section or dysmaturity of the baby (a baby small in size for the duration of pregnancy), are being considered, precise information on the relation of the duration of amenorrhoea to the size of the uterus in the early weeks is imperative . . . Good prenatal care requires early and frequent visits by the patient and the careful recording by the clinician of a series of simple/

simple observations.' [Butler and Bonham, 1963, pages 62, 70].

In spite of the health service's intention to provide comprehensive antenatal care to every mother who attends for examination, there are still some women being confined who have received no antenatal care, some who have attended very irregularly, and others who do not attend before the sixteenth week. These mothers and their babies are liable to be at considerable risk - in the 1958 Perinatal Mortality Survey, Butler and Bonham found that the perinatal mortality rate for babies whose mothers had received no antenatal care at all was five times the average; the rate among babies born to women who had received only some antenatal examination was four times, and among women who had three or four antenatal examinations it was three times that for all babies born during the week. [Op. cit: Table 16, page 61]. Moreover, less than half the mothers in the survey began antenatal care before the sixteenth week - high parity women being the worst attenders, only 29.3% presenting themselves for examination at the sixteenth week.

Since 1963 there has been considerable interest and research into the obstetric and social factors behind these 'maternity drop-outs' to determine the possible causes for their lack of demand.

Re-investigation of Butler and Bonham's survey has shown that, while 60% of social class I mothers attended for antenatal examination before the seventeenth week of pregnancy, only 50% of class/

class III, and 39% of class V mothers came before this week. Working from the other end of the attendance time-scale, this same re-examination found that whilst only 4.1% social class I mothers attended after the twenty-eighth week, this increased to 6.4% for class III, and to 11.3% for class V mothers. These figures suggest that 'women of low socio-economic status contribute the highest proportion of underutilizers'. (J. B. McKinlay, (1970a)7).

In a subsequent analysis of all legitimate births in Aberdeen for three, two-year periods, McKinlay shows that the percentage of parity 3+ women demanding antenatal care before the seventeenth week rose substantially over the years for all classes, except social class I.

Although his research 'suggests that the problem of providing early antenatal care to this known high-risk group (class V) may not be as intractable as was previously thought', it does show that class V mothers still make the least use of antenatal services (in Aberdeen). Bearing in mind Russell's comparative study of Aberdeen and Newcastle (see page 37), it is probable that Newcastle's class V mothers make even less use of antenatal services.

Secondly, McKinlay found that a large percentage of young primigravidae were failing to make adequate use of antenatal services. Whilst there has been a fall in the percentage of parity/

parity 3+ women attending after the twenty-eighth week, and a corresponding increase in the percentage of these similar categorized women attending for their first antenatal visit before the seventeenth week, there has been a disturbing decrease from 44.1% to 31.2% in the number of primigravidae attending before the seventeenth week. Similarly, the young mother with one child also appears to underutilise the available resources.

McKinlay concludes that, 'while the overall maternity care position of multiparae, especially in the older age groups, has improved considerably, social class V still remains the worst group in this respect. Moreover, in the recently emerged trend toward underutilization by primiparae<sup>(\*)</sup>, low socio-economic status again appears to be an important factor within the present system. This phenomenon would seem to have organizational implications for the delivery of adequate maternity care to different sub-groups within the community. (McKinlay, 1969).'  
[McKinlay, 1970a].

(c) McKinlay's study isolates quite satisfactorily certain groups of mothers who fail to make early use of antenatal facilities, but there is little analysis of why these particular groups/

(\*) : McKinlay uses the term 'primiparae' in the proper sense.

groups should seek care so late, if at all. Apart from the hypothesis that 'the stigma associated with prenuptial conception may be a major factor contributing to the underutilization of antenatal services by young primigravidae' and the 'a priori' assumption that women of low socio-economic status are less able/motivated to seek early antenatal care than women of higher status, there is no explanation for the lack of demand. [But see: McKinlay, 1970b].

A study investigating the incidence of antenatal care underutilization and which attempted to provide some explanation was conducted by Robertson and Carr on eleven Local Health Authorities, one of which was Sunderland. They found that those areas which had experienced consistently high perinatal mortality rates yielded higher proportions of late bookers than those with low perinatal mortality rates.

Out of 10,236 obstetric bookings, 164 (1.6%) were found to have had no antenatal care before the end of the thirty-second week of gestation, and these were subsequently interviewed so as to ascertain something of their social backgrounds and attitudes.

Of these 164 late bookers, as many as 67 (41%) were in 'irregular marital situations' (\*), and the majority of them were young/

(\*) : Widowed or divorced; married but pregnant to men other than their husbands; conception before marriage; single but cohabiting; single and not cohabiting.



young and nulliparous. Few of these women were pleased about their pregnancy and its concealment was by far the most important reason for not seeking antenatal care earlier in pregnancy. Over a third either had very unstable finances or had not yet assumed housekeeping responsibilities. Nearly a quarter of their households had no wage earners at all, and another 15% relied on women's earnings only.

Of the remaining 97 (59%) late bookers in 'normal marital situations', 96% already had families, and 37% were parity 4+. 41 (42% of 97) were wives of skilled manual workers, and 35 (36%) of unskilled. For about two-thirds the net weekly household income per head after deducting rent and other regular commitments was under £3. 5. 0, and only a few supplemented their housekeeping money by going out to work. One-third of the households were rated by the interviewers as having severe or very severe problems, frequently requiring skilled social casework. A surprisingly large number of these married women were displeased about their pregnancy (30%), and only 13% planned it. 15% (of 97 normal late bookers) were pregnant as a result of contraceptive failure, and a further 5% had religious objections to contraception. But in the great majority of cases (60%) no contraceptive measures were taken at all.

There was no single predominant cause (save concealment in the case of irregular marital conditions) determining delay in seeking/

seeking antenatal care. Robertson and Carr found that 30% of 'regular' condition mothers continually failed to appreciate the need for antenatal care . . . 'They were predominantly people of poor educational attainment, of low socio-economic status, living in relatively overcrowded circumstances and many of them had required help and supervision by social casework agencies'. [Robertson and Carr, 1970]. Change in area of residence (22%), difficulties regarding the care of existing children (12%), the cost or inconvenience of attending surgery or clinic (6%) and failure to recognise pregnancy (7%) were the most frequent causes of delayed booking among the married. (It is interesting that 9% of 'irregular condition' women did not suspect pregnancy).

Of special interest to the study of Sunderland County Borough's maternity services were Robertson and Carr's findings that of the eleven Local Health Authorities they investigated, Sunderland had the largest incidence of parity 4+ women, and yet the percentage of women attending after the thirty-first week is as low as 3.1%. The record for attending before the twelfth and sixteenth weeks is also good compared with the parity distribution and perinatal mortality rate. Detailed analysis of Sunderland County Borough was impossible with such small numbers involved - only 44 cases of late-booking and two perinatal deaths. However, Sunderland's figures seem to suggest that the high perinatal mortality rate is more/

more likely to be correlated with the poor reproductive abilities of multiparae and other high-risk groups rather than late-booking per se. Whilst early and continual antenatal care is obviously desirable and is an important factor in reducing mortality rates, it is possible that mortality is high for late-bookers, not so much because they booked late, but because they were intrinsically high-risk cases. In this connection, it is interesting that 7 (16%) of Sunderland's late-bookers were nulliparae, and a further 11 (25%) were parity 4+.

These hypotheses are confirmed by the study of all births in Glasgow in 1967. This showed that the overall perinatal mortality rate was little influenced by the stage at which antenatal examination was first sought (except for the small number of women attending at or later than the 40th week). Richards, et al., confirm the findings of the other two studies that young women and women aged 40+ tended to begin antenatal care later than women of other ages, and also that increasing parity is associated with a decline in the proportion first attending before the tenth week, and an increase in the proportion attending first at 20-29 weeks and 30-39 weeks. Similarly primigravidae and parity 4+ women tended to delay seeking antenatal care until the 30-39 weeks, and 11.1% of all illegitimate pregnancies did not begin antenatal care until after the 30th week, compared with only 1.1% legitimate.

From a sample of 500 deliveries, 393 were traced and interviewed  
by/

by Richards, et al., and were considered representative of the total birth population in the city. Of these 393, all but two received some antenatal care, but one-third did not re-attend for antenatal examinations after confirmation of pregnancy. If this is representative of the whole country then there is a grave underutilization of antenatal services seen in the light of Butler and Bonham's warnings. However, any analysis of frequency of visits is complicated by premature labours and extra visits for the incipiently abnormal case. 'Antenatal care (in Glasgow) was sought by 53.7% during the first trimester; 13 (3.3%) delayed until some time in the last trimester. One was a primipara and six were having a fourth or subsequent baby (one was having her eleventh). All were in social classes III-V, including three whose husbands were unemployed at the time of the birth (one in class III and two in class V). All had left school before the age of sixteen and none had received any further education or training. Some had married before the age of twenty (one at sixteen)'.  
/Richards, et al., 1970/. Reasons given for not attending for early antenatal care were: fear, prejudice and ignorance of hospital, Local Health Authority and/or general practitioner clinics; and the mother in her eleventh pregnancy did not attend because the hospital clinic was far away and she could not leave the children.

Mother's/

Mother's preferences for one type of antenatal care (i.e. for general practitioner, hospital or Local Health Authority clinic) to another were contradictory and showed no clear or consistent pattern by age, parity or social-class distribution.

C. Conclusions

Drawing the findings of these various studies into some sort of future policy for Sunderland County Borough, the primary concern seems to be, as with the whole of the country, for the unification of the midwifery services. Apart from enabling communication to flow more easily and for staff to be more efficiently allocated, such a move would stress that domiciliary confinement is a complement to, rather than a competitive substitute for, hospital confinement.

Recent obstetric research has shown that certain groups of women are at greater risk than others, and that these should receive specialist care. Whilst resources are limited not all mothers have been able to enjoy such care, and it is also recognised that not all women want to go into hospital. Indeed, it is often the high-risk case that is most unwilling to seek specialist care, or who, for family or ability reasons is least capable of availing herself of specialist care. This is especially true of Sunderland County Borough which still retains much of its community character with relatives close at hand, and/

and a tradition of domiciliary delivery. If these 'high-risk and low-motivated' women are to receive specialist care, then hospital confinement must be made as attractive as possible, and general practitioners and midwives given every incentive to encourage such cases to seek specialist care.

Unification of the midwifery service would enable mothers who were previously afraid of the 'unknown' hospital to receive care from the same midwife (or small group of midwives) throughout pregnancy, delivery and puerperium, thereby allaying many fears. With the influx of hospital-based 'domiciliary' midwives, the hospital staff would be less overworked, and 'domiciliary' midwives would retain their specialist skills so that, however much higher the hospital confinement rate rose, rural populations and women preferring home delivery would not suffer.

Secondly, hospital delivery can be made more attractive to the mother by the use of general practitioner units - although there are disadvantages compared with normal hospital delivery. (Hobbs and Acheson, 1966; Feldstein, 1967; Royal College of Obstetricians and Gynaecologists, 1968).

A general practitioner unit has not been provided for Sunderland County Borough practitioners, but there are tentative plans for building one. Such units, closely attached to specialist/

specialist wards, have been shown to have the advantages of specialist hospital facilities and expertise whilst retaining continuity of care and maintaining general practitioners' and domiciliary midwives' morale. (Slugett and Walker, 1956; Oldershaw and Brudenall, 1968; Rhodes, 1968; Rawlings, 1969, 1970). All these authors agreed that there were problems in the administration and running of such units, and yet each suggests that they are of considerable benefit to patients. Patients themselves were fairly enthusiastic - Rawlings found that of 200 mothers delivered at a general practitioner unit between November 1967 to April 1968, 144 (72%) would have chosen domiciliary delivery if the unit had not existed. Furthermore, 192 (96%) were enthusiastic for the scheme, and 193 would use it again. Amongst the reasons given, the reassurance of the specialist resources close at hand, and continuity of care, were most often mentioned.

Such a unit working in close co-operation with Sunderland Maternity Hospital might encourage high-risk mothers to leave the security of their homes, and act as an incentive to general practitioners and 'domiciliary' midwives to encourage these cases to come into hospital.

Thirdly, early-discharge schemes have enabled beds to be used more efficiently, and has therefore helped to increase the proportion/

proportion of women receiving specialist care. This policy of keeping a woman in hospital for only forty-eight hours was initially intended to be a short term measure until more maternity beds were provided, but recently it has received support as a permanent pattern of care. (Pinker and Fraser, 1964; Craig and Muirhead, 1967; Atherton and Bamford, 1967; Russell and Miller, 1970). Such a scheme has been described as 'an efficient and economical way of providing the safety of hospital delivery for the maximum number of mothers and babies,' (Department of Health and Social Security, 1970, paragraph 111), and Russell and Miller conclude that 'most (Local Health Authority midwives) agreed readily that planned early-discharge is increasingly popular with mothers and is now securely established as part of the contemporary pattern of maternity care'.

Sunderland Maternity Hospital introduced a planned early-discharge scheme in 1967 and this has been maintained through close links with the Local Health Authority. Unfortunately, data relating to the numbers of women receiving early-discharge care was complicated by the fact that the Sunderland Maternity Hospital serves an area larger than Sunderland County Borough, but it does appear that there is room for increased use of forty-eight hour discharge in order to make hospital confinements more attractive to mothers who normally opt for home/



home delivery. Provided that general practitioners and midwives are aware of the advantages, then reluctant mothers might be more easily persuaded. The major disadvantage of early-discharge at present is a direct result of the tripartite structure and division of midwifery. Both create moments of crisis in continuity of care and communication, and neither hospital nor domiciliary midwives have fully approved of the change in the pattern of their workload that early-discharge schemes have necessitated. It is suggested, however, that a unified midwifery service would enable the workload to be restored to a more traditional pattern, and patient care to be a continuous process based on midwife groups.

Finally, it has been suggested that further increases in the hospital confinement rate will not result in a significant fall in the perinatal mortality rate, and that the proportion of domiciliary deliveries should be encouraged to increase on condition that earlier and more comprehensive antenatal care is provided. [Robertson, 1970]. The argument for this is based on the Dutch system which relies on a very high domiciliary confinement rate and efficient antenatal service, and achieves a very low perinatal mortality rate. (See Table 2, Page 64. Comparative figures for 'Late Foetal Deaths' and 'Deaths less than one day old' suggest that the antenatal/

antenatal care provided in the United Kingdom might be improved). Whilst not suggesting that the Dutch pattern of maternity care would be suitable for the United Kingdom, the neonatal and stillbirth rates do suggest that the overall perinatal mortality rate might be reduced more significantly by an increase in the quantity and quality of antenatal care than by pushing the hospital confinement rate towards one hundred per cent. As if to confirm this, the consultant paediatrician at the Sunderland Maternity Hospital remarked that future improvements in perinatal mortality must come from a reduction in the stillbirth rather than the neonatal mortality rate, and that this would be achieved through increasing the standard of antenatal care.

If, however, this extra antenatal care is to be provided by the hospital out-patient clinic, then there will have to be an increase in the total amount of clinic and staff resources. In 1968 the hospital antenatal out-patient clinic was working beyond full capacity - some mothers were leaving the clinic unexamined having waited/

waited long after their appointment time<sup>(\*)</sup>.

(\*) : An appointment system was implemented but failed to alleviate the overcrowding problems as mothers still preferred to come on a 'first-come-first-served' basis, so that the clinic was full the moment it opened.

TABLE 1

	PERINATAL MORTALITY RATE		STILLBIRTH MORTALITY RATE		NEONATAL MORTALITY RATE	
	ENGLAND and WALES	SUNDERLAND	ENGLAND and WALES	SUNDERLAND	ENGLAND and WALES	SUNDERLAND
1958	35.0	38.0	21.5	23.5	13.5	14.5
1959	34.1	34.6	20.8	21.7	13.3	12.9
1960	32.8	36.5	19.7	22.2	13.1	14.4
1961	32.0	31.0	19.0	20.1	13.0	10.8
1962	30.8	35.7	18.1	18.6	12.7	17.1
1963	29.3	34.9	17.2	18.6	12.1	16.3
1964	28.2	35.6	16.3	21.0	11.8	14.6
1965	26.9	37.2	15.8	21.4	11.1	15.8
1966	26.3	31.8	15.3	19.5	10.9	12.3
1967	25.4	33.8	14.8	19.5	10.6	13.5
1968	24.7	26.8	14.5	16.7	10.2	10.0

TABLE 2

<u>Late Foetal Deaths (*) per 1,000 Live Births</u>					
	U.K.	SWEDEN	NETHERLANDS	FRANCE	U.S.A.
1962	18.4	12.6	14.8	16.4	12.4
1963	17.6	12.1	14.5	16.3	12.2
1964	16.6	11.3	13.6	15.8	12.8
1965	16.0	10.3	13.3	15.4	12.6
1966	15.6	10.0	13.1	15.2	12.2
1967	15.1	9.5	12.2	14.9	-
<u>Deaths &lt; 1 Day Old</u>					
1962	7.4	5.3	4.2	2.3 <sup>I</sup>	10.4
1963	7.2	5.0	4.9	2.1 <sup>I</sup>	10.4
1964	7.1	4.5	4.6	2.1 <sup>I</sup>	10.2
1965	6.6	4.5	4.7	2.0 <sup>I</sup>	10.2
1966	6.5	4.0	4.3	-	9.9
<u>Deaths &gt; 1 &lt; 6 Days Old</u>					
1962	5.6	5.8	5.8	7.6 <sup>‡</sup>	6.1
1963	5.1	6.0	5.5	7.5 <sup>‡</sup>	6.0
1964	4.9	6.0	5.5	7.2 <sup>‡</sup>	5.9
1965	4.7	5.1	5.4	6.9 <sup>‡</sup>	5.7
1966	4.6	4.9	5.3	-	5.6

(\*) : Pregnancies of at least 28 weeks duration.

Source : Demographic Year Book, 1968. UN (1969).

I : Understated.

‡ : Overstated.

TABLE 3

Age Group	Total Births		Legitimate Births								Illegitimate Births	
	Legitimate and Illegitimate		Parity				4+				Hospital Home	
	%	%	0	1 - 3	4+	Hospital	Home	Hospital	Home	Hospital	Home	
1964	70.0	30.0	87.4	57.5	42.5	69.1	30.9	82.4	17.6	82.4	17.6	
1967	77.8	22.2	90.2	66.1	33.9	82.4	17.6	88.0	12.0	88.0	12.0	
1964	74.1	25.9	85.8	55.4	44.6	61.0	39.0	85.0	15.0	85.0	15.0	
1967	80.5	19.5	89.8	63.3	36.7	77.9	22.1	89.9	10.1	89.9	10.1	
1964	65.3	34.7	89.4	55.8	44.2	65.5	34.5	77.3	22.7	77.3	22.7	
1967	73.5	26.5	90.7	65.0	35.0	79.8	20.2	83.2	16.8	83.2	16.8	
1964	75.6	24.4	97.4	71.5	28.5	74.5	25.5	82.5	17.5	82.5	17.5	
1967	84.5	15.5	95.1	80.7	19.3	86.0	14.0	88.6	11.4	88.6	11.4	

Source : Report of Chief Medical Officer of Health on the State of the Public Health for 1968.

[Department of Health and Social Security, 1969].

CHAPTER 3

PLANNING THE SUPPLY OF MATERNITY SERVICES

Chapters 1 and 2 described the provision of maternity services under the National Health Service to expectant mothers, and analysed some of the factors influencing demand. This and the following chapter investigate the problem of planning the supply of maternity services during the short and medium time period when all, or many, of the resource levels are fixed.

The model proposed is not a substitute for long-term planning (when all resource levels are variable), which is based largely on evaluation of the needs of the community and the allocation of resources to meet these needs as cheaply as possible. In spite of the unreliability of forecasting trends in population, patterns of disease, and preventive and curative techniques, long-term planning is a vital part of the administrator's job and decisions involving capital expenditure must be made. However, the health service administrator is also responsible for short and medium term planning which is no less important and just as difficult. He is severely limited in his actions by decisions taken in the past, and by the present levels of available resources - many of which cannot be changed significantly on a year-to-year basis. Increasing the total number of beds available to a population is

a/

a long-term decision requiring the building of new hospital units; the training of more doctors to staff these units takes over five years for even the most junior grade, and the total available budget is unlikely to allow any significant increases in other staff and equipment during the next few years. This means that even for periods of up to five years, resource levels are fixed, and that any change in policy must be effected by the reallocation of existing resources rather than the employment of new ones. To a large extent, therefore, planning is dependent upon the flexibility (substitutability) of the available resources between outputs<sup>(\*)</sup>. Most important of all, it is dependent upon the planners' evaluations of the relative benefits of the activities provided to the population.

Confronted with a populace increasingly aware of deficiencies in health service provision, and with the continual clamour from specialists of every department for more buildings, beds, staff and equipment so as to be able to meet the increasing demand, the administrator must be provided with information which will enable him to plan future levels of provision efficiently - from both the technical and economic aspects.

The model that is developed here first describes the 'observed'/

(\*) : In future, the operational researcher's term 'activities' will be used in place of outputs or services.



'observed' technology relating the available resources to the activities actually provided, and this is assumed to be efficient for the particular time-period concerned. [/If the administrator, having studied the technology matrix, considers that it is incorrectly measured or if he makes changes in the actual technology, the model can be quickly and cheaply adjusted/]. Once the technology has been described (in linear terms), an adaptation of linear-programming techniques enables doctors' implicit evaluations of the relative benefits of the activities provided to be made explicit, and the effects of various types of planning decisions to be predicted.

The great advantage of this approach is that it takes the observed production technology, and uses the current activity levels to make explicit the trade-offs implicit in the decisions already taken by policy-makers. These can then be presented to the administrator for checking and then as information for future policy decisions - at no stage do the economists' own value judgments enter the analysis. If the policy-maker accepts the technology and trade-offs as reasonable approximations to reality, the model can be used to predict the effect of changes in resource supply, changes in the technology and changes in doctors' preferences.

Before applying this technique to Sunderland's maternity services, a simplified example is used to illustrate the various ideas/

ideas involved.

+ + + + +

Consider the hypothetical case of a maternity service providing only two types of care for expectant mothers of a particular community. A hospital provides 'early-discharge' and 'normal-stay' care, and this is the only choice there is. The hospital is equipped with eight beds (equivalent to 3,200 bed-days per year), and is staffed by two doctors working 4,800 hours per year, and five midwives working 10,000 hours per year.

It is known that, on average, each 'early-discharge' case requires two bed-days, six doctor-hours, and ten midwife-hours of the total available resources. Similarly, each 'normal-stay' case requires eight bed-days, four doctor-hours, and twenty midwife-hours. (These figures are not in the least supposed to represent current practice in a real hospital).

This information is enough to determine the hospitals' technology, and to ensure technical efficiency. Table 1 summarizes this information, and Figure 1, Page 83, represents the technically feasible levels of output, as defined by the technology and the total quantities of the available resources. Any point on or within the boundary OABDE is technically feasible, and any point on ABDE is technically efficient. Any point to the left and below ABDE (e.g. F) is/

is technically inefficient as more of both types of care can be provided without any change in the technology or in the total amount of available resources. A point to the right and above ABDE (e.g. G) is impossible given the present technology and resource availability. It will be observed, however, that only a shortage of midwives prevents point G from being technically feasible.

Without any knowledge of patients' preferences or of doctors' evaluation of the benefits from the two activities, the maternity hospital would be providing care efficiently if the level of care corresponded to any point on ABDE. Suppose, however, that the hospital is operating in a situation of perfect competition, and that patients are willing to pay up to, but no more than, £11 for 'early-discharge' care and £14 for 'normal-stay' care - in other words, these prices represent the patients' evaluations of the benefit that they will derive from the two kinds of care - then the hospital is in a position to plan supply of the two types of care so that the blend of output maximises total consumer benefit. The prices that mothers have put on the two types of care reveal that an additional 'normal-stay' case is  $\frac{14}{11}$  (1.27) times more beneficial than an additional 'early-discharge' case. Diagrammatically, this benefit function (more generally referred to as the 'objective' function) is represented by any line with the slope  $-\frac{14}{11}$  (-1.27), and the maximum blend of output is achieved by moving this line away from the origin until it is tangential to ABDE. At this point, total benefit/

benefit will be at a maximum. From Figure 1 it can be observed that maximum benefit is achieved when output is at point B where care is provided to 150 'normal-stay' cases and 700 'early-discharge' cases. It will be seen that at this blend of output, the total quantity of both doctor-hours and midwife-hours are used up, whilst some bed-days are lying idle. (\*)

Now, suppose that patients' preferences change so that they are willing to pay up to £33 for 'normal-stay' care, but still no more than £11 for 'early-discharge' care. Such a change in preferences alters the slope of the benefit function from -1.27 to -3.00 ( $-\frac{33}{11}$ ). If the hospital's administrators are aware of this change, they will reallocate their available resources in such a way that the blend of output maximises the new benefit function. If the blend of output continued to be point B, then total benefit would be £12 650, whereas if the blend was where the new benefit function was tangential to ABDE, point D, then total benefit would be/

(\*) : This simple model does not take account of the fact that the demand for confinement care is limited by the total number of pregnancies actually taking place during the specified time period. In the following chapter on Sunderland's maternity services a demand constraint is added to the technology matrix which states that the total number of pregnancies predicted by the model must be equal to the number of pregnancies actually taking place.

be at a maximum (14 300). At this blend of output, bed-days and midwife-hours constrain further provision, whilst doctor-hours are slack.

The purpose of this simple example has been to show that the planning of an economically efficient supply of maternity services in the short-run is dependant upon the prior knowledge of three sets of information:

- (a) The technology of the production process.
- (b) The total quantities of the available resources.
- (c) The consumers' preferences as regards the services provided.

The first two sets of data are available (to some extent) from routine hospital statistics, and the relationship between the resources employed and the services provided are assumed to be linear. The problem lies in determining the weights on the benefit function. The removal of the health service from the imperfect market mechanism, whilst achieving free access to those in need rather than to those with the ability-to-pay, resulted in the removal of the price system. There are no prices to signal consumer preferences, and no objective information on doctors' or patients' preferences. How, therefore, can planners be provided with this information?

### Inverse Programming

Chapters 1 and 2 emphasised the complex relationships between the factors affecting demand and patient need. Although there are some notable exceptions, it is reasonable to assume that the major factor affecting the demand for maternity services is the doctor's evaluation of his patient's need for a particular type of care, an evaluation based on his assessment of the expectant mother's medical and social condition. Thus he will recommend a pattern of care which will, in his medical opinion, minimise morbidity and mortality risks to both mother and child. The doctor's prime responsibility is to the patient that he is examining at that particular moment. It may be assumed, therefore, that if 'normal-stay' care is recommended in preference to 'early-discharge' care, it is because the doctor considers that 'normal-stay' care will minimise the mother's and baby's risks.

A policy to recommend the type of care most appropriate to the mother's medical and social condition is practical in the long-run when there is no scarcity of resources to limit the supply of either type of care. However, in the short and medium time periods when all or some resources are fixed and the supply of both types of care is limited by the technology and total quantity of available resources, the doctor must consider not only the mother in his care at that particular moment, but also the possibility that a mother in greater medical need will be the next case to present. In other words, the doctor's evaluation of the benefits from/

from the two types of care is a complicated intuitive judgment based on his assessment of the individual's and the community's risk. Decisions are made by a complex interaction between doctors, patients, administrators and committees. Inverse programming enables the resulting implicit evaluations to be made explicit by deducing relative weights from the technology of the production process, the total quantities of the available resources, and the actual blend of output during a particular time period.

Returning to the hypothetical hospital, the production possibilities are the same as those shown by Table 1, and the range of technically efficient points are again illustrated by the frontier ABDE in Figure 1. Verification of technical efficiency is achieved, in theory, by checking that the hospital is not producing a blend of output below ABDE. In practice, however, the method of deriving the technical coefficients relating resources to outputs is likely to result in 'automatic' technical efficiency.<sup>(\*)</sup> (See the detailed account of the derivation on the Sunderland County Borough's technology matrix; Appendix).

When consumer preferences were known, economic efficiency was/

(\*) : A check on the correctness of the model's specification can be made through discussions with the hospital's doctors and administrators.

was achieved by providing (initially) at point B, where the slopes of the limiting resources were  $(-\frac{4}{6}) = -0.66$  for doctor-hours, and  $(-\frac{20}{10}) = -2.00$  for midwife-hours. As soon as the ratio of consumer preferences changed from 1.27 to 3.00 it was observed that the point of optimum production moved to point D, where the slopes of the limiting resources were, midwife-hours at -2.00 and (instead of doctor-hours) bed-days at  $(-\frac{8}{2}) = -4.00$ ; and it can be shown that the optimum point of production would have switched from point B to point D as soon as the consumer-preference ratio exceeded 2.00. (If the ratio had been exactly 2.00 then there would be a set of optimum points of production defined by the line joining points B and D, the midwife-hour constraint line). Similarly, if the ratio had fallen below 0.66 the optimum point of production would have shifted to point A. There is, therefore, a range of consumer-preference ratios, determined by the slopes of the limiting resource constraints, associated with every technically efficient point of production. This reasoning may be inverted: every technically efficient point of production implies a range of consumer-preference ratios (more fittingly described as 'doctor-evaluation' ratios), determined by the slopes of the limiting resource constraints.

Over a specified time period the hospital is observed to produce at point B on the technically efficient production frontier ABDE, where 150 'normal-stay' cases and 700 'early-discharge' cases are/



are provided with care. At this production point it has already been determined that the slopes of the two limiting resource constraints are  $-0.66$  and  $-2.00$ . From these two values it may be inferred that doctors are implicitly valuing the benefit from an additional 'normal-stay' case to be within the range  $0.66$  to  $2.00$  times the benefit from an additional 'early-discharge' case. Similarly, if the hospital was observed to be producing at point D, the slopes of the limiting resource constraints imply that doctors consider an additional 'normal-stay' case to be from  $2.00$  to  $4.00$  times as beneficial as an additional 'early-discharge' case. (In this simple example the ranges on the 'doctor-evaluation' ratios are large and not of much descriptive or predictive value. However, in the more elaborate models of real hospitals and health care systems, the complex technology employing many resources to provide many services can yield ranges which are considerably narrower and therefore of some descriptive and predictive value).

Inverse programming is therefore a descriptive technique which relies on the administrators' past decisions (involving the interdependence of ethical and technical factors) to obtain numerical indicators of the relative benefits that have been placed on hospital activities. Provided that the data input is correct and that the model has been correctly specified, the weights revealed by inverse-programming together with the technology data can be used to predict the outcome of various policy/

policy changes through traditional linear programming methods.

There are two methods of obtaining precise numerical values for the relative-benefit weights when the technology becomes more complicated than the two activity example. The first uses a particular type of geometric average. (Hawgood and Morley, 1969, Appendix 17). But this is not considered here.

The second uses marginal cost data and some elementary welfare economics, and is the method used as a preliminary step towards finding the weights on the objective function that would predict the actual observed levels of each activity.

The marginal cost approach relies on the assumption that there would be diminishing marginal benefit from increasing health service activities. If an activity is thought to be worth providing at its present level, and if the marginal benefit of that activity increased as the activity level was expanded, then it should be expanded at the expense of another activity which is at a level where marginal benefit is decreasing. In the unlikely event of the marginal benefit of every activity increasing as each activity was expanded, then that activity with the greatest potential increase in marginal benefit should be increased at the expense of the activity with the least potential - the argument holds in ratio terms. Assuming that a hospital (or health-service administrative body) is providing two types of care efficiently and/

and relies on prices as a summary of information relating to consumer preferences, the optimum benefit point of production will be where the blend of care provided is such that £1 worth of resources devoted to one activity could not give greater benefit if it were devoted to the other activity. This implies that the relative benefits of the activities provided can be derived from a knowledge of the marginal cost ratios.

For a time period of less than a year, the supply of resources is fairly rigidly fixed. As the time-period increases, planners are able to change the resource mix to cope with changes in the demand for the activities provided. Since the costs of these resources are known, and the matrix of technical coefficients describing the production technology provides information on the amount of each resource that is required to provide a unit of each activity, the cost of a unit of each activity is easily calculated. These medium-run average variable costs - which do not include any allocation for overheads - are assumed to be close approximations to short-run marginal costs, and constant with respect to output.

Applying this approach to the hypothetical hospital, and assuming that the cost of an hour of a doctor's time is £1, and the cost of an hour of midwife's time is 10/- (£0.50), then the cost of providing an additional 'normal-stay' case and an 'early-discharge' case can be calculated from the matrix of technical coefficients./

coefficients. (See Table 2, Page 84).

If the hospital is attempting to provide care efficiently, it will increase the quantity of 'normal-stay' care until the expenditure on providing an additional unit of this activity would yield greater total benefit if spent in providing an additional unit of 'early-discharge' care. Assuming the hospital knows that the cost of providing an additional unit of 'normal-stay' care ( $MC_n$ ) is £14, and the cost of an additional unit of 'early-discharge' care ( $MC_e$ ) is £11, then it knows that the marginal cost of 'normal-stay' care is  $\frac{14}{11} = 1.27$  times the marginal cost of 'early-discharge' care. If the administrator is allocating variable resources efficiently, he must judge that the last unit of 'normal-stay' care is 1.27 times more beneficial, to the community served, than the last unit of 'early-discharge' care.

Provided that consumers agree with the administrators' evaluation of the relative benefits of the two activities, the ratio of marginal costs equals the ratio of marginal benefits. (For possible inconsistencies, see pages 80-82). Writing  $MB_n$  and  $MB_e$  for the marginal benefits of 'normal-stay' and 'early-discharge' care respectively,

$$\frac{MC_n}{MC_e} = \frac{MB_n}{MB_e}$$

This reasoning holds for more than two activities, such that:

$MB_n/$

$$\frac{MB_n}{MC_n} = \frac{MB_e}{MC_e} = \dots = \frac{MB_z}{MC_z} = k$$

where k is some constant. Thus  $MB_n = k.MC_n$ .

In the hypothetical hospital example, the objective function was defined as:

$$\text{Maximise : } MB_n.n + MB_e.e$$

where  $MB_n$  and  $MB_e$  denote the doctor's implicit evaluations of the relative benefits of the two activities ('normal-stay' and 'early-discharge' care), and the variables n and e denote the level of each activity. This is the same as:

$$\text{Maximise : } k.MC_n.n + k.MC_e.e$$

$$\text{or : } MC_n.n + MC_e.e$$

since only the ratios are relevant.

In this way, knowledge of marginal costs enables the ratio of marginal benefits to be derived, and a preliminary set of weights to be placed on the objective function.

Apart from helping to fix the range of the 'inverse-programming' benefit ratios, estimates of marginal costs may also provide some insight into the administrators' understanding of consumer preferences.

Imagine that the hypothetical hospital is observed to provide care at point B, where it has already been established that technical efficiency is achieved. Inverse-programming puts the/

the range of the benefit ratios between 0.66 and 2.00. If the marginal cost ratios ( $\frac{14}{11} = 1.27$ ) are put on the objective function and the activity levels predicted by traditional linear-programming, point B will be chosen as the optimum blend of supply. The marginal cost ratios seem correct.

Suppose, however, that the hospital was observed to provide care at point C (also technically efficient). Inverse-programming makes the ratio exactly 2.00, but the constant marginal cost ratios will continue to predict point B as the optimum blend of supply.

There are several possible reasons for this lack of correspondence. From the inverse-programming point-of-view, the decisions may not have been optimal, or the data relating to the technology and resource availabilities might be so inaccurate that even the useful qualities of a linear model for approximations cannot compensate for such inaccuracies. (However, these should be apparent after consultations with doctors and administrators, and any inaccuracies amended).

Secondly, from the marginal cost approach of assessing relative benefits, the decision may not have been optimal, or the costing data inaccurate, particularly since the time span for the costings may not coincide with the time span for the decisions. (Again, these should emerge from discussion, and the/

the model respecified). Finally, the decision-maker of a social service may be taking account of consumer preferences, rather than relying solely on prices.

Combining the inverse-programming and the marginal cost approaches in the hope that errors will be reduced (there is no reason why they should be compounded), the following rules are made:

1. If inverse-programming describes a wide range of weights on the benefit function which would predict the same blend in the activity levels, and if the marginal cost ratios fall within this range, then choose the marginal cost ratios as the relative weights. (See Figure 2).
2. If the marginal cost ratios do not fall within the range of weights, choose that end of the range which is nearest to the marginal cost ratios. (See Figure 3).

The computer print-out provides valuable information on the sensitivity of the model, and enables the marginal costs to be plugged into the objective function as weights to see what blend of activity levels is predicted. These marginal costs are then adapted (using the print-out information) until the actual activity levels are predicted. These weights, derived from the marginal costs, are the ones which are accepted for use in the predictive planning model.

FIGURE 1

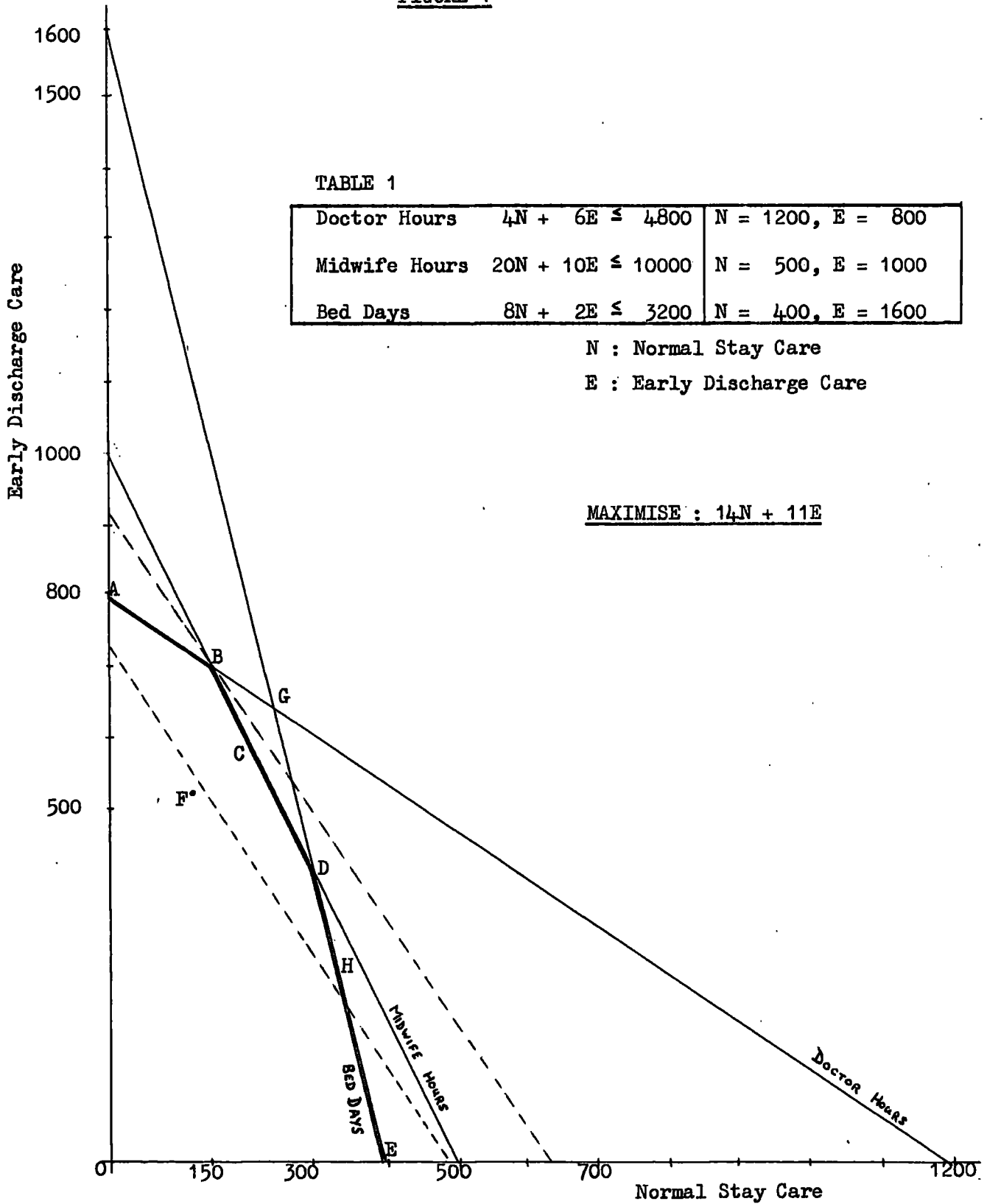



TABLE 2

Resource	Unit Cost (£)	Normal Stay	Early Discharge	Normal Stay (£)	Early Discharge (£)
Doctor Hours	1.0	4	6	4	6
Midwife Hours	0.5	20	10	10	5

MC = 14                      11

---

---

[Bed Days are not costed in this simple model].

Figure 2

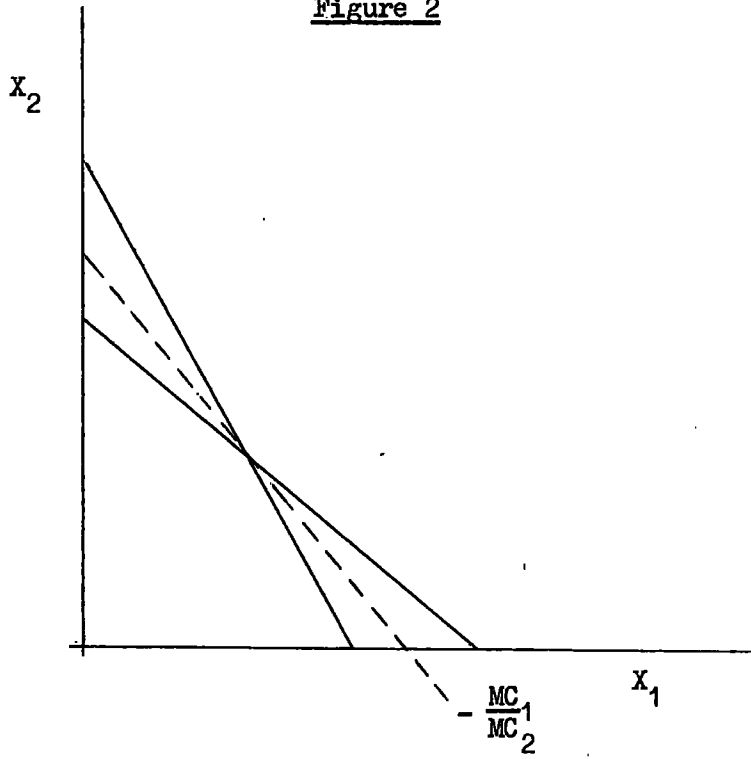
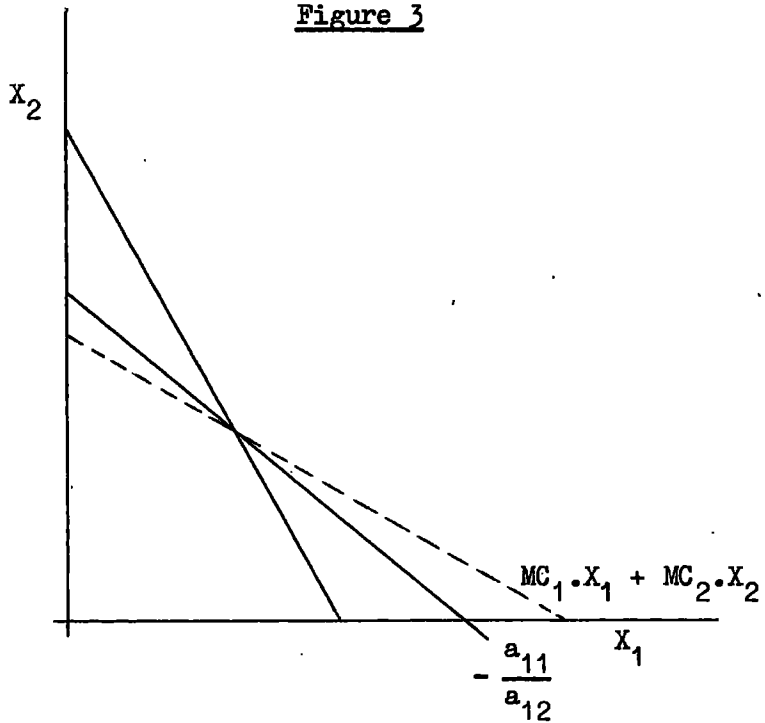

Figure 3



CHAPTER 4

Planning the Supply of Maternity Services

to Sunderland County Borough

Chapter 3 illustrated the use of programming to reveal preferences in a simple hypothetical hospital providing only two types of care. This model is now extended to the services provided to expectant mothers by Sunderland Local Health Authority and Sunderland Maternity Hospital. Chapters 1 and 2 reviewed some of the social factors involved in the provision of a 'quality efficient' maternity service, whilst the model used in this chapter seeks to analyse the 'economic efficiency' of the present blend of maternity service provision in Sunderland County Borough.

The model is first used to describe the situation in 1968. By observing the technical relationships between the total available resources and the services provided, inverse programming enables the 'benefit-ratios' implicit in doctors' decisions to be described quantitatively. These 'benefit-ratios' are then briefly compared with the short-run marginal costs in order to discover whether there are any significant differences.

Second, the model is used for predictive purposes. Having described/

described the situation, the model is used to monitor the effects of changes in doctors' preferences, resource supply, and the technology.

### The Services Provided

It is convenient for the purpose of this study to divide the supply of maternity services to Sunderland County Borough into ten mutually exclusive types of care. (\*) This is not an exhaustive catalogue of the services provided to expectant mothers, but the output levels from these ten types of care are quantifiable, and they are the services most relevant to planning the provision of maternity care. They can be summarized as follows:

DANC Domiciliary Antenatal Care refers only to the antenatal care that is provided for expectant mothers at Local Health Authority clinics. It does not include those visits/

(\*) : For the purposes of this study, only final activities are classified - intermediate activities which are not of direct benefit to expectant mothers are treated as part of the final activity. The training of midwives is an important intermediate activity, particularly as much of the training is done 'on the job'. Time and budget spent on long-term planning, personnel management and maintenance are excluded.

visits by midwives and health visitors to mothers' homes, nor does it include antenatal care provided at general practitioner surgeries. Measured by the total number of antenatal visits and attendances at clinics which was 11 234 in 1968.

HANO Hospital Antenatal Care (out-patients) refers only to antenatal care provided to expectant mothers at the Sunderland Maternity Hospital Out-Patients Clinic. Again measured by the total number of attendances which was 20 902 in 1968.

HANI1 Hospital Antenatal Care (in-patients) refers to those  
HANI2 expectant mothers who are provided with specialist in-  
HANI3 patient care during their antenatal stage of pregnancy.  
Measured by the number of cases discharged from the hospital wards. In 1968, there were 491 such cases, being

364 HANI1 with an average length of stay of 6.6  
bed-days

43 HANI2 with an average length of stay of 1.6  
bed-days

84 HANI3 with an average length of stay of 6.0  
bed-days.

DCC Domiciliary Confinement Care refers to the care which a mother receives when she is delivered at home. It also/

also includes any antenatal home visits which she may receive from the midwife or health visitor, and the nursing care provided to mother and child for the first ten days post-delivery. It does not include any subsequent care the mother or her child may receive. Measured by the total number of cases delivered at home which was 1330 in 1968.

**HEDC** Hospital Early-Discharge Care refers to mothers booked for confinement at the Sunderland Maternity Hospital and whose condition allowed them to be discharged after only 48 hours. This policy of reduced hospitalised care requires close co-operation with the Local Health Authority who provide nursing care to the mother and baby until the tenth day. Measured by the total number of cases discharged after 48 hours, which was 351 in 1968.

**HNSC** Hospital Normal-Stay Care refers to those mothers booked for a ten-day stay in hospital, although many are discharged before the ten days are completed. In 1968, 2313 mothers were discharged from hospital between the third and tenth days, with an average length of stay of 8.0 days.

**HLSC** Hospital Long-Stay Care. In 1968, 119 cases required stays in hospital of more than ten days. The range was from eleven to twenty-six days, with an average length of/

of stay of 12.3 days.

HPNI Hospital Postnatal Care (in-patients). A small number of women have to be admitted to the maternity hospital for specialist post-delivery care. In 1968, there were twenty-one mothers discharged after such care, with an average length of stay of 8.0 days.

There were sixteen resources which could be limiting the expansion of services in the short-run:

DMID Domiciliary Midwives, measured in man-hours available for the ten activities during 1968.

DCL Domiciliary Clinics, measured in clinic-hours, being the total number of hours that clinics are available.

DHW Domiciliary Health Visitors, man-hours.

DMO Domiciliary Medical Outfits, £'s.

DDD Domiciliary Drugs and Dressings, £'s.

} equivalent to a  
} budget constraint.

HCO Hospital Consultant Obstetricians, man-hours.

HSR Hospital Senior Registrars, man-hours.

HRO Hospital Registrar Obstetricians, man-hours.

HSHO Hospital Senior House Officers, man-hours.

HMID/

HMID Hospital Midwives, man-hours.  
HNRS Hospital Nurses, man-hours.  
HCL Hospital Clinics, hours. (As DCL).  
HDD Hospital Drugs and Dressings, £'s.  
HCLK Hospital Clerks, man-hours.  
HBED Hospital Beds, bed-days.  
HLW Hospital Labour Ward, bed-days.

The resources required per unit of each activity, and the total resources available are summarised in Table 1. (The Appendix gives a detailed description of their derivation which should help Sunderland's decision-makers to judge whether the model is correctly specified).

Table 1 is on the next page.



TABLE 1

	DANC	HANO	HANI1	HANI2	HANI3	DCC	HEDC	HNSC	HLSC	HPNI	TOTAL AVAILABLE
DMID	0.38	0	0	0	0	24.4	7.25	1.5	0	0	42746
DCL	0.23	0	0	0	0	0	0	0	0	0	2561
DHV	0	0	0	0	0	0.49	0	0	0	0	650
DMO	0	0	0	0	0	1.13	0	0	0	0	1500
DDD	0.05	0	0	0	0	0.75	0	0	0	0	1600
HCO	0	0.03	0.2	0.54	0.18	0	0.34	0.52	0.65	0.23	2115
HSR	0	0.02	0.2	0.14	0.18	0	0.17	0.35	0.48	0.24	1527
HRO	0	0	0.27	0.98	0.25	0	0.59	0.84	1.01	0.33	2433
HSHO	0	0.04	0.52	0.3	0.47	0	0.41	0.87	1.21	0.62	3383
HMID	0	0.16	4.38	9.32	4.85	0	6.85	11.7	15.2	6.41	37130
HNRS	0	0.04	2.21	2.17	7.99	0	4.11	12.1	17.8	10.5	34163
HCL	0	0.04	0	0	0	0	0	0	0	0	899
HDD	0	0.05	2.3	0.54	2.08	0	1.46	3.54	5.04	2.76	11531
HCLK	0	0.06	0	0	0	0	0	0	0	0	1233
HBED	0	0	6.63	0	6.01	0	3.51	9.5	13.8	7.95	27935
HLW	0	0	0	1.56	0	0	0.71	0.71	0.71	0	2043

To these sixteen resource constraints must be added a demand constraint which states that the total number of pregnancies must equal the number actually taking place, which was 4113 in 1968. This constraint was labeled CBABY and took the form:

$$DCC + HEDC + HNSC + HLSC = 4113$$

It should be noted that this is expressed as an equality whilst all the resource constraints are inequalities. For example, HBED:  
 $6.63 \text{ HANI1} + 6.01 \text{ HANI3} + 3.51 \text{ HEDC} + 9.5 \text{ HNSC} + 13.8 \text{ HLSC} + 7.95 \text{ HPNI} \leq 27935.$

The technical coefficients were calculated on the assumption that all available resources were fully utilized in the short-run period of 1968. This is a fairly reasonable assumption as hospital and Local Health Authority decision-makers have reasonably good intuitive ideas of bed and staffing requirements, and the overall budget constraint ensures that there are few occasions of resources lying idle. However, the assumption does have an important effect on the output prediction of a linear-programming model. Full capacity implies a technically efficient point of production at which all the resource constraints intersect, and under such a situation a very small change in the relative-benefit weights can result in a totally unrealistic change in the predictive levels of output (see figure 1, page 120), or the range of relative-benefits that predicts a particular blend of output may/

may be very large (see figure 2).<sup>(\*)</sup> However, the MPS (Mathematical Programming System) print-out helps to determine the model's sensitivity, and the marginal cost ratios are designed to avoid the problem of these wide ranges.

Finally, the assumption of full capacity does not imply that there is no provision for emergency cases. Both planning authorities make allowance for such situations, and the technical coefficients have been derived from current (1968) practice, thereby implicitly including the spare units of resources planned to be left free. (For example, the hospital plans on an 80% bed-occupancy rate in order to leave 20% of bed-days spare for emergencies). If fewer emergencies were anticipated, the coefficients would be smaller.

The technology matrix (Table 1) is now used as a basis for describing the relative values of the ten types of maternity care provided by Sunderland Maternity Hospital and Local Health Authority in 1968.

Row/

(\*) : Recalling the hypothetical hospital of Chapter 3, (Figure 1); if the blend of output was at point D the efficient decision-maker would gradually reduce the quantity of doctor-hours available until the constraint also passed through point D. Only at times of major change in hospital policy are the constraints unlikely to pass through the same point.

Row 1 of Table 2 gives the marginal costs of these activities. (\*)

TABLE 2

	DANC	HANO	HANI1	HANI2	HANI3	DCC	HEDC	HNSC	HLSC	HPNI
1. MCs	0.3	0.3	12.5	11.7	14.4	19.3	18.0	27.2	35.7	18.7
2. Predicted provision	0	20893	343	0	1151	1236	1434	1443	0	0
3. Actual provision	11234	20902	364	43	84	1330	351	2313	119	21
4. Implied weights	0.3	0.3	3.7	9.5	9.5	19.3	14.2	19.6	25.3	12.5
5. Implied weights HEDC = 1	0.02	0.02	0.3	0.7	0.7	1.4	1.0	1.4	1.8	0.9

On the assumption that the ratio of marginal costs are equal to the ratio of the shadow prices, these marginal costs are used as the weights on the objective function and, given the resource constraints, predict the levels of activity shown in Row 2. These do not correspond well with the actual levels of provision shown in Row 3, largely because the 'full-capacity' model is very sensitive to changes in some of the weights, although other weights require large changes to produce different activity levels.

Row/

(\*) : Calculated by summing the products of the technical coefficients (of each activity) multiplied by the cost of their respective resource. Allowance is also made for laundry and catering costs.

Row 4 of the table shows the weights that will lead to a linear-programming solution which corresponds to the observed levels of provision. As Chapter 3 has shown, there is a range of weights which will predict any given levels of provision. The weights in this row are those which are nearest to the marginal costs but which will still yield the observed levels of output as the solution.

Row 5 is the same as row 4, but with 48-hour stay in hospital (HEDC) treated as numeraire, and gives the trade-offs in an easily discussable form.

An interesting example of the value of this descriptive approach is the very noticeable difference between the marginal costs and implied weights on the two activities : home confinement care (DCC) and hospital early-discharge care (HEDC). The difference cannot be explained by the model's sensitivity - a factor which can be tested by running the model with small changes in the weights and observing the effect on the levels of output predicted. Although the marginal cost data suggests that the two activities are of approximately similar value, the implied weights make it apparent that, given the present level of available resources and the technology observed in 1968, Sunderland's policy-makers consider that the benefit to the maternity population from an additional unit of home confinement care is greater than the benefit from an additional unit of early-discharge care. Whilst this may be true from/

from the domiciliary midwives point of view, and possibly also true for doctors in the north-east, it is contrary to national policy and the opinions of specialist obstetricians. (See Chapters 1 and 2). Earlier analysis of factors affecting the demand for maternity services suggested that the actual number of mothers receiving early-discharge care in 1968 was lower than what Sunderland Maternity Hospital and Local Health Authority supposed. Together with a recent policy decision to refuse hospital beds to certain mothers, there would appear to be considerable evidence justifying a re-evaluation of early-discharge care and the reallocation of resources to expand this activity. This will be considered in a later section of the chapter.

As far as the supply of antenatal care is concerned, Table 3 provides the same information as rows 1, 3, 4 and 5 of Table 2, but out-patient antenatal care at home and hospital (DANC and HANO respectively) is measured by the number of cases rather than the number of attendances. (The appendix shows that each mother makes approximately 8.0 visits). This makes comparison with the other activities more comprehensible.

TABLE 3/

TABLE 3

	DANC	HANO	HANI1	HANI2	HANI3	DCC	HEDC	HNSC	HLSC	HPNI
1. MCs	2.4	2.4	12.5	11.7	14.4	19.3	18.0	27.2	35.7	18.7
3. Actual provision	1404	2613	364	43	84	1330	351	2313	119	21
4. Implied weights	2.4	2.4	3.7	9.5	9.5	19.3	14.2	19.6	25.3	12.5
5. Implied weights HEDC = 1	0.2	0.2	0.3	0.7	0.7	1.4	1.0	1.4	1.8	0.9

Although antenatal care is not strictly comparable with confinement care, it would be worth checking whether doctors agree that the value of an additional unit of early-discharge care (HEDC) is five times more beneficial than eight antenatal attendances, for this appears to be the value that they are putting on these two types of care. Discussion with the doctors on these relative values might prove of interest to future planning policies.

So far, the model has been used only for descriptive purposes. The technology, the total available resources, and the actual output levels of each activity have been described and measured, and the inverse of a simple linear programming model was used to describe the weights implicit in doctors' decision-making on the assumption that they (the doctors) are acting as if they wish to maximise the total benefit of the services/

services provided to the maternity population.

Now that these weights have been made explicit, the model may be used for medium run planning to measure the effects of changes in doctor preferences, in resource supply, and in the technology.

#### A Policy to Decrease the Number of Domiciliary Confinements

The difference between the marginal costs and the implied weights of home delivery care and hospital early-discharge care drew attention to the possibility that the providers of Sunderland County Borough's maternity services are overvaluing the benefit of home confinement relative to early-discharge care. The model is now used to examine the effects of a change in policy in favour of early-discharge.

##### (a) In the Short-Run

The model will show that no change in output levels is possible without an increase in labour-ward capacity, and that, even if this is possible in the short-run, the quantity of other (fixed) resources which would have to be switched from normal-stay care (HNSC) to early-discharge care (HEDC) would provide for so few normal-stay cases as to be medically unacceptable.

Assuming that the total number of confinements remains constant/



constant at 4113, and that the hospital and local health authority are technically efficient, examination of Table 1 reveals that there must be an increase in the total amount of those resources used by early-discharge care (HEDC) if this activity is to be expanded. In the short-run the total amount of available resources is fixed, with the result that these scarce resources will have to be shifted from other activities. It is unlikely that the hospital will be willing to reduce the quantity of long-stay care (HLSC) as this is care reserved specifically for 'high-risk' cases requiring the extra care; and ignoring the possibility of reducing the quantity of antenatal care in order to provide some of the scarce resources, the hospital will have to shift mothers from normal-stay care to early-discharge, thereby creating slack in all resource levels - except in labour-ward bed-days.

The technology relating labour-ward bed-days to both early-discharge care and normal-stay care is the same, which implies that any shift in the allocation of labour-ward bed-days from normal-stay to early-discharge will result in no slack which could be used in the provision of early-discharge care for those cases at present being delivered at home. Unless, therefore, the labour-ward technology can be changed, or its facilities expanded, no policy change can be effected. The occupancy-rate for the labour-ward in 1968 was 50.7% of the total labour-ward bed-days. This low figure is probably due to the random incidence of the onset of labour and the/

the need to allow a lot of slack for emergencies. For the present discussion it is assumed that this occupancy-rate can be increased to 59.6%, which will have the effect of increasing the total quantity of labour-ward bed-days from 2043 to 2398 bed-days.

The only change in the descriptive model so far has been this increase in the total amount of labour-ward bed-days. Using this amended technology matrix, the model investigates the effect of increasing the relative value of hospital early-discharge care (HEDC) in order to shift mothers from home delivery (DCC) to hospital delivery. HEDC is manipulated rather than DCC because it is planned to use hospital resources at present allocated to normal-stay care (HNSC) for the additional early-discharge care. In other words, the value of HEDC is expected to increase relative to DCC and HNSC.

Using the original implied weights of row 4, Table 2, with the amended technology matrix, the predicted levels of output remain unchanged from row 3. Gradually increasing the value of early-discharge care from 14.2 to the marginal cost value of row 1 (18.0) still has no effect on the predicted levels of output. Only when the weight exceeds the value at present being put on home confinement care does the blend of output change. This is shown in Table 4.

TABLE 4

Actual Provision	1330	351	2313	119	4113
	DCC	HEDC	HNSC	HLSC	TOTAL
New Weights	19.3	19.5	19.6	25.3	-
Predicted Provision	830	2059	1105	119	4113
Change	-500	+1708	-1208	0	0
% Change	-38%	+486%	-52%	0%	0%

The total number of home deliveries falls by 38% from 1330 to 830 cases, thereby making the proportion of hospital confinements 80% of all deliveries, which is in line with current national policy. Further reduction in the number of women confined at home is limited by the labour-ward's capacity.

The increase in the number of early-discharge cases (HEDC) which enabled this reduction in the number of home deliveries to be accomplished was only achieved by a massive switch of resources from normal-stay (HNSC) to early-discharge care. The result of this is that the total number of women now receiving normal-stay care has to be reduced by over 50% from 2313 to 1105 cases. Such a major change in hospital discharge policy is unlikely to be medically acceptable because many of the 1208 cases transferred from HNSC to HEDC require (on medical efficiency criteria) more than two days hospital care. Such a response would be equivalent to doctors implicitly increasing the weight that they are putting on/

on normal-stay care, and this would have the effect of shifting output back to the original observed levels.

The transferring of these 1208 cases can, however, be interpreted not as a direct transfer but as the equivalent of a reduction in the average length of stay for normal-stay care from eight lying-in bed-days to five bed-days (7.95 to 4.82). Shifting back the distribution of bed-days for existing normal-stay care has the effect of releasing those resources which are used to staff and equip a normal-stay bed-day - in other words, of indirectly increasing the resources available. For more specific details, see the Appendix, especially Table 9, page 1637. Whilst such an interpretation is as unlikely to be acceptable as a direct transfer, and the conclusion drawn that a policy to increase the hospital confinement-rate by expanding early-discharge care is impossible from the medical point of view in the short run when resource levels are fixed, this approach becomes valuable when resource levels can be expanded. As the time period increases, a policy to increase the hospital confinement-rate may become desirable, and the use to which the additional resources may be put, together with the cost of the increase, gives a useful cost effectiveness argument for the expansion.

(b) Increasing the Total Amount of Available Resources

The/

The model is now used to show what resources are required if the short-run average length of stay for normal-stay cases (after the shift of output to an 80% hospital confinement rate) is to be increased from 4.8 to 7.2 bed-days. The computer print-out on the short-run investigation into the provision of early-discharge care to women at present being confined at home revealed that when doctors' evaluations of the relative benefits from these two types of care had changed in favour of early-discharge care, the resultant change in output levels created a considerable quantity of slack in some resources. Table 5 shows the quantities of slack available when the blend of output has changed in favour of early-discharge care - see Table 4. There has been no increase in the total available resource levels (except HLW).

TABLE 5

<u>Resource</u>	<u>Slack Available</u>
DMID	1640
DHV	244
HCO	46
HSR	132
HRO	0
HSHO	359
HMLD	2416
HNRS	7563
HBED	5481

The most notable of these is the 5481 bed-days which are unused. If these 5481 bed-days are distributed equally between the 2313 normal-stay cases, each case could have an extra 2.36 bed-days, and the average length of lying-in stay would increase from the medically infeasible five bed-days to seven bed-days (4.82 to 7.18), which is only three-quarters of a bed-day less than the original described average length of lying-in stay. If the total available quantities of those resources which are limiting expansion could be increased, the policy to increase the proportion of hospital confinements to 80% may become qualitatively feasible.

Table 6 gives the resource quantities required by the 5481 bed-days.

TABLE 6

<u>Resource</u>	<u>Resources Required</u>
HCO	118
HSR	33
HRO	225
HSHO	68
HMID	2006
(HDD	124)

Increasing the right-hand side of the technology matrix

(Table/

(Table 4) by these quantities, and running the model with the original implied weights leaves the levels of output unchanged from that described by row 3, Table 2. Only when the doctors' evaluation of early-discharge care exceeds the value they put on home confinement care does the blend of output change - see Table 7.

TABLE 7

Actual Provision	1330	351	2313	119	4113
	DCC	HEDC	HNSC	HLSC	TOTAL
New Weights	19.3	19.5	19.6	25.3	-
Predicted Provision	830	1144	2020	119	4113
Change	-500	+793	-293	119	-
% Change	-38%	+226%	-13%	0%	0%

As before, the number of home confinements falls to 830 so that the hospital confinement-rate stands at 80%, but instead of having to shift 1208 normal-stay cases to early-discharge care to create spare capacity, the increase in the total amount of available resources means that only 293 normal-stay cases have to be transferred. Again, this can be interpreted as a reduction in the average length of lying-in stay for all 2313 normal-stay cases - a reduction from eight to seven (7.95 to 7.28) bed-days, which is unlikely to meet with much medical opposition.

This/

This calculation shows that a change in the value that doctors put on each activity can lead to a major change in the blend of services supplied, provided that there is a small change in particular resources. The model suggests, by means of additional information contained in the MPS print-out, which resources should be expanded and by how much. It also shows that the hospital cannot respond to such a change in the relative values without some increase in at least one resource. The fact that most resources have to be expanded by some amount is the result of the initial assumption of technical efficiency; the fact that some resources have to be expanded by greater amounts than others indicates areas where bottlenecks might have occurred had the information contained in the MPS print-out not been available. Finally, to increase all the resource quantities by the amounts necessary to expand one activity will be more expensive than an increase in some of the resources combined with a reallocation of resources between activities. It must be stressed, however, that the provision of early-discharge care to the 500 home confinement cases is achieved, not only by the direct cost of increasing staff (and labour-ward) resources, but also by the 'qualitative cost' of shifting 293 (13%) normal-stay cases to early-discharge care - or by reducing the average length of stay for the 2313 normal-stay cases from eight to seven lying-in bed-days.

(c) Increasing the Flexibility of the Labour Force

One/



One of the major conclusions of the 'quality' investigation was that domiciliary and hospital midwifery staff should be merged. Although no additional midwifery resources are created, the increased flexibility resulting from the merger would enable those domiciliary midwives hours which were in slack supply when the hospital confinement rate was increased by 80% to be reallocated to meet the increased demand for hospital midwives. (Compare Tables 5 and 6). For the purposes of this model, the two midwifery constraints (DMID and HMID) are summed together to become:

$$\begin{aligned} \text{MID} = & 0.38 (\text{DANC}) + 0.16 (\text{HANO}) + 4.38 (\text{HANI1}) + 9.32 (\text{HANI2}) \\ & + 4.85 (\text{HANI3}) + 24.4 (\text{DCC}) + 14.1 (\text{HEDC}) + 13.2 (\text{HNSC}) \\ & + 15.2 (\text{HLSC}) + 6.41 (\text{HPNI}) \leq 79876. \end{aligned}$$

Secondly, data from the MPS print-out showed that, when the weight on early-discharge care was increased in the short-run, certain doctor resources were more scarce than others - they commanded a higher shadow price. Table 5 shows this in a different way - when output shifts, there are slack quantities of consultant, senior registrar and senior house officer man-hours, whilst the scarcity of registrar man-hours is limiting further reallocation. As it is probable that there is a certain amount of flexibility between the different grades of doctor, it is assumed that senior registrar (HSR), registrar (HRO), and senior house officer (HSHO) skills are substitutable. The consultant was of the opinion that early-discharge care did not require his specialist skills at confinement/

confinement, and so we have chosen to merge the HSR, HRO and HSHO constraints into one:

$$\begin{aligned} \text{HDOC} = & 0.06 (\text{HANO}) + 0.99 (\text{HANI1}) + 1.42 (\text{HANI2}) + 0.90 (\text{HANI3}) \\ & + 1.17 (\text{HEDC}) + 2.06 (\text{HNSC}) + 2.7 (\text{HLSC}) + 1.19 (\text{HPNI}) \leq 7343. \end{aligned}$$

These two new resource constraints are substituted into the technology matrix.

The purpose of this section is to show that an increase in the flexibility of the labour force can reduce the bottleneck effect of certain scarce resources limiting output. As in the previous sections, the model will be used to investigate a policy of increasing the hospital confinement rate to 80% by increasing the value of early-discharge care. As before, labour ward capacity is increased to make allowance for the increase in hospital confinements.

Using this amended technology matrix with the original weights (Table 2, row 4) leaves the predicted levels of output unchanged from the observed output levels (Table 2, row 3). Increasing the weight on early-discharge care to 19.5 leads to a reallocation of resources, and the predicted levels of output change so that the 80% hospital confinement rate is achieved. In the short-run, with no flexibility in the labour force, this was achieved at the expense of a 52% reduction in the number of normal-stay cases. Without any increase in the quantities available, a more flexible labour force enables the same objective to be realised, but at the expense of a 41%/

4.1% reduction in normal-stay cases - see Table 8.

TABLE 8

Actual Provision	1330	351	2313	119	4113
	DGC	HEDC	HNSC	HLSC	TOTAL
Weights	19.3	19.5	19.6	25.3	-
Predicted Provision	830	1798	1366	119	4113
Change	-500	+1447	-947	0	0
% Change	-38%	+412%	-41%	0	0

Whilst this would probably not be enough to satisfy the medical efficiency criteria, it is a definite advantage.

This advantage can be seen to even greater extent when the MPS print-out on shadow prices is consulted. This shows that the 80% hospital confinement rate could be achieved with even less of a reduction in the number of normal-stay cases if the total quantity of HCO was increased. If we assume that an additional sixty hours of consultant time can be purchased, the blend of output will change again, so that only 656 normal-stay cases have to be transferred to early-discharge care - a reduction of only 28% on the original 2313 cases. See Table 9.

TABLE 9/

TABLE 9

Actual Provision	1330	351	2313	119	4113
	DCC	HEDC	HNSC	HLSC	TOTAL
Weights	19.3	19.5	19.6	25.3	-
Predicted Provision	830	1507	1657	119	4113
Change	-500	+1156	-656	0	0
% Change	-38%	+330%	-28%	0	0

At this point, approximately eight consultant hours are lying idle - the resource that is now limiting further expansion is HDOC. The removal of the consultant bottleneck, combined with the flexibility in the midwife and other medical staff resources, has enabled the 80% hospital confinement rate to be achieved together with a significant reduction in the number of normal-stay cases who had to be transferred to early-discharge care.

Increasing the Quantity of Hospital Out-Patient Antenatal Care (HANO)

Chapters 1 and 2 drew attention to the fact that the hospital antenatal clinic was operating at more than full capacity - some women were having to wait so long that they left before they had been examined. It is acknowledged that this may be due, in part, to the attenders' unwillingness to use an appointment system, but the position has now been reached where, if this hospital service is to expand and also to maintain a high standard of care, additional resources/

resources will have to be reallocated from other activities.

In this section, the model is used to experiment with different solutions to the problem on the assumption that the benefit from hospital out-patient antenatal care (HANO) is being undervalued relative to hospital confinement care (HEDC and HNSC). The possibility of the hospital delegating some of its routine antenatal attenders onto the community (general practitioner and local health authority) is not investigated here because it is assumed that the planning authorities are anxious to maintain continuity of care. It is proposed that the hospital should increase its capacity to cope with an additional 2640 attendances, which is equivalent to an extra 330 new bookers making eight visits to the clinic.

Ignoring the possibility of meeting these additional attendances by further reducing the quality of the antenatal service (i.e. using the same quantity of resources to provide care for more cases which implies less of each resource per attendance), inspection of the technology matrix reveals that it is not possible to switch hospital clinic (HLC) or hospital clerical staff (HCLK) resources to HANO from another activity. This means that, in the very short-run, the problem is insoluble. The 2640 additional attendances require 113.5 hours of clinic time and 156 hours of clerical staff time, and neither has any slack immediately available.

As the time period increases it should be possible to recruit additional clerical staff within a fairly short space of time. On the other hand, additional clinic hours may be more difficult to find, as other out-patient sessions are held in the same building and impinge upon the opportunity for working additional hours. There are two possibilities, excluding the building of a larger clinic, which might lead to the creation of additional clinic hours.

(a) By improving the 'technical' efficiency of the clinic's operation. This is a problem suited to the particular skills of the work study analyst and, therefore, outside the scope of this thesis. However, as there had been a recent work study conducted on the clinic, such a possibility was not further investigated.

(b) There may be times in the day, or evening, when the clinic is not in use, and when expectant mothers would be willing to attend. From discussions with the midwifery staff, this possibility was considered feasible, and has been adopted here.

Allowing hospital clinic (HCL) and clerical staff (HCLK) to increase by 114 and 156 hours respectively, and increasing the weight on HANO reveals that a bottleneck develops around domiciliary midwives (DMID), which prevents normal-stay cases (HNSC)/

(HNSC) being shifted to early-discharge care (HEDC). Only after the quantity of available domiciliary midwives has been increased can resources be shifted from normal-stay to early-discharge care, thereby creating sufficient slack in resource levels for HANO to increase. Table 10 shows the predicted levels of output when there is an increase of domiciliary midwives' time of 5%, from 42746 to 44883 hours, and the weight on HANO is increased from 0.3 to 0.9.

TABLE 10

Actual Provision	11234	20902	1330	351	2313
	DANC	HANO	DCC	HEDC	HNSC
New Weights	0.32	0.88	19.3	14.18	19.59
Predicted Provision	11234	23196	1330	723	1941
Change	0	+2294	0	+372	-372
% Change	0%	+11%	0%	+106%	-16%

At this level of output, shortage of domiciliary midwives again creates a bottleneck which prevents further expansion of HANO. Reviewing what has occurred: As a result of a policy to increase HANO, scarce resources were planned to be reallocated from normal-stay to early-discharge care, thereby creating slack which might be used for the provision of additional antenatal (HANO) care. Such a policy was only possible after the removal of bottlenecks around HCC, HCLK and DMID. It is interesting that/

that if the midwifery services were unified, the 5% increase in DMID could be reduced to 1.7%.

Although HANO has increased by 11%, this is not up to the planners' initial expectations. Assuming that additional quantities of domiciliary midwives are not available, even in the medium run, predicted output levels will not change again until the weight on HANO is increased beyond 1.67.

TABLE 11

Actual Provision	11234	20902	1330	351	2313
	DANC	HANO	DCC	HEDC	HNSC
New Weights	0.32	1.67	19.3	14.18	19.59
Predicted Provision	10382	23542	1330	779	1885
Change	-852	+2640	0	+428	-428
% Change	7.6%	+12.6%	0%	+112%	-18.5%

Table 11 shows that if resource levels are not allowed to expand further, increasing the weight on HANO not only leads to an increase in the number of normal-stay cases that have to be shifted to early-discharge care, but also leads to a reduction in the number of domiciliary antenatal attenders that can be provided with care. As the number of home confinements has not decreased, such a solution is unlikely to be 'qualitatively' acceptable. Putting a constraint on domiciliary antenatal care (DANC) such that output is held at 11234/



11234 leads the model to predict a blend of output similar to that shown by Table 10. The significant change, however, lies in the value of the shadow price on hospital consultant time (HCO), which increases by over 200%.

This information suggests that the most satisfactory solution to the problem would be to increase the quantity of HCO available. On the assumption that this is feasible in the medium time period, HCO was allowed to expand by 37 hours. This, in itself, proves to be insufficient as a bottleneck immediately develops around senior registrar time (HSR), so that an extra 23 HSR hours are required. Once these two resource levels have been increased the model predicts the following levels of output:

TABLE 12

Actual Provision	11234	20902	1330	351	2313
	DANC	HANO	DCC	HEDC	HNSC
New Weights	0.32	0.46	19.3	14.18	19.59
Predicted Provision	11234	23542	1330	571	2093
Change	0	+2640	0	+220	-220
% Change	0%	+12.6%	0%	+63%	-9.5%

This/

This shows that a small increase in the levels of HCO and HSR available not only enables the planners' objective for the additional 2640 HANO attendances to be achieved, but also considerably reduces the number of normal-stay cases that have to be shifted to early-discharge care.

Finally, the model is used to investigate one other solution to the problem which was suggested by information contained in the Mathematical Programming System (MPS) print-out. On several trial runs, the shadow price on the hospital labour ward (HLW) suggested that this resource was worth expanding.

This suggestion was easily investigated by allowing the total quantity of available HLW to increase from 2043 to 2398 bed days (an amount similar to that used in the previous section), and, with DANC held constant at 11234 attendances, observing what happened to the predicted blend of output as the weight on HANO was increased. Table 13 shows that, when this was increased to 3.16, the predicted levels of output changed from the actual observed output to:

TABLE 13/

TABLE 13

Actual Provision	11234	20902	1330	351	2313
	DANC	HANO	DCC	HEDC	HNSC
New Weights	0.32	3.16	19.3	14.18	19.59
Predicted Provision	11234	23542	939	1911	1144
Change	0	+2640	-391	+1560	-1169
% Change	0%	+12.6%	-29.4%	+44.5%	-50.5%

Although this solution is as qualitatively infeasible as some solutions in the previous section, there are a couple of details which are of interest. The first is that the shadow price on hospital consultant time (HCO) suggests that if this resource could also be expanded, the drastic shift of normal-stay cases to early-discharge care would be considerably reduced. (This is comparable to section (c) of 'A Policy to Decrease the Number of Domiciliary Confinements'). Secondly, information from the print-out on the weights put on the objective function suggests that, at this blend of output, the weight on HEDC is nearer 19.4 than 14.2. This accords well with the findings of the previous section that, if the quantity of domiciliary confinements was to decrease, the weight on HEDC had to be increased to 19.5.

The purpose of including this short 'addendum' is not so much to investigate another way of solving the hospital antenatal/

antenatal clinic problem, but rather to illustrate the adaptability and reliability of the model. The technique allows changes to be made in one part of the model while others are held constant, so that the planner is always aware of the consequences of a particular policy decision. Any subsequent change in policy - maybe prompted by information contained in the MPS print-out - can be evaluated within the space of a few seconds on the computer, instead of by trial and error within the actual hospital and community.

Figure 1

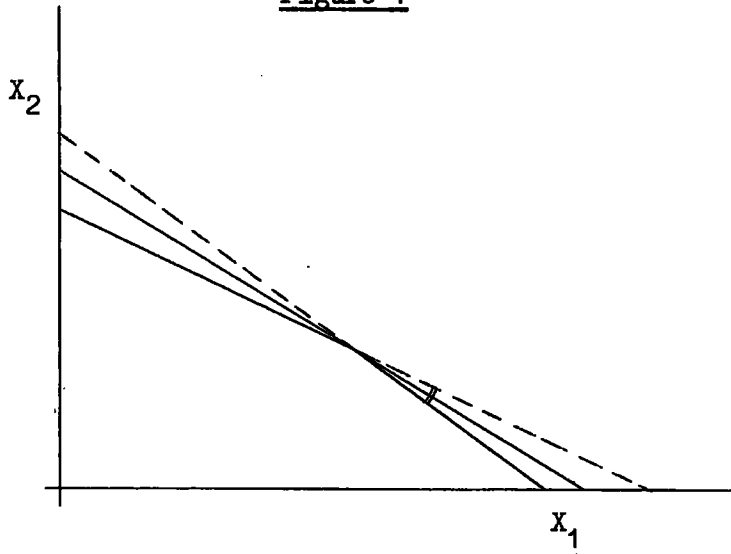
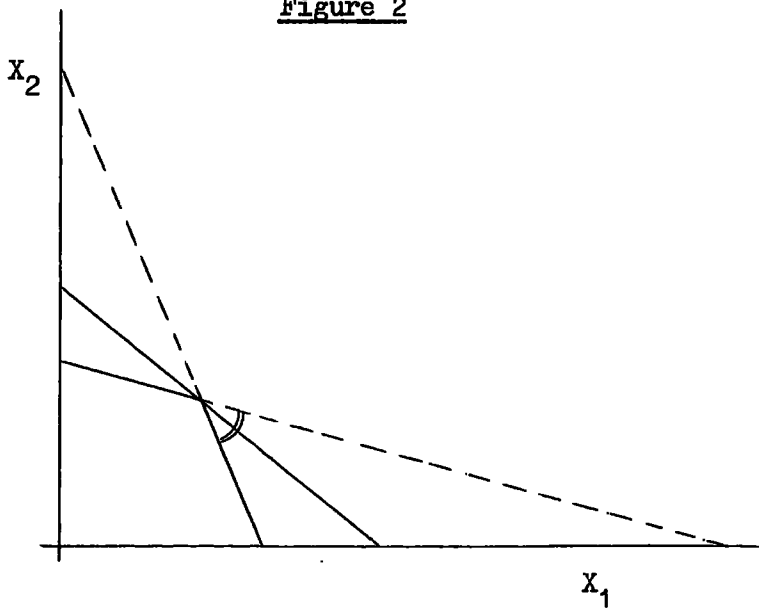

Figure 2



CONCLUSION

"The challenge facing us all is how to make the best use of medical resources in order to provide the highest possible quality of personal care." [Quoted in Introduction].

The primary purpose of this thesis has been the development of a medium run economic planning model that would provide the health service administrator with information which would help him to solve the immediate question: "Given a fixed supply of resources, and little chance of a major change or expansion during the next few years how should they be allocated between the many beneficial services that the community requires?" It is immediately assumed, therefore, that the health service administrator is attempting to maximise total benefit to the community from the services provided, or that he is attempting to minimise the risk of mortality and morbidity to the community.

The health service administrator has very little objective information relating to the relative social values of the various services provided, and even less idea of the risk of morbidity as presented in probability terms. Whilst many administrators can acquire expertise in making intuitive judgments of relative values future planning is little more than a trial and error situation within the medical care system itself and can, therefore, result in misallocation of resources.

The factors leading up to a decision to increase the provision of activity A may be exceedingly complex and involve consideration of internal political pressures and public demand, but the fact that activity A was chosen for expansion indicates that this was revealed preferred over all other activities. If, therefore, management is assumed to be attempting to maximise social benefit they are implicitly saying that the expenditure on providing an additional unit of this activity would yield greater total benefit than if spent in providing an additional unit of activity B. Similarly, if a reallocation of resources is employed as a means to relieving what management believes to be an area of greater need then they are implicitly saying that the relative values have changes (or at least been recognised), and a new blend of provision is required.

However, administrators have only recently begun to think in terms of opportunity costs, and there is little data relating to the definition and measurement of service output and the technology relating inputs to outputs. ". . . information of this type has not been collected in the past because health service planning decisions were made on the basis of whether a particular project would make some improvement in health and not on the quantitative assessment of the size of that improvement or a comparison of the outputs that could be obtained from different projects." Feldstein, 1966. Traditional cost-benefit analysis, to which Feldstein was referring/

referring, has proved a useful tool for evaluating the relative values of two or more similar projects where errors in computation are likely to cancel themselves out, and it has the great advantage of making planners think of alternative courses of action, and the implications of action not only to those directly concerned but also to society. The major problem has always been the valuing of goods which do not command a market price, and in the health field these are particularly difficult - see Schelling, 1965.

The model presented here uses much the same kind of data that cost-benefit analysis requires - the definition of output, its measurement and relationship to inputs available - but instead of the economist running the risk of letting his own value judgments influence the prices which he puts upon the benefits, the current levels of output and the present technology are used to show what the administrators' implicit relative values must have been. In itself this is not an optimising model, but once these values have been made explicit then objective information is available to administrators in a readily discussable form, and from which they can go on to re-think their priorities.

Because the derivation of these weights was the immediate concern, maternity care services in Sunderland were chosen for examination so as to minimise the problems of definition and measurement of outputs. Even so, it was necessary to devote considerable/



considerable time and space to examining the present supply of maternity care and the demands made upon it. This enabled certain aspects of the quality of care to be examined in terms of utilisation and need, and also a check to be made that the model was correctly formulated and each activity relevant to the overall question: "what is its value with respect to the other activities; are they in fact realistic comparisons and will they be relevant for helping to plan future levels of maternity care?" Although these first two chapters were mainly descriptive, they suggested areas of possible under-provision and formed the basis of the questions which the economic model was then used to investigate.

This model relied upon the definition of mutually exclusive outputs and the measurement of the technical coefficients relating inputs to these outputs during the period of one year (1968), and these were then used in an inverted linear programme to derive the weights on the objective function that would have predicted, if used in a traditional linear programme, the observed (1968) levels of output. As there is a range of values associated with each weight, first approximations of marginal benefit were derived from short-run unit costs on the welfare assumption that the ratio of the marginal benefit of activity A to the marginal cost of activity A must equal the corresponding ratio for activity B. After the initial computer run the MPS print-out contained information relating to the size of these ranges and the effect on output of moving beyond their limits.

The Sunderland model confirmed the suggestion of the earlier chapters that certain activities appeared to be under-valued and, therefore, the weights on the objective function were altered to simulate changes in the administrator's intuitive value judgments.

Because of the method of data collection (there was no operational research into the technical efficiency of the input-output relationships) the model was defined as running at full capacity with no slack in any of the resources available - which tended to make it sensitive to some small changes and insensitive to other major changes. However, by allowing certain variables to change while holding the remainder constant it was possible to use the model for predictive purposes.

These predictive exercises revealed the complicated nature of the technology and, more interestingly, the value of an approach which enabled some resources to be expanded and others to be reallocated within a described situation as the weights on the objective function changed. Each investigation revealed that reallocation of existing resources from one activity to another was an infeasible method of changing output levels in the short-run, but it was found that when one or more resource levels were allowed to expand then reallocation was a more economically efficient solution than the expansion of all the resource levels involved in that activity which was to be increased. The model also showed that  
if/

if doctors considered the shift in the blend of output to be medically infeasible, then this was equivalent to another change in their priorities such that output would return towards its original level.

A factor which only briefly emerged in the discussion but which merits more attention is the effect of changes in the technical coefficients. Traditional linear programming treats the technical coefficients as fixed, but in the medical care situation they are very likely to be variable.

In the economic model the coefficients were calculated from existing records relating to services provided and resources employed during 1968, and the quality of the production process was assumed to be 'in control' [Brems, 1968, has made the point that economic theory thinks of quality as something non-quantitative or even purely subjective, and he suggests that "the physical quality of a product is uniquely determined once all the input and capital coefficients of its production process have been specified. . . . Statistical quality control in mass production is based upon the idea that given the production process, results of quality measurements of the individual units of the product will vary at random between an upper and lower control limit. If these limits are exceeded the process is not in control."]. This means that the input proportions for a unit of each activity were assumed to be qualitatively (technically) efficient for a mother receiving that particular pattern of care.

Inefficiency/

Inefficiency could only exist in the allocation of mothers to the various patterns of care available; or, put another way, in the allocation of total resources to the specified production process. The most that the model will do to ensure technical efficiency is to provide planners with the input and output information which could provoke discussion and a change of technical policy.

If planners decide that a particular activity could be qualitatively improved by an injection of resources and increasing the technical coefficients, they are once again implicitly saying that the return from the expenditure on an activity which uses more resources is greater than the return from a similar expenditure elsewhere. When the change in the technology has been incorporated into the production matrix, it is found that the range on the objective function's weights has increased at the upper limit, thereby adjusting to the fact that the relative value of the activity using more resources has increased. Moreover, it would be possible to show the level of the qualitative change in cost-effectiveness terms.

However, it is possible that, as management decides to change the blend of output by an increase in some resource levels and a reallocation of others, some of the resultant 'slack' will still be employed, and the technical coefficients will thereby in practice change. In such a situation it is very difficult to judge whether this/

this 'slack' employment actually contributes to the quality of a unit of output. The model will tell management what levels of slack resources they can expect from a change in policy, ceteris paribus, and any deviation from this can, therefore, be examined. However, the model itself will, if slack resources are maintained in employment, automatically predict an increase in quality. As both Reder, [1969], and Culyer, Lavers and Williams [1970], have pointed out, a meaningful measure of 'quality of output' must be derived independently of input units. Fortunately, as far as the economic model developed here is concerned, this is only a limitation, not an invalidation of its application, and it stresses the importance of combining the economic model with statistical and sociological research similar to that contained in Chapter 2.

The thesis has shown that an inverse programming approach to the problem of resource allocation within the maternity care sector of the National Health Service does provide administrators with objective information relating to the relative benefits of the patterns of care available, and in so doing also provides valuable information relating to the technology. This information can then be used for investigating changes in the technology, resource levels and the administrators' priorities, which would otherwise have had to be carried out by a controlled trial within the medical care system itself.

The/

The next stage will be to apply the technique to an 'area health board' situation where the major problem will not be one of checking the validity of the method, but rather of classification and measurement of output and the production process.

APPENDIX

Deriving the Technology Matrix

This appendix describes the derivation of the technical coefficients relating the services provided to maternity care patients and the resources used in this provision. A detailed approach is necessary because the descriptive reliability and predictive validity of the economic planning model is dependent upon an accurate formulation of the technical production process.

Ideally, work study techniques should be used to investigate the technical relationship between inputs and outputs, but limitations in research resources necessitated the more modest approach of using the statistical data which was already collected by the various planning authorities.

The Services Provided

As has been pointed out in Chapter 4, it was convenient to categorise maternity care into ten mutually exclusive but not exhaustive activities. In the case of maternity care, such an exercise is not complicated to any significant extent by wide variations and multi-diagnoses in case-types and care provided, and data on the number of women receiving care in these particular categories was readily available from the local health and hospital authorities' returns.

1. Domiciliary Antenatal Care (DANC). The Report of the Medical Officer of Health for 1968 states that there were 11,234 'antenatal visits and attendances (at clinic)'. This does not include visits by midwives or health visitors to mothers' homes included in domiciliary confinement care (DCC), nor visits that expectant mothers made to their general practitioners not included in the model. Of the 11,234 visits and attendances, 1508 were 'New Bookings' which represents an average of 7.4 visits per new booking. If the number of cases booked for home confinement is used instead, there were approximately 8 visits per booked home confinement.

2. Hospital Antenatal Care : Out-Patients (HANO). The hospital returns for 1968 showed that there were 20,902 attendances at the hospital's antenatal clinic, composed as follows:

New Bookings	2679
Return visits	15590
Consultations	1495
Out-patients	1135
Refused bookings	<u>3</u>

TOTAL 20902

This represents an average of approximately 7.8 visits per new booking.

3. Hospital Antenatal Care : In-Patients (HANI). It was necessary/



necessary to divide the specialist antenatal care that mothers receive as in-patients into three different types on account of the varying lengths of stay and levels of care relative to the number of staff on particular wards.

HANI 1 refers to the 364 expectant mothers discharged from Ward D with an average length of stay (ALOS) of 6.63 days.

HANI 2 refers to the 43 expectant mothers discharged from the Labour Ward with an ALOS of 1.56 days.

HANI 3 refers to the 84 expectant mothers discharged from Wards A, B, C and F with an ALOS of 6.01 days.

4. Domiciliary Confinement Care (DCC). Apart from the care provided to a mother when she is in labour, expectant mothers receive home visits from midwives and health visitors. (Since 1968, the health visitors' work has been taken over by midwives). These prenatal home visits were a particular problem because it would have been more correct to have treated them as a separate activity (or service). However, measurement was impossible because classification was complicated by visits made to mothers in false labour, or cases where a midwife on night-duty was relieved during a confinement visit but before the baby was born. For this reason, all 'antenatal home visit' returns have been allocated to domiciliary confinement care.

Secondly,/

Secondly, mothers and children are provided with nursing care by the midwives for the first ten days post-delivery. After the tenth day, the health visitors take over, but in this model any care received after the tenth day is excluded.

In 1968, the Medical Officer of Health reported 1330 mothers receiving confinement and nursing care in their homes, and a further 67 who were booked for domiciliary delivery but were in fact admitted to hospital.

5. Hospital Confinement Care. Mothers going to the Sunderland Maternity Hospital for delivery are booked as either 'early-discharge' cases or '10 day stay' cases. As Table 1 (page 154) shows there is no strict adherence to these booking arrangements - if complications develop, then the length of stay might well have to be increased beyond 10 days. Similarly, if a mother and child do well, they may be discharged earlier than anticipated. As types of care can be readily identified by length of stay, and are accepted by hospital staff for booking arrangement policy, it seemed reasonable to divide hospital confinement care into:

(a) Hospital Early-Discharge Care (HEDC). This was defined as those cases discharged after only two or less lying-in days post-delivery. Table 1 shows that in 1968 there were 351 such cases with an ALOS of 1.96 days.

(b) Hospital Normal-Stay Care (HNSC). This was defined as those cases discharged within three to ten lying-in days post-delivery/

delivery. In 1968 there were 2313 mothers discharged with an ALOS of 7.95 days.

(c) Hospital Long-Stay Care (HLSC). In 1968, 119 cases required in-patient care for longer than ten days. Although the ALOS was 12.27 lying-in days, the range extended to twenty-six days. (See Table 1).

6. Hospital Postnatal Care : In-Patients (HPNI). The hospital returns also showed that twenty-one mothers were admitted from home for in-patient post-delivery care. Their ALOS was 7.95 days.

These are the ten activities that were considered relevant to the problem of allocating resources between the services provided to expectant mothers. Before examining the resources used by these activities, the overall picture should be completed by drawing attention to the special nursery ward which, in 1968, provided intensive care for 911 babies. As this is a self-contained unit employing its own staff, and as the care it provides is not a direct substitute for any of the ten activities outlined above, this activity was not considered relevant to the immediate problem, and was omitted from the model's specification.

#### The Resources Required

1. Domiciliary Midwives (DMLD).

(a) Domiciliary Antenatal Care (DANC). From the time-sheets kept/

kept by each midwife it was possible to calculate that domiciliary midwives worked at 1603 sessions in 1968. This figure represents more than the actual number of clinic sessions because many clinics are staffed by more than one midwife. So as to avoid confusion with clinic sessions, these 1603 will be referred to as midwife-clinic sessions. Each clinic session has a formal running time of two hours, but further examination of midwife time-sheets showed that clinics often ran for longer than this, and the average of two hours thirty-six minutes from a sample month of returns was used as the approximate length per session (Table 2). This implied that domiciliary midwives spent a total of  $1603 \times 2.65 \approx 4248$  hours on antenatal clinic care. As there were 11234 attendances at these clinics in 1968, each attender must have used:

$$\frac{4248 \times 60}{11234} \approx 22\frac{1}{2} \text{ midwife minutes. (Throughout this appendix (x) = 'multiplied by').}$$

In other words, the average amount of time that midwives were devoting to one expectant mother on one visit to the clinic was  $22\frac{1}{2}$  minutes. It is not implied by this that each visit by an expectant mother necessarily should (or does) take  $22\frac{1}{2}$  minutes of a midwife's time - some may well take longer, others a shorter time. This coefficient, and the others that follow, is only an average with a fairly wide dispersion around it.

(b) Domiciliary Confinement Care (DCC). Table 3 is a frequency distribution/

distribution derived from domiciliary midwives' time-sheets showing the time they spent on home deliveries. Taking the mean of this very wide distribution gives an ALOS of 5.33 hours, which is too short. However, this figure does not include the many hours that midwives spent on what is accredited to 'antenatal home visits'. As has been pointed out already, it has been necessary to include this activity with domiciliary confinement care. There was a total of 5849 antenatal home visits in 1968.

It is midwifery policy to visit each domiciliary booked mother at least twice before delivery. If each of these visits takes an average of  $51\frac{1}{2}$  minutes (see Table 4), then the 1397 domiciliary booked cases used  $1397 \times 2 \times 0.86 \approx 2402.84$  midwife hours. After allowing for these 2794 antenatal home visits, and also for 351 home visits made to early-discharge patients, there are 2704 visits which will be treated as confinement visits requiring 3.56 midwife hours each (Table 4)  $\approx 9626.24$  hours.

These two totals ( $2402.84 + 9626.24$ ) are summed, and then divided by the total number of domiciliary booked cases (1397), to give the average time of 8 hours 36 minutes that midwives spend on each domiciliary booked case pre-delivery. Adding in the time spent at delivery, midwives spend 13 hours 55 minutes providing confinement care.

On top of this, midwives also provide nursing care for the first/

first ten days post-delivery, and made 18594 such nursing visits to 1330 cases - implying that each case was visited, on average, almost 14 times. (This accords well with stated policy that a midwife calls twice daily for the first three days, and then only once a day for the following week). From discussions with the midwives, the average time spent on a nursing visit was 45 minutes, so the average time spent on nursing visits per domiciliary delivered case was  $13.98 \times 0.75 = 10.48$  hours, or 10 hours 29 minutes of midwife time.

The final estimate for the coefficient relating domiciliary midwife time (DMID) to domiciliary confinement care (DCC) is therefore equal to

$$10.48 + 13.94 = \underline{24.42 \text{ midwife hours.}}$$

(c) Hospital Early-Discharge Care (HEDC). Midwives paid 351 antenatal home visits to hospital early-discharge booked cases (i.e. one visit per case), each visit requiring 30 minutes of midwife time. They also made nine nursing visits, each visit taking approximately 45 minutes, so that each early-discharge case used  $0.5 + (0.75 \times 9)$  hours = 7 hours 15 minutes of domiciliary midwife time.

(d) Hospital Normal-Stay Care (HNSC). Similarly, domiciliary midwives paid two nursing visits to hospital normal-stay cases, so that each case used  $(0.75 \times 2)$  hours = 1 hour 30 minutes of midwife/

midwife time.

2. Domiciliary Clinics (DCL).

(a) Domiciliary Antenatal Care (DANC). There were nineteen clinic sessions per week in 1968, with an average running time of 2 hours 36 minutes. Allowing for public holidays, the total number of clinic hours was  $19 \times 51 \times 2.65 = 2567.85$  hours. This represents an average of  $\frac{2568}{11234} = 13\frac{1}{2}$  minutes (0.29 hours) of clinic time per attendance.

3. Domiciliary Health Visitors (DHV).

(a) Domiciliary Confinement Care (DCC). In 1968, health visitors made 1302 visits to expectant mothers, each visit lasting for approximately 30 minutes. This represents an average of 29 minutes (0.49 hours) per domiciliary confinement. However, since 1968, midwives have taken over this work, and consequently this resource (DHV) has been removed from the predictive use of the model.

4. Domiciliary Medical Outfits (DMO).

(a) Domiciliary Confinement Care (DCC). The 1968/69 financial year revised estimates of expenditure on maternity outfits was £1500, which implies an average cost of £1.13 per domiciliary confinement.

5. Drugs and Medical Requisites (DDG).

(a) Domiciliary Antenatal Care (DANC). The revised expenditure estimate on drugs and medical requisites for the domiciliary midwifery/

midwifery services was £1600, but this represents the budget estimate for both antenatal care and confinement care.

Investigation of the maternity hospital's out-patient costings shows a budget of £1292 for 24094 attendances (this includes postnatal attendances which are assumed to require the same as antenatal attendances) which implies an average cost of £0.05 per attendance. It is assumed that the average cost per attendance at the domiciliary clinics is the same as the average cost per attendance at the hospital clinic, £0.05 per attendance.

(b) Domiciliary Confinement Care (DCC). As each antenatal attendance used £0.05 of the total DDG budget, and there were 11234 attendances, the total antenatal budget must have been  $11234 \times 0.05 = \pounds 606$ , which leaves  $\pounds 1600 - \pounds 606 = \pounds 994$  for domiciliary confinement care. As there were 1330 domiciliary confinements, each case used, on average, £0.75.

6. Hospital Clinics (HCL).

(a) Hospital Antenatal Care - Out-patients (HANO). Antenatal care clinics were held on four afternoons per week, with an average running time of  $17\frac{1}{2}$  hours per week (Table 5). Allowing for public holidays, the total number of clinic hours for 1968 was  $17.5 \times 51 = 893$  hours. There were 20902 attenders, which represents an average of  $2\frac{1}{2}$  minutes (0.04 hours) of clinic time per attendance.

7. Hospital Midwives (HMID).

(a)/



(a) Hospital Antenatal Care - Out-Patients (HANO). Table 5 gives details of the number of hospital midwife hours used in providing out-patient antenatal care. Assuming a 51 week year, these 66 hours per week represent 3366 hours per year, or 9½ midwife minutes (0.16 hours) per attendance.

(b) Hospital In-Patient Care : See pp 141 ff.

8. Hospital Nurses (HNRS).

(a) Hospital Antenatal Care - Out-patients (HANO). Table 5 also gives the number of hours worked by nurses in providing out-patient antenatal care. The 20902 attendances required 893 hours of nurses time - an average of 2½ nursing minutes (0.04 hours) per attendance.

(b) Hospital In-Patient Care : As 7(b).

9. Hospital Clerks (HCLK).

Hospital Antenatal Care - Out-Patients (HANO). Clerical workers were required for 1237 hours in order to supervise arrivals and arrange subsequent visits. This is an average of 3½ clerical minutes (0.06 hours) per attendance.

10. Hospital Drugs and Dressings (HDD).

(a) Hospital Antenatal Care - Out-Patients (HANO). This has already been examined when deriving the coefficient relating domiciliary drugs and dressings to domiciliary antenatal care.

Total/

Total expenditure for the financial year 1968/69 was £1292, making an average expenditure of £0.05 per attendance (including postnatales).

(b) Hospital In-Patient Care : As 7(b).

Hospital In-Patient Care

Sunderland Maternity Hospital has a policy of allocating patients, where possible, to particular wards dependent upon their care requirements. As staffing varies according to these requirements, it is necessary to begin by investigating these ward variations. They can be summarised as follows:

Ward	Beds	Type of Care
Ward D	20	Antenatal
Ward A	20	Primarily postnatal
Ward B	20	
Ward C	14	
Ward F	24	
Labour Ward	1 Theatre	Primarily delivery
	( 1 Large Delivery Room	
4	( 3 Delivery Rooms	
	6 First Stage Rooms	

Ward/

<u>Ward D</u>	Total number of patient days	5912 (Table 6)
	Total number of bed days	7320 (20 x 365)
	Occupancy Rate	80.8%

In 1968, 364 antenatal care patients were discharged from Ward D with an average length of stay of 6.63 days (Table 7).

Allowing for these 2413 days leaves 3499 patient days to be accounted for by delivery cases receiving prenatal care. A 10% random sample of all deliveries suggested an average length of stay pre-delivery of approximately 1.55 days, which implies a total of 2257 pre-natal cases.

Labour Ward

Unfortunately, 1968 data relating to labour ward patient days was combined with data for Ward F. However, since March 1969 they have been separated, giving:

Month	Labour Ward	Ward F	Total	Labour Ward
1969	Patient Days	Patient Days		as % of Total
March	192	637	829	23.16
April	164	596	760	27.52
May	184	540	724	25.41
June	161	507	668	24.10
July	203	626	829	24.49
August	185	594	779	23.75
September	815	595	780	23.72
Total	1274	4095	5369	23.73

In/

In 1968 the combined patient-day total for the labour ward and ward F was 8571 patient days. Accepting the 23.73% of 1969 as a reliable guide to the proportion of the combined total that was attributable to the labour ward in 1968 gives 2034 patient days.

Table 7 shows that 43 antenatal care patients were discharged from the labour ward with an average length of stay of 1.56 days, which leaves 1967  $[2034 - (43 \times 1.56)]$  to be accounted for by deliveries.

On the assumption that all 2783 deliveries used the labour ward, the average length of stay in the ward per delivery was 17 hours (0.71 days).

Wards A, B, C and F

Table 6 shows the number of patient days per ward, and these are summarised:

Ward A 6095

Ward B 6030

Ward C 3364

Ward F 6537

---

TOTAL 22026 patient days

Table 7 shows that there were 84 antenatal care patients discharged from these wards with an average length of stay of 6.01 days, which leaves 21521 patient days.

Table/

Table 1 shows that there were 2804 lying-in patients with an average length of stay of 7.4 patient days, which leaves 816 patient days unaccounted for.

It is assumed that these are pre-delivery cases with an average length of stay of 1.55 days (see above), which implies 526 cases.

Of the 2804 lying-in cases, 21 were admitted as postnatal care patients, and will therefore be separated from the 2783 delivery cases.

Moreover, it is now convenient to divide lying-in cases into:  
351 early-discharge cases, with lying-in stay = 1.96 patient days.  
2313 normal-stay cases, with lying-in stay = 7.95 days.  
119 long-stay cases, with lying-in stay = 12.27 days.  
21 postnatal cases, with lying-in stay = 7.95 days.

Summarising these ward variations into a form adaptable to the model's activity specification gives:

Ward	Activity	Output	Average length of stay
D	{ HANI 1	364	6.63
	{ Pre-delivery	2257	1.55
	HANI/		

Ward	Activity	Output	Average length of stay
A	{ HANI 3	84	6.01
	{ Pre-delivery	526	1.55
B	{ HEDC	351	1.96
C	{ HNSC	2313	2783 deliveries
F	{ HLSC	119	
	{ HPNI	21	12.27
Labour	{ HANI 2	43	7.95
	{ Delivery	2783	1.56
			0.71

Non-Medical Staff

Table 8 shows the total number of day staff time spent on the three ward groupings. Pupil midwives are excluded because their level of supply is determined not so much by service (activity) requirements as by exogenous training programmes, which means that a linear relationship between the use of pupil midwives' time and the level of maternity service provision cannot be assumed.

Secondly, night staff had to be excluded as data was not available in a form that was adaptable to the requirements of the model's specification. This is not considered a serious omission as they are probably better viewed as a fixed overhead which does not vary to any significant effect during changes in output in the short and medium time period. It is assumed that the addition of a new/

new ward constitutes a long-term planning decision<sup>7</sup>.

Third, it is assumed that staff provide a level of care proportional to the number of patients in a ward during a day. As a simple example: if there are two nurses on duty for an eight hour day in a twenty bed ward of which only sixteen are occupied (i.e. an occupancy rate of 80%), then the amount of care provided to these sixteen patients is equal to  $\frac{2 \times 8}{16} = 1$  hour of care per patient per day. As already pointed out, this represents an average with deviations either way. 'Patient-days' were chosen as the measurement criteria because it seemed more realistic than the alternative of 'bed-days' - it was thought that staff were unlikely to devote much time to empty beds. (This is a subject that requires more detailed research - it may be that staff have to devote considerable amounts of time to preparing empty beds and their associated facilities).

Measuring staff utilization in units of hours per patient day may not be entirely satisfactory, but, short of detailed work study, it provides a workable compromise. Moreover, it does allow for one aspect of the quality of care. Returning to the example, if another nurse is brought into the ward and is assumed to provide care to the patients, then the level of care per patient increases from 1 nurse hour per patient day to  $1\frac{1}{2}$  nurse hours. From this, it may be concluded that there has been an increase in the quality of patient care, though empirical studies would be required to show whether/

whether, in fact, the nurse had been used to provide extra care.

It was not possible to measure any distinctive differences in the levels of care provided to different case types in particular wards, or group of wards. Thus the quantity of care provided per case is directly proportional to the average length of stay. (It is hoped that in maternity care this is not the serious source of error that it would be in general hospital care).

<u>Wards A, B, C and F</u>	Total number of patient days = 2202
	Total number of midwife hours = 17786
	Total number of nurse hours = 29278

From these, it can be calculated that midwives were required, on average, for  $48\frac{1}{2}$  minutes (0.81 hours) per patient per day.

Similarly, nurses were required for 1 hour  $19\frac{1}{2}$  minutes (1.33 hours) per patient per day.

<u>Ward D</u>	Total number of patient days = 5912
	Total number of midwife hours = 3906
	Total number of nurse hours = 1974

This means that midwives were required for 40 minutes (0.66 hours) per patient per day, and nurses for 20 minutes (0.33 hours) per patient per day.

Labour/



Labour Ward      Total number of patient days = 2034  
                         Total number of midwife hours = 12206  
                         Total number of nurse hours = 2840

Midwives were, therefore, required for almost 6 hours (5.97 hours) per patient per day, and nurses for 1 hour 23½ minutes (1.39 hours) per patient per day.

These staffing levels can now be summarised into the form of Matrix A (Table 9), and related to the seven in-patient care activities, Matrix B. Multiplying these two matrices together gives the resource coefficients for each in-patient care activity, Matrix C. For example, a normal-stay case (HNSC) uses, on average, 11 hours 41 minutes of midwives' time, and 12 hours 4 minutes of nurses' time.

10. Hospital Drugs and Dressings (HDD) /Continued/.

Hospital In-Patient Care.      It seemed reasonable to assume that an early-discharge case used less drugs and dressings than either normal-stay or long-stay cases. The coefficient for each category of in-patient care was, therefore, calculated by deriving the average cost of drugs and dressings per in-patient day, and then relating this to the average length of stay for each activity.

Total expenditure for the financial year 1968/69 = £10416

Total in-patient days for 1968 = 29972

Therefore the cost per in-patient day was £0.35. Table 10 gives/

gives the cost coefficients for each in-patient care activity.

11. Medical Staff (Paid by the Regional Hospital Board)

In order to analyse expenditure on the salaries of Senior Medical Staff, Newcastle Regional Hospital Board sends costing return forms to medical officers who are asked 'to use their experience in a sample four week period in order to give us (the R.H.B.) a suitable split of their salaries for the whole financial year. The return given should be for a normal period of work, disregarding any unusual feature such as sick leave, study leave or leave of medical colleagues'. These were summarised, in percentage form, as follows:

Grade	In-Patient	Operating Theatre	Out-Patient	Total
Consultants	31	25	23	79
Senior Registrar	31	7	19	57
Registrar	43	48	-	91

Assuming that the average number of hours worked per week by each member of these grades was 56 hours (which implies that 1% = 0.56 hours), the actual amounts of time spent on in-patients, out-patients and operating can be derived. It is further assumed that they worked a 48 week year.

Consultant Obstetricians (HCO).

(a)/

- (a) In-Patients:  $31\% \times 0.56 = 17.36$  hours per week  
= 833.28 hours per year.

The total number of in-patient days for wards A, B, C, D and F = 27938, so that the time spent on in-patients per patient per day was almost 2 minutes (0.03 hours).

- (b) Labour Ward:  $25\% \times 0.56 = 14.00$  hours per week  
= 672.00 hours per year.

The total number of in-patient days for the labour ward = 2034, so that time per patient per day was almost 20 minutes (0.33 hours).

- (c) Out-Patients:  $23\% \times 0.56 = 12.88$  hours per week  
= 618.24 hours per year.

The total number of out-patient attendances = 20902, so that time spent on out-patient per attendance was almost 2 minutes (0.03 hours).

Senior Registrars (HSR).

- (a) In-Patients:  $31\% \times 0.56 = 17.36$  hours per week  
= 833.28 hours per year.  
= 2 minutes (0.03 hours) per patient per day.

- (b) Labour Ward:  $7\% \times 0.56 = 3.92$  hours per week  
= 188.16 hours per year.  
=  $5\frac{1}{2}$  minutes (0.09 hours) per patient per day.

(c)/

- (c) Out-Patients:  $19\% \times 0.56 = 10.64$  hours per week  
= 501.72 hours per year.  
= 1 minute (0.02 hours) per attendance.

Registrars (HRO).

- (a) In-Patients:  $43\% \times 0.56 = 24.08$  hours per week  
= 1155.84 hours per year.  
=  $2\frac{1}{2}$  minutes (0.04 hours) per patient per day.
- (b) Labour Ward:  $48\% \times 0.56 = 26.88$  hours per week  
= 1290.24 hours per year.  
= 38 minutes (0.63 hours) per patient per day.

- (c) Out-Patients: Nil.

12. Senior House Officers (HSHO). /Paid by Hospital Management Committee/.

The hospital management committee does not require junior medical staff to complete returns in the same way as the regional hospital board requires of senior medical staff. However, the accountant was able to provide a break-down of expenditure on junior medical staff. On the assumption that the average salary paid to junior medical staff costs the hospital £0.69 per hour, the total hours worked by junior doctors must have been as follows:

Category/

Category	£	Hours
In-Patient	1502	2176.53
Theatre	270	391.40
Out-Patient	699	1013.06
TOTAL	2471	3580.99

(a) In-Patients: Total HSHO hours per year = 2176.53

Total in-patient days per year = 27938

Therefore, HSHOs were used for almost 5 minutes (0.08 hours) per patient per day.

(b) Labour Ward: Total HSHO hours per year = 391.4

Total patient days per year = 2034

Therefore, HSHOs were used for about one minute (0.02 hours) per patient per day.

(c) Out-Patients: Apart from providing care at antenatal clinics, an HSHO was also present at one postnatal clinic per week. Assuming a 51 week year to allow for public holidays, and an average clinic session of 4 hours, HSHOs spend approximately 204 hours per year on postnatals - which will, for the purposes of this model, be excluded.

Total HSHO hours per year = 1013

less 204

        
= 809

Therefore, each antenatal attender uses just over 2 minutes

(0.04/

(0.04 hours) of HSHOs time.

These medical staffing levels can now be summarised into Matrix A (Table 9) and multiplied with B to give the medical staff coefficients for each in-patient activity, Matrix C (Table 9).

13. Hospital Beds (HBED) and Hospital Labour Ward (HLW).

The coefficients relating both these resources to the in-patient care activities are readily identifiable from Matrix B (Table 9). The 'delivery' row gives the labour ward coefficients, whilst the hospital bed coefficients may be derived by summing the pre-delivery and lying-in rows - thus:

	HANI1	HANI2	HANI3	HEDC	HNSC	HLSC	HPNI
HBED	6.63	0.0	6.01	3.51	9.50	13.82	7.95
HLW	0.0	1.56	0.0	0.71	0.71	0.71	0.0

TABLE 1

Number of Lying-in Cases by Length of Stay. 1968.

Days	No. Cases	Cumulative Sum of Cases	%	Days x No. Cases	Cumulative Sum
1	13	13	0.5	13	13
2	338	351	12.5	676	689
3	318	669	23.9	954	1643
4	71	740	26.4	284	1927
5	49	789	28.1	245	2172
6	56	845	30.1	336	2508
7	133	978	34.9	931	3439
8	194	1172	41.8	1551	4991
9	876	2048	73.0	7884	12875
10	637	2685	95.8	6370	19245
11	71	2756	98.3	781	20026
12	22	2778	99.1	264	20290
13	12	2790	99.5	156	20446
14	4	2794		56	20502
15	1	2795		15	20517
16	-	2795		-	20517
17	-	2795		-	20517
18	1	2796		18	20535
19	3	2799		57	20592
20	-	2799		-	20592
21	2	2801		42	20634
22	1	2802		22	20656
23	1	2803		23	20679
24	-	2803		-	20679
25	-	2803		-	20679
26	1	2804	100.0	26	20705

Average length of stay = 7.4 lying-in days.

TABLE 2

'Frequency distribution of time spent by domiciliary midwives at antenatal clinics'.

[Sample month: December].

Hours (x)	f	fx
1	-	-
1½	1	1½
2	52	104
2½	22	55
3	34	102
3½	9	31½
4	13	52
4½	1	4½
5	-	-
	132	350½

MEAN = 2.65 hours

SD(x) = 0.68



TABLE 3

'Frequency distribution of time spent by domiciliary midwives on confinement visits'. [Sample months: July, November, December].

Hours (x)		f	fx
1	X	1	1
1½		-	-
2	XXXXXXXXXX	9	18
2½	XXXXXX	6	15
3	XXXXXXXXXXXXXXXXXXXX	17	51
3½	XXXXXXXXXXXXXXXXXXXX	22	77
4	XXXXXXXXXXXXXXXXXXXXXXXXXXXX	41	164
4½	XXXXXXXXXXXXXXXXXXXXXXXXXXXX	20	90
5	XXXXXXXXXXXXXXXXXXXXXXXXXXXX	36	180
5½	XXXXXXXXXX	10	55
6	XXXXXXXXXXXXXXXXXXXXXXXXXXXX	20	120
6½	XXXXXXXXXXXX	11	71½
7	XXXXXXXXXXXXXXXXXXXXXXXXXXXX	16	112
7½	XXXX	4	30
8	XXXXXXXXXX	8	64
8½	XXXXXXXXXX	7	59½
9	XXXXXX	5	45
9½	XXX	3	28½
10	X	1	10
10½	XXX	3	31½
11	X	1	11
11½	X	1	11½
12	XX	2	24
12½	X	1	12½
13		-	-
13½		-	-
14	X	1	14
•••			
20		-	-
20½	X	1	20½
		247	1316½

MEAN = 5.33 hours

SD(x) = 2.36

TABLE 4.

'Frequency distribution of time spent by domiciliary midwives on antenatal home visits'.  $\sqrt{\text{Sample month: December}}$ .

Hours (x)	f	fx
$\frac{1}{4}$	17	8.5
$\frac{3}{4}$	8	6.0
1	54	54.0
$\frac{1}{4}$	2	2.5
$\frac{1}{2}$	1	1.5
$\frac{3}{4}$	2	3.5
2	8	16.0
$2\frac{1}{4}$	-	-
$2\frac{1}{2}$	5	12.5
$2\frac{3}{4}$	-	-
3	6	18.0
$3\frac{1}{4}$	-	-
$3\frac{1}{2}$	3	10.5
$3\frac{3}{4}$	1	3.75
4	3	12.0
$4\frac{1}{4}$	-	-
$4\frac{1}{2}$	2	9.0
$4\frac{3}{4}$	-	-
5	5	25.0
$5\frac{1}{4}$	-	-
$5\frac{1}{2}$	3	16.5
$5\frac{3}{4}$	-	-
6	1	6.0
$6\frac{1}{4}$	-	-
...	-	-
$9\frac{1}{4}$	1	9.5
$9\frac{1}{2}$	-	-
$9\frac{3}{4}$	-	-
10	-	-
$10\frac{1}{4}$	-	-
$10\frac{1}{2}$	1	10.5
	44	156.75

MEAN = 0.86 hours.  
SD(x) = 0.21

MEAN = 3.56 hours  
SD(x) = 1.94

TABLE 5

'Staffing of Hospital Antenatal Clinic per week'.

CLINIC	MONDAY	WEDNESDAY	THURSDAY	FRIDAY	TOTAL
ALOC* (Hours)	4	4.5	4.5	4.5	17.5
No. Midwife Hours	12	18	18	18	66
No. Nurses Hours	4	4.5	4.5	4.5	17.5
No. Clerks Hours	4	6.75	6.75	6.75	24.25

\* : Average length of Clinic.

TABLE 6

Monthly Returns on Number of In-Patients. 1968.

	MOTHERS IN WARDS					TOTAL
	A	B	C	D	LW/F	
Jan.	682	555	3	513	662	2415
Feb.	632	507	16	415	593	2163
Mar.	488	503	343	490	706	2530
Apr.	449	485	312	480	690	2416
May	470	452	343	471	752	2488
Jun.	451	455	305	502	655	2368
July	518	558	310	600	793	2779
Aug.	506	552	381	578	821	2838
Sept.	453	461	332	483	724	2453
Oct.	490	502	347	494	763	2596
Nov.	426	470	308	390	625	2219
Dec.	530	530	364	496	787	2707
					8571	
					<del>2034</del>	
TOTAL	6095	6030	3364	5912	6537	29972

TABLE 7

Length of Stay of Antenatal Care Patients by Ward Discharged. 1968.

Days	WARD D		WARDS A, B, C, F		LABOUR WARD	
	No. Cases	Days x No. Cases	No. Cases	Days x No. Cases	No. Cases	Days x No. Cases
0	5	0	0	0	7	0
1	27	27	8	8	18	18
2	28	56	7	14	11	22
3	35	105	6	18	5	15
4	33	132	9	36	1	4
5	37	185	15	75		
6	40	240	7	42		
7	36	252	6	42		
8	26	208	5	40	1	8
9	25	225	7	63		
10	14	140	5	50		
11	23	253	2	22		
12	6	72	1	12		
13	4	52	3	39		
14	7	98	2	28		
15	3	45				
16	1	16	1	16		
17	1	17				
18	3	54				
19	4	76				
20	1	20				
22	1	22				
24	2	48				
27	1	27				
42	1	42				
	364	2412	84	505	43	67
	ALOS = 6.63		ALOS = 6.01		ALOS = 1.56	

TABLE 8

'Day-Staff at Sunderland Maternity Hospital by Wards'. (1968).

Wards A, B, C and F.

Grade	Weekly Hours +	Weeks Per Year =	Sub - Total (a) x	No. Staff =	Sub - Total (b)	Less HANO	TOTAL Hours	<u>SUM</u>
Sisters (FT)	42	46	1932	3	5796	-892	4904	} <u>17786</u> <u>hours</u>
Sisters (PT)	30	46	1382	2	2760		2760	
Staff								
Midwives (FT)	42	47	1974	5	9870	-688	9182	
Staff								} <u>29278</u> <u>hours</u>
Midwives (PT)	20	47	940	1	940		940	
Staff								} <u>29278</u> <u>hours</u>
Nurses (FT)	42	47	1974	3	5922		5922	
Staff								
Nurses (PT)	20	47	940	5	4700		4700	
SEN's (FT)	42	47	1974	4	7896	-204	7692	
SEN's (PT)	20	47	940	3	2820		2820	
N/Aux's (FT)	42	48	2016	2	4032	-688	3344	
N/Aux's (PT)	20	48	960	5	4800		4800	

Ward D

Grade	Weekly Hours	Weeks Per Year	Sub - Total (a)	No. Staff	Sub - Total (b)	Less HANO	TOTAL Hours	<u>SUM</u>
Sister (FT)	42	46	1932	1	1932		1932	} <u>3906</u> <u>hours</u>
Staff								
Midwife (FT)	42	47	1974	1	1974		1974	
SEN (FT)	42	47	1974	1	1974		1974	<u>1974</u> <u>hours</u>

Labour Ward./

TABLE 8

Labour Ward.

Grade	Weekly Hours	Weeks Per Year	Sub - Total (a)	No. Staff	Sub - Total (b)	Less HANO	TOTAL Hours	<u>SUM</u>
Dept. Sister	42	46	1932	1	1932		1932	} <u>12206</u> } <u>hours</u>
Sisters (FT)	42	46	1932	2	3864	-892	2972	
Sisters (PT)	30	46	1382	1	1380		1380	
Staff Midwives (FT)	42	47	1974	3	5922		5922	
Staff Nurses (PT)	20	47	940	1	940		940	} <u>2840</u> } <u>Hours</u>
SEN's (PT)	20	47	940	1	940		940	
N/Aux (PT)	20	48	960	1	960		960	

FT = Full Time

PT = Part Time

SEN = State Enrolled Nurse

N/Aux = Nursing Auxiliary.

TABLE 9

MATRIX A

Resource	Ward D Pre-Delivery	Labour Ward Delivery	Wards A, B, C & F Lying-In
HMLD	0.66	5.97	0.81
HNRS	0.33	1.39	1.33
HCO	0.03	0.33	0.03
HSR	0.03	0.09	0.03
HRO	0.04	0.63	0.04
SHO	0.08	0.19	0.08

MATRIX B

Activity	HANI 1	HANI 2	HANI 3	HEDC	HNSC	HLSC	HPNI
Pre-delivery	6.63	0.00	6.01	1.55	1.55	1.55	0.00
Delivery	0.00	1.56	0.00	0.71	0.71	0.71	0.00
Lying-in	0.00	0.00	0.00	1.96	7.95	12.27	7.95

MATRIX C

	HANI 1	HANI 2	HANI 3	HEDC	HNSC	HLSC	HPNI
HMLD	4.38	9.32	4.85	6.85	11.68	15.17	6.42
HNRS	2.21	2.17	7.99	4.11	12.07	17.81	10.56
HCO	0.20	0.51	0.18	0.34	0.52	0.65	0.24
HSR	0.20	0.14	0.18	0.17	0.35	0.48	0.24
HRO	0.27	0.98	0.25	0.59	0.84	1.01	0.33
SHO	0.52	0.30	0.47	0.41	0.88	1.21	0.62



TABLE 10

ACTIVITY	HANI 1	HANI 2	HANI 3	HEDC	HNSC	HLSC	HPNI
ALOS*	6.63	1.56	6.01	4.22	10.24	14.53	7.95
Cost per in-patient day	..	..	..	£0.35	..	..	..
Cost per Activity	2.30	0.54	2.08	1.46	3.54	5.04	2.76

\* : Average length of stay.

BIBLIOGRAPHY

- Ashford, J.R., Brindlecombe, F.S.W., and Fryer, J.G. (1968).  
'Birth Weight and Perinatal Mortality in England and Wales  
1956-1965' in G. McLachlan (ed.), Problems and Progress in  
Medical Care, Third Series, Nuffield Provincial Hospitals  
Trust: Oxford University Press.
- Ashford, J.R., and Fryer, J.G. (1970). 'Perinatal Mortality,  
Birth-Weight, and Place of Confinement 1956-1965' in  
G. McLachlan and R. Shegog (eds.), In The Beginning:  
Studies of Maternity Services. Nuffield Provincial  
Hospitals Trust: Oxford University Press.
- Ashley, D.J.B. (1968). 'Perinatal Mortality in Wales'.  
British Journal of Preventive and Social Medicine, 22,  
p. 132.
- Athurton, M.W., and Bamford, F.N. (1967). 'Paediatric Aspects  
of the Early Discharge of Maternity Patients'. British  
Medical Journal, iii, p. 517.
- Baligh, H.H., and Laughhunn, D.J. (1969). 'An Economic and  
Linear Model of the Hospital'. Health Services Research,  
Vol. 4, No. 4, p. 293.
- Brems, H. (1968). 'Quantitative Economic Theory. A Synthetic  
Approach'. New York: John Wiley & Sons, Inc.

British Medical Journal (1966). Editorial, p. 494.

Butler, N.R., and Bonham, D.G. (1963). Perinatal Mortality.

Edinburgh: E. and S. Livingstone.

Butterfield, W.J.H. (1968). Priorities In Medicine. Nuffield  
Provincial Hospitals Trust.

Culyer, A.J., Lavers, R.J., and Williams, A. (1971). Health  
Indicators, University of York. Forthcoming.

Craig, G.A., and Muirhead, J.M.B. (1967). 'Obstetric Aspects  
of the Early Discharge of Maternity Patients'. British  
Medical Journal, iii, p. 520.

Department of Health and Social Security (1969a). On the  
State of the Public Health. London: H.M.S.O.

Department of Health and Social Security (1969b). Report on  
Confidential Enquiries into Maternal Deaths in England and  
Wales 1964-1966. London: H.M.S.O.

Department of Health and Social Security (1970). Report of the  
Sub-Committee of the Standing Maternity and Midwifery  
Advisory Committee (Peel Report). London: H.M.S.O.

Feldstein, M.S. (1966). 'Measuring the Costs and Benefits of  
Health Services' in The Efficiency of Medical Care, Copenhagen,  
World Health Organization.

- Feldstein, M.S. (1967). *Economic Analysis for Health Service Efficiency*. Amsterdam: North Holland Publishing Company.
- Feldstein, M.A., and Butler, N.R. (1965). 'Analysis of Factors Affecting Perinatal Mortality'. *British Journal of Preventive and Social Medicine*, 19, p. 128.
- Golding, A.M.B. (1967). 'A New Maternity-Bed Ratio?' *Lancet*, i, p. 565.
- Hawgood, J., and Morley, R. (1969). *Evaluating the Benefits of University Libraries*, University of Durham.
- Hobbs, M.S.T., and Acheson, E.D. (1966). 'Perinatal Mortality and the organisation of Obstetric Services in the Oxford Area in 1962'. *British Medical Journal*, 1, p. 499.
- Hudson, C.K. (1968). 'Domiciliary Obstetrics in a Group Practice'. *Practitioner*, 201, p. 816.
- Law, R.G. (1967). *Standards of Obstetric Care*. Edinburgh: E. and S. Livingstone.
- McKinlay, J.B. (1969). 'Better Maternity Care for Whom . . .?' *Medical Officer*, 20, p. 275.
- McKinlay, J.B. (1970a). 'The New Late Comers for Antenatal Care'. *British Journal of Preventive and Social Medicine*, 24, p. 52.
- McKinlay/

McKinlay, J.B. (1970b). 'A Brief Description of a Study on the Utilisation of Maternity and Child Welfare Services by a Lower Working Class Subculture'. *Social Science and Medicine*, Vol. 4, p. 351.

Ministry of Health (1959). *Report of the Maternity Services Committee (Cranbrook Report)*, London: H.M.S.O.

Oldershaw, K.L., and Brudenall, J.M. (1968). 'The Use by General Practitioners of Obstetric Beds in a Consultant Unit: Report of First 500 Cases'. *British Medical Journal*, iii, p. 142.

Pinker, G.D., and Fraser, A.C. (1964). 'Early Discharge of Maternity Patients'. *British Medical Journal*, ii, p. 99.

Rawlings, E.E. (1969). 'General Practitioner and Obstetrician'. *Lancet*, i, p. 54.

Rawlings, E.E., Alwyn Smith, and Wiseberg, E. (1970). 'A General Practitioner Unit, Hope Hospital, Salford' in G. McLachlan and R. Shegog (eds.), *In The Beginning: Studies of Maternity Services*. Nuffield Provincial Hospitals Trust, Oxford University Press.

Reder, M.W. (1969). 'Some Problems in the Measurement of Productivity in the Medical Care Industry' in V.R. Fuchs (ed.), *Production/*

- Production and Productivity in the Service Industries,  
National Bureau of Economic Research, Volume 34, New York:  
Columbia University Press.
- Rhodes, P. (1968). 'General Practitioner Obstetric Beds in a  
Consultant Unit'. *British Medical Journal*, iv, p. 509.
- Richards, I.D.G., Donald, E.M., and Hamilton, F.M.W. (1970).  
'Use of Maternity Care in Glasgow' in G. McLachlan and  
R. Shegog (eds.), *In The Beginning: Studies of Maternity  
Services*. Nuffield Provincial Hospitals Trust: Oxford  
University Press.
- Robertson, J.S. (1970). Personal Communication.
- Robertson, J.S., and Carr, G. (1970). 'Late Bookers for Antenatal  
Care' in G. McLachlan and R. Shegog (eds.), *In The Beginning:  
Studies of Maternity Services*. Nuffield Provincial Hospitals  
Trust: Oxford University Press.
- Royal College of General Practitioners (1970). Present State  
and Future Needs of General Practice. Reports from General  
Practice: xii.
- Royal College of Obstetricians and Gynaecologists (1968).  
Hospital Obstetrics and the General Practitioner. London.
- Russell, J.K., et al. (1963). 'Maternity in Newcastle-upon-Tyne'.  
*Lancet*, i. p. 711.

Russell, J.K., and Miller, M.R. (1970). 'Family Responses to Early Discharge' in G. McLachlan and R. Shegog (eds.), In The Beginning: Studies of Maternity Services. Nuffield Provincial Hospitals Trust: Oxford University Press.

Schelling, T.C. (1965). 'The Life you Save may be your Own', in S.B. Chase (ed.), Problems in Public Expenditure Analysis, The Brookings Institution, Washington, D.C.

Shegog, R. (1966). 'The Future of the Maternity Services: A Suitable Case for Study' in G. McLachlan (ed.), Problems and Progress in Medical Care, Second Series, Nuffield Provincial Hospitals Trust: Oxford University Press.

Slugett, J., and Walker, S. (1956). 'A General Practitioner Maternity Unit'. Lancet, i, p. 684.

Topliss, E.P. (1970). 'Selection Procedure for Hospital and Domiciliary Confinements' in G. McLachlan and R. Shegog (eds.), In The Beginning: Studies of Maternity Services. Nuffield Provincial Hospitals Trust: Oxford University Press.

Vaughan, D.H. (1968). 'Some Social Factors in Perinatal Mortality'. British Journal of Preventive and Social Medicine, 22, p. 138.

World Health Organisation, Moscow Conference. Cited in Department of Health and Social Security (1970), paragraph 43.

Cmd. 9663

Report of the Committee of Inquiry into the Cost of the  
National Health Service (The Guillebaud Report). London:  
H.M.S.O., 1956.