

Studies on Identifying the End of the Milking Process in Dairy Cows

— Adaptability of Capacitive Proximity Sensor —

Michio KOMIYA,¹⁾ Kaori OHNO²⁾ and Katsumi KAWAKAMI³⁾

(June, 1994)

Introduction

In recent years, dairy farming has made efforts to decrease labor through developing automation system. However, milking routine depend on human power. The proportion of milking to annual working hours per milking cow in the burn reaches about 54%¹⁾.

The major labors in milking are attaching the teatcup to the teat of the cow and removing it. In the milking parlor, automatic cluster removal device (ACR) is in practical use in which electrodes measure electrical conductivity or a float detect reduction of milk-flow rate. There are reports on reduced sensor performance because of milk stones sticking at the chamber in float type or at electrodes in electrical conductivity type, and this results in overmilking and may cause a major loss through damage to the teat end and mastitis infection⁵⁾.

Mottram et al.⁶⁾ and Butler et al.²⁾ accurately calculated milk yield using software of ACR and they put into operation to reduce sensor malfunction. Ordloff⁷⁾ improved the float of the milk-flow meter and succeeded in eliminating the influence of froth in the chamber. In addition, a detecting method using ultrasound has been tested to improve a weak point in contact-type sensors whereby the sensor deteriorates depending on milk quality^{3,8,9)}.

In a previous report⁴⁾, a capacitive proximity sensor called the hose sensor that detects liquid presence in a vinyl hose was used and tried to measure flow rate reduction non-invasively. In the present report, we wish to report on the results of setting positions of the sensor and reactions of the sensor during milking.

Materials and Methods

To examine reactions under different sensor setting positions, a milking examination was done by a milking simulation using a milking pipeline system that can milk two cows at the same time in the laboratory. Sample solution for the milking simulation was 0.3% saline solution, almost the same electrical conductivity as straight milk (5.9 mS/cm), to use the alarm device detecting the end of the milking process (Orion Co., Ltd. : OEA-800-B).

1) 2) 酪農学科 (畜産システム工学) 小宮道士・大野かおり

Department of Dairy Science (Livestock Systems Engineering), Rakuno Gakuen University, Ebetsu, Hokkaido 069, Japan.

3) 酪農学科 (農業工学)

Department of Dairy Science (Agricultural Engineering), Rakuno Gakuen University, Ebetsu, Hokkaido 069, Japan

The sensor (Fujisawa Co., Ltd. : FSU-220) detects the liquid through the partition of resin hose or glass vessel, and is possible to use with a hose of outside diameter greater than 4 mm, thickness up to 16 mm. The possible liquid temperature is 0-100°C and temperature drift of detecting the liquid level less than ± 1.5 mm. The reaction of the sensor to the liquid could be converted to voltage (relay contact type, 12 V) from an exclusive amplifier. In this report, voltage data stored in a recorder (NEC Sanei Co., Ltd. : 7G01) as in the previous report. The alarm device detecting the end of the milking process measures milking time and reduction of the milk-flow rate by the installed electrodes of a device at a pipeline, measures electrical conductivity and notifies the operator with an LED and a buzzer sound. When the milk-flow rate gradually reduced in the final milking process, this warning is classified into three phases according to the milk-flow rate and is indicated.

Setting positions of the sensor were at five points (Fig. 1): three points (a, b, c) on the vertical part of a milk hose that was 300 mm under a tap (a height of 1880 mm) on the pipeline and two points (d, e) on the horizontal part of a milk hose that was 300 mm away from the milk claw. The height between the milk claw and the tap was 1260 mm, the length of the milk hose was 2600 mm, the bore was 15 mm, and the milking vacuum of the pipeline system was 44-47 kPa. The part to which the sensor was attached was changed with Teflon hosing that repels water, so that the water would not remain in the circumference of the sensor. When four teatcups were installed on the imitation teats of the milking experimental device, the measured values of the sensor and reactions of the alarm device were simultaneously begun to be recorded. The sample clock in that case was 80 msec, the number of data points were 2 kilo-words (2048), so the measurement time becomes 163.8

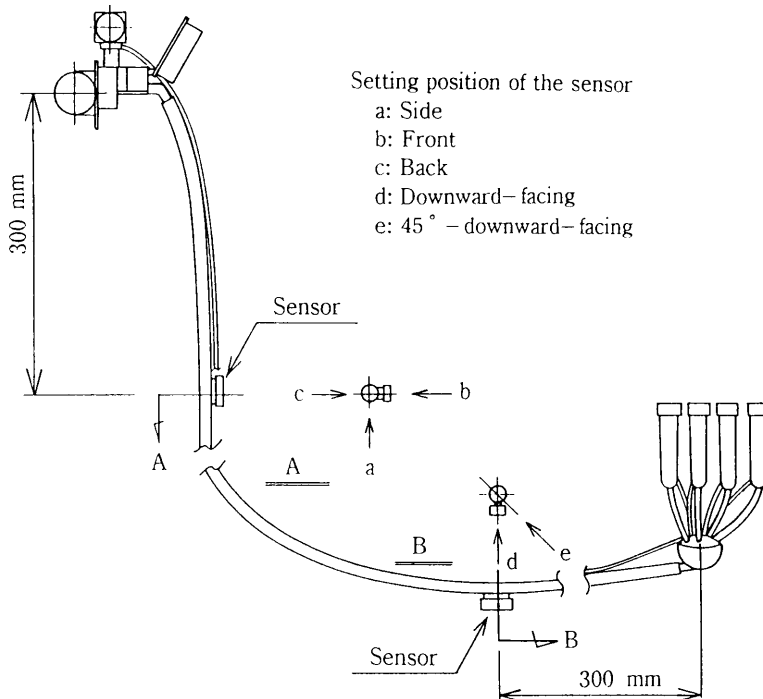

Fig. 1. Setting position of the sensor in the milking simulation.

sec. The quantity of water supplied to the imitation teat changed to six stages by adjusting the valve opening of the bucket and the flow was calculated from liquid weight after the measurement.

The milking examination was conducted to test the sensor adaptability using 14 milking cows during evening milking in the research farm. The capacity of the pipeline milker system (Orion Co., Ltd.: PMH-51S-C) was milking 8 cows at the same time, and 100 cows in a milking period. The maximum height of the tap was 1900 mm and the milking vacuum was 44-48 kPa.

Considering the influence of cow movement, the setting position of the sensor selected two points (Fig. 2; g, f) on the horizontal part of the milk hose between the milk-flow meter and the alarm device (Fig. 3). The attached part of the sensor was changed with Teflon hosing as the same manner as in the milking simulation.

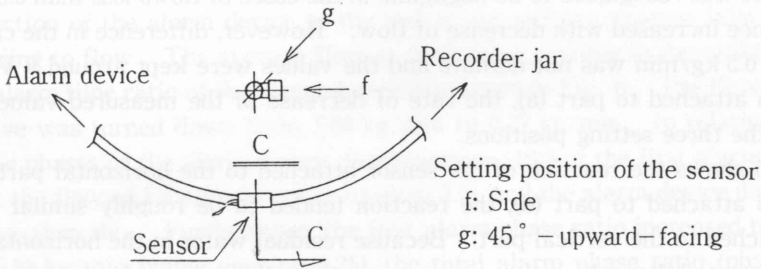

Fig. 2. Setting position of the sensor in the milking examination.

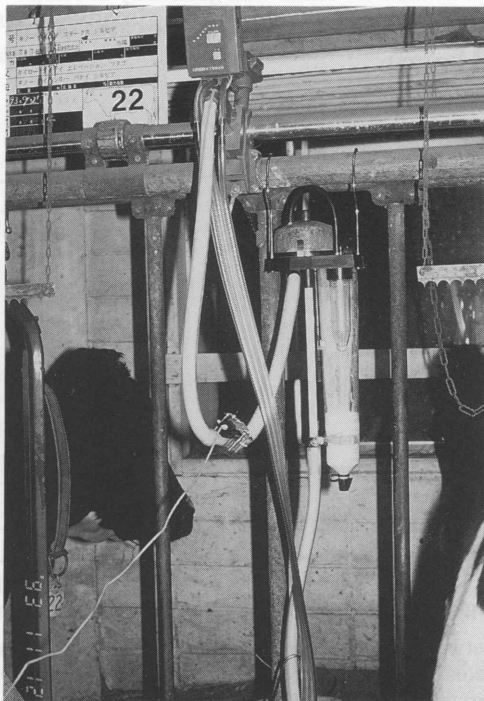

Fig. 3. Setting position (g): Upper the 45° direction.

A measurement continued from the time when teatcups were attached to the teats until the time they were removed. A sample clock was set to 200 msec to record all data in each milking process in the data points of 2 kilo-words. The data of measured values and reactions of the alarm device at the end of the milking process were recorded in the same manner as in the milking simulation. The milk yield of each cow was measured by the milk-flow meter (Orion CO., Ltd.: Milko Scope MKII).

Results and Discussion

1. Influence of setting positions of the sensor

Fig. 4 shows the relationship between the reaction of the sensor attached to the vertical part of the milk hose and the flow in the milking simulation. The measured value of the sensor was recognized to have the tendency decreasing gradually at a flow below 0.5 kg/min. The difference reaction depending on setting position of the sensor on the vertical part was recognized to be negligible in the cases of flows less than 0.5 kg/min, but the difference increased with decrease of flow. However, difference in the cases of flows more than 0.5 kg/min was not definite and the values were kept around 9 V. When the sensor was attached to part (a), the rate of decrease of the measured value became the largest in the three setting positions.

Fig. 5 shows the reaction of the sensor attached to the horizontal part. When the sensor was attached to part (d), the reaction tended to be roughly similar to when the sensor attached to the vertical part. Because residual water in the horizontal part of the hose was detected throughout the measurement time, the measured values were kept to the standard voltage of 12 V. When the sensor was attached to part (e), because the sensor reacted intermittently, the measured value was generally around 7-9 V in the cases of flows more than 1.2 kg/min, and decreasing gradually in the cases of less flow than this level, and finally showed 0 V at 0.4 kg/min.

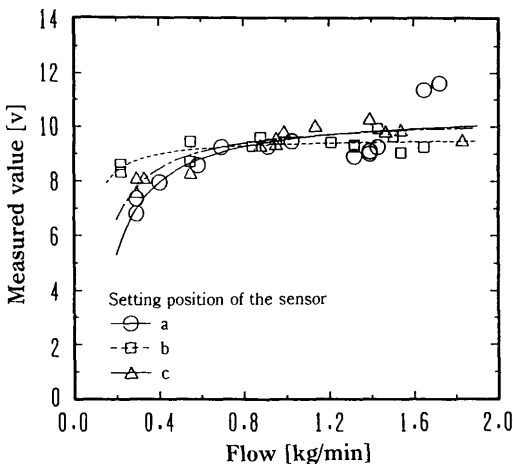

Fig. 4. The relationship between the flow and the measured value of the sensor attached to the vertical part of the milk hose (milking simulation).

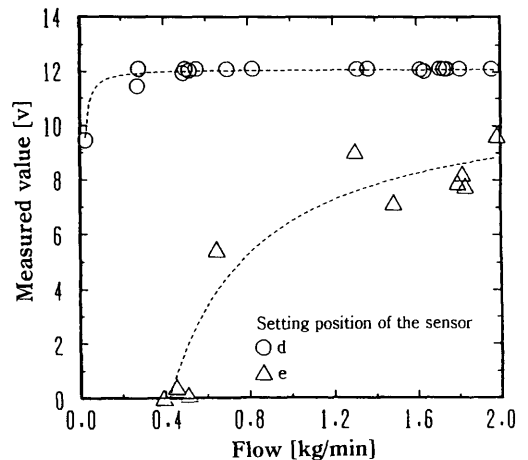

Fig. 5. The relationship between the flow and the measured value of the sensor attached to the horizontal part of the milk hose (milking simulation).

Some differences were recognized by the course of the stream in the vertical part of the milk hose. But the sensor has to judge precisely by measured value the point at which teatcups should be removed at the milk-flow rate below 0.5 kg/min. Therefore it is considered that a basic requirement for setting the position of the sensor is having a large difference of measured value between 1.0 kg/min and 0.5 kg/min. The voltage difference was only 1-2 V at part (a), where the difference becomes largest on the vertical part. Therefore, it seems to be difficult to obtain stable reactions of the sensor as the current in the hose varies continuously. When the sensor was attached to part (e) at the horizontal part, the measured value showed 0 V at the flow of 0.5 kg/min and there was enough voltage difference to detect decrease of flow from 1.0 to 0.5 kg/min. As the maximum milk-flow rate during practical milking became 4-6 kg/min, i. e. 2-3 times higher flow than that in the milking simulation, it is assumed that the suitable position of the sensor is the side or more upward side of the horizontal part of the hose.

2. Flow and alarm phase

The reaction of the alarm device at the end of the milking process falls into three phases according to flow. The average flow at each valve opening in the milking simulation and the alarm time ratio of the alarm device are shown in Fig. 6. The flow decreased when the valve was turned down from 1.66 kg/min to 0.27 kg/min. In relation between flow and three phases of the alarm device, few reactions (4%) of the first alarm phase are recognized at the flow of 1.2 kg/min (valve opening 0.5), and the alarm device did not react at greater flow than this. Furthermore, the first alarm phase ratio increased to 15.2% at the flow of 0.88 kg/min (valve opening 0.25), the total alarm phase ratio (phase 1 to 3) occupied 74.6% at the flow of 0.49 kg/min (valve opening 0.188), and the third-alarm phase ratio occupied 72.2% at the flow of 0.27 kg/min (valve opening 0.125). As previous study⁴⁾, when the flow became approximately 1.0 kg/min, warning began by the alarm device and the final third-alarm phase was shown to occur below the flow of 0.4 kg/min in the present study.

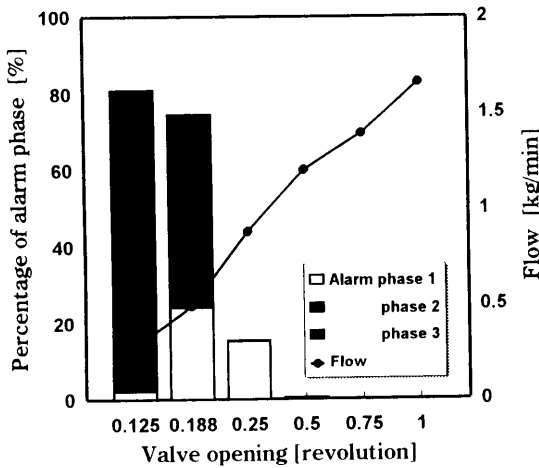

Fig. 6. The average flow and the alarm time ratio of the alarm device at the end of the milking process.

3. Reaction of the sensor during milking

Figure 7 and 8 show measured value and reaction example of the alarm device when the sensor was attached to parts (f) and (g) at the horizontal part of the milk hose in the milking examination. Measured values showed 25 data points averaging five seconds. When the sensor was attached to part (f), the measured value was shown uniformly to be 12 V from the first period of milking to the first half of the latter period so that flows were much more than in the milking simulation (Fig. 7). Because of raw milk remaining behind in the horizontal part of the hose, it was considered that the measured value showed 12 V at the end of milking. But when the sensor was attached to part (g), the measured value decreased temporarily to 3-5 V in the mid-period of milking too (Fig. 8). Thus, to detect accurately the increase and decrease of milk-flow rate during milking, it seems to be appropriate to attach the sensor to part (g) and decrease the sensitivity.

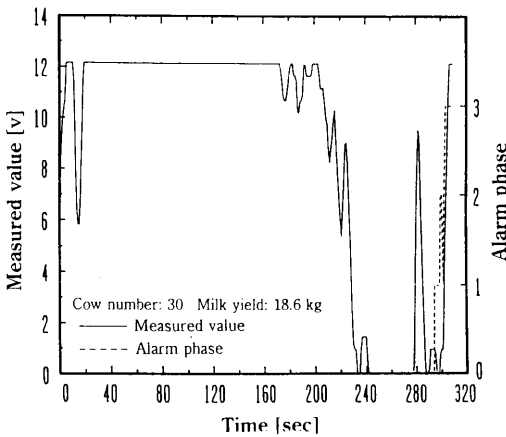

Fig. 7. A reaction example of the alarm device and the measured value of the sensor attached to the side of the horizontal part (milking examination).

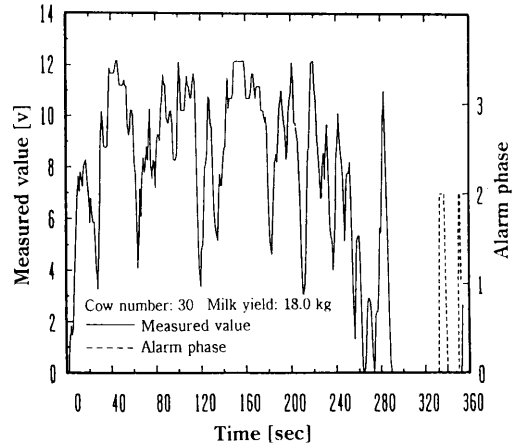

Fig. 8. A reaction example of the alarm device and the measured value of the sensor attached to the 45°-upward-facing direction of the horizontal part.

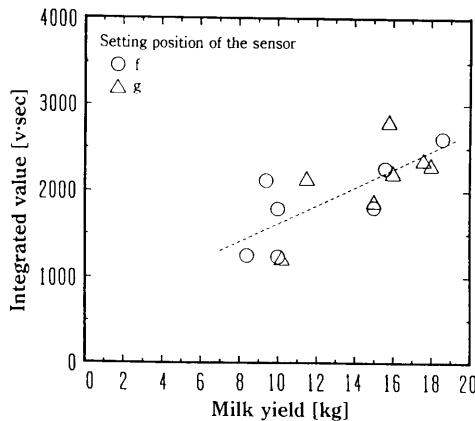

Fig. 9. Relation of the integral calculus value and the milk yield.

Figure 9 shows the relation between individual milk yield and integral calculus value which integrate the measured value of the sensor at both setting positions. Equilateral correlation ($r=0.754$) was observed between milk yield and integral calculus value, however it was not reasonable to obtain milk yield from the integral calculus value. There was no difference between the setting positions. The difference of measured value shown in Figs. 7 and 8 caused by the setting positions was important to the purpose of this experiment for detecting the end of milking accurately by suspension of the milk-flow rather than calculating milk yield.

By investigating minutely the relation between the milk-flow rate and the measured value during milking and detecting the existence and quantity of the milk-flow accurately, we think in the future to add functions not only detecting the end of milking but also milk yield measurement.

Summary

In order to detect the end of the milking process non-invasively, an electrical capacitance sensor was attached the different part of milk hose, reactions of the sensor were tested with saline solution in laboratory and during milking in the barn. The results are as follows:

1. When the sensor was attached to the part of 45° -downward- facing direction on the horizontal part of the milk hose in the milking simulation, the measured value changed 0-9 V with a flow rate change of 0.4-2.0 kg/min.

2. In the milking simulation, the first alarm phase ratio became 15.2% at the flow of 0.88 kg/min. Total alarm phase ratio (phase 1 to 3) occupied 74.6% at the flow of 0.49 kg/min, and the third-alarm phase ratio occupied 72.2% at the flow of 0.27 kg/min.

3. In the milking examination, when the sensor was attached facing sideways on the hose, the measured value of the sensor kept maximum 12 V. But when the sensor was attached to the part of 45° -upward- facing direction, the measured value decreased temporarily to 3-5 V. Positive correlation ($r=0.754$) was observed between milk yield and integral calculus value which integrated the measured value of the sensor.

References

- 1) Agricultural statistic Hokkaido branch office, 1991: Agricultural statistic annual report in Hokkaido. Part of agricultural and livestock production costs and agricultural prices. : 52-57.
- 2) Butler, M. C., C. J. Allen and J. E. Hillerton, 1990: Methods of measuring and calculating milking performance of cows. *J. Agric. Engng. Res.*, **46**: 245-257.
- 3) Delwiche, M. J., N. R. Scott and C. J. Drost, 1980: Ultrasonic measurement of teat milk flow. *TRANSACTIONS of the A. S. A. E.*, **23**: 746-752.
- 4) Komiya, M. and K. Kawakami, 1993: Studies on identifying the end of each milking period in dairy cows. A performance comparison of the hose sensor and the alarm device at the end of the milking period. *J. Hokkaido Branch Jpn. Soc. Agric. Machinery*, **34**: 5-9.
- 5) Lowe, F. R., 1981: Some basic facts about a milking machine. In *Milking Machines*, pp. 1-11, Pergamon Press, Oxford.
- 6) Mottram, T. T., D. L. O. Smith and R. J. Godwin, 1991: Development of an improved automatic cluster removal system for dairy animals. *J. Agric. Engng. Res.*, **49**: 73-84.
- 7) Ordolff, D., 1989: Investigations on the design of floats to control milk meters. *J. Agric.*

Engng. Res., **43**: 113-123.

- 8) Thompson, P.D. and L. E. Campbell, 1974: Monitoring the flow of milk within machine milked teat by observing doppler shift of back-scattered ultrasound. TRANSACTIONS of the A. S. A. E., **17**: 496-499.
- 9) Williams, D. M. and G. A. Mein, 1986: The bovine teat canal: Information from measurement of velocity of milk flow from the teat. J. Dairy Res., **53**: 179-185.

要 約

本研究は、搾乳の終了を非接触で検出するために、差動型静電センサをミルクホースの異なる位置に取り付け、食塩水による模擬搾乳試験と実搾乳試験を実施しセンサの反応を試験した。実験結果を要約すると以下の通りである。

1. 模擬搾乳試験においてセンサをミルクホース水平部分の下45度に取り付けた場合、センサ計測値は流量0.4~2.0 kg/minの変化に伴い0~9 Vに変化した。
2. 模擬搾乳試験において、警報1段階の時間割合が流量0.88 kg/minでは15.2%に、流量0.49 kg/minでは警報1~3段階が全体の74.6%を占め、さらに流量0.27 kg/minでは警報3段階の反応だけで72.2%になった。
3. 実搾乳試験では、センサをミルクホースの側面に取り付けた場合、センサ計測値は一様に12 Vを示した。しかし、上45度に取り付けた場合は一時的に計測値が3~5 Vまで減少した。また、計測値を積分したセンサ積分値と乳量の間には正の相関($r=0.754$)が認められた。