

RPSEP-24

THE EFFECT OF INFORMATION SYSTEM QUALITY, PERCEIVED USEFULNESS AND INFORMATION QUALITY TO END USERS' SATISFACTION OF ACCOUNTING DRY LAB PROGRAM AT OPEN UNIVERSITY OF INDONESIA

Irma¹, Rini Dwiyani Hadiwidjaja²

^{1,2} Universitas Terbuka
¹irma@ut.ac.id, ²rini@ut.ac.id

Abstract

In implementing distance education, Universitas Terbuka (UT) utilizes numerous learning materials. Utilization of technology into the learning process also becomes a priority in implementing distance education at UT that can help learners to study independently. One of the most important aspects in UT's Accounting Department is the compliance of practicum subjects in a distance learning system. This becomes a challenge for Accounting Department to carry out the practicum in the distance learning system. Accounting Department of UT has developed system that delivering accounting course in a distance education to carry out the practicum. It's called Accounting Dry Lab Program (ADLP). ADLP is accounting practice with interactive computer-aided with interesting animation, images, audio and video to deliver the knowledge from teachers to the students. In addition, ADLP can be accessed via UT's website and facilitate students in understanding the knowledge.

The purpose of this study is to evaluate implementation of ADLP by looking at users' perceptions of the system quality and information quality, associated with the perceived usefulness and the satisfaction of user through Structural Equation Modeling (SEM). Respondents in this study were active college students in UT's accounting department at the registration period of 2014. The results of this study show that information system quality statistically significant affects the perceived of usefulness and end-user accounting software satisfaction. Information quality statistically significant affects the perceived usefulness and end-user accounting software satisfaction. Perceived usefulness affects the end-user accounting software satisfaction.

Keywords: accounting dry lab program, end user satisfaction, information system quality, information quality, perceived of usefulness.

1. Introduction

In 2010 UT's Accounting department launches a practicum program that seeks to cover the weaknesses experienced by students in the Online Tutorial (Tuton). Tuton has not been able to satisfy and meet the needs and objectives of practicum. Students should continue to monitor the initiation of material every week, and should be active in the discussion forum.

Besides interaction with tutors or lecturers every week should be exists. If students miss the learning process within a week, it will not be able to repeat in the next week. In general, Tuton can achieve cognitive objectives of the course Introduction to Accounting Laboratory, but it can't be used to improve student skills in working on accounting cases as in real business practices.

Though the end goal of accounting practicum is improving students skills to resolve the case of accounting transactions to the preparation of financial statements in various cases and industry. This skills will appear on the student's ability to resolve the case of accounting on the final exams. When students are not skilled, though diligent in following Tuton, surely will not be able to resolve the case of accounting in the final exam because they're not accustomed to practicing accountancy. That's why UT's Accounting Department makes a practicum program called Dry Lab for accounting introduction course.

Dry lab is an abbreviation of Dry Laboratorium which is a lab with simulated via computer and equipped with animation, images, audio, and video that developed to allow students to carry out practical work with easy, fun and effective and efficient. To assist students in conducting lab, UT's Accounting Department provide a theoretical basis or introductory on accounting concepts before students do the lab working. These concepts being contained in the Dry Lab Introduction to Accounting module which is expected students will not have difficulty in understanding the subject.

Dry Lab can be accessed easily via UT's website, without the constraints of time and place. In addition through the UT website, under certain circumstances dry lab program can also be obtained by the student in the form of a compact disc and the practicum results can be sent to either UT Accounting Department through the Internet (softcopy) or via mail (hardcopy). The two main requirements to be able to follow the drylab program is: 1). You have to be registered as a student lab course Introduction to Accounting and 2). having basic computer skills such as excel programs, word, and simple navigation computer operation.

Dry Lab program has been launched, but until now the evaluation of the quality of information and quality of information systems that affect the perception of usefulness and user satisfaction levels itself has not been much done at the Open University. Meanwhile, according to Janson and Subramanian (1996) and Lucas et al. (1998), stated that the problem that usually occurs in the use of accounting drylab package is system incompatibility with the

information required by the end user. The discrepancy between the needs of the students drylab applications as users could pose a significant problem for them. Technical difficulties which interfere in drylab, interfacing problems in the system, and difficulty in hardware can make a lower levels of satisfaction.

If students are not satisfied with the drylab program, they will no longer use it. EUCS (End User Computer Satisfaction) can be used as a signal for the Open University in general and specially for Accounting Department to overcome these difficulties and mismatches. Seddon (1997) stated that by overcoming the weaknesses of the better measurement, end-user satisfaction can be used to measure the gain or success of Dry Lab.

Departed from the reasoning and the empirical facts, this study try to evaluate the application of drylab program. The evaluation is done by looking at students' perceptions of the quality of information and quality of existing information systems in the Dry Lab, associated with the perceived usefulness and the level of student satisfaction over the Dry Lab through structural equation modeling. The use of this model is important because it is a powerful way to overcome the problems that arise in information systems research and understanding of emergence.

If the student does not accept or use the system effectively, the benefit of the Dry Lab as a learning system based on e-learning can not be realized. It is therefore important to investigate the factors and critical success drivers of Dry Lab to provide feedback to designers and teachers to build systems that are useful and accepted by the end user, in this case the student of UT's accounting department. Departed from this facts and the background research, the formulation of the problem in this study are: 1). how the influence of the quality of the information system and the quality of information on user satisfaction Dry Lab, 2).how the variables influence perceived usefulness as an intervening variable in the relationship between the quality of information and quality of information system on end-user satisfaction of Dry Lab, 3). how the structure and dimensionality, reliability and validity of the instrument used to measure end-user computing satisfaction (EUCS) made by Doll and Torkzadeh (1988). This study is also the response of Klenke's research (1992) which stated the need for cross-validation MIS instruments and to re-examine the instrument EUCS with new data.

Meanwhile the objective to be achieved in this study are: 1). To investigate the influence of the quality of the information system and the quality of information on end-user

satisfaction drylab program, 2). To examine the effect of perceived usefulness as an intervening variable in the relationship between the quality of information systems and information quality and end user satisfaction drylab introductory accounting, 3). To examine the structure and dimensionality, reliability and validity of the instrument used to measure end-user computing satisfaction (EUCS).

Hopefully this study can achieve the benefits to: 1). Those researchers and practitioners of information systems based learning (e-learning) in assessing the quality of cleaning lab to improve student satisfaction, 2). UT to develop innovations that fit the students need in the future and improvement of the dry lab quality, 3). UT's students in order to create an ideal network-based lab.

Information Systems

According to O'Brien (2006), information system is a combination of people, hardware, software, communication networks and data resources that collect, transform, and provide information in an organization. According Mutyarini and Sembiring (2006), the characteristics of information systems in higher education are as follows:

1. As a supporter of higher education institutions to achieve its objectives.
2. Having a purpose to:
 - a. Provide the necessary services to the satisfaction of the academic community, reliable and affordable.
 - b. Improving the quality of service in accordance with the mission of higher education.
 - c. Providing accurate information into and out of institutions.
3. Consists of units of information systems that stand alone but in line with the vision and mission of the institution.
4. Accessed by various academics communities with the needs, roles and different knowledge.

The role of computer-based information systems has expanded significantly over the past few years. The widespread development of information systems also brings a change in the role of the information system itself. Any changes have an impact on end users and managers in an organization. As an example of an information system among others:

1. Academic Information System (AIS)-based Web. The purpose of making the Academic Information System (AIS) is to support education, so that the college can provide better information and effective to the community, both within and outside the university through the Internet. Major features of Academic Information Systems (AIS) web based, among

others: the curriculum of the course, the semester KRS registration, registration KRS short term, study sheets, profiles of faculty, staff profiles, job descriptions faculty, student profiles, profiles of alumni, student enrollment new, structurally faculty, databases thesis / final project, E-learning, academic calendars, announcements, event organizer, online quizzes, news, articles, and online photo gallery.

2. Library Information System (SIP) Web-based.

SIP Web-based can be used by various groups, both libraries at educational institutions and public libraries public or private. These applications and services facilitate access to information and library data, such as makes it easy to book / catalog, system membership, journal information, course material, borrow and return books and periodic reporting. Thus, the efficiency will be obtained in the work of the library staff library book management, presentation of information more easily and interactive, providing better services to the users of library services. The main features of the library information system (SIP)-based web include:

- a. Catalog / book category, the program can divide the book / paper or other products to be displayed at the library information system in separate categories, making it easier for users to find what they need.
- b. Detailed information books, complete information on the book / product, will be displayed screenshots (pictures) of the book (if any), equipped with a library ID, title of book, name of author, publisher, ISBN, number of pages of the book, the size, the type of language, source books, stock books available as well as a brief resume of the book / product.
- c. Forms of borrowing, visitors can make a request to borrow this book, where after selecting the desired book they will be asked to fill out a request form of borrowing.

Previous Research and Hypothesis Development

A. Information System Quality and End-User Satisfaction of information system

Information System Quality and End-User Satisfaction of information system is an inherent characteristic of the system itself (DeLone and McLean (1992). Defined quality system also Davis et al., (1989) and Chin and Todd (1995) as perceived ease of use that is how big the perceived computer technology is relatively easy to understand and use. Perceived usefulness is defined as the degree to which a person believes that using a particular system can improve

the performance (Davis, 1989). Research Adams et al. (1992), showed a positive relationship between the usefulness and ease of use. Iqbaria, Guimaraes, and Davis (1995) in their study using the technology acceptance model (TAM) showed the influence of perceived ease of use on perceived usefulness. Test results Mao and Palvia (2006), as well as Simon and Paper (2007), shows the influence of perceived ease of use on perceived usefulness.

Seddon (1997) conducted a study to see the relationship between the perceived usefulness of information quality. The results of the study Seddon (1997) on the relationship between these two variables, the results of research supported by Li (1997) and Rai et al., (2002). If the user is confident with the quality of drylab accounting system it uses, and feel that the system is not difficult, then they will believe that the use of such a system would provide greater benefits and will improve their performance. If the information generated from the accounting drylab used increasingly accurate, timely, and has good reliability, the more it will increase the confidence of users of the system. Increased user confidence in information systems, is expected to further improve their performance.

Based on the above description of this study hypothesized that based on the perception of the user, the higher the quality of accounting drylab, will further increase the perceived usefulness. A second hypothesis is built higher quality accounting information produced Software used, will further enhance user perceived usefulness, in terms of its perception.

H1: The quality of information systems a positive effect on Perceived Usefulness.

H2: Information quality positive effect on Perceived Usefulness.

B. The quality of information systems, information quality and user satisfaction of information system.

Size of user satisfaction in a computer system is reflected by the quality system owned (Guimaraes et al, 1992; Yoon et al, 1995). User satisfaction of an information system is how users view information in a real system, not on the quality of the engineering system (Guimaraes et al, 2003). In the research literature and in practice, user satisfaction is often used as a surrogate measure of the effectiveness of information system (Melone, 1990). The results obtained DeLone and McLean (1992), McKiney et al., (2002), Rai et al., (2002), and Livari (2005) indicates that the quality of the information system has positive influence on the wearer satisfaction.

The higher the quality of information produced by an information system, will further enhance user satisfaction (DeLone and McLean, 1992). This opinion is supported by the

results of McKiney et al., (2002), Rai et al., (2002), and Livari (2005). If users believe that the quality of information systems and quality system information generated from the system used is good, they will be satisfied using the system.

This study hypothesized the third hypothesis that higher quality accounting introduction drylab used, will increase user satisfaction according to their perception. For the fourth hypothesis in this study is the higher quality of information produced by the introduction of accounting used drylab will increase user satisfaction based on their perceptions.

H3: The quality of information systems a positive effect on user satisfaction of information system.

H4: The quality of information has a positive effect on user satisfaction of information system.

C. Perceived Usefulness and User Satisfaction

DeLone and McLean Information System (1992), states that the impact of the use of information systems on the performance of the individual to the level of user satisfaction (user satisfaction) have a reciprocal relationship. While Seddon (1997) in his model hypothesizes that the impact of the use of information systems in the form of increasing the performance of the individual, will affect the level of user satisfaction.

Rai et al., (2002) examined the relationship between perceived usefulness to the user satisfaction using three models of information systems success. All three models are models of information systems success DeLone and McLean (1992), the model Seddon (1997), and Model Seddon (1997) modified by adding the relationship between perceived usefulness with system use. Research results indicate overall perceived usefulness affect user satisfaction. Livari (2005), conduct research on the success of the new information system is applied to the users of information systems in an organization which is mandatory. Research results for perceived usefulness variable relationship with user satisfaction shows the influence of both variables. If users feel the benefits of the information system of systems that are used, then they will be satisfied using the system.

Based on the above description of this study hypothesized that the higher the perceived usefulness, user satisfaction will increase drylab accounting, according to their perception.

H5: Perceived Usefulness has a positive effect on user satisfaction of information system.

Thought and the hypothesis can be stated in the following research framework.

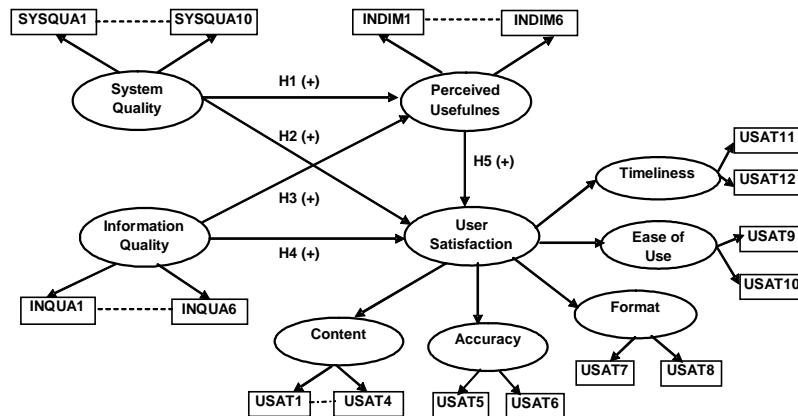

Figure 1. Modified Model of DeLone and McLean (1992) and Seddon (1992, 1997)

Methods and Techniques of Data Collection

This study uses primary data that is obtained directly from the original sources (Sekaran, 2003). The unit of analysis of this study is all respondents who use drylab introductory accounting at UT's Accounting Department. The data was collected through a questionnaire and sent to the students of UT's Accounting Department. Before being sent to the respondents, we conducted a pretest on the questionnaire in advance, to ensure that the sentences in the questionnaire can be correctly understood by the respondents. After the pretest, the questionnaire is sent directly to the student via e-mail and online tutorial. Questionnaires were sent, along with a cover letter containing instructions and explanations charging research purposes. This sample selection method is purposive sampling and based on certain criteria (Sekaran, 2003). Criteria for the selection of the sample respondents are students who register and use drylab program at least since 2011 to 2014. The size of the sample is determined by the number of respondents who return the questionnaire. The study period is the period of deployment to the collection of questionnaires from respondents that during the four months from February 2014 until April 2014.

Research Model

This research uses a model form of Structural Equation Model and uses a modified model of information system success model of DeLone and McLean (1992) and Seddon (1997), by adding a confirmatory factor analysis (CFA) for latent variables user satisfaction. The addition of this model is expected to give a better explanation on the validity and reliability of each instrument in EUCS. The addition of this model is also based on research results Somers, Nelson, and Karimi (2000).

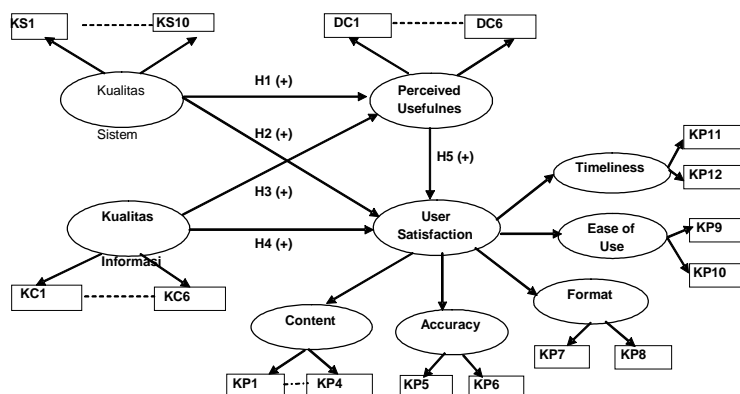

Figure 2. Research Model

Latent Variable

Operationalization of the latent variables are the key variables that are the focus of attention in this study. This variable is an abstract concept that can only be observed indirectly and imperfectly through its effect on the observed variables (Wijanto, 2006). There are 6 Latent variables in this study which consists of:

Information System Quality.

The quality of information systems referred to in this study is the quality of accounting drylab used, seen from the user perception. The items to measure these variables adopted from the questionnaire used by McGill et al. (2003). The items are an adaptation of the questionnaire Davis et al, (1988). The quality of information systems in the path diagram abbreviated as KS. This variable was measured by 10 questions with 5 Likert scale from very disagree to very agree. The higher the score of this variable, meaning the higher the accounting drylab quality as perceived by the user. The lower the score of this variable, indicating that lower the accounting drylab quality as perceived by the user.

Information Quality

Information Quality referred to user's perception of the quality produced by the accounting drylab used. Some karakteristik used to assess the quality of accounting drylab of these include the accuracy, timeliness, relevance, informativeness, and Competitiveness (Weber, 1999). The questionnaire used to measure the quality of this information in the adoption of the questionnaires used in the study of McGill et al., (2003). In the path diagrams,

quality of the information is abbreviated as KS. This variable was measured with 5 Likert scale from very disagree to very agree. The higher the score this variable, meaning the quality of accounting information generated drylab higher perceived by the user. The lower the score of this variable, indicating that the quality of accounting information produced drylab lower perceived by the user.

Perceived of Usefulness

In this study, perceived of usefulness variable is the user's perception of the extent to which the impact of the use of accounting drylab which may be influential in the increase their performance later. The instrument used to measure these variables are taken from Davis et al, (1988), with modifications of accounting drylab using. This questionnaire has also been used in research Sandee (1984) and Goodhue (1995). In the path diagram of this study, the perceived of usefulness variable abbreviated as DS. This variable was measured by 6 questions in 5 Likert scale from very disagree to very agree. The higher the score this variable, meaning the impact of the use of accounting drylab in improving user performance as perceived by the user is getting higher. The lower the score of this variable, indicating that the impact of the use of accounting drylab user performance as perceived by the user is getting lower.

User satisfaction

User Satisfaction in the study is the level of user satisfaction of using drylab accounting and outputs produced by the drylab. Weber (1999) states that there are five characteristics to assess user satisfaction is the content, accuracy, format, easy of use, and timeliness. Questionnaire to measure user satisfaction of information system in this study was adopted from a questionnaire compiled by Doll and Torkzadeh (1988), which has also been used in studies of Kim and McHaney (2000).

In this study, variable user satisfaction is abbreviated as KP. Indicators for user satisfaction consists of 12 question items with a five Likert scale ranging from very disagree to very agree. The higher the score of this variable, mean user satisfaction over the using of accounting drylab the higher perceived by the user and vice versa.

Observed variables

Observed variables also called manifest variables or observed variables (Ghazali, 2005). Unobserved variables are variables that can be observed or measured empirically which is also often referred to as an indicator (Wijanto, 2006). The observed variable is the effect or the size of the latent variables. Variable is observed in this study consisted of 34 baseline variables that constitute the existing question items in the questionnaire.

KS.

For latent variable quality of information systems (KS) consists of ten observed variables. Observed variables in the path diagram is abbreviated as KS, from KS1 to KS10.

KC

KC was observed variables as indicators of a latent variable quality of information. This variable consists of six indicators in the path diagram of this study, written as KC1 up with KC6.

DS

latent variables perceived usefulness had 6 observed variables, and in the path diagram is written as DS1 up with DS6.

Latent Variable Scores

Special for latent variables user satisfaction of is a confirmatory factor analysis (CFA) of five components: content, accuracy, format, ease of use and timeliness. Each of these components in the initial model is a latent variable in the path diagram is written as Content, Accuracy, Format, Ease and Time. Content have been observed by 4 variable, and written in the path diagram KP 1 until KP4. Accuracy in this study has been observed by 2 variables and written in the path diagram as KP 5 to KP6. Format in this study has 2 observed variables, in the path diagram is written as KP7 to KP8. Ease of use in this study has 2 observed variables, in the path diagram is written as KP9 until KP10. Time variables has 2 observable variables, in the path diagram is written as KP11 until KP12. After calculating the scores for the five latent variable content, accuracy, format, Ease and Time, then the five latent variables and the observed variables into the research model will be simpler.

TEST ANALYSIS AND RESULTS

250 questionnaires was sent to respondents, but only 165 questionnaires returned. So the response rate of the questionnaires was 66% of the total questionnaires sent. Of that amount back, there are 20 questionnaires could not be included in the sample because it does not meet the criteria for the selection of samples or incomplete filling. The number of samples that can be obtained final test is included in the 145 questionnaires. The data collection period is for four months from February 2014 until April 2014.

The number of respondents who are qualified to analyze as many as 145 people. The total number of manifest variables (indicators) are 34 questions that represent the five constructs which are system quality, information quality, perceived usefulness, and user satisfaction. Testing is done by following the steps that apply in the SEM using the method of maximum likelihood estimation (MLE). There is a two-step testing should be performed (Hair et al., 1995) that is testing the suitability of the measurement model and structural model fit.

1. Overall Model Suitability

Structural model in SEM analysis begins with testing the overall model fit is seen by the indicator Goodness-of-fit index (GFI) statistics of the output of LISREL (Hair et al., 1995). Overall summary of the critical value of the test the suitability of the overall model can be seen from the summary in Table 1.

Table 1.
Overall Model Suitability

Models Criteria for Suitability	Compatibility Level Indicator	Model Estimation Results	Level of Suitability Model
RMSEA P (close fit)	RMSEA < 0,08	0.22	Not Good
	P < 0.05	0.00	Good
ECVI	Smaller values of Independence and closer to the Saturated Model	$M^* = 17.13$ $S^{**} = 5.25$ $I^{***} = 97.07$	Good fit
AIC	Smaller values of Independence and closer	$M^* = 967.60$ $S^{**} = 756.00$	Good fit

	to the Saturated Model	$I^{***} =$ 13978.41	
CAIC	Smaller values of Independence and closer to the Saturated Model	$M^* =$ 2806.20 $S^{**} =$ 2259.21 $I^{***} =$ 14085.78	Good fit
NFI	$NFI > 0,90$	0,95	Good fit
NNFI	$NNFI > 90$	0,96	Good fit
CFI	$CFI > 0,90$	0,97	Good fit
IFI	$IFI > 0,90$	0,97	Good fit
RFI	$RFI > 0,90$	0,94	Good fit
RMR	Standardized RMR < 0.05	0.01	Good
GFI	$GFI > 0,90$, <i>good fit</i> ; $0.90 < GFI > 0.80$, <i>marginal fit</i>	0,84	Marginal fit

$M^* =$ Model $S^{**} =$ Saturated $I^{***} =$ Independence

By looking at the overall results of the estimation based on existing criteria, the overall values obtained are good. So from the results of an analysis of the reliability of the output for testing the overall model, it can be concluded that the model is a good fit or good.

Validity Test

Tests on the validity of a grain of questions indicated by the value of t and the standardized loading factor. For values of t must be above a critical value is 1.96 and the standardized factor loading greater than 0.5 (Iqbaria et al., 1997). Question items that do not meet the criteria for a valid test can not be included in the next. The load factor for each indicator on its latent variable is presented in the form of the relationships depicted in the path diagram obtained by running the LISREL program.

Variable User Satisfaction is a confirmatory analysis measured by two stages. First, the latent variables measured using observable variables that second order of five dimensions

into the indicator. The second step is to calculate the scores for the five latent variables into dimensions of user satisfaction variables. This score is used as an indicator of user satisfaction through a fifth dimension that has become the observed variables. This variable has five dimensions, namely the content, accuracy, format, ease of use, and timeliness.

Content is measured by 4 (four) of the observed variables KP1 to KP4. Accuracy is measured with 2 (two) variables observed that KP5 and KP6. Format, is measured by two observed variables from KP7 to KP8. Ease of use was measured by two observed variables, namely KP9 and KP10. Timeliness was measured by two observed variables namely KP11 and KP12. From the results of running the program Lisrel for KP twelve variables, all indicators have the t-value above the critical value of 1.96 and the value of the standardized factor loading are above 0.5. This means that all indicators are valid, so there is no indicator that should be discarded. These results are then used to calculate the latent variable scores of user satisfaction which has five dimensions, namely Content, Accuracy, Format, Ease of use, and timeliness. The results showed that the entire processing this indicator variable has a value of standardized loading factor above 0.5. This means that the variable content, accuracy, format, ease of use, and timeliness meet valid criteria to represent the construct being measured which is user satisfaction.

For system quality variable, the results indicate that all standardized loading factor values for KS1 to KS10 are more than 0.5. So, these variables can be used in the next test because it does represent the construct of system quality. For the indicator variables of the latent variable information quality, the results showed that no variable has a value of standardized loading factor below 0.5. This means that all the observed variables of information quality which is KC1 to KC6 can be used in subsequent testing. Meanwhile for perceived usefulness variable, the overall value of the standardized loading factor is significant, because from DS1 to DS6 has t-value above 0.5. So from the six variables was observed for the latent variables, can be used for further testing because it represents the construct being measured. Of the total 34 observed variables as indicators for each latent variable in this study, all variables can be included in subsequent testing. LISREL output processing results for each latent variable can be seen in the appendix.

Reliability test

Reliability test aims to test the consistency of the grains have a question or statement in the questionnaire. To test the reliability of the variables, we have to calculate the construct

reliability (CR) and variance extracted (VE) from each of the observed variables (Hair et al. (1995). If the calculation results of the construct reliability greater than 0.70, and the variance extracted is greater than 0.50, it can be said that the construct had good reliability (Wijanto, 2008). The figures are used to calculate Reliability Construct and Variance Extracted taken from the output Completely Standardized Solution of the data processing. The summary of CR and VE calculations for each latent variable, are presented in Table 2.

Table 2.

Construct Reliability and Variance-Extracted Value of Each Latent Variable

Latent Variabel	CR value ≥0.70	VE Value ≥ 0.50	Summary
System Quality (KS)	0.956	0.741	Good
Information Quality (KC)	0.962	0.809	Good
Perceived Usefulness (DS)	0.932	0.700	Good
User Satisfaction (KP)	0.934	0.740	Good

Structural Model Suitability

The analysis is performed on the structural equation coefficients by specifying a certain level of significance. Analysis of the structural model to test the hypotheses proposed in this study. For a significance level of 0.05, the value t of structural equation must be greater or equal to 1.96 or greater for practical equal to 2 (Wijanto, 2008). Of the overall hypothesis, generate 3 equations which means there are three structural models proposed.

Structural Equation Model 1:

H1: System Quality has positive effect on Perceived of Usefulness

H2: Information Quality has positive effect on Perceived of Usefulness

$$DS = 0.47*KS + 0.23*KC, \text{Errorvar.} = 0.65, R^2 = 0.35$$

$$(0.097) \quad (0.082) \quad (0.17)$$

$$4.80 \quad 2.82 \quad 3.79$$

From the first structural equation in the model above can be seen in the figure below, all coefficients have significant t values. This equation is an equation for the first and second hypothesis. It can be concluded that the hypothesis H1 and H2 in this study is significantly proved.

Structural Model 2:

H3: System Quality has a positive effect on the User Satisfaction.

H4: Information Quality has a positive effect on User Satisfaction.

H5: Perceived Usefulness has a positive effect on User Satisfaction.

$$KP = 0.46*DS + 0.47*KS + 0.13*KC, \text{Errorvar.} = 0.22, R^2 = 0.78$$

$$(0.077) \quad (0.061) \quad (0.050) \quad (0.033)$$

$$5.97 \quad 7.71 \quad 2.57 \quad 6.79$$

For the equation in this second model, also shown that all coefficients have significant t values above 1.96. So the conclusion that can be drawn is that the H3, H4, and H5 are also proven. From the second equation shows that the models have to offer a good level of significance for the t value is above the critical value of 1.96. This shows that all the coefficients for the first and second equation is significant. The Summary of t-value of each latent variable, are presented in Table 3.

Table 3. t-value for each hypothesis

Hypothesis	Path	Estimation	t-value	Summary
H1	KS → DS	0.46	5.97	Significant
H2	KC → DS	0.47	7.71	Significant
H3	KS → KP	0.47	4.80	Significant
H4	KC → KP	0.13	2.57	Significant
H5	DS → KP	0.23	2.82	Significant

The results of the path diagram in Figure 3 below, shows the structural model generated from Lisrel output.

Figure 3. Path Diagram

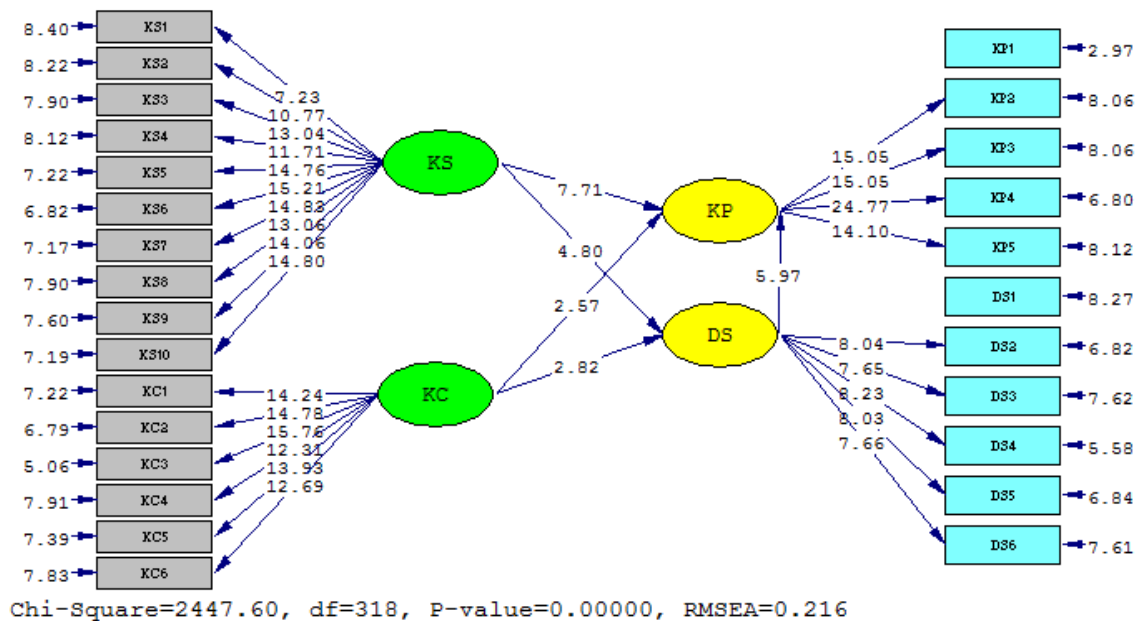

Test Results Analysis

Based on structural equation models testing were produced and confirmed that the system quality is significantly affect perceived usefulness. These results reinforce previous studies of Adams et al (1992), Mao and Palvia (2006), as well as Simon and Paper (2007). The influence of the system quality by Davis et al., (1989) and Chin and Todd (1995) which

is defined as the ease of use is the perceived usefulness also supports the findings of Rai et al., (2002) and Gumaraes et al., (2007) .

The second hypothesis examines the effect of information quality on the perceived usefulness of positive results also proved significant. These results also support the findings of Seddon (1997), Li (1997) and Rai et al., (2002). This indicates that the higher the quality of information produced by the accounting software used, will increase the perceived usefulness views of user perception.

The third hypothesis regarding the effect of system quality on user satisfaction, the results proved to be significantly positive. These results are consistent with the results obtained by DeLone and McLean (1992), McKiney et al., (2002), Rai et al., (2002), and Livari (2005). It can be concluded that based on the perception of the user, the higher the quality of accounting software, will further enhance the software user satisfaction.

The fourth hypothesis testing on the effect of information quality on user satisfaction results proved significant positive. These results support the results of previous studies that DeLone and McLean (1992), and Livari (2005). With these results we can conclude that the higher the quality of information produced by the accounting software used, will further improve user satisfaction, according to their perception.

Test results on the effect of perceived usefulness H5 against user satisfaction also proved significant, in line with the results of the research DeLone and McLean (1992). These results also support the model of Seddon (1997), Rai et al., (2002) and also Livari (2005). This gives the conclusion that the higher the level of perceived usefulness, user satisfaction will increase accounting software, based on their perception.

This research is motivated by numerous previous studies conducted related to the model of information system success. The purpose of this study is to see the extent of accounting software in terms of the perception of the user by implementing information systems success model of DeLone and McLean (1992) and Seddon (1997) modified by adding a variable confirmatory factor analysis to the user satisfaction. This model is used to test the primary data obtained via questionnaires 239 respondents.

This study contributes to the information systems success model of DeLone and McLean (1992) and Seddon (1997) by adding a variable confirmatory factor analysis to the

user satisfaction. The addition of CFA will help identify the validity and reliability of each indicator variable into user satisfaction instrument built by Doll and Torkzadeh (1988).

Conclusion

There are five hypotheses developed in this study which is a model of the relationships that exist in the success of information systems of DeLone and McLean (1992) and Seddon models (1997), and summarized by Rai et al., (2002). After testing the hypotheses proposed in this study, it produced some conclusions which are System Quality proved to be significantly positive effect on perceived usefulness. Information Quality proved to be significantly positive effect on perceived usefulness. System Quality proved to be significantly positive effect on user satisfaction.

Information Quality proved to be significantly positive influence on User Satisfaction. Perceived usefulness proved to be significantly positive effect on User Satisfaction. The results also lead to the conclusion that all the instruments of research into user satisfaction indicators has a good validity and reliability.

References:

- [1]. Adams, D.A., Nelson, R.R., and Todd, Peter, A., 1992, "*Perceived Usefulness, Ease of Use, and Usage of Information Technology A Replication*" MIS Quarterly, June.
- [2]. Almutairi, H. & Subramanian, Girish, H., 2005, "*An Empirical of the DeLone and McLean Model in the Kuwaiti Private Sector*", The Journal of Computer Information System, Spring, 45,3,pg.113.
- Chin, Wynne. W., and Todd, Peter, A., 1995, "*On the Use, Usefulness, and Ease of Use A Structural Equation Modeling in MIS Research: A Note of Caution*", MIS Quarterly, June.
- Davis, Fred D., (1989), "*Perceived Usefulness, Perceived Ease of Use, and User Acceptance of Information Technology*", MIS Quarterly, September, pp.319- 340
- Davis, Fred D., Bagozzi, Richard P., dan Warshaw, Paul R., (1989), "*User Acceptance Of Computer Technology: A Comparison Two Theoretical Models*" Management Science, August, pp.982-1003
- DeLone, W.H., (1988). "*Determinants of Success for Computer Usage in Small Business*". MIS Quarterly/March. Pp. 51-61.
- DeLone, W.H., and Ephraim R. Mclean, 1992, "*Information System Success: The Quest for the Dependent Variable*". Information System Research, March, 60-95.

- Doll, W.J., and Torkzadeh, G, 1988, "*The Measurement of End User Computing Satisfaction*", MIS Quarterly, 12, (2), 159-174.
- Goodhue, D.L., and Thompson, R.L., 1995, "*Task-Technology Fit and Individual Performance*", MIS Quarterly, 19 (2), 213-236.
- Guimaraes, T., M. Igbaria, and M. Lu. 1992. "*The determinants of DSS success: An integrated model.*" Decision Sciences 23, no. 2: 409-430.
- Guimaraes, T., D. S. Staples, dan J. D. McKeen, 2003. "*Empirically Testing Some Main User-Related Factor for Systems Development Quality*". Quality Management Journal 10, No. 4: 39- 54.
- Hair, J.F. Jr., Anderson, R.E., Tathan, R.L., dan Black, W.C. 1998. "*Multivariate Data Analysis*". Fifth Edition. Prentice-Hall International Inc.
- Imam Ghazali. (2005) "*Model Persamaan Struktural*" Badan Penerbit Universitas Diponegoro.
- Istianingsih and Setyo Hari Wijanto. (2008). Pengaruh Kualitas Sistem Informasi, Perceived Usefulness, dan kualitas Informasi terhadap Kepuasan Pengguna Akhir Software Akuntansi. Universitas Indonesia. Unpublish.
- Iqbaria, M. and Tan, 1997, "*The Consequences Of Information Technology Acceptance On Subsequent Individual Performance*"
- Janson, M. A., and Subramanian, A., 1996, "*Packaged software: Selection and Implementation Policies*".INFOR, 34(2), 133-151.
- Kim, Sung & McHaney, Roger, 2000, "*Validation of End-User Computing Satisfaction Instrument in Case Tool Environments*", The Journal of Computer Information System, vol.41.,Iss. 1: pg.49.
- Klenke, K. (1992). *Construct Measurement In Management Information System: A Review And Critique Of User Satisfaction And User Involment Instruments*. INFOR, 30(4), 325-348.
- Lee, D.M., 1986, "*Usage Pattern and Source of persistence for Personal Computer Users*", MIS Quarterly, 10,4, 313-325.
- Li, C. 1997. "*ERP packages: What's next?*",Information System Management, 16(3), 31–35.
- Livari,Juhani, 2005, "*An Empirical Test of the DeLone and McLean Model of Information System Success*", Database for Advances in Information Systems, Spring,, 36,2.pg.8.
- Mao, En and Prashant Palvia, 2006. "*Testing an Extended Model of IT Acceptance in the Chinese Cultural Context.*" The Database for Advances in Information System 37, Spring 2006.

- McHaney, R., and Cronan, T. P., 2001, “ *A Comparison of Surrogate Success Measures in On-Going Representational Decision Support Systems: An Extension to Simulation Technology*”, *Journal of End User Computing*, 13, 2.
- McKinney, V., Yoon, K., and Zahedi, Fatemeh, 2002, “ *The Measurement of Web-Customer Satisfaction: An Expectation and Disconfirmation Approach*”, *Information System Research*, 13,3.
- Melone N.P. 1990,”*A Theoretical Assessment of The User Satisfaction Construct in Information System Research*”, *Management Science*. January.
- McLeod, R. Jr., and Schell, George, (2001). “*Management Information System,*”. Eight Edition, Prentice-Hall, Inc. Upper Saddle River, New Jersey.
- McGill, Tanya, Hobbs, Valerie, & Klobas, Jane, 2003, “*User-Developed Applications and Information Systems Success: a Test of DeLone and McLean’s Model*”, *Information resource Management Journal*; Jan-Mar; 16.1.pg.24.
- McHaney, R., and Cronan P.T., 2001,” *A Comparison of Surrogate Success Measure in On-Going Representational DSS: An Extension to Simulation Technology*”, *Journal of End-user Computing*; Apr-Jun; 13,2.
- Rai, A., Lang, S.S. and Welker, R.B., 2002, ”*Assessing the Validity of IS Success Models: An Empirical Test and Theoretical Analysis*”, *Information System Research*, Vol.13, No.1. pp. 29-34.
- Sekaran, U., (2003). “*Research Methods for Business : A Skill-Building Approach*” (Fourth Edition). John Willey & Sons, Inc.
- Seddon.P.B. 1997,”*A Respecification and Extension of The DeLone and McLean’s Model of IS Success*”, *Information System Research*.8.September. 240-250.
- Simon, Steven J., and Paper, David, 2007., “ *User Acceptance of Voice Recognition Technology: An Empirical Extension of The Technology Acceptance Model*” *Journal of Organizational and End-User Computing*, 19(1), 24-50.
- Staples, Sandy D. dan Seddon, 2004, “*Testing the Technology-To-Performance Chain Model*”, *Journal of Organizational and End User Computing*, Oct-Dec. pp17- 35
- Toni M Somers; Klara Nelson; Jahangir Karimi, 2003. ” *Confirmatory Factor Analysis of the End-User Computing Satisfaction Instrument: Replication within an ERP domain*” *Decision Science*, 34 (3) 595-621
- Webber, Ron, 1999, *Information System Control and Audit*, First Edition, Upper Saddle River, New Jersey: Prentice Hall Inc.
- Wijanto, Setyo Hari, 2006, “ *Structural Equation Model (SEM) dengan Lisrel 8.7*”, *Catatan Kuliah, Pascasarjana Ilmu Manajemen, Universitas Indonesia*.

Wijanto, Setyo Hari, 2008, “ *Structural Equation Model (SEM) dengan Lisrel 8.8, Konsep dan Tutorial*”, Graha Ilmu.

Widjayanto, Nugroho, 2001, “*Sistem Informasi Akuntansi*”, Penerbit Erlangga.

Yoon, Y., T. Guimaraes, and Q. O’Neal. 1995, “*Exploring the factors associated with expert systems success*”, MIS Quarterly 19, no. 1: 83-106.