

Challenges with the design of cost effective series DC collection network for offshore wind-farm

Mohammad Kharezy

High voltage Measurement Science and Technology
RISE Research Institutes of Sweden
Borås, Sweden
Mohammad.kharezy@ri.se

Torbjörn Thiringer

Department of Electrical Engineering
Chalmers University of Technology
Gothenburg, Sweden
Torbjorn.thiringer@chalmers.se

Abstract— This article summarizes a current PhD research project at Chalmers University of Technology financed by the Swedish Energy Agency and with the contribution of RISE Research Institutes of Sweden. The aim is to study the size of a high-power DC/DC converter which is fit into a container outside a wind turbine for direct integration of an offshore DC series connected wind power plant. This becomes possible using an isolation transformer having a medium frequency high voltage withstand as well as a very high HVDC insulation level. Both obtainable voltage strength levels, as well as life-time of the insulation system are issues that are going to be investigated carefully.

Keywords- Power transformer insulation; Solid state transformer; Series HVDC grid integration; High frequency insulation; High power isolated DC-DC converters; Medium frequency high power transformer.

I. INTRODUCTION

Today, when a sea-based wind park reaches a size of 100 MW or more, a platform, acting as the hub in the collection grid and a point of connection for the cable to land is needed. Among other equipment, the platform carries a transformer. Since ordinary AC cables becomes inefficient over about 100 km, it has become necessary to move over to DC transmission for some of the new wind parks [1]. However, in today's solutions, within the wind park, still a collection grid running at 50 Hz AC is used and platforms of gigantic sizes are needed for 50 Hz AC/AC and AC/DC conversion increasing the cost substantially for the wind energy installation [2].

A possibility here is to use DC technology for the energy collection grid within the wind park. To do that, a key component is missing, the high-power DC/DC converter. Such a device can transform the voltage from the wind turbine to a high DC voltage using a much smaller converter unit compared to a 50 Hz transformer. An idea is to fit the converter system into a container placed on the outside of a wind turbine, thus utilizing the existing foundation out in the sea.

A highly interesting solution is then to connect the output of the wind turbine converters in series, and in this way making the voltage level to reach 100, 150 or even 200 kV. The idea would then be to continue the connection directly to

shore without the need of a large transformer platform. A cable can transport up to 2 kA, and using a bipolar set-up, 800 MW can be reached without a platform, for the 200-kV bipolar case. This is a huge investment saving. However, here comes a highly important factor: The wind turbine that is located closest to the bulk DC-transmission cables going away to the shore must take up the full insulation on its high-voltage side (see Figure 1). Today, the DC/DC converter technology is far away from such capabilities. This is where the proposed project comes in.

The presented study tries to clarify the challenges with the converter insulation design and characterization of the insulation material used, where the main task is to reduce the power density and to increase the efficiency of the unit. Both obtainable voltage strength levels for a defined application volume and weight of the DC/DC converter are issues that must carefully be investigated.

Some guide lines are suggested as future work possibilities for those who are interested in the high voltage insulation aspects of this comprehensive task.

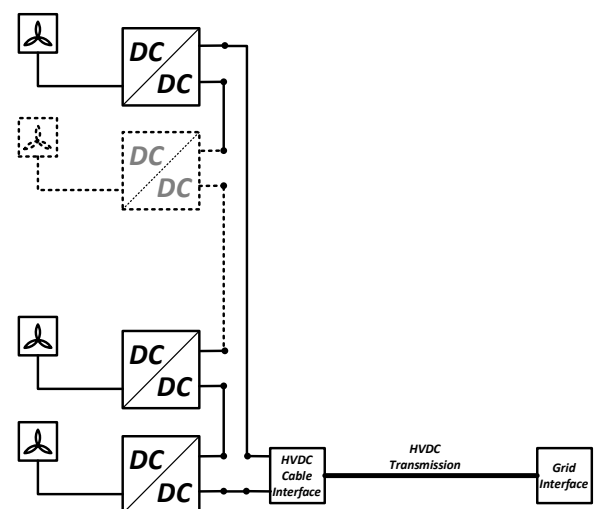

Figure 1. A series HVDC offshore wind power plant integration network

II. CHALLENGES WITH THE DESIGN OF A MEDIUM-FREQUENCY POWER TRANSFORMER

A. General

Medium-Frequency Power Transformers (MFPT) are the key elements of high-power density isolated DC/DC converters which can be used in weight and volume restricted applications such as off-shore wind powerplants. The main requirements of this type of converters, i.e., high power density, lower specific losses, voltage adaptation and isolation requirements are entirely or to a great extent to be fulfilled through a careful design of the used MFPTs [3].

However, when taking high power, high voltage and high frequency effects into account, there are several challenges to be addressed. A series of challenges are basically related to the extra losses, as a result of eddy currents in the magnetic core, excess losses in the windings due to enhanced skin and proximity effects [4]. These includes as well, calculations of the parasitic elements, i.e., leakage inductance and winding capacitances, causing excess switching losses in the power semiconductors, which are usually the dominant power losses at higher frequencies [5]. The high-power density of the transformer lead to high loss densities requiring a proper thermal management scheme in order to dissipate these power losses from a smaller component.

Due to the promising features of MFPTs, many research activities focus on their design and optimization; however only a few documented research activities treat their insulation system design and verification. Standards or defined test methods are rarely addressed the insulation materials for a MFPT which typically runs on medium frequency (<20 kHz) square wave shape voltage with rise times in the micro second range. Standards generally specify tests of electrical properties of insulations at frequencies lower than 60 Hz. They present information for the determination of dielectric properties of insulating materials, however no information is given about withstand or endurance testing methods of insulation materials at frequencies higher than 60 Hz [6].

At the moment, to design a MFPT, one should rely on insulation materials datasheets for 50-60 Hz frequencies and use a conservative safety factor. In this way the final design is far from optimized, and also the failure rate will be unknown and finally the designs will not be comparable with each other. A study shows that, low frequency withstand tests on insulation materials or test objects are not representative for the establishing of the withstand condition of the same material at higher frequencies [7].

Another challenge is with the requirement for an HVDC design. For the suggested HVDC collection network shown in Figure 1, the converter which has the 'highest potential place' in the series connected concept (number n) can experience a high DC voltage (nV_s) to ground while the LV side have a much lower symmetrical square-wave voltage of V_p to ground (see Figure 2). This means that the transformer's HV winding-core, HV winding-LV winding and HV winding-body insulations should be dimensioned for a high DC voltage (HVDC insulation Concept). At the same time, the HV winding-core, LV winding-body and turn-turn insulations both for LV and HV windings should be dimensioned for a medium frequency square wave AC voltage (AC insulation concept).

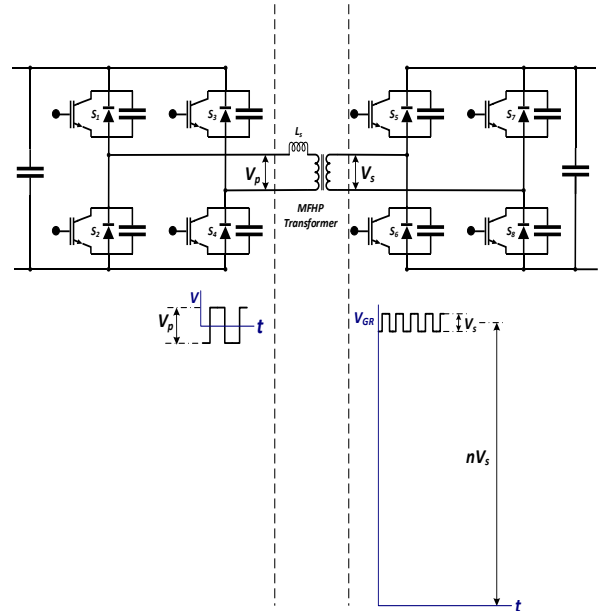

Figure 2. HV winding of a MFPT subjected to HVDC stress to ground.

A review of previous activities claiming to consider the high voltage insulation issues of the MFPTs reveals that the insulation designs are based on kV/mm high voltage strength figures of the insulation materials. These values are extracted from manufacturers data sheets and is commonly applicable for the low frequency applications. There are rarely investigations made about the insulation strength under high frequency stress. In most of the cases a rough safety factor is used to cover the other unforeseen effects. An available written documentation has not been found that presents a high HVDC voltage to ground design. In the scope of reviewed documents, for the active parts considered to be placed in transformer oil, neither the long-term effects of oil to the insulation materials used as coil-formers or barriers have been investigated nor a suitable thermal design has been performed.

B. Insulation material strength at high frequency

A Gigre, WG D1.43 brochure published in 2011, focuses on the reduced reliability of electrical network components because of the introduction of power electronics equipment to the network. Accelerated degradation by repetitive pulses and examples of available solutions are discussed in this publication [7]. At high frequencies, the insulation materials do not behave as they do at the usual 50/60 Hz power frequency. For each cycle, the dielectric loss can be assumed constant, so by having a higher frequency, the heating effect will be higher for the same time period [8].

Transient voltages, high harmonics voltages and switching frequency voltages can increase the thermal stress in the insulation and result in shorter service life. For epoxy-mica insulation systems, it has been shown that, over a certain range of frequencies and voltages, the ratio of the number of electrical cycles to failure can be considered unchanged, but it doesn't mean that for all other insulation systems, the low frequency test data can be used for life assessment purpose at higher frequencies [9].

The standards used by industry to characterize the high voltage insulation material have not fully adopted to this new need. IEC 60851-5, IEC 60243-1 or ASTM D149 specify tests of electrical properties of insulations at frequencies lower than

60 Hz. IEC 60250 or ASTM D150 are used for the determination of dielectric properties of insulating materials, however no information is given about the voltage withstand ability or endurance testing methods of insulation materials at frequencies higher than 60 Hz.

For power transformers, IEC 60076-11 together with IEC 60076-3 cover dielectric tests only at power frequencies and the IEC 60664 and IEC 61558 series are about safety measures for transformers only up to 25 kVA. However, in the rotating machine field there is existing valuable information; IEC 60034-18-41 describes qualification testing of rotating machines fed from voltage converters under high frequency stress.

Based on guidelines presented in the above-mentioned standards and previous research activity results, a set of verification tests shall be implemented both to characterize insulation materials for a MFPT and to assure the insulation quality of the manufactured transformers.

Breakdown Voltage (BDV) tests performed by the author to investigate the effect of wave shape and frequency on the breakdown voltage of a type of litz wire and an insulation tape shows that compared with low frequency tests, the BDVs are much lower at tests with high frequency voltages.

C. Transformer insulation under HVDC stress

A review of the test results of the MFPTs presented in several articles demonstrates that, it is nearly impossible to have a Partial Discharge (PD) free design when the line to ground voltage is higher than 35kV (examples are [10] and [11]). Using transformer oil will dramatically increase the PD inception (start) level [12]. A PD free service is one of most important factors that guarantees a long-life period for any high voltage component.

AC insulation designs of oil type power transformers have been successfully performed for more than a century and well established methods are presented in different sources [13]. However, switching to an HVDC design, many challenges shows up [14].

For AC voltage stress, the electric field is higher in the oil gap having a lower permittivity than in the insulation barriers which have a higher permittivity and it is the oil gap which has a dominant effect on the AC voltage strength of the system. This fact is a base for a reliable oil gap-based insulation design of AC transformers. However, for DC voltage stress, the electric field is lower in the oil gaps having a higher conductivity than in the barriers which have a lower conductivity and it is the barrier thickness which has a dominant effect on the DC voltage strength. As a result, an HVDC transformer design should include both a high volume of oil and high thickness of the solid paper insulation. In addition, directly after switching in an HVDC voltage, the capacitive field is charged and as it was explained, in this moment, it is the permittivity of the materials which determines the voltage drop over the combined insulation system. A long time after switching, the resistive field is dominant, and it is the conductivity of the materials which determines the voltage drop over the combined insulation system.

Table I shows how an HVDC transformer insulation system should withstand a peak voltage of DC, both as a capacitively and resistively divided voltage distribution

system and figures 3 and 4 demonstrate the equipotential lines and the electric field stress when an AC or a DC voltage is applied to a high voltage to ground electrodes pair.

TABLE I. INSULATION SYSTEM DESIGN; AC VERSUS DC

DC at the instant of switching or AC 100kV	DC steady state 100 kV
upper and lower layers 9 mm transformer oil	Middle layer 4 mm transformer board barrier
Relative permittivity ϵ_r Mineral oil 2.2, Transformer board 4.4	DC conductivity σ (S/m) Mineral oil 10-13, Transformer board 10-15
$E_i = \frac{V}{\epsilon_i \left[\frac{d_{oil}}{\epsilon_{oil}} + \frac{d_{board}}{\epsilon_{board}} + \frac{d_{oil}}{\epsilon_{oil}} \right]}$	$E_i = \frac{V}{\sigma_i \left[\frac{d_{oil}}{\sigma_{oil}} + \frac{d_{board}}{\sigma_{board}} + \frac{d_{oil}}{\sigma_{oil}} \right]}$
Voltage over 3 layers of insulation (kV) 45 10 45	Voltage over 3 layers of insulation (kV) 2 96 2
Electric field over 3 layers of insulation (kV/mm) 5 2.5 5	Electric field over 3 layers of insulation (kV/mm) 0.2 24 0.2

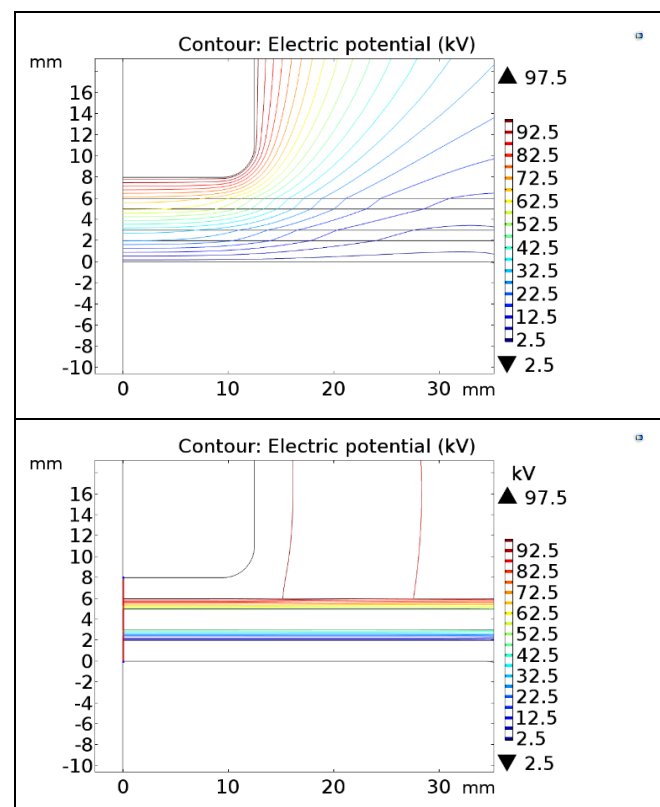

Figure 3. Two electrodes supplied with 100kV to ground, and two solid barriers in transformer oil (Upper: AC, Lower: DC)

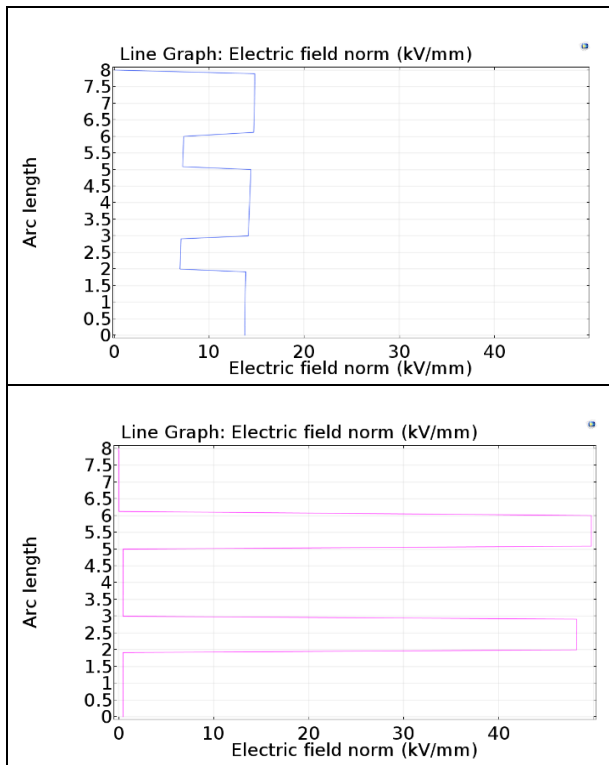

Figure 4. Electric field stress inside the insulation system introduced in Figure 3 (Upper: AC, Lower: DC)

Another challenge arises with a dynamic voltage distribution when a transformer is exposed to an HVDC voltage. The conductivity of the insulation materials are not constant values. The temperature, the time of application of voltage, and the magnitude of applied voltage have a direct effect on the conductivity of the insulation material [15].

The situation is more complicated if for example, the conductivity of one of the oil layers has a slight difference from the conductivity of the other oil layers. A slight temperature variation between the oil layer directly adjacent to the winding compared with the oil layer behind a solid barrier, can easily lead to this deviation. Figure 4 presents an example, when this difference is in the order of 10. Such a difference can also be a result of humidity, or even for the oil of the same type, a different production process [14]. The electric stress inside the oil layer goes higher than the value which is supposed to be highest at the moment of applying the voltage (based on a capacitive division) and reaches the top value of 7.8 kV/mm (see Figure 5).

Many standards have presented methods for conductivity measurements of the liquid or solid insulation materials [16]. The result of a comprehensive study shows that none of these standard methods guarantee both reproducible and comparable results with the conductivities under HVDC test or service conditions [15]. Based on the guidelines presented in the reference 15, a test setup should be papered, and several series of measurements should be done at actual temperature and voltage stress conditions.

III. CONCLUSION

This paper describes the aspects that have to be considered for a medium frequency high voltage high power isolation transformer inside of a DC/DC converter used for series HVDC platform-free integration of offshore wind power plants where it is exposed to both AC as well as DC stress.

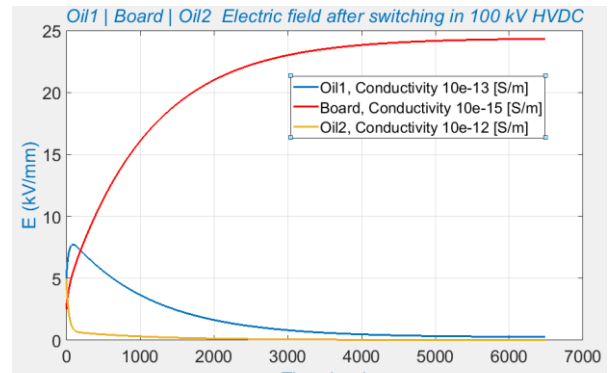

Figure 5. Electric field during transient state inside two oil layers having different conductivities and one transformer board layer

ACKNOWLEDGMENT

This project has been funded by the Swedish Energy Agency and with in-kind contribution of Rise Research Institutes of Sweden.

REFERENCES

- [1] Available: <http://new.abb.com/systems/hvdc/why-hvdc/economic-and-environmental-advantages>.
- [2] Available: <http://renews.biz/108577/wpd-transforms-nordergrunde/>.
- [3] M. A. Bahmani, T. Thiringer, and M. Kharezy, "Design Methodology and Optimization of a Medium-Frequency Transformer for High-Power DC-DC Applications," IEEE Transactions On Industry Applications, Vol. 52, No. 5, September/October 2016.
- [4] M. A. Bahmani, T. Thiringer, and H. Jimenez, "An accurate pseudo-empirical model of winding loss calculation for HF foil and round conductors in switchmode magnetics," IEEE Trans. Power Electron., vol. PP, no. 99, pp. 1–1, 2013.
- [5] M. A. Bahmani and T. Thiringer, "Accurate evaluation of leakage inductance in high frequency transformers using an improved frequency-dependent expression," IEEE Trans. Power Electron., vol. PP, no. 99, pp. 1–1, 2014.
- [6] IEC 60851-5, IEC 60243-1, ASTM D149 IEC 60250 or ASTM D150.
- [7] A. Cavallini, D. Fabiani and others, "Insulation degradation under fast repetitive voltage pulses," Gigre WG D1.43 Brochure, 2011.
- [8] N. Hardt and D. Koenig, "Testing of insulating materials at high frequencies and high voltage based on the tesla transformer principle," Electrical Insulation, 1998. Conference Record of the 1998 IEEE International Symposium on, Arlington, VA, 1998.
- [9] G. C. Stone, R. G. van Heeswijk and R. Bartnikas, "Investigation of the effect of repetitive voltage surges on epoxy insulation," in IEEE Transactions on Energy Conversion, vol. 7, no. 4, pp. 754-760, Dec 1992.
- [10] Spezial-Transformatoren-Stockach. (2015). "MF Transformer for Traction," Available: http://www.sts-trafo.com/fileadmin/user_upload/messeposter_rail_kor2.pdf.
- [11] T. B. Gradinger, U. Drogenik, and S. Alvarez, "Novel insulation concept for an MV dry-cast medium-frequency transformer," in 2017 19th European Conference on Power Electronics and Applications (EPE'17 ECCE Europe), 2017, pp. P.1-P.10.
- [12] M. Jaritz, S. Blume, and J. Biela, "Design procedure of a 14.4 kV, 100 kHz transformer with a high isolation voltage (115 kV)," IEEE Transactions on Dielectrics and Electrical Insulation, vol. 24, no. 4, pp. 2094-2104, 2017.
- [13] S. V. Kulkarni and S.A. Khaparde, "Transformer Engineering; Design, Technology and Diagnostics," Taylor & Francis Group publication, 2013.
- [14] A. Küchler, "High Voltage Engineering: Fundamentals-Technology-Applications," Springer publication, 2017.
- [15] Cigré working group A2/D1.41, "Technical Brochure 646: HVDC transformer insulation: Oil conductivity", 2016, pp. 1-93.
- [16] IEC 61620 1998, IEC 60247 2004, ASTM D1169 2011, IEC 62631-3-1&2 2016 or ASTM D257 2014.