

THESIS FOR THE DEGREE OF DOCTOR OF PHILOSOPHY

Oxy-Fuel Combustion
- The Control of Nitrogen Oxides

FREDRIK NORMANN

Department of Energy and Environment
Division of Energy Technology
CHALMERS UNIVERSITY OF TECHNOLOGY
Göteborg, Sweden 2010

Oxy-Fuel Combustion – The Control of Nitrogen Oxides
FREDRIK NORMANN
ISBN 978-91-7385-401-6

© FREDRIK NORMANN, 2010

Doktorsavhandlingar vid Chalmers tekniska högskola
Ny serie nr 3082
ISSN 0346-718X

Department of Energy and Environment
Division of Energy Technology
Chalmers University of Technology
SE-412 96 Göteborg
Sweden
Telephone +46 (0)31-772 1000

Reproservice, Chalmers University of Technology
Göteborg, Sweden 2010

Oxy-Fuel Combustion - The Control of Nitrogen Oxides

FREDRIK NORMANN

Department of Energy and Environment
Chalmers University of Technology

ABSTRACT

Oxy-fuel combustion is one of the main candidates for carbon dioxide capture from power plants. In oxy-fuel combustion, oxygen diluted with recycled flue gas oxidizes the fuel. The elimination of air-borne nitrogen generates a flue gas that mainly consists of carbon dioxide and water. The carbon dioxide is compressed and separated from impurities to generate a stream suitable for storage. The emission of nitrogen oxides (NO_x), which is the topic of this thesis, is important in the construction of all power plants. In oxy-fuel power plants, NO_x may require consideration in the gas entering the flue gas treatment, in the gas ventilated to the atmosphere, and in the storage gas.

The combustion conditions of importance to nitrogen chemistry differ between the state of air and oxy-fuel operation due to the low concentration of air-borne nitrogen and the recycling of flue gases. This work investigates two combustion strategies for controlling the emission of NO_x from oxy-fuel combustion: 1) reburning and 2) what we call “high-temperature reduction”. Reburning reactions rapidly reduce NO_x , which is recycled back to the flame zone. Reburning is promoted by sub-stoichiometric combustion and by controlling combustion temperatures. The high-temperature reduction is made feasible by the low concentration of nitrogen in oxy-fuel combustion, which may reverse the Zeldovich mechanism (responsible for thermal NO_x formation) to reduce the NO_x formed from fuel-bound nitrogen. To achieve this result, a combustion strategy with low air-ingress, sub-stoichiometric conditions and high inlet oxygen concentration is required. In contrast with the strategy for reburning reduction, the combustion strategy for high-temperature reduction is not conventional, but benefits from reduced flue gas flow and efficient combustion.

An oxy-fuel power plant also offers expanded opportunities for controlling NO_x in the flue-gas treatment, which are reviewed in the present work. For example, the elevated pressure increases the formation of NO_2 , which may be absorbed in water. To find the optimal organisation of NO_x control in oxy-fuel power plants, further work is required to define the limits of NO_x , experimentally validate the proposed measures, and then evaluate the corresponding cost. It is of importance not to mimic the air-combustion in the development of oxy-fuel combustion, but rather utilize the broadened combustion conditions to arrive at the optimal performance with respect to emissions, combustion efficiency and investment.

Keywords: oxy-fuel; O_2/CO_2 ; combustion; NO_x ; nitrogen oxides; emission

List of Publications

This thesis is based on the findings contained in the following publications, referred to by Roman numerals in this thesis:

- I. Andersson, K., Normann, F., Johnsson, F. and Leckner, B. (2008). "NO emission during oxy-fuel combustion of lignite." *Industrial and Engineering Chemistry Research*, 47(6), 1835-1845.
- II. Normann, F., Andersson, K., Johnsson, F. and Leckner, B. (2010). "Reburning in oxy-fuel combustion: a parametric study of the combustion chemistry." *Submitted for publication*.
- III. Kühnemuth, D., Normann, F., Andersson, K., Johnsson, F. and Leckner, B. (2010). "Modeling reburning of nitric oxide in a 100 kW oxy-fuel flame." *Submitted for publication*.
- IV. Normann, F., Andersson, K., Leckner, B., and Johnsson, F. (2008). "High-temperature reduction of nitrogen oxides in oxy-fuel combustion." *Fuel*, 87 (17-18), 3579-3585.
- V. Normann, F., Andersson, K., Leckner, B., and Johnsson, F. (2010). "Emission control of nitrogen oxides in the oxy-fuel process." *Progress in Energy and Combustion Science*, 35 (5), 385-397.

Fredrik Normann is the principal author to Papers II, IV and V. In Paper I and III, Fredrik Normann performed the modelling work, while Klas Andersson and Daniel Kühnemuth performed the experimental work. Klas Andersson, Filip Johnsson, and Bo Leckner have contributed by discussing and editing to all papers.

Acknowledgements

This is to express my deep gratitude to my incredible team of supervisors for the time and knowledge they have shared with me. I wish to thank Klas Andersson for your truehearted support and enthusiasm of my work, Filip Johnsson for your drive to discover that has led us to where we are, Bo Leckner for your availability and strive towards perfection when everybody else had already given up, and Henrik Thunman for your ability to get things off the ground, including my doctoral studies.

The growing numbers of people involved in oxy-fuel combustion at Chalmers also deserve my gratitude for providing me with encouragement and valuable discussions. A special thanks goes to Daniel Kühnemuth, a co-author, for your efforts on my behalf at a time when your assistance was needed. To all the colleagues at the Division of Energy Technology, I wish to express my genuine appreciations for creating a working atmosphere that once experienced is impossible to live without.

The financial support by Vattenfall AB and the Swedish Energy Agency is hereby acknowledged.

I thank my family for raising me with the knowledge that anything is possible. To Ted and Mio for providing perspective on life. To my dear wife Lynga; you are my sunshine.

Tack,

Fredrik Normann
Göteborg 2010

Table of Contents

1	Introduction	1
1.1	Aim of Research	2
1.2	Content of the Thesis	3
2	Methodology	5
2.1	Detailed Reaction Mechanisms	5
2.2	Reactor and Mixing Assumptions	8
2.3	Overview of the Experimental Arrangement	10
3	Oxy-Fuel Power Plant Technology	13
3.1	Oxy-Fuel Combustion	14
3.2	Flue-Gas Train	17
3.3	Limitations for NO _x in Oxy-Fuel Power Plants	18
4	Research on NO_x in Oxy-Fuel Combustion	23
4.1	Early Work	23
4.2	Recent Work	24
5	Nitrogen Chemistry in Combustion	29
5.1	Fuel-N Release	30
5.2	Heterogeneous Reduction	32
5.3	Thermal NO _x	34
5.4	Prompt NO _x	35
5.5	Reburning	35
5.6	HCN and NH ₃ oxidation	36
6	Primary Measures for Oxy-Fuel Combustion	37
6.1	Reburning NO _x Reduction	37
6.2	High-Temperature NO _x Reduction	39
6.3	Combined Reduction	40
7	Secondary Measures for NO_x Control	41
7.1	Selective Reduction	42
7.2	Absorption of NO _x	43
7.3	Phase-Separation	44
8	Conclusion	45
8.1	Conclusions on Primary NO _x Control	45
8.2	Discussion on NO _x Control in Oxy-Fuel Power Plants	46
8.3	Future Work	49
9	References	51

1 - Introduction

As the main greenhouse gas carbon dioxide has during the last few years been considered a pollutant, with resulting discussions about strategies to limit the emission to the atmosphere. The development of power plants based on oxy-fuel combustion is a result of this discussion. Oxy-fuel power plants present lower efficiency than conventional power plants, but benefits from the possibility of efficient capture of carbon dioxide. Fossil fuels are currently our most abundant primary energy source, with the transportation sector dominated by oil. In Europe, 50% of the electricity generation derives from coal, and coal, together with natural gas, are responsible for about 70% of the carbon dioxide emissions. Our dependency on fossil fuels is expected to grow over the next few decades (IEA 2009). When fossil fuels are burned, carbon dioxide is an unavoidable by-product. Thus, if remaining fossil resources are to be exploited, it becomes necessary to capture and store carbon dioxide. Applying oxy-fuel combustion to coal fired power plants is one of the most promising methods to capture carbon dioxide, although major efforts in research and development remain before the method becomes fully commercial.

The reason for developing oxy-fuel power plants is to control the emission of carbon dioxide; however, conventional pollutants, such as nitrogen oxides and sulphur oxides, must still be considered. This thesis discusses the control of nitrogen oxides (NO_x) from oxy-fuel combustion. Nitrogen oxides originate from combustion processes: about half of the worldwide NO_x emissions come from the transport sector and about one-third from the power generating industry. When emitted into the atmosphere, nitrogen oxides contribute to the formation of acid rain, particles, smog and ground-level ozone, all dangerous to human health and environment. The first emission regulations to control the emission of nitrogen oxides were established in the early 1970's, and since then regulations have become increasingly stringent and emissions decreased. Today, the emission of nitrogen oxides is a crucial design parameter in the construction of all power plants.

Controlling NO_x emissions into the atmosphere is required but potentially also for CO₂ storage. In addition, it might be necessary to limit the level of NO_x in oxy-fuel power plants due to technical issues, such as the corrosion of materials. NO_x may be controlled during various parts of the process:

- A. In the furnace in order to reduce the formation of NO_x.
- B. In the flue gas recycle loop in order to limit the enrichment of NO_x in the furnace.
- C. During CO₂ conditioning in order to limit the concentration of NO_x in the stored CO₂ and/or in the ventilated gas.
- D. After CO₂ has been separated in order to limit NO_x in the ventilated gas.
- E. After the ventilated stream has been separated in order to limit NO_x in the stored CO₂.

Method A is called a “primary” measure, while methods B through E are “secondary” measures. The most common way to limit the emission of NO_x in state-of-the-art power plants are through primary measures that delay the mixing of fuel and oxidizer and limit combustion temperatures. These measures, however, also decrease combustion efficiency. The conditions inherent in the combustion process and flue-gas cleaning process differ between air and oxy-combustion. The conditions specific to oxy-fuel combustion, which are of importance for nitrogen chemistry, are listed in Table 1.1.

1.1 Aim of Research

The overall purpose of research on oxy-fuel combustion for CO₂ capture is to make the oxy-fuel fired power plant technology a commercially viable and competitive option for power generation on a market with CO₂ constraints. The work required is an extensive task which entails research in many areas, including oxygen production, combustion issues, heat transfer, and flue gas treatment. The scope of the present thesis is to investigate and suggest solutions whereby NO_x emissions from coal-fired oxy-fuel combustion may be controlled. The aim may be divided into three tasks:

Table 1.1. Principal changes from air to oxy-fuel combustion with respect to NO_x control in coal fired power plants (FGR = flue gas recirculation).

Relevant to primary measures	Relevant to secondary measures
Lowered concentration of N ₂	Increased pressure
Recycling of flue gases (NO _x)	Decreased temperature
Increased concentration of combustion products	Increased concentration of combustion products
Changed residence time (depending on FGR)	Reduced mass flow of gas
Changed temperature conditions (depending on FGR)	

- Compare the emission of NO_x under oxy-fuel conditions with conventional air-fired conditions to identify the important differences (Paper I).
- Investigate the importance of the recirculating NO_x , of the high concentrations of CO_2 and of the low concentrations of N_2 under oxy-fuel conditions, with respect to the two major reduction routes for NO_x : the reburning mechanism (Papers II and III) and the Zeldovich mechanism (Paper IV).
- Review the possibilities of NO_x control downstream of the combustion in an oxy-fuel power plant in order to compare with combustion measures (Paper V).

1.2 Content of the Thesis

This thesis is composed of an introductory essay and five appended papers. The purpose of the introductory essay is to summarize the work of the appended papers and to draw some broad and general conclusions thereof. Furthermore, aspects of the methodology and results of other research groups, which could not be included in the papers, are discussed. The essay has eight chapters divided into three separate parts.

Chapter 2 explains the methodology of the combustion modelling performed in the present work. Detailed reaction mechanisms for modelling nitrogen chemistry in combustion, as well as associated simplifications of the description of the geometry and mixing behaviour are presented and discussed. A short overview of the experiments performed in connection with this work is also included.

Chapters 3 to 7 present the findings of how to control nitrogen oxides in oxy-fuel power plants. Chapter 3 introduces oxy-fuel power plants, including a discussion on important differences between them and conventional plants in addition to NO_x limitations in the process. The results from other research groups involved with NO_x emission in oxy-fuel power plants are presented in Chapter 4, with a focus on recent findings. Chapter 5 discusses important mechanisms whereby NO_x is formed during coal combustion and relates those to the results of the present work. Then, measures and strategies for controlling NO_x during combustion and in the flue gas train of an oxy-fuel power plant are presented in Chapters 6 and 7, respectively.

Finally, the results are summarized in Chapter 8. The choice of control method depending on the maturity of oxy-fuel combustion is explained. Limitations and regulations involving NO_x are discussed, and overall conclusions and suggestions for follow up work are given.

2 - Methodology

The present investigation on NO_x in oxy-fuel combustion systems includes modelling (Papers I-IV) and experimental work (Papers I and III) as well as a review on primary and secondary measures for NO_x control in oxy-fuel power plants (Paper V). This thesis mainly deals with modelling of combustion and nitrogen chemistry. Two approaches are employed for modelling NO_x emissions: an aggregated simplistic combustion model (Paper I) and a detailed chemistry model (Papers I-IV). The aggregated combustion model is a tool whose purpose is to evaluate the coal fired experiments performed in connection to this work. This model has the advantage of describing the complete combustion chemistry, including heterogeneous and homogeneous reaction routes for formation and reduction of NO in air and oxy-fuel combustion. The objective is to determine the importance of decreased formation versus increased destruction on the total NO reduction in oxy-fuel combustion. This model should be regarded as descriptive rather than predictive. The detailed chemistry model is, on the other hand, a predictive model based on well established reaction kinetics from literature. In the present work, this model aims at further investigating the gas-phase reduction of NO during oxy-fuel combustion, under conditions that are not included in the experiments. The importance of reduction paths and of certain parameters is investigated to evaluate and design primary measures for NO_x control in oxy-fuel fired power plants.

These modelling approaches are described in detail in each paper. This chapter discusses critical modelling assumptions made that are not treated in the papers: the detailed reaction mechanisms applied in the present thesis are presented and compared with each other, and the plug-flow assumption and the influence of mixing are discussed. In addition, an overview of the experimental arrangement, which serves as input to the modelling work, is presented.

2.1 Detailed Reaction Mechanisms

In the detailed chemistry model the combustion and NO_x reaction process is modelled with several hundreds of elementary reactions but with simplified descriptions of the temperature profile and mixing behaviour. The reaction mechanism contains the kinetics of the reactions modelled. The construction of a detailed reaction mechanism includes thermodynamic calculations and fitting to

experiments performed under controlled conditions. This is a project that has been carried out by several research groups under long periods of time during which updated versions of the mechanism have been presented. In the present work, two generations of a reaction mechanism are used. Figure 2.1 presents an overview of the development of the mechanism, with major contributions and the most recent improvements illustrated. The work with this methane combustion mechanism, including its extensively tested and updated nitrogen chemistry, was initiated by Miller et al. (1981) at Sandia National Laboratories in the early 1980's. The Technical University of Denmark was involved at an early stage developing this reaction mechanism (Glarborg et al. 1986). The two versions of the mechanism used in this work are the version presented by Skreiberg et al. (2004) (hereafter referred to as DTU-04) (Papers I and IV) in addition to the version presented by Mendiara and Glarborg (2009a) (DTU-09) (Papers II and III). The DTU-04 mechanism is the ancestor of the DTU-09 mechanism. The major sources for updating the kinetic data include Dagaut et al. (2003), Glarborg and Bentzen (2008), Rasmussen et al. (2008a; 2008b; 2008c; 2008d), Gimenez et al. (2009), and Tian et al. (2009). Furthermore, the DTU-09 mechanism has been validated for the high levels of CO₂ achieved in oxy-fuel combustion (Glarborg and Bentzen 2008; Mendiara and Glarborg 2009a; 2009b), which is not case for the DTU-04 version.

To illustrate the differences between the two mechanisms used in this work, the NO reduction simulation of Paper III performed with both mechanisms is shown in Figure 2.2. Furthermore, results of the same simulation performed with the GRI-Mech 3.0 (Smith et al. 1999) mechanism from 1999, which is a well known and frequently used reaction mechanism, is presented for comparison purposes. This simulation exercise is not intended to evaluate the mechanisms but rather to illustrate the impact of these mechanisms on the achieved concentration profiles. The simulation has an inlet concentration of 500 ppm NO with the fuel and the oxidizer gradually being mixed. Fuel-bound nitrogen is not included. Details on inlet flows and temperature of the simulation are provided in Paper III.

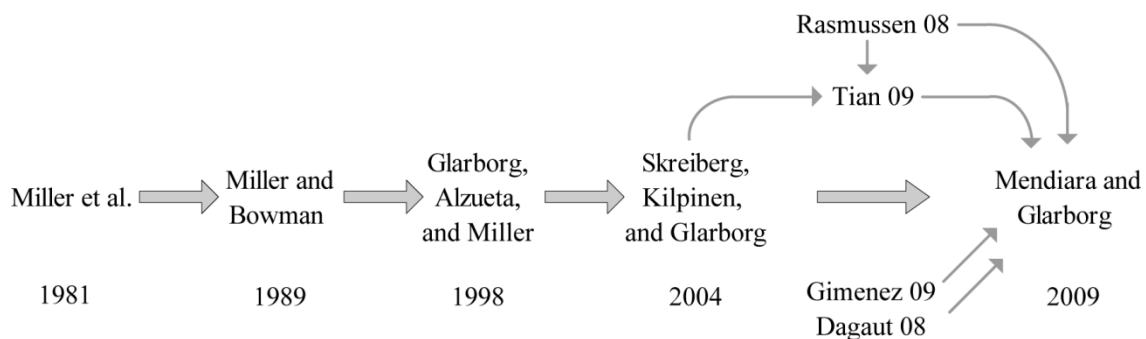

Figure 2.1. Evolution of the mechanism presented by Mendiara and Glarborg (2009a).

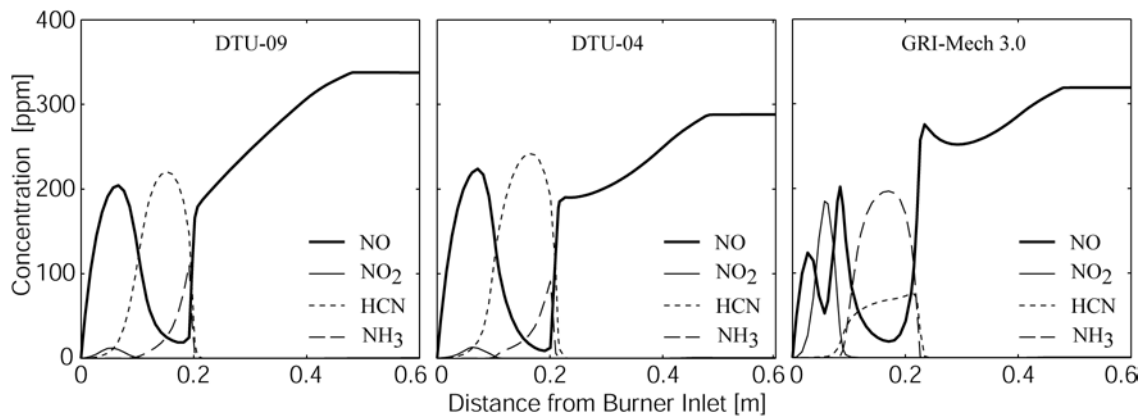

Figure 2.2. Comparison between the two versions of the mechanism used in the present work (left and centre) and the GRI-Mech mechanism (right). Solid lines denote NO_x and dotted lines intermediate nitrogen species. Fuel-bound nitrogen is not included in the simulation. The inlet NO concentration is 500 ppm and fuel (CH_4) and oxidizer (O_2/CO_2) is gradually mixed during the first 0.5 meters from burner inlet. The simulations are based on the methodology in Paper III.

The concentration profiles of NO, NO_2 , HCN, and NH_3 generated by the three mechanisms are illustrated in Figure 2.2 in order to compare their relative performance. All three mechanisms predict similar outlet concentrations of NO (around 300 ppm). However, the GRI-Mech simulation differs from the DTU simulations in the two areas: the large formation of NO_2 in the early parts of the flame, and the domination of NH_3 over HCN as an intermediate nitrogen species and NO_x precursor. Both observations are critical to nitrogen chemistry, but they are also unexpected. The GRI-Mech mechanism is not considered for describing the system investigated and the reasons for the discrepancy are not further examined in this work. As indicated above, DTU-09 is an update of DTU-04 and the two are, therefore, expected to generate similar results, which is the case. The largest deviation is attributable to the accumulation of NO from 0.2 to 0.5 meters from the burner inlet where the DTU-04 calculation shows a smaller increase, resulting in a 15% lower calculated emission. This deviation is due to updated third-body efficiencies for H_2O , O_2 , H_2 and CO_2 of the recombination reaction between H and NO to HNO in the DTU-09 mechanism.

The work presented in this thesis, based on the DTU-04 mechanism, mainly focuses on high-temperature reduction of NO, in which the Zeldovich mechanism is of great importance. For DTU-09, the reaction rate of the reaction between atomic nitrogen and hydroxyl radicals in the extended Zeldovich mechanism is updated to be temperature independent upon the recommendations of Baulch et al. (2005). There are, however, uncertainties about which reaction rate to apply, as discussed by Tian et al. (2009). The reaction rate in DTU-04 is 1.3 to 1.6 times higher (depending on temperature) than the rate applied to DTU-09. Figure 2.3 presents a simulation of the reduction of 1000 ppm NO during combustion under conditions favourable for high-temperature NO_x reduction (temperatures decreasing from 2000°C to 1800°C and relative long residence time). The choice of reaction rate is of marginal importance to the results obtained.

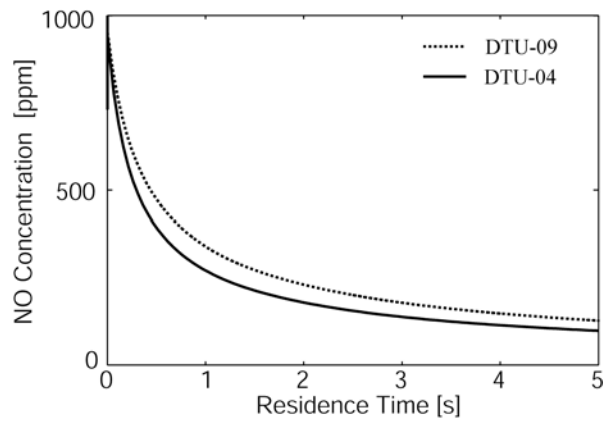

Figure 2.3. Comparison between DTU-04 and DTU-09 under conditions favourable to high-temperature NO_x reduction. The inlet NO concentration is 1000 ppm with temperatures decreasing from 2000°C to 1800°C. The simulations are based on the methodology of Paper IV.

2.2 Reactor and Mixing Assumptions

To describe industrial flames and combustion systems requires a comprehensive approach employing computational fluid dynamics (CFD), which includes detailed modelling of turbulent flow, heat transfer and reaction kinetics. However, due to the complexity and close interconnection between these processes, assumptions narrowing the validity range of a CFD model are often unavoidable, and it is difficult to investigate an isolated combustion phenomena. Furthermore, the long computational time required makes it time-consuming to run a broad set of parameters. For investigations on NO_x emission, especially involving new reduction methods and combustion environments, it has proven useful to focus on nitrogen chemistry and instead use simple descriptions of the mixing behaviour and reactor. There are two ideal reactor types often applied, the continuously stirred tank reactor (CSTR) and the plug-flow reactor (PFR).

The ideal CSTR and PFR are each other's opposites in that the CSTR assumes perfect mixing throughout the entire volume, while the PFR assumes no mixing in the direction of the flow but perfect mixing perpendicular to the flow. An infinite amount of small CSTRs makes up a PFR. During combustion, limited turbulent zones with a high degree of back mixing could be approximated by a CSTR, while zones with a relatively high forward velocity would be better represented by a PFR. In either way, the application of an ideal reactor is a severe simplification of the combustor, as discussed above. The key negative effects of perfect mixing assumptions of importance to combustion modelling are that the reaction rate might be overestimated if mixing rates are too low, and that the recirculation of product might lower concentration of reactants and affect the residence time.

Figure 2.4 compares the influence of the applied mixing assumption on the results of reburning and high-temperature reduction. Reburning is highly dependent on mixing assumptions. With the ideal plug-flow assumption, hydrocarbons are

rapidly oxidized and the radicals, which reduce NO, are only present for a short period of time with a resulting minor reduction. In the CSTR, the concentration of radicals is constant throughout the entire volume, and the reduction is, therefore, increased. Also, with delayed mixing between fuel and oxidizer in the PFR, the period of time when radicals are present is extended and a further reduction achieved. Under oxygen-rich conditions ($\lambda > 1$), the delayed mixing still creates an oxygen-lean zone with a better performance compared to other reactors. The high-temperature reduction, on the other hand, is not dependant on reducing agents or combustion progress. Instead, the key parameter is a sufficiently high temperature for reactions to occur, resulting in a marginal dependence on the mixing assumption, as shown on the right-hand side of Figure 2.4. The discrepancy for oxygen rich conditions is attributable to the higher relative importance of the reburning reduction, in which the reduction is higher in the mixed PFR and CSTR.

Mixing has previously been proven important to the qualitative evaluation of reburning reactions as the ideal plug-flow assumption tends to underestimate the reduction of NO (Kilpinen et al. 1992). A commonly applied method to simulate mixing, with a good performance record, is gradually introduction of the reburning fuel into the generated flue gas, or vice versa (Kilpinen et al. 1992; Rota et al. 1997; Alzueta et al. 1998). In the present investigation, a mixed PFR is applied in Paper III, in which a reburning reduction is investigated and compared to experimental measurements. The oxidizer containing NO is gradually introduced into the fuel stream. In Paper II, which investigates reburning chemistry, the initial concentrations of fuel and oxidizer are heavily diluted by combustion products in another attempt at simulating the effects of mixing. The investigations of high-temperature NO_x reduction in Papers I and IV are performed with a PFR assumption. This reactor has the advantage of being simple while at the same time providing results with a time resolution.

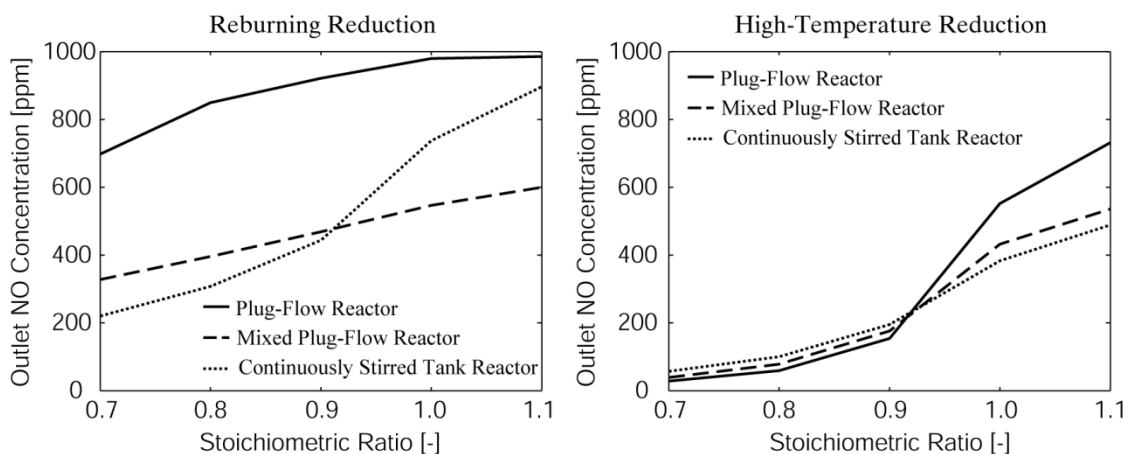

Figure 2.4. Comparison between mixing assumptions for the prediction of reburning reduction (left-hand side) and high-temperature reduction (right-hand side). Conditions for reburning reduction and high-temperature reduction are described in connection to Figure 2.2 and Figure 2.3, respectively.

2.3 Overview of the Experimental Arrangement

The fuels investigated in the experimental work connected to the present thesis are coal (lignite) and propane. In the gas-fired experiments, the effect of oxy-fuel conditions on nitrogen chemistry during combustion was studied without the interference of fuel-bound nitrogen and heterogeneous effects. The coal-fired experiments complement these results by providing a more realistic representation of a commercial application.

Figure 2.5 presents a flow chart of the experimental facility. All experiments have been performed in the Chalmers 100 kW oxy-fuel test unit, employed since 2003. The test unit is a down-fired furnace capable of operating under conventional air-fired conditions, as well as under oxy-fuel conditions. The burner is a dual-register swirl-burner. Similar oxidant registers are used for both the gas and the coal. Under oxy-fuel conditions, operations involving either dry or wet flue-gas recycling have been feasible; however, in present experiments only dry flue-gas recycling has been employed. Oxygen (99.5% purity) has been mixed into the recycled flue gas to achieve the desired concentration in the oxidizer. Furthermore, NO could be injected into the oxidizer in order to design experiments targeted on NO reduction. The oxidizer has been divided into a primary and a secondary stream in the burner. Out of the total feed-gas flow, roughly 30% enters the primary stream and the remaining part is fed into the secondary stream. It is also possible to introduce oxygen downstream of the burner (800mm from burner inlet), comparable to over-fire air, to be able to operate the burner under sub-stoichiometric conditions, something which is done in the gas-fired experiments.

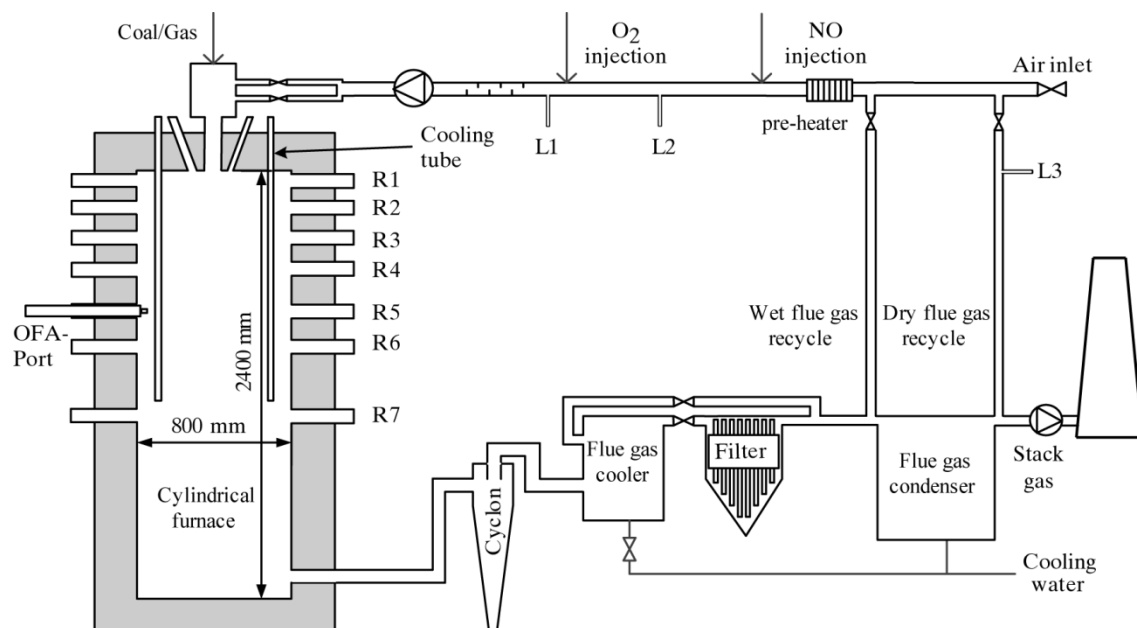

Figure 2.5. Flowchart of the experimental unit. R1 to R7 and L1 to L3 are measurement ports in the reactor and recycle loop, respectively. OFA = Over-fire air.

The composition and temperature measurements have been carried out in the combustor and recycle loop to investigate combustion chemistry and global nitrogen balance. Radial profiles are recorded inside the furnace through seven measurement ports located alongside the reactor from 46 to 1400 mm from the burner inlet. Concentrations of CO₂, CO, O₂, NO and total hydrocarbons are continuously measured during experiments. For some of the test runs, the concentration of NH₃, HCN and NO₂ are also measured. Furnace temperature profiles are measured by means of a suction pyrometer.

A fuel input of around 80 kW is used during all experiments. The overall stoichiometric ratio is kept constant at 1.15 in propane-fired tests and at 1.18 in lignite-fired tests. In gas-fired experiments, NO is added to the recycled flue gases in amounts sufficient to maintain a constant inlet NO concentration of 500 ppm. A parameter study of the inlet oxygen concentration and stoichiometric ratio is performed. In the propane-fired experiments, the burner stoichiometry varies from 0.7 to 1.15. The oxygen concentration of the oxidizer varies between 25% and 37% and between 25% and 29% in propane and lignite firing, respectively.

3 - Oxy-Fuel Power Plant Technology

Figure 3.1 is a schematic of an oxy-fuel power plant. Oxygen mixed with recycled flue gas replaces combustion air to eliminate the large amount of nitrogen present in the air. This generates a flue gas that mainly consists of carbon dioxide and water vapour, which are easily separated from each other. The separated carbon dioxide is cleaned, compressed and cooled before being transported to storage. The most cost-effective technology currently available for oxygen production of the quantity and quality (>95% purity) needed is cryogenic air separation. The oxygen production and flue-gas/CO₂ compression are the major sources of energy penalty compared to an air-fired plant. The combustion and flue-gas treatment of an oxy-fuel power plant are discussed in more detail below, although feed-stock systems (e.g. air-separation and coal preparation), and systems for transport and storage of carbon dioxide are not treated in the present study.

The design of oxy-fuel power plants may be divided into two generations. A first generation will, as far as possible, use technology proven in air-fired power plants in order to achieve a rapid and secure introduction of the oxy-fuel technology. In the first generation, the operational data of oxy-combustion are controlled to mimic air combustion, and conventional flue-gas cleaning equipment is used. In a second generation, the possibility to use innovative techniques is higher and new parameters available to optimize oxy-fuel combustion may be utilized to find new ideal operational conditions. For example, the possibility to control the concentration of oxygen in the oxidizer (not possible in air combustion) might lead to new optimal operating conditions. Furthermore, the second generation

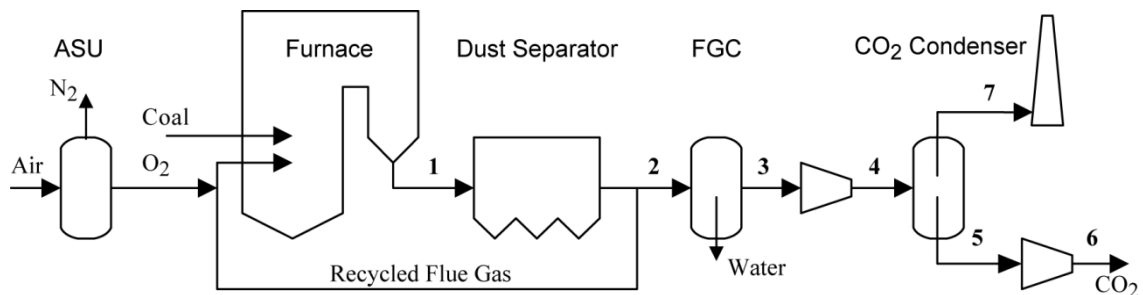

Figure 3.1. Principles of an oxy-fuel power plant with wet flue gas recirculation. FGC = flue gas condenser, ASU = air separating unit.

oxy-fuel power plants may be designed when the capture and storage of CO₂ has become an established part of the energy system and legislation involving oxy-fuel conditions have been instituted.

3.1 Oxy-Fuel Combustion

The oxy-fuel combustion, including the boiler, is central to the design of a power plant. Fuel and oxidizer, consisting of oxygen diluted by recycled flue gases, are introduced into the furnace where the fuel is burnt. The heat generated produces steam in the boiler and the flue gas leaves the boiler at a temperature of around 200°C. The flow of recycled flue gas controls the properties of the combustion process, including temperatures, burner aerodynamics, and gas residence time. As mentioned, the first generation of oxy-fuel boilers will imitate the behaviour of air-fired boilers. This is achieved at an oxygen concentration of around 30% in the oxidizer and a large fraction (around 2/3) of flue-gas recirculation. Prior to recycling, particles are separated from the flue gas to limit enrichment in the loop and furnace and to prevent such conditions as fouling.

Water is separated from the flue gas by condensation. Generally, it would be preferred to recycle wet flue gases, i.e. prior to condensation. The wet-recycle is thermodynamically superior to dry-recycle of flue-gas, which is extracted downstream of the condensation (the temperature being determined by the dust separator temperature as apposed to the condensation temperature). Dry recycle would be required if there are restrictions on the level of moisture or SO₂ in the recycled flue gas, which for example is the case for feeding coal.

For safety reasons, pulverized fuel boilers often operate at slight sub-atmospheric pressure. Besides oxygen purity, air ingress is an important source of impurity in the CO₂, and in oxy-fuel combustion, air ingress requires extra consideration to minimize the cost for conditioning of the CO₂. To avoid air ingress the oxy-fuel boiler could be made gas-tight or slightly pressurized. However, complete elimination of air is difficult as there are still possibilities for air ingress in, for example, the particle separation, the recycle fan, and the coal feeding system.

3.1.1 Influence of CO₂

The replacement of N₂ by CO₂ and H₂O has important implications on the combustion process, including lower temperature (due to higher heat capacity), and lower flame propagation velocity (due to lower diffusivity). Besides these properties, N₂ is, in principle, transparent to thermal radiation and the gas emissivity is increased in an environment of elevated concentrations of CO₂ and H₂O, which affects the heat transfer in the boiler.

Carbon dioxide and water vapour are more reactive than N₂ and will more actively participate in the combustion process. For example, water is known to

react with char at a rate close to the one of oxygen at temperatures above 1200°C (Wu 2005). Furthermore, the influence of the oxy-fuel environment on char gasification by CO₂ is discussed; some investigations claim that CO₂ will enhance the burnout of the coal (Shaddix and Murphy 2003; Toporov et al. 2008; Li et al. 2009; Rathnam et al. 2009), while others consider CO₂ to be of marginal or no importance (Liu et al. 2005; Mackrory 2008; Liu 2009).

In addition the homogeneous combustion chemistry is affected by an increase in CO₂ concentration. It has been concluded (Liu et al. 2001) that the reaction,



which produces most of the CO₂ during combustion may be reversed by the elevated concentration of CO₂ in an oxy-fuel flame. This will, in turn, impact the concentration of hydrogen radicals and the crucial chain branching reaction between hydrogen radicals and oxygen,



which could lead to slower oxidation of the fuel and lower flame velocity during oxy-fuel combustion than during air combustion. When CO starts to oxidize into CO₂ (the forward Reaction (3.1)) the higher CO concentration in oxy-fuel combustion reduces the relative rate of consumption of radicals and, eventually, the concentration of radicals in oxy-fuel combustion could exceed that of air combustion. The relative order of the quantity of radicals may change from H>OH>O in air combustion to OH>O>H in oxy-fuel combustion, which is of significance to the combustion chemistry related to hydrocarbon oxidation, nitrogen oxides, and soot formation.

3.1.2 Influence of Recycle Ratio or O₂ Concentration

New opportunities to control and optimize the combustion process are also present in oxy-fuel combustion as a consequence of the composition of the oxidizer. Figure 3.2 illustrates the effects of O₂ concentration on the adiabatic flame temperature and the total volume flow through the reactor for methane oxy-fuel combustion (in CO₂). The volume flow is presented both independently of temperature and at a temperature variation corresponding to the change in adiabatic flame temperature. The adiabatic flame temperature for methane in air is 1950°C, corresponding to around 30% of O₂ in oxy-fuel combustion. The higher oxygen concentration reduces the mass flow through the furnace and downsizes the furnace and equipment within the recycle loop. Furthermore, higher concentrations of O₂ increase the combustion velocity and decrease the ignition temperature. Besides the concentration of O₂, the water concentration in the oxidizer could also be adjusted by choosing between wet and dry recycle. Dry recycle enhances the concentration of the species present in the RFG.

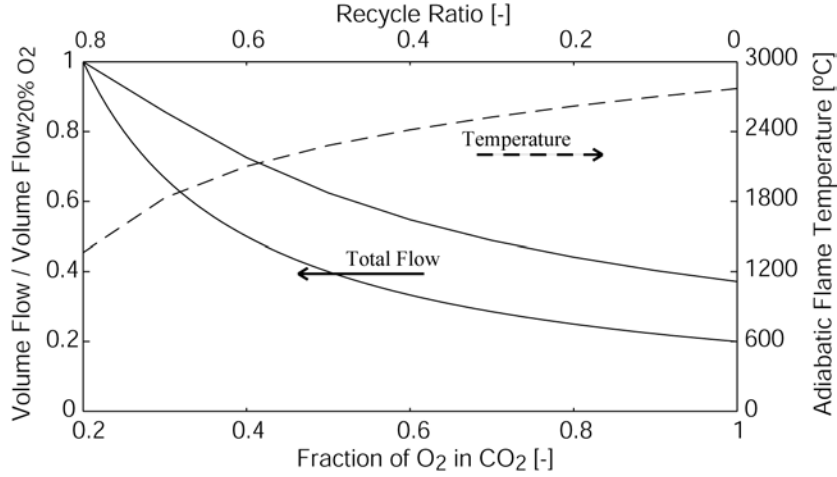

Figure 3.2. The influence of O₂ concentration for an adiabatic equilibrium methane O₂/CO₂ flame at constant atmospheric pressure, inlet gas temperature 25°C and $\lambda = 1.1$. Left: Flow at constant temperature (lower curve) and at the adiabatic temperature corresponding to the oxygen concentration (upper curve), respectively. Right: Adiabatic flame temperature as a function of oxygen concentration. Ref: Paper IV.

The recycle of flue gases influences the process by re-exposing species contained in the gas to the flame, thereby increasing the residence time in the reaction zone compared to air-firing. In oxy-fuel combustion, the once-through residence time of gas in the furnace (τ_{once}) must be distinguished from the effective residence time (τ_{tot}), which is the cumulative residence time depending on the number of times the gas passes through the furnace. For isomolar combustion, this may be calculated as the total flow through the furnace divided by the inlet flow of gas (excluding the recycle), which is illustrated by the following relationships,

$$\tau_{once} = \frac{V_C}{F_{O_2} + F_I + F_{RFG}} \quad (3.3)$$

$$\tau_{tot} = \frac{F_{O_2} + F_I + F_{RFG}}{F_{O_2} + F_I} \tau_{once} = \frac{V_C}{F_{O_2} + F_I} \quad (3.4)$$

in which F_{O_2} is the volumetric flow of oxygen, F_I the flow of other gases introduced with the oxygen (mainly N₂ and Ar), and F_{RFG} the flow of recirculated flue gas through the volume of the combustion chamber (V_C). For oxy-fuel combustion, F_I approaches zero (after having been around four times F_{O_2} in air combustion), and total residence time is significantly increased under otherwise similar conditions. Total residence time is most critical to nitrogen chemistry, and the once-through residence time (or volume) has a subordinate impact on NO_x reduction and the reactor volume could, therefore, be reduced in the design of an oxy-fired furnace. The combustion process depends, however, on the once-through residence time, which is also affected by the amount of RFG (or oxygen concentration), Equation (3.3). As previously discussed, in oxy-fuel combustion of the first generation, the O₂ concentration in the oxidizer is set to around 30%,

which results, as intended, in similar furnace volumes for air and oxy-fuel combustion.

3.2 Flue-Gas Train

The purpose of the flue-gas train in an oxy-fuel power plant differs from that of an air-fired plant. In an oxy-fuel plant, the focus is on CO₂ conditioning rather than on the treatment of the vented gas to fulfil current regulations on harmful emissions. The separation processes required are similar to the processes found in a flue-gas train of a conventional air-fired power plant, although conditions and requirements of the final product may differ. Figure 3.1 includes an outline of the oxy-fuel flue gas train including the definitions of the streams used in the present work.

As discussed above, particles are separated from the flue gas prior to recycling by conventional techniques. The main part of the water is separated from the flue gas in the flue-gas condenser (FGC). However, water has to be removed to ppm levels for the continued processing of CO₂ and the condensation is combined with an adsorption process. The flue gas is compressed and cooled in stages until the CO₂ is liquefied. The liquefaction takes place at a pressure between 15 and 40 bar and at a temperature between -20°C and -55°C, depending on process conditions. After liquefaction, the CO₂ is compressed to supercritical conditions for cost-effective transportation and storage.

For typical design parameters (oxygen purity and combustion operation), the exhausted flue gas (from combustion) consists of around 95% CO₂ on a dry basis. The remaining part is primarily made up of excess oxygen from combustion, nitrogen and argon from impurities in the oxygen, and, to a lesser extent, pollutants, such as nitrogen oxides and sulphur oxides (0.1 to 0.2%). Air ingress and oxygen quality are important parameters to limit the amount of impurities. Air ingress may lower the CO₂ concentration to below 95%. The CO₂ purity requirement is not clearly defined in carbon capture and storage schemes (to be further discussed below), and the level of emission control required in the oxy-fuel flue gas train is, therefore, unknown. The CO₂ liquefaction process separates most of the O₂, N₂ and Ar, which are not condensed but vented into the atmosphere under the given conditions. The design of pollutant control (i.e. NO_x, SO_x and mercury removal) is an ongoing discussion and is likely to assume new directions as the process matures.

3.2.1 Influence of CO₂ Conditioning on Nitrogen Chemistry

The possibilities of controlling NO_x in the flue gas train of an oxy-fuel power plant are summarized in Chapter 7. This chapter discusses differences of importance to the emission of nitrogen oxides compared to air-fired power plants. The reduced mass flow (elimination of N₂), high pressure and low

temperature, which all contribute to drastically reduce the volume flow throughout the flue gas train is a key effect. Figure 3.3a illustrates the relative change in volume flow throughout the oxy-fuel flue gas train compared to air-fired plants. The flow is already lower to begin with due to the higher oxygen concentration in the oxidizer and is, thereafter, heavily reduced after being separated from the recycle stream, and in parts of high pressure. As a consequence, the later the NO_x reduction is performed in the flue-gas train, the smaller the flue-gas volume to be treated; with the size of the treatment equipment being correspondingly reduced.

The elevated pressure and low temperature required in the CO_2 condenser also affect the chemistry of importance to NO_x control. The oxidation of NO into NO_2 by the O_2 present in the flue gas, follows the reaction

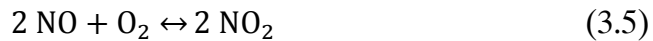

which is favoured by a low temperature and high pressure. Figure 3.3b illustrates the oxidation of NO into NO_2 in a flue-gas stream at representative pressures, calculated with the reaction scheme of Skreiberg et al. (2004). Downstream of the compressor (Stream 4 in Figure 3.1), the pressure is sufficient (around 30 bar) for a large part of the NO to be converted into NO_2 within the flue-gas train, something that is not feasible in air-fired power plants. NO_2 can be controlled by other techniques than those available for NO and new reduction measures may emerge (to be further discussed in Chapter 7).

3.3 Limitations for NO_x in Oxy-Fuel Power Plants

An oxy-fuel power plant has two outlet streams: the vent stream emitted, and the CO_2 -rich stream to be stored. Although there is no clear regulation at present, the amount of NO_x allowed in the two streams should be limited. Such a

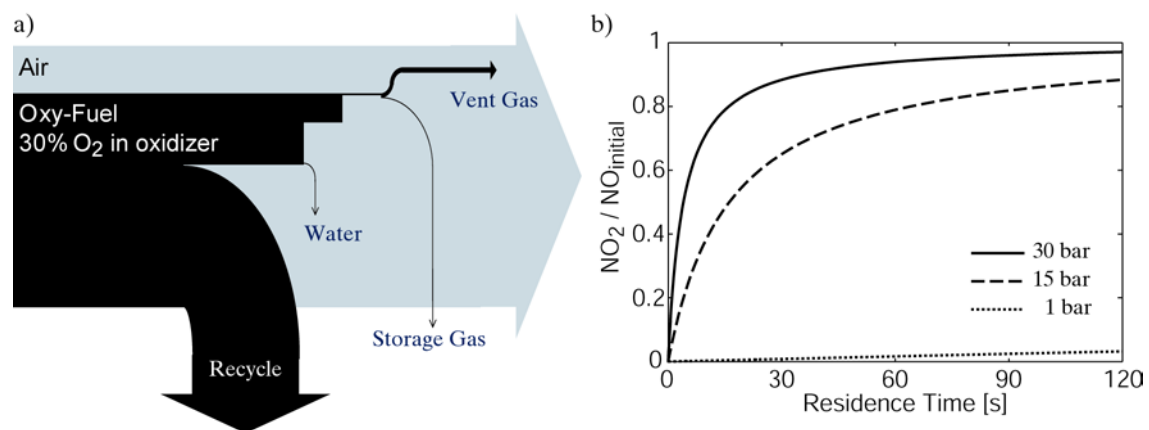

Figure 3.3. Important implications of oxy-fuel combustion on flue-gas treatment. a) Influence of pressure on the conversion of NO to NO_2 ; $\text{NO}_{\text{initial}} = 400$ ppm and, $\text{O}_{2, \text{initial}} = 3\%$, temperature = 20°C . b) Sankey diagram of the volume flow in an oxy-fuel flue gas train compared to that of a conventional air-fired plant. Ref: Paper V.

regulation can be based on environmental requirements or on best available techniques (BAT) (Sloss 2003). The environmental approach is supported by factors such as air quality or critical load that address human or ecological concerns. These factors are then associated with sources of emission to meet the desired targets. The BAT approach to emission legislation is based on an assessment of available techniques for emission control. As the control techniques are developed, the limit is lowered over time. BAT is defined in the EU directive for integrated pollution prevention and control (EU 2008). Furthermore, NO_x is an acid gas which may be necessary to control, not only for environmental reasons, but also to limit corrosion issues.

3.3.1 Vent Stream Limitations

The emission of NO_x into the atmosphere has been a major environmental concern since the beginning of the 1970's. Today regulations on emission levels have been adopted worldwide (Sloss 2003). Emission limits are often defined as being synonyms with concentration limits (e.g. in Europe as mg/Nm^3 flue gas (EU 2009)). In oxy-firing, nitrogen is excluded from the combustion and the flue-gas volume (Nm^3) is decreased by around 80% compared to air-firing. Furthermore, the principal part of the flue gas is extracted for storage and only around 10% of the flue gas generated is emitted into the atmosphere. Thus, the same pollutant formation as in air combustion generates higher concentrations of pollutants in oxy-fuel combustion. Figure 3.4 shows the relative increase in emission from air to oxy-fuel combustion with the same pollutant formation. Thus, emission limits that are based on flue gas concentrations from air-firing are not comparable to those of oxy-firing without making required adjustments. Standards based on emission per unit of energy produced (e.g. g/GJ electricity), which encourages emission reductions through efficiency improvements, are enacted by means of US legislation. The energy penalty currently associated with oxy-fuel combustion

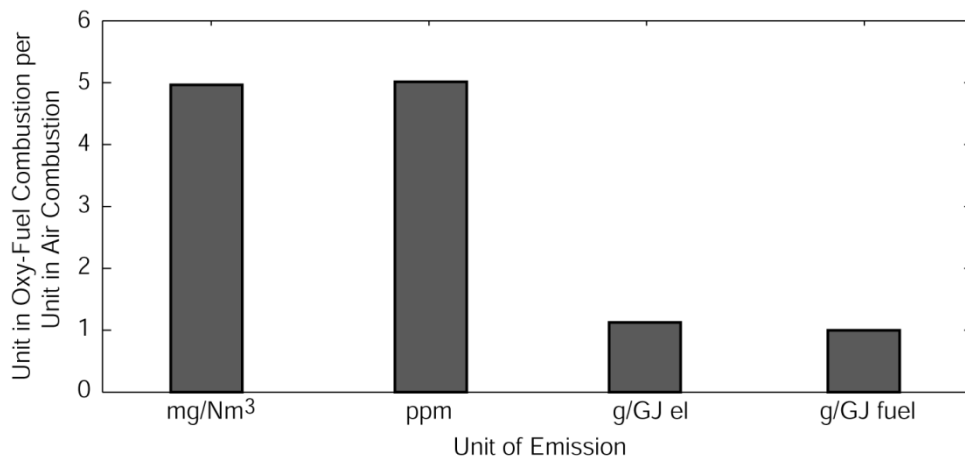

Figure 3.4. Relative increase in emission under oxy-fuel conditions compared to air-fired conditions depending on unit. The pollutant formation is constant. Conditions: dry flue gas, 6% excess O_2 , $350 \text{ m}^3/\text{GJ}_{\text{fuel}}$ (Air), $70 \text{ m}^3/\text{GJ}_{\text{fuel}}$ (Oxy-fuel), thermal efficiency 0.45 Air and 0.4 Oxy-fuel.

will increase the emission by around 20% per unit of energy produced compared to a corresponding air-fired unit. The emission per unit of fuel supplied (e.g. mg/MJ fuel) is similar, but is not affected by the efficiency of a power plant. Correspondingly, if a comparison between processes were to focus on emissions alone, the latter unit would be preferred.

If current EU regulations for NO_x emission from large combustion plants of 200 mg/Nm³ were to be converted to oxy-fuel conditions where emissions per energy supplied or produced were to be kept constant, the regulation limit for oxy-fuel combustion would be 1000 mg/Nm³ (487ppm) or 890 mg/Nm³ (433 ppm), respectively (these figures are calculated for furnace outlet before CO₂ separation). If environmental requirements were considered, emission limits based on emission per unit of energy produced would be appropriate because emissions into the atmosphere would be kept constant (assuming the demand for energy would be constant). However, employing BAT, the constant concentration (e.g. mg/Nm³) would probably be more appropriate, because concentration is a key parameter for most reduction measures and because an oxy-fuel power plant includes new, efficient options for NO_x control, as discussed in this work.

3.3.2 Storage Gas Limitations

The purity requirement of storage gas is not an emission limit in the same sense as the limit applied to stack gas-emissions. The international legislation against dumping/storing of waste was updated in 2006 to allow for storage of CO₂ according to an amendment added to the London Convention Protocol on waste dumping in marine areas [17] and by a similar amendment to the OSPAR Convention on the protection of the North-East Atlantic in 2007 [18]. Both conventions state that the storage gas should consist “overwhelmingly” of CO₂. In 2009, the European Union issued a directive on the geological storage of CO₂ (EU 2009) by stating that:

“A CO₂ stream shall consist overwhelmingly of carbon dioxide. To this end, no waste or other matter may be added for the purpose of disposing of that waste or other matter. However, a CO₂ stream may contain incidental associated substances from the source, capture or injection process and trace substances added to assist in monitoring and verifying CO₂ migration. Concentrations of all incidental and added substances shall be below levels that would:

- (a) adversely affect the integrity of the storage site or the relevant transport infrastructure;*
- (b) pose a significant risk to the environment or human health; or*
- (c) breach the requirements of applicable Community legislation.”*

This declaration may be interpreted as to sanction the dumping or co-storage of NO_x (and other combustion generated pollutants) together with the captured CO_2 . However, no quantitative limits were defined. The feasibility of co-storing NO_x together with the CO_2 depends on the knowledge of reservoir mechanics and geochemistry as well as the public acceptance of NO_x storage. A great deal of work is being done to determine these limits, as discussed in a review by Bachu [19]. However, the concentration of NO_x is seldom mentioned as important and is hardly ever the main focus of these investigations. The one exception is a report by Taber (1985) on the fate of acid gases when injected with CO_2 for the purpose of enhanced oil recovery (EOR), which reports on experience with CO_2 injection and storage performed as early as 1924. The issues related to NO_x storage are principally connected with equipment corrosion.

3.3.3 Corrosion Limitations

As discussed, the oxidation of NO to NO_2 increases in high pressure parts of the oxy-fuel flue gas train. In contact with water, NO_2 forms nitric acid (HNO_3), and, furthermore, NO_2 has been proposed capable of catalysing the formation of sulphuric acid (H_2SO_4) from SO_2 . Both nitric and sulphuric acid are highly corrosive and damaging to process equipment even in small amounts. The experience of NO oxidation and acid formation in the flue gas train is limited; hence, it is difficult to estimate its consequences.

The experience of acid formation in flue gases mainly involves condensation of sulphuric acid, formed during the combustion. Sulphuric acid is formed at temperatures below its dew point (120 to 150°C). The amount of gaseous H_2SO_4 in the flue gas is limited (below 20 ppm); however, since H_2SO_4 has a dew point above water, high concentrations of acid (70% H_2SO_4) may form on local surfaces when H_2SO_4 starts to condense. Measures to resist corrosion usually include such actions as using: thicker materials, alloys, non-metallic coatings or non-metallic materials. If the mechanism for nitric and sulphuric acid formation at high pressures were active, this process would have the potential of forming thousand to ten thousand times more acid than the amount formed during combustion. An economic optimization study should be undertaken of measures to control acid formation and the capability of equipment to resist corrosion. It should be noted that the acid formation in this case will take place in the compressors, with obvious issues with corrosion in the absence of appropriate design measures.

4 - Research on NO_x in Oxy-Fuel Combustion

Extensive research on the oxy-fuel combustion process for CO₂ capture has been performed since the beginning of the 1990's and from the beginning, NO_x emissions have been included. This summary will divide previous research into “early” and “recent” work. The early work was carried out until around year 2005, and often consists of engineering studies, investigating the general features of oxy-fuel combustion and comparing it against air-firing. Much of this early work was performed in relatively large-scale test-units (up to 2.5 MW thermal). The recent work is mainly focused on understanding underlying reaction routes and mechanisms and attempts to better isolate the differences compared to air firing to be able to scale up and optimize oxy-fuel combustion.

4.1 Early Work

Much of the early work on NO_x in oxy-fuel combustion was performed by Japanese researchers: Nakayama et al. (1992), Kimura et al.(1995), Kiga et al. (1997), Nozaki et al. (1997), Okazaki and Ando (1997), and Hu et al. (2000; 2001; 2003). The investigations by these researchers include a semi-industrial-scale oxy-fuel combustion test unit, 1.2 MW (thermal), but also smaller lab-scale units to examine fuels and operating conditions. In Europe comprehensive early studies were conducted under the leadership of the International Flame Research Foundation (IFRF) (Woycenko et al. 1995) and within the EU Joule II Programme, (Allen 1995). This research operated a semi-industrial-scale test unit for oxy-fuel combustion (2.5 MW thermal) in combination with smaller units. A series of different coals and operating conditions were examined and the experimental investigation was complemented by a modelling study. The third pioneering work on oxy-fuel combustion and NO_x formation was conducted by the Canadian research centre Canmet (Croiset and Thambimuthu 2001; Chui et al. 2003; Zheng and Furimsky 2003; Chui et al. 2004; Tan et al. 2006). Canmet operated a 300 kW (thermal) oxy-fuel unit and performed a series of tests with different fuels, operating conditions and burner configurations. These investigations also included modelling and comparisons between experiments and CFD calculations.

The early work led to a consensus within the oxy-fuel research community that the emission of NO_x in oxy-fuel combustion per unit of fuel supplied is reduced

compared to air-firing and that this reduction is mainly caused by reduction of recycled NO_x into N_2 . The most commonly cited work is performed by Okazaki and Ando (1997), in which the reason for the reduced emission of NO_x within oxy-fuel combustion compared to air combustion was presented with the conclusion that for the NO_x reduction:

- 50-80% is caused by reduction of recycled NO,
- 10-50% is caused by interactions between recycled NO and fuel-bound nitrogen, and
- < 10% is caused by the effects of increased CO_2 concentrations.

4.2 Recent Work

More recently, the interest in oxy-fuel combustion and related nitrogen chemistry has been growing with work undertaken by research groups all over the world. Examples include: Park et al. (2005), Kim et al. (2007), Cao et al. (2009), Kaß et al. (2009), and Giménez-López et al. (2010). In this summary, three research groups have distinguished themselves for their contributions to the understanding of the NO_x formation mechanisms in oxy-fuel combustion:

1. Brigham Young University (BYU), whose work is summarized in the thesis by Mackrory (2008).
2. Institute of Process Engineering and Power Plant Technology (IFK formerly IVD) at University of Stuttgart with the main part of the work summarized in a thesis by Dhungel (2009) and presented in various conference papers, for example Maier et al (2006; 2007b; 2007a) and Mönckert et al. (2007a).
3. Technical University of Denmark (DTU) and the work performed by Glarborg and his co-workers (Glarborg and Bentzen 2008; Mendiara and Glarborg 2009a; Mendiara and Glarborg 2009b).

Below follows a presentation of the material published by the research groups 1 to 3 above, which is of key interest to the results presented in this thesis.

4.2.1 Brigham Young University

The work of the BYU group covers both homogeneous and heterogeneous reaction paths of importance to nitrogen chemistry and is performed through a combination of experiments and modelling. The experimental unit is a laminar flow reactor with possibilities for in-furnace gas and char sampling. There is no recycling of flue gases. Instead, bottled O_2 and CO_2 simulate oxy-fuel conditions. NO is also injected into the flue gas stream to investigate the reduction of recycled NO_x . The fuel is coal (two highly-volatile bituminous coals and one sub-bituminous coal) mixed with natural gas (the coal to gas ratio is about 1:1 in thermal input based on the higher heating value).

The model is constructed by existing sub-models available in the literature. The reactor is described as a plug-flow reactor divided into a series of steps and does not include fluid mechanics. Each reactor step includes separate models for homogenous and heterogeneous reactions linked together. The homogenous chemistry is described by the GRI 3.0 mechanism (briefly discussed in Chapter 2) up-dated with the advanced reburning reactions from Bowman (1997). The heterogeneous model includes a description of devolatilization, as well as char oxidation and gasification by CO_2 . Furthermore, furnace heat transfer is modelled. The main issue with the model is that it fails to describe, the formation of hydrocarbons and, thus, reburning of NO_x .

The BYU investigation draws the following conclusions:

- In unstaged combustion, the conversion of fuel-bound nitrogen to NO is similar in air and oxy-fuel combustion; however, during staged combustion, oxy-fuel conditions yield lower conversions.
- The importance of CO for NO_x reduction is stressed; the increased CO concentration in oxy-fuel combustion is explained by the thermodynamic equilibrium and the thermal dissociation of CO_2 . The gasification of char is shown to be of minor importance to increased concentrations of CO.
- Oxy-fuel combustion is reported to be less sensitive to the stoichiometric ratio and to have higher optimal stoichiometric ratio with respect to NO_x emissions than air combustion. This is mainly attributable to the onset of thermal NO_x formation in air firing when more O_2 is available in the primary combustion zone.

4.2.2 University of Stuttgart

The work presented by IFK is a comprehensive experimental investigation that examines homogeneous and heterogeneous reactions, staged and unstaged combustion, the location of NO injection, and coals of different ranks (two bituminous coals and two pre-dried lignites). Two units were used in the investigation: a 20 kW once-through furnace and a 500 kW furnace with flue gas recycle. The 20 kW unit was used in the majority of parameter studies. This unit has a jet burner capable of being operated in a swirling mode. It is electrically heated, enabling a controlled and constant temperature profile in the reaction zone. Axial gas sampling was performed by a movable probe inserted in the opposite direction of the gas flow. Bottled NO was used to simulate recycled NO_x . The 500 kW unit was constructed for technical-scale testing, and is capable of being operated with different coals and staged combustion. The formation of NO_x has not yet been in focus of the 500 kW unit experiments and the results from this unit are not further discussed.

The IFK investigation draws the following conclusions:

- The conversion of fuel-N to NO is lower in oxy-fuel combustion than in air-firing.
- Oxidant staging is equally effective in oxy-fuel and air combustion in terms of NO_x reduction potential.
- The reduction of recycled NO is highly dependent (reduction ranging from 50-100%) on combustion conditions (e.g. residence time and stoichiometric ratio).
- When oxygen is in excess (unstaged combustion), the reduction of recycled NO is dominated by heterogeneous reactions (indicated by measurements with char of brown coal in a natural gas flame). However, when fuel is in excess (staged combustion), homogeneous reactions dominate the reduction.
- The reduction of recycled NO by homogeneous reactions (in fuel-rich regions) is similar in air and oxy-fuel environments; however, the reduction by heterogeneous reactions (in oxygen rich regions) is higher in oxy-fuel environments. This is explained by the higher concentration of CO, which is known to enhance reduction of NO in heterogeneous reactions.

4.2.3 Technical University of Denmark

The work of DTU primarily focuses on identifying critical issues having to do with gas-phase nitrogen chemistry in oxy-fuel combustion. The chemical effects on combustion and nitrogen chemistry of the increased CO₂ concentration compared to air-firing are central to the investigation, which includes an experimental and a modelling study. The experimental arrangement offers a well controlled environment with a laminar flow and an isothermal reaction zone. The gas composition of the product gas is measured. The reactants (CH₄, NH₃, HCN, NO and O₂) are supplied to the reactor with a bulk gas, dominated by CO₂ or N₂ depending on the application (CO₂ + N₂ > 95%vol). The theoretical work is focused on updating a detailed reaction mechanism for the gas-phase combustion chemistry (as described in Chapter 2) to describe combustion environments with an elevated CO₂ concentration. The experiments are used to validate the updated mechanism.

The DTU investigation draws the following conclusions:

- The oxidation of gaseous compounds in an O₂/CO₂ environment yields significantly increased concentrations of CO above 1400K. This is attributable to the reaction between CO₂ and H radicals, which is known to occur in high CO₂ concentrations.

- Furthermore, CO_2 will compete with O_2 for H-radicals to alter the composition of the radical pool. The effects on the radical pool are the most important homogeneous effects of oxy-fuel combustion on nitrogen chemistry.
- The formation of NO is enhanced under reducing conditions but suppressed under oxidising conditions compared to O_2/N_2 environment.

4.2.4 Summary

The experimental arrangements employed by the three research groups presented above (involving laminar flow and no real recycle of flue gases) do not describe the industrial applications. Instead, these arrangements have the advantage of providing controlled environments to investigate the nitrogen chemistry of relevance for the industrial flame without the complexity associated with turbulence. The DTU arrangement is a small scale laboratory reactor and the most removed from industrial conditions of the three arrangements, while the IFK arrangement approaches technical-scale conditions. The reactants (i.e. recycled NO_x , fuel-N or reactive surfaces) included by the three groups may be controlled, which enables the possibility of focusing on isolated mechanisms of importance to the emission of NO_x .

All studies emphasize that CO is especially critical for NO reduction under oxy-fuel combustion. At BYU thermal dissociation of CO_2 is associated with high CO concentrations due to the high temperature dependence of the increase in CO concentration. Furthermore, based on their modelling, the gasification of char is excluded as an important source of CO under oxy-fuel conditions. In the IFK study, the gasification of char and the water-gas-shift reaction were identified as possible reasons for the increased concentration of CO, but no further investigation was performed. The DTU study is entirely focused on gas-phase chemistry and concludes that the high CO concentration is generated from CO_2 by a radical reaction (similar to the water-gas-shift reaction). In the present work the DTU approach with respect to CO gas-phase chemistry is followed. However, the influence of CO_2 gasification reactions is left out of the study.

The DTU investigation does not observe any direct effects on NO_x formation by the increased CO concentration, although its formation has indirect effects by influencing the pool of chain-carrying radicals. Both BYU and IFK, which include coal in their investigations, emphasize the importance of CO in combination with char for NO reduction. The IFK study supports this finding by showing that oxy-fuel combustion under oxygen-rich operation, offers an increased reduction of NO compared to air firing, when the relative importance of heterogeneous reactions to total reduction is higher. The influence of CO concentration on nitrogen chemistry is further discussed in Chapter 5.

All three groups agree on the importance of reburning of recycled NO for the emission of NO in oxy-fuel combustion. Furthermore, there is a consensus that NO_x reduction in oxy-fuel combustion is less dependent on fuel-rich zones than air-fired systems. IFK attributes this phenomenon to the higher CO concentration and to an increased reduction of NO_x by char in fuel rich regions, while DTU shows lower NO emissions due to suppression of the O/H radical pool in these regions. BYU claims a decrease of thermal NO formation due to a near absence of N₂ in oxy-fuel combustion, which is discussed to be more important in oxygen-rich regions. Furthermore, the practical implication of a higher reduction due to the increase in the recycle ratio with combustion stoichiometry is stressed. Paper I compares the emission of NO_x under air and oxy-fuel conditions and discusses the reasons for the lower emission from oxy-fuel combustion. The performance of the reburning mechanism and the Zeldovich mechanism is evaluated in Paper II, III and IV.

5 - Nitrogen Chemistry in Combustion

In combustion, nitrogen chemistry consists of numerous reactions and pathways for the formation and reduction of NO_x . Figure 5.1 summarizes the main reaction paths. There are two sources of nitrogen during combustion, molecular nitrogen present in the air and nitrogen chemically bound in the fuel (Fuel-N). Typically, in pulverized coal combustion, more than 80% of the NO formed originates from Fuel-N (Pershing and Wendt 1979). Most of the fuel-bound nitrogen is released as volatile compounds and the homogeneous reactions are generally considered to be most important for controlling emission of NO_x (Pershing and Wendt 1979; Bose et al. 1988). The combustion process can be divided into four stages, as shown in Figure 5.2, in which different mechanisms are dominant. The following defines the end of each stage:

- I. Complete oxidation of hydrocarbon volatiles
- II. Introduction of secondary oxygen; switching from reducing to oxidizing conditions
- III. Complete oxidation of CO
- IV. Frozen concentrations

In Figure 5.2 the four stages are shown in sequence or how they would appear under plug-flow conditions. The initial part of the turbulent flame, Stages I and II, is where devolatilization and oxidation of the evolved species take place. During combustion of hydrocarbons, there is an accumulation of CO, which starts

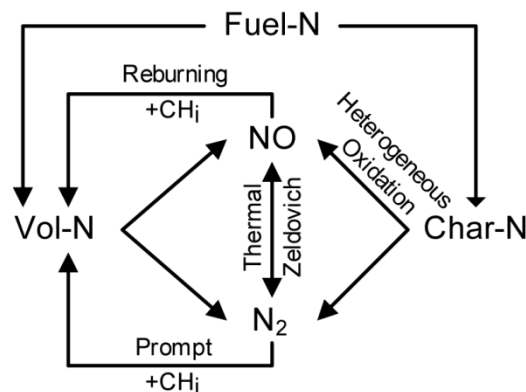

Figure 5.1. Overall mechanisms of NO formation and reduction in combustion. Vol-N denotes volatile nitrogen containing compounds, typically HCN or NH_3 .

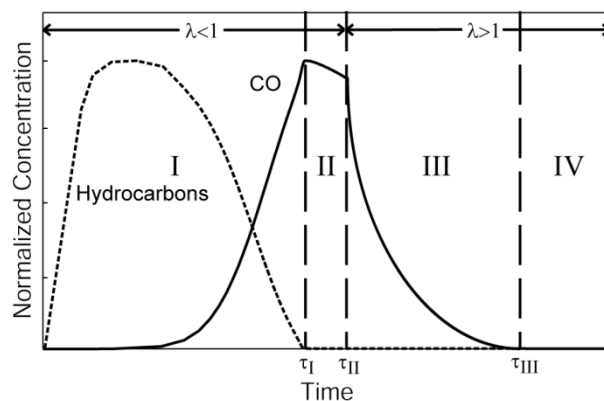

Figure 5.2. Definition of the four stages of the combustion process. Dashed vertical lines indicate the shift between stages and double arrows define zones with different stoichiometric ratios (λ).

to oxidize after the completion of hydrocarbon oxidation. Stage III is at the boundary of Stages I and II where the secondary oxygen mixes with the primary stream and creates an oxidizing environment. Stage IV is the latter part of the flame where the peak temperature has been reached and the activity starts to decline. It consists of char burnout and cooling of the flame until the concentrations are frozen.

In Stage I, nitrogen chemistry is dominated by the evolution of volatile nitrogen compounds from the fuel. The reburning and prompt routes which involve reactions with hydrocarbon radicals are also active during this stage. In the second stage, the hydrocarbons are oxidized and the reburning and prompt routes are no longer active. Instead, the volatile nitrogen compounds formed in the first stage start to oxidize to NO or N₂. In Stage II, the environment is oxygen lean and N₂ is typically the favoured product. In Stage III, the oxidation of intermediate nitrogen species are completed, but here NO is the favoured product. In Stage IV, the activity is low. However, if the temperature is sufficient, the Zeldovich mechanism could be of importance to the emission. This mechanism may also be active in previous stages, but it is slow compared to other mechanisms. The heterogeneous oxidation is slow compared to the gas-phase reactions and the evolution of NO and N₂ from char and the reduction by char may be active also during this final stage.

In this chapter, the main reaction routes of nitrogen chemistry (Figure 5.1) are presented. Findings of the present work on the importance for NO_x formation, and general implications of oxy-fuel combustion are discussed.

5.1 Fuel-N Release

Coal contains around 0.5 to 2.5 wt% of nitrogen. This nitrogen is the most important source of the NO_x formed in combustion (air and oxy-fuel). In combustion, the fuel is decomposed, or pyrolyzed. Volatile compounds are

released during the devolatilization and are oxidized in the gas phase. Different products of the devolatilization dominate at different temperatures: adsorbed water <150°C, formed water 300-400°C, tar and hydrogen 400-900°C, and carbon monoxide and hydrogen >900°C. The combustion of the solid residue is referred to as char burnout or char oxidation. A substantial devolatilization occurs during some tens of milliseconds, while the total burnout of char requires a few seconds for completion.

During devolatilization, fuel-bound nitrogen is split into volatile nitrogen and char-bound nitrogen. The amount of nitrogen released as volatiles is highly dependent on coal type but also on temperature and can be up to 100% of the fuel-bound nitrogen. Table 5.1 presents typical values for three major coal types. Coals of a lower rank have a higher amount of volatiles than higher rank coals, and the amount of volatiles released increases with temperature. The type and relative amount of nitrogen volatiles–release is a matter of discussion (Van Der Lans et al. 1997; Glarborg et al. 2003), but HCN together with NH₃ are the most important species. The general opinion is that HCN dominates for high rank coals, while a greater amount of NH₃ is formed from coals of lower rank. For high-rank coals, tarry compounds, which are made up of numerous different species, are the primary release. These compounds are decomposed to form HCN or nitrogen containing soot particles. For low-rank coals, a larger share of the volatile nitrogen is released directly. The light nitrogen species are oxidized to form NO or N₂, which is further discussed below.

The heterogeneous reactions involved in oxidation of nitrogen bound in the char are complicated and not fully understood, as discussed in the review of Molina et al. (2000). The nitrogen could be released as light nitrogen species at higher temperatures or it could react through a set of heterogeneous reactions along with the oxidation of the char to form either NO_x or N₂. As the oxidation of char is too slow to respond to the conventional combustion modifications, for reduction of NO_x formed from volatiles, most char is oxidized in an oxygen-rich environment and the possibility to influence the NO/N₂ ratio is low. Therefore, char bound nitrogen is an increasingly important contributor to the formation of NO_x as the formation from volatile nitrogen is decreased. Whether a high volatile release is favourable to NO_x emission or not depends, thus, on the performance of the particular system in controlling the oxidation of the volatile species. Generally, for staged combustion, high volatile release is favourable.

Table 5.1. Typical values for various coal types.

Coals	Rank	[MJ/kg]	Proximate [wt%]		[%d.a.f, 900°C]	Ultimate [wt%, d.a.f.]		
		Heat Content	Moister	Ash	Volatiles	C	H	O+N+S
Lignite	Low	<28.5	~40	~5	>45	60-70	~5	20-35
Bituminous	High	<35.3	5-15	5-10	20-45	75-90	~5	5-20
Anthracite	High	<35.3	5-15	10-20	5-10	90-95	<5	<4

In the present work, the conversion of fuel-bound nitrogen to NO is only included on an aggregated level (Paper I), in which the volatile release and conversion of char-bound nitrogen is included. The investigation concludes that the overall conversion of fuel-bound nitrogen to NO is similar or slightly higher in an oxy-fuel environment compared to air-firing. Obviously, oxygen concentration through its influence on combustion temperature is important to the release of fuel-bound nitrogen as volatiles, and thereby also for NO_x emission. No important effect of oxy-fuel combustion on the oxidation of char-bound nitrogen has been reported. In general, there is not a great deal of research on the heterogeneous and fuel-related chemistry in oxy-fuel combustion.

5.2 Heterogeneous Reduction

Heterogeneous reactions between solids (char and soot) and nitrogen species in combustion could be important for the reduction of NO_x. Although numerous studies are performed (see review by Molina et al. (2000)), the interaction between NO_x and particles is not yet fully understood. The general idea is that NO is initially adsorbed on a char surface. The adsorbed NO can then reduce NO to N₂ according to,

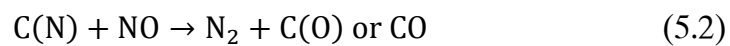
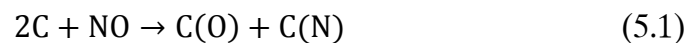

where () denotes an adsorbed atom. Furthermore, the reduction by char seems to be highly dependent on the concentration of CO. The importance of CO is of special interest in oxy-fuel combustion, where the CO concentration is locally increased, owing to the high CO₂ concentration. The importance of CO may be attributable to regeneration of active sites,



or to direct reduction, catalyzed by a surface,

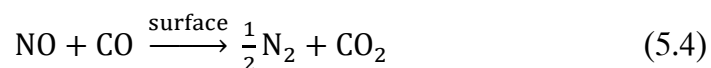

The importance of reduction by char is not explicitly investigated in the present work. However, it could be discussed by looking at differences in result between Paper I, where heterogeneous reactions are included, and Paper III, where they are not included (the same experimental arrangement is used for both investigations). Figure 5.3 presents an estimate of the reduction of recycled NO for three inlet oxygen concentrations from Paper I ($\lambda=1.18$, Lignite) and III ($\lambda=1.15$, Propane). The homogeneous reduction ($\eta_{Homogen}$) is calculated from the propane experiments, which includes no fuel-bound nitrogen, as the ratio of emitted and added NO in mg/MJ of fuel supplied,

$$\eta_{Homogen} = 1 - \frac{NO_{emit}}{NO_{add}} \quad (5.5)$$

The total reduction of homogeneous and heterogeneous reactions ($\eta_{Homogen+Heterogen}$) is estimated based on the lignite experiments. The reduction is calculated as the ratio of emitted NO (mg/MJ fuel supplied) in air and oxy-fuel combustion,

$$\eta_{Homogen+Heterogen} = 1 - \frac{NO_{emit OXY}}{NO_{emit AIR}} \quad (5.6)$$

Equation (5.6) is based on the assumption that the difference between the emission of NO in air and oxy-fuel combustion is completely due to the reduction of recycled NO. As seen in Figure 5.3, the reduction during propane firing is lower than the reduction during lignite firing. The reduction by heterogeneous interactions is one possible explanation for the difference. However, there are other possible explanations as well: the conditions of oxy-fuel combustion (e.g. increased CO₂ and NO concentrations) could influence the conversion of fuel-bound nitrogen to NO. Yet another possible explanation is that there are other systematic differences, e.g. lower temperature and increased sub-stoichiometric zones, which may increase the homogeneous reduction of NO in lignite firing. As indicated by the results in Papers II and III, the temperature difference between the gas and coal fired investigation (around 300°C), may well explain the deviation in reduction capacity in Figure 5.3. The importance of heterogeneous reduction for NO_x emission is an interesting and complicated question, which deserves further investigation but is not treated in greater detail in the present work.

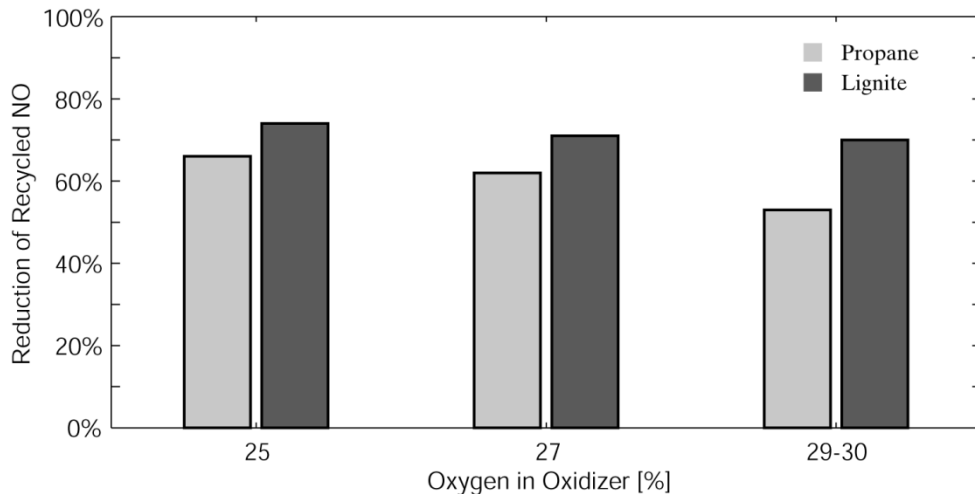
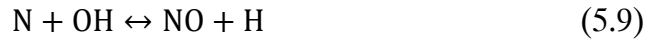

Figure 5.3. Comparison between the reduction of recycled NO during propane (Paper III) and lignite (Paper I) firing in the same experimental unit.

5.3 Thermal NO_x

Thermal NO_x evolves from the recombination of N₂ and O₂, described by the extended Zeldovich mechanism (Zeldovich 1946),



The Reaction (5.7) has high activation energy, which controls the reaction rate of thermal-NO_x formation. Temperatures above 1500°C are required to initiate the reaction, and even higher temperatures are needed for a significant contribution. The Zeldovich mechanism is reversible and reduces NO when the equilibrium concentration of NO is low enough, given that the temperature is sufficiently high for the Zeldovich mechanism to be active.

In oxy-fuel combustion, the elimination of N₂ is obviously important to thermal NO_x. Figure 5.4 presents the influence of N₂ on the equilibrium concentration of NO and on the reduction of 1000 ppm NO during a residence time of 5 seconds at two stoichiometric ratios (λ). At low temperatures, the equilibrium of NO is low, insignificantly dependent on N₂ concentration, and no formation of NO occurs. At higher temperatures, both the equilibrium concentration and the reaction rate of the Zeldovich mechanism increase. When the concentration of N₂ and the oxygen/fuel ratio are high, as during air-firing, NO is formed, but when the concentration of N₂ and λ are low, NO is reduced. The optimal temperature with respect to the NO_x reduction depends on the combustion conditions, but it is higher for oxy-firing than for air-firing. At temperatures above 1600°C, the reduction of NO is strongly dependent on the nitrogen concentration (oxygen purity and air ingress). This dependence is, however, lower at sub-stoichiometric conditions, as seen in Figure 5.4a.

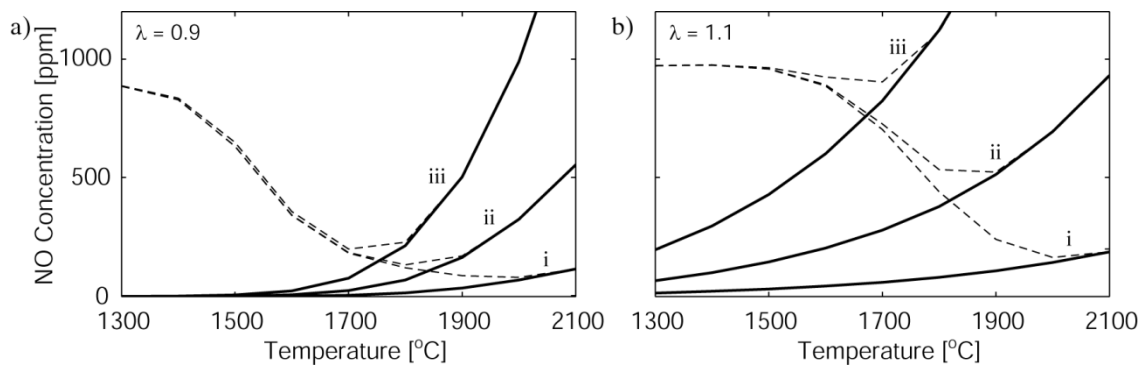

Figure 5.4. Influence of N₂ concentration on the NO_x reduction potential as obtained by modelling of gas-phase chemistry during a) oxygen lean and b) oxygen rich combustion. i - 0% N₂, ii - 1% N₂, iii - 10% N₂. Full lines = equilibrium concentration, dashed lines = 5 seconds residence time. λ = stoichiometric ratio. Initial concentration of NO: 1000 ppm. Ref: Paper V.

5.4 Prompt NO_x

Prompt NO_x is formed in reactions between free nitrogen and hydrocarbon radicals, as described by the Fenimore mechanism (Fenimore 1971). There are many elementary reactions involved, but in general, the mechanism may be described as,



Prompt NO_x formation involves hydrocarbon radicals and this route mostly occurs under fuel-rich conditions. Therefore, staged combustion promotes the prompt formation of NO_x. However, the overall contribution to NO_x formation from this mechanism is already insignificant in air-fired coal combustion, and it has not gained any attention under oxy-fuel combustion where the low concentration of N₂ can be anticipated to further decrease its importance.

5.5 Reburning

Reburning is a common method for in-furnace NO_x reduction (fuel staging) as proposed by Wendt et al. (1973). The reburning mechanism is a route for reduction of NO_x by hydrocarbon radicals, whose global reaction occurs according to,



Similarly to the prompt formation route, reburning depends on the presence of hydrocarbon radicals and, therefore, mainly occurs under fuel-rich conditions. Reburning as a reduction method is widely discussed in connection with oxy-fuel combustion and NO_x emission. It is believed to be the main source of the emission reduction achieved when a large amount of flue gas (and NO_x) is recycled through the burner.

As an illustration of the performance of the reburning process, Figure 5.5 shows a comparison between concentrations of NO, HCN, CH₃ and the sum of CH₂ and CH in air and oxy-fuel combustion, taken from Paper II. The reduction rate is lower during oxy-fuel combustion, which is evidenced by the slower increase of HCN due to the lower concentration of hydrocarbon radicals (CH₁₋₃). This is, however, compensated for by a longer residence time in the reducing zone (Stage I), due to the slower oxidation of the fuel, enabling alternative reaction routes. There is also a change in the composition of hydrocarbon radicals in oxy-fuel combustion: a lower concentration of CH_{1,2} (the peak is almost 500 times lower in oxy-fuel combustion) and a higher CH₃ concentration (similar peak concentration but longer residence time in oxy-fuel combustion). This is important when controlling the combustion process, because the reduction of NO_x becomes more sensitive to temperatures but less sensitive to the stoichiometric ratio, mainly due to this change.

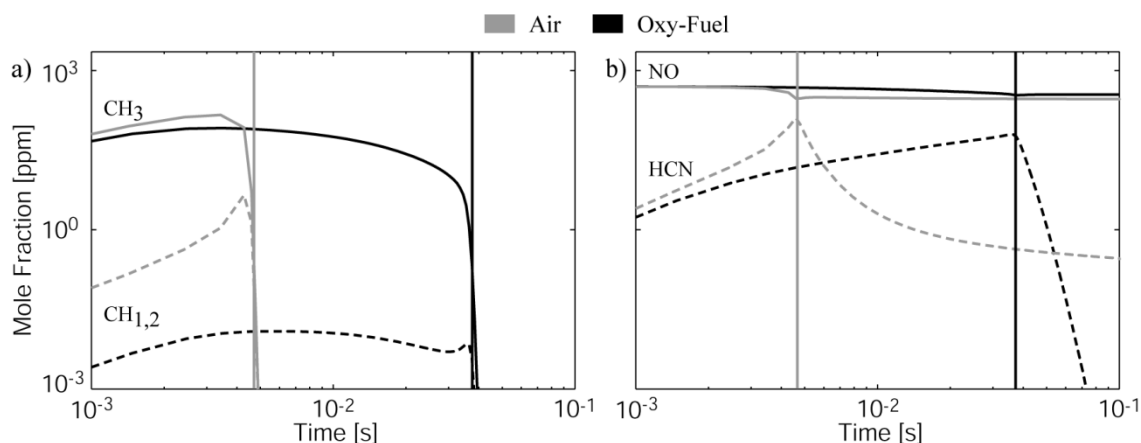

Figure 5.5. Concentration profile of a) CH₃ and CH_{1,2} and b) NO and HCN in air and oxy-fuel combustion with the same oxygen concentration. The temperature is 1400°C and the stoichiometric ratio is 0.7. Vertical lines denote the end of Stage I. Ref: Paper II.

5.6 HCN and NH₃ oxidation

HCN and NH₃ are the main nitrogen species of fuel devolatilization, prompt formation, and reburning reduction. The oxidation of HCN and NH₃ is, thus, central to NO_x formation as it governs the split between NO and N₂ formation and has been the subject of several investigations (e.g. Dagaut et al. (2008), Mendiara and Glarborg (2009a), and Giménez-López et al. (2010)). Figure 5.6 presents the major routes of HCN and NH₃ oxidation. Ultimately, nitrogen is fed into the amine-pool from which NO is formed in reaction with OH, O or O₂ and N₂ in reaction with NO.

Accordingly, the fate of nitrogen in combustion is highly dependent on O, H and OH radicals. As discussed in Chapter 3, the elevated concentration of CO₂ in oxy-fuel combustion could favour the formation OH radicals at the cost of H radicals. As discussed in Paper II, in oxy-combustion, when the concentration of H radicals is low, NCO could react through an alternative path to the amine-pool and form N₂O, NO and N₂ directly. The split between NO and N₂ does, however, depend on similar reactants in both cases. If the oxygen concentration increases, the concentration of chain-carrying radicals also increases and a larger share of the nitrogen is fed to the amine-pool also during oxy-fuel combustion. The change in the radical pool with a switch from H-radicals to OH-radicals in oxy-combustion directly enhances oxidation of the nitrogen fed into the amine-pool and when the oxygen concentration increases, additional NO is formed because the relative order between the radicals assumes greater importance.

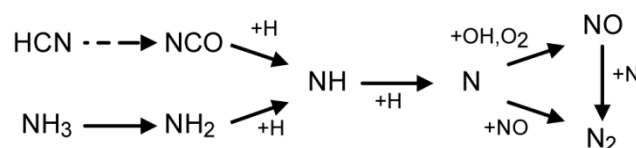

Figure 5.6. Key oxidation routes for HCN and NH₃. Dashed lines indicate multiple reaction steps.

6 - Primary Measures for Oxy-Fuel Combustion

In this chapter, two combustion strategies related to NO_x control under oxy-fuel conditions proposed in the present work are discussed. One approach optimizes the reduction of NO_x by the Zeldovich mechanism, while the other focuses on reduction by the reburning mechanism. The strategy based on reduction by reburning is the more conventional approach, while the strategy based high-temperature reduction has a higher reduction potential and benefits from improved combustion efficiency.

6.1 Reburning NO_x Reduction

In the air-fired application of reburning, the primary combustion zone is the source of NO_x and a secondary fuel-stream is supplied to create the reburning zone. In the oxy-fuel application, NO_x is supplied by the recycled gas, and the primary combustion zone forms the reburning zone. The experiments in Paper I show that recirculation of NO_x into the flame in oxy-fuel combustion lowers the emission with around 70% per unit of fuel supplied compared to air-firing under otherwise similar conditions. A similar reduction in NO_x emission is seen also in other investigations (Allen 1995; Kimura et al. 1995; Woycenko et al. 1995; Châtel-Pélage et al. 2004; Maier et al. 2006; Tan et al. 2006).

The reduction of recycled NO_x by reburning reactions corresponds to conventional combustion measures for NO_x control, why such a large reduction is achieved in the experiments performed with burners designed for air-firing. Temperature and stoichiometric ratio are crucial parameters for an efficient reduction by reburning (both should be kept low). Controlled mixing is important, while the direct effect of inlet oxygen concentration is negligible. Furthermore, the importance of NO_x recycling through the reducing zone is stressed in several studies. Considering these features, reburning reduction in oxy-fuel combustion is favoured by controlled mixing between fuel and oxidizer (i.e. conventional low- NO_x burners), but also by controlling the composition of the oxidizer in different parts of the flame, which is a technique that remains to be fully investigated.

In the early parts of the flame, the oxidizer should contain a low concentration of oxygen. This decreases the mixing rate of fuel and oxidizer, lowers the

temperature in the reducing zone, and ensures that much of the recycled NO_x passes through the reducing zone. Downstream the reducing zone, NO_x is not reduced by reburning reactions. At this location, the concentration of oxygen should be high to support flame stability during the early stages of the flame, and to limit the recycle without significant effects on NO_x reduction. Figure 6.1 illustrates the effects of a differentiated composition of the oxidizer on NO reduction. Three cases with an overall oxygen concentration of 30% in the oxidizer are compared: a reference case (30/30% of oxygen) with a uniform composition and two differentiated cases (10/50% and 20/40% of oxygen), in which the half of the oxidizer with a higher oxygen concentration is injected into a later stage of the flame. The fuel is methane (no fuel-bound nitrogen) and the oxidizer, which globally contains 500 ppm NO , is gradually mixed with the fuel during the first 0.5 meters. The temperature profile is not changed between the different oxidants (more details on the simulations are to be found in Paper III).

When the oxygen concentration is decreased, the molar flow of NO in the oxidizer increases and vice versa. Therefore, additional NO is introduced in the initial stage of the flame with the differentiated oxidizers, but the reduction is larger and all cases reach approximately the same minimum of NO concentration. In the differentiated cases, less NO is introduced downstream of the reduction zone and the outlet concentration is considerably lower. The effect on temperature is not included in this investigation, but as discussed above, the influence on temperature of a differentiated oxidizer is expected to further improve the reduction. Differentiation of the oxidizer is a simple way to utilize the possibilities of oxy-fuel combustion to improve the reburning process and conventional technology in reducing NO_x emission.

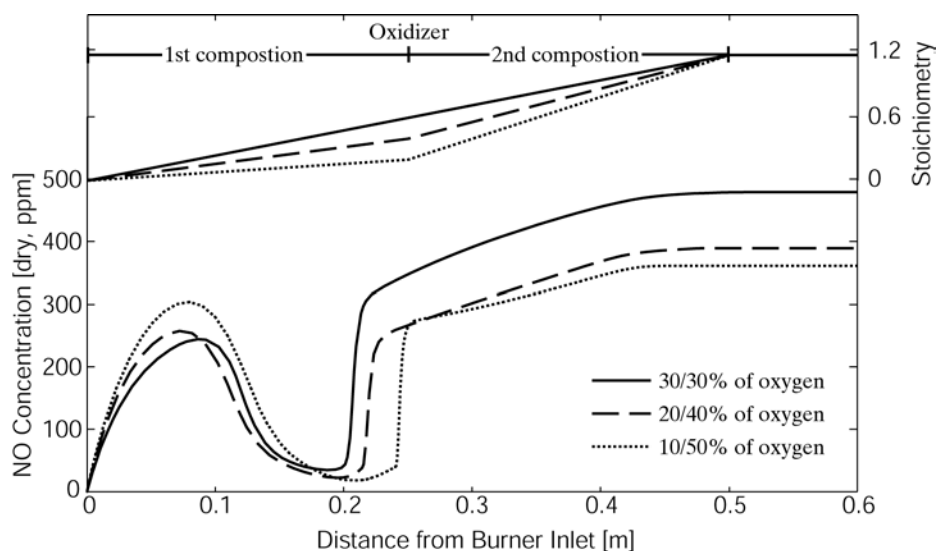

Figure 6.1. Comparison of in-flame NO concentrations and combustion stoichiometry between oxidizers with an overall oxygen concentration of 30% with differentiated composition. The upper part of the figure denotes the local stoichiometry. No fuel-bound nitrogen is included, 500 ppm NO is injected together with the oxidizer, $\lambda=1.15$. Ref: Paper III.

6.2 High-Temperature NO_x Reduction

This section presents a combustion process that uses high combustion temperatures to reduce nitrogen oxides in oxy-fuel combustion by utilizing the reversed Zeldovich mechanism. In order for the high-temperature reduction to be of importance, an oxy-fuel furnace should be designed for an oxidizer with a high concentration of oxygen (low flue-gas recirculation) and with burners promoting rapid mixing to achieve a high combustion temperature; 1800 to 2000°C. Such a design aims at an intense combustion process and lower volume flows through the furnace to increase combustion efficiency and achieve a more compact boiler. In the proposed process, the concentration of nitrogen should be kept low in the combustion environment (~1%) through high purity oxygen and low levels of air ingress to decrease the equilibrium concentration of NO (cf. Figure 5.4). The major feature of such high temperature conditions is melting of the ashes, which has to be handled by the furnace design. Boilers (air fired) with “wet” ash drainage exist and a similar design should be applicable. In principle, this work has proven the high-temperature NO_x reduction by modelling, employing detailed reaction mechanisms with NO_x reduction efficiencies of up to 95%; however, experimental validation of this reduction method remains to be done.

Figure 6.2 compares NO_x emissions in high-temperature combustion against conventional combustion (the reference case, 1500°C) calculated by using the detailed kinetic mechanism by Skreiberg et al. (2004). The inlet concentration of NO (denoted by a circle in Figure 6.2) is the outlet concentration of the furnace adjusted for the addition of oxygen to the recycled flue gas. The difference between inlet and maximum concentrations of NO arises from the conversion of volatile-N to NO, which is occurring rapidly at the time scale of the diagram. The diagram shows that the reduction during high-temperature combustion is improved compared to the reduction typical for air-fired units at lower temperatures. Staging of the oxidizer reduces the emission further. A rate-of-production analysis, integrated from 0.1 milliseconds to 2.5 seconds, shows that the reaction route of the reverse Zeldovich mechanism (Reactions (5.7) to (5.9)) dominates the reduction of NO. The initial 0.1 milliseconds are left out as they are dominated by the oxidation of fuel-bound nitrogen. A high-temperature combustion strategy depends on the conditions of the oxy-fuel combustion, as it would form NO_x from air-borne nitrogen under air-fired conditions.

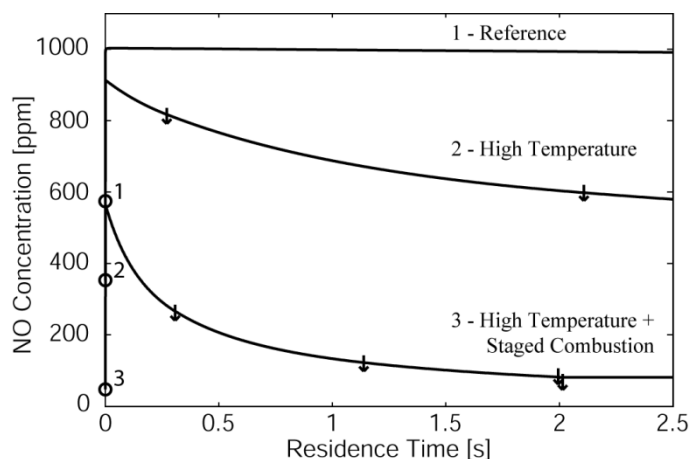

Figure 6.2. Performance of high-temperature NO_x reduction. Calculation of oxy-methane combustion in a plug flow reactor with recycle of flue gases and a mixture of HCN (60%) and NH₃ to represent fuel-bound nitrogen (0.6 wt% d.a.f.). The circles indicate the inlet concentration of NO and the arrows indicate a temperature drop of 100°C. Maximum temperature is 1500°C and 2000°C in the Reference and High-Temperature cases, respectively. The stoichiometric ratio is 1.1, except during the first 2 seconds of the Staged Combustion case when it amounts to 0.8. Ref: Paper IV.

6.3 Combined Reduction

A high-temperature reduction strategy will always include some reburning reduction and vice versa. A combined reduction refers to a strategy which utilizes both reduction routes. The strategy for reburning reduction and for high-temperature reduction are opposites of each other in the way that one includes high temperature and rapid mixing, while the other suggests controlled mixing and moderate temperatures. However, the two reduction mechanisms also complement each other; as they are active in different stages of the combustion process and they do not directly interfere with each other. Reburning can only occur in the relatively limited zones where hydrocarbon radicals are present. Thermal reduction, on the other hand, does not require any reducing agents but are instead relatively slow and, as mentioned, dependent on a sufficiently high temperature.

The challenge of achieving an efficient combined reduction is to, as rapidly as possible, increase the temperature of the combustion after leaving Stage I (Figure 5.2), where both temperature and mixing are controlled. The negative aspect of a combined strategy is the increased complexity of the system. Compared to the high-temperature reduction without reburning, the advantage is the high initial reduction rate, which reduces the required residence time under high-temperature conditions. Compared to the reburning strategy, the advantage is the opportunity to push the reduction further by secondary reduction.

7 - Secondary Measures for NO_x Control

This chapter presents options for secondary NO_x control in oxy-fuel power plants (reviewed in Paper V) for comparison with the proposed options for primary control. Secondary measures aim at converting or capturing NO_x in the flue gas downstream of the combustion process. Generally, secondary measures have the disadvantage of requiring additional equipment and additives to control the emission. On the other hand, they do not interfere with the combustion process and usually perform better in terms of NO_x reduction than primary measures. The focus is on the new possibilities presented due to the changed conditions of the oxy-fuel flue gas train; however, the two most common secondary measures, selective catalytic reduction (SCR) and selective non-catalytic reduction (SNCR), are also included. Figure 7.1 illustrates the SCR/SNCR and the three options to capture NO₂ presented: absorption in water, co-storage with CO₂, and distillation. The SCR/SNCR can be performed at various locations depending on process conditions, while the NO₂ removal processes must be located in the high-pressure part of the flue-gas train (Streams 4 to 6 in Figure 3.1).

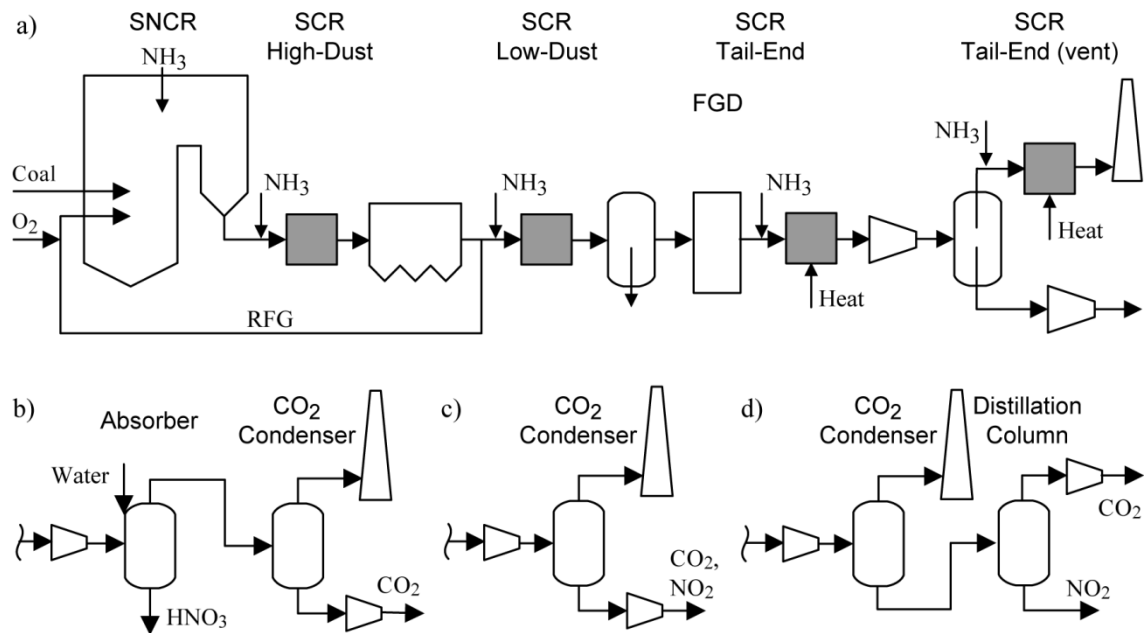
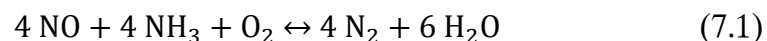

Figure 7.1. Options for secondary NO_x control in the oxy-fuel flue gas train: a) selective reduction, b) absorption, c) co-storage with CO₂, d) distillation.

The effort put into research on secondary NO_x control in oxy-fuel combustion is far removed from the many and detailed studies on primary NO_x control. The company Air Products, in recent years in cooperation with Imperial College in London, have, however, a series of investigations on the oxy-fuel flue gas system and concepts based on the increased oxidation rate of NO into NO₂ at increased pressures. They applied early for a patent on distillation concepts in 1992 (Prentice and Allam 1992), but has mostly been focussing on the process often referred to as the Lead-chamber concept, named after an old process for sulphuric acid production (Müller 2002). The lead-chamber concept for NO_x and SO_x control in oxy-fuel combustion was patented by Air Products in 2007 (Allam et al. 2007), and has been presented at several conferences and meetings. The latest and most extensive publication is by White et al. (2010). Furthermore, the distillation and the lead chamber concepts have been theoretically evaluated by Kühnemuth et al (2008). The knowledge about the design and performance of both these processes is sparse, but the Lead-chamber concept has gained common acceptance over the last few years. The work taking place at Hamburg-Harburg University on phase separation during the CO₂ condensation process, summarized by Kather and Scheffknecht (2009) also deserves mentioning, even though, neither NO nor NO₂ have been included in their studies (besides equilibrium calculations). Their results indicate a required operation range for the condenser of between 15 and 30 bars, and between -55°C and -25°C to achieve CO₂ purity of 95-98% and a capture rate of above 90%.

7.1 Selective Reduction

Selective reduction is based on the reaction between NO and ammonia (or urea) to form nitrogen and water,



In the non-catalytic process (SNCR), the reduction takes place at a temperature of between 800 and 1100°C, and employing a catalyst (SCR) usually at 300-400°C. The ammonia is injected into the flue gas upstream of the catalyst or in the appropriate temperature window, depending on the process. Appropriate mixing conditions for NH₃ and fast reactions are important to avoid ammonia slip (unreacted ammonia in the flue-gas after the NO_x reduction unit) with possible downstream consequences, such as the build-up of ammonium salts on heat transfer surfaces, the emission of ammonium chloride and gaseous ammonia, and the contamination of the CO₂.

The influence of oxy-fuel combustion on selective reduction or catalyst activity remains to be investigated. However, the flue-gas train of an oxy-fuel power plant offers new potential locations of the SCR unit. The cost of an SCR unit depends on the flue gas volume, and a location in the latter stages of the oxy-fuel flue-gas

train is, therefore, beneficial: the treated volume decreases throughout the flue gas train and is smaller than in an air-fired power plant (see Figure 3.3a). The reduction of NO by Reaction (7.1) is not thermodynamically favoured by increased pressure and the SCR unit should not be placed in the pressurized part of the flue-gas train. Figure 7.1a shows the four basic locations of the SCR reactor in the flue gas treatment train: high-dust, low-dust, tail-end and tail-end vent. The low-dust option is normally not used in air-fired power plants due to the high cost of installing a high-temperature dust separation. However, in oxy-fuel combustion flue-gas recycle at higher temperatures gives an incentive to install a high-temperature dust separator. The low-dust SCR is placed outside the recycle loop and has lower catalyst degradation compared to a high-dust option. Oxy-fuel flue gas contains high concentrations of SO₂. To prevent SO₃ formation in the SCR, a flue-gas desulphurization unit (FGD) prior to the SCR may be required. This would require a tail-end SCR with a re-heat of flue gases before the SCR unit and with a negative impact on plant efficiency. In the tail-end (vent) option, the SCR unit is placed downstream of the CO₂-condenser and only a fraction of the initial volume is processed. In this case, the NO_x following the CO₂ stream is not reduced.

7.2 Absorption of NO_x

The absorption of NO_x in water has been thoroughly studied due to its importance for the industrial production of nitric acid, see Thiemann et al. (2002) and references therein. NO is oxidized in the gas phase before it is absorbed and finally bound in the liquid as HNO₃. The oxidation of NO into NO₂ is the critical step for the absorption. As discussed in connection with Figure 3.3b, the low temperature and high pressure during the CO₂ condensation step of the oxy-fuel flue gas train promote NO₂ formation. The initial concentration of NO_x in the gas and the concentration of HNO₃ in the absorbing liquid are important design parameters. The absorption in water has been proposed as a means of secondary NO_x control in air-fired power plants. The requirement of a strong oxidizer (e.g. ozone or hydrogen peroxide) or an efficient catalyst to oxidize NO into NO₂ at atmospheric pressure has, however, prevented these processes to reach the stage of commercial breakthrough.

The absorption of NO_x in oxy-fuel power plants around 30 bar and 30°C is proposed as a feasible technique, with reduction efficiencies reading as high as 90%. The absorption is limited by equilibrium. When discussed, absorption of NO_x in oxy-fuel power plants is often combined with a simultaneous removal of SO₂ based on the Lead-chamber process. In this process, the NO₂ formed functions as a catalyst for the rapid oxidation of SO₂ into SO₃, which is highly soluble in water and is converted into sulphuric acid. Initial small-scale experiments have been performed on the SO₂ absorption with promising results

(White et al. 2010). However, the technique cannot be considered mature, as can the absorption of NO₂.

7.3 Phase-Separation

Phase-separation is a common industrial method for separating the components of a mixture. The separation is based on the difference of composition between the liquid and the gaseous phase of the mixture. In the oxy-fuel flue gas train, phase separation is performed in connection with the CO₂ condenser in order to separate gaseous O₂, N₂ and Ar. The boiling point of NO₂ ($T_{b,30\text{bar}} \approx 100^\circ\text{C}$) is higher than the boiling point of CO₂ ($T_{b,30\text{bar}} \approx 0^\circ\text{C}$), and NO₂ is condensed in the CO₂ condenser. In contrast, NO has a lower boiling point than CO₂ ($T_{b,30\text{bar}} \approx -100^\circ\text{C}$) and is emitted together with the vented gases from the CO₂ condenser. An option to control the atmospheric emission of NO_x is, thus, to co-store NO₂ together with the captured CO₂ (Figure 7.1c). To avoid the emission of NO, the residence time of the flue-gas at elevated pressure must be sufficient in order for the oxidation of NO into NO₂ to proceed (see Figure 3.3b). This option for NO_x control may be achieved without additional equipment as the CO₂ condenser is required anyway, but the CO₂ to be stored becomes polluted by NO₂, a result which may not be acceptable.

To prevent pollution of the CO₂ stream, Prentice and Allam (1992) have suggested designing a process with a distillation column operating at a higher temperature downstream of the CO₂ condenser (Figure 7.1d) in order to separate NO₂ from the CO₂ stream. In this column NO₂ remains in the liquid-phase, while CO₂ is separated as a gas. However, CO₂ must be condensed again before transportation. The separation of CO₂ and NO₂ is efficient and a high reduction of the NO_x emission is achieved (up to 97%) (Kühnemuth et al. 2008); however, some additional compression, work besides that needed for the condensation of CO₂, would be required. SO₂ has a boiling point between CO₂ and NO₂ ($T_{b,30\text{bar}} \approx 100^\circ\text{C}$) and may be separated from the NO₂ in the second column at the cost of even further increased compression work.

8 - Conclusion

This work investigates primary measures for NO_x control (Papers I-IV), and compares them to secondary removal options (Paper V). The conclusions on primary NO_x control of this thesis is presented below, which is followed by a discussion of the strategy for NO_x control in oxy-fuel power plants, and an identification of critical areas for the continued development of NO_x control in oxy-fuel combustion.

8.1 Conclusions on Primary NO_x Control

Paper I identifies the important features of oxy-fuel combustion of coal with respect to NO_x emission. It concludes that the amount of emitted NO per unit of fuel supplied is reduced by 70-75% of the emission at air-firing by increased reduction of formed and recycled NO in oxy-fuel combustion. The absence of N₂ is not important for the observed reduction of NO (since the maximum temperature in the experiments was 1300°C), and the conversion of fuel-N to NO is similar or even slightly higher during oxy-firing compared to air conditions. The reburning and reverse Zeldovich mechanisms are identified to be of special interest in oxy-fuel combustion.

The reburning mechanism under oxy-fuel operation is investigated in Papers II and III. Reburning under air-fired conditions is an established method for NO_x reduction, and the investigation is focused on finding differences to that process. Combustion temperature and stoichiometric ratio are key factors to induce efficient NO_x reduction by reburning (both should be kept low) also in oxy-fuel combustion. Compared to air firing, the reduction under oxy-firing is more sensitive to temperature but less sensitive to stoichiometric ratio. This is attributable to the altered oxidation of hydrocarbon radicals under oxy-fuel conditions, resulting in a higher dependence on CH₃ relative to CH_{1,2} as a reducing agent. Furthermore, the amount of flue gas recycled into the flame is important for the reduction of NO_x, since this is where the reburning mechanism is active.

The opportunity of utilizing the reverse Zeldovich mechanism for high-temperature reduction of NO_x under oxy-fuel conditions is investigated in Paper IV. The high-temperature reduction is sensitive to the presence of N₂ and O₂,

both of which must be kept low ($N_2 < 1-5\%$ and $\lambda < 1$) in the reducing zone. As the reduction proceeds, the combustion temperature must be high ($> 1800^\circ\text{C}$), but decreasing throughout the reducing zone. It is concluded that the reduction by the Zeldovich mechanism may be made more efficient than the reduction by the reburning mechanism. However, high-temperature reduction still requires experimental validation.

8.2 Discussion on NO_x Control in Oxy-Fuel Power Plants

Based on the review in Paper V and the investigations on primary measures in Papers III and IV, Table 8.1 summarizes conventional measures (applicable to air-fired plants), as well as innovative measures (only applicable to oxy-fuel plants) for primary and secondary control of NO_x . Overall, the conditions for controlling the emission of NO_x from an oxy-fuel power plant are better and the number of parameters available for process optimization is higher than for an air-fired power plant, both with respect to primary and secondary measures. Primary measures are favoured by:

- the reduction of recycled NO_x ,
- low levels of N_2 and, thus, low equilibrium concentrations of NO , and
- higher flexibility due to the possibility of controlling the inlet oxygen concentration.

Secondary measures are favoured by:

- significantly reduced flue gas volume flows,
- the possibility to control NO_x as NO_2 , and
- the possibility to store NO_x together with the CO_2 .

A first generation of oxy-fuel power plants is likely to use conventional technology to the extent possible. If applied to NO_x control, this means low- NO_x burners with delayed mixing and over-fire air for primary control and/or an SCR unit located outside the recycle loop but before the flue gas condenser for secondary control. This strategy would achieve lower emissions of NO_x (mg/MJ fuel) and at a lower cost than for a corresponding air-fired plant, which would probably be sufficient to meet all the limitations on NO_x . However, the oxy-fuel power plant offers the advantage of being able to be developed into an even more efficient, second generation plant. Such a strategy could include a furnace with rapid-mixing burners, lower recycle flows and higher oxygen concentrations to provide a more compact boiler. In air-firing, such a strategy would have a high generation of NO_x , but under oxy-fuel conditions, this strategy could be even more efficient than the conventional approach of reducing NO_x . Concerning secondary measures, the key issue is to take advantage of the NO_2 formation. The units required for the absorption of NO_2 in water or storage with CO_2 are inherent steps in the flue gas treatment, which makes them interesting options, given that the reactions may be controlled.

Table 8.1. Summary of the performance of NO_x control measures when applied to an oxy-fuel power plant. The achievable reduction refers to the measure concerned; different measures are not to be added. The achievable reduction for High temperature is in combination with staging.

	Advantages	Disadvantages / Tendencies	Achievable Reduction
Primary Measures			
Reburning	Conventional technology	(Natural gas consumption) High-temperature corrosion	60% ^a
Staging	Conventional technology	Reduced combustion efficiency High-temperature corrosion	40% ^a
Low-NO _x burner	Conventional technology	Reduced combustion efficiency High-temperature corrosion	60% ^a
Flue gas recirculation	Inherent in oxy-fuel combustion		80% ^b
High temperature	Improved combustion efficiency Small and compact furnace	Melting of ashes Requires low N ₂ concentration High-temperature corrosion	90% ^b
Secondary Measures			
SCR	Conventional technology	Requires catalysts Ammonia consumption Extra units Ammonia slip	95% ^a
SNCR	Conventional technology	Ammonia consumption Ammonia slip	50% ^a
Absorption	Simultaneous removal of SO _x Placed in high-pressure part	Extra units Waste (weak nitric acid)	90% ^b
Co-storage	Inherent in the CO ₂ treatment	Pollution of the CO ₂	95% ^b
Distillation	Simultaneous removal of SO _x Placed in high-pressure part	Power consumption Extra units Waste (liquid NO _x)	95% ^b

a) Based on practical experience under air-fired conditions (IPPC 2006).

b) Based on modelling of the oxy-fuel flue gas train (Papers III and IV), (Kühnemuth et al. 2008).

In modern power plants, primary measures are the most common NO_x control strategies. When primary measures are not sufficient to meet emission targets, secondary removal may be adopted. For oxy-fuel power plants, this will not necessarily be the case since the limitations on the presence of NO_x will most likely determine whether secondary removal options might be adopted or not. There are three main issues to consider: nitric acid formation in the compressors, NO₂ content in the CO₂ to be stored, and NO emitted together with the vent stream. To arrive at the most suitable measure, three scenarios with different constraints are defined in Table 8.2.

In the first scenario, the restrictions on acid formation in the compressor are high and NO_x has to be controlled early in the process. Extensive reduction in the combustion process should be applied. If primary measures are not sufficient to prevent acid formation from NO_x, an SCR unit is required before the compression. It is also possible to control the amount of water or SO₂ to prevent acid formation. In the second scenario, the limitations in the CPU are lower, but not negligible. NO_x formation should be considered in the combustion design but extensive reduction is not required. Instead, the controlled oxidation of NO and absorption of NO₂ is a favoured strategy to meet NO_x limitations. In the third scenario, there are no important limitations except on the gases emitted into the atmosphere. In this case, the design of the combustion process does not need to consider NO_x formation. The controlled oxidation of NO and the storage of NO₂ with CO₂ are favourable. Some NO₂ will be absorbed in the condensate, but there is no need for installing columns to enhance the absorption.

The scenarios outlined illustrate how limitations in NO_x influence the design of the process. Besides process limitations, there are also other uncertainties in arriving at the optimal organisation of NO_x control: experimental validation is needed for several of the measures discussed in this work, and the cost of the solutions needs to be evaluated.

Table 8.2. Definition of scenarios for required NO_x control in the compressor unit (CPU), storage stream (CO₂), and vent stream (Vent).

	CPU	CO ₂	Vent
Scenario 1	High	<CPU	<CPU
Scenario 2	Normal	High	High
Scenario 3	Low	Low	Normal

High - Not possible to achieve with conventional primary measures alone.
Normal - Possible to achieve with conventional primary measures
Low - No important limitations

8.3 Future Work

Based on the discussion above, three key areas in which more work is required have been identified with respect to NO_x emission and the design of future oxy-fuel power plants.

Limitations on NO_x . NO_x control has historically been driven by emission legislation. However, in oxy-fuel power plants, corrosion issues might place even more stringent requirements on NO_x control. Regulations adapted to CO_2 removal processes, both with respect to emissions into the atmosphere and with respect to the storage gas, as well as the further understanding of formation and consequences of acids in pressurized flue-gas systems are, therefore, required in order to arrive at appropriate design solutions for the oxy-fuel CO_2 capture system.

Oxidation of NO into NO_2 . The differences in behaviour of NO and NO_2 make it essential to further investigate the oxidation of NO under the conditions of the oxy-fuel flue gas train. Absorption of NO_2 , the role of NO_x in the absorption of SO_2 and the performance of the CO_2 condenser in separating NO and NO_2 are crucial issues connected to the oxidation of NO .

The Combustion Process. NO_x control has constrained the design of air-combustion since the beginning of the 1970's. It is shown that both changed combustion conditions and cost effective secondary measures in oxy-fuel combustion could lower the importance of controlled mixing and limited combustion temperatures with respect to NO_x emission. It is, therefore, of importance not to mimic air-combustion in future developments but rather utilize the opportunities given by oxy-fuel combustion to find the optimal performance, both with respect to emissions, combustion efficiency and investment cost. The high-temperature reduction and the reburning of recycled NO_x are interesting candidates for future developmental in the area of oxy-fuel combustion.

9 - References

- Allam, R. J., White, V., and Miller, J. (2007). "Purification of carbon dioxide." *Air Products*.
- Allen, G. (1995). "Coal combustion in advanced burners for minimal emission and carbon dioxide reduction technologies." *Report No. 26428*.
- Alzueta, M. U., Bilbao, R., Millera, A., Glarborg, P., Østberg, M., and Dam-Johansen, K. (1998). "Modeling low-temperature gas reburning. NO_x reduction potential and effects of mixing." *Energy and Fuels*, 12(2), 329-338.
- Baulch, D. L., Bowman, C. T., Cobos, C. J., Cox, R. A., Just, T., Kerr, J. A., Pilling, M. J., Stocker, D., Troe, J., Tsang, W., Walker, R. W., and Warnatz, J. (2005). "Evaluated kinetic data for combustion modeling: Supplement II." *Journal of Physical and Chemical Reference Data*, 34(3), 757-1397.
- Bose, A. C., Dannecker, K. M., and Wendt, J. O. L. (1988). "Coal composition effects on mechanisms governing the destruction of NO and other nitrogenous species during fuel-rich combustion." *Energy and Fuels*, 2(3), 301-308.
- Bowman, C. T. (1997). "Mechanisms and Modeling of gas-phase aftertreatment methods for NO removal from combustion products." *Physical and Chemical Aspects of Combustion*, F. L. Dryer and R. F. Sawyer, eds., Overseas Publishers Association, Amsterdam.
- Cao, H., Sun, S., Liu, Y., and Wall, T. F. (2009). "Computational Fluid Dynamics Modeling of NO_x Reduction Mechanism in Oxy-Fuel Combustion." *Energy and Fuels*, 24(1), 131-135.
- Châtel-Pélage, F., Varagani, R., Pranda, P., Perrin, N., Farzan, H., Vecchi, S. J., Lu, Y., Chen, S., Rostam-Abadi, M., and Bose, A. C. (2004). "NO_x control or CO₂ capturing in coal-fired power plants: why using oxygen?" AFRC-JFRC Joint International Combustion Symposium, Maui.
- Chui, E. H., Douglas, M. A., and Tan, Y. (2003). "Modeling of oxy-fuel combustion for a western Canadian sub-bituminous coal." *Fuel*, 82(10), 1201-1210.
- Chui, E. H., Majeski, A. J., Douglas, M. A., Tan, Y., and Thambimuthu, K. V. (2004). "Numerical investigation of oxy-coal combustion to evaluate burner and combustor design concepts." *Energy*, 29(9-10), 1285-1296.
- Croiset, E., and Thambimuthu, K. V. (2001). "NO_x and SO₂ emissions from O₂/CO₂ recycle coal combustion." *Fuel*, 80(14), 2117-2121.

- Dagaut, P., Glarborg, P., and Alzueta, M. U. (2008). "The oxidation of hydrogen cyanide and related chemistry." *Progress in Energy and Combustion Science*, 34(1), 1-46.
- Dagaut, P., Lecomte, F., Mieritz, J., and Glarborg, P. (2003). "Experimental and Kinetic Modeling Study of the Effect of NO and SO₂ on the Oxidation of CO-H₂ Mixtures." *International Journal of Chemical Kinetics*, 35(11), 564-575.
- Dhungel, B. (2009). "Experimental investigations on combustion and emission behaviour during oxy-coal combustion," Dissertation, Stuttgart University, Stuttgart, Germany.
- EU. (2008). "Directive 2008/1/EC of the European parliament and of the council."
- EU. (2009). "Directive 2009/31/EC of the European parliament and of the council."
- Fenimore, C. P. (1971). "Formation of nitric oxide in premixed hydrocarbon flames." *13th Symposium on Combustion*, 373-379.
- Giménez-López, J., Millera, A., Bilbao, R., and Alzueta, M. U. (2010). "HCN oxidation in an O₂/CO₂ atmosphere: An experimental and kinetic modeling study." *Combustion and Flame*, 157(2), 267-276.
- Gimenez, J., Rasmussen, C. L., Alzueta, M. U., Gao, Y., Marshall, P., and Glarborg, P. (2009). "Experimental and Kinetic Modeling Study of C₂H₄ Oxidation at High Pressure." *Proc. Combust. Inst.*, 32, 367-375.
- Glarborg, P., and Bentzen, L. L. B. (2008). "Chemical effects of a high CO₂ concentration in oxy-fuel combustion of methane." *Energy and Fuels*, 22(1), 291-296.
- Glarborg, P., Jensen, A. D., and Johnsson, J. E. (2003). "Fuel nitrogen conversion in solid fuel fired systems." *Progress in Energy and Combustion Science*, 29(2), 89-113.
- Glarborg, P., Miller, J. A., and Kee, R. J. (1986). "Kinetic modeling and sensitivity analysis of nitrogen oxide formation in well-stirred reactors." *Combustion and Flame*, 65(2), 177-202.
- Hu, Y., Naito, S., Kobayashi, N., and Hasatani, M. (2000). "CO₂, NO_x and SO₂ emissions from the combustion of coal with high oxygen concentration gases." *Fuel*, 79(15), 1925-1932.
- Hu, Y. Q., Kobayashi, N., and Hasatani, M. (2001). "The reduction of recycled-NO_x in coal combustion with O₂/recycled flue gas under low recycling ratio." *Fuel*, 80(13), 1851-1855.
- Hu, Y. Q., Kobayashi, N., and Hasatani, M. (2003). "Effects of coal properties on recycled-NO_x reduction in coal combustion with O₂/recycled flue gas." *Energy Conversion and Management*, 44(14), 2331-2340.
- IEA. (2009). "World Energy Outlook." IEA, Paris.
- IPPC. (2006). *Reference document on best available techniques for large combustion plants*, European IPPC Bureau.

- Kaß, H., Tappe, S., and Krautz, H. J. (2009). "The combustion of dry lignite under oxy-fuel process conditions in a 0.5 MW_{th} test plant." *9th International Conference on Greenhouse Gas Control Technologies*, Washington, 423-430.
- Kather, A., and Scheffknecht, G. (2009). "The oxycoal process with cryogenic oxygen supply." *Naturwissenschaften*, 96(9), 993-1010.
- Kiga, T., Takano, S., Kimura, N., Omata, K., Okawa, M., Mori, T., and Kato, M. (1997). "Characteristics of pulverized-coal combustion in the system of oxygen/recycled flue gas combustion." *Energy Conversion and Management*, 38(1), 129-134.
- Kilpinen, P., Glarborg, P., and Hupa, M. (1992). "Reburning chemistry: A kinetic modeling study." *Industrial & Engineering Chemistry Research*, 31(6), 1477-1490.
- Kim, H. K., Kim, Y., Lee, S. M., and Ahn, K. Y. (2007). "NO reduction in 0.03-0.2 MW oxy-fuel combustor using flue gas recirculation technology." 3377-3384.
- Kimura, N., Omata, K., Kiga, T., Takano, S., and Shikisima, S. (1995). "The characteristics of pulverized coal combustion in O₂/CO₂ mixtures for CO₂ recovery." *Energy Conversion and Management*, 36(6-9), 805-808.
- Kühnemuth, D., Normann, F., Johnsson, F., and Andersson, K. (2008). "Evaluation of concepts for secondary SO₂ and NO_x removal from the oxy-fuel process." 15th International Conference on the Properties of Water and Steam, Berlin.
- Li, Q., Zhao, C., Chen, X., Wu, W., and Li, Y. (2009). "Comparison of pulverized coal combustion in air and in O₂/CO₂ mixtures by thermo-gravimetric analysis." *Journal of Analytical and Applied Pyrolysis*, 85, 521-529.
- Liu, F., Guo, H., Smallwood, G. J., and Gülder, Ö. L. (2001). "The chemical effects of carbon dioxide as an additive in an ethylene diffusion flame: implications for soot and NO_x formation." *Combustion and Flame*, 125(1-2), 778-787.
- Liu, H. (2009). "Combustion of Coal Chars in O₂/CO₂ and O₂/N₂ Mixtures: A Comparative Study with Non-isothermal Thermogravimetric Analyzer (TGA) Tests." *Energy and Fuels*, 23, 4278-4285.
- Liu, H., Zailani, R., and Gibbs, B. M. (2005). "Comparisons of pulverized coal combustion in air and in mixtures of O₂/CO₂." *Fuel*, 84(7-8), 833-840.
- Mackrory, A. J. (2008). "A mechanistic investigation of nitrogen evolution in pulverized coal oxy-fuel combustion," Dissertation, Brigham Young University, Provo, Utah, USA.
- Maier, J., Dhungel, B., Mönckert, P., and Scheffknecht, G. (2006). "Coal combustion and emission behaviour under oxy-fuel combustion." *31st International Technical Conference on Coal Utilization and Fuel Systems*, Clearwater.
- Mendiara, T., and Glarborg, P. (2009a). "Ammonia chemistry in oxy-fuel combustion of methane." *Combustion and Flame*, 156(10), 1937-1949.
- Mendiara, T., and Glarborg, P. (2009b). "Reburn chemistry in oxy-fuel combustion of methane." *Energy and Fuels*, 23(7), 3565-3572.

- Miller, J. A., Branch, M. C., and Kee, R. J. (1981). "A chemical kinetic model for the selective reduction of nitric oxide by ammonia." *Combustion and Flame*, 43(C), 81-98.
- Molina, A., Eddings, E. G., Pershing, D. W., and Sarofim, A. F. (2000). "Char nitrogen conversion: implications to emissions from coal-fired utility boilers." *Progress in Energy and Combustion Science*, 26(4), 507-531.
- Müller, H. (2002). "Sulfuric acid and sulfur trioxide." Ullman's encyclopedia of industrial chemistry, Wiley-VCH Verlag GmbH & CO., Weinheim.
- Mönckert, P., Reber, D., Maier, J., and Scheffknecht, G. (2007a). "Operation of a Retrofitted 0.5 MW_{th} PF Combustion Facility under Oxyfuel Conditions - An Experience Report." *32nd International Technical Conference on Coal Utilization and Fuel Systems*, Clearwater.
- Mönckert, P., Reber, D., Maier, J., and Scheffknecht, G. (2007b). "Properties of nitrogen oxide during oxyfuel burning with flue gas recirculation." *VDI-Berichte*, 81-88.
- Nakayama, S., Noguchi, Y., Kiga, T., Miyamae, S., Maeda, U., Kawai, M., Tanaka, T., Koyata, K., and Makino, H. (1992). "Pulverized coal combustion in O₂/CO₂ mixtures on a power plant for CO₂ recovery." *Energy Conversion and Management*, 33(5-8), 379-386.
- Nozaki, T., Takano, S. I., Kiga, T., Omata, K., and Kimura, N. (1997). "Analysis of the flame formed during oxidation of pulverized coal by an O₂-CO₂ mixture." *Energy*, 22(2-3), 199-205.
- Okazaki, K., and Ando, T. (1997). "NO(x) reduction mechanism in coal combustion with recycled CO₂." *Energy*, 22(2-3), 207-215.
- Park, D. C., Day, S. J., Nelson, P. F., and Molina, A. (2005). "Nitrogen release during reaction of coal char with O₂, CO₂, and H₂O." *30th International Symposium on Combustion*, Chicago, 2169-2175.
- Pershing, D. W., and Wendt, J. O. L. (1979). "Relative contributions of volatile nitrogen and char nitrogen to NO_x emissions from pulverized coal flames." *Industrial & Engineering Chemistry Process Design and Development*, 18(1), 60-67.
- Prentice, A. L., and Allam, R. J. (1992). "Carbon dioxide and acid gas removal and recovery process for fossil fuel fired power plants." Air Products.
- Rasmussen, C. L., Geest Jakobsen, J. O. N., and Glarborg, P. (2008a). "Experimental measurements and kinetic modeling of CH₄/O₂ and CH₄/C₂H₆/O₂ conversion at high pressure." *International Journal of Chemical Kinetics*, 40(12), 778-807.
- Rasmussen, C. L., Hansen, J., Marshall, P., and Glarborg, P. (2008b). "Experimental measurements and kinetic modeling of CO/H₂/O₂/NO_x conversion at high pressure." *International Journal of Chemical Kinetics*, 40(8), 454-480.
- Rasmussen, C. L., Rasmussen, A. E., and Glarborg, P. (2008c). "Sensitizing effects of NO_x on CH₄ oxidation at high pressure." *Combustion and Flame*, 154(3), 529-545.

- Rasmussen, C. L., Wassard, K. H., Dam-Johansen, K., and Glarborg, P. (2008d). "Methanol oxidation in a flow reactor: Implications for the branching ratio of the $\text{CH}_3\text{OH}+\text{OH}$ reaction." *International Journal of Chemical Kinetics*, 40(7), 423-441.
- Rathnam, R. K., Elliott, L. K., Wall, T. F., Liu, Y., and Moghtaderi, B. (2009). "Differences in reactivity of pulverised coal in air (O_2/N_2) and oxy-fuel (O_2/CO_2) conditions." *Fuel Processing Technology*, 90, 797-802.
- Rota, R., Bonini, F., Servida, A., Morbidelli, M., and Carrá, S. (1997). "Modeling of the reburning process." *Combustion Science and Technology*, 123(1-6), 83-105.
- Shaddix, C. R., and Murphy, J. J. (2003). "Coal Char Combustion Reactivity in Oxy-Fuel Applications." *The 20th International Pittsburgh Coal Conference*, Pittsburgh, PA USA.
- Skreiberg, Ö., Kilpinen, P., and Glarborg, P. (2004). "Ammonia chemistry below 1400 K under fuel-rich conditions in a flow reactor." *Combustion and Flame*, 136(4), 501-518.
- Sloss, L. L. (2003). *Trends in emission standards*, IEA Coal Research, London, Great Britain.
- Smith, G. P., Golden, D. M., Frenklach, M., Moriarty, N. W., Eiteneer, B., Goldenberg, M., Bowman, C. T., Hanson, R. K., Song, S., Jr., W. C. G., Lissianski, V. V., and Qin, Z. 1999. "GRI-Mech 3.0." http://www.me.berkeley.edu/gri_mech/
- Taber, J. J. (1985). "Fate of small concentrations of SO_2 , NO_x , and O_2 when injected with CO_2 into oil reservoirs." *ANL/CNSV-50*, Argonne National Laboratory, Argonne.
- Tan, Y., Croiset, E., Douglas, M. A., and Thambimuthu, K. V. (2006). "Combustion characteristics of coal in a mixture of oxygen and recycled flue gas." *Fuel*, 85(4), 507-512.
- Thiemann, M., Scheiber, E., and Wiegand, K. W. (2002). "Nitric acid, nitrous acid and nitrogen oxides " Ullman's encyclopedia of industrial chemistry, Wiley-VCH Verlag GmbH & CO., Weinheim.
- Tian, Z., Li, Y., Zhang, L., Glarborg, P., and Qi, F. (2009). "An experimental and kinetic modeling study of premixed $\text{NH}_3/\text{CH}_4/\text{O}_2/\text{Ar}$ flames at low pressure." *Combustion and Flame*, 156(7), 1413-1426.
- Toporov, D., Bocian, P., Heil, P., Kellermann, A., Stadler, H., Tschunko, S., Förster, M., and Kneer, R. (2008). "Detailed investigation of a pulverized fuel swirl flame in CO_2/O_2 atmosphere." *Combustion and Flame*, 155(4), 14.
- Van Der Lans, R. P., Glarborg, P., and Dam-Johansen, K. (1997). "Influence of process parameters on nitrogen oxide formation in pulverized coal burners." *Progress in Energy and Combustion Science*, 23(4), 349-377.
- Wendt, J. O. L., Sternling, C. V., and Matovich, M. A. (1973). "Reduction of sulfur trioxide and nitrogen oxides by secondary fuel injection." *Symposium (International) on Combustion*, 14(1), 897-904.

- White, V., Torrente-Murciano, L., Sturgeon, D., and Chadwick, D. (2010). "Purification of oxyfuel-derived CO₂." *International Journal of Greenhouse Gas Control*, 4(2), 137-142.
- Woycenko, D. M., van de Kamp, W. L., and Roberts, P. A. (1995). "Combustion of pulverized coal in a mixture of oxygen and recycled flue gas, summary of the APG research program." *IFRF Doc/F98/Y/2*, Ijmuiden, Netherlands.
- Wu, Z. (2005). *Fundamentals of pulverised coal combustion*, IEA Clean Coal Centre, London.
- Zeldovich, Y. B. (1946). "The oxidation of nitrogen in combustion and explosions." *Acta Physicochimica USSR*, 21, 577-628.
- Zheng, L., and Furimsky, E. (2003). "Assessment of coal combustion in O₂+CO₂ by equilibrium calculations." *Fuel Processing Technology*, 81(1), 23-34.

PAPER I