



CHALMERS
UNIVERSITY OF TECHNOLOGY

Function modelling and constraints replacement for additive manufacturing in satellite component design

Downloaded from: <https://research.chalmers.se>, 2020-07-11 08:51 UTC

Citation for the original published paper (version of record):

Borgue, O., Müller, J., Panarotto, M. et al (2018)

Function modelling and constraints replacement for additive manufacturing in satellite component design

Proceedings of NordDesign: Design in the Era of Digitalization, NordDesign 2018

N.B. When citing this work, cite the original published paper.

See discussions, stats, and author profiles for this publication at: <https://www.researchgate.net/publication/327270210>

Function modelling and constraints replacement to support design for additive manufacturing of satellite components

Article · August 2018

CITATIONS

0

READS

107

4 authors:



Olivia Borgue

Chalmers University of Technology

2 PUBLICATIONS 0 CITATIONS

[SEE PROFILE](#)



Jakob Ramon Müller

Chalmers University of Technology

6 PUBLICATIONS 2 CITATIONS

[SEE PROFILE](#)



Massimo Panarotto

Chalmers University of Technology

20 PUBLICATIONS 52 CITATIONS

[SEE PROFILE](#)



Isaksson Ola

Chalmers University of Technology

111 PUBLICATIONS 678 CITATIONS

[SEE PROFILE](#)

Some of the authors of this publication are also working on these related projects:



ProViking THINK - Teams for Heterogeneous Innovation Knowledge [View project](#)



METOPIA - Methodology for Optimization, Integration and Automatization [View project](#)

Function modelling and constraints replacement to support design for additive manufacturing of satellite components

Olivia Borgue¹, Jakob Muller², Massimo Panarotto³, Ola Isaksson⁴

Chalmers University of Technology

¹ *borgue@chalmers.se*

² *jakob.muller@chalmers.se*

³ *massimo.panarotto@chalmers.se*

⁴ *ola.isaksson@chalmers.se*

Abstract

Additive Manufacturing is increasingly attracting interest among manufacturers of space components, mainly due to its high design freedom, capability for achieving weight reduction and for being cost-efficiently produced in low volumes. However, AM is a less mature technology compared to established manufacturing methods. This lack of maturity concerns especially the area of AM manufacturing constraints as the knowledge about them is limited and because they mature over time, as the technology evolves. The lack of knowledge hinders designers to fully take advantage of AM, fearing that the technology will affect product reliability. This situation is particularly emphasized in space components, since they are subject to high reliability requirements.

In this paper, a methodology based on function decomposition and constraint modelling is proposed as a basis for re-design of products using AM. In the methodology, the original functions, design solutions and manufacturing constraints of a product are identified. Then, the original manufacturing constraints are removed and replaced with manufacturing constraints for AM. Afterwards, functions and design solutions on the function model are modified and a new part geometry is designed and eventually realised in CAD.

This methodology has been applied on a case study featuring a satellite sub-component.

Keywords: *Function modelling, AM, functional decomposition, manufacturing constraints, DfAM*

1 Introduction

Product development for space applications must cope with high reliability requirements related with the extreme conditions in rocket launch and satellite operations. Moreover, there is a constant pressure to achieve lightweight and cost-efficient designs of space components (Castet & Saleh, 2009). In this context, Additive Manufacturing (AM) is a promising technology for space applications. Taking

advantage of the unprecedented design freedom that AM allows (Rosen, 2014), space products can be designed to achieve both weight reduction as well as performance increase (Yang, Tang & Zhao, 2016). These advantages can be achieved by the fact that the constraints imposed from previously used manufacturing processes (machining, casting, etc.) can be removed, hence allowing unprecedented design freedom. However, AM also introduces new constraints, such as minimum manufacturable wall thickness (EOS, 2018) which have yet to be fully explored (Thompson et al., 2016). As a result, product developers face a dilemma: 1) either they focus on creating new designs for AM with a limited awareness about AM constraints, jeopardizing product reliability or 2) they focus on creating overconservative designs, losing the design freedom that characterizes AM. The challenge this dilemma represents is emphasized by the fact that AM constraints are maturing over time, as the knowledge about them matures as well as the technology. Therefore, this article explores the research question:

RQ: How can products be redesigned for AM, considering AM design freedom as well as manufacturing constraints?

This study starts from the premise that when introducing new technologies or manufacturing methods, the design process rarely starts from scratch. Building on the design knowledge of previous products and well-known versions helps maintaining reliability and quality and aids the process of validation through a transfer of design knowledge (Pahl, Beitz, Feldhusen, & Grote, 2007). Hence, AM designs and constraints could be modelled against previous product knowledge, where product function and features were designed considering previously used manufacturing technologies (machining, casting, etc.), hence allowing a more effective technique for design AM. The outcome of this study is therefore a design methodology for taking advantage of AM design freedom, while considering manufacturing constraints early in the design phase. This methodology implements function modelling with a constraint modelling strategy that systematically replaces the constraints from previously implemented manufacturing methods with AM specific constraints. For illustrating the methodology, a case study featuring the redesign of a satellite component is presented.

2 Background

Based on the mentioned challenge of taking advantage of AM design freedom while taking into account AM constraints, two different Design for Additive Manufacturing (DfAM) approaches have already been identified in literature (Boyard, 2015): on one hand “opportunity-driven” methods, that focus on the opportunities brought by AM regarding design freedom, aiming to generate innovative geometries with new functionality and solutions, disregarding manufacturability (Campbell, Bourell & Gibson, 2012); and on the other hand “manufacturing driven” methods, that maintain the existing shape and function of a product and merely do minimal changes to comply to manufacturing constraints of AM (Thompson et al., 2016). While the two approaches initially seem to be exclusive, they can as well be combined. For example, to make use of AM design freedom, as well as for providing a DfAM method, Boyard, Rivette, Christmann & Richir (2013) use a functional decomposition into simple node graphs for the design of new products. These are then matched to a library of similar graphs to help ease the design process. The authors consider manufacturing constraints, but their assessment has still to be done manually through an expert panel. The approach of a function model is also pursued by Salonitis (2016), who bases the redesign for AM process on Axiomatic Design by Suh (1990) and uses design guidelines based on questionnaires to ensure manufacturability early on in the design process.

However, no approach has been found which explicitly considers the impact of a change in the manufacturing method to AM on both the design freedom as well as the manufacturing related constraints, or even tries to describe and model these constraints. In the context of redesign for AM, where the knowledge about AM constraints is limited and constantly evolving, modelling constraints can help to systematically and efficiently manage and use that knowledge.

One product modelling technique that helps addressing design freedom while modelling design constraints is Enhanced Function-Means modelling (EF-M). Function modelling is among the most popular modelling techniques for DfAM (Borgue, Panarotto & Isaksson, 2018) as it provide an abstract method for representing an overall product architecture to help guiding design activities through mapping the design space (Hirtz, Stone, Mcadams, Szykman & Woods, 2002). By understanding the product architecture, a designer can easily identify where and to which extent AM design freedom may be relevant for the product.

EF-M is a function modelling technique that provides a hierarchical product structure (Johannesson & Claesson, 2005) that associates design solutions (DS) with their driving functional requirements (FR), using a “is solved by” (isb) connection. In this technique, DS can be subject to design constraints (C), via “is constrained by” (icb) connections and each DS can then be detailed into further FR and respective DS via “requires function” (rf) connections. If the constraint of a top-level is partially met by (ipmb) a subordinate DS, this is also mapped in the model. Moreover, design solutions can be modelled on their interaction with (iw) each other via geometry, signals, energy or material flow.

These connections are captured in the EF-M model, illustrating the complexity of the product and the impact of design decisions. The mentioned modelling elements are illustrated in Figure 1.a. The design rationale that is created through this structure iterates between FR and DS through the different levels, from the stakeholder needs on the static level to the concrete level, which represents the DS closest to the product geometry. This structure, illustrated in Figure 1.b, allows to identify the impact of constraints, as well how a change in a function or constraint affects the product structure. Moreover, to enable a segmentation of the product structure, Configurable Components (CC) are implemented in EF-M as well. CC, introduced by Claesson (2006), are objects that encapsulate an entire branch (DS and sub-elements) of an EF-M tree, as shown in colours in Figure 1b.

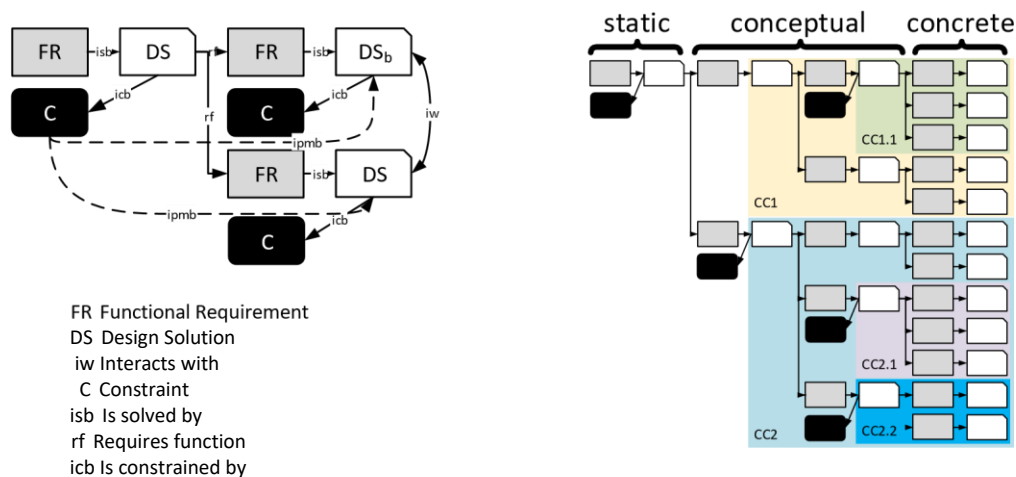

a) b)
Figure 1. EF-M modelling, a) modelling elements, based on (Johannesson & Claesson, 2005) and b) levels of EF-M tree based on (Levandowski, Michaelis, & Johannesson, 2014) and encapsulation through CC.

EF-M was chosen to build the methodology implemented in this article since it provides a distinct modelling of constraints, CC were incorporated as well as they enable a modular- or platform design where the CC can be exchanged or explored alternatively. This publication uses only the encapsulation into modules, which is a fraction of the CC theory, and hence refrains from a detailed explanation of the method. Even if the authors of this article selected EF-M to develop the presented methodology, they acknowledge the existence of other modelling

strategies like the one proposed by Weilkiens using the description language SysML combined with modelling tools like UML (Chesnut, 1967; Weilkiens, 2007), the widely applicable function-behaviour-state model (FBS) for modelling a system with its functional descriptions (Umeda, Takaeda & Tomiyama, 1990; Takaeda 1994), or the functions template strategy adopted by Heller & Feldhusen (2014) for creating unambiguous function structures.

3 Method

The results presented in this article are based on the results of a project held in cooperation with three Swedish suppliers of space components, with the objective of demonstrating the feasibility of introducing and qualifying additive manufacturing technologies in space applications. The research adopted an action research (Avison, Lau, Myers, & Nielsen, 1999) approach, featuring several workshops attended by industrial practitioners from the participating companies. The first step was a proposition of case studies, from all the involved companies, of a product to be redesign for AM. From the “as-is” CAD representation of the products, a functional decomposition into FR and DS was performed.

After this process, function trees were made and then verified by the industrial specialists. From the three representative products, significant design features were extracted and combined in the case study presented in this article (to both protect company-sensitive information and to show the methodology rather than the technical detailed of the case studies). The case study features a propellant flow connector and was verified in terms of fidelity with the industry specialists. The EF-M model of the propellant flow connector has been created in the same fashion as in the workshops described above.

4 Proposed Strategy

As stated in previous sections, the proposed modelling strategy of design for AM is based on functional decomposition using EF-M. The methodology is divided into three main phases:

1. The EF-M model is constructed from the original part with the inclusion of the original manufacturing constraints.
2. The original manufacturing constraints are removed from the EF-M tree.
3. AM constraints are introduced, and the part is redesigned.

Phase 1: Functional decomposition

In an initial step, an EF-M tree of the original part is built to facilitate the understanding of the product architecture. For building the EF-M tree, the part geometry is analysed to find the functions directly associated to individual features. Those functions are then denoted as FR, and the respective features as DS. This initial identification creates the concrete level of the EFM tree. Then, *constraints* (C) having an impact on the DS are identified and noted with icb connections relative to the DS. In this methodology, a distinction is made between *Manufacturing constraints* (C_m) that depend on the manufacturing process, like minimum manufacturable wall thickness, and *Functional constraints* (C_f) that depend on functional requirements, like the maximum pressure a pipe needs to endure. This distinction is a crucial part of the methodology presented in this study, which extends the original EF-M method (which does not distinguish between different types of constraints). Differentiating between C_f and C_m , facilitates the process of identifying the DS in the design that are only manufacturing dependent, and that can therefore, be targeted to be redesign for AM.

This phase has to be performed in close collaboration with designers and specialists with vast knowledge about the product and manufacturing processes involved, in order to accomplish an accurate function tree.

Phase 2: Freeing up the design space

Building on the EF-M tree from Phase 1, the manufacturing constraints, C_m , are highlighted, and their impact on the DS is assessed. C_m that are derived from manufacturing methods such as machining which will be replaced by AM and the DS (and their respective sub-trees) constrained by them are pruned from the function tree. Furthermore, DS that interact with DS from the removed branches are also highlighted, since their geometry might as well be free to be re-designed.

Phase 3: Re-design for AM

In this phase, the constraints related to the AM method that is to be used are introduced in the place where the original manufacturing constraints have been removed. These constraints are AM-process specific and must be assessed by experts. During the workshops with industrial practitioners, was emphasized the need of a close collaboration with AM suppliers or AM researchers for gaining knowledge about AM constraints.

The sub-branches removed on the previous phase are now re-constructed with new DS under consideration of the AM constraints, making use of the explicitly freed up design space. Through this, a new function tree of a new design is built, and a new geometry can be conceived.

5 Case Study: applying the proposed methodology on a flow connector

The propellant flow connector addressed in this article is a pipe structure connecting two interfaces of different shape and dimension. The main function is to guide a fluid, which has a maximum pressure of 300bar. The connector has two interfaces, a circular inlet, and a rectangular outlet, to which it is connected via welding. The shape and dimension of both interfaces, as well as the fixation interface towards the satellite are illustrated in Figure 2.

In its current form, the outer shape is machined from a titanium block, the vertical tube is manufactured through drilling, and the horizontal one is milled from the bottom. The cavity resulting from this process is welded shut with a plate, in which two “ears” for screwing onto the satellite are integrated. The flow connector is redesigned to be manufactured with the AM method direct metal laser sintering (DMLS).

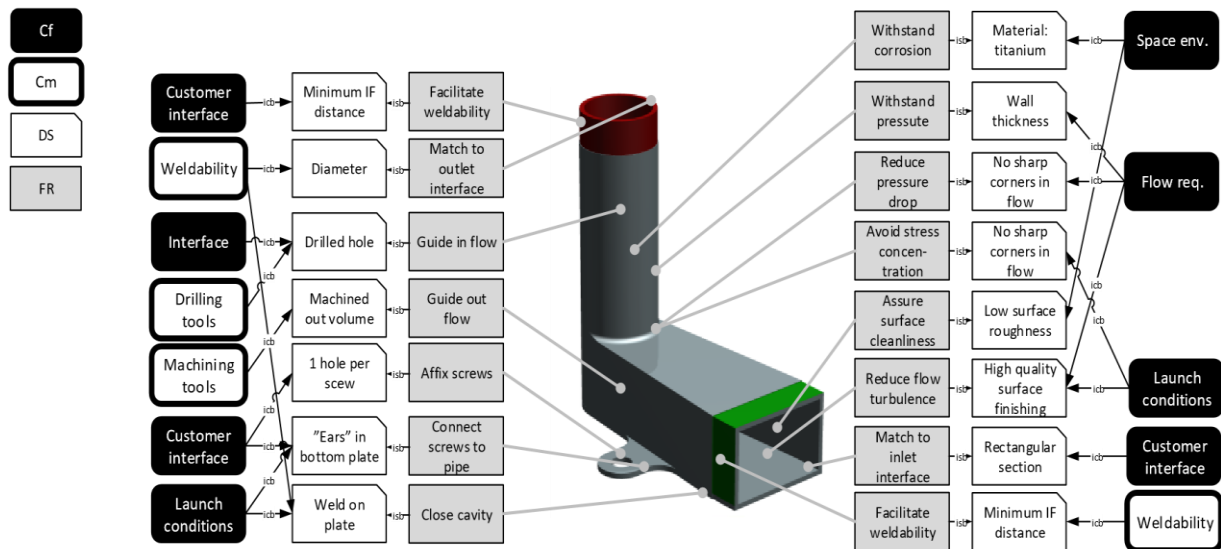

Figure 2. Original propellant flow connector geometry with assigned FR and DS, and respectively identified C. Cm are made distinguishable in white with thick borders
Functional decomposition

As detailed in Section 4, the first step is to do the functional decomposition of the propellant flow connector. Based on the available geometry of the part, the FR and DS on the concrete level are identified as shown in Figure 2. Furthermore, all constraints that affect the design of the respective feature are identified and connected to the DS. In a next step, the FR of the static level are identified as “*Guide fluid from inlet to outlet*” and “*Attach to satellite*”. The concrete level DS and FR are grouped under these main functions and the conceptual level of the tree is filled in, as shown in Figure 3.

DS that interact with each other either geometrically, energetically, in signals or material flow are connected by iw connectors indicating the direction of the impact. Lastly, the constraints (both Cf and Cm) are placed on the EF-M tree and connected to the respective DS through icb connections. In Figure 3, the constraints are regrouped as compared to Figure 2, to conform to the EF-M modelling conventions where a top-level constraint can be partially met by (ipmb) the respective sub-DS. While attempted to be as methodologically correct as possible, not all ipmb and iw connectors are shown in Figure 3 to reduce the model complexity for readability purposes.

Lastly, the EF-M tree is encapsulated into different CC (tube, outlet, inlet and satellite interface) to ease the identification and substitution process, shown in coloured boxes in Figure 3.

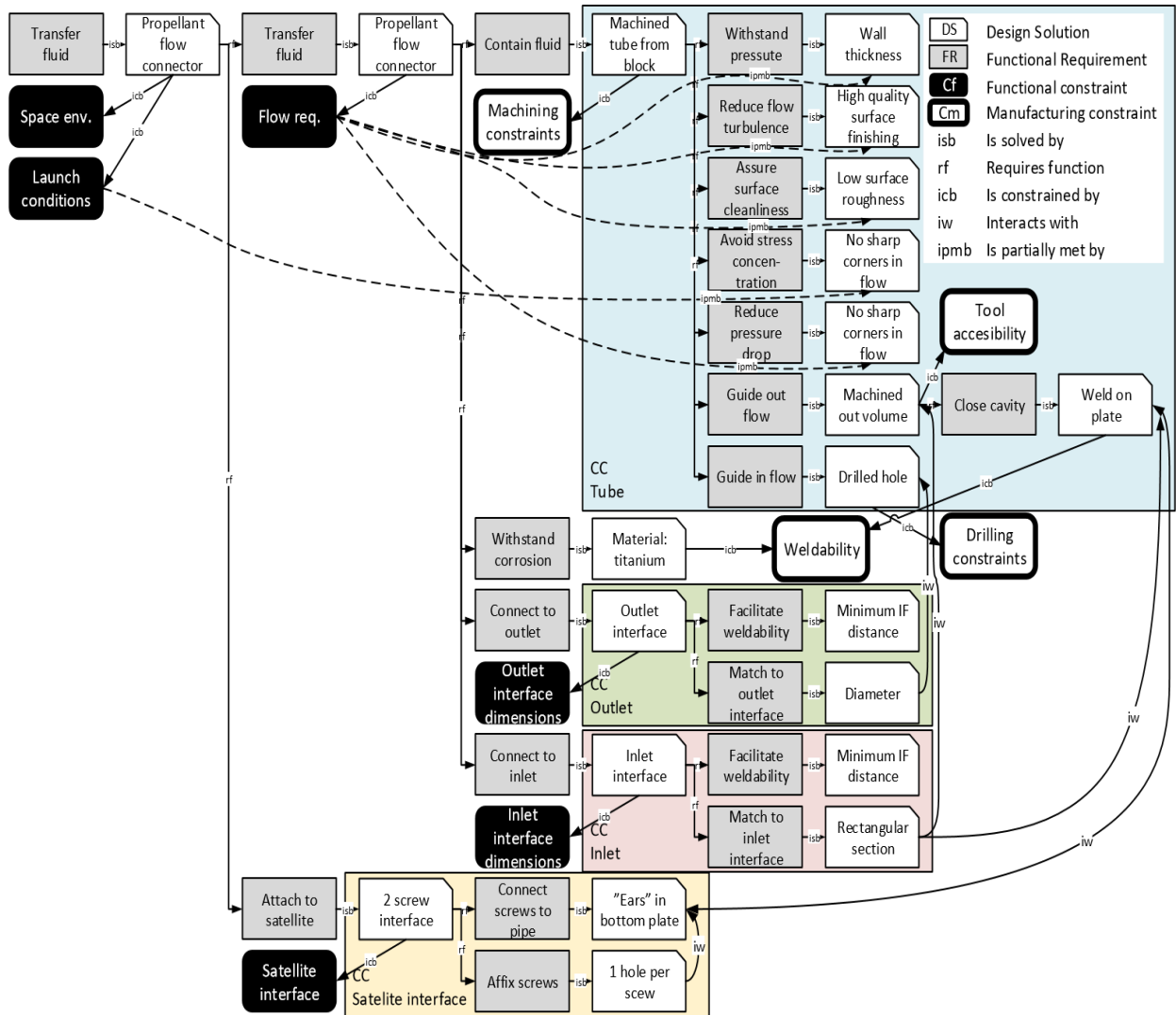

Figure 3. Functional decomposition of the propellant flow connector. “iw” and “ipmb” connectors are only modelled to the extent needed for the demonstration to keep the graph readable.

Constraint replacement

The constraints illustrated in Figure 3 are both functional and manufacturing constraints. Since the weld connection towards the system level cannot be changed, the respective Cm must be remained untouched. The Cm “*Machining constraints*” however, constraining the CC “*Tube*”, can be removed due to the change in manufacturing systems towards AM. This frees the design space for the entire CC “*Tube*”. Due to the iw connection from the DS “*Weld on place*” in the CC “*Tube*” to the DS “*Ears in bottom plate*” in the CC “*Satellite interface*”, this CC is impacted by the design change as well and is free to be redesigned. Therefore, the product geometry available for redesign is the entire presented in Figure 2 except for the interface geometries, which are highlighted in green and red.

In Figure 3, the CC corresponding to the interfaces, that remain unchanged, are also highlighted in green and red respectively. For the process of constraints replacement, Table 1 lists an assortment of the machining and AM constraints considered in this case study. In Table 1, the machining constraint “*Max. depth/diameter ratio (drilled holes)*” cannot be evaluated for DMLS (- sign) and, instead is considered the DMLS constraint “*Max. height/wall thickness*”.

As the constraints are related to the AM process chosen, different AM processes present different constraint, in this article the AM process chosen is DMLS and the considered constraints are DMLS constraints.

Table 1. Constraints for machining and DMLS compared. The sign “-” means that the constraint is not applicable to the technology. Retrieved from (Customparts, 2018; Hassanin et al., 2018; EFunda, 2018; EOS, 2018).

Constraint nature	Machining	DMLS
Achievable tolerances (mm)	$\pm 0,13$	$\pm 0,25$
Achievable surface roughness, Ra (μm)	0,20 – 12,7	5 - 20
Max. depth/diameter ratio (drilled holes)	< 3	-
Min. hole diameter (mm)	0,05	0,5
Max. height/wall thickness	-	40
Min. wall thickness (mm)	0,10	0,4
Min. pocket size (mm)	0,05	0,5

Redesign for AM

After the removal of the Cm limiting the DS “*Machined tube from block*” and the corresponding tree branch, the new DS “*AM tube*” is placed as solution to the FR “*Contain flow*”. This functional requirement is now satisfied by the new DS, which is constrained by the Cm “*AM constraints*”.

AM design freedom allows redesigning a geometry that, still fulfilling the FR, can aim at an increased efficiency. For this reason, the design is based on physics models, creating a curved connector shape with a smooth change in cross section. This shape aims to connect the unmodified inlet and outlet interfaces while minimizing energy losses on the fluid, based on the models shown by Fox et al. (2016). The respective FR and DS are illustrated in the CC “*AM tube*” in Figure 4. The connectors for attaching the propellant tube to the satellite interface are integrated into the tube structure and have been redesigned using topology optimisation for creating a lightweight and functional geometry. The implementation of topology optimization in the DS is constrained by “*DMLS minimum pocket size*” and “*DMLS minimum wall thickness*”. This is illustrated in the CC “*Satellite interface*” in the DS “*Topology optimised foot*”, shown in Figure 4. The result of the redesign is a new geometry that fulfils the same top-level functional requirements. This is shown by keeping the same static level in the EF-M tree and only changing conceptual and concrete DS and CC. This method also highlighted which geometries can be redesigned, and which should remain untouched such as the interface geometries.

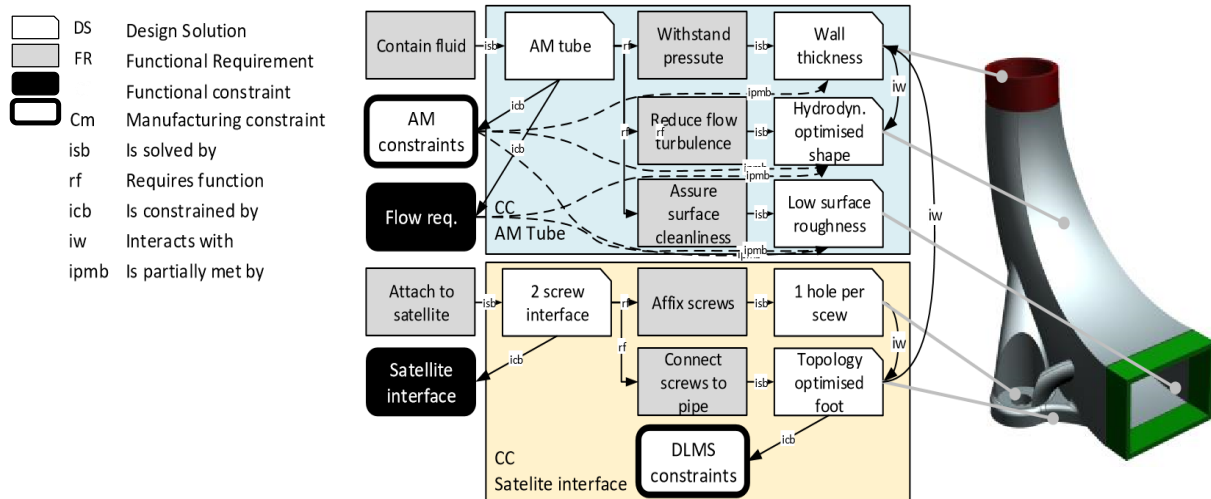

Figure 4. Redesign of the propellant flow connector, shown by the EF-M of the two redesigned CC “AM tube” and “Satellite interface” together with the new geometry. Note that in the CC Satellite interface only the DS “Topology optimised foot” is new.

6 Discussion

The methodology illustrated in this article introduces a constraints replacement strategy for the redesign of components to be manufactured with AM based on Enhanced Function-Means modelling. The case study presented is a satellite component inspired by space products to be redesigned for AM, which have been analysed during workshops with practitioners from the space industry. The approach developed, focuses on actively considering manufacturing constraints in a function modelling strategy, for systematically freeing the design space for new designs. To enable this, a distinction between *functional constraints* (Cf) and *manufacturing constraints* (Cm) has been introduced. This distinction facilitates the process of identifying the DS in the design that are only manufacturing dependent (Those DS constrained by a Cm), and that can therefore, be redesign for AM.

The constraint replacement procedure was combined with the use of CC for delimitating and distinguishing between the sections of the product aimed to be redesigned and those aimed to remain intact. This clear delimitation was useful for taking advantage of AM design freedom and for implementing physics models for achieving a theoretically more efficient shape for the satellite component.

The nature of the modelling tool (function modelling) selected for this methodology suggest that the methodology can be generalized to any product to be redesign and to any new manufacturing process that wants to be implemented. Generalizability, in this sense, lies on the possibility of customizing the function tree representation with information about any product of interest. Moreover, the methodology is presented as versatile enough for modifying (or including new) AM manufacturing constraints, as the knowledge about them evolves.

Function modelling and geometry

The connection from geometry to function model is initially created through the function decomposition, and in this attempt to capture all function relevant design solutions in the concrete level of the EF-M model. However, the full extent of the newly generated design freedom on the geometric domain, where the re-design is eventually going to happen, cannot be illustrated. This would require the method to provide a dedicated Function Model –

Geometry Model (CAD) interface. Although initial research about coupling EF-M to geometry has been conducted by e.g. Raudberget, Landahl, Levandowski & Müller (2016), the application is still rudimentary and requires further investigation. Other approaches like, for example, from Raja & Isaksson (2015) do not come close to this level of function-geometry matching needed in this approach, either.

However, the feature-based function assignment presented in phase one provides a step closer towards this connection. Individual geometric entities are assigned their respective function, providing an isolation of the function-relevant geometry. This can be useful e.g. in function model-based design space exploration approaches, where function specific geometry needs to be assessed, edited, and evaluated.

7 Conclusion

In this article, a novel methodology of function modelling with special focus on manufacturing constraints for redesign for AM is presented. The methodology is based in functional decomposition combined with a constraint modelling strategy, the approach proposes a distinction between Cf, functional constraints, and Cm, manufacturing constraints. The constraint modelling strategy was also combined with the use of CC for delimitating and distinguishing between the sections of the product aimed to be redesigned and those aimed to remain intact. This clear delimitation is useful for taking advantage of AM design freedom and using physics models and topology optimization for achieving a theoretically more efficient shape for the satellite component.

The approach has been applied in a case study featuring a satellite component. The chosen function modelling method, Enhanced Function-Means modelling, is suitable due to its hierarchical product structure, that provides a clear understanding of the product architecture, and its possibility of modelling constraints. Future research must be concerned with the connection between FM and geometry model.

Acknowledgments

The authors gratefully acknowledge the financial support from the Swedish National Space Technology Research Program (NRFP) and the Swedish aerospace companies participating on the workshops for the RIQAM project that made possible the data collection needed for the empirical study.

8 References

- Avison, D., Lau, F., Myers, M., & Nielsen, P. (1999). Action Research. *Magazine Communications of the ACM*, 42(1), 94-97. doi: 10.1145/291469.291479.
- Borgue O., Panarotto M. & Isaksson O. (2018). Impact on design when introducing additive manufacturing in space applications. *15th International Design Conference (pp. 997-1008)*, Dubrovnik, Croatia. doi: 10.21278/idc.2018.0412.
- Boyard N., Rivette M., Christmann O., & Richir S. (2013). A design methodology for parts using additive manufacturing. *International Conference on Advanced Research in Virtual and Rapid Prototyping VRAP* (pp. 0-6.), Leiria, Portugal. HAL-01197463. doi: 10.1201/b15961-74
- Boyard N. (2015). *Méthodologie de conception pour la réalisation de pièces en Fabrication Additive* (doctoral dissertation). l'École Nationale Supérieure d'Arts et Métiers Spécialité “ Génie mécanique - procédés de fabrication”, Paris, France.

- Campbell, I., Bourell, D., & Gibson, I. (2012). Additive manufacturing : rapid prototyping comes of age. *Rapid Prototyping Journal*, 18(4), 255-258. doi: <https://doi.org/10.1108/13552541211231563>
- Castet J., & Saleh J. (2009). Satellite Reliability: Statistical Data Analysis and Modeling. *Journal of Spacecraft and rockets*, 46(5), 1165-1076. doi: <https://doi.org/10.2514/1.42243>
- Chestnut, H. (1967). *Systems Engineering Methods*. New York, London, Sydney: Wiley.
- Claesson, A. (2006). *A configurable component framework supporting platform-based product development* (doctoral dissertation). Chalmers University of Technology, Gothenburg, Sweden.
- Customparts, Milling .(2018). Retrieved from <http://www.custompartnet.com/wu/milling>
- Efunda, Drilled Part Design .(2018). Retrieved from http://www.efunda.com/processes/machining/drill_design.cfm
- EOS, Additive Manufacturing (AM) Basic Design Rules for Additive Manufacturing. (2018). Retrieved from https://cdn1.scrvt.com/eos/public/ab4f0542d66453fc/5f889ab7e3f72bd3d44b22205ba8b68b/EOS-Basic-Design-Rules_Additive-Manufacturing_EN.pdf
- Fox R., McDonald A., & Pritchard P. (2006)., *Introduction to fluid mechanics,6th Edition JustAsk!*. John Wiley & Sons Inc.
- Hassanin H., Elshaer A., Benhadj-Djilali R., Modica F., & Fassi I. (2018). Surface Finish Improvement of Additive Manufactured Metal Parts. In K. Gupta, Springer International Publishing AG 2018, *Micro and Precision Manufacturing, Engineering Materials book series* (pp. 145-164). doi: https://doi.org/10.1007/978-3-319-68801-5_7.
- Heller J., Feldhusen J. (2013). Enhanced function structure applicability through adaptive function templates. Athens: ATINER'S Conference paper series, No: IND2013-0743
- Hirtz J., Stone R., Mcadams D. , Szykman S., & Woods K. (2002). A functional basis for engineering design: reconciling and evolving previous efforts. *Research in engineering design*,13, 65-82. doi: 10.1007/s00163-001-0008-3.
- Johannesson, H., & Claesson, A. (2005). Systematic product platform design: A combined function-means and parametric modeling approach. *Journal of Engineering Design*, 16(1), 25–43. doi: <https://doi.org/10.1080/09544820512331325247>.
- Levandowski, C., Michaelis, M., & Johannesson, H. (2014). Set-based development using an integrated product and manufacturing system platform. *Concurrent Engineering*, 22(3), 234–252. doi: <https://doi.org/10.1177/1063293X14537654>
- Lindwall, A., Dordlofva, C., & Öhrwall Rönnbäck, A. (2017). Additive manufacturing & the product development process: Insights from the space industry. *Proceedings of the 21st International Conference on Engineering Design (ICED 2017)* (pp. 345–354), Vancouver, Canada.
- Pahl, G., Beitz, W., Feldhusen, J., Grote, K. (2006). *Engineering design, a systematic approach*. Springer-Verlag London.
- Raja, V., & Isaksson, O. (2015). Generic Functional Decomposition of an Integrated Jet Engine Mechanical Sub System Using a Configurable Component Approach. *Transdisciplinary Lifecycle Analysis of Systems*, 337-346. doi:10.3233/978-1-61499-544-9-337.
- Raudberget, D., Landahl, J., Levandowski, C., & Müller, J. (2016). Bridging the gap between functions and physical components through a structured functional mapping chart. *Proceedings of the 2016 ISPE International Conference on Transdisciplinary Engineering* (pp. 107-116), Curitiba, Brazil. doi: <https://doi.org/10.3233/978-1-61499703-0-107>.

- Rosen, D. (2014). Design for Additive Manufacturing: Past, Present, and Future Directions. *Journal of Mechanical Design*, 136(9). doi: 10.1115/1.4028073.
- Salonitis, K. (2016). Design for additive manufacturing based on the axiomatic design method. *International Journal of Advanced Manufacturing Technology*, 87(1–4), 989–996. <https://doi.org/10.1007/s00170-016-8540-5>
- Suh, N. P. (1990). *The principles of design*. Oxford, England. Oxford University Press Inc.
- Thompson, M., Moroni, G., Vaneker, T., Fadel, G., Campbell, R., Gibson, I. & Martina, F. (2016). Design for Additive Manufacturing: Trends, opportunities, considerations, and constraints. *CIRP Annals - Manufacturing Technology*, 65(2), 737–760. <https://doi.org/10.1016/j.cirp.2016.05.004>.
- Umeda, Y., Takeda, H., & Tomiyama, T. (1990). Function, Behaviour and Structure. *Applications of artificial intelligence in engineering*, 177–194. Berlin: Springer.
- Yang S., Tang J. & Zhao Y. (2016). Assembly-level design for additive manufacturing: issues and benchmark. ASME. *Proceedings of the ASME 2016 International Design Engineering Technical Conferences and Computers and Information in Engineering Conference IDETC/CIE 2016*, Charlotte, North Carolina.
- Weilkiens, T. (2007). *Systems engineering with SysML/UML: Modeling, analysis, design*. Amsterdam, Boston: Elsevier.