

THESIS FOR THE DEGREE OF LICENTIATE OF ENGINEERING

# Towards Supervisory control for complex Propulsion subsystems

WITH LOOK AHEAD INFORMATION

DHINESH VELMURUGAN



**CHALMERS**

Department of Electrical Engineering  
CHALMERS UNIVERSITY OF TECHNOLOGY  
Göteborg, Sweden 2018

Towards Supervisory control for complex Propulsion subsystems  
with Look ahead information

DHINESH VELMURUGAN

© DHINESH VELMURUGAN, 2018.

Technical report number: R016/2018

ISSN 1403-266X

Department of Electrical Engineering  
CHALMERS UNIVERSITY OF TECHNOLOGY  
SE-412 96 Göteborg, Sweden

Typeset by the author using L<sup>A</sup>T<sub>E</sub>X.

Chalmers Reproservice  
Göteborg, Sweden 2018

To my family



# Abstract

Powertrain subsystem complexity has been on the rise with increasing legal requirements and meeting disruptive market trends. There is greater potential for cost efficient robust operation with integrated control units and software development. For systems that are interdependent, operating towards the common goal of fuel optimal operation under controlled exhaust emissions, it would be natural to integrate controls using a supervisory controller with a holistic overview of subsystem operation that utilised synergies and optimal trade-offs.

Connected cars have grown exponentially owing to consumer demand which offers rich data on vehicle operation and enables the possibility of tailoring systems to individual optimum operation. The possibility to feed external data, such as traffic information combined with the specific vehicle historic operation, enables prediction of the future vehicle trip and operating condition with greater accuracy.

A supervisory control framework for a diesel powertrain that is capable of utilising predicted look ahead information is developed. The look ahead information as a time trajectory of vehicle speed and load is considered. The supervisory controller considers a discrete control action set over the first segment of the trip ahead. The cost to optimise is defined and pre-computed off-line for a discrete set of operating conditions. A full factorial optimisation carried out off-line is stored on board the vehicle and applied in real time.

In the first approach, a set of predefined trip segments with off-line optimisation is considered. Here a library of segments is considered which would need to provide sufficient coverage of all possible trip characteristics along with a pattern matching or clustering algorithm. Another approach, to use a lumped parameter based model that can characterise the behaviour of the subsystems over the trajectory, is also examined for real-time on-line application. Simulation comparison of both controllers with the baseline controller indicates a 1% total fuel equivalent cost improvement while offering the flexibility to tailor the controller for different cost objective and improving robustness of exhaust emission control.



# Acknowledgements

I am grateful to Volvo Car Corporation and the Volvo industrial Ph.D program for the opportunity to pursue a Ph.D. Sincere thanks to Professor Tomas McKelvey for his guidance and supervision. Thanks to my industrial supervisor Daniel Lundberg for the enlightening discussions and support. Also thanks to Marcus Nilhav for giving me the opportunity to pursue the Ph.D.

Thanks to all my project team members of FFI MultiMEC for bringing on interesting discussions and feedback. I would like to thank all colleagues at Volvo car corporation for their support in my work. Thanks to colleagues at the Electrical Engineering department, Chalmers for their cooperation and kind support.

Thanks to my family and friends for their social support and kindness.

Dhinesh Velmurugan  
Göteborg, October 2018





# List of publications

**Paper 1** Dhinesh Velmurugan, Daniel Lundberg and Tomas McKelvey, "Supervisory controller for a LNT-SCR Diesel Exhaust After-Treatment System", *European Control Conference*, June 2018, Limassol, Cyprus.

**Paper 2** Dhinesh Velmurugan, Tomas McKelvey and Daniel Lundberg, "Supervisory controller for a Light Duty Diesel Engine with an LNT-SCR After-Treatment System", *International Powertrains, Fuels & Lubricants Meeting*, SAE International, September 2018, Heidelberg, Germany.

**Paper 3** Dhinesh Velmurugan, Daniel Lundberg and Tomas McKelvey, "Look Ahead based Supervisory Control of a Light Duty Diesel Engine", *IFAC Conference on Engine and Powertrain Control, Simulation and Modeling (E-COSM'18)*, September 2018, Changchun, China.

## Other relevant publications

In addition to the three papers above, the following paper is also relevant to the topic of this thesis:

Dhinesh Velmurugan, Tomas McKelvey, and Markus Grahn, "Diesel Engine Emission Model Transient Cycle Validation", *IFAC Symposium on Advances in Automotive Control*, June 2016, Kolmården, Sweden.



# Contents

Abstract	i
Acknowledgements	iii
List of publications	v
Contents	vii

## I Introductory Chapters

<b>1 Introduction</b>	<b>1</b>
1.1 Outline . . . . .	1
<b>2 Background</b>	<b>3</b>
2.1 Transport and society . . . . .	3
2.1.1 Energy efficiency and CO <sub>2</sub> legislation . . . . .	4
2.1.2 Environmental impact and NO <sub>x</sub> legislation . . . . .	5
2.2 Diesel engine . . . . .	6
2.2.1 Diesel exhaust after treatment system . . . . .	10
2.2.2 Hybridisation . . . . .	13
2.3 Subsystem complexity in diesel engines . . . . .	14
<b>3 Diesel powertrain control</b>	<b>17</b>
3.1 Propulsion control . . . . .	17
3.2 Engine control . . . . .	17
3.3 Baseline subsystem control . . . . .	18
3.4 State of the art control techniques . . . . .	19
3.5 Supervisory control . . . . .	21
<b>4 Route prediction based control</b>	<b>23</b>
4.1 Route prediction and control . . . . .	24
4.2 Prediction horizon and segmentation . . . . .	24

## CONTENTS

4.3	Driver characterisation and its influence . . . . .	25
4.4	Control implementation . . . . .	26
4.5	Current infrastructure . . . . .	27
<b>5</b>	<b>Contribution and Future work</b>	<b>29</b>
5.1	Contributions . . . . .	29
5.1.1	Problem Statement . . . . .	29
5.1.2	Proposed control architecture . . . . .	30
5.1.3	Supervisory control optimisation . . . . .	31
5.1.4	Potential with Supervisory controller . . . . .	33
5.2	Future work . . . . .	33
5.2.1	Drive cycle characterisation . . . . .	33
5.2.2	Verification of control proposals . . . . .	33
5.2.3	Inclusion of mild hybridisation . . . . .	34
5.3	Summary of Included Papers . . . . .	34
	<b>References</b>	<b>37</b>

# Part I

## Introductory Chapters



# Chapter 1

## Introduction

This thesis is written within the scope of the project titled "Multivariable Methods for energy efficient Engine Control" (MultiMEC). The project partners include Volvo Car Corporation, AB Volvo and Chalmers University of Technology. The project part relevant to this thesis is carried out with cooperation between Volvo Car Corporation and Chalmers University of Technology. This part of the project is financed by Volvo Car Corporation and the Swedish governmental agency for innovation, FFI Vinnova. The aim of the project is to develop a modular control system design for the integrated engine system including combustion engine, emission after treatment and heat management that optimises fuel efficiency with fulfilled emission requirements. The main highlights of the research project and scope is expressed in Figure 1.1.

### 1.1 Outline

The thesis consists of two parts. Part I consists of background, literature survey and advancements in the field of integrated propulsion control followed by a summary of contributions and future work. This part serves as an introduction and motivation for the included papers in Part II.

In Chapter 2, an introduction to the societal impact of combustion engines in passenger cars and legislation development ensuring technology adoption to reduce harmful exhaust gas emissions is described. The incremental increase in technology adoption in diesel engines to fulfil market and legal demands has led to complex sub systems in modern diesel engines. The chapter is concluded with need for holistic control of the diesel engine. In Chapter 3, basics of propulsion control and engine control is introduced. This is followed up with the state of the art control techniques available in the literature that covers supervisory control of diesel engines with the

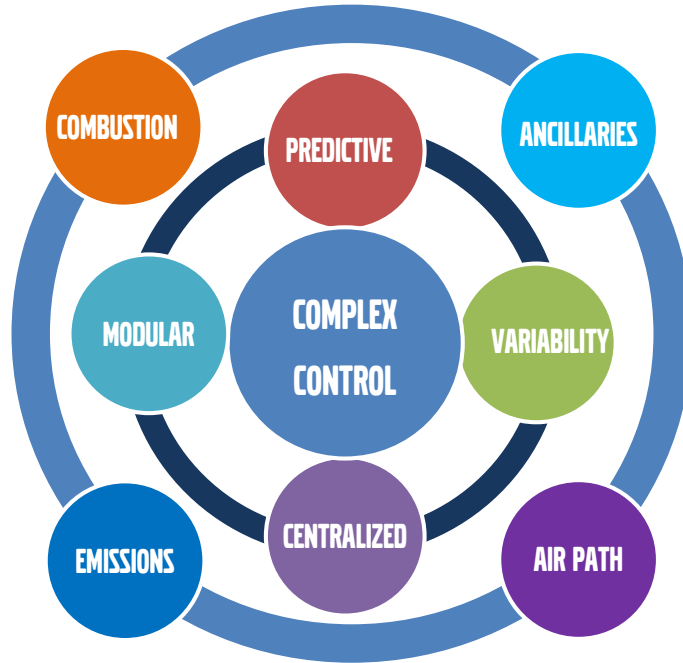

Figure 1.1: MultiMEC Project schematic representation of goals

mentioned complex subsystems. Chapter 4 serves to introduce the area of route and driver - prediction, characterisation and potential impacts. The existing infrastructure and technology needed for look ahead prediction is described. Chapter 5 serves to summarise the contributions of the research activity, a glimpse of future work area and the summary of the included papers.

Part II consists of three scientific papers that constitute the base for this thesis. In [1], a smaller subset of the problem is considered that includes only the  $\text{NO}_x$  after-treatment control. A control interface and a scheme is proposed which is evaluated. In [2], the complexity is increased by the additional consideration of the combustion engine. The carry over and modifications necessary for the supervisory control is discussed, implemented and evaluated. In [3], a model based approach is used to utilise the look ahead information in the supervisory controller. A real time control that uses the look ahead trajectory is described and evaluated.



# Chapter 2

## Background

### 2.1 Transport and society

Transport has greatly influenced civilisation and its development. Today, transport is regarded as a basic necessity and the sector is a significant contributor to global economies. Rapid growth of automobiles has fuelled society's economic prosperity. Passenger cars have grown from a luxury in their days of introduction to a basic necessity. In the moment of disruptive business models of ownership, there is potential for positive contribution to society. Alternate business models provide potential for economically effective use of propulsion technology and environmentally responsible use of resources. Irrespective of the disruptions, passenger car usage has been growing over the past decades and is projected to reach almost a billion as is illustrated with the help of Fig. 2.1.

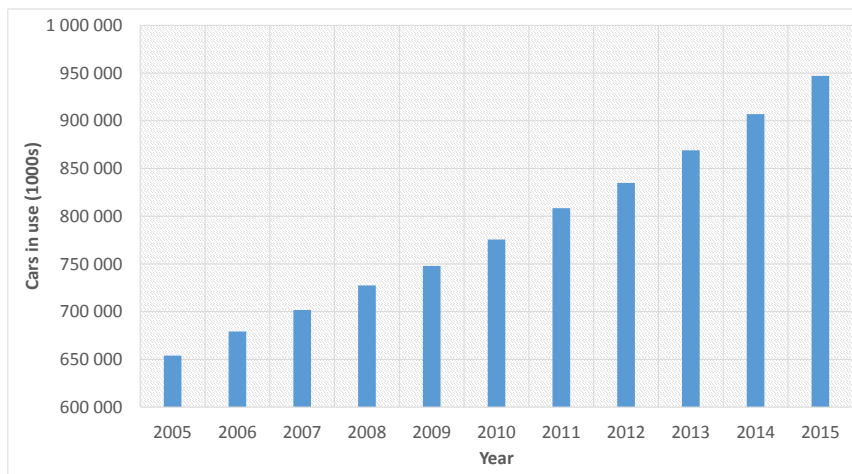

Figure 2.1: Global in use cars.[4]

### 2.1.1 Energy efficiency and CO<sub>2</sub> legislation

Global observations attribute a quarter of the world Green House Gas (GHG) contribution to the transport sector and nearly 12% of the GHG is estimated to be generated from passenger cars as illustrated in Fig. 2.2. [5]. In the EU, transport industry contributed about 21% of CO<sub>2</sub> emissions, 72.9% of which is from road transport, 44.4% of which is from cars. Thus, nearly 6.8% of EU emissions is from passenger cars [6]. In the USA, 28.5% of CO<sub>2</sub> emissions were from transport, 41.6% of which is from passenger cars. Thus making 11.8% of total CO<sub>2</sub> emissions [7]. United Nations Framework Convention on Climate Change (UNFCCC) dealing with greenhouse gas emissions mitigation, adaptation, and finance brought 196 nations come to an agreement (the Paris agreement) to govern emission reductions from 2020. With continuing demand and growth of passenger cars, energy effectiveness is crucial to meet the UNFCCC commitment to limit global warming to 1.5 °C relative to pre industrial levels [8]. To meet the UNFCCC

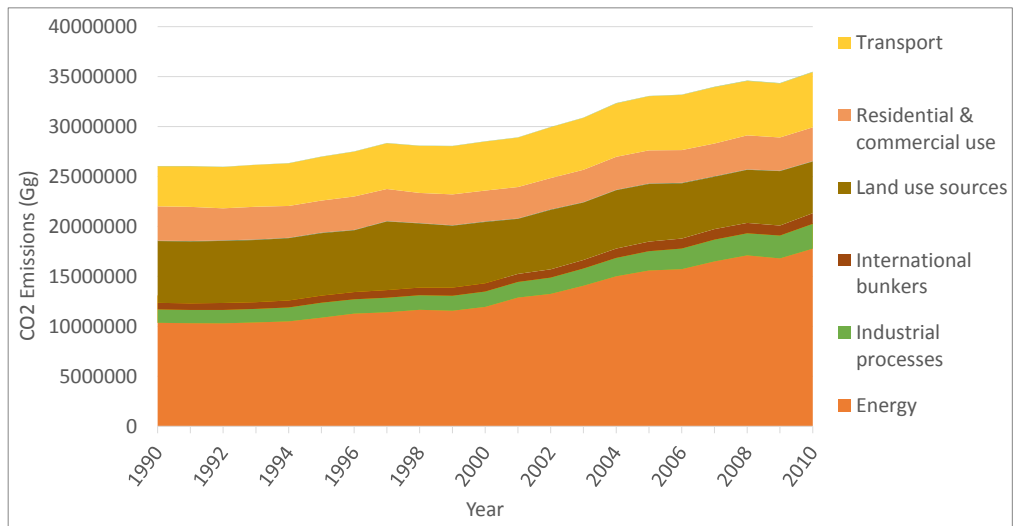

Figure 2.2: Global CO<sub>2</sub> emissions by sector. [9]

commitment, EU GHG reductions in transport sector will have to amount to at least 30% by 2030 compared to 2005. Cars produced 553 Tg of equivalent CO<sub>2</sub> in 2005 and have a target to reduce to 387 Tg by 2030. The number of EU passenger cars in use in 2005 were about 234 million. A polyfit estimate of in use vehicles in 2030 is around 335 million. With an EU average driving distance of 11000 km, the fleet average of cars in use needs to be 105 g/km [10, 11]. The EU legislation is already moving in this direction with 95 g/km being enforced for new registrations in 2021 based

on the NEDC. A further 15% and 30% reduction for 2025 and 2030 is based on the equivalent WLTC target set in 2021. [12–14]

### 2.1.2 Environmental impact and $\text{NO}_x$ legislation

Apart from  $\text{CO}_2$ , exhaust emissions of concern from combustion engine propelled automobiles include carbon monoxide (CO), unburned hydrocarbon (HC), nitrogen oxides (NO and  $\text{NO}_2$ ) and particulate matter (soot remaining after combustion). The environmental impact of diesel exhaust emissions with effects such as smog, acid rain, ozone reaction has been widely accepted across the world [15]. The impact of poor air quality (caused by exhaust emissions) on human health leading to respiratory problems, shortening of life expectancy and degradation of life quality is also recognised by national authorities and health practitioners [16]. The level of  $\text{NO}_x$  emis-

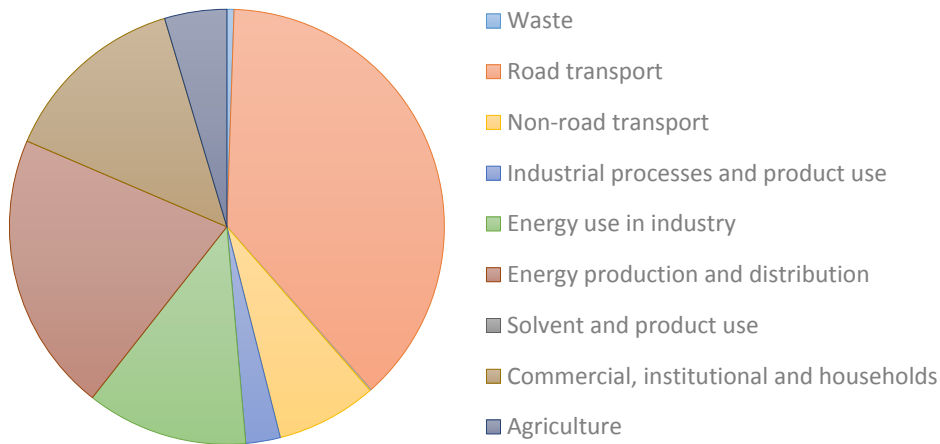

Figure 2.3:  $\text{NO}_x$  generated by sector in the EU

sions have been on a downward trend in the EU (-52% since 1990) and US, and have been on the rise in growing economies especially in China and India. In the EU, road transport sector is the leading contributor to anthropogenic  $\text{NO}_x$  formation at about 40% followed closely by the energy sector as is shown in Fig. 2.3 [17]. In recognition of this and to substantiate control of such harmful engine exhaust emissions, national bodies have set forth exhaust emission test procedures to be certified for sales of automobiles. Regulatory bodies for monitoring, control and certification of vehicles have designed increasingly stringent test procedures since 1980. Deviations from legislative intentions and reality have been highly alarming. Effective

reduction in pollutant emissions is expected to align with real driving conditions starting with Euro 6d temp mainly with the use of Real Driving Emissions (RDE) test procedure [18, 19]. The usage of Portable Emission Measurement Systems (PEMS) device to measure on road emissions along a route distributed in almost equal proportions of urban, rural and motorway traffic combined with extended ambient conditions is a key change brought in by RDE introduction. The use of World Light Transient Cycle (WLTC) and RDE in conjunction with evaluation methodologies (CLEAR and EMROAD) and Relative positive acceleration (RPA) aim to enforce strict emission constraints at all instance of vehicle operation. An overview of the significant changes adopted in the emission certification procedure is shown in Fig. 2.4. Technology for meeting levels beyond legal requirements exist already [20]. RDE test results reported publicly as mandated under the EU regulation indicates that the technology for fulfilling the stringent RDE and PEMS procedures exist and are already available on the market [21].

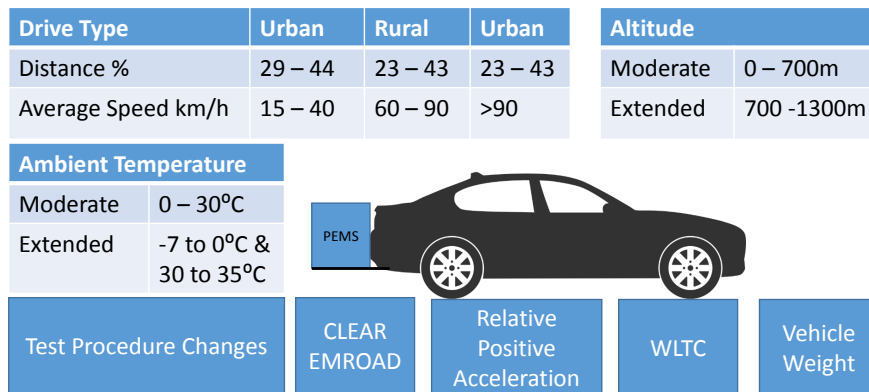

Figure 2.4: A brief overview of the boundary conditions in Real Drive Emissions test procedure

## 2.2 Diesel engine

Modern day passenger cars are propelled by combustion engines, electric machines or a combination. Combustion engines have been the dominating choice in road transport for the past century since their invention. Diesel engine powered cars have been popular for the last few decades due to their higher energy efficiency compared to gasoline engines. In the EU, the passenger car market has an almost equal share of both gasoline and diesel powered engines. Development of diesel engine technology for energy efficiency has been driven by legislation and customer demands. Advancements

in diesel engine emission technologies has progressed due to legislation, media, customer awareness and manufacturer's social responsibility.

The Diesel cycle comprises of 4 strokes as shown in Fig. 2.5. Fresh air is drawn in to the engine cylinder during the intake stroke when the intake valve is open. The fresh air drawn is compressed which increases the temperature in the engine cylinder during the compression stroke. Diesel is injected into the cylinder which causes combustion by self ignition and delivers work at the piston in the power stroke. The residual gases are removed by opening the exhaust valve. Modern diesel engines are direct injected, usually turbocharged and with advanced catalysts for exhaust after-treatment [22].

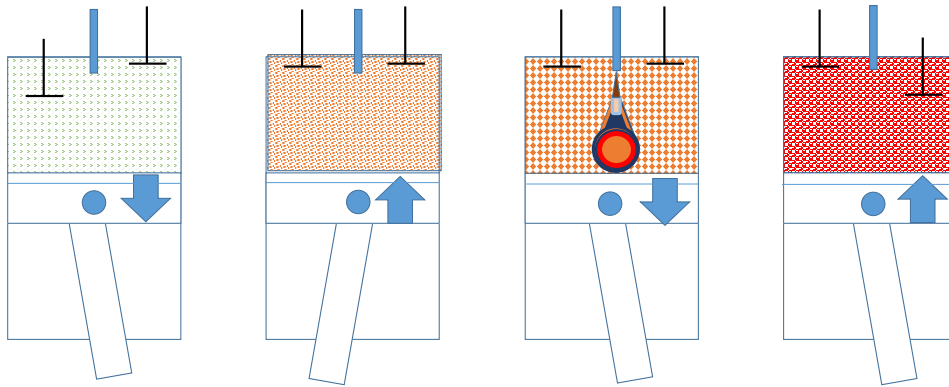

Figure 2.5: The Diesel cycle shown with the four strokes from left to right: Intake, Compression, Combustion and Exhaust stroke

### Common rail direct injection

Diesel engine noise primarily due to diesel combustion has been a long impediment in their adaptation to passenger car applications. Indirect injection systems did not improve the noise issue significantly enough. The fuel efficiency advantage offered by diesel engines compared to gasoline engines was not sufficient for significant offtake in the passenger car segment. The introduction of common rail direct injection systems with split injection strategies significantly improved the noise generated by diesel engines while offering increased energy efficiency due to accurate fuel control. The system comprises of a high pressure pump that accumulates pressurised fuel in a fuel rail. The high accuracy electrically actuated fuel injectors used in

conjunction with the common rail offer greater degree of freedom to inject a wide range of fuel quantity accurately at precise timing. A schematic of the components is shown in Fig. 2.6. These systems provide for better  $\text{NO}_x$  and soot trade-off in comparison to legacy mechanical systems due to such accurate fuel control and at very high pressure. It also provides for increasing the exhaust temperatures to quicken the light off of the catalysts downstream the diesel engine in a fuel efficient manner [23].

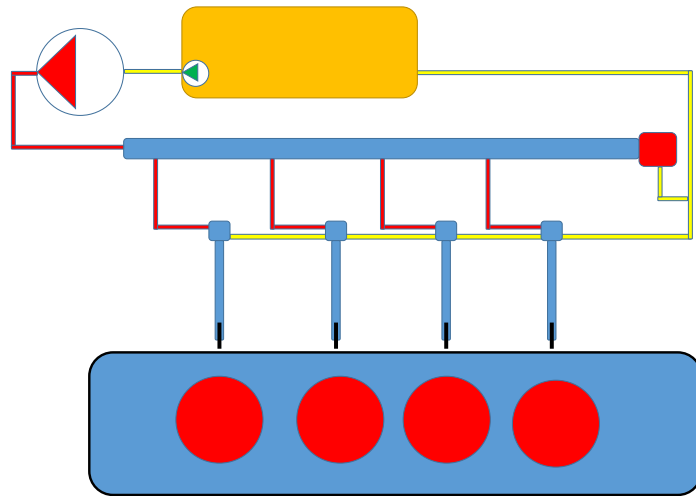

Figure 2.6: Common rail direct injection system shown with its main components: Low pressure fuel pump in diesel tank, High pressure pump, the accumulating common rail, electrically actuated fuel injectors in the cylinder head and the fuel return lines.

### Turbocharged diesel engines

The diesel engine is lean burn since diesel fuel is burnt with air in a ratio that usually exceeds the stoichiometric air-diesel fuel ratio (14.5 : 1) usually by factors in the range of 2-5. As the air-fuel ratio decreases, the engine generates more soot and also is less energy efficient due to the poor combustion of fuel. Thus the amount of fuel that can be injected is limited by the amount of fresh air in the cylinder. It is natural here to consider that more fuel injected leads to more power produced. In order to increase the power of the engine and improve energy efficiency, modern diesel engines are equipped with turbochargers. A turbine placed in the exhaust is rotated by the exhaust energy which drives the compressor that is mechanically linked to the turbine. The compressor placed in the intake air system increases the

pressure of air which is drawn into the cylinder thereby increasing the engine power. The increased efficiency is a result of using the exhaust energy to increase the volumetric efficiency of the engine. While it increases efficiency and power, the response time of the engine is lowered due to the inertia of the turbine and the associated mechanical systems [22]. A schematic of a turbocharged diesel engine with associated components is shown in Fig. 2.7.

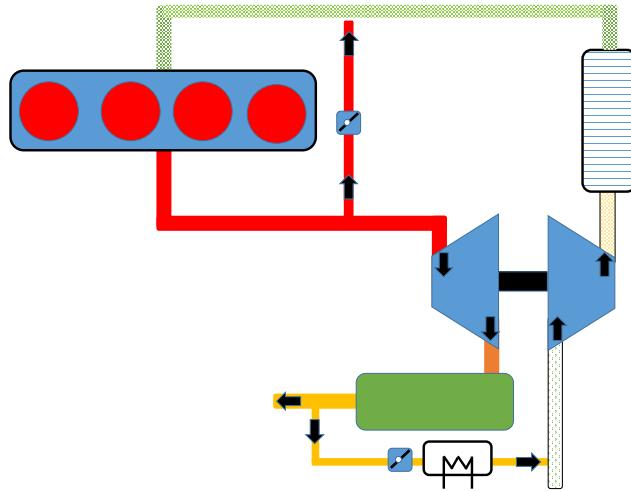

Figure 2.7: Turbocharger and Exhaust gas recirculation in a Diesel engine

### Exhaust gas recirculation

In order to reduce the  $\text{NO}_x$  generated by diesel engines, Exhaust Gas Recirculation (EGR) technology is widely adapted by diesel engine manufacturers as an in-cylinder measure. A fraction of the exhaust gases is diverted back to cylinder during the compression stroke of the diesel engine. The recirculated gas could be cooled to further improve the effectiveness of the EGR to reduce  $\text{NO}_x$ . The exhaust gas acts as an inert species in the combustion chamber to reduce the combustion temperature thereby reducing the generation of  $\text{NO}_x$ . This however leads to a reduction in energy efficiency since it effectively reduces the air available for combustion. It also increases the soot due to lower combustion temperature. Modern day diesel engines could employ low pressure (derived after turbine expansion), high pressure (derived before the turbine expansion), cooled (passing the exhaust air through a cooler) or warm (without any cooler) EGR systems or a combination of these mentioned. EGR is controlled by an EGR valve that is driven with

reference for actuation from the engine control unit [24]. A high pressure warm EGR system is shown in Fig. 2.7.

### 2.2.1 Diesel exhaust after treatment system

Car manufacturers have equipped diesel engines with Exhaust After Treatment Systems (EATS) to meet stringent emission legislation which has been tightened continuously over the last decade. The prime exhaust species that are controlled include nitrogen oxides ( $\text{NO}_x$ ), soot particulates, unburned hydrocarbon species (HC) and carbon monoxide (CO). Unlike the Three Way Catalyst (TWC) that is able to control these emissions (excluding soot) in the gasoline engine, the TWC is not effective in diesel applications since diesel engines are operated in fuel lean conditions and hence the exhaust tends to contain significant amount of oxygen (which is essential for the simultaneous redox reactions among the exhaust species). Thus specially developed systems are used separately for reduction of  $\text{NO}_x$ , capture and oxidation of soot and oxidation of HC and CO [25]. The EATS system of a Euro 6 diesel engine used in our work is shown in Fig. 2.8.

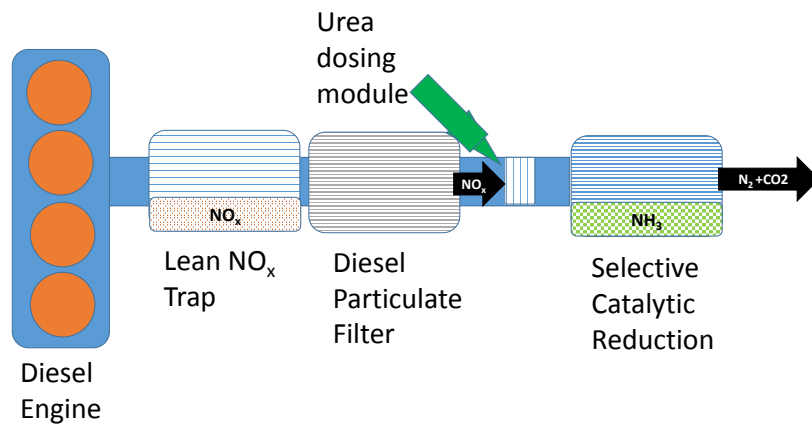

Figure 2.8: Exhaust After treatment System for a Euro 6 Diesel Engine

#### Diesel oxidation catalyst

The Diesel Oxidation Catalyst (DOC) contains precious metals and the objective with the catalyst is to oxidise the HC and CO species in the diesel exhaust. Upon lightoff which is usually around  $100^\circ\text{C}$ , the catalyst is



almost 90% efficient. The catalyst along with the Diesel Particulate Filter (DPF) oxidises nitrogen monoxide to nitrogen dioxide. This is useful for the Selective catalytic Reduction (SCR) catalyst to attain increased  $\text{NO}_x$  conversion efficiency [26]. The functionality of the DOC is summarised in Fig. 2.9.

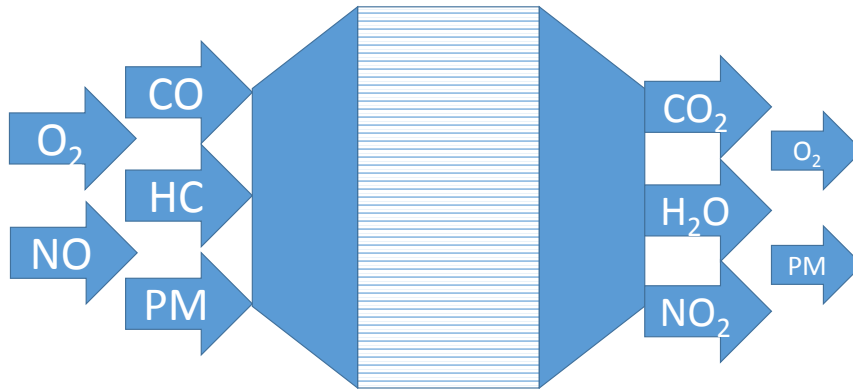

Figure 2.9: Schematic summarising the functionality of the diesel oxidation catalyst

### Diesel particulate filter

The DPF captures and traps the soot particulates in the diesel exhaust. A simple visualisation of the mechanism is shown in Fig. 2.10. The trapped particles are burnt with the help of passive regeneration by oxidising soot using nitrogen dioxide or by active regeneration. Active regeneration is achieved by increasing the exhaust temperature by using split post injections in the combustion engine or by using a fuel injector in the exhaust pipe. The DPF is usually catalysed to increase the nitrogen dioxide that enables burning soot economically, treating unburnt HC and also for improving SCR efficiency by having a higher  $\text{NO}_2 : \text{NO}_x$  ratio in the treated gases. [27]

### Lean $\text{NO}_x$ trap

A Lean  $\text{NO}_x$  Trap (LNT) operates by adsorbing the  $\text{NO}_x$  species as nitrates in the catalyst. The amount of adsorption is limited by the catalyst volume and the catalyst temperature. The adsorbed nitrates are reduced in a fuel rich environment by operating the diesel engine fuel rich for short time instances. An illustration of the main mechanism is shown in Fig. 2.11. The LNT is not efficient at high loads and high exhaust temperatures. But

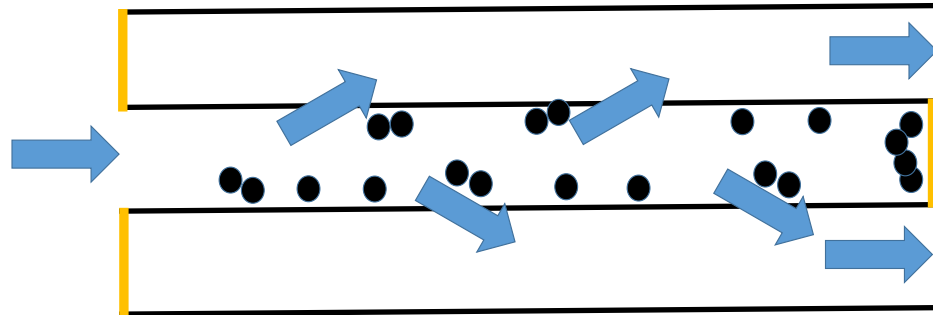

Figure 2.10: Illustration of simplified mechanism of soot accumulation in a diesel particulate filter

the LNT systems are capable of treating  $\text{NO}_x$  at a lower light-off temperature compared to SCR catalyst. The LNT system imposes a higher fuel consumption due to the regeneration events when the catalyst reaches a certain  $\text{NO}_x$  threshold. Also, operating the diesel engine in fuel rich conditions poses drivability issues and hence need to be limited to certain driving conditions. [28]

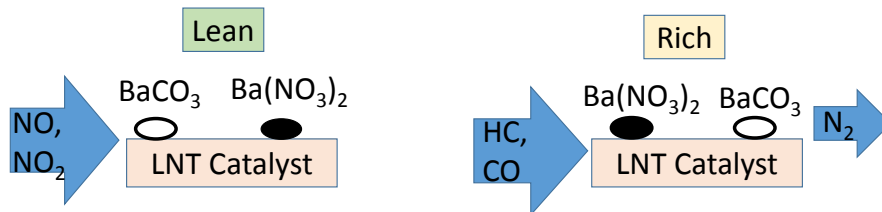

Figure 2.11: Simplified mechanism of lean  $\text{NO}_x$  trap shown during  $\text{NO}_x$  adsorption under fuel lean conditions (left) and  $\text{NO}_x$  reduction under fuel rich conditions (right).

### Selective catalytic reduction

Most heavy duty diesel engines used in trucks, construction equipments and stationary equipments use SCR technology to treat  $\text{NO}_x$ . This is highly suitable for applications where the exhaust temperatures are higher due to their relative higher load in their applications. Ammonia is used as the  $\text{NO}_x$  reducing agent. This is generated by injecting aqueous urea solution in the

exhaust pipe before the SCR, when the thermal conditions are satisfactory for urea decomposition to ammonia. The ammonia generated reduces  $\text{NO}_x$  in the exhaust in the SCR. Excess ammonia is stored on the SCR, the capacity of which is dictated mainly by the catalyst temperature. The SCR catalyst functioning along with the associated dosing system is shown in Fig. 2.12. The SCR  $\text{NO}_x$  conversion is almost negligible until the SCR light off has been reached, which is higher than the LNT light off temperature. The poor performance in low temperature conditions sets the requirement for heating up the catalyst using the engine exhaust thereby increasing fuel consumption. [29]

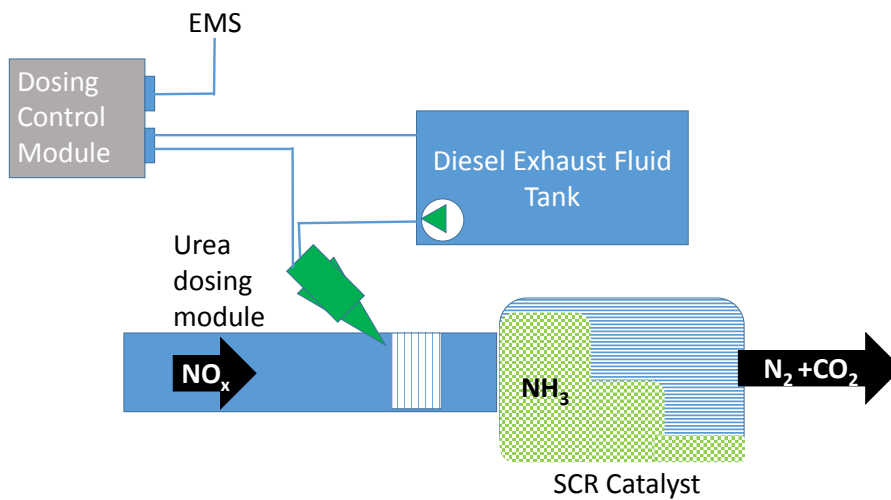

Figure 2.12: Selective catalytic reduction with associated diesel exhaust fluid dosing system

### 2.2.2 Hybridisation

In vehicles powered with more than a single source of propulsion power, torque split needs to be determined to satisfy the driver request. Depending on the comparative size of the devices, the strategies vary extensively. If the two sources have almost equal power, they could be classified as full hybrids. If the electrical machine provides assistance to the combustion engine propulsion, these can be categorised as mild hybrids. Electrification of cars is hindered mainly by cost. Minor hindrance to their market penetration include range anxiety, battery power density, charging infrastructure etc.,. Fig. 2.13 is indicative of the energy efficiency potential of electrification compared with relative cost of technology upgrade.

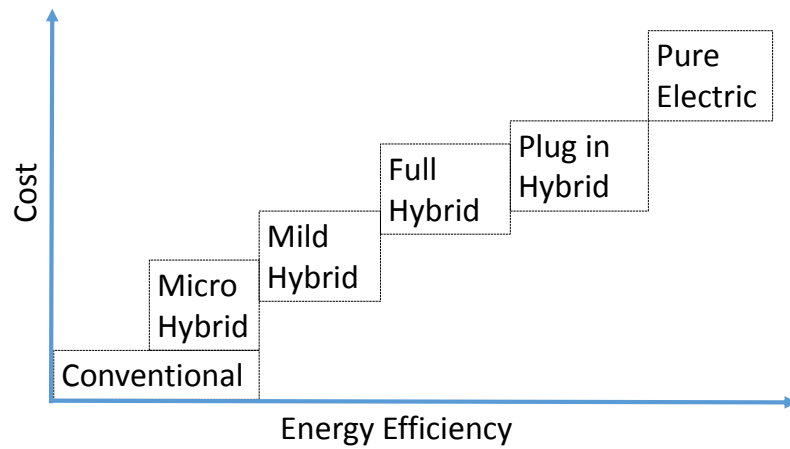

Figure 2.13: The impact of hybridisation on cost and energy efficiency

Mild hybrids could be utilised to reduce the effect of transient power demands on the combustion engine thus reducing exhaust emissions and fuel consumption. They could be used to alter engine loads so as to operate the combustion engine more fuel efficiently even as driver demand is different. Popularly five different locations (P0 to P4) of the electric machine on the drivetrain are examined by automotive experts as shown in Fig. 2.14. These pose different performance capabilities along with associated cost, robustness and packaging complexity. Strategies for torque split need to account for possible brake energy recuperation, transient dynamics, driving range among several others for optimal energy utilisation. Being a cost efficient technology to fulfil CO<sub>2</sub> and emission requirements, mild hybrids are expected to be a popular choice among automotive manufacturers.

## 2.3 Subsystem complexity in diesel engines

There has been an incremental change in emission control legislation over the years. Manufacturers have adapted combustion engines by adding subsystems to stay in line with the requirements. This has meant that system complexity has been on an escalating growth. To meet growing legal exhaust emission regulation and consumer performance improvement demands, diesel powertrains use an array of complex subsystems.

In modern diesel engines, an array of technology is used to control NO<sub>x</sub> exhaust emissions. These include engine in-cylinder measures such as ex-

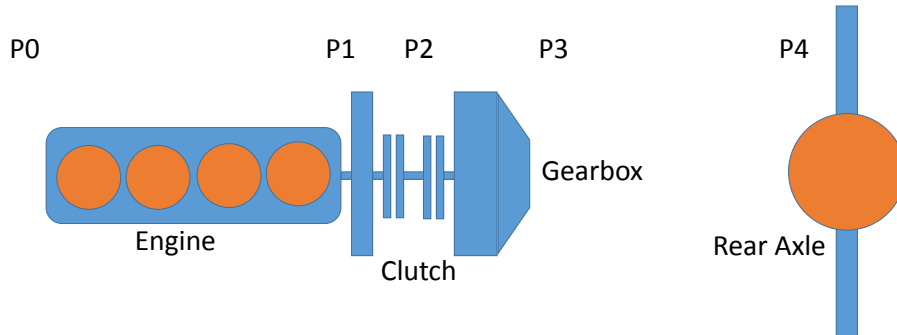

Figure 2.14: Mild Hybrid: Possible configurations / positions for electric machine placement

haust gas recirculation, fuel injection, valve open and close timing, engine swirl etc.,. External engine measures include the EATS components such as the LNT and SCR. Subsystems might affect both emission control objectives and fuel consumption. Incremental emission legislation has led to addition of subsystems. Fig. 2.15 is a brief of technology adaptation by manufacturers to meet legal demands.

Presence of varied actuator mechanisms in the subsystems impacts their response time. Combustion systems controlled by fuel injection systems contain piezoelectric actuators that can be actuated precisely with response time in the order of micro seconds. Fuel injection systems have a combined response time that is in the order of milli seconds. This is mainly because fuel is supplied by the on board tank and fluid control is thus assured [30]. Air path related systems such as exhaust gas recirculation and turbocharger systems depend on turbine mass inertia, limited by compressor speeds, the actuator valves, engine speed-load and also by the air dynamics. The complex air path circuit that includes cooling circuits and compression or expansion paths make the response time slower in comparison to the combustion systems. The response time of such systems are thus slower and in the order of 1 to 3 seconds [31].

In case of Lean  $\text{NO}_x$  trap, the adsorption of  $\text{NO}_x$  on the catalyst is complex and dependant on the  $\text{NO}_x$  coverage fraction and catalyst temperature. The regeneration of LNT catalyst is controlled both by fuel injection as well as air path actuators. The additional impact of LNT regeneration on torque

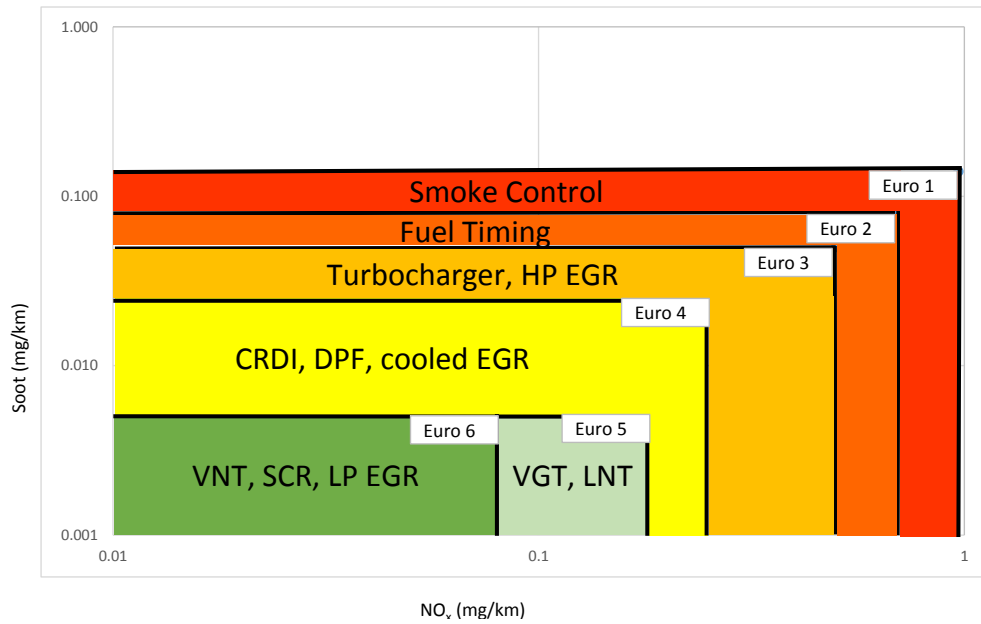

Figure 2.15: Incremental emission standards with corresponding diesel technology adopted popularly to fulfil

delivery makes the LNT system regeneration response slower than the air path system around 5 to 15 seconds. The SCR system depends on  $\text{NH}_3$  storage on the catalyst and the  $\text{NO}_x$  conversion efficiency depends on the exhaust flow, temperature and the  $\text{NH}_3$  coverage fraction. The response time of SCR systems depend on urea delivery and sufficient conditions for dosing thus having a response time in the order of 30 seconds.

These subsystems vary in their implementation due to their response times, dependency on driving cycle, EATS catalyst and engine states. With incremental addition of subsystems constrained by low computational powered control systems, rule based coordination has been the main stream control implementation due to experience and rich experimental data with these systems. Coordination of subsystems were not extremely difficult when the number of subsystems were low and they were relatively simple. Mechanical control systems and later PID controls were sufficient for earlier propulsion systems. But current generation systems use a variety of subsystems that have a common goal and are dependent on one another. The use of slave-master type of systems loose the potential synergy offered by the subsystem interactions. With the introduction of Euro 6d temp, several subsystems would need a tighter coordination to fulfil legislation effectively while being efficient.

# Chapter 3

## Diesel powertrain control

The driver in a passenger car sets a reference speed request that is processed by the vehicle control unit. The Engine Control Unit (ECU) delivers the demanded power by the vehicle control by coordinating subsystem controllers to fulfil legal requirements. The coordination could use a holistic objective to take advantage of the subsystem synergies.

### 3.1 Propulsion control

The driver reference for vehicle speed is obtained from the accelerator pedal or from the cruise controller. The vehicle control module determines the requested torque and engine speed through the help of pedal maps and a road load model with vehicle parameters. For a vehicle with automatic transmission, the transmission control unit determines the suitable gear for the driver request. Thus it decides the engine speed and torque. In hybrid vehicles, a controller is also needed to split the torque between the different propulsion power sources. The power request translated from driver request by the vehicle control module is summarised in Fig 3.1.

### 3.2 Engine control

Modern diesel engines include a multitude of complex electrical and electronic actuators and sensors as shown in Fig. 3.2. These are essential for operating the various engine subsystems. The sensors and actuators are connected to the engine control unit. The Engine Control Unit (ECU) is further connected to other sub units in the vehicle through an array of communication protocols. The ECU could thus communicate with any possible external information such as Look ahead information provided by a telematics system. The engine control unit computes the actuator actions based on

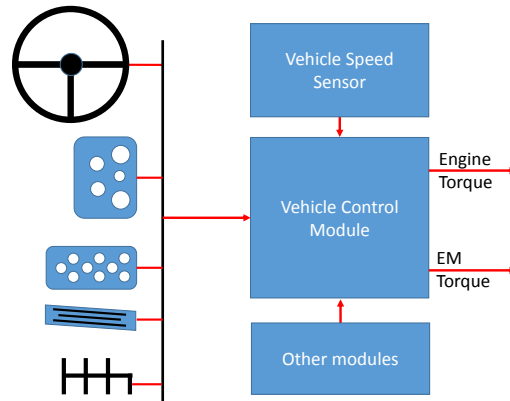

Figure 3.1: Vehicle control module shown with inputs from driver and vehicle speed sensors to determine the power required from the propulsion sources on board.

sensor information and calibration of the engine control software. Automotive grade ECU's are made to withstand a wide range of climatic conditions. In making the electronic components robust, the ECUs are expensive and offer limited computational ability compared to general electronics. Being a core automotive component, control strategies developed for engine systems tend to be robust. In developing such strategies, actuator control is achieved with the help of look up tables, parameters and switching models that are computationally less intensive. [32]

### 3.3 Baseline subsystem control

The ECU is supplied with a targeted engine speed and torque requested from the vehicle control. The desired power is delivered through the coordination of the engine subsystems to fulfil the demand while satisfying emission regulations. The engine subsystems are usually operated with settings that have been calibrated on the ECU based on the current engine speed and torque required. The ECU utilises the sensors and models of the systems developed to generate these actuator settings. In early generation engines, fewer and simpler subsystems meant that they could be calibrated with experience from expected behaviour and testing. The complexity started to mount with the use of turbochargers which improved efficiency and power



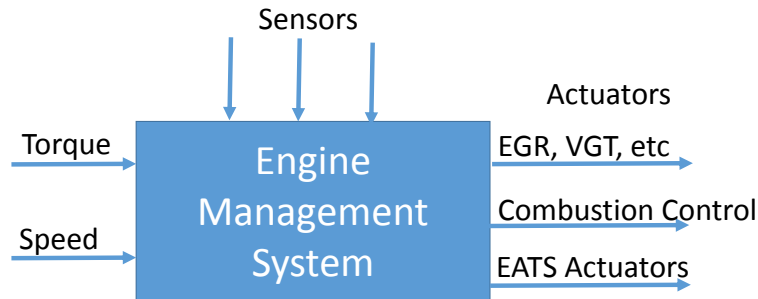

Figure 3.2: Engine management system assisted by sensors fulfils reference torque and speed requirement by controlling the engine subsystem actuators.

but at the cost of response time. Since then there has been a substantial focus on improving the performance with advanced control techniques. The addition of more subsystems that have been complex such as the aftertreatment system pose new challenges. The degrees of freedom offered with the array of systems on the modern diesel engine provide for operating the engine in diverse manners depending on the objective. Conventional subsystem coordination has primarily been rule based since the complexity growth has been incremental. Thus experience in these systems has been used to coordinate the subsystems so far.

### 3.4 State of the art control techniques

As mentioned in 2.3, the incremental growth of engine subsystems followed the emission legislation requirements. In simpler subsystem set-up, coordination between subsystems was more rule based. This was acceptable due to the simplicity of subsystems. However with increased subsystems, the interdependence of subsystems with the same and conflicting objectives, the need for more integral subsystem coordination is has become necessary.

Turbocharged diesel engine control using mean value models has been a popular approach [33]. Feedforward controls based on mean value models is a widely applied industry approach. Feedback based control approaches using

mean value models has also been used for turbocharged diesel engines with EGR [34–36] and layered or cascaded control approaches. Model predictive controllers have also been proposed in studies [37] with inherent limitations of computational capacity limiting their implementation.

Studies with EGR-SCR balancing along with fuel consumption minimisation have been carried out that have shown potential fuel savings [38]. A control oriented model for integrated engine control has been studied in [39]. An equivalent cost based integrated diesel engine control approach is studied in [40, 41] where equivalent costs have been proposed for total fuel consumption minimisation under emission constraints.

Model Predictive Control (MPC) has been used significantly especially in subsystems. MPC for torque split, Air path control, EATS control have been carried out. However an approach for the complete system has been deemed too complex for the ECU. An MPC implementation is mainly hindered by the absence of algorithms that are capable of execution in the limited memory framework in the EMS. However research in this area is growing and a breakthrough in either hardware or algorithms can make a bigger acceptance to their implementation. [42]. The use of data based methods has prevailed in engine control strategies that minimise the computational requirements. Data driven adaptations have been proposed by few. However, the Engine control system robustness requirements are not met with the proposed solutions in a cost efficient manner. Further the ability to model the subsystems with calibration experience with the subsystems has led to a good accuracy resulting in incremental performance improvements with traditional data based methods.

Hybrid electric vehicle control where optimal power split of propulsion power source is the main objective has shown similar control techniques. A variety of available control techniques for hybrid vehicle control has been shown in [43–49]. Optimal control techniques have been mainly studied and suggest that heuristic based systems for online implementation could be derived from a mix of targeted drive cycles. A summary of control techniques in propulsion control as discussed above is summarised in Fig 3.3.

In the area of supervisory control methods for complex powertrain systems, the literature is rich in optimal control but poor in real time control techniques. Significant amount of studies have focussed on optimal control of systems which serve as a benchmark for real time controllers. Also, focus has been mostly on heavy duty diesel engines and applications.

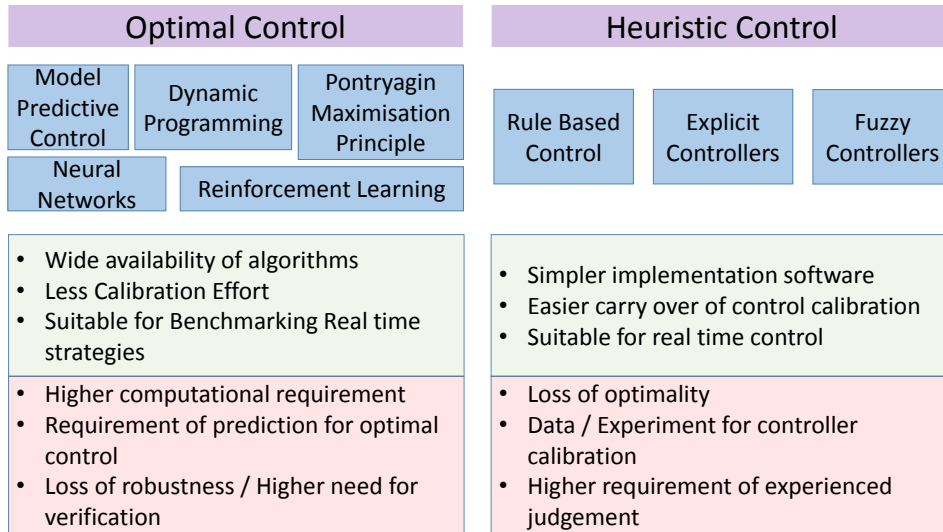

Figure 3.3: Comparison of optimal and heuristic control techniques for supervisory control of powertrain systems

## 3.5 Supervisory control

In our research, a supervisory controller that takes a holistic perspective of the engine and its subsystems is intended to be developed. The proposed controller is also aimed to be implementable in a real time ECU. An equivalent consumption management approach is chosen so that controller performance could be judged based on a fair metric. An Equivalent Consumption Management Strategy (ECMS) is used with quantification of cost of actions in fuel equivalent terms [50].

To propose a suitable framework for the coordination of subsystems, a system analysis of the subsystems is carried out on the Volvo Euro6d diesel engine. The division into subsystems is done such that the powertrain is broken down into significant functional blocks. Each subsystem has a prime objective and can affect other subsystems as indicated in Fig 3.4. As an example, EGR, SCR and LNT systems have the main objective to reduce  $\text{NO}_x$  emissions. Fuel injection timing can be used to control  $\text{NO}_x$  emissions too. But this would also increase fuel consumption. A knowledge based controller that has information of how much  $\text{NO}_x$  can be treated by the EGR, LNT and the SCR could be used to such that fuel consumption can be minimised while also controlling  $\text{NO}_x$  emissions.

The hypothesis is that control of such complex subsystems would help in developing a robust controller that can guarantee better fuel consumption and controlled exhaust emissions compared to a master-slave interaction

between the subsystems described in 3.3.

In order to control the subsystems, the main phenomenon of these subsystems are studied. The idea is to use the phenomenon to develop control strategies from a holistic perspective. The hypothesis is that such a controller would be superior in performance to the baseline rule based controller for subsystems. In doing so, 8 subsystems are listed:

1. Boosting system including the air filter, turbocharger, cooler
2. Combustion including the fuel injection system along with the cylinders and manifolds
3. High pressure EGR including the EGR valves and the cooling system
4. Low pressure EGR including the EGR valves and the cooling system
5. The Kinetic Energy Recovery System (KERS) based on an belt driven integrated starter generator
6. Lean  $\text{NO}_x$  trap including the associated sensors
7. Diesel particulate filter including the associated sensors
8. Selective catalytic reduction catalyst and urea dosing system

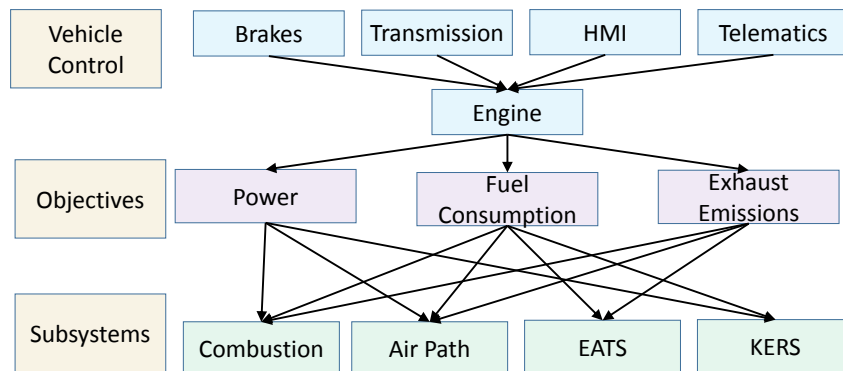

Figure 3.4: Subsystems in a diesel engine and associated complexity in control for objective fulfilment

# Chapter 4

## Route prediction based control

With the growth of positioning system in car navigation systems and general acceptance of mobile devices, route prediction is a certainty in the near future. Advances in autonomous vehicles have made significant contributions in development of hardware and infrastructure for route prediction. Continued market penetration of devices proves the acceptability of such systems [51, 52]. Predicting vehicle speed and road load is significant for power-train control and optimisation. Driver behaviour is an important factor that can improve accuracy of this look ahead information. Implementation of prediction based controllers for route based control have varying degree of computational requirement depending on being online, offline or cloud based strategy. An overview of systems required for route prediction based control is shown in the info-graphic in Fig. 4.1.

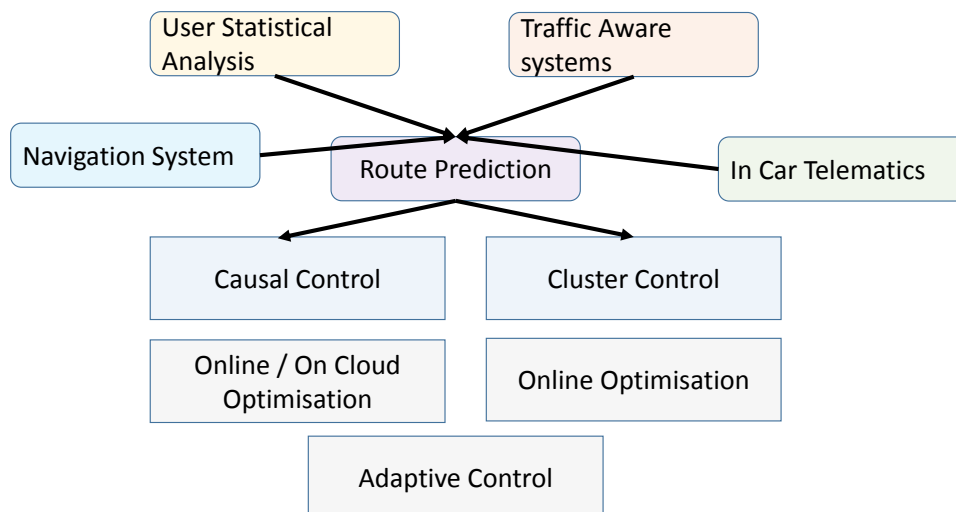

Figure 4.1: Route prediction and associated control techniques

## 4.1 Route prediction and control

Optimal route or trajectory prediction based on real time traffic and statistical analysis is already available as a service. Foremost, the route optimisation is carried out with minimal time to destination in parallel with minimum tolls and minimal distance. In a study with 252 drivers in Washington and Seattle to predict route from trip observations, it was noticed that on average 40% of trips taken were repeated trips [53]. This opens up the possibility to predict a vehicle trajectory given a history of routes. With information on the existing position and historic logs of the user travel, the destination and the entire route can be predicted to an accuracy of about 90% after 2-3 minutes or kilometres driving from the initial position. Route characteristics such as traffic flow, road grade, wind speed also affect fuel consumption and emissions. [54, 55].

The potential benefits of using predicted driving route has been demonstrated in [56]. Optimal control performance can be viewed upon as the performance for the specific controller with a 100% certainty of route prediction to realisation. Of course, in reality this will be impossible and deviations from prediction need to be accounted for in a practical implementation. However, the results achieved with optimal control can be viewed as a benchmark for comparison of performance.

## 4.2 Prediction horizon and segmentation

Destination of the route travelled is prone to errors in route prediction with a higher probability in comparison to near future predictions in short horizon. Traffic conditions are also volatile. The confidence of prediction thus is high for short immediate horizons. Thus segmentation of available look ahead information and powertrain control in short near future horizon could lead to reliable performance.

Subsystems such as the EATS have a longer response time in comparison to fuel injection. With an integrated approach, the combined system performance could be improved if the controller could take advantage of the synergy while considering the subsystem differences. Such holistic systems would need to consider the spread in response times, functional overlap and interference of the subsystems. A lot of research has been done with open loop control. Most have the full drive cycle as horizon and optimise over the entire drive cycle. These solutions offer benchmark for optimal performance but not real time implementation. However, these could be applied to shorter horizons but there is a need to carefully handle the horizons. There is risk of losing generality and becoming worse than rule based

systems in some cases.

Another approach to utilise the predicted route is to categorise parts of the driving route to segments. In this approach, a dictionary of pre categorised segments is available. Each segment categorised has a varying characteristic that could be parametrised, e.g. in average vehicle speed, acceleration, distance, location, driver behaviour or a regressive combination. An optimal control could be parametrised by these dictionary segments. Clustering of similar driving segments is made from the predicted route and the corresponding controller is applied to the segmented identified. An example of clustering could be [57]. This method however depends on the segment identification, sufficient coverage of scenarios and correlation of identified segments. This could lead to sub optimal performance and in some cases there could be worse performance than rule based real-time controllers.

### 4.3 Driver characterisation and its influence

Driving profile, including characteristics of acceleration, braking, distance travelled play an important role in the behaviour of powertrain systems. These characteristics have been acknowledged to impact energy efficiency and emission control also by legislation in using Relative Positive Acceleration (RPA) for representative real drive cycles [58]. In a study on driving style, fuel consumption increased by 20-40% while  $\text{NO}_x$  was increased by 50-255% with higher RPA [59]. The influence of eco-driving on fuel consumption is also well established to the extent that transportation authorities emphasise knowledge and practice of such behaviour. Also significant is societal aspects of mobility. Regional and cultural influence on driving behaviour has indicated variations and similarities as identified in a survey [60]. Their impacts have been studied by researchers of fuel economy impact. Knowledge of driver behaviour offers a potential to increase energy efficiency and control exhaust emissions. Driver adaptive systems might be key to unleash the potential of look ahead systems. Deviation from prediction of drive cycles can be minimised using such driver characterisation. Use of drive behaviour models in combination with traffic flow information offers potential for powertrain control optimisation.

Other aspects of driver behaviour other than aggressiveness also exist. These could be frequency of operation, average distance travelled, maintenance of equipment, loading characteristics. These play significant role in ageing prediction, a key parameter that affects different components of the propulsion system differently. A summary of these influencing factors is shown in Fig. 4.2.

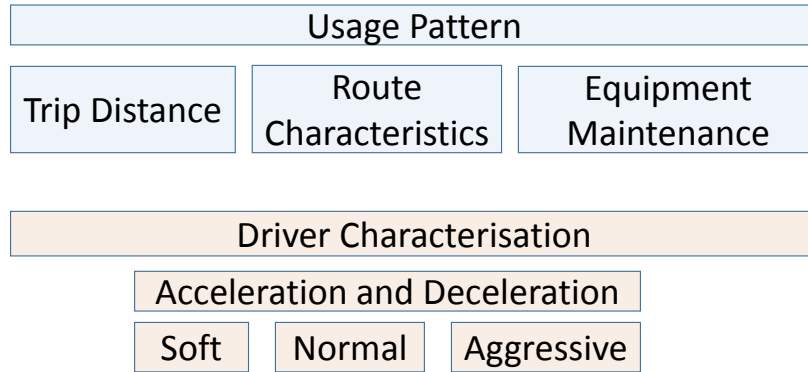

Figure 4.2: Driver behaviour and vehicle usage pattern that influence fuel consumption and exhaust emissions

## 4.4 Control implementation

With incremental growth in the number of electrical and smart sensors on board the engine, there is a consistent growth in memory requirements on the ECU. The automotive functional safety standard, ISO26262 applicable throughout the lifecycle leads to higher requirement of memory and functionality including powertrain control. Along with increasing legislation demands on diagnostics, there is a huge proportion of on board diagnostic functions that consume memory. Control functions for torque and fuel delivery that are scheduled with higher frequency also consume a lot of RAM [61]. There is potentially a limited amount of memory for introducing advanced control concepts unless automotive specific algorithms are developed.

Online control where models, solvers and the control are implemented on board the EMS, while being robust is usually limited by computational capacity onboard the vehicle. Online optimisation techniques rely on the hardware where all computation is carried out. Since they are limited by memory, only less memory demanding control such as rule based techniques or offline-optimised control can be used.

The potential to use advanced controls might increase with distributed or integrated control units but that would place additional constraints on the other systems and robustness cannot be guaranteed [62]. Over the air updates might help in bringing more efficient algorithms when available but flexibility is usually limited by the hardware. It is further complicated



by the product development cycle in the automotive industry where these designs need to be frozen quite early in the process.

An Alternate is to use cloud services. But this would rely on cloud computing resources and quality of connectivity. Cloud computing might be able to offer computational requirements for Model Predictive Control (MPC) and Dynamic Programming (DP) solutions to be implemented. These systems could be much flexible compared to on board solutions as they could offer change of infrastructure with advances in computing technology. But open questions on communication, cybersecurity and economy exist. The use of such cloud systems could be potentially used for non Automotive Safety Integrity Level (ASIL) classed functionality and control. However, there are potential pitfalls with the capability to demonstrate emission legislation if such functions would impact exhaust emissions. An overview of implementation structures possible is shown in Fig. 4.3.

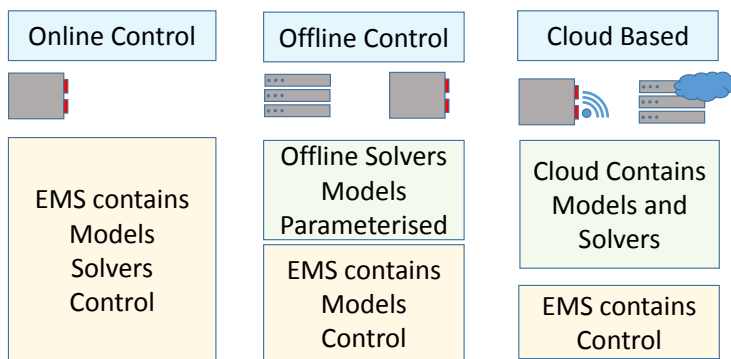

Figure 4.3: Possible route prediction based control implementation structures

## 4.5 Current infrastructure

The European rapid assistance system for automotive collisions, eCall is mandatory for all cars manufactured since April 2018. The Minimum Set of Data (MSD) list from eCall implementation suggests that all manufacturers are ready with systems that support broadcasting information [63]. Commercial offers on today's market for connected services include over the air updates, emergency assistance, road side assistance, climate control, driver

statistics, concierge services, traffic aware routing etc.,. These have shown wide acceptance and willingness by users to pay for such services. The legal requirement and penetration of connected services has made hardware and the associated infrastructure necessary for processing vehicle data available.

Engine control diagnostic loggers have existed since a long time. These usually contain key statistics of vehicle usage that is usually quite wide varying from engine load operations, ambient temperature measurements etc.,. Such data could help classify vehicle operation characteristics. Traffic information system such as google services provide real time traffic updates and even optimal routes for better driving experience. These systems have the necessary infrastructure to provide key data necessary for look ahead prediction. The quality of such a prediction of vehicle speed depend on careful fusion of data. Connected cars that can merge driver route history, position and traffic information system are necessary for route prediction based control as shown in the Fig. 4.4.

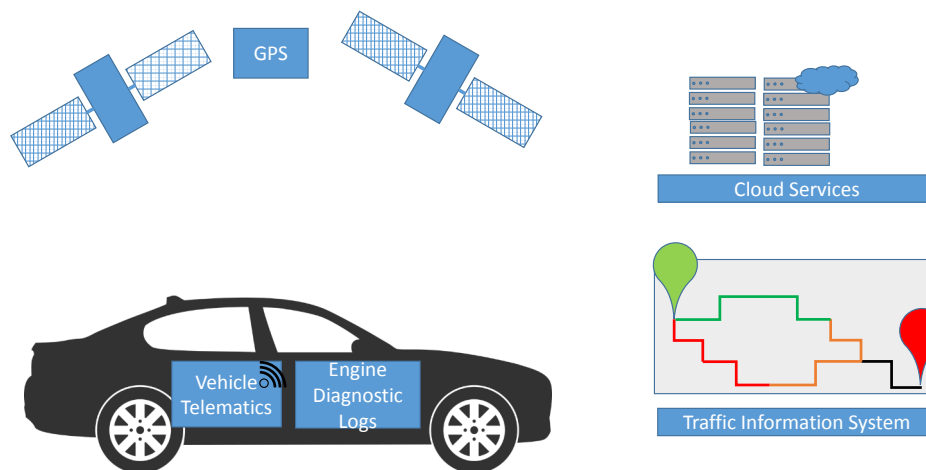

Figure 4.4: Infrastructure required for look ahead prediction and control adaptation: Positioning systems, On board vehicle data communication, cloud services and Traffic information system.

In summary, today's vehicles are connected and data transfer is already possible in both directions. Cloud services also exist and can provide computational ability and adaptation to newer algorithms independent of on board vehicle hardware. Adding data that is logged in the EMS to the data transmitted would be a huge benefit to predict route and drive characteristics.

# Chapter 5

## Contribution and Future work

### 5.1 Contributions

Using the subsystem analysis described in 3.5, an objective function with equivalent fuel consumption of the diesel engine is framed. LNT-SCR co-ordination for  $\text{NO}_x$  aftertreatment complying with exhaust emission constraints while also minimising equivalent fuel consumption is taken up as the first problem to solve. An interface with  $\text{NO}_x$  conversion efficiency is used considering the holistic perspective of the system as motivated in 3.5. Segmentation of look ahead information is used while considering discrete action sets of controls. After the control structure is designed, discrete engine control modes are introduced to add the engine as a subsystem. The segmentation is reviewed considering the response times of the subsystem. The optimisation procedure is to run discrete action cases of the subsystems with the introduced interface on the simulation models of the subsystems. In order to carry out the work online the ECU, lumped parameter models are used to evaluate the discrete action sequences. The controllers are evaluated on the simulation platform using variations of the Worldwide harmonised Light vehicle Test Cycle (WLTC).

#### 5.1.1 Problem Statement

The objective of the control problem is to minimise fuel and urea consumption grouped as engine cost  $C_{\text{Engine}}$  and EATS cost  $C_{\text{EATS}}$  using engine  $u_{\text{Engine}}$  and EATS  $u_{\text{EATS}}$  controls from the beginning of the driving cycle at time  $T_0$  to the end of the cycle at time  $T_f$  while fulfilling  $\text{NO}_x$  legislated tailpipe  $\dot{m}_{\text{NO}_x}^{\text{tp}}$  requirements. The optimisation problem is expressed as:

$$\begin{aligned}
 & \min_{u_{\text{EATS}}, u_{\text{Engine}}} \int_{T_0}^{T_f} C_{\text{Engine}} + C_{\text{EATS}} dt \\
 & \text{s.t.} \quad \frac{\int_{t_0}^{t_1} \dot{m}_{\text{NO}_x}^{\text{tp}} dt}{\int_{t_0}^{t_1} V_{\text{speed}} dt} \leq C_f * 80(\text{mg/km})
 \end{aligned} \tag{5.1}$$

A formulation for the cost function in fuel equivalent terms is derived for usage in control optimisation. The cost of engine fuel usage is used as a direct term to arrive at  $C_{\text{Engine}}$ . The EATS cost  $C_{\text{EATS}}$  is derived by the combination of equivalent fuel components of urea used by the SCR  $m_{\text{urea}}$  and fuel used by the LNT  $m_f^{\text{LNT}}$ . Apart from them costs for difference between initial and final catalyst states of LNT  $\tilde{\theta}_{\text{NO}_x}$  and SCR  $\tilde{\theta}_{\text{NH}_3}$  is used. The methodology behind the costs are detailed in [1–3]. The EATS cost are summarised below:

$$\begin{aligned}
 C_{\text{EATS}} &= C * \theta_{\text{EATS}}^T \\
 C &= [C_1 \quad C_{11} \quad C_2 \quad C_{22} \quad C_3] \\
 \theta_{\text{EATS}} &= [m_{\text{urea}} \quad \tilde{\theta}_{\text{NH}_3} \quad m_f^{\text{LNT}} \quad \tilde{\theta}_{\text{NO}_x} \quad m_{\text{NO}_x}^{\text{tp}}]^T \\
 \tilde{\theta}_{\text{NO}_x} &= \theta_{\text{NO}_x}^{\text{final}} - \theta_{\text{NO}_x}^{\text{initial}} \\
 \tilde{\theta}_{\text{NH}_3} &= \theta_{\text{NH}_3}^{\text{initial}} - \theta_{\text{NH}_3}^{\text{final}}
 \end{aligned} \tag{5.2}$$

### 5.1.2 Proposed control architecture

A control architecture is proposed for coordinating subsystems that differ in their nature of response time and complexity in system objective. A discrete control action set enables the applicability of such a control architecture in conjunction with the subsystem interface. The discrete control action sets for the engine, LNT and the SCR subsystem are derived. The idea to use discrete control action sets is to minimise the computational requirement to optimise the control problem. While this may come at a cost of losing optimum, the decision for this approach is motivated by its usability in a standard EMS on board the vehicle.

The engine action set is a choice between two sets of actuator maps with objective of (1) attaining low engine out  $\text{NO}_x$  when the EATS has a lower  $\text{NO}_x$  conversion efficiency  $\text{Low}_{\text{NO}_x}$  and (2) achieving best fuel consumption when the EATS is capable of higher  $\text{NO}_x$  conversion  $\text{Low}_{\text{CO}_2}$ . The choice of 2 engine modes provides for simplicity in the interface and computation while it does come at an unknown cost from the optimal control.

The control interface for the LNT is the choice of a factor that modifies the target threshold for LNT regeneration. A low factor ( $<1$ ) would result in

a lower threshold than default leading to more frequent regeneration thereby more  $\text{NO}_x$  conversion efficiency through the LNT. The fuel consumption would thus be higher. The vice-versa would be applicable for a higher factor. A discrete choice of three factors  $\eta_{\text{LNT}}^{\text{Low}}, \eta_{\text{LNT}}^{\text{Medium}}, \eta_{\text{LNT}}^{\text{High}}$  is used in the LNT interface. This provides for a reasonable estimate when the LNT is used to its maximum possible efficiency, minimum possible and also a middle ground between the two. The discrete choices enable a quick estimation of costs for the optimisation.

Similar to the LNT, the control interface for the SCR is obtained by modifying target buffer for ammonia in the SCR using a multiplication factor. A higher factor ( $=1$ ) would lead to maximum  $\text{NH}_3$  target buffer thus resulting in higher  $\text{NO}_x$  conversion from the SCR at the cost of higher urea consumption. The reverse is true for a lower factor. A choice of three factors  $\eta_{\text{SCR}}^{\text{Low}}, \eta_{\text{SCR}}^{\text{Medium}}, \eta_{\text{SCR}}^{\text{High}}$  is used so as to obtain a reasonable spread between the conversion efficiencies. Summary of control actions used in the scheme are:

$$\begin{aligned} u_{\text{Engine}} &\in \{\text{Low}_{\text{NO}_x}, \text{Low}_{\text{CO}_2}\} \\ u_{\text{EATS}} &= [u_{\text{LNT}}, u_{\text{SCR}}]^T \\ u_{\text{LNT}} &\in \{\eta_{\text{LNT}}^{\text{Low}}, \eta_{\text{LNT}}^{\text{Medium}}, \eta_{\text{LNT}}^{\text{High}}\} \\ u_{\text{SCR}} &\in \{\eta_{\text{SCR}}^{\text{Low}}, \eta_{\text{SCR}}^{\text{Medium}}, \eta_{\text{SCR}}^{\text{High}}\} \end{aligned}$$

Using discrete action sets would come at an additional cost from the optimal control. It could be argued that true optimality can be achieved only in case of complete knowledge of the drive cycle. Since only an estimated trajectory is assumed to be known, which is prone to change as the cycle progresses, adaptation to the change is significant to realise any potential improvement over the baseline control. Hence, comparison of controllers in this work is done with the baseline controller performance. Apart from the uncertainty in the drive cycle, the computation time required for such a discrete number of action combination is less and hence is the approach chosen here. The architecture derived is shown in Fig. 5.1.

### 5.1.3 Supervisory control optimisation

The supervisory control interface is defined considering look ahead segmentation. The system analysis helped in defining the subsystem interface by focussing on the phenomenon leading to the supervisory control interface. The optimisation algorithm considered here is to use the look ahead trajectory and calculate the lowest cost control action combination set for each segment of the trajectory. This is applied as the supervisory control set point.

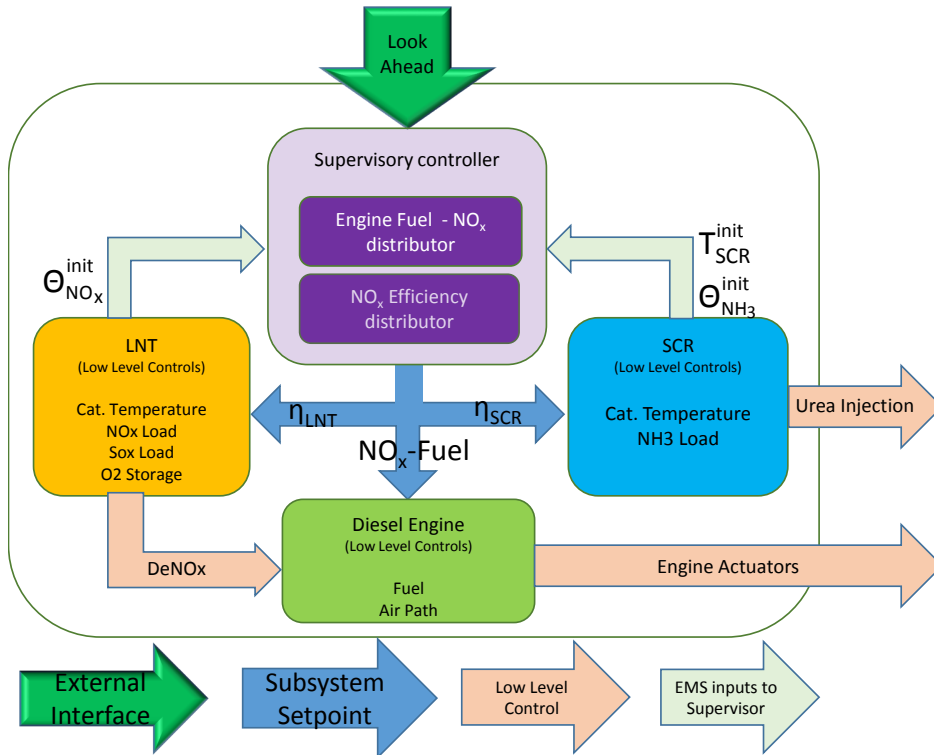

Figure 5.1: Supervisory control architecture with interface

In a first approach, the trajectory is broken into small segments. The idea is to develop a characterisation algorithm and classify these segments. Each classified segment is optimised off-line by considering the discrete control action set and is parametrised by the engine, catalyst states and the segment type. This is stored on-board the ECU and applied for each segment. This approach is detailed in [2].

In an alternative approach, a lumped model for the subsystems is used. This is driven by the complete segment and the cumulative effect is modelled. The discrete set of control actions is simulated and optimal control action is arrived. The lumped models are a combination of lookup tables and simple parameters. Being computationally non intensive, these models are intended to be fast and hence possible to implement in the EMS. This approach is detailed in [3].

In both approaches described above, a full factorial estimate is done with all the discrete actions from the subsystems. The action set combination that guarantees the emission constraints while having the lowest equivalent fuel consumption is chosen and applied as the supervisory control set point

for the upcoming segment in the drive cycle.

#### 5.1.4 Potential with Supervisory controller

In [1], the supervisory controller's ability using look ahead data to balance the  $\text{NO}_x$  conversion between the two subsystems (LNT-SCR) to minimise equivalent consumption is demonstrated. In [2, 3], the same is extended including the combustion engine where around 1% equivalent fuel saving is achieved compared to the baseline controller. The equivalent fuel saving while guaranteeing controlled exhaust emissions without altering the underlying local level controllers is demonstrated for almost all cases using simulation with a number of cycles generated using WLTC segments.

## 5.2 Future work

Control validation results of the approach taken and the segmentation will be the subject of future research work. The approach might also be extended with a focus on the next promising electrified powertrain layout which inherently has complex subsystems owing to strategic shift and market trend in passenger car propulsion.

### 5.2.1 Drive cycle characterisation

Characterising segments are used in the initial works. However, to fully utilise segment identification and parametrisation, sensitivity of optimal control to parametrised segment based control is needed. The methodology to characterise, classify and thus develop clustered control policies with data available will be focussed upon. The best practice to predict the sensitive prediction parameters shall be determined using historic log of geotagged vehicle operation.

### 5.2.2 Verification of control proposals

The proposed control schematic shall be verified on physical test objects such as a vehicle in the emission test cell to show proof of concept in real time. Focus on real world performance and disturbance handling will be looked upon while also comparing against the baseline control. A drive cycle that is representative of real world challenges will be determined for usage.

### 5.2.3 Inclusion of mild hybridisation

Inclusion of mild hybrids with electric Kinetic Energy Recovery System (KERS) is within the scope of the project. KERS offers potential in fuel saving and emission control by shifting engine operating point, peak torque shaving, quick heat up of catalyst, regenerative braking to list a few. The degree of freedom offered by KERS needs a careful integration in the supervisory controller.

## 5.3 Summary of Included Papers

### Paper I

Dhinesh Velmurugan, Daniel Lundberg and Tomas McKelvey, "Supervisory Controller for a LNT-SCR Diesel Exhaust After-Treatment System", European Control Conference, June 2018, Limassol, Cyprus.

In this paper, as the first subproblem, the LNT-SCR coordination is explored in the context of developing a supervisory controller for the diesel powertrain while using look ahead information. An interface that indirectly controls the  $\text{NO}_x$  conversion efficiency of the LNT and the SCR is developed. A controller that minimises Emission Equivalent Fuel Consumption (EEFC) is proposed. Using the engine speed and torque trajectory from a WLTC cycle segmented in parts, controller setpoints for the defined objective is calculated using simulation of the subsystem models. The result is compared to a conventional rule based controller used for the LNT-SCR coordination under different initial catalyst conditions and differently arranged sequenced WLTC parts.

### Paper II

Dhinesh Velmurugan, Tomas McKelvey and Daniel Lundberg, "Supervisory controller for a Light Duty Diesel Engine with an LNT-SCR After-Treatment System", International Powertrains, Fuels & Lubricants Meeting, SAE International, September 2018, Heidelberg, Germany.

In this paper, the complexity of the developed LNT-SCR controller is extended by the addition of the combustion engine as a third subsystem. The same interface is carried over. For the combustion engine, 2 discrete modes are chosen with 2 distinct objectives. The first mode has the objective of least engine exhaust  $\text{NO}_x$  while compromising on fuel consumption. The



second mode has the objective of least fuel consumption while compromising on engine exhaust  $\text{NO}_x$  emissions when the EATS is warmed. In this approach, the drive cycle is broken into 60s segments. The LNT-SCR  $\text{NO}_x$  conversion efficiency interface is made discrete with 3 levels that reduces the computational effort for the controller. A full factorial simulation of the combination of engine-LNT-SCR actions is done to determine the least equivalent fuel consumption combination that satisfies the emission constraints. The result is compared to the rule based controller used for the engine-LNT-SCR coordination under different catalyst conditions and sequenced WLTC.

### Paper III

Dhinesh Velmurugan, Daniel Lundberg and Tomas McKelvey, "Look Ahead based Supervisory Control of a Light Duty Diesel Engine", IFAC Conference on Engine and Powertrain Control, Simulation and Modeling (E-COSM'18), September 2018, Changchun, China.

In this paper, the full factor simulation of the discrete combination of control actions is focussed. A lumped parameter based model for each of the subsystems is used instead of the full scale model of the subsystems. The simplicity of the lumped models enable implementation of the controller in a real time ECU. The lumped models are calibrated to be accurate enough for cumulative effects within the look ahead segment being considered. The use of such a model for supervisory control is investigated. The same interface and discrete action controls defined in the early paper is used. The look ahead information in each segment for 18 combination of control actions (3 LNT, 3 SCR and 2 Engine modes) is evaluated using the lumped models. In comparison with using the complex models [2], the resulting average equivalent fuel consumption saving is similar in the order of 1% while fulfilling exhaust emission constraints.



# References

- [1] D. Velmurugan, D. Lundberg, and T. McKelvey, “Supervisory controller for a LNT-SCR diesel exhaust after-treatment system”, in *2018 European Control Conference*, 2018.
- [2] D. Velmurugan, T. McKelvey, and D. Lundberg, “Supervisory controller for a light duty diesel engine with an LNT-SCR after-treatment system”, in *International Powertrains, Fuels & Lubricants Meeting*, SAE International, 2018.
- [3] D. Velmurugan, D. Lundberg, and T. McKelvey, “Look ahead based supervisory control of a light duty diesel engine”, in *IFAC Conference on Engine and Powertrain Control, Simulation and Modeling*, 2018.
- [4] International Organization of Motor Vehicle Manufacturers. (2016). Passenger car world vehicles in use, [Online]. Available: <http://www.oica.net/category/vehicles-in-use>.
- [5] H. Ritchie and M. Roser. (2018). Co2 and other greenhouse gas emissions, [Online]. Available: <https://ourworldindata.org/co2-and-other-greenhouse-gas-emissions>.
- [6] European Environment Agency, “European Union emission inventory report 1990-2015 under the UNECE convention on long-range transboundary air pollution”, European Environment Agency, Report, 2017.
- [7] US EPA, “Inventory of U.S. greenhouse gas emissions and sinks: 1990 - 2016”, US Environmental Protection Agency, Report, 2018.
- [8] IPCC, “Climate change 2013: the physical science basis. contribution of working group I to the fifth assessment report of the intergovernmental panel on climate change”, IPCC, Report, 2013.
- [9] Food and Agriculture Organization of the United Nations. (2017). Emissions by sector: transport emissions, [Online]. Available: <http://www.fao.org/faostat/en/?#data/>.

## REFERENCES

- [10] Trafikanalys. (Official statistics of Sweden). Vehicle statistics, [Online]. Available: <https://www.trafa.se/en/road-traffic/vehicle-statistics/>.
- [11] Statistics Netherlands, “Transport and mobility 2016”, Statistics Netherlands, Report, 2016.
- [12] European commission. (2017). Proposal for post-2020 CO2 targets for cars and vans, [Online]. Available: [https://ec.europa.eu/clima/policies/transport/vehicles/proposal\\_en](https://ec.europa.eu/clima/policies/transport/vehicles/proposal_en).
- [13] S. Tsiakmaki et al., “From NEDC to WLTP: effect on the type-approval CO2 emissions of light-duty vehicles”, Joint Research Center, European Commission, Report, 2017.
- [14] G. Fontaras et al., “The difference between reported and real-world CO2 emissions: how much improvement can be expected by WLTP introduction?”, *Transportation Research Procedia*, vol. 25, pp. 3933 – 3943, 2017, World Conference on Transport Research - WCTR 2016 Shanghai. 10-15 July 2016.
- [15] European Environment Agency, “Understanding pollutant emissions from Europe’s cities”, European Environment Agency, Report, 2013.
- [16] U.S. Environmental Protection Agency, “Health assessment document for diesel engine exhaust”, National Center for Environmental Assessment, Washington, DC, for the Office of Transportation and Air Quality, Report, 2002.
- [17] European Environment Agency. (2017). Emissions of the main air pollutants in Europe, [Online]. Available: <https://www.eea.europa.eu/data-and-maps/indicators/main-anthropogenic-air-pollutant-emissions/assessment-5>.
- [18] N. Hooftman et al., “A review of the European passenger car regulations real driving emissions vs local air quality”, *Renewable and Sustainable Energy Reviews*, vol. 86, pp. 1 –21, 2018.
- [19] M. Weiss et al., “Will Euro 6 reduce the NOx emissions of new diesel cars? - insights from on-road tests with portable emissions measurement systems (PEMS)”, *Atmospheric Environment*, vol. 62, pp. 657 –665, 2012.
- [20] G. Triantafyllopoulos et al., “Experimental assessment of the potential to decrease diesel NOx emissions beyond minimum requirements for Euro 6 real drive emissions (RDE) compliance”, *Science of The Total Environment*, vol. 618, pp. 1400 –1407, 2018.

## REFERENCES

- [21] European Automobile Manufacturers' Association. (2017). Euro 6 RDE data, [Online]. Available: <http://www.acea.be/publications/article/access-to-euro-6-rde-monitoring-data>.
- [22] J. Heywood, *Internal Combustion Engine Fundamentals*, ser. Automotive technology series. McGraw-Hill, 1988.
- [23] K. Reif et al., *Automotive Handbook*. Robert Bosch GmbH, 2014.
- [24] K. M. Shaaban, S. Alec, and K. John, "Study of EGR and turbocharger combinations and their influence on diesel engine's efficiency and emissions", in *SAE 2016 World Congress and Exhibition*, SAE International, Apr. 2016.
- [25] T. Johnson, "Vehicular emissions in review", *SAE International Journal of Engines*, vol. 7, no. 3, pp. 1207–1227, Apr. 2014.
- [26] A. Russell and W. S. Epling, "Diesel oxidation catalysts", *Catalysis Reviews*, vol. 53, no. 4, pp. 337–423, 2011.
- [27] J. P. Neeft, M. Makkee, and J. A. Moulijn, "Diesel particulate emission control", *Fuel Processing Technology*, vol. 47, no. 1, pp. 1–69, 1996.
- [28] W. S. Epling et al., "Overview of the fundamental reactions and degradation mechanisms of NOx storage/reduction catalysts", *Catalysis Reviews*, vol. 46, no. 2, pp. 163–245, 2004.
- [29] I. Nova and E. Tronconi, *Urea-SCR technology for deNOx after treatment of diesel exhausts*. Springer, 2014.
- [30] H. Nouraei, R. Ben-Mrad, and A. N. Sinclair, "Development of a piezoelectric fuel injector", *IEEE Transactions on Vehicular Technology*, vol. 65, no. 3, pp. 1162–1170, Mar. 2016.
- [31] M. Mrosek and R. Isermann, "System properties and control of turbocharged diesel engines with high- and low-pressure EGR", *IFAC Proceedings Volumes*, vol. 42, no. 26, pp. 56–63, 2009, 2nd IFAC Workshop on Engine and Powertrain Control, Simulation and Modeling.
- [32] Robert Bosch GmbH, *Bosch Automotive Electrics and Automotive Electronics*, 5th. Springer. Wiesbaden., 2014.
- [33] J. Wahlström and L. Eriksson, "Modelling diesel engines with a variable-geometry turbocharger and exhaust gas recirculation by optimization of model parameters for capturing non-linear system dynamics", *Proceedings of the Institution of Mechanical Engineers, Part D: Journal of Automobile Engineering*, vol. 225, no. 7, pp. 960–986, 2011.

## REFERENCES

- [34] A. G. Stefanopoulou, I. Kolmanovsky, and J. S. Freudenberg, “Control of variable geometry turbocharged diesel engines for reduced emissions”, *IEEE Transactions on Control Systems Technology*, vol. 8, no. 4, pp. 733–745, Jul. 2000.
- [35] M. Ammann et al., “Model-based control of the VGT and EGR in a turbocharged common-rail diesel engine: theory and passenger car implementation”, in *SAE 2003 World Congress & Exhibition*, SAE International, Mar. 2003.
- [36] M. Grahn, K. Johansson, and T. McKelvey, “Model-based diesel engine management system optimization for transient engine operation”, *Control Engineering Practice*, vol. 29, pp. 103–114, 2014.
- [37] E. R. Gelso and J. Dahl, “Air-path control of a heavy-duty EGR-VGT diesel engine”, *IFAC-PapersOnLine*, vol. 49, no. 11, pp. 589–595, 2016, 8th IFAC Symposium on Advances in Automotive Control AAC 2016.
- [38] C. Westerlund et al., “Model predictive control of a combined EGR/SCR HD diesel engine”, in *SAE 2010 World Congress & Exhibition*, SAE International, Apr. 2010.
- [39] P. Chen and J. Wang, “Control-oriented model for integrated diesel engine and aftertreatment systems thermal management”, *Control Engineering Practice*, vol. 22, pp. 81–93, 2014.
- [40] R. Cloudt and F. Willems, “Integrated emission management strategy for cost-optimal engine-aftertreatment operation”, *SAE International Journal of Engines*, vol. 4, no. 1, pp. 1784–1797, Apr. 2011.
- [41] S. Zentner et al., “An equivalent emission minimization strategy for causal optimal control of diesel engines”, *Energies*, vol. 7, no. 3, pp. 1230–1250, 2014.
- [42] D. Hrovat et al., “The development of model predictive control in automotive industry: a survey”, in *2012 IEEE International Conference on Control Applications*, Oct. 2012, pp. 295–302.
- [43] F. R. Salmasi, “Control strategies for hybrid electric vehicles: evolution, classification, comparison, and future trends”, *IEEE Transactions on Vehicular Technology*, vol. 56, no. 5, pp. 2393–2404, Sep. 2007.
- [44] S. G. Wirasingha and A. Emadi, “Classification and review of control strategies for plug-in hybrid electric vehicles”, *IEEE Transactions on Vehicular Technology*, vol. 60, no. 1, pp. 111–122, Jan. 2011.

- [45] A. Panday and H. O. Bansal, “A review of optimal energy management strategies for hybrid electric vehicle”, *International Journal of Vehicular Technology*, vol. 2014, p. 19, 2014.
- [46] W. Enang and C. Bannister, “Modelling and control of hybrid electric vehicles (a comprehensive review)”, *Renewable and Sustainable Energy Reviews*, vol. 74, pp. 1210–1239, 2017.
- [47] C. Musardo et al., “A-ECMS: an adaptive algorithm for hybrid electric vehicle energy management”, *European Journal of Control*, vol. 11, no. 4, pp. 509–524, 2005.
- [48] E. Finkeldei and M. Back, “Implementing an MPC algorithm in a vehicle with a hybrid powertrain using telematics as a sensor for powertrain control”, *IFAC Proceedings Volumes*, vol. 37, no. 22, pp. 433–438, 2004, IFAC Symposium on Advances in Automotive Control 2004, Salerno, Italy, 19-23 April 2004.
- [49] A. Sciarretta and L. Guzzella, “Control of hybrid electric vehicles”, *IEEE Control Systems*, vol. 27, no. 2, pp. 60–70, Apr. 2007.
- [50] T. J. Böhme and B. Frank, *Hybrid Systems, Optimal Control and Hybrid Vehicles*. 2017.
- [51] H. W. Kaas et al., “Automotive revolution perspective towards 2030”, McKinsey & Company, Report, 2016.
- [52] A. Habeck et al., “Connected car, automotive value chain unbound”, McKinsey & Company, Report, 2014.
- [53] J. Froehlich and J. Krumm, “Route prediction from trip observations”, in *SAE World Congress & Exhibition*, SAE International, Apr. 2008.
- [54] M. Montazeri-Gh, A. Fotouhi, and A. Naderpour, “Driving patterns clustering based on driving features analysis”, *Proceedings of the Institution of Mechanical Engineers, Part C: Journal of Mechanical Engineering Science*, vol. 225, no. 6, pp. 1301–1317, 2011.
- [55] K. Liu, T. Yamamoto, and T. Morikawa, “Impact of road gradient on energy consumption of electric vehicles”, *Transportation Research Part D: Transport and Environment*, vol. 54, pp. 74–81, 2017.
- [56] J. Lohrer, M. Förth, and M. Lienkamp, “A data-driven predictive energy management strategy for plug-in hybrid vehicles”, in *2017 International Conference on Mechanical, System and Control Engineering (ICMSC)*, May 2017, pp. 297–304.

## REFERENCES

- [57] J. Lohrer and M. Lienkamp, “Building representative velocity profiles using fast DTW and spectral clustering”, in *2015 14th International Conference on ITS Telecommunications (ITST)*, Dec. 2015, pp. 45–49.
- [58] E. Ericsson, “Independent driving pattern factors and their influence on fuel-use and exhaust emission factors”, *Transportation Research Part D: Transport and Environment*, vol. 6, no. 5, pp. 325–345, 2001.
- [59] J. Gallus et al., “Impact of driving style and road grade on gaseous exhaust emissions of passenger vehicles measured by a portable emission measurement system (PEMS)”, *Transportation Research Part D: Transport and Environment*, vol. 52, pp. 215–226, 2017.
- [60] P. Guzay et al., “Driving and parking patterns of European car drivers a mobility survey”, Institute for Energy and Transport, Report, 2012.
- [61] V. Pollex et al., “Sufficient real-time analysis for an engine control unit with constant angular velocities”, in *2013 Design, Automation Test in Europe Conference Exhibition (DATE)*, Mar. 2013, pp. 1335–1338.
- [62] I. Park et al., “Resource-aware integration of AUTOSAR-compliant ECUs with an empirical wceet prediction model”, *International Journal of Automotive Technology*, vol. 17, no. 4, pp. 717–729, Aug. 1, 2016.
- [63] J. Carroll et al., “Technical requirements and test procedures for the type-approval of eCall in-vehicle systems”, TRL limited, Report, 2015.