



CHALMERS
UNIVERSITY OF TECHNOLOGY

Josephson junction qubit network with current-controlled interaction

Downloaded from: <https://research.chalmers.se>, 2019-05-11 19:34 UTC

Citation for the original published paper (version of record):

Lantz, J., Wallquist, M., Shumeiko, V. et al (2004)

Josephson junction qubit network with current-controlled interaction

Physical Review B, 70

<http://dx.doi.org/10.1103/PhysRevB.70.140507>

N.B. When citing this work, cite the original published paper.

Josephson junction qubit network with current-controlled interaction

J. Lantz, M. Wallquist, V. S. Shumeiko, and G. Wendin

Department of Microtechnology and Nanoscience, Applied Quantum Physics Laboratory, Chalmers University of Technology, SE-41296 Gothenburg, Sweden

(Received 8 July 2004; published 14 October 2004)

We design and evaluate a scalable charge qubit chain network with controllable current-current coupling of neighboring qubit loops via local dc-current gates. The network allows construction of general N -qubit gates. The proposed design is in line with current main stream experiments.

DOI: 10.1103/PhysRevB.70.140507

PACS number(s): 74.81.Fa, 03.67.Lx, 85.25.Hv, 85.25.Cp

Although a working solid-state quantum computer with hundreds of qubits remains a distant goal, coupling of a few solid-state qubits is now becoming feasible. Several groups have succeeded in performing advanced operations with single Josephson junction (JJ) qubits,¹⁻⁷ but the art of multiple JJ qubit gates is still in its infancy. A few challenging experiments with coupled JJ qubits have been reported.^{6,8-12} However, so far experiments on coupled JJ qubits have been performed without direct physical control of the qubit-qubit coupling.

There are many proposed schemes for two(multi)-qubit gates where an effective qubit coupling is controlled by tunings of qubits or bus resonators.¹³⁻¹⁶ However, there are also suggestions how to control physical qubit interaction,¹⁷⁻²¹ most of which require local magnetic field control. Recently, Yamamoto *et al.*¹¹ successfully implemented a controlled-NOT (CNOT) gate using fixed capacitive coupling between two charge qubits, controlling the effective qubit-qubit interaction by tuning single-qubit level splittings into resonance. However, this method might not be well suited for more advanced gates on charge qubits because of strong decoherence when qubits are operated away from the degeneracy points.

In this paper we present a solution for controllable physical qubit-qubit coupling, as shown in Fig. 1. The network has the following properties: (a) nearest-neighbor qubit-qubit coupling controlled by external bias current, (b) qubits parked at the degeneracy points, also during qubit-qubit interaction, (c) separate knobs for controlling individual qubits and qubit-qubit coupling, and (d) scalability. An important feature is that the network is easily fabricated, and is in line with current mainstream experiments.

The network under consideration consists of a chain of charge qubits—single Cooper pair transistors (SCT)—with loop-shaped electrodes coupled together by current biased coupling JJs at the loop intersections (Fig. 1). The loop-shaped electrode was introduced^{1,14} to provide external control of the Josephson coupling of the qubit island to the reservoir. The loop design creates an (inductive) interface to the qubit by means of circulating currents,²² which has been used as a tool for qubit readout by Vion *et al.*³ We employ these current states in the qubit loops to create controllable coupling of neighboring qubits. The results of this paper are derived in the charge qubit limit $E_C \gg E_J$. However, the analysis and the coupling mechanism also apply to the case of $E_C \approx E_J$, describing the charge-phase qubit.³

Left without any external current biasing of the coupling and readout JJs, the network acts as a quantum memory of independent qubits (neglecting a weak residual interaction, to be discussed below). When a bias current is sent through the coupling JJ in Fig. 1, the current-current interaction between the neighboring qubits is switched on and increases with increasing bias current. Moreover, if *both* of the readout JJs of the same qubits are biased well below threshold, again there is nearest-neighbor coupling via the circulating currents.²⁵ However, if *one* of the readout JJs is current biased, this only affects that particular qubit and allows the readout of individual qubits. Thus the bias currents serve as the interaction control knobs. The loop inductances are assumed to be sufficiently small to neglect qubit-qubit coupling via induced magnetic flux, as well as undesirable qubit coupling to the magnetic environment. In addition, we as-

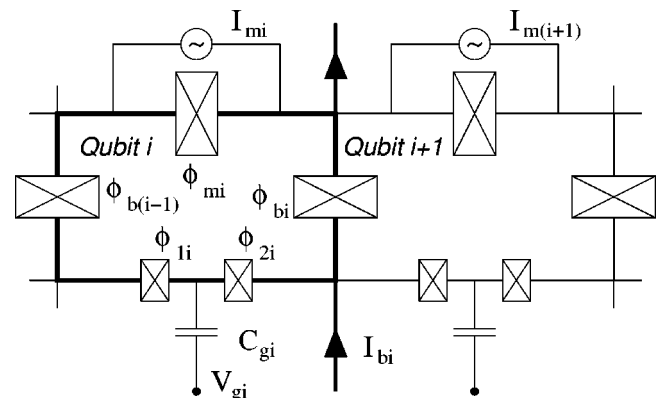

FIG. 1. Network of loop-shaped SCT charge qubits, coupled by large Josephson junctions. The interaction of the qubits (i) and ($i+1$) is controlled by the current bias I_{bi} or by simultaneous current biasing of readout junctions. Individual qubits are controlled by voltage gates V_{gi} . Single-qubit readout is performed by applying an ac (Ref. 23) or dc (Ref. 3) current pulse I_{mi} to a particular JJ readout junction. Alternatively, readout of a charge may be performed, e.g., using a rf-SET (single-electron transistor) capacitively coupled to the island (Ref. 24). The two Josephson junctions of the i th SCT are assumed to have identical Josephson energies E_{Ji} . The Josephson energies of the coupling JJs E_{Jb} and the readout JJs E_{Jm} (identical for simplicity) are much larger than the corresponding charging energies, $E_{Jb} \gg E_{Cb}$. ϕ_{bi} (ϕ_{mi}) is the phase difference across the i th coupling (readout) JJ. For an open N -qubit chain we choose $\phi_{b0} = \phi_{bN} = 0$, while for a closed chain $\phi_{b0} = \phi_{bN}$.

sume negligible capacitive coupling between the islands, which are well shielded by the injection leads.

The SCT qubit chain system shown in Fig. 1 is described by the Hamiltonian

$$\mathcal{H} = \sum_i (H_i^{\text{SCT}} + H_{bi}^{\text{OSC}} + H_{mi}^{\text{OSC}}), \quad (1)$$

where $H_i^{\text{SCT}} = (E_{Ci}/2)(1 - n_{gi})\sigma_{zi} - E_{Ji} \cos \theta_i \sigma_{xi}$, using the Pauli matrix representation, and where $H_{bi}^{\text{OSC}} = Q_i^2/2C_b - E_{Jb} \cos \phi_{bi} - (\hbar/2e)I_{bi}\phi_{bi}$ is the Hamiltonian of the coupling JJ. H_{mi}^{OSC} is the similar Hamiltonian of the readout junction, which for simplicity is chosen with the same parameters. The induced gate charge on the i th SCT island is $en_{gi} = C_{gi}V_{gi}$; the charging energy of which is defined by $E_{Ci} = (2e)^2/2C_{\Sigma}$. Finally, Q_i is the charge on each coupling JJ obeying the commutation relations $[Q_i, \phi_{bj}] = 2ie\delta_{ij}$. H_i^{SCT} has been truncated to the two lowest charge states, assuming $E_{Ci} \gg E_{Ji}$ and $n_{gi} \approx 1$, and a small correction to the charging energy of the coupling JJs ($\sim C_i/C_b \ll 1$) has been neglected. Flux quantization in every loop $\phi_{1i} + \phi_{2i} - 2\theta_i = 0$, where $\theta_i = (\phi_{bi} - \phi_{b(i-1)} - \phi_{mi})/2$ (assuming zero external flux) introduces a dependence of the qubit Josephson energy on the phase differences across the coupling and readout JJs. This qubit-oscillator interaction is the origin of the qubit-qubit interaction.

For proper functioning of the network, the critical conditions are $E_{Jb} \gg \hbar\omega_p, E_J$, where ω_p is the plasma frequency of the coupling JJs, establishing the phase regime for the coupling JJs with small fluctuations of phase $\delta_i = \phi_{bi} - \bar{\phi}_{bi}$, $\langle \delta_i^2 \rangle \sim \hbar\omega_p/E_{Jb} \ll 1$, around energy minima determined by the control current, $\sin \bar{\phi}_{bi} = I_{bi}/I_{cb}$. We only consider the regime of negligible macroscopic quantum tunneling (MQT).

Using a harmonic approximation for the periodic potential terms in Eq. (1), all coupling JJs are reduced to harmonic oscillators with level spacing $\hbar\omega_p = \sqrt{2\epsilon_{bi}E_{Cb}}$, where $\epsilon_{bi} = E_{Jb} \cos \bar{\phi}_{bi}$. Each SCT term in Eq. (1) is then, in the lowest approximation with respect to harmonic amplitudes, reduced to a qubit Hamiltonian,

$$H_{qi} = \frac{E_{Ci}}{2}(1 - n_{gi})\sigma_{zi} - E_{Ji} \cos \bar{\theta}_i \sigma_{xi}, \quad (2)$$

where $\bar{\theta}_i = (\bar{\phi}_{bi} - \bar{\phi}_{b(i-1)} - \bar{\phi}_{mi})/2$, $\sin \bar{\phi}_{mi} = I_{mi}/I_{cm}$, plus a linear oscillator-qubit interaction, $H_{\text{int},i}^{(1)} = \lambda_i(\delta_i - \delta_{i-1})\sigma_{xi}$, proportional to the coupling strength $\lambda_i = (E_{Ji}/2)\sin \bar{\theta}_i$ and to the phase deviation in the coupling JJs. This generates controllable nearest-neighbor qubit interaction terms which appear only in the presence of bias currents and describe displacement of the oscillators driven by the qubits. There are also quadratic terms, $H_{\text{int},i}^{(2)} = (\epsilon_i/8)(\delta_i - \delta_{i-1})^2\sigma_{xi}$, where $\epsilon_i = E_{Ji} \cos \bar{\theta}_i$, which induce relatively small permanent residual qubit coupling due to oscillator squeezing driven by the qubits.

The harmonic oscillators can with good accuracy be assumed to stay in the ground state during all quantum operations on the network at low temperature. For current control pulse durations $T \gg \omega_p^{-1}$, the probability to excite the oscilla-

tor due to qubit flips away from the degeneracy point is estimated as $W \sim E_{Ci}^2(1 - n_{gi})^2/\hbar\omega_p\epsilon_{Jb} \ll 1$, when the linear qubit-oscillator coupling is switched on ($\lambda_i \sim E_{Ji}$). In the residual interaction regime ($\lambda_i = 0$), the excitation probability is several orders of magnitude ($\hbar\omega_p/E_{Jb} \ll 1$) smaller. Hence, we average over the ground state of the oscillators and finally arrive at the effective Hamiltonian for the qubit network,

$$\mathcal{H} = \sum_i (H_{qi} + \eta_i \sigma_{xi} \sigma_{x(i+1)}) + \sum_{i \neq j} \kappa_{ij} \sigma_{xi} \sigma_{xj}, \quad (3)$$

where $\eta_i = \lambda_i \lambda_{i+1}/\epsilon_{bi}$ and κ_{ij} are the energies of the controllable and the residual interactions, respectively. The maximum controllable interaction energy is a factor of E_J/ϵ_{bi} smaller than the qubit level splitting, $\sim 2E_J$. The residual qubit-qubit interaction effectively connects all of the qubits but it is smaller than the controllable coupling by a factor of $\hbar\omega_p/E_{Jb} \ll 1$.

The interaction energy η_i can be expressed in terms of the currents $I_i = (e/\hbar)E_{Ji} \sin \bar{\theta}_i$ circulating in neighboring qubit loops as $\eta_i = L_{\text{eff}} I_i I_{i+1}$, where $L_{\text{eff}} = \hbar^2/(4e^2\epsilon_{bi})$ is the effective inductance introduced by the coupling JJ.

In order to exclusively couple the qubits (i) and ($i+1$) one should apply a nonzero current bias I_{bi} , while $I_{b(i\pm 1)} = 0$ and $I_{b(i\pm 2)} = 0$. In this case the coupling amplitude is given by the equation

$$\eta_i = - \frac{E_{Ji} E_{J(i+1)}}{4E_{Jb} \cos \bar{\phi}_{bi}} \sin^2 \frac{\bar{\phi}_{bi}}{2}. \quad (4)$$

The coupling is quadratic, $\sim (I_{bi}/I_c)^2$, for small current bias, and diverges when approaching the critical current. An alternative way to switch on the qubit-qubit coupling is to apply dc bias currents (below the critical value) simultaneously to both of the two neighboring readout junctions, instead of activating the coupling junction, resulting in an interaction energy $\eta_i = -(E_{Ji} E_{J(i+1)})/4E_{Jb} \sin \bar{\theta}_i \sin \bar{\theta}_{i-1}$.

The present strategy is to park the qubits at the degeneracy points, where the coherence time is maximum,³ and then to operate with (a) short dc-voltage pulses or, alternatively, microwave resonant excitation, to perform single-qubit operations with qubit-qubit coupling switched off ($\eta = 0$), and with (b) dc-current pulses ($\eta \neq 0$) to perform two-qubit rotations at the degeneracy points.

The readout of individual qubits can be performed by probing the corresponding junction with ac current,²³ while keeping zero bias at the coupling junctions. Since amplitude of the phase oscillation in the readout junction remains small during measurement, our theory applies, and neighboring qubits will not be disturbed. Another option would be to pulse the dc current through the readout junction above the critical value.³ Required that the qubits are operated in the charge regime ($E_C \gg E_J$), readout of the islands charge state is also possible by means of a capacitive probe, e.g., using a SET electrometer.

We now focus on two-qubit gate operation. The Hamiltonian in Eq. (3) is diagonal in the current basis when all qubits are put at the degeneracy points. Considering two

In conclusion, the present scheme provides a realistic solution for easy local control of the physical coupling of charge qubits via current biasing of coupling Josephson junctions or, alternatively, pairs of readout junctions. The design is in line with experimental mainstream development of charge qubit circuits and can easily be fabricated and tested experimentally. Most importantly, it allows readout via currently tested methods that promise single-shot projective measurement and even nondestructive measurements via, e.g., a rf-reflection readout of a JJ threshold detector²³ or an SET.^{4,24} The tunable coupling of the qubit chain allows easy implementation of CNOT and CNOT-SWAP operations.

Independent two-qubit operations can be performed in parallel when the network consists of five qubits or more, and generalization to single-shot N -qubit gates seems possible. This may offer interesting opportunities for operating qubit clusters in parallel and teleporting qubits along the chain, for experimental implementations of elementary quantum information processing.^{18,26,29,30}

We thank Y. Nakamura, D. Esteve, R. Fazio, and P. Delsing for helpful discussions. This work has been supported by EU IST-FET-SQUBIT and SQUBIT-2, the Swedish Research Council, and the Swedish Foundation for Strategic Research.

-
- ¹Y. Nakamura, Yu. A. Pashkin, and J. S. Tsai, *Nature (London)* **398**, 786 (1999).
- ²I. Chiorescu, Y. Nakamura, C. J. P. M. Harmans, and J. E. Mooij, *Science* **299**, 1869 (2003).
- ³D. Vion, A. Cottet, A. Aassime, P. Joyez, H. Pothier, C. Urbina, D. Esteve, and M. H. Devoret, *Science* **296**, 886 (2002).
- ⁴T. Duty, D. Gunnarsson, K. Bladh, and P. Delsing, *Phys. Rev. B* **69**, 140503(R) (2004).
- ⁵E. Collin, G. Ithier, A. Aassime, P. Joyez, D. Vion, and D. Esteve, *cond-mat/0404503* (unpublished).
- ⁶I. Chiorescu, P. Bertet, K. Semba, Y. Nakamura, C. J. P. M. Harmans, and J. E. Mooij, *Nature (London)* **431**, 159 (2004).
- ⁷A. Wallraff, D. Schuster, A. Blais, L. Frunzio, R.-S. Huang, J. Majer, S. Kumar, S. M. Girvin, and R. J. Schoelkopf, *Nature (London)* **431**, 138 (2004).
- ⁸Yu. A. Pashkin, T. Yamamoto, O. Astafiev, Y. Nakamura, D. V. Averin, and J. S. Tsai, *Nature (London)* **421**, 823 (2003).
- ⁹A. J. Berkley *et al.*, *Science* **300**, 1548 (2003).
- ¹⁰J. B. Majer, F. G. Paaauw, A. ter Haar, C. J. P. M. Harmans, and J. E. Mooij, *cond-mat/0308192* (unpublished).
- ¹¹T. Yamamoto, Yu. A. Pashkin, O. Astafiev, Y. Nakamura, and J. S. Tsai, *Nature (London)* **425**, 941 (2003).
- ¹²A. Izmalkov *et al.*, *Phys. Rev. Lett.* **93**, 037003 (2004).
- ¹³A. Shnirman, G. Schön, and Z. Hermon, *Phys. Rev. Lett.* **79**, 2371 (1997).
- ¹⁴Yu. Makhlin, G. Schön, and A. Shnirman, *Nature (London)* **398**, 786 (1999).
- ¹⁵F. Plastina and G. Falci, *Phys. Rev. B* **67**, 224514 (2003).
- ¹⁶A. Blais, A. Maassen van den Brink, and A. M. Zagoskin, *Phys. Rev. Lett.* **90**, 127901 (2003).
- ¹⁷D. V. Averin, *Solid State Commun.* **105**, 659 (1998).
- ¹⁸J. Siewert and R. Fazio, *Phys. Rev. Lett.* **87**, 257905 (2001).
- ¹⁹J. Q. You, J. S. Tsai, and F. Nori, *Phys. Rev. B* **68**, 024510 (2003).
- ²⁰J. Q. You, J. S. Tsai, and F. Nori, *Phys. Rev. Lett.* **89**, 197902 (2002).
- ²¹D. V. Averin and C. Bruder, *Phys. Rev. Lett.* **91**, 057003 (2003).
- ²²A. Zorin, *Physica C* **368**, 284 (2002).
- ²³I. Siddiqi *et al.*, *cond-mat/0312623* (unpublished).
- ²⁴A. Aassime, G. Johansson, G. Wendin, R. J. Schoelkopf, and P. Delsing, *Phys. Rev. Lett.* **86**, 3376 (2001).
- ²⁵For two qubits, similar controllable coupling can be achieved by applying flux bias (Ref. 19) instead of current bias. However, to be scalable this approach requires complicated circuitry (Ref. 20).
- ²⁶N. Schuch and J. Siewert, *Phys. Rev. Lett.* **91**, 027902 (2003).
- ²⁷U. Weiss, *Quantum Dissipative Systems*, 2nd ed. (World Scientific, Singapore, 1999), Chap. 12.
- ²⁸J. M. Martinis, S. Nam, J. Aumentado, and C. Urbina, *Phys. Rev. Lett.* **89**, 117901 (2002).
- ²⁹R. M. Gingrich, P. Kok, H. Lee, F. Vatan, and J. P. Dowling, *Phys. Rev. Lett.* **91**, 217901 (2003).
- ³⁰G. K. Brennen, D. Song, and C. J. Williams, *Phys. Rev. A* **67**, 050302(R) (2003).