



**CHALMERS**  
UNIVERSITY OF TECHNOLOGY

## **A review of fractional-order techniques applied to lithium-ion batteries, lead-acid batteries, and supercapacitors**

Downloaded from: <https://research.chalmers.se>, 2020-07-11 08:29 UTC

Citation for the original published paper (version of record):

Zou, C., Zhang, L., Hu, X. et al (2018)

A review of fractional-order techniques applied to lithium-ion batteries, lead-acid batteries, and supercapacitors

Journal of Power Sources, 390: 286-296

<http://dx.doi.org/10.1016/j.jpowsour.2018.04.033>

N.B. When citing this work, cite the original published paper.

# A review of fractional-order techniques applied to lithium-ion batteries, lead-acid batteries, and supercapacitors

Changfu Zou<sup>a,\*</sup>, Lei Zhang<sup>b,\*</sup>, Xiaosong Hu<sup>c,\*\*</sup>, Zhenpo Wang<sup>b</sup>, Torsten Wik<sup>a</sup>, Michael Pecht<sup>d</sup>

<sup>a</sup>Department of Electrical Engineering, Chalmers University of Technology, Gothenburg 41296, Sweden

<sup>b</sup>National Engineering Laboratory for Electric Vehicles, Beijing Institute of Technology, Beijing 100081, China

<sup>c</sup>State Key Laboratory of Mechanical Transmissions, Chongqing University, Chongqing 400044, China

<sup>d</sup>Center for Advanced Life Cycle Engineering, University of Maryland, College Park, MD 20742, USA

---

## Abstract

Electrochemical energy storage systems play an important role in diverse applications, such as electrified transportation and integration of renewable energy with the electrical grid. To facilitate model-based management for extracting full system potentials, proper mathematical models are imperative. Due to extra degrees of freedom brought by differentiation derivatives, fractional-order models may be able to better describe the dynamic behaviors of electrochemical systems. This paper provides a critical overview of fractional-order techniques for managing lithium-ion batteries, lead-acid batteries, and supercapacitors. Starting with the basic concepts and technical tools from fractional-order calculus, the modeling principles for these energy systems are presented by identifying disperse dynamic processes and using electrochemical impedance spectroscopy. Available battery/supercapacitor models are comprehensively reviewed, and the advantages of fractional types are discussed. Two case studies demonstrate the accuracy and computational efficiency of fractional-order models. These models offer 15-30% higher accuracy than their integer-order analogues, but have reasonable complexity. Consequently, fractional-order models can be good candidates for the development of advanced battery/supercapacitor management systems. Finally, the main technical challenges facing electrochemical energy storage system modeling, state estimation, and control in the fractional-order domain, as well as future research directions, are highlighted.

*Keywords:* Batteries, electrochemical energy storage systems, energy management, fractional-order models, supercapacitors

---

## 1. Introduction

Transportation electrification and grid integration of renewable energy sources constitute two renewed research efforts to reduce dependence on fossil fuels and mitigate global warming [1]. Market penetration of electrified vehicles (EVs) can help meet these goals if it is coupled with decarbonized electricity, for example, solar and wind power [2]. Electrochemical energy storage systems (EESSs) play a critical role in both EVs and renewable energy integration applications. They serve as energy sources to provide power supply and/or energy buffers to improve efficiency and the overall economy.

Rechargeable batteries and supercapacitors are typical EESSs that share a similar structure—both of them store and convert energy through diffusion and migration of ions. Each battery or supercapacitor cell is composed of positive and negative electrodes separated by an enabling separator that allows ion transfer but prevents electron conduction. Electrodes and their separators are often immersed in an electrolyte solution that contains mobile ionic species [3]. Among a number of

different energy storage technologies, lithium-ion (Li-ion) batteries have currently been accepted as the leading candidate for commercial EESSs because of their superiority, especially in volumetric and gravimetric energy densities [4, 5]. However, each EESS has unique features and characteristics, and may be well suited for particular applications. For example, while lead-acid batteries are primarily used in cases where cost, reliability, and abuse tolerance are crucial [6], supercapacitors are preferred in devices that require high power density and long cycling lifetime [7].

EESSs must be safe and highly tolerant of high/low temperatures. They must also be cost-effective and provide large energy/power density and long cycle life. To pursue these objectives, model-based state estimation/monitoring techniques and energy management schemes have been extensively studied in the literature, e.g., [8, 9]. A common requirement of these tasks is to construct accurate yet simple mathematical models that are adaptable to thermal and aging phenomena inherent in EESSs.

Considerable research efforts have been dedicated to mathematically modeling EESS dynamics and have resulted in physics-based, equivalent circuit, and data-driven models [10, 11, 12]. Based on differentiation orders, these models can generally be assorted into integer- and fractional- order models. Integer-order models dominate the research and engineering application of electrochemical energy storage. Hu et al. [13] compared commonly used equivalent circuit models of Li-ion

---

\*C. Zou and L. Zhang equally contributed to this work.

\*\*Corresponding author.

Email addresses: changfu.zou@chalmers.se (Changfu Zou), lei\_zhang@bit.edu.cn (Lei Zhang), xiaosonghu@ieee.org (Xiaosong Hu)

batteries in terms of accuracy, complexity, and robustness under vehicle driving cycles. Doyle et al. [14] and Zou et al. [15] formulated electrochemical models governed by a set of partial or ordinary differential equations for Li-ion cells. Zhang et al. [16] and Drummond et al. [17] discussed electrochemical models for supercapacitors. However, it has been incrementally recognized, such as by Freeborn et al. [18], that EESSs exhibit some mathematical characteristics in accordance with fractional-order systems. This fact solicits increased interest and endeavors to come up with novel EESS models in the domain of fractional calculus. As a result, the fractional-order modeling methodology may not only improve prediction accuracy but also preserve some physical meanings underlying model parameters.

This paper provides a comprehensive review of fractional-order techniques for typical EESSs, including Li-ion batteries, lead-acid batteries, and supercapacitors. Section 2 presents the mathematical fundamentals of fractional-order calculus. Section 3 introduces the common dynamic processes of EESSs and electrochemical impedance spectroscopy to elucidate the principles of fractional-order modeling. Available battery/supercapacitor models are sequentially surveyed, grouped, and characterized. After analyzing parameter identification techniques in Section 4, the accuracy and computational requirement of fractional-order models (FOMs) are quantitatively investigated via case studies in Section 5. Section 6 highlights the main technical challenges facing FOM-based management for EESSs, including modeling of coupled system dynamics, state estimation, and charge/discharge control, followed by concluding summaries in Section 7.

## 2. Mathematical fundamentals

This section exhibits the mathematical fundamentals of fractional-order calculus (FOC) to facilitate the understanding of concepts and technical tools used for modeling electrochemical energy systems. In particular, the definitions of impedance and fractional-order derivatives and the FOM's state-space representation will be discussed. A thorough exposition of FOC can be found in textbooks on fractional-order system modeling, analysis, and applications [19, 20, 21] and related survey articles [22, 23].

*Frequency-domain electric impedance.* In the frequency domain, a general impedance,  $Z$ , in electrical circuits may be defined by the following proportional relation

$$Z \propto (j\omega)^\alpha, \text{ for } \alpha \in [-1, 1], \omega \in \mathbb{R}, \quad (1)$$

where  $j$  is the imaginary number and  $\omega$  is the radian frequency. The conventional equivalent circuit elements, including pure capacitors, resistors, and inductors, are special cases of  $Z$ , corresponding to  $\alpha = 1, 0$ , and  $-1$ , respectively.

As initially proposed by Cole and Cole [24], a fractional-order capacitive element can be characterized by the impedance in (1) as

$$Z_{\text{CPE}} = \frac{1}{C_\alpha(j\omega)^\alpha}, \text{ for } \alpha \in (0, 1), \quad (2)$$

where the exponent  $\alpha$  is a fractional-order and  $C_\alpha$  is a constant and is called a pseudo-capacitance with the dimension  $\text{F}\cdot\text{sec}^{\alpha-1}$  [25].  $Z_{\text{CPE}}$  has a constant phase angle at  $\alpha\pi/2$  [26] and is often called a constant phase element (CPE). In comparison, the phase shift for pure capacitors is  $\pi/2$ .

*Fractional-order derivatives.* The fractional-order operator for the CPE in (2) is mathematically defined by  ${}_0\mathfrak{D}_t^\alpha(\cdot) = d^\alpha(\cdot)/dt^\alpha$ . An equation with  ${}_0\mathfrak{D}_t^\alpha$  describes dynamic processes with infinite dimension. To facilitate analysis and numerical implementation, three different definitions, namely, Riemann-Liouville (RL), Caputo, and Grünwald-Letnikov (GL) fractional derivatives are often utilized for such an operator [19]. For instance, the GL fractional derivative takes explicitly the form

$${}_0\mathfrak{D}_t^\alpha f(t) = \lim_{T \rightarrow 0} \frac{1}{T^\alpha} \sum_{k=0}^{\lfloor t/T \rfloor} (-1)^k \langle \alpha, k \rangle f(t - kT), \quad (3)$$

where  $T$  is the sampling time interval,  $\lfloor t/T \rfloor$  is the maximum integer lower than  $t/T$ , and  $\langle \alpha, k \rangle$  represents the Newton binomial term defined as

$$\langle \alpha, k \rangle = \frac{\Gamma(\alpha + 1)}{\Gamma(k + 1) \cdot \Gamma(\alpha - k + 1)}, \quad (4)$$

where  $\Gamma(\cdot)$  is the gamma function with the definition of

$$\Gamma(\alpha) = \int_0^\infty \xi^{\alpha-1} e^{-\xi} d\xi. \quad (5)$$

For simplicity,  ${}_0\mathfrak{D}_t^\alpha f(t)$  is written as  $\mathfrak{D}^\alpha f(t)$  in the sequel. A comprehensive description of these definitions as well as their peculiarities has been presented in [19, 27].

Unlike their integer alternatives, fractional derivatives are not local operators because they take into account the entire past trajectory of  $f(\cdot)$  over the interval  $[0, t]$ , as seen in (3). This is the so-called *long memory property* of fractional derivatives. However, this property significantly increases the computational burden for engineering applications of FOMs, particularly for real-time model-based optimization and control. To improve implementation efficiency, a short memory principle was therefore proposed by Podlubny [28] to approximate (3) with high-order difference equations, which consider only recently past information in the state propagation. This approach has been shown to be effective in a number of examples in fractional-order modeling of Li-ion batteries [29] and supercapacitors [30]. Indeed, there is in general a trade-off between modeling accuracy and computational complexity around the memory length.

*System representation and types.* The state-space representation of a general fractional-order system can be written in the following form

$$\mathfrak{D}^\alpha x(t) = f(t, x(t), u(t)), \quad (6a)$$

$$y(t) = h(t, x(t), u(t)), \quad (6b)$$

where  $x := [x_1, \dots, x_n]$  is the state vector,  $\mathfrak{D}^\alpha x := [\mathfrak{D}^{\alpha_1} x_1, \dots, \mathfrak{D}^{\alpha_n} x_n]$ , and  $u, y$  are separately the system input and output vectors. This representation is the same as integer-order

system representations except for the fractional derivative on the left-hand side of (6a). If  $\alpha_1, \dots, \alpha_n$  are all positive integer multiples of a real number  $\gamma$ , then (6) is a commensurate fractional-order system of order  $\gamma$ ; otherwise, it is said to be incommensurate, with more degrees of freedom to fit system dynamics [19, 31, 32].

### 3. EESS modeling

Before reviewing fractional models for different EESSs, the modeling principles are first explained by analyzing system dynamic processes and electrochemical impedance spectroscopy.

#### 3.1. Modeling principles

*Dynamic processes.* A common feature of EESSs is that multiple dynamic processes occur simultaneously during operation and inherently exhibit different time scales. The fastest dynamic process is dedicated to the movement of charge carriers through the electrolyte and current collectors to the external circuit. Along with the decreasing direction of the frequency spectra, there are electrochemical double-layer effects and charge-transfer reactions. This is followed by the solid-phase ion diffusion in batteries and the stray inductance of current collectors and porous electrodes in supercapacitors. All EESSs suffer from persistent, irreversible aging phenomena during static storage or cycling operation, which is the slowest dynamic process. These dynamic processes in general are coupled. For example, the stressed electrochemical reactions expedite system degradation, and in turn, the aging reaction influences charge/discharge performances.

An explicit identification of multiple time scales from Li-ion battery dynamics was conducted in [15, 33]. Therein, techniques based on singular perturbations and the averaging theory were proposed to systematically separate the dynamics. The processes that occur in a typical supercapacitor have also been explained via frequency-domain impedance analysis, e.g., in [34, 35].

*Electrochemical impedance spectroscopy.* Electrochemical impedance spectroscopy (EIS) is a powerful tool to investigate the behavior and properties of EESSs in a non-destructive manner [36, 37, 38]. The principle of EIS analysis is to distinguish the above different physical processes by characterizing the impedance over wide frequency ranges. Specifically, the impedance  $Z$  of an electrochemical system around some steady or quasi-steady state can be determined using the following two-step procedure:

- (i) Apply a sequence of small AC currents, which can be expressed as  $I(t) = |I|e^{j(\omega t + \phi_I)}$  if they are sinusoidal signals, to excite the system and then measure its voltage response,  $V(t) = |V|e^{j(\omega t + \phi_V)}$ .
- (ii) Collect current and voltage data and evaluate the impedance by dividing the voltages by its corresponding currents, namely  $Z = |V|e^{j(\phi_V - \phi_I)} / |I|$ .

The characteristics of the impedance spectra can provide insights into electrochemical systems and then be used to develop mathematical models for predicting system dynamics.

*Equivalent circuit modeling principles.* Equivalent circuit modeling can be motivated by EIS, with the goal to fit experimentally measured impedance data using circuit elements. Lumped resistors, capacitors, inductors, and voltage sources are typical elements used in conventional equivalent circuit models (ECMs) [13, 39, 40]. To improve modeling fidelity, a CPE was proposed in [24] with the mathematical definition given by (2). With CPEs, the plate hypothesis underlying the real electrodes can be relaxed, and non-uniform boundary and distributed intercalation/de-intercalation processes within porous electrodes can be described. The obtained models incorporating one or more CPEs are often referred to as FOMs, which have been used to mimic dynamic behaviors of EESSs [41, 42, 29].

In the context of circuit approaches, the development of FOMs for a battery or supercapacitor, in essence, consists of selecting CPEs together with other circuit elements and then appropriately organizing them in a circuit. Usually, there are some modeling criteria, depending on specific applications, such as accuracy and complexity. Different techniques available for Li-ion batteries, lead-acid batteries, and supercapacitors are surveyed in the following subsections.

#### 3.2. Lithium-ion battery models

Li-ion batteries were first commercially developed by Sony in the early 1990s and have experienced remarkable advances over recent years [6, 43]. Their prosperity is largely driven by demands for portable electronic devices, smart grids, and EVs. With continuous performance improvements and cost reductions, the deployment of Li-ion batteries is predicted to increase rapidly in the near future [44] and thus is primed to dominate the energy storage market.

Li-ion batteries, with a cost of US\$250 per kilowatt-hour [45] and energy efficiency at 200-250 watt-hours per kilogram [46], however, are expensive compared to fossil fuels like petrol and diesel. In addition, battery state of health (SoH), reliability, and safety are critical concerns that need to be addressed over a battery's entire lifespan. A battery management system (BMS) can deal with these economic and performance concerns because it synthesizes from hardware and software to monitor, control, and diagnose the battery pack and individual cells [10, 12]. Explicitly, its functionality may involve state estimation, thermal management, charge/discharge control [47], and cell balancing [48]. To realize these functions, an important first step is to establish reliable and numerically efficient battery models.

For a typical Li-ion cell, the Nyquist plot of its impedance spectrum is illustrated in Fig. 1. The impedance spectrum can be divided into three sections according to frequency. The high-frequency tail is typically interpreted as the ohmic resistance of inductive components, such as current collectors and test cables. The low-frequency straight line is mainly invoked by electrochemical double-layer and charge-transfer reactions. This can be captured by a CPE, usually referred to as a Warburg element. The mid-frequency semi-ellipse stems from lithium diffusion within solid electrodes and can potentially be modeled by some tandem fractional-order networks, each of which is constituted by a CPE in parallel with a resistor [38].

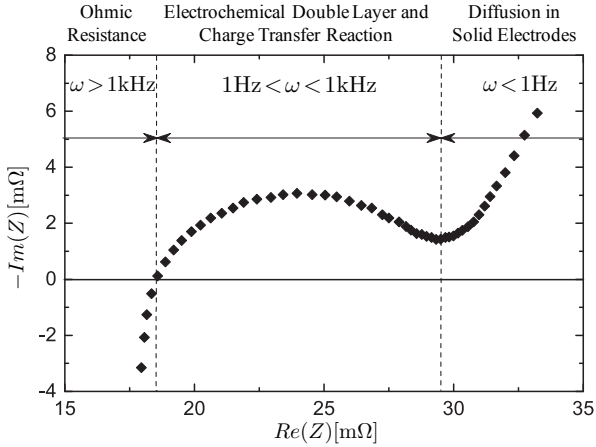

Figure 1: Nyquist plot of impedance spectrum measured from a typical Li-ion cell (modified from [49]).

The phase shift of a fractional-order capacitor,  $\alpha\pi/2$ , is called a *phasance*, a term introduced by Jean [26]. The phasance is an important characteristic parameter of the Nyquist plot in Fig. 1. In particular, the phasance of a Warburg element represents the slope of the low-frequency straight line, while for a CPE-resistor network, it is related to the shape of the depressed semicircle. In contrast, the phasance of pure capacitors is fixed to be  $\pi/2$ , which cannot well capture the Nyquist plot's characteristics. A thorough explanation of the phasance concept and mathematics behind it can be found in [26].

In integer-order models (IOMs) of Li-ion batteries, CPEs are either approximated by ideal capacitors [50], or a number of resistor-capacitor (RC) networks [13, 51], or relaxation times [52]. The first option, as exemplified in Fig. 2(a), is extensively applied to battery management due to the simplicity in its parameterization and implementation. The resulting models may capture a battery's behavior to a moderate degree of accuracy within a limited range of operating conditions [53]. However, they are commonly not capable of predicting battery dynamics in both the time and frequency domains over the entire operating range. For the latter approaches shown in Fig. 2(b), in general, a greater number of RC networks are required for wider frequency bands. Specifically, the first-order RC model tries to mimic ohmic resistance and charge-transfer reactions, corresponding to the high-frequency tail and **mid-frequency range**, but does not describe the diffusion behavior in the **low-frequency straight line**. For the second-order RC model, the ohmic resistance and diffusion behavior can be simulated, but **the characteristic frequency of the charge-transfer process corresponding to the maximum imaginary part of the impedance cannot be considered** [54]. With the third or higher order RC models, all three processes can be produced. However, these models have a large set of parameters. This not only complicates the model mathematical structure associated with computational burden, but also increases the efforts for system calibration and the risk of over-fitting. In addition, as Westerhoff et al. [54] demonstrated, even though five RC networks are utilized, the IOMs cannot capture the phase at zero very accu-

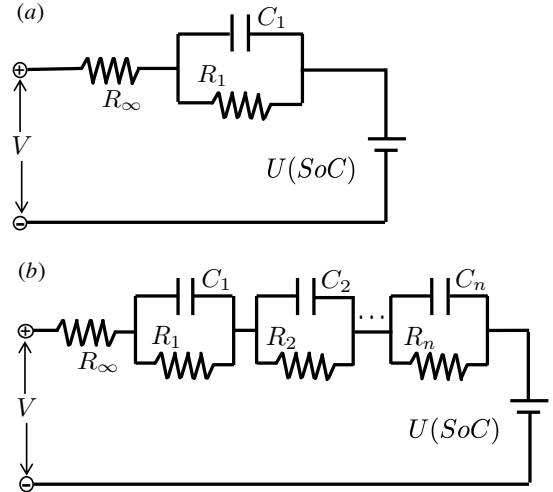

Figure 2: Integer-order equivalent circuit models with different orders.

rately.

*Fractional-order electrical models.* To address the above problems, fractional calculus has recently been explored for Li-ion battery applications. By simply replacing the ideal capacitor in the first-order RC model to a fractional element, an infinite-dimensional model was developed for Li-ion cells in [55]. The obtained FOM is presented in Fig. 3(a). To facilitate numerical calculation, these authors adopted the Oustaloup recursive approximation from [56] to transfer the fractional equations to ordinary difference equations. In this approximation, the lower and upper frequency bounds will impact poles and zeros of the model's transfer function, and then affect the model's accuracy [57]. By using experimental data from time and frequency domains, Alavi et al. [49] found that this model can reproduce a Li-ion battery's behavior better than its integer counterpart, thanks to an additional degree of freedom, namely the fractionation order. Waag et al. [58] utilized this model to describe the current-voltage response at dynamic loads measured from EVs. Therein, the FOM with one CPE was found to be equivalent to an IOM with five RC networks. To achieve higher accuracy, Wang et al. [59] presented an FOM by adding a Warburg element ( $W$ ) in series with the charge-transfer resistor ( $R_1$ ) (see Fig. 3(b)). By using the GL fractional derivative, this FOM has demonstrated a high fidelity to experimental data. Liao et al. [60] exploited this model to study the electrochemical behavior of a lithium iron phosphate/hard carbon cell. With the same circuit elements but a different structure, the model shown in Fig. 3(c) was used by Xu et al. [29] to describe Li-ion battery dynamics. The model presented in Fig. 3(d) with two CPEs has also been employed, e.g., in [61], and is expected to be more robust to uncertainties.

All the above works tend to confirm that the fractional modeling approach is capable of accurately predicting Li-ion cell electrical dynamics. Consequently, these models have attracted increased interest in model-based battery management. Xu et al. [29] synthesized an FOM and fractional Kalman filter to estimate the state of charge of a Li-ion battery. Zou et al. [62] pro-

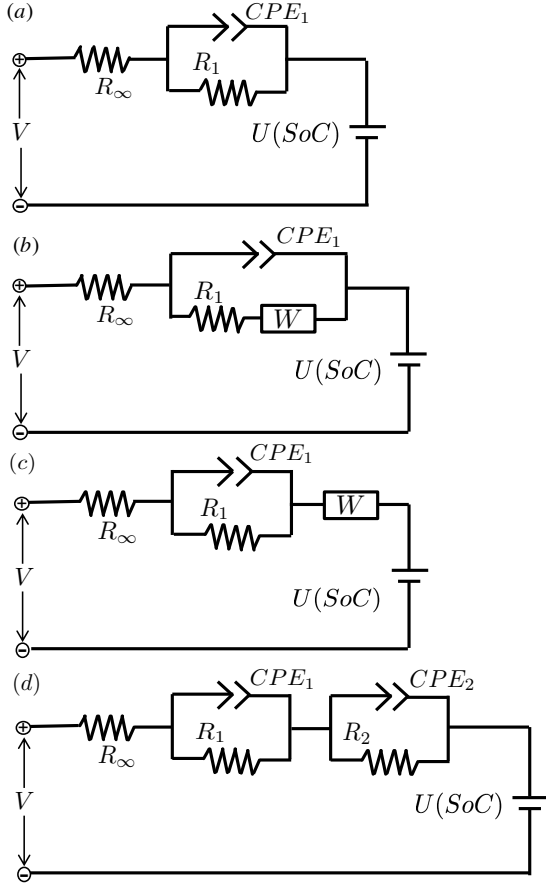

Figure 3: Typical fractional-order circuit models for a Li-ion cell.

posed a nonlinear fractional estimation algorithm with provable stability and robustness and then applied it to monitor battery states. Other algorithms for Li-ion battery applications based on fractional electrical models can be found in [63, 64, 65] and references therein.

*Fractional-order physics-based models.* Alternatively to equivalent circuit models, Li-ion battery models can be established from first principles that describe electrochemical reactions and the Li-ion intercalation/de-intercalation process. The initial electrochemical model for a Li-ion cell was proposed by Doyle et al. [14] using concentrated solution theory. This model was extended by Zou et al. [15, 66] to incorporate electrical, thermal, and aging dynamics, and was constituted by a number of coupled nonlinear partial differential equations (PDEs). These authors then reformulated this complete battery model in a Hilbert space to precisely characterize its mathematical structure. As a result, the singularly perturbed structure underlying the battery model is uncovered. This enables the use of available singular perturbation theory for timescale separation of battery dynamics, leading to a family of simplified PDE models.

However, because the obtained PDE-based models are still too computationally expensive for real-time implementation, here is an incentive to perform model-order reductions. Sabatier et al. [67] proposed a fractional electrochemical model

by simplifying a PDE-based electrochemical model. Starting from this model, Sabatier et al. [68] developed a fractional single electrode model by gradually introducing assumptions on battery physical and chemical properties. Alternatively, according to Li et al. [69], a simplified physics-based model can be established with fractional-order transfer functions to describe solid-phase lithium diffusion. In addition, Li et al. [70] presented an electrochemistry-based impedance model to describe lithium diffusion in the electrodes, charge-transfer reactions at the solid-electrolyte interphase (SEI), double-layer effects, and resistance/capacitance changes associated with the anode SEI film growth. In such a model, electrical elements are used to mimic these internal electrochemical processes, so that their interactions with external current/voltage measurements can be easily understood.

The above simplified models have several intriguing attributes. They largely mitigate the computational burden commonly upon high-order physics-based models, but still capture the key battery characteristics. Furthermore, equipped with fractional-order differentiation, the models contain only a few parameters that have the potential to maintain physical meanings [70, 71]. Indeed, physically meaningful parameters are helpful for various model-based applications, such as in SoH estimation, lifetime prediction, and optimal fast charging control.

*Fractional-order thermal models.* Temperature plays an influential role in a battery's dynamic performance and SoH [72, 73], and effectively modeling the thermal behavior can facilitate advanced temperature management. On the basis of model-based control algorithms, the temperature can be manipulated in a proper range to ensure safe and efficient utilization. The available models are often built on a lumped-parameter energy balance, in which the cell temperature is assumed to be spatially uniform [74, 75]. However, when the heat convection at the cell surface is faster than the heat conduction inside, the established model can appreciably deviate from its real battery system. Aoki et al. [76] proposed a general fractional-order model to approximate transient temperatures. Reyes-Marambio et al. [77] then introduced this idea to model air-cooled cylindrical Li-ion batteries. This model has demonstrated a high predictive capability against experimental results and is intended to be used in thermal control strategy design of battery cells and modules.

### 3.3. Lead-acid battery models

Lead-acid batteries, invented in 1859, have matured to be the most extensively used rechargeable battery technology. Their low cost and high reliability [78] make them competent in large-scale applications, such as uninterrupted power supply and power quality regulation.

Similarly to Li-ion batteries, fractional-order modeling has also seen considerable applications in lead-acid batteries and demonstrated attractive modeling performance. Garcia et al. [79] presented a diffusive model to delineate the dynamic behaviors of lead-acid batteries using a fractional-order operator. Following this, Lin et al. [80] proposed a framework of fractional-order modeling for diffuse processes, which was

then used to simulate the dynamics of lead-acid batteries. The output-error technique was employed by them to derive the model parameters based on classical input/output data of test cells. To characterize the crankability of lead-acid batteries, Sabatier et al. [81] and Cugnet et al. [82] introduced simplified fractional-order models on the basis of conventional ECMs. These models are capable of capturing battery dynamics at a frequency range of 8-30 Hz in which batteries typically operate for engine cranking.

### 3.4. Supercapacitor models

Supercapacitors have emerged as a promising energy storage source particularly suitable for storing and supplying high energy in short periods of time, for instance, in vehicle acceleration and regenerative braking conditions [7]. This phenomenon is functionally attributed to their advantageous performance, such as large power density, high temperature tolerance, and excellent cyclability [11]. Fundamentally, these merits stem from the highly reversible ions adoption mechanism that is non-faradaic and void of ions diffusion in the bulk of the high-conductivity electrodes. Nevertheless, the poor energy density constitutes the main bottleneck for applicability and has been the focus of intensive research. In the past decade, substantial progress has been made to improve the performance of supercapacitors through continuous investigation of efficient storage mechanisms and potentially enhanced electrode and electrolyte materials. Nowadays, cost-effective and reliable supercapacitors with an energy density up to 10 Wh/kg are commercially available [83]. In practice, supercapacitors can complement and even substitute for some high-energy EESSs (e.g., rechargeable batteries) for power sinking and sourcing. In cell design, ongoing research and development are mainly directed towards increasing the energy density, which is now approximately 1/30-1/20 the energy density of state-of-the-art Li-ion batteries [84], and towards further lowering the cost.

An efficient management system is often required to measure, monitor, and control supercapacitor systems that are usually composed of a number of individual cells in series-parallel connections. The management system's functionality includes but is not limited to cell balance, state estimation, safety supervision, and fault detection and isolation. To realize these functions, the fundamental step is to build reliable and accurate models. Many mathematical models for supercapacitors have been presented to simulate the system behaviors. These can be roughly sorted into three categories: integer-order electrochemical models, conventional ECMs, and fractional ECMs.

The initial electrochemical models describe a supercapacitor's internal electrochemical reactions based on first principles. This modeling methodology and its application for supercapacitor management are still an active research topic. These models retain a high model precision but suffer from a heavy computational burden caused by coupled PDEs [17, 85]. Furthermore, parameterization of high-order electrochemical models is technically challenging due to potential identifiability issues and persistent system aging phenomena. Conventional ECMs employ basic electrical circuit elements to represent the supercapacitor dynamics, with varied modeling performance, depend-

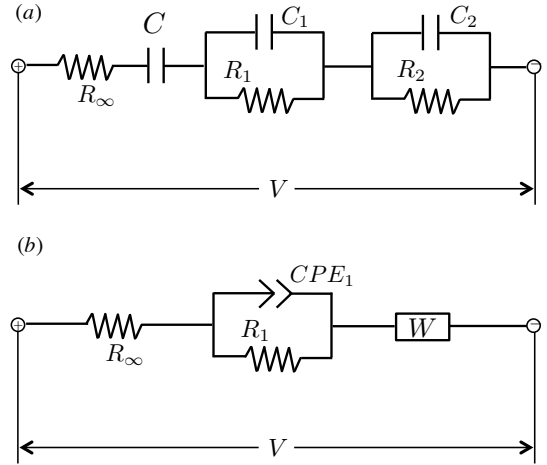

Figure 4: Integer- and fractional-order electrical circuit models for a supercapacitor cell.

ing on circuit topologies. See Fig. 4(a) for a popular example of conventional ECMs for a supercapacitor cell.

Fractional ECMs incorporate circuit elements, such as Warburg elements and fractional-order capacitors shown in Fig. 4(b), to delineate the electrical response of supercapacitors. Using the same principle as Li-ion batteries, fractional supercapacitor models armed with electrical elements at the phasance of  $\alpha\pi/2$  often are better able to fit experimental data using a few parameters, in contrast to their integral-order counterparts. This may efficiently ease the computation intensity and render online implementation of model-based algorithms applicable. For example, Riu et al. [86] introduced a half-order supercapacitor model and demonstrated high accuracy in representing the system dynamics. In addition, Martynuk and Ortigueira [87] utilized a least-squares fitting method to extract parameters of a fractional-order model based on impedance data. Bertrand et al. [88] and [89] synthesized a fractional-order nonlinear model on the basis of frequency analysis. In a similar fashion, Martín et al. [90] proposed a Havriliak-Negami function-based model that is able to predict a supercapacitor's static and dynamical behaviors throughout the spectrum.

## 4. System identification

The usefulness of mathematical models for EESSs highly relies on their parameters. Therefore, parameter identification is a prerequisite to performing model-based simulation, estimation, and control algorithms. The identification of a general fractional-order system was initially conducted by Le Lay in his Ph.D thesis [91]. However, for general nonlinear-in-the-parameters FOMs, no formal identification algorithms can provide provable convergence. To determine which parameters are identifiable for given external excitations, Zhou et al. [92] conducted a sensitivity analysis for equivalent circuit component coefficients and fractional-order values. Most of the subsequent approaches are dedicated to generalizing standard methods, which are used in integer-order systems, to fractional-

order systems. These can be classified into time-domain and frequency-domain methods.

Least-squares (LSQ) estimation techniques have been widely used to identify fractional-order systems in the frequency domain. For example, an output-error identification algorithm based on LSQ was introduced for an inverse heat conduction problem [93]. Sabatier et al. [94] adopted this approach to estimate internal states of lead-acid batteries and then demonstrated its effectiveness in a laboratory environment, where measurements are usually less noisy than real-world applications. Although it is possible to artificially generate broadband noises, data measured in the time domain needs to be converted to the frequency domain using Fourier transforms. However, this process will inevitably result in biased measurements than can degrade estimation accuracy.

It is therefore preferred to identify FOMs directly from time-domain measurements. Recently, this research topic has attracted considerable interest. Before identification of a fractional Li-ion cell model, Zhou et al. [92] adopted a statistical, multi-parametric method to analyze each parameter's sensitivity. Global optimizers, such as genetic algorithm and particle swarm optimization, have been exploited to calibrate fractional nonlinear battery models in [62, 59] and fractional nonlinear supercapacitor models in [30]. To estimate the orders and parameters in an incommensurate fractional-order chaotic system, Zhu et al. [95] proposed a switching differential evolution scheme, where the switching population size is adjusted dynamically. Motivated by this proposal, Lai et al. [96] employed a sequential parameter identification method for a fractional-order Duffing system based on a differential evolution scheme. These authors then demonstrated an improved convergence of the proposed algorithm via numerical implementation. To provide guaranteed error convergence for parameter estimates in finite time, Liu et al. [97] extended a modulating function method for online identification of general linear fractional-order systems. What is interesting with this approach is that it does not require initial conditions and fractional derivatives of the output.

To improve the robustness against measurement noise, Victor et al. [98] developed the instrumental variable state variable filter (IVSVF) and its simplified version for unbiased estimation of fractional-order systems. These methodologies have been successfully applied to solve related problems in the field of EESSs. Alavi et al. [49] combined Victor's IVSVF method and a gradient-based optimization to identify parameters of electrochemical impedance models. Allafi et al. [99] applied a simplified refined IVSVF to identify a fractional transfer function (FTF) model of a Li-ion battery. In contrast to the instrumental variable method, Jacob et al. [100] recently proposed a Bayesian approach to identify the parameters of generic fractional-order systems and then applied this approach to battery models.

In addition to the employed technical methods, the identification results can be affected by various factors such as input signal and measurement noise. Dzieliński et al. [101] proposed a fractional-order model for supercapacitors and parameterized it using time-domain data collected through a constant-current charging test. Freeborn et al. [102] calculated the impedance

parameters of a fractional-order supercapacitor model by the voltage step response. Nonetheless, the model precision may be significantly curtailed when exposed to real-time loading conditions, where the current direction, temperature, and SoC can change rapidly, leading to parameter variations. To address this, Gabano et al. [103] used a cubic spline interpolation technique to derive a fractional continuous linear-parameter-varying model based on locally identified linear-time-invariant fractional impedance models. According to Jacob et al. [100], the memory capability could affect the performance of parameter identification for FOMs, as demanding computation is required by their non-Markovian model setting. These authors also investigated the effects of data length, magnitude of input signals, parameter initialization, and measurement noise on identifying a non-commensurate fractional-order battery model.

All the above approaches aim to address the identifiability problem practically, accounting for information such as noise, bias, and signal quality. As a different concept, structural identifiability is a tool to study the identifiability of model parameters without data. In other words, the input/output data is assumed to be sufficiently rich. Based on this, Alavi et al. [104] performed a structural identifiability analysis for both commensurate and non-commensurate models based on the concept of coefficient maps. After applying the theoretical result to battery systems, they then could prove that fractional circuit battery models with finite numbers of CPEs are structurally identifiable. These results provide fundamental insights and can guide the design and implementation of practical identifiability algorithms.

## 5. Quantitative evaluation of model complexity and accuracy

As discussed in the previous sections, the high-order electrochemical models and conventional circuit models are more or less restricted by their particular attributes and, consequently, may not be the most suitable options for the next-generation management systems of EESSs. In contrast, the fractional modeling approach is very appealing because FOMs are structurally simpler and computationally cheaper than the original electrochemical models and can be more accurate than conventional circuit models. In addition to these general comments, a quantitative evaluation of FOM performance under different operating conditions is preferred. This section investigates FOMs via two case studies, with a special focus placed on model accuracy and computational efficiency.

### 5.1. Case study 1 – battery models

The effectiveness of fractional-order modeling techniques is first examined on battery cells. The model in Fig. 3(a) is exemplified for this purpose and its governing equations are presented in (A.1)-(A.3), where the  $CPE_1$  is subject to fractional order of  $\gamma$ . The GL definition is implemented for fractional derivatives with the memory length limited to 5. As benchmarks, the first-, second-, and third-order RC models from Fig. 2 were also studied and denoted as IOM1, IOM2, and IOM3,



Table 1: Parameters for Li-ion battery models.

Parameters	$R_\infty$	$R_1$	$C_1$	$\gamma$	$R_2$	$C_2$	$R_3$	$C_3$
IOM1	0.1062	0.0523	443.8	–	–	–	–	–
IOM2	0.1025	0.0273	613.2	–	0.0154	3796.6	–	–
IOM3	0.1037	0.0120	907.9	–	0.0158	2935.4	0.0168	2188.8
FOM	0.0966	0.2047	377.3	0.8313	–	–	–	–

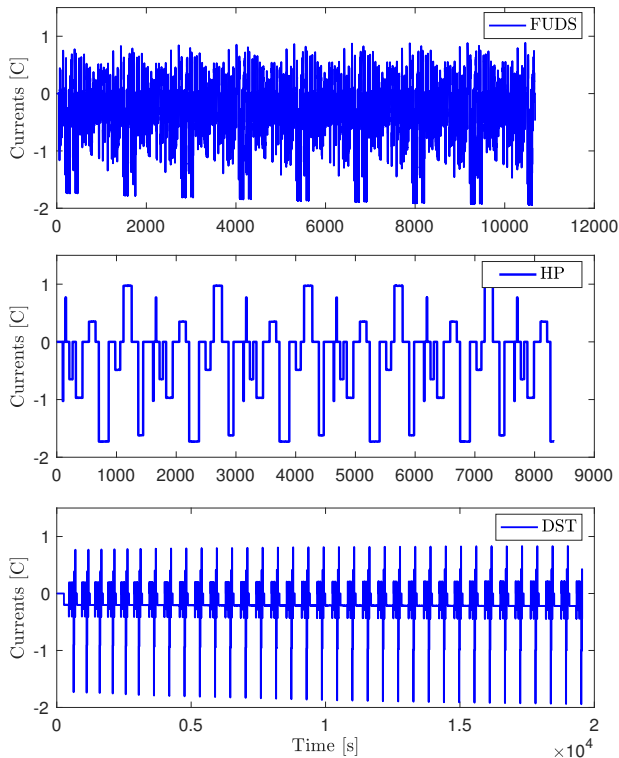

Figure 5: Current signals to test Li-ion battery models.

respectively. Experiments are conducted on a lithium nickel-manganese-cobalt oxide (LiNMC) cell in the type of cylindrical 18650 with a rated capacity of 0.9264 ampere-hours (Ah). The current signals were adopted from dynamic stress test (DST), hybrid pulse (HP) test, and Federal Urban Driving Schedule (FUDS) test, as plotted in Fig. 5. These battery models were calibrated using the corresponding voltage measurements under the FUDS test and then validated against the other two tests.

The parameters to be identified include resistance, capacitance, differentiation order, and the open-circuit voltage (OCV) curve for different models. In particular, the OCV curve is mod-

Table 2: RMS errors [mV] in identification and validation of Li-ion battery models using experimental data.

Models	FUDS	HP	DST
IOM1	7.66	14.81	13.79
IOM2	7.33	10.2	12.32
IOM3	6.15	9.04	12.10
FOM	5.82	9.86	11.71

eled as a fourth-order polynomial function, according to the observation in [105]. Then, a constrained nonlinear optimization problem can be formulated with the objective to minimize the difference between measurements and model predicted voltages. To approach the globally optimal solution, optimization problems are implemented for multiple times with various sets of initial conditions. The obtained solutions from particle swarm optimization for different models of the considered battery cell are given in Table 1. For model fidelity assessment, the root-mean-square (RMS) error and percentage relative error in predicting the terminal voltages are adopted. In particular, the percentage error is defined as

$$\text{Percentage Error}(k) := \frac{V_{\text{mod}}(k) - V_{\text{exprt}}(k)}{\max\{V_{\text{exprt}}(k)\}} \times 100 \quad (7)$$

where  $k \in \{1, 2, \dots\}$ ,  $V_{\text{mod}}$  is the terminal voltage from battery models, and  $V_{\text{exprt}}$  is the voltage measurement.

The FOM and its integer alternatives are first compared in terms of their capability in predicting battery voltage behaviors. The evolution profiles of voltage and modeling error are depicted in Fig. 6. The FOM follows its true voltage trajectories better than IOM1 and IOM2 under both the HP and DST tests. It can also be found that IOM1 cannot well match the measured data, particularly when large currents are applied. This simulation result is consistent with the analysis in Section 3.2. Namely, the first-order RC model is unable to accurately describe lithium diffusion dynamics. The identification and modeling errors for different models are presented in Table 2. Compared with IOM1, FOM can improve the modeling accuracy by 33.4% and 15.1% under the HP and DST tests, respectively. At the same time, it outperforms IOM2 under both tests. Furthermore, under the DST condition, FOM has even better results than IOM3 but with fewer parameters.

However, the high accuracy of the fractional-order modeling approach is brought about at some sacrifice of computational efficiency. Simulations of the three models with the same specifications, in terms of input signal and sampling time, were conducted in a MATLAB m-file environment. While the FOM takes 1.6 microseconds ( $\mu\text{s}$ ) on average to implement one sampling step, the two IOMs take less than 0.3  $\mu\text{s}$ . Such a computational requirement from the FOM may or may not be an issue for real-time model-based algorithms, depending on the battery applications.

It is worth mentioning that the obtained characteristic data on accuracy and computation can be influenced by factors such as the definition of fractional-order derivative, memory length, and operating conditions. Other related studies of either model complexity or computational efficiency have been conducted in

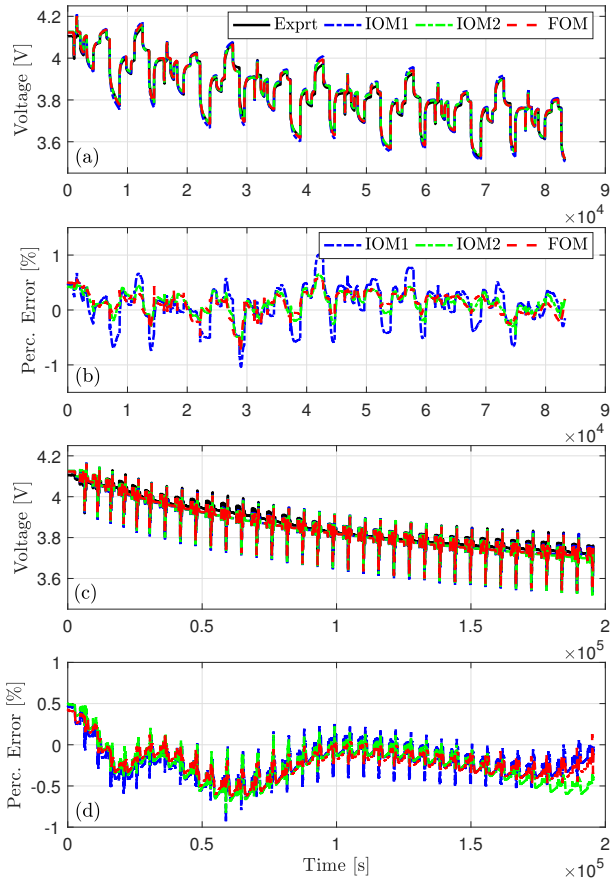

Figure 6: Comparison results of different models for a Li-ion battery against experimental data. (a) and (b) are voltage profiles and percentage errors under the HP test. (c) and (d) are results under the DST test.

[49, 55, 59, 106], where similar conclusions were obtained.

## 5.2. Case study 2 – Supercapacitor

The performance of fractional-order techniques is also evaluated on supercapacitor cells with a nominal capacity of 3000 F and a rated voltage of 2.7 V. The model in Fig. 4(b) with dynamic equations (A.4)-(A.7) is used here to demonstrate the idea. A widely used dynamic model, as in Fig. 4(a) (see [107] for its explicit formulation), is considered as a modeling benchmark. As the same as Section 5.1, the FUDS profile from is adapted here to excite supercapacitors for generating a dataset for model parameterization and the DST test is used for model validation. After scaling, the corresponding current signals applied to the supercapacitors are illustrated in Fig. 7. All the operations are carried out within a thermal chamber with the temperature fixed at 0, 20, and 40 °C, respectively. By deploying the genetic algorithm to globally minimize the squared model-plant error, the FOM and IOM can be parameterized. Parameter identification results corresponding to 20°C are given in Table 3.

An EIS test was performed under a wide range of frequencies, varying from 0.1Hz to 100Hz. Note that this covers most working conditions of supercapacitor energy storage systems. For a comprehensive description of the experimental setup,

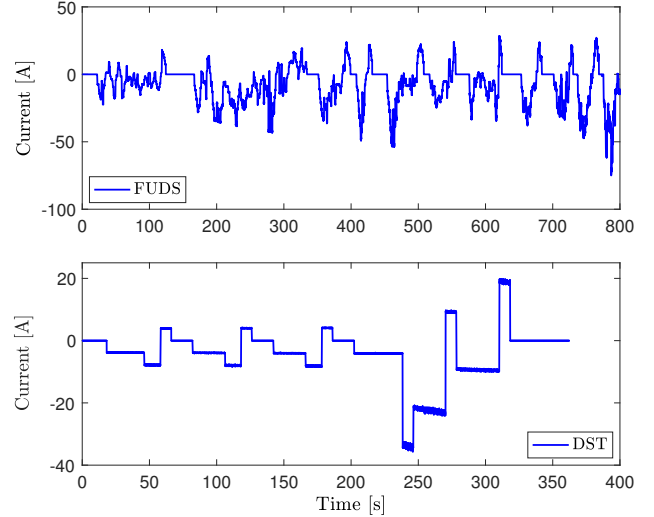

Figure 7: Current signals to test supercapacitor models.

readers are referred to our previous work [34]. Comparison results of both models against the EIS dataset are presented in Fig. 8.

In general, the FOM is able to describe the supercapacitor impedance better than its integer-order comparative, across the considered spectrum and over different temperatures. Such superiority becomes more apparent at reduced temperatures and low frequencies. The reasons are mainly twofold: the IOM cannot well capture the mass transfer effect at low temperatures; the charge-transfer polarization voltage is extremely small at high frequencies but significantly increases as the frequency decreases [108].

Quantitatively, the RMS errors are calculated to differentiate the modeling performance of the FOM and IOM. The FOM has an RMS error of 0.084 Ω for the above tests, in comparison with an RMS error of 0.105 Ω for the IOM. That is, the FOM-based technique offers a 20% rise in accuracy. Indeed, this advantage may vary for different test protocols and with different numerical specifications in implementing the fractional derivatives. For example, the modeling accuracy of FOMs can in general be improved at a large memory length. However, systematically investigating their effects is beyond the scope of this review work. The advantages of FOM over IOM for supercapacitors have also been demonstrated and confirmed in other publications, such as [109, 110].

## 6. Challenges and future prospects

Despite the advances in fractional modeling techniques, the deployment of intelligent management algorithms of EESSs based on FOMs still faces a number of technical challenges. Intensive studies on fractional modeling methodologies and model-based applications are mainly required in the following areas:

*System modeling.* Fractional-order electrical models and thermal models have been individually established for batteries and supercapacitors. However, electrical and thermal dy-

Table 3: Parameters for supercapacitor models.

FOM	$R_\infty$	$R_1$	$C_1$	$W$	$\gamma$	$\beta$
	$3.0 \times 10^{-4}$	$8.6 \times 10^{-5}$	854	2880	0.971	0.975
IOM	$R_\infty$	$R_1$	$C_1$	$C$	$R_2$	$C_2$
	$2.68 \times 10^{-4}$	$8.69 \times 10^{-5}$	1095	2959	$3.7 \times 10^{-5}$	60.68

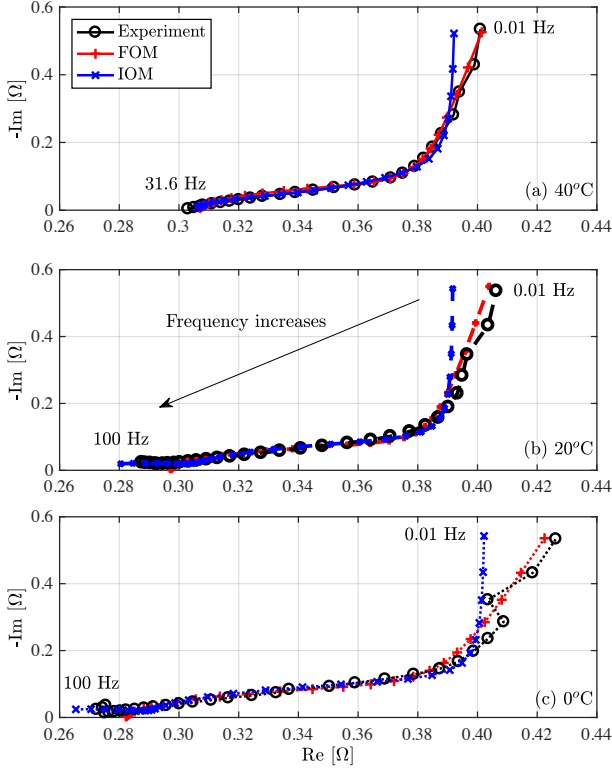

Figure 8: Comparison of different supercapacitor models using electrochemical impedance spectroscopy.

ynamics intrinsically interact with each other in these electrochemical systems [111, 112]. Thus, the coupling relationships between these dynamic processes are necessary to model. Furthermore, common to different EESSs is that the capacity and power supply ability, which are often used to quantify the SoH, will inevitably experience an aging process. Such a process can be accelerated dramatically if EESSs operate under inappropriate conditions [113]. The importance of SoH management becomes crucial for safety-critical and cost-sensitive applications. Fractional-order modeling for the aging phenomena can be an important step to effectively protect an EESS's health and prolong its lifetime. The last but not the least step is the model's adaptivity. The available FOMs of batteries/supercapacitors are usually parameterized once and then are expected to play a role over the whole lifespan. As observed from [62, 61], in this case, the models will mismatch their true system incrementally and fail at some stage. Therefore, adaptive FOMs need to be developed in which model parameters can accommodate the effects of system aging, ambient temperature, and SoC levels.

*State estimation.* SoC, SoH, state of energy (SoE), and state of power (SoP) are the most important indicators of EESS internal states. Accurate knowledge of these states is required in the pursuit of various objectives, for example, to ensure charge/discharge safety, to satisfy end-user demands, to improve convenience, and to execute system-level energy management. However, these states cannot be measured directly during on-board application using currently available sensing techniques. This fact fundamentally motivates observer designs based on measurements such as current, voltage, and cell surface temperature. A considerable number of integer-order estimation algorithms have been proposed to probe state/parameter behavior inside EESSs, such as Luenberger observers and Kalman filters. By extending these estimation approaches to FOMs, some initial work has recently been attempted to estimate the SoC of Li-ion cells [65, 114] and of supercapacitors [30]. In 2017, Li et al. [115] applied an adaptive fractional-order extended Kalman filter to the SoE estimation for Li-ion batteries in EVs. In the context of lead-acid batteries, Cugnet et al. [82] pioneered a fractional resistance-estimator to indicate its crankability in starting a vehicle. Monitoring SoH and SoP in real time based on FOMs is crucial for safe and optimal utilization of EESSs but has not been comprehensively and systematically studied yet. Meanwhile, given that several processes occur simultaneously in EESSs with different time constants, it would be desirable to have some dual fractional estimation algorithms in which the states could be estimated in separate time scales. In addition, both the accuracy and resiliency need to be addressed in the presence of a range of uncertainties inherent in EESSs.

*Charge/discharge control.* The cycling operation of EESSs should be meticulously managed. Electrical energy and power need to be delivered effectively and efficiently, and at the same time, users' requirements in charging time, vehicle transient acceleration, SoH, and/or the overall economy must be taken into account. Usually, some or all of these factors are important yet compete with each other. Multi-objective control problems may need to be considered to maintain an optimal trade-off among the selected objectives during the charge/discharge process, such as health-aware fast charging and aging-adaptive optimal energy management. To do so, in-situ dynamic information for EESSs and its prediction into some future time interval from the FOMs can be critical.

Fractional automatic control can be explained as the reason that gives rise to a renewed interest in FOMs. In comparison to integer-order proportional-integral-derivative (PID) controllers, fractional-order PID controllers have more tuning parameters within the embedded optimization algorithms and thus are able to achieve superior convergence and robustness

properties [116, 117]. The methodologies including CRONE (Commande Robuste d'Ordre Non Entier),  $H_\infty$ , and flatness control have been exhaustively reviewed in [27]. According to [118, 119], fractional calculus can also be integrated into sliding mode control (SMC) to obtain better performance. These fractional control theories and applications in other areas may form a powerful tool to enhance EESSs' dynamic performance and extend the working life.

## 7. Conclusions

This paper provided an overview of the current development in mathematical models for lithium-ion batteries, lead-acid batteries, and supercapacitors, with a particular focus on fractional-order techniques. The review has illustrated the links between fractional-order calculus, electrochemical impedance spectroscopy, and EESS dynamic characteristics. By surveying various available battery and supercapacitor applications, fractional-order models (FOMs) are shown to have been widely studied, with attempts to capture system electrical, electrochemical, and thermal dynamics. Such modeling mechanisms are capable of predicting system behaviors and have the potential to maintain physically meaningful parameters. The advantages of model precision associated with computational complexity were further confirmed in this work via numerical case studies on lithium-ion battery and supercapacitor cells. To enable model usage, parameter identification techniques for FOMs were discussed, and the benefits of using time-domain measurements, instead of frequency-domain data, were presented.

To enable further advances in battery and supercapacitor management, a research outlook for fractional modeling methodology and model-based applications has been discussed. The research directions mainly include (1) the development of system models that describe coupled electrochemical-thermal dynamics and are adaptive to factors such as system aging and time-varying ambient conditions, (2) the design of estimation algorithms to observe SoC, SoE, SoP, and SoH in real-time, and (3) the adoption of FOM-based controllers to improve charge and discharge performance.

## Appendix A. Fractional-order battery/supercapacitor models

Governing equations of the Li-ion battery model in Fig. 3(a) can be formulated based on Kirchhoff's current and voltage laws:

$$\mathfrak{D}^1 SoC(t) = \frac{\eta \cdot I(t)}{3600C_n} \quad (\text{A.1})$$

$$\mathfrak{D}^\gamma V_1(t) = -\frac{V_1(t)}{R_1 C_1} + \frac{I(t)}{C_1} \quad (\text{A.2})$$

$$V(t) = U(SoC(t)) + R_\infty I(t) + V_1(t). \quad (\text{A.3})$$

Similarly, governing equations of the supercapacitor model in Fig. 4(b) can be established:

$$\mathfrak{D}^1 SoC(t) = \frac{\eta \cdot I(t)}{3600C_n} \quad (\text{A.4})$$

$$\mathfrak{D}^\gamma V_1(t) = -\frac{V_1(t)}{R_1 C_1} + \frac{I(t)}{C_1} \quad (\text{A.5})$$

$$\mathfrak{D}^\beta V_2(t) = \frac{I(t)}{W} \quad (\text{A.6})$$

$$V(t) = R_\infty I(t) + V_1(t) + V_2(t) \quad (\text{A.7})$$

In the above two models,  $C_n$  is the nominal capacity in Ah and  $\eta$  is the coulombic efficiency.

## Acknowledgements

This work of C. Zou and T. Wik was supported in part by the Swedish Energy Agency under the Grant No. 39786-1. This work of X. Hu was supported in part by Fundamental Research Funds for the Central Universities, China (Project No.106112017CDJQJ338811, Project No.106112016CDJXZ338822).

## References

- [1] M. Palacín, A. de Guibert, Why do batteries fail?, *Science* 351 (6273) (2016) 1253292.
- [2] Z. A. Needell, J. McNERney, M. T. Chang, J. E. Trancik, Potential for widespread electrification of personal vehicle travel in the united states, *Nature Energy* 1 (2016) 16112.
- [3] J.-M. Tarascon, M. Armand, Issues and challenges facing rechargeable lithium batteries, *Nature* 414 (6861) (2001) 359–367.
- [4] D. Qian, C. Ma, K. L. More, Y. S. Meng, M. Chi, Advanced analytical electron microscopy for lithium-ion batteries, *NPG Asia Materials* 7 (2015) e193.
- [5] M. S., M. F., Electric vehicle battery technologies: From present state to future systems, *Renew Sustain Energy Rev* 51 (2015) 1004–1012.
- [6] X. Hu, C. Zou, C. Zhang, Y. Li, Technological developments in batteries: A survey of principal roles, types, and management needs, *IEEE Power Energy Mag* 15 (5) (2017) 20–31.
- [7] A. Lahyani, P. Venet, A. Guermazi, A. Troudi, Battery/supercapacitors combination in uninterruptible power supply (UPS), *IEEE Trans Power Electron* 28 (4) (2012) 1509–1522.
- [8] N. A. Chaturvedi, R. Klein, J. Christensen, J. Ahmed, A. Kojic, Algorithms for advanced battery-management systems, *IEEE Control Syst Mag* 30 (3) (2010) 49–68.
- [9] G. L. Plett, Extended Kalman filtering for battery management systems of LiPB-based HEV battery packs: Part 3. state and parameter estimation, *J Power Sources* 134 (2) (2004) 277–292.
- [10] H. Rahimi-Eichi, U. Ojha, F. Baronti, M.-Y. Chow, Battery management system: An overview of its application in the smart grid and electric vehicles, *IEEE Ind Electron Mag* 7 (2) (2013) 4–16.
- [11] L. Zhang, X. Hu, Z. Wang, F. Sun, D. G. Dorrell, A review of supercapacitor modeling, estimation, and applications: A control/management perspective, *Renew Sustain Energy Rev* 81 (2) (2017) 1868–1878.
- [12] L. Lu, X. Han, J. Li, J. Hua, M. Ouyang, A review on the key issues for lithium-ion battery management in electric vehicles, *J Power Sources* 226 (2013) 272–288.
- [13] X. Hu, S. Li, H. Peng, A comparative study of equivalent circuit models for Li-ion batteries, *J Power Sources* 198 (2012) 359–367.
- [14] M. Doyle, T. F. Fuller, J. Newman, Modeling of galvanostatic charge and discharge of the lithium/polymer/insertion cell, *J Electrochem Soc* 140 (6) (1993) 1526–1533.
- [15] C. Zou, C. Manzie, D. Nešić, A framework for simplification of PDE-based lithium-ion battery models, *IEEE Trans Control Syst Technol* 24 (5) (2016) 1594–1609.

- [16] Y. Zhang, H. Yang, Modeling and characterization of supercapacitors for wireless sensor network applications, *J Power Sources* 196 (8) (2011) 4128–4135.
- [17] R. Drummond, D. A. Howey, S. R. Duncan, Low-order mathematical modelling of electric double layer supercapacitors using spectral methods, *J Power Sources* 277 (2014) 317–328.
- [18] T. J. Freeborn, B. Maundy, A. S. Elwakil, Fractional-order models of supercapacitors, batteries and fuel cells: A survey, *Mater Renew Sustain Energy* 4 (3) (2015) 9.
- [19] C. A. Monje, Y. Chen, B. M. Vinagre, D. Xue, V. Feliu-Batlle, *Fractional-order systems and controls: fundamentals and applications*, Springer Science & Business Media, 2010.
- [20] I. Petras, *Fractional-order nonlinear systems: modeling, analysis and simulation*, Springer Science & Business Media, 2011.
- [21] M. D. Ortigueira, *Fractional Calculus for Scientists and Engineers*, Springer, Heidelberg, 2011.
- [22] M. O. Efe, Fractional order systems in industrial automation - a survey, *IEEE Trans Ind Inf* 7 (4) (2011) 582–591.
- [23] A. S. Elwakil, B. J. Maundy, L. Fortuna, G. Chen, Guest editorial: Fractional-order circuits and systems, *IEEE J Emerging Sel Top Circuits Syst* 3 (3) (2013) 297–300.
- [24] K. S. Cole, R. H. Cole, Dispersion and absorption in dielectrics i. alternating current characteristics, *J Chem Phys* 9 (4) (1941) 341.
- [25] S. Westerlund, L. Ekstam, Capacitor theory, *IEEE Trans Dielectr Electr Insul* 1 (5) (1994) 826–839.
- [26] J. Jean, The phasance concept: A review, *Current Topics in Electrochemistry* 4 (1997) 127–136.
- [27] J. Sabatier, P. Lanusse, P. Melchior, A. Oustaloup, *Fractional order differentiation and robust control design*, Vol. 77, Springer, 2015.
- [28] I. Podlubny, *Fractional differential equations: an introduction to fractional derivatives, fractional differential equations, to methods of their solution and some of their applications*, Vol. 198, Academic Press, 1998.
- [29] J. Xu, B. Cao, J. Cao, Z. Zou, A comparison study of the model based SOC estimation methods for lithium-ion batteries, in: *IEEE Veh Power Prop Conf*, 2013, pp. 1–5.
- [30] L. Zhang, X. Hu, Z. Wang, F. Sun, D. G. Dorrell, Fractional-order modeling and state-of-charge estimation for ultracapacitors, *J Power Sources* 314 (2016) 28–34.
- [31] Y. Chen, I. Petras, D. Xue, Fractional order control-a tutorial, in: *American Control Conf*, 2009, pp. 1397–1411.
- [32] R. Caponetto, *Fractional order systems: modeling and control applications*, Vol. 72, World Scientific, 2010.
- [33] C. Zou, C. Manzie, D. Nešić, A. G. Kallapur, Multi-time-scale observer design for state-of-charge and state-of-health of a lithium-ion battery, *J Power Sources* 335 (2016) 121–130.
- [34] L. Zhang, X. Hu, Z. Wang, F. Sun, D. G. Dorrell, Experimental impedance investigation of an ultracapacitor at different conditions for electric vehicle applications, *J Power Sources* 287 (2015) 129–138.
- [35] E. Barsoukov, J. Kim, D. Kim, K. Hwang, C. Yoon, H. Lee, Parametric analysis using impedance spectroscopy: relationship between material properties and battery performance, *J New Mater Electrochem Syst* 3 (4) (2000) 301–308.
- [36] M. E. Orazem, B. Tribollet, *Electrochemical impedance spectroscopy*, Vol. 48, John Wiley & Sons, 2011.
- [37] B.-Y. Chang, S.-M. Park, Electrochemical impedance spectroscopy, *Annual Review Analyt Chem* 3 (2010) 207–229.
- [38] E. Barsoukov, J. R. Macdonald, *Impedance spectroscopy: theory, experiment, and applications*, John Wiley & Sons, 2005.
- [39] C. Zou, X. Hu, Z. Wei, X. Tang, Electrothermal dynamics-conscious lithium-ion battery cell-level charging management via state-monitored predictive control, *Energy* 141 (2017) 250–259.
- [40] H. He, R. Xiong, H. Guo, S. Li, Comparison study on the battery models used for the energy management of batteries in electric vehicles, *Energy Convers Manage* 64 (2012) 113–121.
- [41] D. V. Do, C. Forgez, K. E. K. Benkara, G. Friedrich, Impedance observer for a Li-ion battery using Kalman filter, *IEEE Trans Veh Technol* 58 (8) (2009) 3930–3937.
- [42] W. Waag, D. U. Sauer, Adaptive estimation of the electromotive force of the lithium-ion battery after current interruption for an accurate state-of-charge and capacity determination, *Appl Energy* 111 (2013) 416–427.
- [43] M. Aneke, M. Wang, Energy storage technologies and real life applications—a state of the art review, *Appl Energy* 179 (2016) 350–377.
- [44] R. Kempener, E. Borden, Battery storage for renewables: market status and technology outlook, *Int Renew Energy Agency*, Abu Dhabi, UAE, 2015.
- [45] B. Nykvist, M. Nilsson, Rapidly falling costs of battery packs for electric vehicles, *Nature Climate Change* 5 (4) (2015) 329–332.
- [46] S. Chu, Y. Cui, N. Liu, The path towards sustainable energy, *Nature Materials* 16 (1) (2017) 16–22.
- [47] C. Zou, C. Manzie, D. Nešić, Model predictive control for lithium-ion battery optimal charging, *IEEE Trans Mechatronics* 23 (2) (2018) 947–957.
- [48] W. Han, L. Zhang, Y. Han, Computationally efficient methods for state of charge approximation and performance measure calculation in series-connected battery equalization systems, *J Power Sources* 286 (2015) 145–158.
- [49] S. Alavi, C. Birkl, D. Howey, Time-domain fitting of battery electrochemical impedance models, *J Power Sources* 288 (2015) 345–352.
- [50] Z. Wei, C. Zou, F. Leng, B. H. Soong, K. J. Tseng, Online model identification and state of charge estimate for lithium-ion battery with a recursive total least squares-based observer, *IEEE Trans Ind Electron* 65 (2) (2017) 1336–1346.
- [51] J. Xu, C. C. Mi, B. Cao, J. Deng, Z. Chen, S. Li, The state of charge estimation of lithium-ion batteries based on a proportional-integral observer, *IEEE Trans Veh Technol* 63 (4) (2014) 1614–1621.
- [52] J. P. Schmidt, P. Berg, M. Schönleber, A. Weber, E. Ivers-Tiffée, The distribution of relaxation times as basis for generalized time-domain models for Li-ion batteries, *J Power Sources* 221 (2013) 70–77.
- [53] X. Lin, H. E. Perez, S. Mohan, J. B. Siegel, A. G. Stefanopoulou, Y. Ding, M. P. Castanier, A lumped-parameter electro-thermal model for cylindrical batteries, *J Power Sources* 257 (2014) 1–11.
- [54] U. Westerhoff, K. Kurbach, F. Lienesch, M. Kurrat, Analysis of lithium-ion battery models based on electrochemical impedance spectroscopy, *Energy Technol* 4 (12) (2016) 1620–1630.
- [55] Y. Zou, S. E. Li, B. Shao, B. Wang, State-space model with non-integer order derivatives for lithium-ion battery, *Appl Energy* 161 (2016) 330–336.
- [56] A. Oustaloup, F. Levron, B. Mathieu, F. M. Nanot, Frequency-band complex noninteger differentiator: characterization and synthesis, *IEEE Trans Circuits Syst I* 47 (1) (2000) 25–39.
- [57] F. Merrikh-Bayat, Rules for selecting the parameters of oustaloup recursive approximation for the simulation of linear feedback systems containing  $\pi/\lambda d\mu$  controller, *Commu Nonlinear Sci & Numer Simulat* 17 (4) (2012) 1852–1861.
- [58] W. Waag, S. Käbitz, D. U. Sauer, Application-specific parameterization of reduced order equivalent circuit battery models for improved accuracy at dynamic load, *Measurement* 46 (10) (2013) 4085–4093.
- [59] B. Wang, S. E. Li, H. Peng, Z. Liu, Fractional-order modeling and parameter identification for lithium-ion batteries, *J Power Sources* 293 (2015) 151–161.
- [60] X. Liao, J. Yu, L. Gao, Electrochemical study on lithium iron phosphate/hard carbon lithium-ion batteries, *J Solid State Electrochem* 16 (2) (2012) 423–428.
- [61] B. Wang, Z. Liu, S. E. Li, S. J. Moura, State-of-charge estimation for lithium-ion batteries based on a nonlinear fractional model, *IEEE Trans Control Syst Technol* (2016) 1–9.
- [62] C. Zou, X. Hu, S. Dey, L. Zhang, X. Tang, Nonlinear fractional-order estimator with guaranteed robustness and stability for lithium-ion batteries, *IEEE Trans Ind Electron* 65 (7) (2018) 5951–5961.
- [63] F. Zhong, H. Li, S. Zhong, Q. Zhong, C. Yin, An SOC estimation approach based on adaptive sliding mode observer and fractional order equivalent circuit model for lithium-ion batteries, *Commu Nonlinear Sci & Numer Simulat* 24 (1) (2015) 127–144.
- [64] F. Zhong, H. Li, S. Zhong, State estimation based on fractional order sliding mode observer method for a class of uncertain fractional-order nonlinear systems, *Signal Process* 127 (2016) 168–184.
- [65] H. Mu, R. Xiong, H. Zheng, Y. Chang, Z. Chen, A novel fractional order model based state-of-charge estimation method for lithium-ion battery, *Appl Energy* 207 (2017) 384–393.
- [66] C. Manzie, C. Zou, D. Nešić, Simplification techniques for PDE-based Li-Ion battery models, in: *IEEE Conf on Decision and Control*, Osaka, Japan, 2015, pp. 3913–3921.

- [67] J. Sabatier, M. Merveillaut, J. M. Francisco, F. Guillemard, D. Porcellato, Lithium-ion batteries modeling involving fractional differentiation, *J Power Sources* 262 (2014) 36–43.
- [68] J. Sabatier, J. M. Francisco, F. Guillemard, L. Lavigne, M. Moze, M. Merveillaut, Lithium-ion batteries modeling: A simple fractional differentiation based model and its associated parameters estimation method, *Signal Process* 107 (2015) 290–301.
- [69] X. Li, K. Pan, G. Fan, R. Lu, C. Zhu, G. Rizzoni, M. Canova, A physics-based fractional order model and state of energy estimation for lithium ion batteries. Part I: Model development and observability analysis, *J Power Sources* 367 (2017) 187–201.
- [70] S. E. Li, B. Wang, H. Peng, X. Hu, An electrochemistry-based impedance model for lithium-ion batteries, *J Power Sources* 258 (2014) 9–18.
- [71] C. Zou, X. Hu, Z. Wei, T. Wik, B. Egardt, Electrochemical estimation and control for lithium-ion battery health-aware fast charging, *IEEE Transactions on Industrial Electronics* 65 (8) (2018) 6635–6645.
- [72] Y. Li, J. Yang, J. Song, Design structure model and renewable energy technology for rechargeable battery towards greener and more sustainable electric vehicle, *Renew Sustain Energy Rev* 74 (2017) 19–25.
- [73] Z. Rao, S. Wang, A review of power battery thermal energy management, *Renew Sustain Energy Rev* 15 (9) (2011) 4554–4571.
- [74] Y. Huo, Z. Rao, X. Liu, J. Zhao, Investigation of power battery thermal management by using mini-channel cold plate, *Energy Convers Manage* 89 (2015) 387–395.
- [75] S. Shi, Y. Xie, M. Li, Y. Yuan, J. Yu, H. Wu, B. Liu, N. Liu, Non-steady experimental investigation on an integrated thermal management system for power battery with phase change materials, *Energy Convers Manage* 138 (2017) 84–96.
- [76] Y. Aoki, M. Sen, S. Paolucci, Approximation of transient temperatures in complex geometries using fractional derivatives, *Heat and Mass Transfer* 44 (7) (2008) 771–777.
- [77] J. Reyes-Marambio, F. Moser, F. Gana, B. Severino, W. R. Calderón-Muñoz, R. Palma-Behnke, P. A. Estevez, M. Orchard, M. Cortés, A fractal time thermal model for predicting the surface temperature of air-cooled cylindrical Li-ion cells based on experimental measurements, *J Power Sources* 306 (2016) 636–645.
- [78] S. Barsali, M. Ceraolo, Dynamical models of lead-acid batteries: Implementation issues, *IEEE Trans Energy Convers* 17 (1) (2002) 16–23.
- [79] G. Garcia, J. Bernussou, Identification of the dynamics of a lead acid battery by a diffusive model, *Eur Series Appl Ind Math Proceedings* 5 (1998) 87–98.
- [80] J. Lin, T. Poinot, J.-C. Trigeassou, R. Ouvrard, Parameter estimation of fractional systems: application to the modeling of a lead-acid battery, *IFAC Proceedings* 33 (15) (2000) 983–988.
- [81] J. Sabatier, M. Cugnet, S. Laruelle, S. Grugeon, B. Sahut, A. Oustaloup, J. Tarascon, A fractional order model for lead-acid battery crankability estimation, *Commun Nonlinear Sci Numer Simulat* 15 (5) (2010) 1308–1317.
- [82] M. Cugnet, J. Sabatier, S. Laruelle, S. Grugeon, B. Sahut, A. Oustaloup, J.-M. Tarascon, On lead-acid-battery resistance and cranking-capability estimation, *IEEE Trans Ind Electron* 57 (3) (2010) 909–917.
- [83] Y. Cheng, H. Zhang, S. Lu, C. V. Varanasi, J. Liu, Flexible asymmetric supercapacitors with high energy and high power density in aqueous electrolytes, *Nanoscale* 5 (3) (2013) 1067.
- [84] X. Luo, J. Wang, M. Dooner, J. Clarke, Overview of current development in electrical energy storage technologies and the application potential in power system operation, *Appl Energy* 137 (C) (2015) 511–536.
- [85] M. W. Verbrugge, L. Ping, Microstructural analysis and mathematical modeling of electric double-layer supercapacitors, *J Electrochem Soc* 152 (5) (2005) D79–D87.
- [86] D. Riu, N. Retiere, D. Linzen, Half-order modelling of supercapacitors, in: *IEEE Ind Appl Conf*, Vol. 4, 2004, pp. 2550–2554.
- [87] V. Martynyuk, M. Ortigueira, Fractional model of an electrochemical capacitor, *Signal Process* 107 (2015) 355–360.
- [88] N. Bertrand, J. Sabatier, O. Briat, J.-M. Vinassa, Fractional non-linear modelling of ultracapacitors, *Commun Nonlinear Sci Numer Simulat* 15 (5) (2010) 1327–1337.
- [89] N. Bertrand, J. Sabatier, O. Briat, J.-M. Vinassa, Embedded fractional nonlinear supercapacitor model and its parametric estimation method, *IEEE Trans Ind Electron* 57 (12) (2010) 3991–4000.
- [90] R. Martin, J. J. Quintana, A. Ramos, I. de la Nuez, Modeling of electrochemical double layer capacitors by means of fractional impedance, *J Comput Nonlinear Dyn* 3 (2) (2008) 021303.
- [91] L. Le Lay, Identification fréquentielle et temporelle par modèle non entier, Ph.D. thesis, University of Bordeaux (1998).
- [92] D. Zhou, K. Zhang, A. Ravey, F. Gao, A. Miraoui, Parameter sensitivity analysis for fractional-order modeling of lithium-ion batteries, *Energies* 9 (3) (2016) 123.
- [93] J.-L. Battaglia, O. Cois, L. Puigsegur, A. Oustaloup, Solving an inverse heat conduction problem using a non-integer identified model, *Int J Heat Mass Transfer* 44 (14) (2001) 2671–2680.
- [94] J. Sabatier, M. Aoun, A. Oustaloup, G. Grégoire, F. Ragot, P. Roy, Fractional system identification for lead acid battery state of charge estimation, *Signal Process* 86 (10) (2006) 2645–2657.
- [95] W. Zhu, J.-a. Fang, Y. Tang, W. Zhang, Y. Xu, Identification of fractional-order systems via a switching differential evolution subject to noise perturbations, *Physics Letters A* 376 (45) (2012) 3113–3120.
- [96] L. Lai, Y.-D. Ji, S.-C. Zhong, L. Zhang, Sequential parameter identification of fractional-order Duffing system based on differential evolution algorithm, *Mathematical Problems in Engineering* 2017 (2017) 1–13.
- [97] D.-Y. Liu, T.-M. Laleg-Kirati, O. Gibaru, W. Perruquetti, Identification of fractional order systems using modulating functions method, in: *American Control Conf*, 2013, pp. 1679–1684.
- [98] S. Victor, R. Malti, H. Garnier, A. Oustaloup, Parameter and differentiation order estimation in fractional models, *Automatica* 49 (4) (2013) 926–935.
- [99] W. Allafi, I. Zajic, K. J. Burnham, Identification of fractional order models: Application to 1D solid diffusion system model of lithium ion cell, in: *Progress Syst Eng*, Springer, 2015, pp. 63–68.
- [100] P. E. Jacob, S. M. M. Alavi, A. Mahdi, S. J. Payne, D. A. Howey, Bayesian inference in non-markovian state-space models with applications to battery fractional-order systems, *IEEE Trans Control Syst Technol* PP (99) (2017) 1–10.
- [101] A. Dzieliński, G. Sarwas, D. Sierociuk, Time domain validation of ultracapacitor fractional order model, in: *IEEE Conf Decision and Control*, 2010, pp. 3730–3735.
- [102] T. J. Freeborn, B. Maundy, A. S. Elwakil, Measurement of supercapacitor fractional-order model parameters from voltage-excited step response, *IEEE J Emerg Sel Top Circuits Syst* 3 (3) (2013) 367–376.
- [103] J.-D. Gabano, T. Poinot, H. Kanoun, Lpv continuous fractional modeling applied to ultracapacitor impedance identification, *Control Eng Prac* 45 (2015) 86–97.
- [104] S. Alavi, A. Mahdi, P. E. Jacob, S. J. Payne, D. A. Howey, Structural identifiability analysis of fractional order models with applications in battery systems, *arXiv preprint arXiv:1511.01402*.
- [105] X. Hu, S. Li, H. Peng, F. Sun, Robustness analysis of state-of-charge estimation methods for two types of Li-ion batteries, *J Power Sources* 217 (2012) 209–219.
- [106] Q. Yang, J. Xu, B. Cao, X. Li, A simplified fractional order impedance model and parameter identification method for lithium-ion batteries, *PloS One* 12 (2) (2017) e0172424.
- [107] L. Zhang, Z. Wang, X. Hu, F. Sun, D. G. Dorrell, A comparative study of equivalent circuit models of ultracapacitors for electric vehicles, *J Power Sources* 274 (2015) 899–906.
- [108] J. Jiang, H. Ruan, B. Sun, W. Zhang, W. Gao, L. Y. Wang, L. Zhang, A reduced low-temperature electro-thermal coupled model for lithium-ion batteries, *Appl energy* 177 (2016) 804–816.
- [109] N. Naim, D. Isa, R. Arelhi, Modelling of ultracapacitor using a fractional-order equivalent circuit, *Int J Renew Energy Technol* 6 (2) (2015) 142–163.
- [110] H. Kanoun, J.-D. Gabano, T. Poinot, Fractional modeling of ultracapacitors dynamic behavior, *IFAC Proceedings* 44 (1) (2011) 13978–13983.
- [111] K. Liu, K. Li, C. Zhang, Constrained generalized predictive control of battery charging process based on a coupled thermoelectric model, *J Power Sources* 347 (2017) 145–158.
- [112] K. Liu, K. Li, Z. Yang, C. Zhang, J. Deng, An advanced lithium-ion battery optimal charging strategy based on a coupled thermoelectric model, *Electrochim Acta* 225 (2017) 330–344.
- [113] X. Han, M. Ouyang, L. Lu, J. Li, Y. Zheng, Z. Li, A comparative study of commercial lithium ion battery cycle life in electrical vehicle: Aging mechanism identification, *J Power Sources* 251 (2014) 38–54.

- [114] R. Xiao, J. Shen, X. Li, W. Yan, E. Pan, Z. Chen, Comparisons of modeling and state of charge estimation for lithium-ion battery based on fractional order and integral order methods, *Energies* 9 (3) (2016) 184.
- [115] X. Li, K. Pan, G. Fan, R. Lu, C. Zhu, G. Rizzoni, M. Canova, A physics-based fractional order model and state of energy estimation for lithium ion batteries. Part II: Parameter identification and state of energy estimation for LiFePO<sub>4</sub> battery, *J Power Sources* 367 (2017) 201–209.
- [116] I. Podlubny, Fractional-order systems and PI<sup>λ</sup>D<sup>μ</sup>-controllers, *IEEE Trans Automatic Control* 44 (1) (1999) 208–214.
- [117] L. Meng, D. Xue, Design of an optimal fractional-order PID controller using multi-objective GA optimization, in: *Chinese Control and Decision Conf, IEEE, 2009*, pp. 3849–3853.
- [118] M. Ö. Efe, Integral sliding mode control of a quadrotor with fractional order reaching dynamics, *Trans Inst Meas Control* 33 (8) (2011) 985–1003.
- [119] B. Zhang, Y. Pi, Y. Luo, Fractional order sliding-mode control based on parameters auto-tuning for velocity control of permanent magnet synchronous motor, *ISA Trans* 51 (5) (2012) 649–656.