

THESIS FOR THE DEGREE OF LICENTIATE OF ENGINEERING

# Cost-Effective Pathways for Gasification-Based Production of Biofuels

Johan Ahlström

Department of Space, Earth and Environment

CHALMERS UNIVERSITY OF TECHNOLOGY

Gothenburg, Sweden 2018

Cost-Effective Pathways for Large-Scale Gasification-Based Production of Biofuels  
Johan Ahlström

© JOHAN AHLSTRÖM, 2018.

Department of Space, Earth and Environment  
Chalmers University of Technology  
SE-412 96 Gothenburg  
Sweden  
Telephone + 46 (0)31-772 1000

Printed by Chalmers Reproservice  
Gothenburg, Sweden 2018

## ABSTRACT

A considerable number of studies indicate that biomethane produced through gasification of lignocellulosic biomass could contribute significantly to greenhouse gas emissions reduction in the transport sector. However, the production costs are high compared to fossil-based alternatives, which has limited deployment of the technology. This thesis evaluates three possible options for decreasing the cost of gasification-based biomethane production: (i) utilization of shredded bark as feedstock, (ii) integration of power-to-gas concepts, (iii) process integration of the biomethane plant with a sawmill to increase the well-to-tank efficiency of the value chain. Utilization of low-value bark biomass as feedstock could potentially reduce the costs of biomethane production as well as releasing high quality biomass to be used for more specialized purposes. The use of electricity to increase the product output from gasification-based biofuel production constitutes an additional possibility for increased cost efficiency. Hydrogen produced from electrolysis of water can be reacted with effluent CO<sub>2</sub> streams in the biomethane plant to produce additional biomethane, thereby increasing the biomethane output per unit of biomass fed to the plant. By integrating the biomethane plant with a sawmill, biomass residues from the sawmill can be used as feedstock and the excess heat from the gasifier can be recovered to partially satisfy the heating requirements of the biomethane plant.

The results show how all evaluated pathways could contribute to decreasing production costs for gasification-based biomethane. Analysis of demonstration tests performed at industrial scale show that bark gasification is technically feasible for production of advanced biofuels. The feedstock related cost for production of biomethane from bark (dried to about 8%) is in the range of 24.2-32.7 EUR/MWh; a reduction of about 35-45% compared to wood pellets. The evaluation of four different process configurations for utilization of hydrogen produced from electrolysis of water (power-to-gas) in the biomethane plant show that the operating revenue increases with increased addition of hydrogen. The results for the sawmill-integrated gasification-based liquefied biomethane production plant show that the size of the production plant has the largest impact on fuel production cost, followed by feedstock transportation costs for larger plants. It can be concluded that there are clear gains to be obtained by integrating gasification-based liquefied biomethane production at sawmill sites, and that the gains increase with the size of the sawmill.

Keywords: Biorefinery, Gasification, SNG, Biomethane, bark, power-to-gas, hydrogen, heat integration, sawmill



## List of publications

This thesis is based on the work presented in the following papers:

- I. Bark as a feedstock in dual fluidized bed gasification – operability, efficiency and economics. Ahlström, J.M., Alamia, A., Larsson, A., Breitholtz, C., Harvey, S., Thunman, H. Submitted for publication in *International Journal of Energy Research*
- II. Forest residues gasification integrated with electrolysis for production of SNG – modelling and assessment. Ahlström, J.M., Harvey, S., Papadokonstantakis, S. Proceedings of the Process Systems Engineering Conference, *PSE 2018*, 1-5 July 2018, San Diego, USA
- III. Value chains for integrated production of liquefied bio-SNG at sawmill sites – Techno-economic and carbon footprint evaluation. Ahlström, J.M., Pettersson, K., Wetterlund, E., Harvey, S. *Applied Energy*, Volume 206, 15 November 2017, Pages 1590-1608

Johan Ahlström is the main author of all three papers. Professor Simon Harvey was the supervisor of Paper III and contributed with supervision and reading of Papers I and II, he is also the main supervisor of the research project. Dr. Karin Pettersson and Associate Professor Elisabeth Wetterlund co-supervised the work of Paper III. Professor Henrik Thunman was the main supervisor of Paper I which was co-supervised by Dr. Alberto Alamia. Dr. Anton Larsson and Dr. Claes Breitholtz contributed with experimental data and reading of Paper I. Associate Professor Stavros Papadokonstantakis was the main supervisor for Paper II, which is based on a Master thesis project supervised by Johan Ahlström and examined by Stavros Papadokonstantakis.

### **Related work not included in this thesis:**

- A framework for techno-economic market evaluation of biorefinery concepts  
Bryngemark, E., Zetterholm, J., Ahlström, J.M.  
Submitted for publication in *Sustainability* (April 2018)

The Paper is a re-worked version of a conference paper presented at the SDEWES conference in Dubrovnik, Croatia, October 2017, which in turn was based on a report presented within the framework of the research school Forskarskola energisystem.



# Table of Contents

Chapter 1 Introduction .....	1
1.1 Objective & Scope .....	3
1.2 Outline and overview of appended papers .....	3
Chapter 2 Background and Related Work.....	6
2.1 Biomethane .....	7
2.2 Biomass gasification.....	8
2.3 Power-to-gas .....	10
2.4 Process integration of biorefinery concepts.....	11
2.5 Biofuel value chains .....	13
2.6 Bark .....	13
Chapter 3 Studied Processes & Systems .....	14
3.1 Bark feedstock pathway.....	15
3.1.1 Dual fluidized bed (DFB) Gasification .....	15
3.1.2 Operation with bark.....	16
3.2 Power to gas pathway .....	17
3.2.1 Direct blown gasification plant .....	17
3.2.2 Power-to-gas.....	17
3.3 Process integrated value chain pathway .....	19
Chapter 4 Methodology.....	21
4.1 Bark feedstock pathway.....	22
4.1.1 Stochastic model .....	22
4.1.2 DFB gasifier extrapolation algorithm .....	23
4.2 Power to gas pathway .....	24
4.2.1 Power-to-gas process model.....	24
4.3 Process integration.....	24
4.4 Process integrated value chain pathway .....	25
4.4.1 Value chain model.....	25
4.5 Key performance indicators.....	26
4.5.1 Thermodynamic indicators.....	26
4.5.2 Economic performance indicators.....	28
Chapter 5 Results & Discussion.....	31
5.1 Bark feedstock pathway.....	31

5.1.1	Mass and energy balance.....	31
5.1.2	Extrapolation and economic results .....	32
5.2	Power to gas pathway .....	34
5.3	Process integrated value chain pathway .....	35
5.3.1	Energy balances.....	36
5.3.2	Economic performance .....	38
Chapter 6 Conclusions .....		41
Chapter 7 Outlook and Future Work.....		45
References .....		47
Abbreviations .....		52
Acknowledgements .....		53



*Till Mamma.*

*“Taking a new step, uttering a new word, is what people fear most.”*  
— Fjodor Dostojevskij, *Crime and punishment*



# Chapter 1

## Introduction

---

In 2017, Sweden adopted a new climate policy framework including new climate goals, a Climate Act and plans for a climate policy council. The new national climate goals call for net negative greenhouse gas (GHG) emissions by 2045, which implies that emissions should be 85% lower than in 1990; the remaining 15% can be achieved through complimentary measures such as investments in renewables in other countries (Swedish Environment and Agriculture Committee, 2017). To achieve such reductions, several measures will be necessary, e.g. increased deployment of electricity generation from renewable energy sources, increased energy efficiency and behavioral changes. Most research also indicates that the future will see an increased demand for biomass; biorefineries producing biofuels and biochemicals are likely to play a significant role in achieving the transition towards a fossil-free society, especially in forest rich countries such as Sweden (Fulton et al., 2015, Connolly et al., 2014). Replacing fossil fuels with fuels produced from biomass can substantially decrease net GHG emissions.

However, many sectors will compete for the biomass. Increased demand can be expected within many sectors including construction (Bejo, 2017), industrial processes (IEA, 2013), electricity and heat generation (Kwon and Østergaard, 2013, Lund et al., 2011), motor fuels (Cornelissen et al., 2012). Furthermore, the demand from existing consumers of forest biomass will remain e.g. pulp and Paper Industry. Sweden has adopted a target of a fossil-independent transport sector by 2030 (SOU, 2013). Similar objectives have been stated by the European Union that has committed to a decrease in GHG emissions from all branches of transportation by at least 60% by 2050 (The European Commission, 2018). As a consequence, demand for biofuels produced from lignocellulosic feedstock is projected to increase significantly in the future (SOU, 2013). The International Energy Agency (IEA) anticipates that the total share of bioenergy in the global energy mix will have to increase from 4.5% (2015) to around 17% in 2060 in order to achieve the 2°C global temperature increase target (IEA, 2017); the major part of this increase will be used for transportation.

While conclusions from research indicate clearly that biomass will be required in the energy mix, critique against biomass being harvested for energy purposes is also growing within Europe. Chatham House published two reports in 2017 (Brack, 2017b, Brack, 2017a) expressing criticism on the sustainability of using biomass for energy purposes. The main arguments are that biomass should not be considered carbon neutral when combusted, as it emits more carbon per unit of energy than most fossil fuels and that there is a loss of soil carbon when forest residues are taken from the forest. Therefore, Chatham House argues, the EU should no longer consider biomass to be carbon neutral. The application of such a recommendation would arguably have a large impact on the future of biofuels. However, according to the argumentation presented, biomass which would otherwise be combusted as waste can be exempted from such argumentation. It can therefore be concluded that forest residues such as bark or waste construction wood should be considered as carbon neutral if used for biofuel production.

## Introduction

Gasification is a technology option suitable for large scale conversion of biomass to higher value energy carriers (Huber et al., 2006). Gasification is a thermo-chemical process in which biomass is converted to a product gas. The product gas can be used to synthesise a variety of fuels, e.g. biomethane, bio-diesel through the Fisher Tropsch process and aviation fuels (Thunman et al., 2018), or be used as a feedstock in the chemical industry (Arvidsson et al., 2015b).

Recent years have seen a substantial development within the field of gasification and several plants have been commissioned both on a demonstration and commercial level. For instance, the GoBiGas plant in Gothenburg, Sweden, is a 20 MW<sub>biomethane</sub> plant based on indirect fluidized bed gasification technology. The plant is currently the only gasification plant integrated with a full downstream biomethane fuel synthesis unit (Alamia et al., 2017b). Regardless of this development and the clear confirmation that production of biofuels in commercial scale is possible, there is currently little to no ongoing construction of large scale gasification plants with downstream upgrading. For instance, E.ON's plans for construction of a commercial scale (1.5 TWh/yr) gasification plant for biomethane (SNG) production in Landskrona (Sweden), were discontinued in 2013 (Esping, 2013) and the extension of the GoBiGas project was discontinued in 2015 (Sveriges radio, 2015). Operation of the existing GoBiGas plant was canceled in April 2018 (Fouad Youcefi, 2018). The main reason for this development is the difficulty to produce biofuels at a cost that can compete with fossil fuels.

Different policy instruments have been implemented to increase the economic competitiveness of biofuels. For example, biofuels are exempted from energy and carbon taxes in Sweden (The Swedish Government, 2016). However, the tax exemption is only granted on an annual basis. Such policy time horizons are too short, which creates uncertainty for investors (Peck et al., 2016). Therefore, a statutory emissions reduction obligation was introduced for motor fuels in Sweden in 2017. According to the obligation, all fuel suppliers with a tax liability for gasoline and/or diesel will need to comply with fixed levels of certified greenhouse gas emissions reduction compared to fossil gasoline and diesel fuels. This should be achieved with an increase in drop-in biofuels, i.e. increasing the blend of biofuels into their fossil counterparts. By 2030, all producers will need to demonstrate that their fuels reduce GHG emissions from gasoline and diesel by 40% compared to pure fossil alternatives (The Swedish Energy Agency, 2017). However, the cost of producing biofuels is currently high compared to fossil fuels. It is thus essential to lower the production costs for biofuel production, in order to make biofuels more competitive and thereby stimulate investments in new plants.

In summary, the technology for large-scale conversion of biomass to biofuels through gasification has been successfully demonstrated in research, pilot, demonstration and commercial scale plants. Furthermore, there are clear indications that biofuels will be necessary in order to meet climate mitigation targets in the transportation sector. However, the demand for biomass is expected to grow within many sectors, and concerns also have been raised about the climate neutrality of biomass and biofuels. As a result, there is a clear demand for efficient processes as well as the capability to use biomass waste streams as feedstock. Additionally, production of biofuels from lignocellulosic biomass is currently unable to compete with fossil fuels, despite technological breakthroughs and current policy instruments.

It can thus be concluded that there is a research need to identify and evaluate possible pathways for large scale implementation of biomass gasification and downstream conversion to biofuels at a low cost. Increased use of forest residues streams as feedstock could contribute significantly to achieving this objective. This thesis presents evaluation of three different pathways to increase the competitiveness of producing bio-methane through gasification.

### 1.1 Objective & Scope

The aim of this thesis is to evaluate opportunities for decreasing costs for gasification based production of biofuels, primarily bio-methane, in both liquid (LBG) and gaseous form. Biomethane can be produced with high efficiency and is seeing an increased demand from the transportation sector (see Section 2.1). The thesis focuses on three different aspects of the value chain for gasification-based biomethane production:

- The possibility of using low-cost biomass **feedstock**.
- The possibility of utilizing new **technology** to increase the output of a gasification-based biorefinery.
- The possibility of achieving an overall efficient **value chain configuration** from well-to-tank, to decrease costs.

These aspects are in turn investigated through three specific pathways. All pathways imply modification of a standard biomass gasification value chain concept:

1. Utilizing shredded bark as feedstock for a dual fluidized bed (DFB) gasifier.
2. Implementation of a power-to-gas concept, where hydrogen is produced through electrolysis of water and used to increase the fuel output of a gasification-based biomethane plant.
3. Identification of process integration opportunities along the value chain, to increase the overall cost efficiency for generation of liquefied bio-methane.

### 1.2 Outline and overview of appended papers

The work presented in this thesis is based on three appended papers, referred to by Roman numbers in the text:

- I. Bark as a feedstock in dual fluidized bed gasification – operability, efficiency and economics
- II. Forest residues gasification integrated with electrolysis for production of SNG – modelling and assessment
- III. Value chains for integrated production of liquefied bio-SNG at sawmill sites – Techno-economic and carbon footprint evaluation.

The different pathways investigated in this work are related to three general aspects: feedstock, technology and value chain. Figure 1 shows how the three appended papers relate to these different aspects.

## Introduction

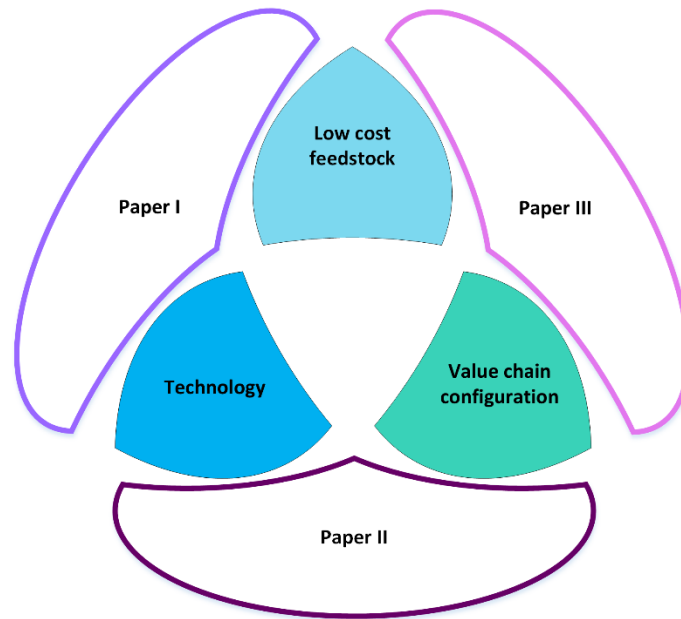

*Figure 1. Overview of papers included in this thesis and how they relate to the different aspects of biomass gasification considered.*

Paper I investigates the pathway of using shredded bark as the main feedstock in a DFB gasifier plant. This implies switching feedstock, which is directly related to the technology in itself. Feedstock switching requires that the technical performance of the gasification concept has to be re-assessed, since modifications of the technical operation of the plant are likely to be necessary. Paper II evaluates usage of electricity to produce hydrogen, which in turn is used to increase the yield of gasification-based biofuels production. This concept opens up a new value chain, in which the electricity grid must be considered. Furthermore, by combining an electrolyser unit with the gasification plant, a new type of technology is considered. Paper III introduces a new value chain, and focuses on utilizing forest residues and bark as feedstock in a DFB gasification process integrated with a sawmill, with the feedstock being entirely or partly provided from the sawmill.

Depending on the scope of the evaluation of the different pathways, a different perspective is adopted in the evaluation, corresponding to three different levels of system evaluation, as shown in Figure 2.

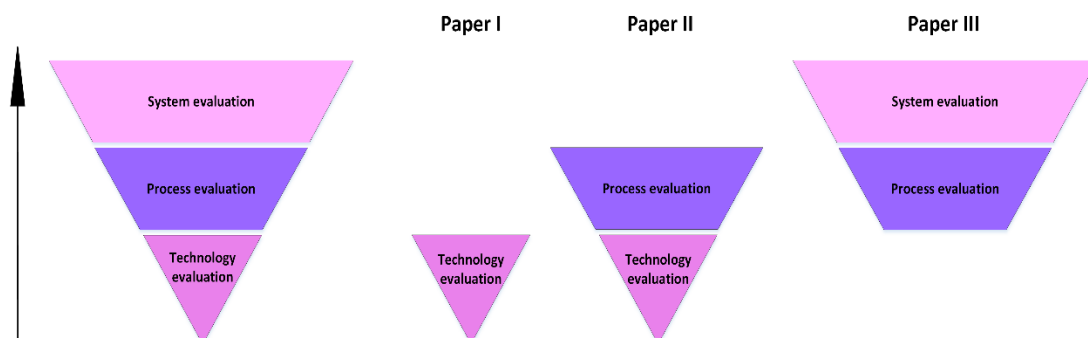

*Figure 2. Classification of different levels of evaluation.*

## Introduction

The evaluation levels considered include evaluation and validation of a specific technology, followed by plant level evaluation, and finally system level evaluation. The appended papers all focus on different levels of evaluation, depending on the concept to be evaluated.

Paper I focuses on evaluating the cost implications of using shredded bark as feedstock for gasification. Since the change of feedstock mainly affects how the gasifier is operated, the concept is evaluated at a technological level. In Paper II, the aim is to assess the possible process layout of a gasification based biomethane plant that uses hydrogen produced through electrolysis to increase the biofuel yield for a fixed amount of biomass feedstock. Thus, focus is placed on process evaluation, with a certain degree of technical evaluation. In Paper III, the aim is to evaluate how the sizing of a gasification based LBG plant integrated with a sawmill impacts the performance of the entire value chain. To assess such a concept, a combination of system and process perspectives is necessary. The former is used to estimate the energy and mass balance together with the yield of the process, which is necessary to investigate the possibilities of process integration. The latter is necessary to relate the processes to the value chain.

## Introduction



# Chapter 2

## Background & Related Work

---

### 2.1 Biomethane

Due to the positive fuel characteristics of liquefied natural gas (LNG), there are a number of ongoing political initiatives to increase the demand for this fuel. The EU-co-financed Northern European LNG Infrastructure project was initiated in 2015. The project aims at developing an LNG distribution infrastructure for ship bunker fuel in the Baltic Sea region (The Danish Maritime Authority, 2012). LNG is increasingly being adopted by shipping companies and ship manufacturers to decrease NO<sub>x</sub> and SO<sub>x</sub> emissions as well as CO<sub>2</sub> emissions. The demand for LNG is also increasing in the trucking industry. The EU-financed “LNG blue corridors” project presents suggestions for road corridors with evenly distributed LNG-fueling stations that could enable a broad market implementation of heavy duty vehicles (HDV) running on LNG in Europe (LNG Blue Corridors project, 2017). Volvo trucks recently (2018) released their new LNG powered long-haul truck (Volvo trucks, 2017).

Extensive work has been put into estimating the carbon footprint and economic performance of producing biomethane (also known as synthetic natural gas, SNG) from biomass feedstock. A process design and evaluation study of a direct, steam blown, biomass gasification plant for biomethane production was performed by Gröbl et al. (2012). The study focused on small-scale gasification plants for decentralized biomethane production and indicated that a cold gas efficiency of 68% could be achieved if wood pellets (19.55% moisture content by weight) are used as feedstock. Isaksson et al. (2016) compared different fuel synthesis options from a direct, air-blown gasification plant. Production of Fisher-Tropsch diesel, ethanol and biomethane were compared in terms of net annual profit, and it was concluded that production of biomethane performs best from an economic point of view.

Alamia et al. (2016a) performed a well-to-wheel (WTW) study of production of biomethane for use as fuel for heavy duty vehicles within the transport sector of the European Union. Their results indicate a GHG emissions reduction potential of up to 67%, depending on engine type, compared with fossil diesel. The study was based on data from the GoBiGas demonstration biomethane plant. Pettersson et al. (2015) investigated opportunities for future cost-efficient production of biofuels in Sweden, considering different possible plant locations. The results indicate that biomethane, especially integrated production at sawmill sites, is an interesting fuel. The main reason is that gasification-based production of biomethane achieves a high biomass-to-product yield, as well as a high overall system energy efficiency due to large quantities of high temperature excess heat that can be recovered and used for other purposes. The energy, greenhouse gas (GHG) and cost performance of value chains for production of biomethane as a vehicle fuel were evaluated in a well-to-wheel analysis by Börjesson et al. (2016). Their results indicate that using renewable methane as a vehicle fuel results in reduction of WTW GHG emissions of 80% or higher compared to vehicles operated with fossil diesel or gasoline. Furthermore, the WTW costs for biomethane were shown to be similar to those of comparable fossil fuels (2016).

Börjesson et al. (2013) and Ekbohm et al. (2012) investigated the perspectives for biomethane production from gasified biomass in terms of reduction of GHG emissions (7.5–8.5 metric tons CO<sub>2-eq</sub>/ha land use) and production costs (5.5-7 SEK/l of gasoline equivalent). Both studies concluded that biomethane is an attractive fuel compared to other biofuel alternatives, mainly due to low production costs. However, they also emphasized the potential risk for expensive distribution costs due to the low energy density of the fuel. Hagberg et al. (2016) explored system interactions related to future bioenergy utilization and cost-efficient bioenergy technology in Sweden for the year 2050. The study was based on results from a bottom-up, cost-optimization model of the Swedish energy system. The results suggest that system integration of biofuel production improves system cost-efficiency. Production of biomethane accounts for a significant part of the fuel supply in all studied cases. For the cases where heat integration with existing industrial plants is included, plants combining production of ethanol, biomethane and electricity achieved the highest performance.

## 2.2 Biomass gasification

Biomass gasification is the thermochemical conversion of lignocellulosic biomass to a raw gas mixture consisting mainly of CO, CO<sub>2</sub>, CH<sub>4</sub>, H<sub>2</sub>, steam, as well as other trace gas components and heavier hydrocarbons known as tar. By cleaning the gas of tar and CO<sub>2</sub>, and processing it in chemical reactors, a variety of biofuels can be produced. Gasification can be performed using different technologies that differ mainly by the type of gasification medium that is used and how heat is supplied to the process. The three main types of gasification technologies are direct blown, indirect dual fluidized bed (DFB) and entrained flow gasification. In this thesis, the two former technologies are considered.

In indirect DFB gasification, the heat required for gasification of biomass is produced through combustion of a fraction of the biomass in a separate reactor and the heat is transferred to the gasification reactor with a bed material. DFB gasification has undergone substantial development during the last 15 years. It was first demonstrated in the Güssing plant, Austria, with an 8 MW<sub>biomass</sub> gasifier (Bolhàr-Nordenkampf et al., 2002). Further development was achieved in the research gasification unit at Chalmers University of Technology in Sweden (Thunman et al., 2018) and in Senden, Germany with a 16 MW<sub>biomass</sub> gasifier (4biomass Project, 2018). The GoBiGas plant in Gothenburg, Sweden was constructed in 2014 and is to date (2018) the only commercial scale plant based on indirect gasification with a full downstream synthesis process. The plant is designed to gasify up to 32 MW<sub>biomass</sub> and the product gas is synthesized to biomethane with a production capacity of up to 20 MW<sub>biomethane</sub> (Alamia et al., 2017b). The plant was designed to operate using wood pellets as feedstock. However, different feedstocks have been considered and/or tested for future operation in order to lower production costs. The overall biomass to product yield is around 65 %<sub>LHVdaf</sub> when converting wood pellets to biomethane (Alamia et al., 2016b). During 2018 (April), operation of the plant was terminated until further notice (Fouad Youcefi, 2018).

The techno-economic performance of large scale production of biofuels based on DFB gasification was investigated by Alamia et al. (2017a). Their results indicate that by optimizing a gasifier concept similar to the GoBiGas plant, the cold gas efficiency could be increased from approximately 72% to 84%. The optimization would involve lower operating temperatures, pre-

## Background & Related Work

heating of the fuel, decreasing heat losses and lower moisture content of the feedstock, which all are technically feasible for a commercial scale plant. The results indicate a production cost of biomethane of 60 EUR/MWh, equivalent to 0.54 EUR/liter gasoline, for a 200 MW DFB gasifier plant (Thunman et al., 2018).

In contrast to DFB gasification, direct blown gasification constitutes a simpler process with only one gasifier reactor. Since the fuel conversion process occurs in a single bed reactor, part of the fuel must be combusted inside the reactor to provide the heat required for feedstock conversion. Oxygen is required and the produced raw gas has a higher concentration of CO<sub>2</sub>. Additionally, if the gas product is to be used for synthesis purposes, air cannot be used as gasification medium, since the nitrogen dilutes the product gas; therefore direct blown gasifiers for synthesis purposes require oxygen plants.

Direct air blown gasification has been demonstrated at several sites. In Lahti, Finland, a direct blown gasifier has been in operation since 2002, fueled by a mix of biomass and residual waste as feedstock (Granatstein, 2002). The plant fuel capacity is equivalent to 160 MW<sub>biomass</sub> and the product gas is used for heat and power production. A 30 MW<sub>biomass</sub> air blown, circulating fluidized bed (CFB) gasifier was operated discontinuously from 1987 to 2014 with different feedstocks, including bark, to provide combustion gas to the lime kiln at the Värö pulp mill in Halland, Sweden (Wadsborn et al., 2007). Since air was used as gasification media, the gas produced had a low heating value of 6-7 MJ/kg; the total fraction of CO<sub>2</sub>, CO, H<sub>2</sub> and CH<sub>4</sub> was around 20% (Waldheim, 2015).

Indirect, oxygen and steam blown gasification for synthesis purposes has been the subject of substantial research. Hannula and Kurkela (2013) investigated concepts for large scale (300MW<sub>th</sub>) generation of biomass gasification. They concluded that it is possible to produce methanol at a cost of 58–65 €/MWh, DME at a cost of 58–66 €/MWh, Fischer-Tropsch liquids at a cost of 64–75 €/MWh and synthetic gasoline at a cost of 68–78 €/MWh. Gassner and Maréchal (2012) performed thermo-economic optimization of a polygeneration plant producing biomethane, power and heat from gasified lignocellulosic biomass. Their results indicate that a systematically optimized process flowsheet could achieve conversion efficiencies of 66-75% from wood (50% m.c by weight) to biomethane (LHV basis), for concepts that include simultaneous production of heat and electricity.

The main drawback of DFB technology is the technical complexity related to a system with two interconnected reactors. However, this technology also presents advantages over direct, oxygen blown gasifiers: the absence of an oxygen plant, lower CO<sub>2</sub> levels in the product gas compared to oxygen blown gasification, and the possibility to control the catalytic activity within the reactor. The concentration of CH<sub>4</sub> in the raw gas is also higher in DFB gasification, due to lower gasification temperature, which constitutes an additional benefit if the intended end-product is methane.

The simpler design of the direct blown gasification technology might entail lower investment costs for the gasifier, since only one reactor is required. Direct-blown gasification reactors are also relatively simple to pressurize, which means that the reactor volume can be kept smaller. This means that the reactor cost could possibly be lower for large plants. In terms of efficiency

and fuel generation cost, research diverges between indirect and direct gasification plants. Heyne et al. (2013) performed an exergy-based analysis to compare indirect to direct gasification of biomass. They concluded that there are no significant differences in performance between the two technologies. Tock et al. (2010) performed a superstructure optimization to compare different process design routes to produce different biofuels through biomass gasification. The fuels included methanol, Fischer Tropsch diesel and Dimethyl ether (DME) and entrained flow, indirectly heated and directly heated gasifiers were included in the superstructure. The results showed that the choice of gasifier has the largest impact on performance in terms of process design choices and that DFB gasification constitutes the best alternative for all fuels considered. In a previous report (Gassner and Maréchal, 2009), it was concluded that if the intended end-product is biomethane, direct, pressurized, oxygen and steam blown, gasification is the superior option due to the enhanced possibility to recover heat for electricity co-generation in a Rankine cycle. The resulting fuel generation cost for a 150MW<sub>th, wood</sub> plant was shown to be in the range of 59-97 EUR/MWh<sub>biomethane</sub>.

### 2.3 Power-to-gas

In this Thesis power-to-gas concepts refer to the use of electricity to produce hydrogen and oxygen through electrolysis of water. The produced gas streams can then be used as products in their own right, or be further synthesised into a variety of products. For the gas to be synthesised to other products, a carbon source is required, often in the form of carbon dioxide. If the end-product is to be used as a fuel, the final product is often denoted electrofuel. For a thorough review of the concept, refer to (Brynolf et al., 2018). In this thesis, the power-to-gas concept considered combines an electrolysis unit generating hydrogen and oxygen with a direct-blown biomass gasification plant. Such a concept entails multiple benefits. When the raw gas from a gasifier is used for synthesis purposes, the CO<sub>2</sub> remaining after the upgrading step has to be removed, which requires expensive and energy-intensive sequences of separation steps (see e.g. Alamia et al. (2017b)). Hence, converting the remaining CO<sub>2</sub> into valuable products could significantly improve the economic performance of the process. Since CO<sub>2</sub> is available in high concentrations in the raw gas, it is also simpler to separate (compared to e.g. flue gases). Electrolysis of water also produces one unit of O<sub>2</sub> per two units of H<sub>2</sub>. If direct gasification is used, the oxygen can be directly used in the gasifier, thus the load of the process oxygen plant can be lowered and possibly, from a design perspective, be made smaller.

There are several ways in which electricity can be used directly or indirectly to increase the output of a gasification process. With DFB gasification, direct heating of the combustion reactor was investigated by Alamia et al. (2017c). By partly using electricity to heat the bed material in the gasifier, a larger fraction of the char from the gasifier can be converted to raw gas, rather than being combusted. Thereby the overall biomass-to-gas yield of the plant is increased. The study concluded that it is possible to reach a cold gas efficiency of 91% (LHV<sub>daf</sub>) if using 4.8MW of electricity for a 100MW<sub>biomass</sub> plant based on the same process design as the GoBiGas plant. The total energy efficiency of the concept is increased from 81% to 85% due to more efficient heating.

Another option is to mix H<sub>2</sub> with the raw gas after the tar cleaning steps, thus reducing, or removing, the requirement of the water-gas-shift reaction before the methanation step. This

option was investigated by Wagner et al. (2015), who assessed integration of three different sizes of alkaline electrolyser with a DFB gasifier using wood chips as feedstock. The smallest sized unit produced enough H<sub>2</sub> to completely avoid using the water-gas-shift reactor, whereas the largest size unit produced enough H<sub>2</sub> to convert all carbon in the gas to methane. They suggest a polygeneration concept where the produced biomethane is sold when electricity prices are low and used to fuel a gas turbine to generate electricity when prices are high. The study showed that the exergy efficiency is decreased as a result of integration of the electrolysis unit but that the environmental performance of the plant is increased if more carbon-free electricity is used.

H<sub>2</sub> can also be used to react with CO<sub>2</sub> to produce methane through the Sabatier reaction. Gassner and Maréchal (2009) evaluated this concept in a super-structure optimization framework, with a focus on the impact of the electrolyser on process design in terms of economic, thermodynamic and environmental performance. They concluded that exergy and energy efficiencies are increased for both direct and indirect BFB gasification, by appropriate integration of an electrolyser. They also showed that if electricity is available at the cost of generation or occasionally even cheaper, the profits of the plant will increase. Alamia et al. (2017c) also evaluated the possibility of integrating an electrolyser with a DFB gasification process. Their results, indicate that it is possible to achieve a cold gas efficiency of 94.7% and a total system energy efficiency of 81% if the quantity of electricity supplied to the process is maximized.

The possibility of integrating an electrolysis unit with a biomass gasification plant has been investigated in a number of previous research efforts. Different process configurations have been assessed for at least two types of gasifiers. However, research is still lacking regarding assessment of the availability of electricity to drive the electrolyser unit on the process design. Since the electricity price will determine when it is beneficial to produce hydrogen, the electricity price will have an impact on process design. Possible research questions are, for instance, whether it is desirable to operate the process with hydrogen only when it is produced, or if large enough hydrogen storage tanks should be designed to continuously feed the process with hydrogen, and in that case how large the tanks should be.

## 2.4 Process integration of biorefinery concepts

Efficient biomass use can be achieved by integrating the process with host industries, for utilization of excess heat and other by-products (Hosseini and Shah, 2011, Hagberg et al., 2016). Process integration entails that heat is cascaded between processes with the aim of making the combined process more energy efficient than the combination of the constituent plants operating in stand-alone mode (see e.g. Kemp (2011)). Both indirect and direct blown gasification occur at high temperature and generate major quantities of excess heat, hence there are significant energy savings to be made through heat integration. Integration with traditional forest industry plant is of particular interest since such plants have a continuous need for process heat, often have biomass by-products from their main processes, and have experience in operating large-scale biomass supply chains.

## Background & Related Work

Previous studies of gasification-based biofuel production, comparing process integrated facilities to stand-alone production, confirm that co-locating and integrating biorefineries with existing industrial plants is beneficial from an energy perspective and results in lower fuel production costs. Heyne et al. (2012) showed how production of electricity as a by-product from a biomethane plant can be increased by a factor 2.5-10 if the plant is integrated with a CHP plant, depending on the type of biomass dryer that is used. Andersson et al. (2014) showed how the total energy efficiency of a biorefinery plant based on an entrained flow gasifier can be increased by 7 percentage points if the unit is heat integrated with an existing chemical pulp and paper mill. Consonni et al. (2009) investigated seven different process configurations for integration of a black liquor and biomass gasification plant with a Kraft pulp mill. Three different biofuels were investigated, Fisher-Tropsch liquids, dimethyl ether (DME) and ethanol rich mixed-alcohols. Their results show that the liquid fuel yield per unit of biomass is far higher for an integrated gasification plant than for a stand-alone gasification-based biorefinery. Furthermore, due to the integration between the biorefinery and the pulp mill, the specific capital investment cost is lowered to a level of \$ 60,000-150,000 per barrel of diesel equivalent capacity per day, which is comparable to much larger coal-to-liquids facilities.

Arvidsson et al. (2015a) studied opportunities for integrating a direct blown, pressurized, CFB gasification plant for production of olefins in a steam cracker plant. An integrated plant producing bio-methanol through gasification on-site, was compared to importing bio-methanol to the process. The methanol is used to produce olefins at the site and heat integration is performed through a heat recovery steam cycle (HRSC), generating electricity. The results show that the first option can lower the carbon footprint of the process by approximately 70% compared to a 50% decrease for the second case. Holmgren. et al. (2015) compared process integration for different gasification-based biorefineries in a case study. Comparisons were made to stand-alone units and results presented in terms of carbon footprint and net annual profit (NAP). The results indicate that integration with an industrial plant has positive impact on both carbon footprint and NAP for all scenarios. The fuel production cost is reduced by 7–8% if methanol is the end-product and by 12–13% if Fischer Tropsch diesel is produced.

The literature includes many studies that have investigated process design and optimization of gasification processes for biomethane production. Likewise, there are a number of papers presenting system studies of large-scale implementation of biomethane as a fuel. However, even though integration of gasification-based production of biomethane fuel at a sawmill site has been investigated in a few previous studies, research is lacking on the value chain performance of such a concept, as well as a thorough investigation of the possible benefits of liquefying the biomethane fuel product. Similarly, no previous work has been found that investigates how the selected size of an LBG gasification process in relation to the sawmill size affects the economic and carbon footprint performance of the entire value chain. If considering large scale implementation of biofuel production integrated with existing industrial plants, it is important to study the entire value chain to capture the effect of process integration on e.g. process size as well as transportation distances of the raw material and products, all affecting total cost and carbon footprint performance.

### 2.5 Biofuel value chains

Besides choice of conversion technology, plant design and process integration opportunities, the well-to-wheel value chain of biofuel generation is vital to achieve cost-effective processes with a low carbon footprint. The net carbon footprint associated with production of a specific biofuel type is affected by the type of fuel it is assumed to replace and, moreover, by the alternative use of the biomass used to produce the fuel. It has also been highlighted that to fully assess the performance of emerging technologies, it is important to assess their production and use in a relevant future background system (Arvidsson et al., 2017). A suitable approach is to use scenario-based analysis in which consistent assumptions regarding the surrounding system are used (Axelsson et al., 2009).

A variety of design variables affect the economic performance of a biorefinery, e.g. the choice of conversion technology, localization, feedstock, and final product(s). These aspects are often included in assessments conducted using supply chain optimization models, see e.g. Hosseini and Shah (2011), Ng and Maravelias (2017) or Čuček et al. (2012). Such models are used to identify biorefinery concepts, i.e. a specific combination of feedstock, conversion technology, final product(s), and optimal location, which minimizes the system costs for a given set of constraints (e.g., available feedstock, plant capacity etc.). Typically, transport costs are determined endogenously whereas biomass-to-product yields and feedstock prices are included as static input data (i.e. determined exogenously).

An additional decision parameter that has a large impact on the performance of a biorefinery concept is the scale of the production unit (see e.g. de Jong et al. (2017)). As a consequence of economies of scale, a large-scale plant has a lower specific capital cost per produced quantity of product. Conversely, large-scale units are penalized by longer distribution distances for the products and a larger uptake area for the biomass feedstock. These aspects have a negative impact on economic performance. Since process heat integration is an important parameter in achieving efficient biorefinery units (see Section 2.4), this aspect should also be considered when sizing a biorefinery plant. It is also important to consider that the potential for heat integration depends on the type, size and location of a suitable host industrial plant.

### 2.6 Bark feedstock

Different types of feedstock have been considered for gasification, e.g. forest residues, demolition wood, pitch oil and bark. The latter feedstock is considered in this work (Paper III). Bark is a residue from sawmills, pulp mills and paper mills with characteristics (physical size, composition, ash and moisture content) that differ considerably from wood pellets and other forest residues. The particularly high content of ash and alkali in bark limits the maximum allowable temperature levels in combustion boilers. As a result, bark is not an attractive fuel for power plant boilers. Currently, bark is mainly used as boiler-fuel for producing process steam or hot water. Bark is produced year-round in steady quantities since forest industry plants operate independently of the season. During periods of low heat demand in industry and district heating systems, demand for bark is very limited. Due to the restricted uses of bark as a fuel, it has a low price compared to wood pellets (Hokkanen et al., 2012) whereby it is particularly interesting feedstock for large-scale gasification plants which can operate year-round.

## Background & Related Work

Furthermore, usage of bark as feedstock could lower the cost of producing biofuels and chemicals through gasification, thus increasing the biofuels competitiveness compared to fossil alternatives.

Bark gasification has previously been evaluated at several facilities. Bark pellets were tested as feedstock in the DFB gasifier in Güssing Austria (Wilk et al., 2011). The test results indicated equal or higher cold gas efficiency for bark pellets (0.6kw/kw feedstock) compared to the other feedstocks, but also higher levels of dust in the product gas, due to the higher quantities of ash in the bark. The total tar levels for bark pellets were shown to be slightly higher compared to the levels when using wood of similar particle size. It was concluded that bark pellets are a suitable feedstock for DFB gasification, but also that the product gas might require improvements of the downstream gas cleaning equipment.

Other types of gasifiers have also been operated using bark as feedstock. As mentioned in Section 2.2, the Värö 30 MW<sub>biomass</sub> air blown, CFB, gasifier was operated discontinuously from 1987 to 2014 with different feedstocks, including bark, to provide gaseous fuel to a lime kiln (Wadsborn et al., 2007). The process was operated using feedstock that was pre-dried at the plant site. Since air was used as gasification medium, the product gas had a low heating value (6-7 MJ/kg) (Waldheim, 2015) with a nitrogen content not suitable for use a feedstock in a downstream synthesis nit. Bark gasification has also been evaluated in the pressurized entrained flow, oxygen blown pilot plant in Piteå, Sweden (Ma et al., 2016). The Piteå plant produced a syngas with a lower heating value of 7.82 MJ/kg dry feedstock, which is very similar to the values achieved in the same plant using stem wood (7.7 MJ/kg dry feedstock) (Weiland et al., 2012). Steam-oxygen gasification of bark was evaluated in an experimental, direct blown, pressurized, CFB gasifier by Kurkela et al. (Kurkela et al., 2016). The study evaluated bark dried with a moisture content of 12.2%<sub>w.b.</sub> for a test period of 215 hours and showed that stable and consistent operating of the gasifier with bark is possible. Furthermore, the test results did not indicate any bed material sintering, or problems with ash deposits and soot formation in the tar and CH<sub>4</sub> reformer.

There are some published results regarding usage of feedstock with heterogeneous characteristics for DFB gasification. However, most research has focused on modeling and experiments at research facilities or small-scale pilot plants. Some large-scale gasification plants have been operated with forest residues and residual waste. However, to my knowledge, such plants have always been based on direct, air blown, technology. Additionally, the gas has been used directly for combustion, putting lower demands on gas quality than if the gas is to be utilized for downstream synthesis purposes. Hence, there is a lack of research on conversion of feedstocks regarded as particularly complex (e.g. bark), in large scale DFB gasifiers with the purpose of synthesizing biofuels.





The gas produced in the gasifier (hereinafter referred to as raw gas) consists of a mixture of steam, H<sub>2</sub>, CO, CO<sub>2</sub>, CH<sub>4</sub>, C<sub>2</sub>H<sub>x</sub>, C<sub>3</sub>H<sub>x</sub>, C<sub>4</sub>H<sub>x</sub>, and aromatic as well as polyaromatic hydrocarbons (tar). Due to the risk of fouling and clogging downstream equipment in the plant it is important to remove tar from the product gas.

Downstream of the DFB gasifier is a three-stage gas cleaning system that removes aromatic hydrocarbons, referred to as tars, upstream of the methane synthesis section (Alamia et al., 2017a). After the gasifier, the product gas is cooled to around 160°–240°C, before the particles are removed using a bag filter. Thereafter, the major part of large tar components (naphthalene and larger) are removed in the RME scrubber, and the remaining aromatic compounds, mainly Benzene, are removed through adsorption using activated carbon. The heavier tar and the RME flow are fed to the combustor, where their thermal energy is recovered by heating the bed material, while the components desorbed from the activated carbon are recovered in the convection path of the flue gas train, as they are combusted in the post-combustion chamber during regeneration of the carbon (Thunman et al., 2018). While the combustion of char, RME, and tar covers part of the heat demand in the process, in order to maintain and control the temperature, some of the product gas is recirculated and combusted.

### 3.1.2 Operation with bark feedstock

During an experimental campaign conducted in November 2016, shredded bark was tested as feedstock in the GoBiGas plant. In this work, the resulting performance is compared with that of wood pellets, previously evaluated by Alamia et al. (2017a). Both feedstocks are presented in Table 1. Shredded bark is a residue of the de-barking process of wood and is stored in piles outdoors, in general the moisture content is approximately 50%<sub>w.b.</sub> (Andersson et al., 2014). The bark used in this evaluation was pre-dried to a moisture content of 20%<sub>w.b.</sub> prior to delivery to the test facility. The bark was stored outdoors and due to rain, the moisture content increased, especially on the surface of the storage pile; the presented value is an average for each of three measurement days.

The nomenclature in Table 1 uses one letter to identify the type of feedstock, *B* for bark and *P* for pellets, and a number to indicate the moisture content level since this was the parameter that varied the most; e.g., *B25* stand for shredded bark 25%<sub>w.b.</sub> (wet basis) moisture content.

*Table 1. Feedstock composition of bark and wood pellets, presented in % of kg dry ash free fuel (DAF).*

	<b>B25</b>	<b>B30</b>	<b>B34</b>	<b>P8</b>	<b>Unit</b>
<b>Moisture</b>	25.2	30.2	33.7	8.1	% A.R <sup>2</sup>
<b>Ash<sup>1</sup></b>	2.1	2.4	2.3	0.3	% A.R
<b>Volatiles</b>	76.5	75.8	75.3	80.9	% DAF
<b>Char</b>	23.5	24.2	24.8	19.1	% DAF
<b>LHV</b>	20.3	19.8	20.7	18.8	MJ/kg DAF

<sup>1</sup> silicates not included

<sup>2</sup> As received

The composition of the bark mainly differs from that of wood chips in terms of the fraction of char and ash in the feedstock, which is higher and thus gives a lower volatile fraction.

## 3.2 Power-to-gas pathway

### 3.2.1 Direct blown gasification plant

In Paper II, the biomethane plant is assumed to adopt a direct, oxygen blown gasifier unit. The main reason is that direct blown gasifiers requires a flow of oxygen for the plant to produce a gas suitable for synthesis. The water electrolysis unit produces a clean stream of oxygen, which constitutes an additional benefit. Moreover, the concept of power-to-gas has already been assessed for integration with DFB gasification by others researchers at Chalmers University of Technology (see Section 2.3). Generation of results for a direct blown gasification plant could therefore be used in the future for comparison of the two concepts; suitably done through a superstructure optimization.

In this work, the direct blown gasifier was not rigorously modeled (based on kinetics); it was based on experimental data and models previously developed by Hannula and Kurkela (2012). An overview of the process is shown in Figure 4.

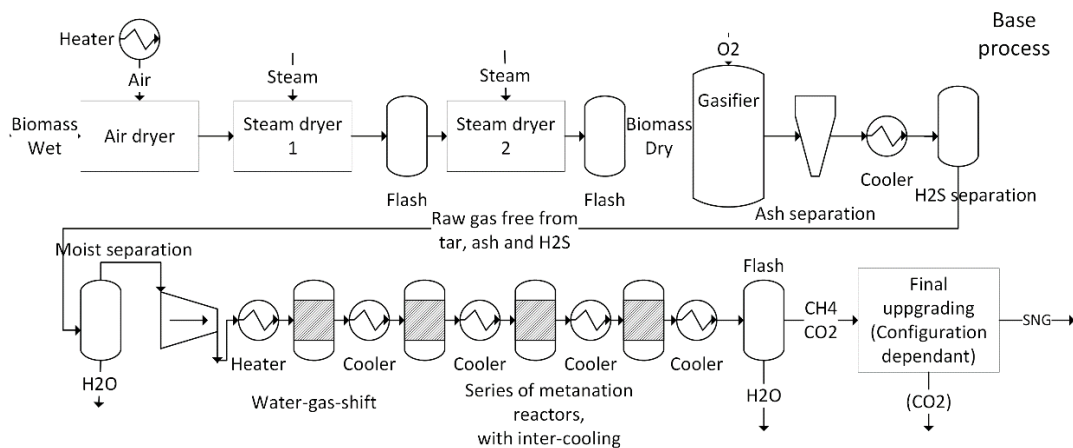

Figure 4. Overview flowchart of the direct gasification process used for the power-to-gas concept.

The raw gas leaving the gasifier contains  $\text{H}_2\text{O}$ ,  $\text{H}_2$ ,  $\text{CO}_2$ ,  $\text{CO}$ ,  $\text{CH}_4$ ,  $\text{H}_2\text{O}$ , inorganic impurities (e.g.  $\text{H}_2\text{S}$ ) and organic compounds such as tars. The ash and traces of char in the raw gas are removed in a cyclone, thereafter  $\text{H}_2\text{S}$  is removed. In a pre-methanation step, the ratio of  $\text{H}_2/\text{CO}$  is adjusted through the water-gas-shift reaction. The methanation reaction occurs in a series of three adiabatic, fixed bed, reactors. The gas is then cooled and remaining  $\text{H}_2\text{O}$  is removed through a flash reactor. Thereafter, the product gas contains solely  $\text{CO}_2$  and  $\text{CH}_4$ . The  $\text{CO}_2$  is removed or converted to  $\text{CH}_4$  in a final upgrading sequence, which is varied for four different process configurations.

### 3.2.2 Power-to-gas

Hydrogen from the electrolyser is used to produce methane through the Sabatier reaction with  $\text{CO}_2$ . Since  $\text{CO}_2$  is available in higher concentrations than in air, energy savings are achieved through this approach, whereas  $\text{O}_2$  can be used as a gasifying agent in the direct gasifier unit.

In this way, the product output of the process is enhanced while the energy loads of the air separation unit and the CO<sub>2</sub> separation sequence are decreased.

After the methanation section, the gas (containing only CH<sub>4</sub> and CO<sub>2</sub>) is fed into the final CO<sub>2</sub> removing sequence. Two specification values are considered for the Wobbe index of the biomethane product corresponding to the A and B standards of the Swedish national gas grid. The Wobbe index essentially limits the concentrations of both CO<sub>2</sub> and H<sub>2</sub> in the gas product. A-grade biomethane is produced if possible, since it can be sold at a higher price, otherwise B-grade biomethane is produced instead. Four possible configurations for the final CO<sub>2</sub> removal sequence and combination with the Sabatier process were investigated (see Figure 5):

- i. The gas from the methanation section is mixed with H<sub>2</sub> from the electrolyser and fed to the Sabatier reactor where H<sub>2</sub> reacts with CO<sub>2</sub> to increase the share of CH<sub>4</sub> in the gas. The gas is cleaned of the remaining CO<sub>2</sub> in a sequence of two amine-based CO<sub>2</sub> separators. The yield of the Sabatier reactor entails that there will be H<sub>2</sub> left in the gas after the reactor if all CO<sub>2</sub> is to be converted. Since configuration (i) does not include a H<sub>2</sub> separation sequence and the gas standards limits the concentration of H<sub>2</sub> in the gas product, there will always be CO<sub>2</sub> in the gas after the Sabatier reactor.
- ii. H<sub>2</sub> is added to the gas mix in sufficient quantity to convert all remaining CO<sub>2</sub>, thus removing the need for a CO<sub>2</sub> removal step. This configuration requires that the fraction of H<sub>2</sub> in the gas must be decreased, which is achieved with a H<sub>2</sub> separation unit. The separated H<sub>2</sub> is recirculated back to the mixing step before the Sabatier reactor.
- iii. CO<sub>2</sub> is separated from the product gas and mixed with H<sub>2</sub> in the Sabatier reactor. The produced gas, containing mainly CH<sub>4</sub> but also some remaining CO<sub>2</sub>, is dried and recirculated to the inlet gas stream before the CO<sub>2</sub> removal step.
- iv. Similar to Configuration (iii), with the difference that a H<sub>2</sub> separation step is added to the process after the drying step. This results in a process in which all the CO<sub>2</sub> in the raw gas can potentially be reacted to methane, since the excess H<sub>2</sub> can be removed.

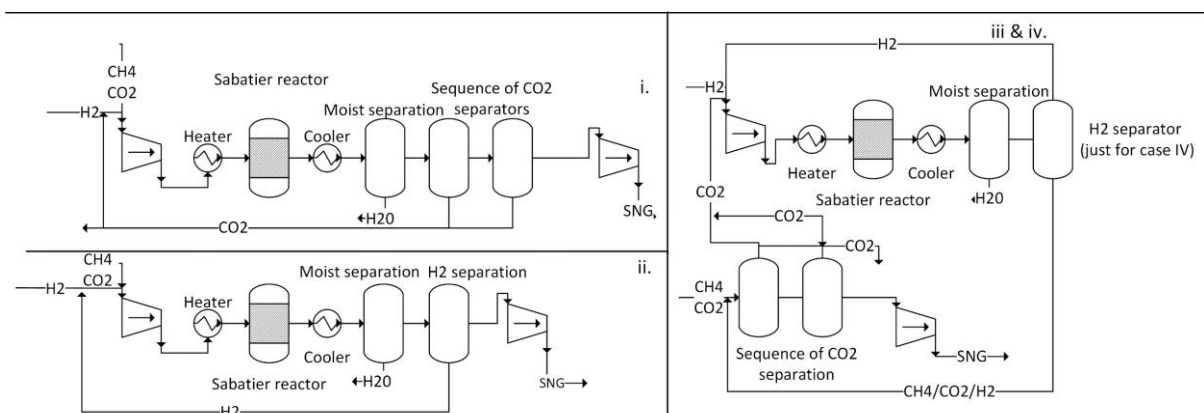

Figure 5. Overview of the final CO<sub>2</sub> removal sequence for the four configurations.

The main difference between the process configurations investigated is the degree of operational flexibility. Configuration (i) is limited by the fraction of CO<sub>2</sub> that can be reacted, since there will be H<sub>2</sub> in the produced gas if all CO<sub>2</sub> is reacted to methane. Configuration (ii) is limited by the absence of CO<sub>2</sub> separation units, meaning that the Sabatier reactor must always be fed with enough H<sub>2</sub> to achieve full conversion of the CO<sub>2</sub>. Thus configuration (i) is more flexible than configuration (ii). In configurations (iii) and (iv), the CO<sub>2</sub> is separated before it is reacted with the H<sub>2</sub>. Here configuration (iv) is the more flexible option; enough H<sub>2</sub> to react all CO<sub>2</sub> can be fed to the process, since a H<sub>2</sub> separation sequence is included.

Candidate electrolyser technologies include alkaline and Polymer Electrolyte Membrane (PEM) units (Brynnolf et al., 2018). PEM technology is characterized by a shorter start up time, but a lower efficiency. Alkaline electrolyser technology has reached a higher development level and was therefore selected for this work.

### 3.3 Process integrated value chain pathway

In Paper III, integration of a gasification-based biorefinery with a generic Nordic sawmill is investigated. The concept assumes that biomass residues are available in large quantities at sawmill sites, and takes into consideration that sawmills have a low-temperature heat demand for drying of sawn wood. By using the biomass residues as feedstock for a gasification plant, the excess heat from the process could be used in the sawmill process.

The data used in this study for estimating the energy balances of the biomethane production unit was extracted from simulations presented by Heyne (2013). The LBG process is assumed to adopt DFB gasification technology as demonstrated in the GoBiGas project. For a thorough review of the process, refer to Paper III. To increase the energy efficiency of the process, the heat flows are cascaded through an integrated heat recovery steam cycle (HRSC). The steam is used for electricity production in a back-pressure steam turbine with extraction ports at the pressure levels required to cover the process steam demands.

The integration of the gasification plant with the sawmill influences the performance of the total value chain. The size of the gasification plant determines the amount of excess heat that is available for integration with the sawmill and, conversely, the size of the sawmill determines the amount of residue feedstock that is available. If the gasification plant is significantly larger than the sawmill, the excess heat generated will exceed the heat demands of the sawmill and more condensing electricity will be generated. In addition, the feedstock requirements of the gasification plant will also exceed the by-product streams from the sawmill; additional feedstock will therefore need to be imported to the process. A large gasification process also entails longer transportation distances for the LBG product.

To investigate how these effects relate to the total GHG and economic performance of the integrated concept, the LBG plant is assumed to be sized according to five possible size-limiting factors:

- *Case 1 – Available sawmill residues.* The LBG plant is sized to use all available sawmill residues (sawdust, wood chips and bark) as feedstock.



## Chapter 4

### Methodology

The objective of this thesis is the assessment of different options to decrease the costs of biofuels produced in gasification-based biorefineries. The intended outcome of all pathways is increased cost efficiency. However, the measures required to achieve this goal may differ considerably, and thereby the research questions which must be answered as well. As discussed previously, different methods and perspectives are required to perform the evaluation (see Section 1.2).

Three different models were applied for the evaluations presented in this thesis. Figure 7 shows the system boundaries applied for the modeling of the different pathways.

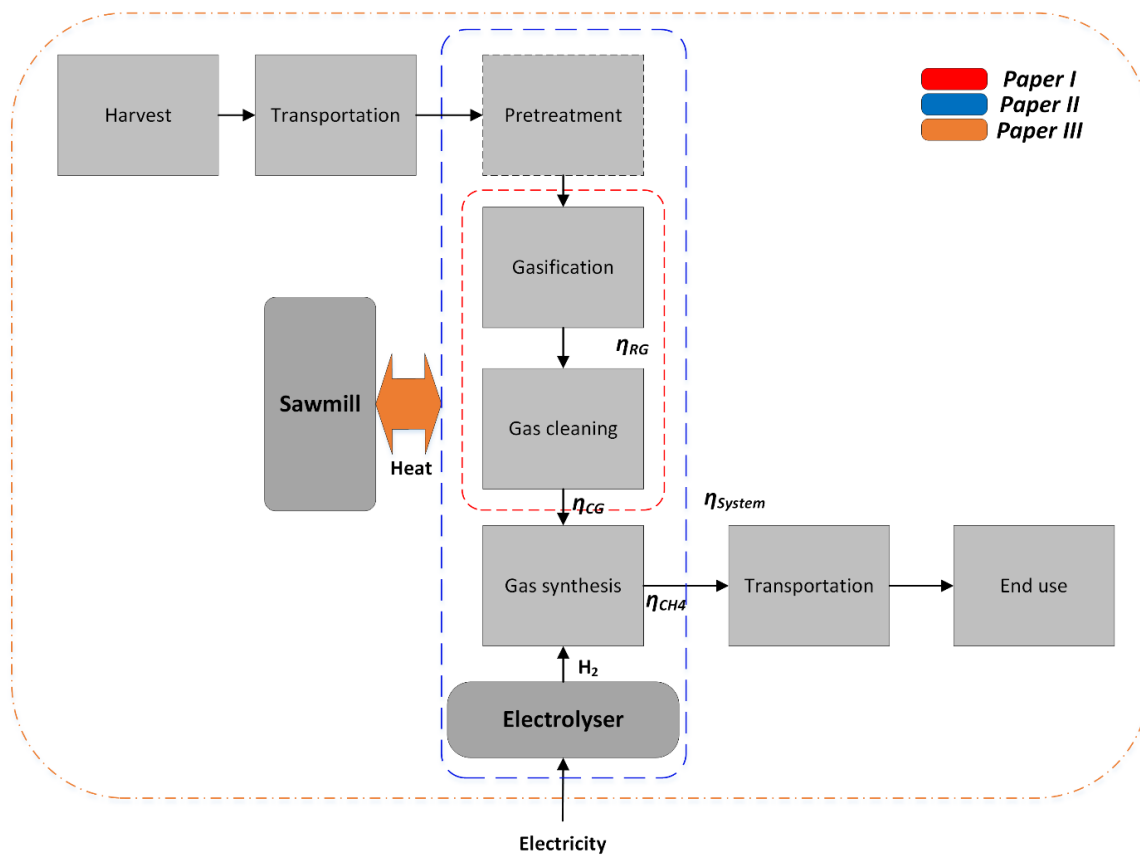

Figure 7. Model system boundaries with main energy and mass flows.

In Paper I, the system boundary of the applied model is drawn around the gasifier and subsequent gas cleaning steps, as displayed by the red dotted line in Figure 7. The performance of the overall plant is estimated based on additional assumptions. To quantify the differences occurring when switching feedstock in a gasifier, it is necessary to determine if it is possible to operate the process in the long run, to quantify the performance and to determine how it can be improved. Evaluation of the technical performance of the process is thus essential. To enable such assessment a detailed modeling approach is necessary. The modelling is performed applying a stochastic approach to reduce the uncertainty of the gasifier's energy and mass

balance, based on large sets of measured data from testing campaigns. Thereafter, a technically detailed model allows for calculation of how the operation of the plant changes for different fuel characteristics and enables accurate estimation of performance. All modeling was performed using Matlab.

In Paper II, the aim was to evaluate the most efficient process configuration for integration of hydrogen to the gasification-based biofuel plant. A wider perspective was therefore required. As displayed by the blue dotted line in Figure 7, the entire plant, from pre-treatment and drying to finished product, was modeled using Aspen Plus process simulation software (v. 8.8).

In Paper III, the aim was to evaluate how the sizing of a gasification plant integrated with a sawmill relates to the performance of the entire value chain. For this purpose, a full value chain model was developed, as displayed in Figure 7. The model includes feedstock transportation, the gasification-based LBG plant, the sawmill and distribution of the LBG product. Technical data generated by process simulation in Aspen Plus (v. 8.8), was used to represent the gasification-based plant and a Matlab sub-model was used to optimize the process integration between the two processes. The software ArcGIS (esri, 2018) was used to map the sawmills in Sweden and estimate transportation distances for the LBG product.

A short summary of the different models applied and the main methods they are based on are presented in the following sections, together with the key performance indicators (KPIs) applied in this work.

### 4.1 Bark feedstock pathway

#### 4.1.1 Stochastic model

The modeling in Paper I is based on data generated through a measurement campaign performed at the GoBiGas plant during ten days in November 2016. To evaluate the data, a method presented by Alamia et al. (2016b) was applied. The method was used in earlier work for evaluation of performance of the GoBiGas plant operating with wood pellets. The corresponding results constitute the reference case in the comparison made in Paper I. The model was developed in MATLAB. To enable economic performance evaluation for operation with bark feedstock with the same moisture content as pellets, a performance extrapolation model was developed for Paper I. An overview of the performance evaluation calculation procedure used in Paper I is presented in Figure 8.



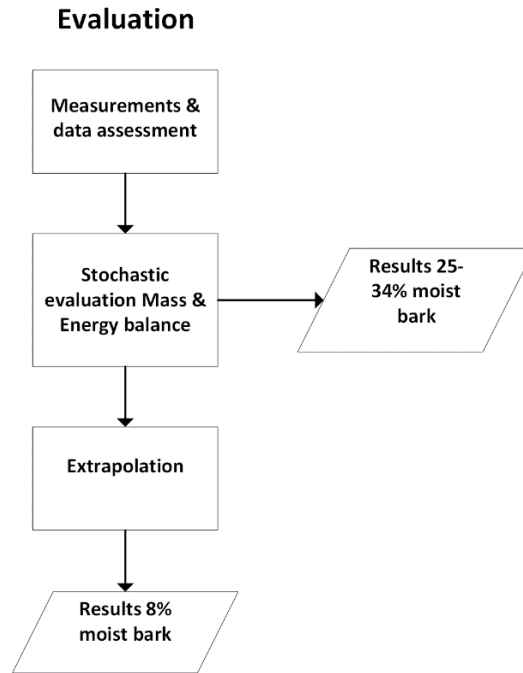

Figure 8. Overview of the calculation procedure

The set of measurements from a bark gasification campaign conducted at the GoBiGas plant constitutes the inputs to the mass and energy balance model. The biomass conversion is described through a black box modeling approach.

Mean values as well as standard deviation values are first calculated for the measurement data for the process streams indicated in Figure 3. This data is used to calculate the mass and energy balances for the complete gasification section of the DFB system. Due to different time resolution of the measurements, operation variation during the sampling period and fluctuation in the feedstock properties, there is uncertainty in the solution of the mass and energy balances. To decrease the impact of these uncertainties, a stochastic approach was applied (Metropolis and Ulam, 1949). All the input parameter values are varied stochastically within their standard deviation range for 1 000 000 calculations of the energy and mass balance. The cases that are not physically possible are discarded. The sets of parameter values that satisfy the material and energy balance constraints are retained, and all process stream data (mean value and the standard deviation) can thereafter be calculated. Finally, the performance indicators are calculated. For a thorough description of the model refer to Paper I or Alamia et al. (2016b)

#### 4.1.2 DFB gasifier performance extrapolation algorithm

During the measurement campaign, bark with a moisture content ranging from 25%<sub>w.b</sub> to 34%<sub>w.b</sub> was used as gasifier feedstock. To estimate the performance of the DFB operating with a moisture content outside of this range, an extrapolation algorithm was developed for Paper I, also using MATLAB. The results from the stochastic data evaluation model constitute the input data to the extrapolation algorithm.

The extrapolation algorithm is based on the same equations used for the mass and energy balance model and aims to predict process operating data for operating conditions outside of

the range of conditions corresponding to the measurement campaign. The algorithm can handle variation of several operating parameters simultaneously and recalculates the energy and mass balance of the system. In this study, only the effect of drying is investigated, by calculating performance for a moisture content of the bark feedstock of 8%<sub>w.b.</sub> (same as pellets). The calculated performance can then be compared with the performance for operation with wood pellets with the same moisture content. For a thorough description of the extrapolation algorithm and the assumptions it is based on, see Paper I.

## 4.2 Power-to-gas pathway

### 4.2.1 Power-to-gas process model

To assess the possibilities of utilizing hydrogen in a direct blown gasification process, four different process configurations were identified and modeled (see Section 3.2.2). All modeling in Paper II was performed using the process simulation tool Aspen Plus (v 8.8). The process equipment of the gasification process was in general not rigorously modeled (based on kinetics), with the exception of the methanation section. The Sabatier reactor is modeled as a plug flow reactor with Langmuir-Hinshelwood-Hougen-Watsonis kinetics, as described by Schlereth (2015). Process stream heating and cooling requirements were used to perform heat recovery targeting calculations using pinch analysis (see Section 4.3).

To capture the impact of varying hydrogen availability, sensitivity analysis varying the feed of H<sub>2</sub>, together with the recirculation of CO<sub>2</sub> is performed for all configurations except (ii), in which the H<sub>2</sub> flow is constant since the process is designed to react all CO<sub>2</sub> available in the gas.

## 4.3 Process integration

The value chain consisting of a liquefied biomethane plant based on DFB gasification technology integrated with a generic Nordic sawmill was evaluated in Paper III. The idea of co-locating the plant with a sawmill builds on the concept of process integration. According to the IEA process integration is defined as “Systematic and general method’s for designing integrated production systems...” (Gundersen, 2002). In Paper III, two aspects of process integration are considered, namely material integration and heat integration. Process integration is also applied in Paper II. However, only heat integration was considered.

Material integration implies that residues produced at the plant site can be utilized as feedstock in another process co-located at the same site, thereby reducing feedstock transportation requirements. If a gasification-based LBG plant is integrated at a sawmill site, the residues from the sawmill (bark, saw dust and wood chips), can be used as feedstock to the gasifier.

Heat integration implies that heat is cascaded between two processes with the aim of creating an integrated heat system in which the total energy utility requirements are lower than they would be for two stand-alone processes. To assess the opportunities for heat integration, pinch analysis tools can be used (as described for example in Kemp (2011)). Heat integration is not limited to heat transfer between different processes, but can also be applied to evaluate how heat can be recovered efficiently within a given process (Paper II). Pinch analysis provides a structured way for the user to determine the maximum level of heat recovery that can be achieved within the process, as well as the minimum hot and cold utility requirements.

As stated in Section 3.3, the heat flows of the integrated process are cascaded through an integrated steam cycle in order to co-generate a maximum amount of electricity. The back-pressure steam cycle is assumed to be equipped with extraction ports at the pressure levels required to cover the process steam demands. To assess the possible electricity production in Paper III, a linear optimization tool developed by Morandin et al. (2011) was used. The tool is used to construct the foreground curve of a HRSC, for a back-pressure turbine with five extraction ports, in relation to the background GCC of the integrated sawmill-LBG process. The objective of this approach is to simultaneously maximize the electricity production and the LBG production for a given size of sawmill.

### 4.4 Process integrated value chain pathway

#### 4.4.1 Value chain model

To relate the heat and material integration benefits to the performance of the entire value chain, scenario analysis was applied. Five different scenarios were considered for possible sizing of the LBG plant with respect to the sawmill, for two different sawmill sizes. The size of the sawmill determines the quantity of biomass residues that are available as feedstock for the gasifier. However, for some of the LBG plant sizes considered, additional feedstock is required. For these cases, the cost of transporting the feedstock to the plant must be considered. Furthermore, the size of the LBG plant determines the distance the LBG product must be transported.

The results presented focus on the relative differences between key performance indicators for the LBG production process integrated with a sawmill and a reference system consisting of the same generic sawmill (as defined in Anderson and Toffolo (2013)) without LBG production. Figure 9a) shows the reference system value chain together with the studied LBG system (Figure 9b)), including the relevant system boundaries considered in this work.

## Methodology

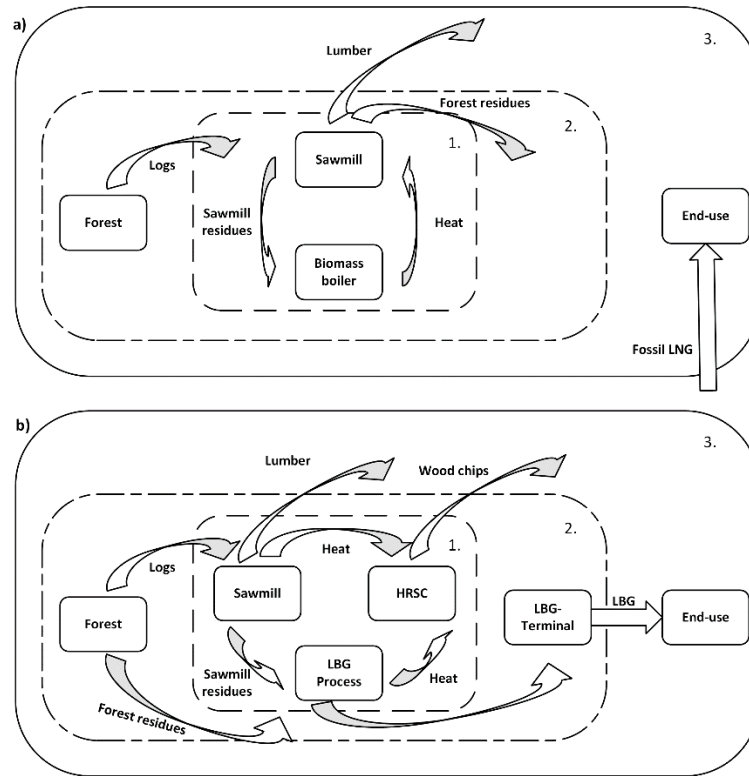

Figure 9. Sawmill integrated system and reference system.

The inner dashed square, marked 1 in Figure 9 b), corresponds to the boundary of the system consisting of an LBG process heat integrated with a sawmill heat through a heat recovery steam cycle (HRSC). The integrated process differs from the sawmill in the reference system (Figure 9 a)) in which the heating needs are satisfied through combustion of a fraction of the available sawmill residues in a biomass boiler. In the reference system, the sawmill residues not required for heat generation are sold, instead of being used as feedstock for LBG production.

To assess the uptake area for biomass, statistics from the Swedish board of forestry were used (Christiansen, 2014). ArcGis software (esri, 2018) as used to estimate the transportation distance of the finished product by mapping all LNG terminals and sawmills in Sweden and calculating an average distance depending on sawmill size. A model relating the electricity co-generated in the HRSC, the uptake area for biomass and the transportation distance for the product was developed using Microsoft Excel.

## 4.5 Key performance indicators

### 4.5.1 Thermodynamic indicators

To quantify the performance of the assessed pathways in Papers I and II, a number of thermodynamic KPIs were used, presented in Table 2.

Table 2. Process efficiency performance indicators

Char gasification	$X_g = \frac{n_{C,rg} - n_{C,v}}{n_{C,ch}}$	(1)
Bed material oxygen transport	$\lambda_{Otr} = \frac{n_{Otr}}{n_{O,f}}$	(2)
Product gas recirculation	$PG_{rec} = f_{rec} * \frac{\sum_{i=1}^{Gas+PAHs} n_i * LHV_i}{LHV_f}$	(3)
Raw gas efficiency	$\eta_{RG} = \frac{\sum_{i=1}^{Gas+PAHs} n_i * LHV_i}{LHV_f}$	(4)
Cold gas efficiency	$\eta_{CG} = \frac{\sum_{i=1}^{Gas} n_i * LHV_i}{LHV_f}$	(5)
Biomethane efficiency	$\eta_{CH_4} = \frac{n_{CH_4} LHV_{CH_4}}{LHV_f}$	(6)
System energy efficiency	$\eta_{system} = \frac{\sum \dot{m}_p LHV_p + Q_- + E_-}{\sum \dot{m}_f LHV_f + Q_+ + E_+}$	(7)

$n_{C,rg}$  is the carbon content of the raw gas,  $n_{C,v}$  is the carbon content in the volatiles,  $n_{C,ch}$  is the carbon in the char,  $n_{O,f}$  is the total oxygen supply to the combustor,  $n_i$  is the number of moles of the i-th compound in the raw gas,  $f$  denotes feedstock,  $f_{rec}$ , denotes the fraction of raw gas recirculated to the boiler and  $Otr$  denotes oxygen transport with the bed material.  $\dot{m}$  indicates the mass flow of either product, p, or of fuel, f. Q denotes heat and E electricity, - and +, refer to energy flows leaving or entering the process.

Oxygen transport, product gas recirculation and char gasification all relate to the performance of the gasification process and are relevant for the performance calculations presented in Paper I. The char gasification,  $X_g$ , is defined as the fraction of the char that is gasified in relation to the total char content of the feedstock, this parameter assesses the extent of the biomass conversion based on the mass balance of the gasifier. Char gasification is of particular interest when using bark as feedstock, due to high char content. The parameter  $\lambda_{otr}$  expresses the oxygen transported from the combustion to the gasification reactor compared to the oxygen required for stoichiometric combustion of the feedstock.

To assess the overall performance, different efficiency indicators were applied in Papers I and II. Figure 7 shows the system boundaries of the gasification process used for the efficiency indicators considered in Paper I. The efficiencies are used to quantify the conversion of feedstock to raw gas and cold gas. The raw gas efficiency  $\eta_{RG}$  quantifies the conversion of biomass in the gasification reactor and is calculated based on the energy content of the raw gas including all the PAHs and the product gas that is later recirculated. The cold gas efficiency  $\eta_{CG}$  is calculated from the product gas leaving the gasification section (after the carbon beds) and it captures the performance of the whole gasification section. To estimate the feedstock related cost (FRC), the economic performance indicator considered in Paper I, it is necessary to first calculate the biomethane efficiency, i.e. the amount of biomethane produced per biomass input ( $LHV_{daf}$ ). This is done according to Equation 6. The system boundary applied for the calculation of  $\eta_{CH_4}$  is also shown in Figure 7. Since only the gasification section is modeled in Paper I,  $\eta_{CH_4}$

## Methodology

is calculated assuming a conversion factor of cold gas to biomethane corresponding to maximum possible methanation. The system energy efficiency  $\eta_{system}$ , applied in Paper II relates the total energy input (LHV), in terms of biomass feedstock and electricity, to the total output from the process in terms of product and heat.

In Paper III, the results of the energy and mass balances are used together with the value chain transportation distance to calculate the carbon footprint for each of the value chain configurations. However, these results are only briefly described in the results presented in this Thesis. For a thorough description of the carbon footprint calculations refer to Paper III.

### 4.5.2 Economic performance indicators

Table 3 shows the different economic indicators used for evaluation and comparison between the different cases. In Paper I, the objective of the economic evaluation was to assess the economic incentive for switching from wood pellets to a less costly feedstock. Therefore, pellets and bark were compared by estimating the fuel related cost  $FRC$  (Equation 9), i.e. the cost of the feedstock per unit of biomethane produced. Differences in costs for the process in terms of e.g. process utilities when switching feedstock were not included. The results were also compared to the case of using forest residuals as feedstock. To enable a broader analysis, sensitivity analysis was performed by varying the price of the respective feedstock by  $\pm 15\%$  with respect to the nominal value.

In Paper II, the plant investment cost data was not available. The economic performance indicator was therefore the operating revenue  $OR$  (Equation 10), obtained by subtracting the cost of biomass feedstock and all utilities from the revenues of selling the biomethane product, process excess heat and the oxygen produced in the electrolyser.

In Paper III, the object was to fully assess the cost of generating LBG integrated with a sawmill. Therefore the fuel production cost ( $FPC$ ) [ $EUR/MWh_{product}$ ] was calculated (Equation 11). The cost is calculated per unit of produced fuel, including the plant investment cost and operational costs. It was assumed that the process has an annual operating time of 8000 hours.

Table 3. Economic performance indicators.

---

$$FRC = \frac{P_{feedstock}}{\eta_{CH_4}} \quad (9)$$

$$OR = \frac{(P_{biomethane} - \sum OC) Output_{biomethane}}{Output_{biomethane}} \quad (10)$$

$$FPC = \frac{TPI \cdot CRF + O\&M + I_{fr} P_{fr} + I_{tfr} P_{tfr} + O_d P_d + (I_{el} - O_{el}) P_{el} - O_{el} P_{el, cert} - O_{wc} P_{wc} + O_{BM, ref} P_{BM, ref}}{O_{LBG}} \quad (11)$$

---

The following nomenclature is used in the three economic performance indicators:

9. The  $FRC$  is calculated in  $EUR/MWh_{biomethane}$ .  $P_{feedstock}$  denotes the price of the feedstock, i.e. bark or wood pellets, in  $EUR$  per  $MWh_{LHV, daf}$  feedstock,  $\eta_{CH_4}$  denotes  $MWh$  of biomethane in the biomethane product per  $MWh_{daf}$  feedstock.

## Methodology

10. The  $OR$  is calculated as  $USD/MWh_{\text{biomethane}}$ .  $P_{\text{biomethane}}$  denotes the sales price of biomethane and  $OC$  the operational costs, e.g. the cost of electricity, catalyst etc. both in  $USD/MWh_{\text{biomethane}}$ .  $Output$  indicates the net output of biomethane, expressed in  $MWh_{\text{biomethane}}$
11. The  $FPC$  is calculated in  $EUR/MWh_{\text{LBG}}$   $I$  indicates flows into the system and  $O$  indicates flows leaving the system, expressed in  $MWh/yr$ .  $O\&M$  denotes operation and maintenance costs in  $EUR/yr$ .  $P_i$  denotes prices in  $EUR/MWh$ . The subscript  $fr$  indicates forest residues,  $tfr$  transportation of forest residues,  $d$  distribution cost of LBG,  $el$  electricity,  $el,cert$  electricity certificates (Swedish support system for renewable electricity production),  $sr$  sawmill residues,  $wc$  wood chips. All costs are related to the reference sawmill where the biomass residues are sold. This means that the lost income from the biomass residues, which could have been sold in a stand-alone sawmill, are added to the total cost. The biomass residues are denoted  $Bmref$ .  $TPI$  denotes the total plant investment cost (see Section 3.6.1).  $CRF$  denotes the capital recovery factor (or annuity factor), set to 0.1 (which for example corresponds to an economic lifetime of 20 years and a discount rate of 8%, which are typical values adopted for assessing strategic investments in industry).

## Methodology



# Chapter 5

## Results & Discussion

Chapter 5 presents a selection of the most relevant results from the appended papers.

### 5.1 Bark feedstock pathway

In Paper I, the specific aim was to evaluate operation of a DFB gasifier with shredded bark. The results were compared to operation with regular wood pellets in terms of operability, efficiency and economic performance.

#### 5.1.1 Mass and energy balances

Perhaps the most significant result related to the feedstock switch from wood pellets to shredded bark, is that it was possible to consistently operate the process under stable and safe conditions. The GoBiGas gasifier was operated with shredded bark as feedstock for more than 750 hours during March 2018. No significant sintering or agglomeration problems related to the use of bark could be detected during this period.

The mass and energy balances of the process are reported in Table 4. The applied KPIs are described in Section 4.5.1. *B* stands for bark, *P* for pellets and the number indicates the moisture content on a wet basis, i.e. *B25* stands for bark with 25% moisture content; *SD* is the standard deviation.

*Table 4. Process performance indicators for all cases and for the extrapolation (see Section 4.5.1)*

<b>Results</b>	<b>B25</b>	<b>SD</b>	<b>B30</b>	<b>SD</b>	<b>B34</b>	<b>SD</b>	<b>P8</b>	<b>SD</b>	<b>B8 (Fig 8)</b>	<b>Unit</b>
<b>Feedstock flow</b>	5109	183	4894	212	5043	344	5820	366	5109	kg a.r./h
<b>Feedstock load</b>	0.65	-	0.57	-	0.58	-	0.87	-	0.65	% of full load
<b><math>\eta_{CG}</math></b>	0.55	0.02	0.49	0.03	0.5	0.04	0.72	0.04	0.65	-
<b><math>\eta_{RG}</math></b>	0.78	0.04	0.74	0.04	0.74	0.06	0.87	0.05	0.78	-
<b><math>\eta_{CH_4}</math></b>	0.47	0.02	0.42	0.02	0.43	0.03	0.61	0.03	55.7	-
<b>PG rec</b>	0.15	0.04	0.20	0.03	0.19	0.07	0.08	0.005	0.04	MJ/MJ daf % of total
<b>Xg</b>	0.45	0.08	0.37	0.08	0.4	0.12	0.54	0.12	0.45	char
<b>iHD</b>	3.9	0.3	4.4	0.4	4.8	0.5	1.8	0.3	2.45	MJ/kg daf
<b><math>\lambda_{Otr}</math></b>	10	4.7	9.5	4.6	4.8	4.8	4.9	2.7	10	mass %
<b>Heat loss gasifier</b>	0.70	0.37	0.71	0.17	0.58	0.20	0.78	0.41	0.70	MW
<b>Heat loss combustor</b>	1.92	0.13	1.96	0.48	1.60	0.54	2.15	1.13	1.92	MW

## Results & Discussion

A major difference between bark and wood pellets is the influence of the char gasification on the raw gas efficiency ( $\eta_{RG}$ ). Due to the higher fractions of char and ash in the bark feedstock, there are less volatiles that are converted to raw gas. Hence, the raw gas efficiency has a larger dependency on the char gasification. The lower extent of char gasification leads to a raw gas efficiency for bark that is around 5 percentage points lower than for pellets.

The cold gas efficiency ( $\eta_{CG}$ ) values for all bark cases are low compared to pellets. Pellets achieve a cold gas efficiency of approximately 70%, whereas the bark cases achieve cold gas efficiency values in the range 50-55%. As expected, the cold gas efficiency for bark is strongly affected by the high moisture content, which leads to a significant energy penalty for the feedstock drying. The main consequence of the higher moisture content is increased product gas recirculation.

The higher product gas recirculation explains why the difference in raw gas efficiency is smaller than the difference in cold gas efficiency between the bark cases and pellets. However, the difference in cold gas efficiency between the two feedstocks does not necessarily hold if the bark is dried to the same moisture content as the pellets. The relationship between cold gas and raw gas efficiency is dependent on the quantity of tar in the raw gas and on the product gas recirculation. When the moisture content is lower, the internal heating demand (iHD) of the gasifier is decreased, mainly due to a decrease of heat required for evaporation of the moisture in the feedstock. A decrease in iHD means that a lower share of product gas is required to the combustor, which increases the cold gas efficiency.

### 5.1.2 Extrapolation and economic results

The measurements for the B25 case were used as input data for the extrapolation algorithm, so as to predict performance for a moisture content of 8%, i.e. the same value as the wood pellets. The results of the extrapolation algorithm are presented in the last column of Table 4 (case B8) where they can be compared to the results from the mass and energy balances based on experiments. Figure 10 displays the most important process indicators for case B25 and case B8 in comparison to wood pellets (P8).

## Results & Discussion

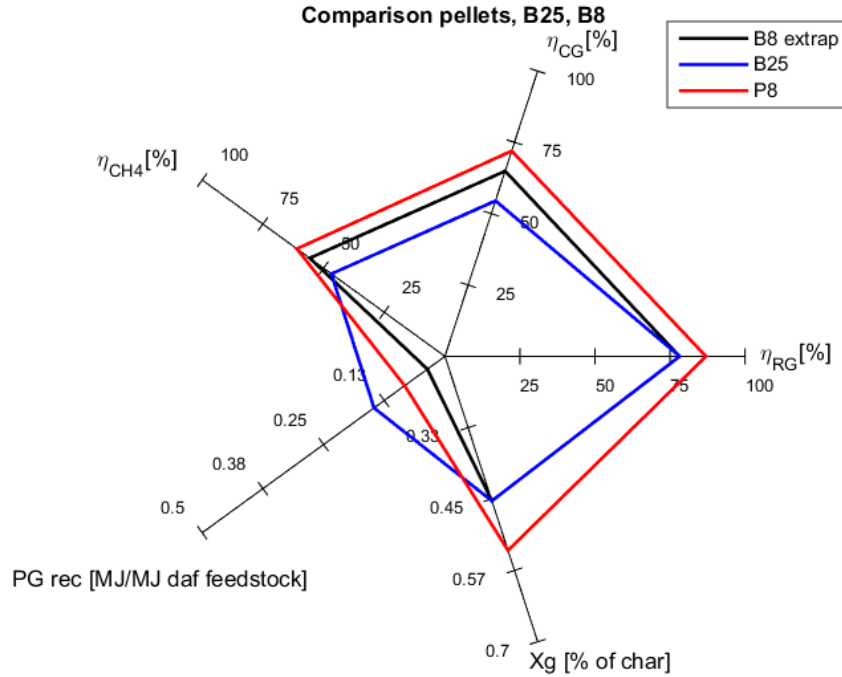

Figure 10. Spider plot presenting the cold gas, raw gas and methane efficiencies together with the char gasification and product gas recirculation (see Section 4.5.1) for case B25, and the reference wood pellets case (P8).

Figure 10 shows how the shape of the plots of the B25 case results changes to resemble that of the P8 case, when the moisture content is lowered (B8 extrap). By lowering the product gas recirculation, it is possible to push the cold gas efficiency and  $CH_4$  efficiency values for bark operation, towards the levels corresponding to operation with wood pellets (65% for 8% m.c. bark, 72% for wood pellets), naturally also increasing the biomethane efficiency (56 for 8% m.c. bark, 61% for wood pellets).

One of the reasons that makes it possible to lower the product gas recirculation ( $\eta_{RG}$ ) more for bark than for wood pellets is the higher levels of tar going to the combustor. However, the main reason is that there is more char being sent to the combustor as a result of both higher char content and lower char gasification. Since the char gasification is assumed constant for the extrapolated B8 and the original B25 cases,  $\eta_{RG}$  remains at the same level.

It should also be mentioned that for a commercial scale plant (larger than 100 MW), the losses from the process are likely to decrease, resulting in higher efficiencies. Alamia (2016) showed that it should be possible to increase the biomethane efficiency up to 70-75% LHV<sub>daf</sub> for an optimized large scale plant operating with dried bark feedstock (3% - 8% w.b.), i.e. a potential increase of 15%-points compared to the results presented here. There is no reason that a large-scale plant operating with dried bark as feedstock would not show a similar trend.

The results from the extrapolation performance calculations show that the gasifier can achieve a similar biomethane efficiency for different feedstocks if the moisture levels are the same. Roughly, the feedstock-related cost (EUR/MWh<sub>biomethane,LHV</sub>) could therefore be approximated

## Results & Discussion

by linear correlation with the feedstock price (EUR/MWh<sub>DRY,LHV</sub>), depending on the biomethane efficiency (Figure 8a) or moisture content (Figure 8b).

The results of the sensitivity analysis with respect to feedstock price ( $\pm 15\%$  with respect to the base case price) are shown in Figure 11a. The results are produced using the original data for bark from case B25 and the results obtained when extrapolating the results of B25 to 8%<sub>w.b.</sub> moisture content, extrapolated to the costs of forest residuals and wood pellets. The feedstock cost is given per MWh dry, ash-free, biomass. Figure 11b indicates how *FRC* varies for a commercial-scale, optimized plant with different biomethane efficiencies. The difference in performance between Figure 11 a) and b) illustrates the potential increase of economic performance that could be achieved for a commercial plant compared to the GoBiGas demonstration plant.

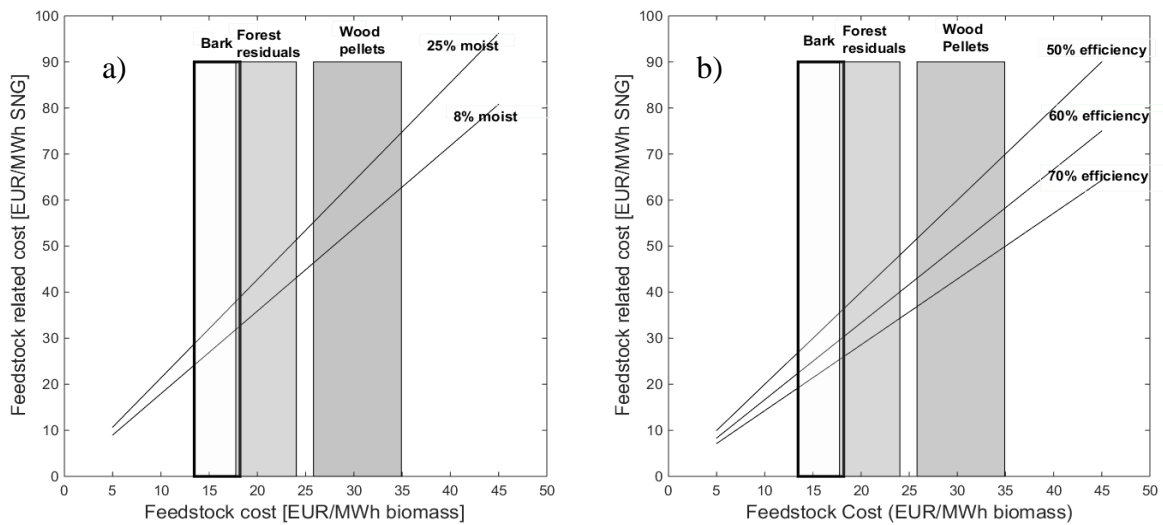

Figure 11. Economic sensitivity analysis (see equation 9).

As shown in Figure 11, the cost of the bark feedstock per MWh of biomethane product is lower than that of wood pellets, even if a feedstock with 25%<sub>w.b.</sub> moisture content is used. Thus, the feedstock-related cost for bark is always lower than for pellets, regardless of the moisture content. The same conclusion can also be reached for operation with forest residuals. This is because the price of wood pellets is much higher than the prices of forest residuals and bark.

The cost of producing biomethane can be decreased by 13.5-18.3 EUR/MWh biomethane solely by switching feedstock to bark with 25%<sub>w.b.</sub> moisture content corresponding to an overall decrease of approximately 32%. However, if the feedstock is dried to 8% moisture content, the production cost is lowered by an additional 18.1-24.6 EUR/MWh biomethane or 42%. Using dried forest residues results in approximately the same feedstock related cost as using bark with 25% moisture content. The results also show how the cost can be decreased to approximately 23-31 EUR/MWh biomethane, if the efficiency can be increased to 70%, which should be possible for a commercial-scale plant using a feedstock with 8% moisture (Alamia et al., 2017a). For a 100 MW plant, operating at 8000 hours a year, an annual net gain of 14.5-19.7

MEUR can be achieved if switching feedstock to dried (8%<sub>w.b.</sub>) shredded bark compared to using wood pellets.

## 5.2 Power-to-gas pathway

Paper II constitutes the first part in a larger assessment of integrating power-to-gas concepts with a direct blown biomass gasifier. The results compare 4 different process configurations in terms of system energy efficiency and operating revenues.

Three of the four process configurations (configurations (i), (iii) and (iv)) for the power-to-gas evaluations were subjected to sensitivity analysis, varying the amount of H<sub>2</sub> fed to the process. For configuration (ii), the H<sub>2</sub> flow is constant at 10 kmol/h, which is the flowrate required to convert all CO<sub>2</sub> in the gas mix. The results for both operating revenues (see Section 4.5.2) and system energy efficiency (Equation 7) are displayed in Figure 12 with system energy efficiency to the left and operating revenues to the right.

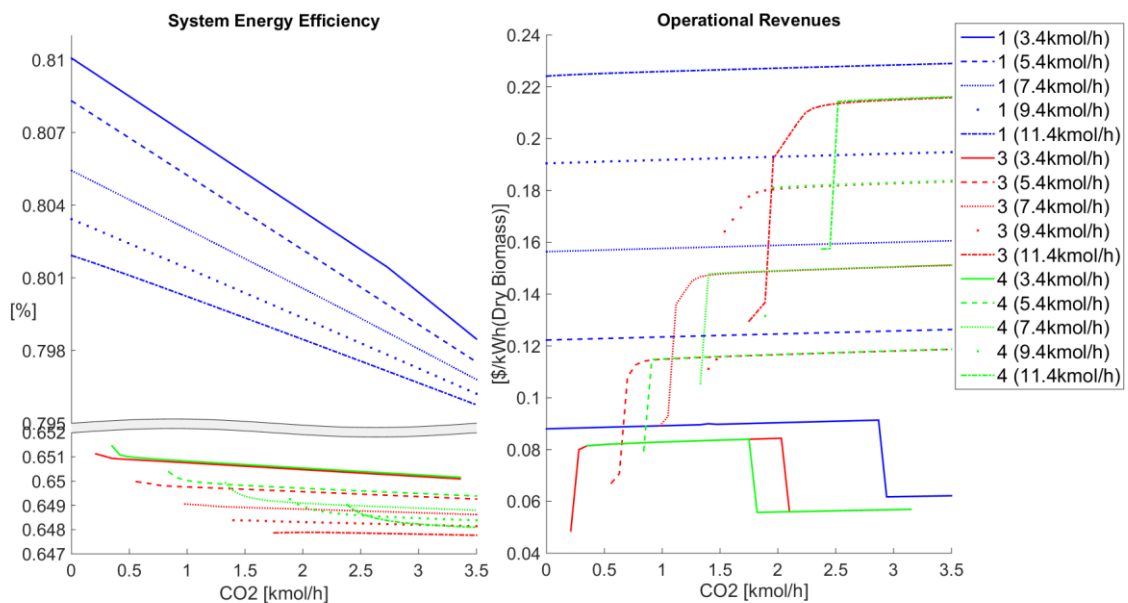

*Figure 12. Total system energy efficiency and operating revenues as a function of CO<sub>2</sub> feed. The line colors correspondent to different configurations and the line types correspond to the amounts of H<sub>2</sub> feed.*

The color of the lines corresponds to the different configurations and the line types indicate the amount of H<sub>2</sub> feed from the electrolyser to the system. The ranges of each curve indicate the cases where the produced gas fulfills the A or B Wobbe index standards the Swedish gas grid. As shown in Figure 12,  $\eta_{\text{system}}$  decreases with increased H<sub>2</sub> feed and CO<sub>2</sub> recirculation rate. This is due to the conversion losses in the electrolyser, implying that the larger the share of the total energy input that comes from electricity, the lower the system energy efficiency will be.

The process operating revenues increase for all configurations with H<sub>2</sub> feed and CO<sub>2</sub> recirculation. This indicates that the additional biomethane produced by the increased addition of H<sub>2</sub> outweighs the cost of generating the H<sub>2</sub>. The increase in revenues is essentially linear, except for some rapid increases and decreases in revenues. These rapid changes indicate the

thresholds for the types of biomethane produced, namely when the model has to change from production of grade A to grade B biomethane. Only configuration (i) has an increase in revenue that can be achieved without CO<sub>2</sub> recirculation, which is because there is already CO<sub>2</sub> present in the incoming gas flow. For configurations (iii) and (iv), a certain amount of CO<sub>2</sub> has to be recirculated to provide the second reactant to the Sabatier reactor.

Sensitivity analysis was not performed for configuration (ii), since the amount of hydrogen feed to the process is fixed. The system energy efficiency of configuration (ii) is 0.801 and the operating revenues are 0.245 \$/kWh<sub>dry biomass</sub>. Configuration (ii) results in the highest revenues and a high system energy efficiency, which is because all CO<sub>2</sub> in the raw gas is converted to CH<sub>4</sub>.

### 5.3 Process integrated value chain pathway

Paper III focused on assessing the value chain of integrating a DFB gasification plant producing liquefied biomethane with a sawmill. The results highlight both economic performance and total GHG emissions.

The GHG emission results show that regardless of the assumed sizing criterion for the LBG plant, the reduction potential of the carbon footprint from gasification based LBG production is significant, with essentially negligible emissions from most parts of the value chain compared to the offset emissions from replacing fossil LNG in end-use applications. The reduction potential varies between 175 and 250 kg CO<sub>2eq</sub> per net use of biomass, accounting for the difference in biomass use compared to a reference stand-alone sawmill scenario. The net electricity production causes the largest variation. Large LBG plants in, on relative terms, small sawmills were shown to result in heat mismatch and inefficient energy systems with condensing electricity production, resulting in lower carbon footprint reduction potential.

Under the following subheadings the economic results are presented together with the overall energy balance. For a through presentation of the GHG emissions results, refer to Paper III

#### 5.3.1 Energy balances

Figure 13 shows the grand composite curve (GCC) for Case 1 (Available sawmill residues, see Section 3.3) for a sawmill producing 50 000 m<sup>3</sup>/yr. Indications of the values of minimum temperature difference for heat exchanging ( $\Delta T_{\min}$ ) for different stream types are reported in Paper III.

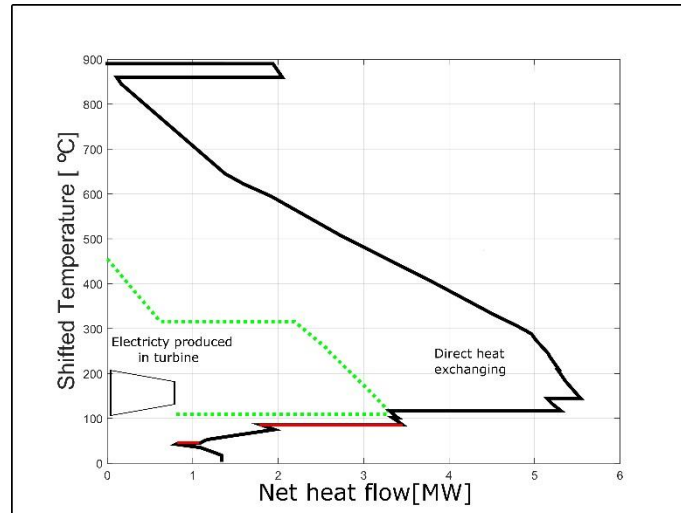

Figure 13. Grand composite curve of Case 1 for the 50 000 m<sup>3</sup>/yr<sup>3</sup> sawmill.

The background curve of the LBG process is represented by the black line, the heat requirements of the sawmill are represented by the red lines in the background curve and the green, dotted, foreground curve is the HRSC. The horizontal distance indicated by the steam turbine icon between the temperature axis and the end of the foreground curve indicates the target for maximum possible electricity production. The area under the background curve that is not covered by the foreground curve indicates that parts of the heat integration will occur through direct heat exchanging between hot and cold streams.

By studying the curve it can be noted that there is enough excess heat from the process to cover its heating needs; the excess heat from the LBG process is sufficient to cover the heating needs of both the LBG process and the sawmill for this case. However, as can be seen from the background curve, the excess heat from the integrated process is not enough to fully integrate the HRSC (dashed line), resulting in significant losses of exergy. This is because there is not enough surplus heat to raise steam with all available excess heat, and still cover the heating needs of the integrated process.

The resulting GCCs of the other four cases are presented in Paper III. When the background curve of the LBG process is dimensioned according to different criteria, the relative sizes of the heat flows between the sawmill and the LBG process change. A larger LBG process, in relation to the sawmill, entails that the HRSC can be more integrated, increasing the possible electricity generation. However, beyond a certain size, the LBG process becomes so much larger that if all excess heat is to be utilized, a condensing turbine section is required in the steam cycle, i.e. more heat is available from the LBG than required by the sawmill.

In Table 5 the resulting energy flows are presented for each case, together with the average transportation distance for forest residues and the total investment cost. The different sizing criteria are described in Section 3.3.

## Results & Discussion

*Table 5. Energy flows, feedstock transportation distances and total investment costs.*

Sawmill size /Case	Biomass from Sawmill [MW]	Imported Forest residues [MW]	Net biomass use [MW]	LBG produced [MW]	LBG produced per net biomass use	Power balance [MW]	FR trsp. distance [km]	Investment cost [MEUR]
<b>50 000 m<sup>3</sup></b>								
1	14.0	0.0	11.8	9.7	0.82	-0.7	0.0	41.2
2	7.0	0.0	4.7	3.9	0.83	0.5	0.0	31.1
3	14.0	10.0	21.8	16.7	0.77	-0.1	12.9	72.0
4	14.0	6.0	17.8	13.9	0.78	-0.1	10.2	63.1
5	14.0	706.1	717.8	500.0	0.7	5.9	110.6	796.0
<b>500 000 m<sup>3</sup></b>								
1	140.4	0.0	117.9	97.5	0.82	-7	0.0	221.6
2	69.6	0.0	47.2	38.6	0.83	5.0	0.0	151.2
3	140.4	99.8	217.7	166.8	0.77	-1	40.8	351.2
4	140.4	60.4	178.2	139.4	0.78	-1	32.4	306.1
5	140.4	579.7	697.6	500.0	0.72	3.7	100.3	810.3

Each case has a flow of forest residues coming from the sawmill and for some of the cases, additional forest residues are imported to the process. The total biomass required is the imported biomass plus the biomass residues from the sawmill and the net biomass use is the difference in used biomass compared to the reference sawmill case.

The degree of heat recovery is most efficient for Cases 2 (Available sawmill residues excluding wood chips) and 4 (Sawmill heat demand). In Case 2, export of a fraction of the biomass residues from the process entails that a part of the available bark and sawdust needs to be combusted to fulfill the heat demand; the heat available if all biomass is gasified is not enough to fulfill the heat demands of the sawmill. By burning parts of the biomass in a boiler, heat is released at a higher temperature, which means that the electricity generation becomes even more efficient. Therefore Case 2 results in an excess of electricity generated by the process. For Case 4, the steam cycle is by definition perfectly integrated (see Section 3.3). However, as high temperature heat from the furnace is not included, less electricity is generated, resulting in a small net electricity deficit for the process. This also results in a higher net biomass use in relation to the LBG produced for this case, as compared to Case 2.

Due to a poorly integrated steam cycle, Case 1 has a negative net power balance. However, even though the power balance is negative, the heat demand of the sawmill is satisfied relatively efficiently, and no resources are used for production of condensing electricity, which results in a high production of LBG per unit of biomass used. Case 3 (Forest residues uptake area) also has a net negative power balance. The import of additional feedstock leads to higher electricity production, however it also results in a relatively high net biomass use in relation to the amount of LBG produced.



## Results & Discussion

In Case 5 (Large scale), the LBG process produces large amounts of excess heat that is used for electricity production through a condensing turbine stage, due to sawmill heat demand mismatch. This means that the net electricity production for this case is positive. However, the positive aspects of the process integration are limited and the energy efficiency performance is poor, with a significantly higher net biomass use in relation to the produced LBG, at the same time as a lot of excess heat is used for inefficient power generation.

Since all flows are assumed to scale linearly when estimating the energy balances for the different cases, the dimensions of the fore- and background curves are exactly the same for all sawmill sizes, except for Case 5. For Case 5 the size of the sawmill, relative to the LBG process, changes between the cases. Thus, the electricity production per net amount of biomass differs between the sawmill sizes within Case 5.

### 5.3.2 Economic performance

Figure 14 presents the calculated fuel production cost for all cases. “Internal feedstock” denotes the incremental usage of sawmill by-products compared with the reference sawmill case, thereby constituting a cost (or a lost revenue from selling of the by-products). The external feedstock cost is the cost for purchased forest residues.

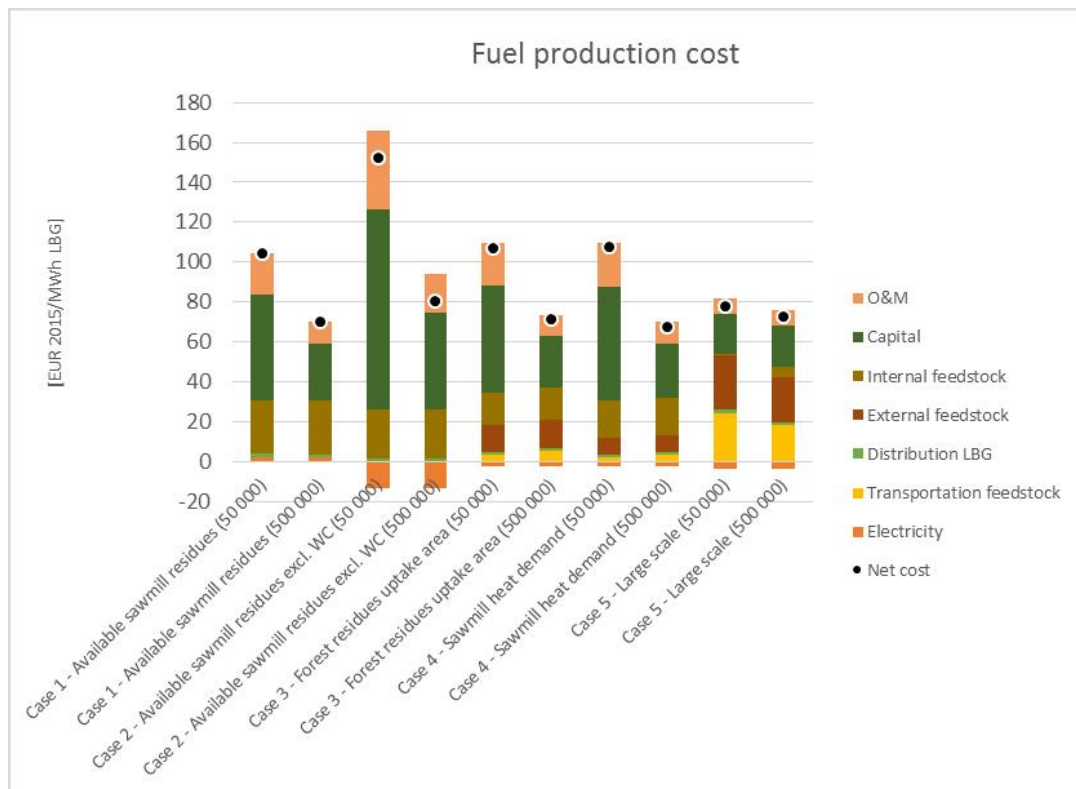

Figure 14. Fuel production cost (FPC) for all cases and the 50 000 and 500 000 m<sup>3</sup>/yr sawmill sizes.

The resulting fuel production cost spans over a range from 68 to 156 EUR/MWh<sub>LBG</sub>. In general, the plant costs (capital cost and O&M cost) have the largest impact on the economic

## Results & Discussion

performance, followed by the total feedstock cost (internal and/or external, depending on case, plus feedstock transportation). The impact of plants costs is most significant for smaller LBG plants (Case 2 – both sawmill sizes, as well as Cases 1, 4 and 3 – small sawmills), while feedstock related costs dominate for larger plants (Case 5 – both sizes, as well as Case 3 and 4 – large mills). The net electricity balance has a limited impact on the FPC.

It is apparent that in economic terms, size matters. Consequently, Case 5 (Large scale) performs best in the small size sawmill, whereas for the largest sawmill, Case 4 (Sawmill heat demand) achieves the lowest FPC and both Cases 1 and 3 perform better than Case 5. Capital cost is not a linear function, contrary to all energy related flows, but decreases non-exponentially per produced unit with increased production (economy of scale). Thus, Cases 1-4 cannot compete for the smallest sawmill size, where the total biofuel production is several orders of magnitude higher for Case 5. The high transportation cost for the feedstock clearly limits the performance of the large-scale case (Case 5), for both sizes. This is also the only case where feedstock transportation is a major contributor to the total FPC, as it constitutes about a third of the total FPC. The lowest FPCs are found for the largest sawmill cases, and for the cases with relatively efficient excess heat usage – heat load matching, i.e. Cases 4, 1 and 3, which achieve relatively similar FPCs, but with partly different cost break-downs.

Since the specific capital cost decreases with increasing size, at a certain point the increasing cost of transporting the additional required feedstock to the plant will outweigh the benefits of a larger plant. Heat integration also has a significant impact on the economic performance.

The results of the analysis show clearly that process integration is an important aspect when producing LBG integrated with a sawmill. If the biofuel process is too large in relation to the sawmill, the possibilities of extracting heat are limited, which means that the FPC becomes higher than it needs to be due to high transportation costs for feedstock.

## Chapter 6

### Conclusions

---

Three pathways towards cost efficient implementation of large scale biomass gasification units have been assessed and presented in this thesis, in order to assess the potential role of the three different aspects *feedstock*, *technology* and *value chain configuration* in decreasing the costs for gasification-based biomethane production. The results show how all evaluated pathways could contribute to increased revenues from gasification based biomethane production.

The *first pathway* (relating to the aspects of *feedstock* and *technology*) was to utilize shredded bark as feedstock for a dual fluidized bed (DFB) gasifier, and was investigated in Paper I. The experimental data presented in Paper I for industrial scale tests indicate that bark gasification is technically feasible for production of advanced biofuels. The experimental campaign has shown that it is possible to run the GoBiGas gasifier using dried bark (25-34%<sub>w.b.</sub>) and produce gas of sufficient quality for safe and stable operation of the current design of the biomethane synthesis process.

Furthermore, the results show that a similar cold gas efficiency can be achieved using different types of woody biomass (65%LHV<sub>daf</sub> for bark vs 71%LHV<sub>daf</sub> wood pellets). With a moisture content of 8%, the biomass to biomethane efficiency is about 55-65% based on the lower heating value. The feedstock related cost when producing biomethane via gasification of bark dried to about 8% is in the range of 24.2-32.7 EUR/MWh<sub>biomethane</sub> depending on the feedstock price. This is a reduction of about 42% compared to operation with commercial wood pellets. If the efficiency is pushed to 70%, which is a reasonable assumption for a commercial scale plant, the cost could be further decreased to 19-26 EUR/MWh.

The conclusion that using bark as feedstock can reach high enough efficiencies to achieve substantial economical savings compared to operation with conventional wood pellets clearly justifies continued investigation of gasification-based biofuel production concepts. The results underline that gasification technology could be applied to enable cost-efficient use of a low quality biomass feedstock; thus reducing the costs of producing biomethane.

The fact that results indicate that gasification of shredded bark can reach efficiencies similar to gasification of wood pellets also provides authenticity to the assessment in Paper III, where it was assumed that a mixture of bark, wood chips, saw dust and forest residuals could reach efficiencies similar to gasification of wood pellets. Feedstock mixtures containing a fraction of shredded bark together with wood biomass are most likely less complex than pure bark, thus it can be concluded that if bark gasification is viable, so are most biomass mixtures.

The *second pathway* (relating to the aspects of *technology* and *value chain configuration*) was to increase the biomethane production by utilizing hydrogen from water electrolysis; this was investigated in Paper II. The evaluation was performed as a scenario analysis of 4 different process configurations for utilization of hydrogen in the gasification based biomethane plant.

## Conclusions

The results show that the operating revenue increases with increased addition of hydrogen. This indicates that there is an economic incentive for integration of an electrolyser unit with the process. However, the profitability of the concept will depend on the payback demand for the additional investment. This part of the economic evaluation still remains to be completed for a more relevant assessment. The results also suggest that the input feed of H<sub>2</sub> should be maximized if this type of power-to-gas concept is implemented. From an economic perspective, the best performing configuration is to use the CO<sub>2</sub> in the raw gas, before the separation sequence; the scenario where sufficient hydrogen is added to react all CO<sub>2</sub> from the product gas reaches the higher revenue.

Even if a configuration without a CO<sub>2</sub> separation sequence outperforms the configuration including a CO<sub>2</sub> separation sequence, in terms of revenues, it is not necessarily the better alternative. The second configuration alternative is more flexible, since it allows for different flows of H<sub>2</sub>, which could be a major advantage if electricity prices fluctuate a lot. Both configurations in which CO<sub>2</sub> is separated before it is mixed with the H<sub>2</sub> display lower revenues than the first two configurations. This result highlights that it is more beneficial to mix the H<sub>2</sub> with the raw gas, rather than to separate the CO<sub>2</sub> before the reactor.

The results from evaluation of the power-to-gas pathway suggest that integration of a power-to-gas unit with a biomethane plant can contribute to lowering production costs. However, this is the least evaluated pathway presented in this thesis; as mentioned earlier it constitutes a first step in a larger evaluation. Further evaluation of the concept is needed to draw any general conclusions regarding how such a power-to-gas concept can contribute to the overall aim of this thesis, namely lowering production costs to facilitate large scale implementation of biomethane production.

The *third pathway* (relating to the aspects of *feedstock* and *value chain configuration*) was to apply process integration opportunities along the value chain of a gasification based LBG plant integrated with a generic Nordic sawmill. This assessment was presented in Paper III.

The results from the sawmill-integrated gasification-based LBG production plant shows that the size of the production plant has the largest impact on fuel production cost, followed by feedstock transportation costs for larger plants. However, the energy performance of the integrated LBG process has the largest impact on the value chain performance in terms of carbon footprint. It can be concluded that there are clear gains to be obtained by integrating gasification-based LBG production at sawmill sites, and that the gains increase with the size of the sawmill. Regarding suitable sizing criteria, a close match between excess heat from the LBG plant compared to the available heat sink of the sawmill leads to the best overall performance. This can be achieved in different ways, with similar performance identified when using all available by-products from the mill as feedstock (including the wood chips), or when supplying additional feedstock in the form of forest residues, up to a level equal to 80% of the available logging residues from the supply area of timber to the mill.

These results provide insights about which value chain parameters are most important to consider when sizing the LBG process in relation to an existing sawmill. They also visualize how the carbon footprint can be significantly decreased by integrating production gasification

## Conclusions

facilities at existing industrial sites, for a fuel type for which there is an increasing demand. Furthermore, it provides important guidelines and incentives for sawmill industries on how to make investments in renewable fuel production.

On a general level, the results from this work highlights that there are clear pathways available to increase the profitability of biomethane production with gasification technology. By adapting relatively conventional measures in terms of technology, the economic feasibility can be increased. Whether it concerns utilizing new feedstocks, making use of cheap and green electricity, or integrating the plant at an existing industrial plant site, the technology involved has often been implemented and proven in other contexts. Thus, the concepts presented in this thesis could realistically be implemented within a relatively short time frame.

Throughout this thesis, it is underlined that it is possible to utilize forest residues to produce biofuels at a cost which is reasonable. Making use of forest residuals for advanced energy purposes could thus constitute a part in a future, carbon neutral, energy system.

## Conclusions

## Chapter 7

# Outlook & Future Work

---

The licentiate is, essentially, a half-time summation of the work carried out within an ongoing PhD-project. It thereby constitutes an opportunity to validate the work performed so far, and to identify scientific issues that would be relevant and suitable for further research. Referring to the idea of system level evaluation presented in Section 1.2, it can be concluded that there is a need for deeper evaluation of two of the pathways presented in this thesis. The concepts of power-to-gas integrated with biomass gasification and gasification utilizing shredded bark as feedstock need to be evaluated from a larger system perspective to allow for more relevant conclusions.

The evaluation of using shredded bark as a feedstock in DFB gasification presented in this work focused mainly on the technical and operational aspects of switching feedstock. The assessment of economic performance and total biomass-to-fuel yield (biomethane efficiency) are both simplified and assumption based. The total plant is not modelled, and capital and operational costs related to drying the bark feedstock are not accounted for.

To quantify the large-scale possibilities of utilizing shredded bark and what impact it would have in terms of GHG emissions, the concept should be assessed from a larger systems perspective. To do this the impact on the energy balance from implementing a biomass dryer must be evaluated. Such evaluation requires modeling of the full process. Additionally, modeling of the entire biofuel plant allows for a detailed evaluation of investment and running costs, which is necessary for better quantification of economic performance. Modeling of the process also generates the total energy balance of the system, which is required to estimate process integration opportunities. As demonstrated in Paper III, process integration with existing industry is an opportunity to significantly improve the economic performance of a biorefinery.

Systematic evaluation of biorefinery concepts also simplifies comparison between different technology or feedstock pathways. Full-scale experimental testing of other feedstock alternatives, e.g. demolition wood, should be performed and the results evaluated in detail. Evaluation of different feedstock, applying the modeling framework utilized for bark in this thesis, would allow for suitable comparison. Additionally, full scale process modeling of such concepts would enable evaluation from a value chain perspective. Thus it would be possible to also quantify the impact on the feedstock value chain, the possibilities for integration with existing industries and distribution distance, similar to the evaluation performed in Paper III. Such a study could generate data needed for ex-ante assessment of the process performance within the system in which it will be implemented. Furthermore, the results could contribute to the knowledge base of different biorefinery pathways necessary not only to facilitate investment decisions by potential stake-holders, but also to allow for relevant decisions by policy-makers.

To allow for deeper evaluation of the power-to-gas concept, the optimal process configuration needs to be determined. An essential parameter for such evaluation is the impact of electricity

## Outlook & Future Work

price on the choice of process configuration and design. Part of such evaluation also requires detailed models of possible developments of the future electricity grid and at what price electricity can be assumed to be carbon neutral for each forecasted hour. The model presented in this thesis constitutes a starting point for such an evaluation. To investigate the impact of the electricity price on the process design, a rolling horizon, planning and scheduling optimization algorithm must be developed. By considering the possibility to store hydrogen, and co-running the optimization model with a model of the European electricity system, it will hopefully be possible to determine the optimal process configuration design, accounting for the fluctuations in electricity price. To enable this sort of analysis, it is a necessity to first estimate the investment costs of the different process configurations. Additionally, this gasifier concept will be compared to the possibility of using an indirect gasification concept similar to the GoBiGas plant.

In a broader sense, the pathways evaluated within this thesis will require more evaluation and research to enable broader conclusions. For any biorefinery type to make a large difference in climate change mitigation, large scale implementation will be necessary. Evaluation of large-scale implementation concepts based on utilization of new types of feedstock, such as bark or electricity, will have to account for changes in the background system in which they are to be implemented. Thus, changes in prices and what impact this might have on other aspects of the energy system needs to be considered; both in monetary and environmental terms.



## References

- 4BIOMASS PROJECT. 2018. *Biomass CHP station Senden* [Online]. Available: <https://www.4biomass.eu/en/best-practice/project-biomass-chp-station-senden> [Accessed 2018].
- ALAMIA. 2016. *Large-Scale Production and Use of Biomethane*. PhD, Chalmers university of Technology.
- ALAMIA, A., LARSSON, A., BREITHOLTZ, C. & THUNMAN, H. 2017a. Performance of large-scale biomass gasifiers in a biorefinery, a state-of-the-art reference. *International Journal of Energy Research*, 41, 2001-2019.
- ALAMIA, A., LARSSON, A., BREITHOLTZ, C. & THUNMAN, H. 2017b. Performance of large-scale biomass gasifiers in a biorefinery, a state-of-the-art reference. *International Journal of Energy Research*, DOI: 10.1002/er.3758.
- ALAMIA, A., MAGNUSSON, I., JOHNSSON, F. & THUNMAN, H. 2016a. Well-to-wheel analysis of bio-methane via gasification, in heavy duty engines within the transport sector of the European Union. *Applied Energy*, 170, 445-454.
- ALAMIA, A., ÒSK GARDARSDÓTTIR, S., LARSSON, A., NORMANN, F. & THUNMAN, H. 2017c. Efficiency Comparison of Large-Scale Standalone, Centralized, and Distributed Thermochemical Biorefineries. *Energy Technology*, 5, 1435-1448.
- ALAMIA, A., THUNMAN, H. & SEEMANN, M. 2016b. Process Simulation of Dual Fluidized Bed Gasifiers Using Experimental Data. *Energy and Fuels*, 30, 4017-4033.
- ANDERSON, J. O. & TOFFOLO, A. 2013. Improving energy efficiency of sawmill industrial sites by integration with pellet and CHP plants. *Applied Energy*, 111, 791-800.
- ANDERSSON, J., LUNDGREN, J. & MARKLUND, M. 2014. Methanol production via pressurized entrained flow biomass gasification - Techno-economic comparison of integrated vs. stand-alone production. *Biomass and Bioenergy*, 64, 256-268.
- ARVIDSSON, M., JOHANSSON, E., MORANDIN, M. & HARVEY, S. 2015a. Integration of biomass gasification-based olefins production in a steam cracker plant-global GHG emission balances. *Chemical Engineering Transactions*.
- ARVIDSSON, M., MORANDIN, M. & HARVEY, S. 2015b. Biomass gasification-based syngas production for a conventional oxo synthesis plant - Greenhouse gas emission balances and economic evaluation. *Journal of Cleaner Production*, 99, 192-205.
- ARVIDSSON, R., TILLMAN, A. M., SANDÉN, B. A., JANSSEN, M., NORDELÖF, A., KUSHNIR, D. & MOLANDER, S. 2017. Environmental Assessment of Emerging Technologies: Recommendations for Prospective LCA. *Journal of Industrial Ecology*.
- AXELSSON, E., HARVEY, S. & BERNTSSON, T. 2009. A tool for creating energy market scenarios for evaluation of investments in energy intensive industry. *Energy*, 34, 2069-2074.
- BEJO, L. 2017. Operational vs. Embodied energy: A case for wood construction. *Drvna Industrija*, 68, 163-172.
- BOLHÄR-NORDENKAMPF, M., BOSCH, K., RAUCH, R., KAISER, S., TREMMEL, H., AICHERNIG, C. & HOFBAUER, H. Scale-up of a 100kWth pilot FICFB-gasifier to a 8 MWth FICFB-gasifier demonstration plant in Güssing (Austria). Proc. 1st International Ukrainian Conference on Biomass For Energy, Kyiv, Ukraine, 2002.
- BRACK, D. 2017a. The Impacts of the Demand for Woody Biomass for Power and Heat on Climate and Forests. *London: Chatham House, the Royal Institute of International Affairs*.
- BRACK, D. 2017b. Woody Biomass for Power and Heat: Impacts on the Global Climate. *Environment, Energy and Resources Department, Chatham House, February*.

## References

- BRYNOLF, S., TALJEGARD, M., GRAHN, M. & HANSSON, J. 2018. Electrofuels for the transport sector: A review of production costs. *Renewable and Sustainable Energy Reviews*, 81, 1887-1905.
- BÖRJESSON, P., LANTZ, M., ANDERSSON, J., BJÖRNSSON, L., FREDRIKSSON MÖLLER, B., FRÖBERG, M., HANARP, P., HULTEBERG, C., IVERFELDT, E. & LUNDGREN, J. 2016. Methane as vehicle fuel - a well-to-wheel analysis *f3 The Swedish Knowledge Centre for Renewable Transportation Fuels and Foundation, Sweden. Available at [www.f3centere.se](http://www.f3centere.se).*
- BÖRJESSON, P., LUNDGREN, J., AHLGREN, S. & NYSTRÖM, I. 2013. Dagens och framtidens hållbara biodrivmedel. *f3 The Swedish Knowledge Centre for Renewable Transportation Fuels and Foundation, Sweden. Available at [www.f3centere.se](http://www.f3centere.se), 13.*
- CHRISTIANSEN, L. 2014. Skogsstatistisk årsbok 2014. *Skogsstyrelsen, Skogsstyrelsen.*
- CONNOLLY, D., MATHIESEN, B. V. & RIDJAN, I. 2014. A comparison between renewable transport fuels that can supplement or replace biofuels in a 100% renewable energy system. *Energy*, 73, 110-125.
- CONSONNI, S., KATOFISKY, R. E. & LARSON, E. D. 2009. A gasification-based biorefinery for the pulp and paper industry. *Chemical Engineering Research and Design*, 87, 1293-1317.
- CORNELISSEN, S., KOPER, M. & DENG, Y. Y. 2012. The role of bioenergy in a fully sustainable global energy system. *Biomass and Bioenergy*, 41, 21-33.
- ČUČEK, L., VARBANOV, P. S., KLEMEŠ, J. J. & KRAVANJA, Z. 2012. Total footprints-based multi-criteria optimisation of regional biomass energy supply chains. *Energy*, 44, 135-145.
- DE JONG, S., HOEFNAGELS, R., WETTERLUND, E., PETTERSSON, K., FAAIJ, A. & JUNGINGER, M. 2017. Cost optimization of biofuel production—The impact of scale, integration, transport and supply chain configurations. *Applied energy*, 195, 1055-1070.
- DELIN, L., BERGLIN, N., SAMUELSSON, Å., LUNDSTRÖM, A., BACKLUND, B. & SIVARD, Å. 2005. FRAM Final report-Application area: Model mills and system analysis. *Stockholm, Sweden: STFI-Packforsk.*
- EKBOM, T., GÅVERUD, H. & REHNLUND, B. 2012. E.ON Gasification Development AB, Marknadsförutsättningar för biodrivmedel.
- ESPING, T. 2013. Eon får miljardstöd till biogasprojekt. *Lantbruketsaffärstidning*, 2014-07-08.
- ESRI. 2018. *ArcGIS* [Online]. Available: <https://www.arcgis.com/features/index.html> [Accessed 2018-05-03 2018].
- FOUAD YUCEFI. 2018. Investerade nästan två miljarder i Gobigas – nu läggs projektet ner. *SVT nyheter*, 2018-04-03.
- FULTON, L. M., LYND, L. R., KÖRNER, A., GREENE, N. & TONACHEL, L. R. 2015. The need for biofuels as part of a low carbon energy future. *Biofuels, Bioproducts and Biorefining*, 9, 476-483.
- GASSNER, M. & MARÉCHAL, F. 2009. Thermo-economic process model for thermochemical production of Synthetic Natural Gas (SNG) from lignocellulosic biomass. *Biomass and Bioenergy*, 33, 1587-1604.
- GASSNER, M. & MARÉCHAL, F. 2012. Thermo-economic optimisation of the polygeneration of synthetic natural gas (SNG), power and heat from lignocellulosic biomass by gasification and methanation. *Energy and Environmental Science*, 5, 5768-5789.
- GRANATSTEIN, D. 2002. Case study on Lahden Lampovoima gasification project, Kymijärvi power station, Lahti, Finland. *IEA Bioenergy Agreement—Task*, 36.

## References

- GRÖBL, T., WALTER, H. & HAIDER, M. 2012. Biomass steam gasification for production of SNG - Process design and sensitivity analysis. *Applied Energy*, 97, 451-461.
- GUNDERSEN, T. 2002. What is Process Integration? *International Energy Agency: International collaboration in energy technology: a sampling of success stories*. URL: <http://www.iea.org/textbase/nppdf/free/1990/successstory99.pdf>.
- HAGBERG, M. B., PETTERSSON, K. & AHLGREN, E. O. 2016. Bioenergy futures in Sweden—Modeling integration scenarios for biofuel production. *Energy*, 109, 1026-1039.
- HANNULA, I. & KURKELA, E. 2012. A parametric modelling study for pressurised steam/O<sub>2</sub>-blown fluidised-bed gasification of wood with catalytic reforming. *Biomass and Bioenergy*, 38, 58-67.
- HANNULA, I. & KURKELA, E. 2013. *Liquid transportation fuels via large-scale fluidised-bed gasification of lignocellulosic biomass*.
- HEYNE, S. 2013. *Bio-SNG from Thermal Gasification-Process Synthesis, Integration and Performance*, Chalmers University of Technology.
- HEYNE, S., THUNMAN, H. & HARVEY, S. 2012. Extending existing combined heat and power plants for synthetic natural gas production. *International Journal of Energy Research*, 36, 670-681.
- HEYNE, S., THUNMAN, H. & HARVEY, S. 2013. Exergy-based comparison of indirect and direct biomass gasification technologies within the framework of bio-SNG production. *Biomass Conversion and Biorefinery*, 3, 337-352.
- HOKKANEN, H., AHLNÄS, T., ALAKURTTI, S., DEMIDOVA, N., FUCHS, J., IZOTOV, D., KLEEBERG, H., KOSKIMIES, S., LANGAT, M. & LYNCH, J. 2012. ForestSpeCs findings on byproducts of forest industry: could bark be more valuable than timber? *NWBC 2012*, 56.
- HOLMGREN., BERTSSON., E., A. & T., R. 2015. Comparison of integration options for gasification-based biofuel production systems - economic and greenhouse gas emission implications *Energy*.
- HOSSEINI, S. A. & SHAH, N. 2011. Multi-scale process and supply chain modelling: from lignocellulosic feedstock to process and products. *Interface focus*, rsfs20100013.
- HUBER, G. W., IBORRA, S. & CORMA, A. 2006. Synthesis of transportation fuels from biomass: Chemistry, catalysts, and engineering. *Chemical Reviews*, 106, 4044-4098.
- IEA 2013. *Technology Roadmap: Energy and GHG Reductions in the Chemical Industry via Catalytic Processes*.
- IEA 2017. *Technology roadmap delivering sustainable bioenergy*.
- ISAKSSON, J., JANSSON, M., ÅSBLAD, A. & BERTSSON, T. 2016. Transportation fuel production from gasified biomass integrated with a pulp and paper mill - Part B: Analysis of economic performance and greenhouse gas emissions. *Energy*, 103, 522-532.
- KEMP, I. C. 2011. *Pinch analysis and process integration: a user guide on process integration for the efficient use of energy*, Butterworth-Heinemann.
- KURKELA, E., KURKELA, M. & HILTUNEN, I. 2016. Steam-oxygen gasification of forest residues and bark followed by hot gas filtration and catalytic reforming of tars: Results of an extended time test. *Fuel Processing Technology*, 141, 148-158.
- KWON, P. S. & ØSTERGAARD, P. A. 2013. Priority order in using biomass resources – Energy systems analyses of future scenarios for Denmark. *Energy*, 63, 86-94.
- LNG BLUE CORRIDORS PROJECT. 2017. *LNG Blue Corridors* [Online]. Available: <http://lngbc.eu/> [Accessed 6/26 2017].
- LUND, H., HVELPLUND, F., MATHIESEN, B. V., ØSTERGAARD, P. A., CHRISTENSEN, P., CONNOLLY, D., SCHALTZ, E., PILLAY, J. R., NIELSEN, M. P. & FELBY, C.

## References

2011. Coherent energy and environmental system analysis. *Department of Development and Planning, Aalborg University*.
- MA, C., CARLBORG, M., HEDMAN, H., WENNEBRO, J., WEILAND, F., WIINIKKA, H., BACKMAN, R. & OHMAN, M. 2016. Ash formation in pilot-scale pressurized entrained-flow gasification of bark and a bark/peat mixture. *Energy & Fuels*, 30, 10543-10554.
- METROPOLIS, N. & ULAM, S. 1949. The Monte Carlo Method. *Journal of the American Statistical Association*, 44, 335-341.
- MORANDIN, M., TOFFOLO, A., LAZZARETTO, A., MARÉCHAL, F., ENSINAS, A. V. & NEBRA, S. A. 2011. Synthesis and parameter optimization of a combined sugar and ethanol production process integrated with a CHP system. *Energy*, 36, 3675-3690.
- NG, R. T. & MARAVELIAS, C. T. 2017. Design of biofuel supply chains with variable regional depot and biorefinery locations. *Renewable Energy*, 100, 90-102.
- PECK, P., GRÖNKVIST, S., HANSSON, J., LÖNNQVIST, T. & VOYTENKO, Y. 2016. Systemic Constraints and Drivers for Production of Forest-Derived Transport Biofuels in Sweden—Part A: Report. *Göteborg, Sweden: f3-The Swedish Knowledge Centre for Renewable Transportation Fuels*.
- PETTERSSON, K., WETTERLUND, E., ATHANASSIADIS, D., LUNDMARK, R., EHN, C., LUNDGREN, J. & BERGLIN, N. 2015. Integration of next-generation biofuel production in the Swedish forest industry - A geographically explicit approach. *Applied Energy*, 154, 317-332.
- SCHLERETH, D. 2015. *Kinetic and Reactor Modeling for the Methanation of Carbon Dioxide*. Dissertation, Technische Universität München, München. I.
- SOU 2013. Fossil Freedom on the road. Part 2 [Fossilfrihet på väg. Del 2. SOU 2013:84]. Stockholm,.
- SWEDISH ENVIRONMENT AND AGRICULTURE COMMITTEE 2017. Ett klimatpolitiskt ramverk för Sverige.
- SVERIGES RADIO. 2015. Ingen fortsättning för Gobigas. *Sveriges radio*, 2015-12-04.
- THE DANISH MARITIME AUTHORITY 2012. North European LNG Infrastructure Project. Available from [http://www.lngbunkering.org/sites/default/files/2012%20DMA%20North%20Europea%20LNG%20Infrastructure%20Project\\_0.pdf](http://www.lngbunkering.org/sites/default/files/2012%20DMA%20North%20Europea%20LNG%20Infrastructure%20Project_0.pdf).
- THE EUROPEAN COMMISSION 2018. 2050 low-carbon economy.
- THE SWEDISH ENERGY AGENCY. 2017. *Reduktionsplikt* [Online]. Available: <http://www.energimyndigheten.se/fornybart/hallbarhetskriterier/reduktionsplikt/> [Accessed 2018-04-23 2018].
- THE SWEDISH GOVERNMENT 2016. Sänkt skatt på biodrivmedel
- THUNMAN, H., SEEMANN, M., BERDUGO VILCHES, T., MARIC, J., PALLARES, D., STRÖM, H., KNUTSSON, P., LARSSON, A., BREITHOLTZ, C. & SANTOS, O. 2018. Advanced biofuel production via gasification – lessons learned from 200 man-years of research activity with Chalmers’ research gasifier and the GoBiGas demonstration Plant. *Energy Science and Engineering*.
- TOCK, L., GASSNER, M. & MARÉCHAL, F. 2010. Thermochemical production of liquid fuels from biomass: Thermo-economic modeling, process design and process integration analysis. *Biomass and Bioenergy*, 34, 1838-1854.
- WADSBORN, R., BERGLIN, N. & RICHARDS, T. 2007. Konvertering av mesaugnar från olje-till biobränsleledning–drifterfarenheter och modellering. *Värmeforsk, Stockholm*.
- WAGNER, H., WULF, C. & KALTSCHMITT, M. 2015. Polygeneration of SNG, heat and power based on biomass gasification and water electrolysis—concepts and their assessment. *Biomass Conversion and Biorefinery*, 5, 103-114.

## References

- WALDHEIM, L. 2015. IEA Biomass Agreement Task 33 Country Report Sweden 2015.
- WEILAND, F., WIINIKKA, H., HEDMAN, H., MARKLUND, M. & GEBART, R. 2012. Pressurized entrained flow gasification of biomass powder—initial results from pilot plant experiments. *NWBC 2012*, 136.
- WILK, V., KITZLER, H., KOPPATZ, S., PFEIFER, C. & HOFBAUER, H. 2011. Gasification of waste wood and bark in a dual fluidized bed steam gasifier. *Biomass Conversion and Biorefinery*, 1, 91-97.
- VOLVO TRUCKS. 2017. *Volvo trucks* [Online]. Available: <http://www.volvotrucks.com/en-en/trucks/volvo-fh-series/volvo-fh-lng.html> [Accessed].

# Abbreviations

A.R – As received

BFB – Bubbling Fluidized Bed

CFB – Circulating Fluidized Bed

DAG – Dry ash free

DFB – Dual Fluidized Bed (gasification)

GHG – Green House Gas

HRSC – Heat Recovery Steam Cycle

iHD - Internal Heat Demand (of gasification reactor)

LBG – Liquified Bio Gas

m.c – Moist content

SNG – Synthetic Natural Gas

w.b. – wet basis

WTT – Well to tank

WTW – Well to wheel

yr. - Year

## Acknowledgements

First of all I would like to thank my main supervisor Simon Harvey for giving me the opportunity to pursue this PhD education and for always setting time aside to support me. Without your help, this thesis would not have been possible to finish. The continuous support and encouragement from my co-supervisor Karin Petterson has meant much for me, especially during my first year when “finding myself” in the world of academia. Thank you also for your help with the first paper and for the overall discussions of my research project.

I would also like to thank Elisabeth Wetterlund for your help with the first paper, but maybe more importantly for your support throughout my entire research project. My gratitude also to Alberto Alamia for your help and patience with the bark paper, Anton Larsson and Henrik Thunman for all the support and guidance with the bark paper and regarding gasification overall, and to Stavros Papadokonstantakis for the help and cooperation in supervising the master thesis projects and supporting me in writing the second paper. I would also like to thank my Master thesis workers Andrea, Yahya and Penpaka, for the help with the power to gas assessment.

My gratitude to the Swedish Energy Agency who have financed this research project through the research school Forskarskola Energisystem. Economic support from the Swedish Research Council FORMAS is also gratefully acknowledged (dnr. 213-2014-184).

I would like to thank all my current and former colleagues at Energy Technology and IEST, especially, my roommates Sofie and Gulnara for enduring my mood switches. I would like to thank all the members of the research school, especially my friends in the best group. Jonas and Elina, thank you also for the fruitful discussions, support and for the cooperation with the paper.

I would not have gotten through this, sometimes stressful, process without great support from friends outside of work. Viktor and Lina, thank you for all the lunches and interesting discussions on other topics than work. My old hockey friends: Martin, Joel, Harry, Hallberg, Sebben, Hedlund, Henke and Niklas always helps put things in a perspective and reminds me that there is a world outside of work. Thank you for that! My greatest thanks to: Andreas, Pontus, Oscar, Olle and Johan #3 for your great friendship and all the good times outside of work which really makes it worth it all.

Without the support of my family through difficult times, this Thesis would not have been possible and for that I will be forever grateful. My greatest gratitude to: my sisters Marie and Jeanette with their families, who have always been so supportive; my brother Fredrik, the kindest person I know, your humor and relaxed way of life has sometimes caused me distress, but in the end it gives me so much joy and perspective; my mother, who has always supported me, no matter what; my late father, who has always been my greatest inspiration. I love you all.

Finally Hanna, your happiness always lifts me up, no matter what. You really are the most fantastic person and your never ending belief in me helps me through even my most desperate periods of self-doubt. I love you!