

**INTERACTIONS BETWEEN POLYUNSATURATED FATTY ACIDS  
AND PROBIOTICS**

**PASI KANKAANPÄÄ**

**FUNCTIONAL FOODS FORUM  
DEPARTMENT OF BIOCHEMISTRY AND FOOD CHEMISTRY  
UNIVERSITY OF TURKU  
TURKU 2010**

From the Department of Biochemistry and Food Chemistry  
University of Turku  
Turku, Finland

**Supervised by**

Professor Seppo Salminen  
Department of Biochemistry and Food Chemistry & Functional Foods Forum  
University of Turku  
Turku, Finland

Professor Erika Isolauri  
Department of Pediatrics  
University of Turku  
Turku, Finland

**Reviewed by**

Dr. Ross Crittenden  
CSIRO – Food and Nutritional Sciences  
Werribee, Victoria, Australia

Professor Atte von Wright  
Department of Biosciences  
University of Eastern Finland  
Kuopio, Finland

**Dissertation opponent**

Professor Christophe Lacroix  
ETH Zürich  
Institute of Nutrition and Health  
Zürich, Switzerland

**Custos**

Professor Seppo Salminen  
Department of Biochemistry and Food Chemistry & Functional Foods Forum  
University of Turku  
Turku, Finland

ISBN 978-951-29-4439-2 (paperback)  
ISBN 978-951-29-4440-8 (pdf)  
Painosalama Oy – Turku, Finland 2010

*To my Dad*

# TABLE OF CONTENTS:

<b>ABSTRACT .....</b>	<b>6</b>
<b>ABBREVIATIONS .....</b>	<b>7</b>
<b>LIST OF ORIGINAL PUBLICATIONS .....</b>	<b>8</b>
<b>1 INTRODUCTION .....</b>	<b>9</b>
<b>2 REVIEW OF THE LITERATURE .....</b>	<b>11</b>
2.1 POLYUNSATURATED FATTY ACIDS (PUFA) .....	11
2.1.1 STRUCTURE AND NOMENCLATURE .....	11
2.1.2 STORAGE AND STRUCTURAL FUNCTIONS.....	13
2.1.3 PUFA METABOLISM.....	15
2.1.4 BREAST MILK AS A PRIMARY SOURCE OF PUFA FOR INFANTS.....	17
2.1.5 PUFA AND NORMAL DEVELOPMENT OF INFANT.....	17
2.1.6 EICOSANOID BIOLOGY.....	18
2.1.7 ANTI-INFLAMMATORY NATURE OF N-3 PUFA .....	21
2.1.8 POTENTIAL CLINICAL APPLICATIONS OF N-3 PUFA.....	22
2.2 PROBIOTICS .....	24
2.2.1 THE CONCEPT OF NORMAL GUT MICROBIOTA.....	25
2.2.2 SELECTION CRITERIA OF PROBIOTICS .....	27
2.2.3 MECHANISMS OF ACTION OF PROBIOTICS IN THE GUT.....	29
2.2.4 POTENTIAL HEALTH BENEFITS OF PROBIOTICS .....	32
2.3 SUMMARY OF LITERATURE REVIEW.....	36
<b>3 AIMS OF THE PRESENT STUDY .....</b>	<b>37</b>
<b>4 SUBJECTS, STUDY DESIGNS AND ETHICS .....</b>	<b>38</b>
4.1 STUDY I .....	38
4.2 STUDY II.....	39
4.3 STUDY III.....	39
4.4 STUDY IV .....	41
<b>5 MATERIALS &amp; METHODS .....</b>	<b>42</b>
5.1 BACTERIA AND CULTURE CONDITIONS.....	42
5.2 INFANT FORMULAS .....	42
5.3 MUCUS ADHESION .....	44
5.4 CACO-2 CELL ADHESION .....	44
5.5 MICROBIAL ADHESION TO SOLVENTS.....	45
5.6 BACTERIAL VIABILITY ASSAY .....	46
5.7 PREPARATION AND ANALYSIS OF SERUM FATTY ACID SAMPLES .....	46
5.8 PREPARATION AND ANALYSIS OF PLASMA FATTY ACID SAMPLES .....	47
5.9 PREPARATION AND ANALYSIS OF BREAST MILK FATTY ACID SAMPLES.....	47
5.10 PREPARATION AND ANALYSIS OF BACTERIAL WHOLE CELL FATTY ACID SAMPLES ....	48
5.11 FOOD RECORDS.....	49
5.12 STATISTICAL ANALYSIS .....	49

<b>6</b>	<b>RESULTS</b> .....	<b>51</b>
6.1	PUFA IN MATERNAL DIET, BREAST MILK AND SERUM LIPIDS OF INFANTS (I).....	51
6.1.1	MATERNAL DIET .....	51
6.1.2	MATERNAL BREAST MILK PROFILE.....	51
6.1.3	CORRELATION BETWEEN DIET AND BREAST MILK FATTY ACIDS.....	52
6.1.4	THE INFLUENCE OF BREAST MILK ON SERUM FATTY ACID PROFILES IN INFANTS .....	52
6.2	EFFECTS OF PROBIOTICS ON PLASMA LIPID PROFILES OF INFANTS (II).....	55
6.2.1	INTER-GROUP DIFFERENCES .....	55
6.2.2	INFANTS' PLASMA LIPID PROFILE .....	55
6.2.3	EFFECT OF <i>LACTOBACILLUS</i> GG ON INFANTS' PLASMA LIPID PROFILE.....	56
6.2.4	EFFECT OF <i>BIFIDOBACTERIUM</i> Bb-12 ON INFANTS' PLASMA LIPID PROFILE ...	56
6.3	EFFECTS OF PUFA ON PHYSICOCHEMICAL PROPERTIES OF PROBIOTICS (III).....	59
6.3.1	BACTERIAL CELL FATTY ACID COMPOSITION.....	59
6.3.2	PHYSICAL PROPERTIES OF BACTERIA.....	65
6.4	THE EFFECT OF PUFA ON FUNCTIONALITY OF PROBIOTICS (IV).....	67
6.4.1	BACTERIAL GROWTH AND VIABILITY .....	67
6.4.2	BACTERIAL MUCUS ADHESION .....	69
6.5	THE EFFECT OF PUFA ON FUNCTIONALITY OF INTESTINAL EPITHELIA (IV).....	70
6.5.1	BACTERIAL CACO-2 ADHESION.....	70
<b>7</b>	<b>DISCUSSION</b> .....	<b>73</b>
7.1	PUFA AS A DIETARY FACTOR (I) .....	73
7.2	EFFECTS OF PROBIOTICS ON PLASMA LIPID PROFILES OF INFANTS (II).....	77
7.3	EFFECTS OF PUFA ON PHYSICOCHEMICAL PROPERTIES OF PROBIOTICS (III).....	79
7.4	EFFECTS OF PUFA ON FUNCTIONALITY OF PROBIOTICS (IV).....	82
<b>8</b>	<b>CONCLUSIONS</b> .....	<b>85</b>
<b>9</b>	<b>ACKNOWLEDGEMENTS</b> .....	<b>87</b>
<b>10</b>	<b>REFERENCES</b> .....	<b>89</b>
	<b>ORIGINAL PUBLICATIONS</b> .....	<b>105</b>

## ABSTRACT

The prevalence of inflammatory based diseases has increased in industrialized countries over the last decades. For allergic diseases, two primary hypotheses have been proposed to explain this phenomenon, namely the hygiene and dietary evolution based hypothesis. Particularly, the reduced early exposure to microbes and an increase in the amount of polyunsaturated fatty acids (especially n-6 PUFA) in the diet have been discussed. Often, these two factors have been studied independently, even though both factors have been shown to possess potential health benefits and their mode of action to share similar mechanisms. The hypothesis of the present study was that demonstrate that PUFA and probiotics are not separate entities as such but do interact with each other.

In the present study, we investigated whether maternal diet and atopic status influence the PUFA composition of breast milk and serum fatty acids of infants, and whether the fatty acid absorption and utilization of infant formula fatty acids is affected by supplementation of infant formula with probiotic bacteria (*Lactobacillus* GG and *Bifidobacterium lactis* Bb-12). Moreover, we investigated the mechanisms by which different PUFA influence the physicochemical and functional properties of probiotics as well as functionality of epithelial cells *in vitro*.

We demonstrated a carry-over effect of dietary fatty acids from maternal diet via breast milk into infants' serum lipid fatty acids. Our data confirmed the previously shown allergy -related PUFA level imbalances, though it did not fully support the impaired desaturation and elongation capacity hypothesis. We also showed that PUFA incorporation into phospholipids of infants was influenced by probiotics in infant formula in a strain dependent manner. Especially, *Bifidobacterium lactis* Bb-12 in infant formula promoted the utilization of n-3 PUFA.

Mechanistically, we demonstrated that probiotics (*Lactobacillus* GG, *Lactobacillus casei* Shirota and *Lactobacillus bulgaricus*) did incorporate and interconvert exogenous free PUFA in the growth medium into bacterial fatty acids strain and PUFA dependently. In general, high concentrations of free PUFA inhibited the growth and mucus adhesion of probiotics, whereas low concentrations of specific long chain PUFA were found to promote the growth and mucus adhesion of *Lactobacillus casei* Shirota. These effects were paralleled with only minor alterations in hydrophobicity and electron donor – electron acceptor properties of lactobacilli. Furthermore, free PUFA were also demonstrated to alter the adhesion capacity of the intestinal epithelial cells; n-6 PUFA tended to inhibit the Caco-2 adhesion of probiotics, whereas n-3 PUFA had either no or minor effects or even promote the bacterial adhesion (especially *Lactobacillus casei* Shirota) to PUFA treated Caco-2 cells.

The results of this study demonstrate the close and bilateral interactions between dietary PUFA and probiotics. Probiotics were shown to influence the absorption and utilization of dietary PUFA, whereas PUFA were shown to alter the functional properties of both probiotics and mucosal epithelia. These findings suggest that a more thorough understanding of interactions between PUFA and intestinal microbiota is a prerequisite, when the beneficial effects of new functional foods containing probiotics are designed and planned for human intervention studies.

## ABBREVIATIONS

Abbreviation	Description
5-LO	5-lipoxygenase
AAD	antibiotic associated diarrhea
ATCC	American Type Culture Collection
CE	cholesterol ester
CFU	colony forming unity
CLA	conjugated linoleic acid
COX	cyclooxygenase
EFA	essential fatty acids
GPCR	G protein coupled receptor
HETE	hydroxyeicosatetraenoic acid
HPETE	hydroperoxyeicosatetraenoic acid
IBD	inflammatory bowel disease
IBS	irritable bowel syndrome
IFN	interferon
Ig	immunoglobulin
IL	interleukin
LT	leukotriene
MATS	microbial adhesion to solvents
MEM	Minimal Essential Medium
MRS	DeMan, Rogosa, Sharpe medium
MUFA	monounsaturated fatty acid
NK	Natural Killer cells
PG	prostaglandin
PL	phospholipids
PLA <sub>2</sub>	phospholipase A <sub>2</sub>
PPAR	peroxisome proliferator activated receptor
PUFA	polyunsaturated fatty acid
SD	standard deviation
SEM	standard error of mean
SFA	saturated fatty acid
TG	triglycerides
TGF	transforming growth factor
Th1 and Th2	T helper cell type 1 & 2
TNF	tumor necrosis factor
Tx	thromboxane

## LIST OF ORIGINAL PUBLICATIONS

This thesis is based on the following publications, referred to in the text by their Roman numerals:

- I Kankaanpää, P, Nurmela, K, Erkkilä A, Kalliomäki M, Holmberg-Marttila D, Salminen S and Isolauri E (2001). Polyunsaturated fatty acids in maternal diet, breast milk, and serum lipid fatty acids of infants in relation to atopy. *Allergy* **56**:633-638
- II Kankaanpää PE, Yang B, Kallio HP, Isolauri E and Salminen SJ (2002). Influence of probiotic supplemented infant formula on composition of plasma lipids in atopic infants. *J Nutr Biochem* **13**:364-369
- III Kankaanpää P, Yang B, Kallio H, Isolauri E and Salminen S (2004). Effects of polyunsaturated fatty acids in growth medium on lipid composition and on physicochemical surface properties of lactobacilli. *Appl Environ Microbiol* **70**(1):129-136
- IV Kankaanpää PE, Salminen SJ, Isolauri E and Lee YK (2001). The influence of polyunsaturated fatty acids on probiotic growth and adhesion. *FEMS Microbiol Lett* **194**:149-153



# 1 INTRODUCTION

The prevalence of atopic diseases has increased in industrialized countries over the last two decades (Isolauri and Salminen 2008). Two primary hypotheses have evolved to explain this phenomenon, namely hygiene and dietary evolution based hypothesis.

In the late 1980, Strachan proposed the hygiene hypothesis linking the modern hygiene conditions common in Western societies to increased prevalence of atopic conditions (Strachan DP 1989). According to this hypothesis, early infections may prepare the immature immunity of infants to cope with allergens and therefore reduce the prevalence of allergy by skewing the T helper cell type 2 responses (Th2) towards the T helper cell type 1 (Th1) responses (Isolauri and Salminen 2008). In this context, the development of intestinal microbiota has been suggested to be crucial in the maturation of immunity in infants (Ouweland et al. 2002). Consequently, the so-called probiotic therapy in the prevention and treatment of allergic disorders in infants was suggested (Salminen et al. 1996). Though the evidence that probiotics may prevent the development of atopy and reduce allergic symptoms in existing atopic disease is accumulating for specific probiotic strains, the recent meta-analyses indicate that the hygiene hypothesis warrants further investigations (Boyle et al 2009, van der Aa et al. 2009).

Approximately 10 years later, an alternative hypothesis based on dietary evolution was proposed (Black and Sharpe 1997) which relied on the epidemiological finding showing that increase in prevalence of atopic diseases is paralleled by a fall in the consumption of saturated fat and an increase in the amount of polyunsaturated fatty acids (PUFA) in the diet. More recent epidemiological studies indicate that human beings evolved on a diet with a ratio of n-6 to n-3 PUFA of approximately 1, whereas in modern Western diets this ratio is now approaching 17 (Simopoulos 2006). This increase has mainly been attributed to increase in the use of margarine and vegetable oils rich in n-6 PUFA, whereas the consumption of n-3 PUFA has gradually decreased (Winkler et al. 1992, Nakagomi et al. 1994). The mechanistic rationale of such hypothesis is that linoleic acid as a precursor of arachidonic acid (20:4 n-6) leads to higher levels of prostaglandins (e.g. PGE<sub>2</sub>) which inhibit interferon-gamma production and favor a switch to immunoglobulin E (IgE) production propagating the Th2 skewed immune system (Calder PC 1998, Kankaanpää et al. 1999) that has been shown to be a characteristic of allergic inflammation (Romagnani 2000). On the contrary, n-3 fatty acids

and eicosanoids derived from them have been demonstrated to possess anti-inflammatory properties (Calder 2006).

Mother's diet influences the fatty acid composition of breast milk, which in turn acts as the primary source of energy and nutrients for infants within the first months of neonatal life (Mellies et al. 1979). Although breastfeeding is strongly recommended for its multiple benefits on child health, most recent studies do not confirm the '*conventional wisdom*' of breastfeeding being protective against allergy and asthma (Duncan and Sears 2008). Since human breast milk PUFAs are efficiently transferred to infant serum fatty acids (Kohn et al. 1994), the variations in breast milk PUFA proportions may explain why breastfeeding has diverse influence on the prevention of atopic diseases (Isolauri et al. 1999, Sears et al. 2002, van Odijk et al. 2003). In relation to this, there are several reports showing that both breast milk fatty acid profiles and serum fatty acid profiles may be abnormal in relation to allergy (Yu et al. 1998a&b, Businco et al. 1993, Manku et al. 1984). Subsequently, PUFA, especially n-3 PUFA, have been suggested to be of benefit in conditions with inflammatory element, e.g. allergies (Calder 2006).

Thus far, PUFA and probiotics in the management of allergy have been considered separately. Both factors have been shown to possess potential benefits and their mode of action share similar mechanisms. The hypothesis of the present study was that these two factors, PUFA and probiotics are not separate entities *per se* but do interact with each other.

## 2 REVIEW OF THE LITERATURE

### 2.1 POLYUNSATURATED FATTY ACIDS (PUFA)

Nearly 98% of dietary lipids are in the form of triacylglycerols in which usually at least two, often three, fatty acid molecules are esterified to a molecule of glycerol. The rest of the dietary lipids include phospholipids, free fatty acids, monoglycerides, diglycerides and sterols (Mu and Høy 2004).

Dietary lipids are digested gradually within the alimentary tract. Digestion begins within the acidic environment of stomach where lingual and gastric lipases hydrolyse short to medium chain fatty acids (max 10 carbons) and long chain fatty acids (>10 carbons) from triacylglycerols, respectively (Hamosh 1979). At this point, some of the released fatty acids (mainly short- and medium-chain fatty acids) may be absorbed, but the majority of the released fatty acids as well as non-hydrolyzed lipids enter the duodenum where monoacylglycerols and free fatty acids stimulate the contraction of the gall bladder and secretion of pancreatic enzymes, such as pancreatic lipase and colipase (Borgström and Donner 1977). These enzymes continue the hydrolysis of triacylglycerols, the action of which is potentiated by bile acids secreted from gall bladder. Within the ileum, bile acids also solubilize the released free long-chain fatty acids by forming micelles that are then transferred into enterocyte. Eventually, the absorbed long-chain fatty acids enter peripheral circulation in the form of chylomicrons (Mu and Høy 2004).

#### 2.1.1 Structure and nomenclature

Naturally occurring fatty acids are straight-chain carboxylic acids that contain an even number of carbon atoms (generally 4-24). Short-chain fatty acids contain  $\leq 4$  carbon atoms, medium-chain fatty acids 6-10 carbon and long-chain fatty acids  $10 \geq$ . Long chain fatty acids having 20 or more carbons are sometimes called very long-chain fatty acids. The carboxylic chain may be saturated (SFA; i.e. no double bonds in the carbon chain), monounsaturated (MUFA; i.e. containing one double bond) or polyunsaturated (PUFA; i.e. containing two or more double bonds). As an example, the structures of stearic, oleic, linoleic and  $\alpha$ -linolenic acids are shown in Figure 1.

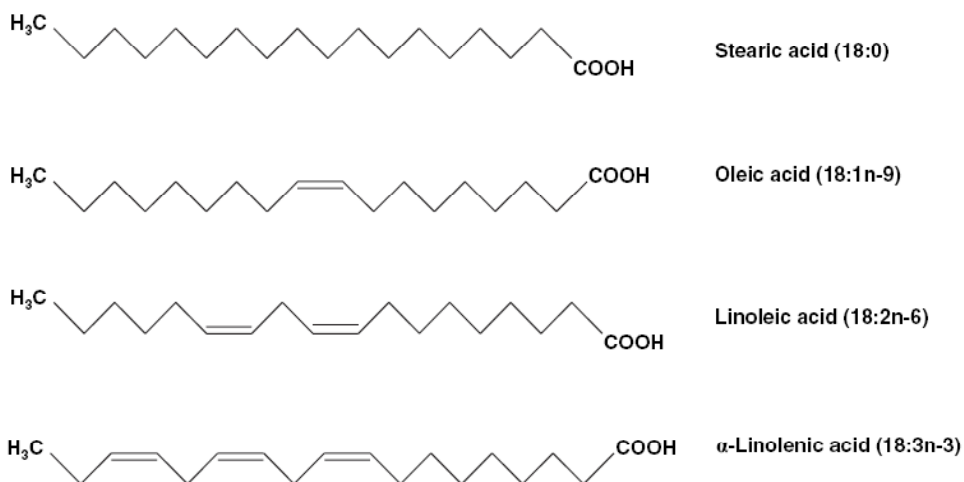

**FIGURE 1.** The structures of stearic, oleic, linoleic and  $\alpha$ -linolenic acid.

Even though, many fatty acids have trivial names, a systematic nomenclature identifies fatty acids by the number of carbon atoms, the number of double bonds and the site of the first double bond from the terminal methyl group of the molecule. The carbon atoms are numbered starting from the carboxyl carbon, and the carbon at the methyl end of the carboxylic chain is called the  $n^{\text{th}}$  carbon or the  $\omega$ -carbon. For example,  $\alpha$ -linolenic acid (Figure 1) is a trivial name for 9,12,15-octadecatrienoic acid (systematic name) and is designated 18:3n-3 or 18:3 $\omega$ 3, indicating that it is an 18 carbon fatty acid with 3 carbon-to-carbon double bonds, the first from the methyl terminal between the 3<sup>rd</sup> and 4<sup>th</sup> carbon. The trivial names, numerical designations and the systematic names of some common fatty acids are shown in Table 1.

Naturally occurring PUFA are divided into two major families according to the location of the first double bond (from the methyl end), namely n-3 and n-6 series (also n-9 series exists). Because humans do not have enzymes capable of introducing double bonds beyond the 9th carbon from the carboxyl terminal, the n-3 and n-6 PUFA have to be obtained from the diet (Calder 2006). Therefore, the parent n-6 and n-3 PUFA, namely linoleic acid and  $\alpha$ -linolenic acid, respectively, are also called essential fatty acids (EFA) must be obtained from the diet. EFA are used as parts of cell membranes and in the synthesis of hormone-like substances.

**TABLE 1.** Fatty acid nomenclature; some common fatty acids.

Trivial name (common abbreviation)	Numerical designation	Systematic name
Saturated fatty acids		
Lauric acid	12:0	Dodecanoic acid
Myristic acid	14:0	Tetradecanoic acid
Palmitic acid	16:0	Hexadecanoic acid
Stearic acid	18:0	Octadecanoic acid
Monounsaturated fatty acids		
Palmitoleic acid	16:1n-7	9-hexadecenoic acid
Vaccenic acid	18:1n-7	11-octadecenoic acid
Oleic acid	18:1n-9	9-octadecenoic acid
Polyunsaturated fatty acids		
$\alpha$ -linolenic acid (ALA)	18:3n-3	9,12,15-octadecatrienoic acid
Timnodonic acid (EPA)	20:5n-3	5,8,11,14,17-eicosapentaenoic acid
Clupadonic acid	22:5n-3	7,10,13,16,19-docosapentaenoic acid
Cervonic acid (DHA)	22:6n-3	4,7,10,13,16,19-docosaheptaenoic acid
Linoleic acid (LA)	18:2n-6	9,12-octadecadienoic acid
$\gamma$ -linolenic acid (GLA)	18:3n-6	6,9,12-octadecatrienoic acid
Dihomo- $\gamma$ -linolenic acid (DHGLA)	20:3n-6	8,11,14-eicosatrienoic acid
Arachidonic acid (AA)	20:4n-6	5,8,11,14-eicosatetraenoic acid
Adrenic acid	22:4n-6	7,10,13,16-docosatetraenoic acid
Osbond acid	22:5n-6	4,7,10,13,16-docosapentaenoic acid
Mead acid	20:3n-9	5,8,11-eicosatrienoic acid

### 2.1.2 Storage and structural functions

Fats (triacylglycerols) are the most important long-term energy reservoirs in the body of animals because they represent a highly efficient form of energy storage. Due to their chemical structure (they are “less oxidized” than other dietary molecules), they generate significantly more energy than carbohydrates or proteins when they are broken down. Because fats do not mix with water, they, unlike carbohydrates, are stored without attached water molecules. In fact, fats possess over two-fold caloric value per unit mass compared to carbohydrates and proteins.

The body stores triglycerides in adipocytes that can be almost entirely filled with fat globules. Adipocytes take up triacylglycerols that are synthesized in the liver and transported by blood. In addition, the adipocytes can synthesize triacylglycerols themselves from fatty acids and glycerol-3-phosphate especially when the level of nutrients in the body is high. On the other hand, when the body needs nutrients, the energy reserves are mobilized by breaking down triacylglycerols to fatty acids and glycerol by lipases. The fatty acids and glycerol are released

from the adipocytes into blood and transported to the liver where they can be converted directly into energy. Alternatively, glycerol can be converted to glucose and fatty acids to ketone bodies that can be utilized for energy generation by other organs and tissues (Mu and Porsgaard 2005).

The hormones such as epinephrine, norepinephrine, glucagon, and adrenocorticotrophic hormone increase the number and activity of lipases and therefore stimulate the energy generation from triglycerides. Insulin, on the other hand, suppresses lipases and slows down the utilization of the body's energy reservoir in the adipocytes (Wanten and Calder 2007, Mu and Høy 2004, Ahmadian et al 2009).

Within and around all living cells are membranes. They serve as physiological boundaries to the cell itself as well as to the various cell compartments. In 1972, Singer and Nicholson proposed that biological membranes compose of lipid bilayer having a number of different proteins distributed throughout them (Singer and Nicholson 1972). For the first time, the fluid mosaic model of biological membranes was proposed. It is now understood that changes in lipid components of the membrane can affect the function of the membrane itself, and hence the function of the cell.

Phospholipids are regarded as principle lipids in the membranes (~90%). The amphipathic nature of the phospholipids is also the reason the membrane exists as a lipid bilayer. The polar region (the phosphorylated substitute (e.g. ethanolamine, inositol or choline) at carbon 3 of the triacylglycerol backbone) is hydrophilic and is positioned such that it is in contact with the aqueous media, whereas the nonpolar (i.e. fatty acid region) is oriented toward the center of the bilayer. Membranes whose phospholipid fatty acids are saturated are more rigid than those membranes containing unsaturated fatty acids. The other major classes of lipids in membranes include glycolipids and cholesterol. These have a role in the cell surface-associated antigens and in the regulation of membrane fluidity, respectively (Lodish et al. 2000).

Physical properties of the membranes are pivotally affected by their lipid composition that in turn is influenced by environmental factors such as diet. The most prevalent PUFA components of phospholipids are linoleic acid (n-6; especially rich in cardiolipids) and arachidonic acid (n-6) and docosahexaenoic acid of the n-3 family (especially rich in the brain). Changes in the membrane properties may indeed modulate the activities of enzymes or

receptors (for substances such as hormones and antigens) located within the membrane. For example, specific deficits of n-3 PUFA in the membranes of central nervous system may influence neural integrity and selectively affect learning and visual abilities (Bourre et al. 1988 and 1989, Birch et al. 1998). The effect of PUFA on visual functions as well as on cognitive and behavioral development will be discussed in more detail in chapter 2.1.5.

### 2.1.3 PUFA metabolism

The cells of most tissues are capable of synthesizing fatty acids at low rates, though the majority of *de novo* synthesis of fatty acids occurs in liver and adipose tissue. Nevertheless, other tissues such as lactating mammary gland may also synthesize large amounts of PUFA for the needs of the newborn. Overall, the metabolic pathways of PUFA are under control of many dietary and hormonal factors. The metabolism of fatty acids is a multistep process containing a number of enzymes. The basic principle in both synthesis and degradation pathways are the addition or deletion of two-carbon molecules in each round of process (Wanten and Calder 2007).

Long-chain PUFAs are synthesized by an alternating sequence of desaturation and elongation from the parent PUFA (Figure 2). Both parent PUFA families utilize the same enzymes. In the first process (i.e. desaturation), two hydrogens are removed by membrane-bound enzymes called desaturases that are specifically named according to the fixed position of the newly formed double bond from the carboxyl terminal, e.g.  $\Delta 6$  desaturase adds a double bond between the 6<sup>th</sup> and 7<sup>th</sup> carbons (from the carboxyl terminal) irrespective of the chain-length of the fatty acid. Altogether, humans (as well as higher mammals) have four desaturases:  $\Delta 4$ ,  $\Delta 5$ ,  $\Delta 6$  and  $\Delta 9$ . In the elongation, two additional carbons are added to the hydrocarbon backbone by the so-called endoplasmic reticulum pathway (Sprecher et al. 1995, Nakamura et al 2001).

There are several factors affecting the efficacy of PUFA synthesis, especially the desaturation steps. The rate-limiting step of the whole chain of desaturation and elongation of parent PUFA is the first desaturation reaction catalyzed by  $\Delta 6$ -desaturase (Nakamura et al. 2001, Brenner 1977). It has been shown that parent n-6 PUFA as well as their longer chain PUFA derivatives does possess feedback regulatory influence on  $\Delta 6$ -desaturase activity (Cho et al. 1999). Also,  $\Delta 6$ -desaturase has different affinity for the different substrates, i.e. parent PUFA; the affinity increases with the increasing number of pre-existing double bonds ( $18:3n-3 >$

18:2n-6 > 18:1n-9) and is dependant on chain length (18 carbon unsaturated FA > 29 carbon unsaturated FA)(Castuma et al. 1977). Excessive supplementation of either n-3 or n-6 PUFA in the diet may therefore cause a deficiency in the other group by shutting down the synthetic pathway shared by n-3 and n-6 PUFA (Nakamura et al. 2001). Moreover, tracer studies have shown that only a small proportion of dietary parent PUFA are converted to their longer chain derivatives implying that PUFA synthesis from these precursors may be insufficient (Brenna et al. 2009). The uptake of longer chain PUFA from the diet (compared to their *de novo* synthesis from parent PUFA) have also been shown to be more effective, especially early in life (Hornstra 2000). Thus, dietary supplementation of longer chain PUFA (e.g. in infant formulas) may therefore be necessary for the early stages of development (Koletzko et al. 2008).

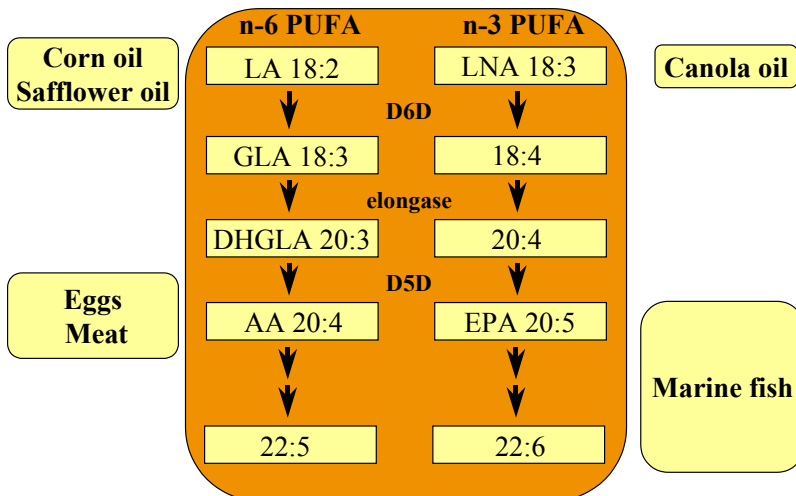

**FIGURE 2.** Long-chain PUFA are synthesized by an alternating sequence of desaturation and elongation from the parent PUFA. Some major dietary sources of PUFA are also shown in the schematic illustration below (Nakamura et al 2001).

There are two known degradation pathways of PUFA. Longer chain PUFA could be either metabolized (unidirectional reaction) to eicosanoids that are further metabolized to their inactive forms and excreted in urine (Lands 1991) or PUFA could be  $\beta$ -oxidized in mitochondria and peroxisomes (Hiltunen et al. 1996), the latter being the primary site of oxidation of excess PUFA (Nakamura et al. 2001). In fact, both n-3 and n-6 longer chain



PUFA induces its own oxidation via a feed-forward mechanism, which is mediated by peroxisome proliferator activated receptor- $\alpha$  (PPAR- $\alpha$ ) (Forman et al. 1997).

#### **2.1.4 Breast milk as a primary source of PUFA for infants**

Breast milk contains a number of components of nutritional significance. With the average fat content of about 4% (in mature milk), breast milk serves as a sole source of essential PUFA to the breast -fed infant (Sauerwald et. 2001). Linoleic acid is abundant, and the proportional content of this n-6 essential PUFA has increased two-fold within last decades (Jensen 1999), reflecting the n-6 PUFA predominant Western diet. This imbalance has resulted in elevated linoleic acid to  $\alpha$ -linolenic acid ratio seen in different studies investigating lipid composition of human milk (Koletzko et al 1992, Sauerwald et al. 2001). In addition to essential fatty acids, long chain PUFA, especially arachidonic acid and other n-6 long chain PUFAs are prevalent in breast milk, even though these fatty acids can be generated endogenously even by very premature infants (Sauerwald et al 1997). In general, the PUFA profiles of breast milk can be considered to be rather stable, though under special dietary conditions, levels of e.g. docosahexaenoic acid may vary 20-fold (Putnam et al 1982, Ruan et al. 1995, Li et al. 2009).

Breast milk composition, in terms of fatty acids, is influenced by maternal diet. For example, mothers following vegetarian diet do possess high linoleic and  $\alpha$ -linolenic acid content in their breast milk (Hopppu et al 2005, Sanders and Reddy 1992, Finley et al. 1985). On the other hand, diets rich in marine foods propagate higher long chain n-3 PUFA levels in human milk (Ruan et al. 1995, Li et al. 2009). Rapid transporting of the dietary fatty acids into breast milk seems constitutes only a fraction of the PUFA in breast milk (Francois et al. 1998) whereas the preponderance is derived from intermediate storage pools of these fatty acids (Demmelmair et al 2001).

#### **2.1.5 PUFA and normal development of infant**

Since human milk fat is the major source of energy for the newborn (~40-55% of total energy intake), the quality of dietary lipid composition during early phases of the infant life has a pivotal impact on body composition, tissue differentiation and other organ functions (Koletzko and Rodriguez-Palmero 1999, Koletzko et al 2001).

Early in human growth PUFA are considered as essential components in the membrane lipid layers of all tissues. PUFA can modulate the membranes by affecting their fluidity, permeability, enzymatic activity and signal transduction pathways (Koletzko and Rodriguez-Palmero 1999, Clandinin et al 1994). In particular, synaptosomal membranes and retinal photoreceptors are rich in PUFA, the deposition of which (via placenta) is started already during the fetal period (Koletzko 1992b), and continues after birth (from breast milk) for approximately one year (Makrides et al. 1994). In the same manner, consumption of infant formula fortified with PUFA has been shown to result in higher docosahexaenoic and arachidonic acid status (Gibson RA et al. 2009). Especially, the importance of docosahexaenoic acid and arachidonic acid for the normal visual and mental development has been emphasized (Koletzko et al. 2008). Still, prior to 2002 in the US, formula-fed infants did not receive these fatty acids and relied solely on endogenous conversion of the dietary essential n-3 and n-6 fatty acids (Hoffman et al. 2009). Now it is generally accepted that infants should receive at least 0.3% of both docosahexaenoic acid and arachidonic acid in infant feedings (Koletzko et al 2008), even though higher docosahexaenoic acid levels in formulas have been suggested to special group such as preterm infants (Makrides et al. 2009). Moreover, there's some new clinical evidence suggesting that an arachidonic acid to docosahexaenoic acid ratio greater than 1 is associated with improved cognitive outcomes (Hoffman et al. 2009, Agostoni 2008).

In addition to brain and eye development, PUFA supplementation has been linked to gain in weight and body length especially among the preterm infants (Lapillione and Carlson 2001, Carlson et al. 1992, Makrides et al. 2009). As an example, the effect of maternal fish oil supplementation during lactation on growth parameters of infants / children have been shown to be persistent up to 2.5 years of their life (Lauritzen et al 2005). There is also increasing evidence that dietary counseling starting from 1<sup>st</sup> trimester of pregnancy does influence the placental phospholipid fatty acid profiles thus potentially altering the fetal environment (Kaplan et al. 2007). Similarly, dietary counseling has been shown to diminish the risk of larger birth size – a significant risk marker for later obesity (Luoto et al. 2010).

### **2.1.6 Eicosanoid biology**

Eicosanoids are a diverse group of chemical messengers such as prostaglandins (PG), leukotrienes (LT), thromboxanes (Tx), lipoxins, hydroperoxyeicosatetraenoic acids (HPETE)

and hydroxyeicosatetraenoic acids (HETE) that are implicated in functions in practically every organ, tissue and cell in our body (Nakamura et al. 2001, Calder 2001 & 2006, Wanten and Calder 2007). These compounds provide a link between PUFA and immune functions. In addition, they work as autocrine / paracrine hormones (i.e. they signal at or immediately adjacent to their site of synthesis – eicosanoids are not stored) to mediate a variety of other functions such as pain, fever, blood pressure regulation and blood coagulation (Nakamura et al 2001). In summary, one of the most important function of parent PUFA, linoleic and linolenic acids, is as a precursor of longer-chain PUFA and their eicosanoid derivatives. For simplification, only the biosynthesis and functions of arachidonic acid derived prostaglandins (PG) and leukotrienes (LT) are discussed and presented (Figure 3) below.

Because the membranes of immune cell contain much more arachidonic acid than dihomo- $\gamma$ -linolenic acid and eicosapentaenoic acid in their phospholipids, arachidonic acid is usually the principal eicosanoid precursor in mammalian cells (Calder 2001). As yet, the composition of the eicosanoid family has expanded immensely in the past two decades to include virtually all oxygenated PUFA products, whether formed enzymatically or non-enzymatically (Funk 2001). *De novo* synthesis of PG starts with the release of arachidonic acid from the cell membrane phospholipids, usually by action of phospholipase A<sub>2</sub> (PLA<sub>2</sub>) activated in response to mechanical trauma or other stimuli such as cytokine and growth factor stimuli (Zhou and Nilsson 2001). At the endoplasmic reticulum and nuclear membrane, free arachidonic acid is presented to prostaglandin synthetase, i.e. cyclooxygenase (COX), and is then metabolized to an intermediate PGH<sub>2</sub>. There are two isoforms of COX enzymes, namely COX-1 and COX-2, the first of which is responsible for basal, continuous PG synthesis whereas the latter is important in inflammation and other induced settings (Smith et al. 2000). Further downstream metabolism of PGH<sub>2</sub> is orchestrated in a cell-specific manner; thromboxanes (Tx) are synthesized in platelets and macrophages, PGF synthase is found in utero whereas PGE<sub>2</sub>, mediator found in inflammatory settings, is synthesized in most cells by microsomal PGE synthase (Funk 2001, Jacobsson et al. 1999, Mancini et al. 2001). In contrast to PGs synthesized by variety of cell types, inflammatory cells such as polymorphonuclear leukocytes, macrophages and mast cells make the vast majority of LTs. The key enzymes in the synthesis of LTs are PLA<sub>2</sub> and 5-lipoxygenase (5-LO) that elicit a sequence of events following the cellular activation mediated by immune complexes, bacterial peptides or other stimuli. 5-LO transforms released PUFA, in most cases arachidonic acid, to the hydroxy (HETE) and hydroxyperoxy derivatives (HPETE) as well as to the 4-series LTs; A<sub>4</sub>, B<sub>4</sub>, C<sub>4</sub>,

D<sub>4</sub> and E<sub>4</sub> (Funk 2001). LTA<sub>4</sub> can be considered as primary state since the other bioactive eicosanoids of 4-series are transformed from that (Gronert et al 1999). These transformation reactions depend on the cellular context and include hydrolysis (LTB<sub>4</sub>; e.g. neutrophils), conjugation with glutathione (LTC<sub>4</sub>) and further extracellular metabolism (the glutathione moiety of LTC<sub>4</sub> is metabolized to form LTD<sub>4</sub> and LTE<sub>4</sub>) (Samuelsson 1983, Peters-Golden and Brock 2001).

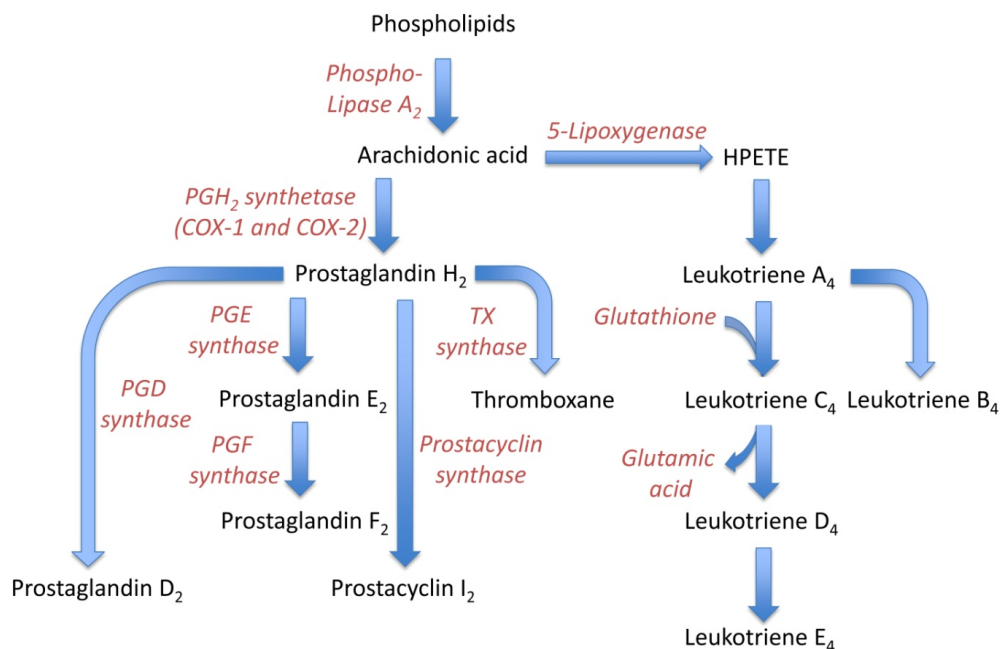

**FIGURE 3.** Schematic illustration of biosynthetic pathways of arachidonic acid derived prostaglandins (PG), leukotrienes (LT) and thromboxane (TX).

PGs and LTs modulate their physiological effects via G protein coupled receptors (GPCR) located at the plasma membrane of effector cells. These eicosanoid receptors are classified in four main groups: the BLT receptors, with biological activities related to LTB<sub>4</sub>, the cysteinyl LTs receptors related family, the lipoxin receptors and the prostanoid receptors class (Brink et al. 2003). As yet, there are indications that eicosanoids do not solely exert their actions through GPCRs but peroxisome proliferator activated receptors (PPAR) might also be activated by a variety of eicosanoids (Gupta et al. 2000, Wang and DuBois, 2008).

PGE<sub>2</sub> has been considered as proinflammatory mediator mediating actions such as induction of fever and erythema, increasing vascular permeability and vasodilatation and enhancing, say histamine derived pain and edema (Calder 2006). It can also be regarded as immunosuppressive agent since it has been shown to suppress lymphocyte proliferation and natural killer (NK) cell activity as well as to inhibit synthesis of anti-inflammatory cytokines such as tumor necrosis factor (TNF)- $\alpha$ , interleukin (IL)-1, IL-6, IL-2 and interferon (IFN)- $\gamma$  without any influence on Th2 cytokines IL4 and IL-10 (Calder 2001). However, PGE<sub>2</sub> does potentiate IgE production thus promoting a persistent allergic inflammation (Black and Sharpe 1997, Chan et al 1993). Like PGE<sub>2</sub>, LTB<sub>4</sub> possess a series of proinflammatory properties (induced vascular permeability, enhances blood flow, attract leukocytes to the site of inflammation, inhibit lymphocyte proliferation), but unlike PGE<sub>2</sub>, LTB<sub>4</sub> promotes NK cell activity and induces the synthesis of TNF- $\alpha$ , IL-1, IL6, IL-2 and IFN- $\gamma$  (Calder 2001). The overall physiological effect of a given mediator is strongly dependent on concentration of the eicosanoid, location and timing of its production as well as the sensitivities of target cells to their effects. Among others, cofactors such as genetic predisposition, general health status and type of stimulation have been suggested as contributors of the responsiveness to PUFA in terms of immune functions (Wu 2004).

### **2.1.7 Anti-inflammatory nature of n-3 PUFA**

Even though the majority of anti-inflammatory potential of n-3 PUFAs is based on their action in antagonizing arachidonic acid metabolism, several studies have demonstrated that these fatty acids do possess eicosanoid independent anti-inflammatory mechanisms as well (Calder 2006). Dietary supplementation of n-3 PUFA (eicosapentaenoic and docosahexaenoic acid) have been shown to inhibit chemotaxis of human neutrophils and monocytes time- and dose-dependently (Healy et al. 2000, Schmidt et al. 1989) as well as decrease the expression of certain adhesion molecules on the surface of leukocytes (Thies et al. 2001, De Caterina and Libby 1996). In addition, dietary supplementation of n-3 PUFA has been shown to directly decrease the production of reactive oxygen species (by 30-55%) and inflammatory cytokines (especially TNF- $\alpha$ , IL-1 and IL-6) in several studies though discrepant results have been reported (Calder 2006).

### **2.1.8 Potential clinical applications of n-3 PUFA**

Many human diseases and conditions contain the element of inflammation, characterized by the excessive production of inflammatory mediators such as eicosanoids (Calder 2006). N-3 and n-6 PUFA are precursors for eicosanoids and other lipid mediators that are powerful regulators of many biological functions such as trombocyte aggregation, anti-infective and anti-inflammatory processes (Endres 1993). In addition, the n-3 and n-6 PUFA can also directly influence the regulation of gene expression, and cell signaling (Innis et al 2006). As a general statement, n-6 derived eicosanoids (especially the ones derived from arachidonic acid) are more potent proinflammatory mediators, whereas n-3 derived eicosanoids (i.e. the ones derived from primary eicosapentaenoic acid and docosahexaenoic acid) are regarded as more anti-inflammatory in nature (Calder 2006, Simopoulos 2008). Since the delicate balance between n-6 and n-3 PUFA mediate and regulate these responses, the role of PUFA in determining the development and magnitude of inflammation have been suggested (Simopoulos 2008, Calder 2006, Kankaanpää et al. 1999, Black and Sharpe 1997). This activity of n-3 PUFA has resulted in theory that n-3 PUFA may be beneficial in the management of a variety of chronic inflammatory diseases summarized in Table 2., some of which will be discussed below in some more detail.

Fish oils particularly have been consistently demonstrated to possess anti-inflammatory potential in animal models of inflammatory bowel disease (IBD) (Calder 2008, Innis and Jacobson 2007, Dignass et al. 2004). Moreover, in the number of clinical trials in IBD patients, improved gut histology, decreased disease activity, decreased use of corticosteroids and decreased relapse following dietary consumption of n-3 PUFA have been reported (Belluzzi A et al 1996, Trebble et al. 2004, Shimizu et al. 2003). However, due to discrepancies in outcome results and doses in these studies, more studies are warranted to proof the therapeutic potential of n-3 PUFA in IBD (Calder 2008).

**TABLE 2.** Therapeutic potential of n-3 PUFA supplementation on treatment and/or prevention of several common inflammatory conditions (not a comprehensive list).

Inflammatory condition / disease	Reference
Rheumatoid arthritis	Dawczynski et al. 2009
Inflammatory Bowel Disease	Dignass et al. 2004*
	Innis and Jacobson 2007*
Lupus	Simopoulos 2002*
Type 1 Diabetes	Merzouk et al. 2008
Type 2 Diabetes	Delarue et al. 2004*
Cystic fibrosis	Al-Turkmani et al. 2007
Childhood asthma	Biltagi et al. 2009
	Schachter et al. 2004*
Adult asthma	Surette et al. 2008
	Schachter et al. 2004*
Allergic disease	Kremmyda et al. 2009*
	Furuhjelm 2009
Psoriasis	Wolters 2005*
Multiple sclerosis	Shapiro 2003*
Atherosclerosis	Allayee et al. 2009*
Obesity	Micallef et al. 2009
Trauma based inflammation	Waitzberg and Torrinhas 2009*

\* Review or meta-analysis

In asthma, arachidonic acid derived eicosanoids are produced by the local cells to promote inflammation (Calder PC 2006). In addition to direct proinflammatory potential of the eicosanoid, these modulators do promote Th2 cell proliferation that are known to further potentiate allergic inflammation (Miles et al. 2003) and IgE production (Roper and Phipps 1994). This is the general basis for the hypothesis suggesting the causal effects of increased n-6 PUFA and decreased n-3 consumption in western world and increased asthma (Black and Sharpe 1997, Kankaanpää et al. 1999). This hypothesis is in fact supported by the epidemiological studies (Hodge et al. 1996, Dunder et al. 2001). Accordingly, several randomized, placebo-controlled, double-blinded studies of n-3 PUFA supplementation in asthma have been reported and meta-analyzed (Woods et al. 2002, Schachter et al. 2004). In summary, these studies have shown that the efficacy of n-3 PUFA supplementation in treatment of asthma warrant more studies. Still, the results from some studies indicate that there may be subgroups whose inflammatory condition is significantly improved by n-3 PUFA supplementation (Nagakura et al. 2000, Schubert et al. 2009, Focke et al. 2005).

Kremmyda and coworker's (Kremmyda et al. 2009) have systematically reviewed the previous epidemiologic studies investigating associations between fish intake in pregnancy, lactation, infancy, and childhood, and atopic outcomes in infants and children as well as applicable intervention studies with fish oil supplements in similar groups. Compilation of these epidemiological studies does show protective associations between maternal fish intake during pregnancy on atopic or allergic outcomes in infants/children. However, such a protective action was less evidenced (in 9 out of 14 studies) when fish intake was assessed during infancy or childhood and compared to atopic outcomes in those infants/children (Kremmyda et al. 2009). Clearly, the fish oil supplementation during pregnancy and lactation or during infancy or childhood shifted the overall PUFA status of infants and children from n-6 predominance toward higher n-3 PUFA status (Kremmyda et al. 2009). Also, when fish oil was consumed during the pregnancy, some anti-inflammatory immunologic changes can be seen in blood (Denburg et al. 2005), and these changes may even be persistent (Lauritzen et al. 2005b). Fish oil supplementation during pregnancy may also reduce sensitization to common food allergens and reduce prevalence and severity of atopic dermatitis in the first year of life, with a possible persistence until adolescence with a reduction in eczema, hay fever, and asthma (Dunstan et al. 2003). However, there is still too much inconsistency in the reports and thus the efficacy of fish oil in the treatment of children with allergic diseases remains inconclusive (Kremmyda et al. 2009). Intriguing question remains to be whether very early changes (i.e. before birth) in the fetal intestinal structural membrane lipids influence intestinal functions of the infant by altering the response to the introduction of dietary antigens, luminal bacteria or their metabolites and thus resulting in predisposition of the infant to the chronic inflammatory diseases.

## 2.2 PROBIOTICS

According to the currently adopted definition by Food and Agriculture Organisation and World Health Organisation, probiotics are '*Live microorganisms which when administered in adequate amounts confer a health benefit on the host*' (FAO/WHO 2009). Two genera, *Bifidobacterium* and *Lactobacillus*, are abundant in the intestinal microbiota and subsequently these have also become the most widely used probiotics. In the above-referred critical definition, the viability of the microorganisms is emphasized (Sanders et al 2007). However, it may be that under certain circumstances nonviable probiotics may be effective as well. For example, the recent data indicate that some nonviable probiotic preparations could protect



against infections and modulate immunity in animal models (He et al. 2005, Villena et al. 2009). Even though the use of nonviable probiotics over viable preparations could bring some important technological advantages (e.g. longer shelf life, easier transport, storage, and handling), the importance of viability remains to be fully proven (Salminen et al. 2005).

### **2.2.1 The Concept of Normal Gut Microbiota**

The bacterial inhabitants of the human gastrointestinal tract (GI tract) constitute a complex ecosystem. Early papers describe that 400 to 500 species inhabit the human intestinal tract, but this value originated from statistical analyses: only 113 species were isolated (i.e. were able to be cultivated with traditional culture-based techniques) from 20 different samples (Moore and Joldeman 1974). It is now generally agreed that a significant proportion of the gut microbial diversity has not been realized based on these traditional methodologies (Suau et al. 1999). Since normal microbiota plays a decisive role in the health and physiological function of the host (Salminen et al. 2005), a thorough understanding of the predominant microbiota (at different stages of its development) within the human gut is pivotal for understanding how the normal flora may provide colonization resistance and stimulate immune responses. As the modulation of normal microbiota is one of the targets of the use of probiotics and prebiotics for improved health (Ouweland et al. 2002, Isolauri and Salminen 2008), accurate methods for monitoring bacterial changes are essential (Suau et al. 1999, Rajilić-Stojanović et al. 2009).

The primary role the intestinal microbiota is to ferment dietary carbohydrates, proteins and amino acids that have escaped digestion in the upper GI tract (Cummings 1998, Cummings et al. 2001). The establishment of colonic microbiota also provides protection against infections, strengthen the gut barrier functions (e.g. against antigens) and modulate immune system (Isolauri and Salminen 2008). In addition, colonic microbiota is involved in vitamin B and K synthesis and in the metabolism / immobilization of xenobiotics (Baker 1981, Kankaanpää et al. 2000, Halttunen et al. 2008). Thus, the management of the intestinal microbiota offers a potential way to improve many conditions related to human health.

In the development of microbiota two major stages can be distinguished: (i) the first inoculum with microbes derived from flora within the mother's birth canal during the delivery or from local environment (neonatal intensive care facility, hospital staff etc.), and (ii) the successive

establishment of intestinal microbiota (Salminen et al. 2005). In vaginally delivered newborns, the first bacteria to colonize the intestine are derived from mother's vagina, intestine, and skin and from the local environment (Tannock et al. 1990, Matsumiya et al. 2002, Fanaro et al. 2003). The importance of vaginal delivery in the establishment of intestinal microbiota in newborn is highlighted by the findings demonstrating that immediately after birth in 52% of cases the lactobacilli were present both in infant's mouths and in their mother's vagina (Rotimi and Duerden 1981). Another evidence for the pivotal role of vaginal microbiota is the delayed gut colonization in infants born by caesarean delivery (Bennet and Nord 1987, Hällström et al. 2004, Mitsou et al. 2008), and this delay may be persistent up to 6 months of infant's life (Grönlund et al. 1999). Consequently, the predominance pattern of the mother's vaginal and intestinal microbiota has a significant influence on the initial microbiocenosis of her newborn.

The differences in the species composition thereafter are largely controlled by environmental and dietary factors but genetic background may also influence (Benno and Mitsuoka 1986). In developed countries, infants are subjected to high levels of hygiene during nursing. This degree of sterility may result in less complex microbiota normally dominated by one or a few different enterobacterial strains (Adlerberth et al. 2006). Particularly, antibiotic treatments have been shown to delay the establishment of anaerobic microbiota (Bennet and Nord 1987, Bennet et al. 2002). Profound differences also exist in response to infant's feeding. The intestinal microbiota of formula-fed infants is more diverse containing bifidobacteria, bacteroides, clostridia and streptococci, whilst bifidobacteria are dominant in microbiota of breastfed infants (Fanaro et al. 2003, Benno et al. 1984, Harmsen et al. 2000). Interestingly, human breast milk has also been recognized as a source of bacteria (Martin et al. 2003, 2007) explaining repeatedly reported differences in microbiota of breast-fed and formula fed infants. The next major dietary shift is the introduction of solid foods that have been shown to result in sharp increase in numbers of enterobacteria, enterococci and *Bacteroides* species in breastfed infants, whereas these changes are only moderate in the formula-fed infants (Favier et al. 2002). At 12 months of age, the anaerobic bacterial populations of the intestine of both above mentioned feeding groups begin to resemble those of adults in number and composition (Stark and Lee 1982, Suau et al. 1999, Salminen et al. 2005), suggesting that the window of opportunity for probiotics to modulate intestinal microbiota is within the first year of life.

The normal human microbiota is a complex ecosystem that is dependent on enteric nutrients for establishing colonization. The development of the gut microbiota can be modulated by (i) administration of defined microbial cell preparations or components of microbial cells (probiotics) in sufficient numbers (Isolauri et al. 2004) or by (ii) non-digestible food ingredients (prebiotics) that selectively stimulate the growth and/or metabolism of one or a limited number of bacteria in the gut (Fanaro and Vigi 2008) or by (iii) other protective nutrients such as breast milk (Schrezenmeir and deVrese 2001, Bomba et al. 2002). Both probiotics and prebiotics are targeted toward beneficial microbes and thus tend to operate through that part of the gut flora containing lactic acid bacteria (inc. bifidobacteria). Lactobacilli (e.g. *L. acidophilus*, *L. paracasei*, *L. rhamnosus* and *L. plantarum*) and bifidobacteria (e.g. *B. bifidum* and *B. longum*) are the most commonly used probiotics, the feeding of which introduce more lactobacilli and bifidobacteria into the intestine (Sanders 2003). However, probiotics gradually disappear from feces when oral supplementation is discontinued indicating that long-term colonization with the probiotics did not occur (Salminen et al. 2005, Gueimonde et al. 2005). In order to maintain or increase the number of lactobacilli and bifidobacteria in the intestinal tract, prebiotics are needed in the diet. For example, administration of nondigestible oligosaccharides such as raffinose, fructo-oligosaccharides, inulin, galactosylactose, isomalto-oligosaccharides, or transgalactosyloligosaccharides increases the number of endogenous bifidobacteria and lactobacilli (Fuller and Gibson 1997, Saulnier et al. 2009). There are also other dietary components such as human milk and polyunsaturated fatty acids that may also promote gastrointestinal maturation (Martin et al. 2003, Bomba et al. 2002).

### 2.2.2 Selection Criteria of Probiotics

Probiotics are expected to possess several desirable properties in order to exert their beneficial effects. The relevant selection criteria for probiotics include (i) history of being non-pathogenic (even in immunocompromised hosts), (ii) human origin (especially if intended for human use), (iii) acid and bile stability, (iv) *in vitro* demonstrable properties (such as adhesion to mucosal surfaces, immunomodulatory activity, antagonistic activity, and bacteriocin production), (v) clinically demonstrated health effects and (vi) good technological properties (Tuomola et al. 2001, Salminen et al. 2005, Sanders 2003). As a general guideline, WHO has published in 2002 a scheme for the evaluation of probiotics for the food use (FAO/WHO 2002) presented in Figure 4.

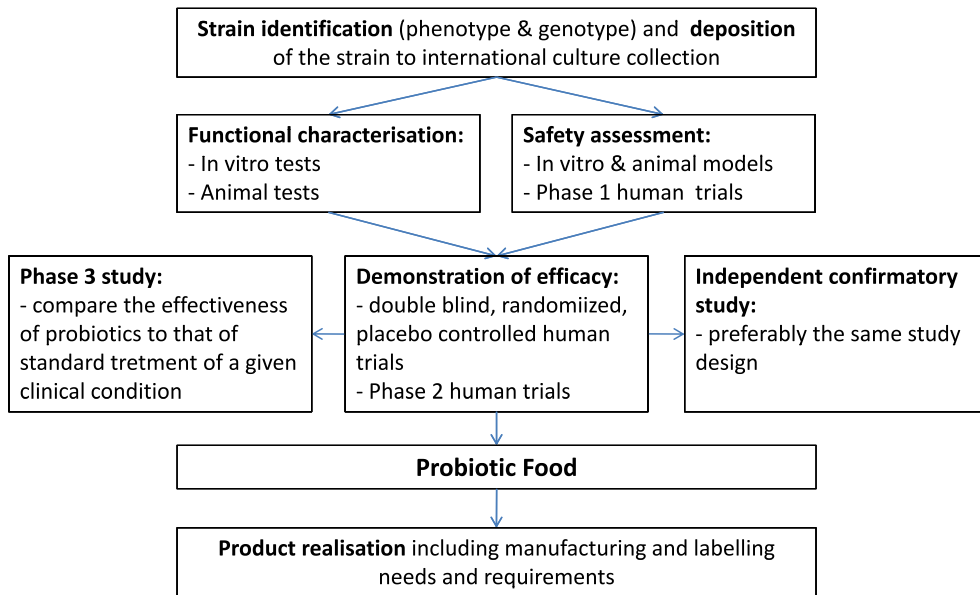

**FIGURE 4.** Guidelines for evaluation of probiotics for food use (modified from Joint FAO/WHO guidelines 2002).

Even though a potential probiotic strain does not need to fulfill all above described selection criteria, the safety issue is of outmost importance. *Lactobacillus*, *Leuconostoc* and *Pediococcus* species have been consumed throughout human history and bifidobacteria are predominantly present in GI tract of breast-fed infant (Ishibashi and Yamazaki 2001). As the reports demonstrating harmful effects of probiotics are rare, their safety has not been questioned and they are most commonly given generally-regarded-as-safe status (Isolauri and Salminen 2008, Sanders 2003). However, some commonly used probiotics bacteria have also been isolated from various types of infective lesions: bacterial endocarditis and bacterimia, and various other infections (Husni et al. 1999, Salminen et al. 2004, Tommasi et al. 2008). The extremely low number of cases of bacterimia related to the use of probiotics supported by epidemiologic evidence suggests no population based increase in risk on the basis of usage data (Salminen M et al. 2002). Moreover, there have been several controlled clinical trials on the use of probiotics that demonstrate safe use (Salminen et al. 2004, Snyderman 2008).

Adhesion ability of a strain to the intestinal mucosa is another main selection criterion for probiotics (Tuomola et al. 2001). Even though adhesion to mucosal surfaces is a pre-requisite for the subsequent colonization, probiotics in use do not appear to colonize a host permanently but only transiently (Salminen et al. 2005, Gueimonde et al. 2005). The human microbiota has been shown to change during the lifetime. The most drastic changes take place in early childhood (the establishment of a stable microbiota) and in elderly (decrease in bifidobacteria). Interestingly, there appears to be correlation between *in vitro* adhesion and colonization of bifidobacteria (Tuomola et al. 2001). Ouwehand and co-workers found especially low bifidobacteria adhesion to intestinal mucus isolated from elderly subjects (Ouwehand et al. 1999), suggesting that reduced adhesion may be one explanation for the low bifidobacteria numbers in elderly. Moreover, the adhesion ability of specific probiotic strains also correlates with the duration of the rotavirus diarrhea. *Lactobacillus* GG and *L. reuteri*, both found to be adhesive (Tuomola and Salminen 1999, Kirjavainen et al. 1998), have also been shown to shorten rotavirus diarrhea (Shornikova et al. 1997, Majamaa et al. 1995), whereas moderately adhesive (Greene and Klaenhammer 1994) *L. delbrueckii* ssp. *bulgaricus* did not (Majamaa et al. 1995).

### 2.2.3 Mechanisms of action of probiotics in the gut

During the first few days of life, the intestine is rapidly colonized by bacteria, which probably possess a dual significance in the context of development of gut defense mechanisms. The demonstration that in the absence of the intestinal microbiota antigen transport across the gut mucosa is increased indicates that gut microbiota is an important factor in the development of intestinal defense barrier (Isolauri and Salminen 2008). Intestinal bacteria can also process certain nutrient (Musso et al. 2009), regulate intestinal angiogenesis (Stappenbeck et al. 2002), influence the number and distribution of the gut associated lymphoid tissue (GALT) cell populations (Rhee et al. 2005), induce oral tolerance and mucosal immunity (Nagler-Anderson 2000, Sudo et al. 1997), and diversify the premature antibody repertoire (Rhee et al. 2004).

Probiotic bacteria have been shown to alleviate disease states that are characterized by altered intestinal microbiota and impaired gut barrier (Salminen et al. 1996 and 2005). For example, prolonged cow milk challenge in suckling rats increased the gut permeability (assessed using Ussing chamber technique), whereas *Lactobacillus* GG in milk reversed this disorder (Isolauri

et al. 1993). Similarly, the same probiotic strain was shown to decrease the uptake of horseradish peroxidase in suckling rats with rotavirus (Isolauri et al. 1993b). Processing of dietary proteins and T-cell suppression are the deciding elements to evoke systemic hyporesponsiveness to ingested protein antigens. The evidence suggests that probiotic bacteria may modify immunomodulatory properties of native food antigens. For example, bovine caseins modified by enzymes of *Lactobacillus* GG have been shown in vitro to suppress lymphocyte proliferation in healthy adults (Pessi et al. 2001) and downregulate IL-4 production in atopic subjects (Sütas et al. 1996). This bacterial ability to degrade food antigens into tolerogenic antigens has also been demonstrated to be antigen specific (Pessi et al. 1998). The results indicate that probiotics can normalize the gut permeability and modify the structure of potentially harmful antigens thereby altering the mode of their immunogenicity (Isolauri et al. 2001).

The fundamental idea with probiotics has always been to alter the aberrant intestinal microbiota towards a normal microbiota that would be beneficial to the host (Ouwehand et al. 2002, Bomba et al. 2002). By increasing the number of lactobacilli and/or bifidobacteria, levels of certain less desirable bacterial genera, such as coliforms and clostridia can be decreased. The mechanisms by which probiotics modulate composition of intestinal microbiota may include the compensation for the adhesion sites and nutrients, and the production of antimicrobial substances (Salminen et al. 2005). In addition, probiotic consumption not only results in an increase of the particular consumed probiotic but also may also induce the growth of other potentially beneficial genera (Ohashi et al. 2007) and enhance nonspecific host resistance to microbial pathogens (Ouwehand et al. 2002). Non-specific host-defense responses are induced by a variety of stimuli and are activated rapidly. Phagocytosis is responsible for the recruitment of immunocompetent cells and generation of inflammatory response, the phenomenon also seen in atopic subjects (Isolauri et al. 1997, Crittenden and Bennett 2005). Several strains of live lactic acid bacteria have been shown to induce *in vitro* the release of proinflammatory cytokines, tumor necrosis factor- $\alpha$ , IL-6 and IL-12, reflecting stimulation of nonspecific immunity (Ghadimi et al. 2008), whereas some studies have shown that probiotics or homogenates derived from them (i.e. non-viable probiotic prepreparates) do possess antiproliferative activities and down-regulate IL-2 and IL-4 production of peripheral blood mononuclear cells (Kankaanpää et al. 2003), probably mediating these immunomodulatory effects via several specific innate immune receptors (Ishii et al. 2008). In humans, enhanced phagocytic activity of peripheral blood leukocytes has also been reported

in humans by *Lactobacillus johnsonii* strain La1 (Donnet-Hughes et al. 1999). Even though *Lactobacillus* GG did possess similar activation potential, this potential was subject group specific; suppression of phagocytosis in milk-hypersensitive subjects but stimulation in healthy (Pelto et al. 1998). Oral bacteriotherapy with probiotics has also been shown to stabilize the immunologic barrier of gut mucosa by reducing the generation of local proinflammatory TNF- $\alpha$  (Majamaa and Isolauri 1997), by reinforcing the systemic production of IFN- $\gamma$  with physiological protective effects in the gut (Ullisse et al. 2001) and by stimulating antigen specific IgA antibody responsiveness via promoting transforming growth factor (TGF)  $\beta$ 2 (Rautava et al. 2006). Therefore, the immunomodulating effects of probiotic bacteria may depend on the immunologic state of the host. Moreover, strains that have been shown to survive in the GI tract, adhere to the gut mucosa and persist above a critical level seem to be more efficient in stimulating non-specific immunity (Tuomola et al. 2001).

Specific immune responses can be classified into two major categories, humoral immunity and cellular immunity. Translocation of probiotics could lead to the activation of the GALT, which results, in turn, in mucosal soluble IgA production (Rhee et al. 2004). Soluble IgA inhibits colonization of pathogens and penetration of potentially harmful luminal antigens. Especially, soluble IgA production can be induced by oral immunization, as shown in studies demonstrating an increase in systemic and mucosal IgA responses to dietary antigens following oral administration of lactobacilli (*Lactobacillus* GG and *Bifidobacterium lactis* Bb-12) (Rautava et al. 2006). Similarly, an increased humoral immune response including an increase in rotavirus-specific antibody-secreting cells in the IgA class has been detected in children with acute rotavirus diarrhea who received *Lactobacillus* GG during the acute phase of diarrhea compared with controls (Majamaa et al. 1995). The development of humoral immune mechanisms has been linked to mode of delivery and subsequent changes in microbiota; the differences in the microbiota of vaginally born infants and infants born by caesarean section were associated with maturation of humoral immune mechanisms (Grönlund et al 2000). Particularly, infants harboring *Bacteroides fragilis* and, to a lesser extent, bifidobacteria had more circulating IgA- and IgM-secreting cells. Similarly, the compositional microbiota differences were observed in infants in whom atopy was or was not to be developed (Kalliomäki et al. 2001). Thus, qualitative differences in the composition of the microbiota might affect the immunological homeostasis. The impact of gut microbiota on the maturation of the gut immune defense culminates in early infancy, when the mode of

immune responsiveness to antigens is consolidated (Salminen et al. 2005, Isolauri and Salminen 2008).

Probiotics have also been demonstrated to modulate cellular immunity. Lymphocyte proliferation to T cell mitogens have been enhanced in mice fed yoghurt containing live lactic cultures (De Simone et al. 1987). Likewise, *L. acidophilus* feeding has been shown to enhance *ex vivo* basal splenic lymphocyte proliferation in mice (Kirjavainen et al. 1999). In contrast to these immunostimulatory activities, several studies also indicate that probiotic bacteria may possess immunosuppressive activities. *L. casei*, *L. gasseri*, and *L. rhamnosus* were shown to inhibit both basal proliferation and mitogen-induced T cell proliferation (Kirjavainen et al. 1999b). Similarly, heat-stable, cytoplasmic extracts derived from candidate probiotic bacteria suppressed mitogen stimulated peripheral lymphocyte proliferation (Pessi et al. 1999), and down-regulated IL-2 and IL-4 production of peripheral blood mononuclear cells and inhibited activation receptor expression on stimulated T lymphocytes (Kankaanpää et al. 2003) indicating that probiotic may be used to generate biologically nonviable, yet immunologically effective immunomodulatory components. In addition, *L. casei* has been shown to down-regulate IL4, IL5 and antigen-induced IgE production (Shida et al. 1998), and aberrant IgE response by germfree mice could be corrected by the reconstitution of microbiota at the neonatal stage, but not at later age (Sudo et al. 1997). The enhanced IL-10 production in atopic children following the oral bacteriotherapy with *Lactobacillus* GG and *Bacillus clausii* further substantiates the anti-inflammatory properties of specific probiotics (Pessi et al. 2000, Ciprandi et al. 2005). Above summary of results indicate that the maturation of intestinal microbiota at early age plays a crucial role in the development of oral tolerance and this may be modulated by specific strains of probiotics.

#### **2.2.4 Potential Health Benefits of Probiotics**

A number of health-related effects of probiotics have been documented (Salminen et al 2005, Sanders 2003, de Vrese and Schrezenmeir 2008). The clinical endpoints for probiotic studies investigated so far are listed in Table 3.



**TABLE 3.** Examples of studied clinical endpoints for probiotic therapies (the list of endpoint and references is not comprehensive but demonstrative).

Clinical endpoint	Reference
Inflammatory bowel disease (incl. Crohn's disease and ulcerative colitis)	Mitsuyama 2008* Madden 2002*
allergy (atopic eczema, milk allergy, asthma)	Isolauri and Salminen 2008* Kalliomäki et al. 2003, 2007
colon cancer	Rafter 2003* Hatakka et al. 2008 El-Nezami et al. 1998
diarrheal diseases	Dubey et al. 2008 Szajewska et al. 2001 McFarland 2006*, 2007*
lactose intolerance (incl. milk hypersensitivity)	Montalto et al. 2006* Vesa T et al. 2000*
Diabetes (both Type 1 & 2)	Ljungberg et al. 2006 Cani and Delzenne 2009* Luoto et al 2010b

\* Meta-analysis or review

Despite the abundance of reports showing the importance of probiotic supplementation, only a limited number of probiotics have been validated using clinically relevant endpoints. For the most cases, the reports are 'preliminary' and it is hard to establish the total evidence including full spectrum of *in vitro* and animal studies linked to human data. The treatment and/or prevention regimen for which probiotics have recently gotten an "A" recommendation (Floch et al 2008) will be discussed in more detail below.

Dietary studies have suggested that consumption of yogurt may reduce some clinical symptoms of allergy in adults with atopic rhinitis or nasal allergies, especially among elderly by alleviating Th2 kind of responses (Cross et al. 2001). As an example, *Lactobacillus*-fortified yogurt consumption showed a longitudinal trend toward reduced eosinophilia and increased IFN- $\gamma$  production in adult asthmatics, though normal yogurt did not affect atopy or immune parameters (Wheeler et al. 1997). In addition to studies on adults, it has been suggested that children later developing allergy possess an aberrant intestinal microbiota (Kalliomäki et al. 2001) - an imbalance that probiotics could potentially correct. Indeed,

especially *Lactobacillus* GG and *Bifidobacterium* Bb-12 have shown preventative potential on allergy development (Majamaa and Isolauri 1997, Isolauri et al. 2000, Pessi et al. 2000, Kalliomäki et al. 2001b, 2003, 2007). In the study, Majamaa & Isolauri showed that probiotic supplementation significantly alleviated the extent and intensity of eczema, as well as reduced fecal alpha-1-antitrypsin and TNF levels of cow's milk-sensitive infants with atopic dermatitis. In another study, 27 exclusively breast-fed infants with atopic dermatitis were weaned to a hydrolyzed whey formula alone, or in combination with *Lactobacillus* GG or *Bifidobacterium* Bb-12 (Isolauri et al. 2000). The children's eczema after 2 months was scored in a blinded fashion using SCORAD system, and found to be significantly improved to nearly normal in both probiotic groups. This improvement was also paralleled by reduction of soluble CD4 in the serum and eosinophilic protein X in the urine (Isolauri et al. 2000). In atopy, IL-10 is suggested to possess anti-inflammatory effects via downregulation of IL-4 and *Lactobacillus* GG supplementation have been shown to augment IL-10 production in children with atopic dermatitis and cow's milk allergy (Pessi et al. 2000). Most recently, in a placebo-controlled, double blinded trial, supplementation of both mothers and infants with *Lactobacillus* GG was shown to significantly reduce the incidence of atopic disease at 2 years of age (23% of the probiotic group vs. 46% of the placebo group) (Kalliomäki et al. 2001). Moreover, there are two more longitudinal follow-up reports of the same study indicating that early probiotic therapy (pre- and postnatal) result in persistent reduction of atopy in children up to 7 years after the original therapy took place (Kalliomäki et al. 2003, 2007). Even though these results are very promising, conflicting data has also been published (Isolauri and Salminen 2008). For example, *Lactobacillus* GG, one of the most studied and potent probiotic, failed to show any beneficial effects in adolescents and adults having birch pollen allergy (Helin et al. 2002), *Lactobacillus* GG supplementation during pregnancy and early infancy was reported to neither reduce the incidence nor altered the severity of atopic dermatitis in double-blind, placebo controlled prospective trial (Kopp et al. 2008) and Wheeler and co-workers reported no changes in clinical asthma patient following consumption of *Lactobacillus acidophilus* fortified yoghurt (Wheeler et al. 1997). These findings also highlight the importance of therapy timing, study design and strain selection; (i) therapies should be carried out at time when the intestinal mucosa is known to be particularly responsive to microbial stimulus, i.e. at prenatal or neonatal stages of infant (adults have already acquired their tolerance), (ii) study designs and used formulations may have drastic effect on the output of the study, and (iii) potential beneficial effects of probiotics are highly strain specific. The usefulness of probiotics in treatment of childhood allergy and eczema is

now widely accepted (Floch et al. 2008) and specific probiotics (e.g. *Lactobacillus* GG and *Bifidobacterium lactis*) are recommended in infants and children for the treatment and prevention of allergic disorders with intestinal involvement (Rosenfeldt et al. 2004, Viljanen et al. 2005, Kalliomäki et al. 2001, 2003, 2007, Abrahamsson et al. 2007). However, although the evidence that probiotics may prevent the development of atopy and reduce allergic symptoms in existing atopic disease is accumulating for specific strains, according to recent meta-analyses, the hygiene hypothesis remains still to be confirmed (Boyle et al. 2009, van der Aa et al. 2009).

The use of antibiotics decreases the indigenous gut microbiota, thus reducing the colonization resistance, and the fermentation capacity of the colon thereby resulting in antibiotic-associated diarrhea (AAD). Randomized, double blind, placebo-controlled studies have proven the efficacy of the oral administration of *Saccharomyces boulardii* to decrease the risk of AAD and significantly shorten the durations of AAD (Surawicz et al. 1989). A clinical trial by Ruszczyński and co-workers assessed the efficacy of three *L. rhamnosus* strains in the prevention of AAD in double-blind, randomized, placebo-controlled trial of 240 children (Ruszczyński et al. 2008); 20 patients in the placebo group had diarrhea compared to nine in the probiotic group. Moreover, various meta-analyses have shown the efficacy of probiotics in the prevention of AAD (D'Souza et al. 2002, McFarland 2006). Evidence also exists for the efficacy of probiotics (*L. bulgaricus*, *L. acidophilus*, *Lactobacillus* GG, bifidobacteria, streptococci) in the prevention of traveler's diarrhea (Hilton et al. 1997, Oksanen et al. 1990). In addition to the specific studies, a meta-analysis of several hundreds of studies has concluded that probiotics are safe and effective for prevention of traveler's diarrhea (McFarland 2007), despite the number of contradictory studies. These variations have generally been justified by several factors such as differences in populations studied, type of probiotics used, the duration of treatment, travel destination, probiotic viability during the trip and travelers compliance with treatment (Eamonn et al. 2009).

The use of the probiotics in the treatment and prevention of viral diarrhea is well documented (Guandalini 2008). Especially, *Lactobacillus* GG has been consistently demonstrated to reduce the duration of rotavirus-associated diarrhea in randomized trials (Isolauri et al. 1994, Guandalini et al. 2000, Szajewska et al. 2001). Several other probiotics (e.g. *Lactobacillus reuteri* and *Bifidobacterium bifidus* Bb-12) may also be potential candidate bacteria when oral bacteriotherapy for viral diarrhea is considered (Shornikova et al. 1997, Saavedra et al. 1994).

A positive impact of probiotics (in terms of virus-originated diarrhea) in children of day-care centers and in undernourished Peruvian children suggesting that regular supplementation with probiotics may be beneficial (Oberhelman et al. 1999, Hatakka et al. 2001). Even though there have been some promising studies using the probiotic yeast, *Saccharomyces boulardii* (Surawicz et al. 2000, Ooi et al. 2009), the adequate evidence is lacking to recommend the use of probiotics in the prevention or treatment of *C. difficile* (Eamonn et al. 2009, Rupnik et al. 2009).

### **2.3 SUMMARY OF LITERATURE REVIEW**

The prevalence of inflammatory based diseases, such as atopy, has increased especially in developed countries within the last decades. Two primary hypotheses have been proposed to explain this phenomenon; the hygiene hypothesis and the hypothesis based on dietary evolution. In particular, the reduced early exposure to microbes and an increase in the amount of polyunsaturated fatty acids (especially n-6 PUFA) in the diet have been proposed. As discussed in this literature review, both factors have been shown to possess potential health benefits in terms of prevention and treatment of inflammatory diseases. Moreover, these beneficial effects seem to be derived via similar mechanisms (e.g. modulation of non-specific and specific immunity, microbiota and permeability). It is also evident that the modulatory power of these two factors has nearly exclusively investigated individually. The hypothesis of the present study was to demonstrate that PUFA and probiotics are not separate entities as such but do interact with each other.

### **3 AIMS OF THE PRESENT STUDY**

The goals of the present study were to characterize the interactions between PUFA and probiotics. More specifically, the aims were:

- 1) to investigate whether maternal diet and atopic status influence the PUFA composition of breast milk and serum fatty acids of infants
- 2) to investigate whether the fatty acid absorption and utilization by the atopic infants is affected by supplementation of infant formula with probiotic bacteria.
- 3) to assess whether specific probiotic strains could incorporate exogenous free PUFA into bacterial lipids and how these changes influenced the physical properties of given bacteria.
- 4) to assess how different free PUFA in growth media influence the functional properties of probiotics by investigating the adhesion properties to mucus and epithelial cells as well as bacterial growth.

## 4 SUBJECTS, STUDY DESIGNS AND ETHICS

### 4.1 Study I

Study population design is shown below (Figure 5). Allergic mothers had a confirmed asthma, allergic rhinoconjunctivitis, or atopic eczema and children were classified as atopic if at least one positive skin prick test together with atopic eczema or food allergy were recorded (Hanifin, 1987).

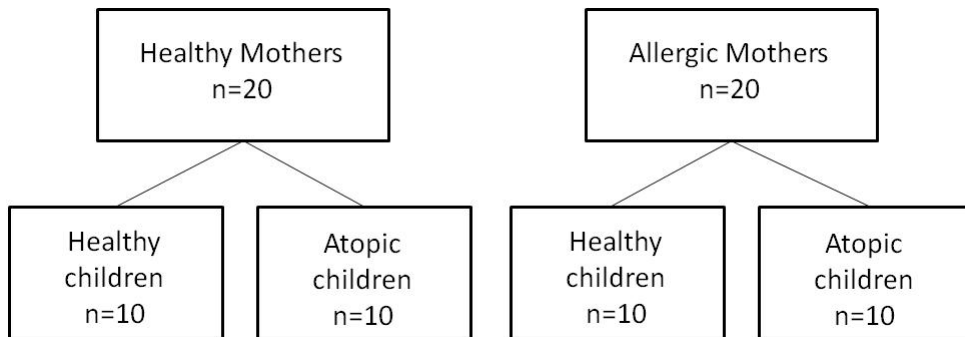

**FIGURE 5.** Population design of Study I.

Breast milk samples were collected when the children were 3 months old. At the same time, completed food records were collected, and blood samples from infants were drawn by venous puncture.

Altogether 28 (18 allergic and 10 healthy) out of 40 mothers completed food records adequately with household measures on four consecutive days as described previously (Isolauri et al 1999). The mothers chose these days freely, and they were regarded to reflect the period of exclusive breastfeeding.

Informed written consent was obtained from the mothers before the study. The Joint Ethical Committee of University of Turku and Turku University Central Hospital in accordance with the Helsinki Declaration approved the study.

## 4.2 Study II

The study involved 15 infants (median age of enrolment 5 month) referred to pediatric clinic on the basis of atopic eczema; all fulfilled the Hanifin criteria for atopic eczema (Hanifin 1991). All the infants were exclusively breastfed before the eczema symptoms having had no exposure to any infant substitute.

Infants were divided (randomized double-blind study design) into three groups receiving infant formula with or without probiotic bacteria; group A received extensively hydrolyzed infant formula, group B received the same formula supplemented with *Lactobacillus* GG and group C the same formula supplemented with *Bifidobacterium* Bb12. All formulas were well tolerated by infants.

Baseline characteristics of the study population, the amount of formulas consumed by the infants and the weight gain is shown in Table 4.

Blood samples were collected (EDTA-plasma) at the first clinical examination before the start of study period and on the control clinical examination.

Informed consent was obtained from the infants' parents and the Tampere University Hospital Committee on Ethical Practice approved the study.

## 4.3 Study III

The three lactobacilli strains, widely used as probiotics or dairy starter culture strains, were grown anaerobically in MRS broth supplemented with linoleic acid (18:2 n-6),  $\gamma$ -linolenic acid (18:3 n-6), arachidonic acid (20:4 n-6),  $\alpha$ -linolenic acid (18:3 n-3), or docosahexaenoic acid (22:6 n-3) or without any PUFA supplementation.

After culturing phases, the influence of the PUFA supplementation on the bacterial cell fatty acid compositions (with PUFA dose of 5  $\mu\text{g}$  / mL) and physicochemical characteristics (hydrophobicity and electron donor-acceptor nature) of probiotics (with PUFA doses of 5 and 20  $\mu\text{g}$  / mL) were investigated.

**TABLE 4.** Baseline characteristics of the study population of the Study II.

<b>Subject demographics</b>							
Group	Age of study entry	Duration of treatment	weight at entry	weight gain (entry - 2months)	amount consumed / day	formula	sex (female + male)
Group GG (n=5)	4.5 (2.0) months	4.4 (1.7) months	7076 (1766) g	1453 (630) g	76 mL/kg		3 + 2
Group Bb-12 (n=5)	5.7 (2.2) months	7.3 (0.7) months	7662 (1411) g	1283 (828) g	73 mL/kg		2 + 3
Group placebo (n=5)	5.6 (2.1) months	5.7 (2.0) months	7230 (1574) g	1492 (520) g	75 mL/kg		3 + 2
total mean (n=15)	5.2 (2.0) months	5.8 (1.9) months	7323 (1494) g	1409 (629) g	75 mL/kg		8 + 7



#### 4.4 Study IV

In the first part of Study IV, three lactobacilli strains, widely used as probiotics or dairy starter culture strains with proven *in vitro* adhesion properties (Kirjavainen et al. 1998, Tuomola and Salminen 1998, Tuomola et al. 2001), were grown in the presence of linoleic (18:2 n-6),  $\gamma$ -linolenic (18:3 n-6), arachidonic (20:4 n-6),  $\alpha$ -linolenic (18:3 n-3), or docosahexaenoic acid (22:6 n-3) after which bacterial concentrations and bacterial viability were assessed *as per* function of PUFA doses of 5, 10, 20 and 40  $\mu\text{g} / \text{mL}$ .

In the second part of Study IV, the same bacteria were grown to the late logarithmic phase in MRS broths supplemented with the same PUFAs as above. The effect of PUFA at varying concentrations in growth medium (PUFA doses of 10, 20 and 40  $\mu\text{g} / \text{mL}$ ) was assessed as a function of mucus adhesion properties of a given bacteria.

In the third part of Study IV, the effects of PUFA on Caco-2 cells were investigated by culturing Caco-2 cells in medium supplemented with either linoleic acid,  $\gamma$ -linolenic acid, arachidonic acid,  $\alpha$ -linolenic acid, or docosahexaenoic acid (and control). The effects were assessed as function of bacterial adhesion to differentially grown Caco-2 cells.

## 5 MATERIALS & METHODS

Details of materials and methods are described in the original publications I-IV.

### 5.1 Bacteria and culture conditions

Bacteria used in the different studies and their sources are shown in Table 5. De Man, Rogosa, Sharpe (MRS) -broth (Merck, Darmstadt, Germany) was supplemented with or without linoleic (18:2  $\omega$ -6),  $\gamma$ -linolenic (18:3  $\omega$ -6), arachidonic (20:4  $\omega$ -6),  $\alpha$ -linolenic (18:3  $\omega$ -3), or docosahexaenoic acid (22:6  $\omega$ -3) at final concentrations of 5 (III, IV), 10 (IV), 20 (III, IV), and 40 (IV)  $\mu$ g / mL. The range of PUFA concentrations used in the studies has been previously demonstrated to be strain-dependently antibacterial (Kodicek and Worden 1945, Kabara et al 1972) and physiologically relevant (Champon 1996).

Bacteria were grown anaerobically in different MRS broths at 37 °C with gentle agitation to facilitate mixing during the incubation period. In all studies (III and IV), bacteria were grown to logarithmic phase, i.e. 18-24 hours at conditions described above.

The fatty acid composition of non-supplemented MRS growth medium was also analyzed based on methodologies described by Christie (1982) and Yang et al. 1999 (Table 6). Even though MRS medium is known to possess fatty acids (e.g. oleic acid; in the form of Tween-80), this medium was selected for this study since the Tween-80 has been shown to be essential growth factor for lactobacilli (Partanen et al. 2001). Moreover, this particular medium is the most commonly used medium in lactobacilli research; the evaluation of the relevance of the present results necessitates the use of this medium.

### 5.2 Infant formulas

The bacteria were selected for the study based on available data concerning their efficacy and safety (Isolauri et al 1989, Saavedra et al. 1994). The concentrations of probiotics in the formulas for *Lactobacillus* GG and *Bifidobacterium* Bb12 were  $3 \times 10^8$  and  $1 \times 10^9$  colony-forming units (CFU) / g, respectively. For the purpose of the study, it was pivotal to know the fatty acid profile of the basic study formula (Table 7).

**TABLE 5.** Bacteria used in the studies

Bacteria	culture collection#	Study	Source
<i>Lactobacillus</i> GG	ATCC 53103	II-IV	Valio Ltd., Helsinki, Finland
<i>Lactobacillus casei</i> strain Shirota	-	III-IV	Yakult Singapore Pty., Ltd.
<i>Bifidobacterium</i> Bb12	DSM 15954	II	Chr. Hansen A / S, Hørsholm, Denmark
<i>Lactobacillus delbrueckii</i> subsp. <i>Bulgaricus</i>	11842	III-IV	ATCC

**TABLE 6.** Fatty acid composition of MRS broth. Total fatty acid content 0.27 mg/mL.

Fatty acids	Rel. % (w/w)
12:0+14:0	0.5
16:0	4.7
18:0	1.5
19:0	0.4
20:0+22:0	0.4
16:1 n-7	1.0
18:1 n-9	65.9
18:1 n-7	2.0
20:1 n-9	2.1
22:1 n-9	0.5
18:2 n-6	0.1
18:2 c-9,t-11 / t-8,c-10 <sup>1</sup>	3.3
18:2 t-10,c-12 / c-11,t-13 <sup>1</sup>	3.1
20:3 n-3	0.2
22:6 n-3 + 24:1	0.6
Unidentified FA	13.6

<sup>1</sup> overlapping peaks in the chromatograms

**TABLE 7.** The fatty acid composition of extensively hydrolyzed infant formula (PeptidiTutteli, Valio Ltd., Helsinki, Finland) (Kaila 1999).

Fatty acids	Mean % by wt
Σ SFA	43,78
Σ MUFA	38,30
Σ n-6 PUFA	16,10
18:2 n-6	16,06
20:3 n-6	nd
20:4 n-6	nd
Σ n-3 PUFA	1,67
18:3 n-3	1,67
20:5 n-3	nd
22:6 n-3	nd

nd: not detected

### 5.3 Mucus adhesion

Human intestinal mucus was isolated from the faeces of healthy infants (n=11) and the bacterial adhesion to this mucus isolate was studied according to the method described by Kirjavainen et al 1998. For mucus adhesion assay, bacterial concentrations were adjusted to optical density of  $0,25 \pm 0,5$ ; approximately  $2,9 \times 10^7$  *Lactobacillus* GG,  $9,0 \times 10^7$  *L. casei* Shirota and  $6,9 \times 10^7$  *L. bulgaricus* were added to mucus adhesion.

Mucus adhesion results are expressed as mean (SD) of three independent experiments each performed in triplicate.

### 5.4 Caco-2 cell adhesion

The Caco-2 cells (ATCC HTB 37) were cultured in Minimal Essential Medium (MEM) supplemented with 1% MEM Non-essential Amino Acids Solution (Gibco BRL, New York, USA), 20 % heat-inactivated (30 min, 56 °C) foetal bovine serum, 2 mM L-glutamine, 2% sodium bicarbonate (7.5% NaH<sub>2</sub>CO<sub>2</sub>), 1% 0.1 M sodium pyruvate, 100 U ml<sup>-1</sup> penicillin and 100 mg ml<sup>-1</sup> streptomycin at 37 °C in an atmosphere of 10 % CO<sub>2</sub> / 90 % air.

Caco-2 monolayers were prepared in 24-well tissue culture plates, seeded at a concentration of  $1-3 \times 10^5$  cells / well to obtain confluence, and maintained for 2 weeks (fresh medium changed every second day).

To study the effects of PUFA on Caco-2 cells, MEMs were supplemented with either linoleic acid,  $\gamma$ -linolenic acid, arachidonic acid,  $\alpha$ -linolenic acid, or docosahexaenoic acid at final concentration of 10  $\mu\text{g} / \text{mL}$ . This PUFA concentration was selected according to preliminary growth and mucus adhesion findings of Study III.

One hour before bacterial adhesion assays, fresh non-supplemented MEM was changed. The adhesion of metabolically labeled bacteria to differentially cultured Caco-2 cells was assessed using the method described by Tuomola et al. 1998.

Caco-2 adhesion results are expressed as mean (SD) of three independent experiments each performed in triplicate.

### 5.5 Microbial adhesion to solvents

Microbial adhesion to solvents (MATS) was investigated by comparing bacterial cell affinities to polar and nonpolar solvents. A modified method described by Briandet et al. 1999 was utilized. Briefly, the following solvent pairs were used: i) chloroform (polar solvent) and tetradecane (nonpolar solvent), and ii) ethyl acetate (polar solvent) and octane (nonpolar solvent). Of the polar solvents, especially ethyl acetate is a strong electron donor solvent. The two nonpolar solvents were used to estimate the hydrophobicity properties of the lactobacilli, whereas the two polar solvents were selected for the estimation of the Lewis acid/base (i.e. electron donor/acceptor) characteristics. Comparing affinity to the polar acidic chloroform and to the nonpolar tetradecane assessed the basic characteristics of lactobacilli. In a similar fashion, comparing affinities to the polar ethyl acetate and to the nonpolar octane assessed the acidic characteristics of lactobacilli.

Grown bacteria (3 independent cultures / bacteria / growth condition) were harvested by centrifugation for 7 min at 1500 x g at +4 °C and washed twice with, and eventually resuspended in 0.15 M NaCl. The high electrolyte concentration was used to avoid charge interference (some nonpolar solvent droplets may become negatively charged in aqueous solutions and subsequently mask the cell surface charge). The turbidity of microbial suspensions at 600 nm was adjusted to  $0.25 \pm 0.01$  (giving a CFU of  $1-2 \times 10^8 / \text{mL}$ ) and a 1 mL sample was taken (Sample A<sub>0</sub>). A total of 2.4 mL of this microbial solution was then vortexed for 1 min with 0.4 mL of solvent, and the mixture was allowed to stand for 15 min to

completely separate the two phases. Another 1mL sample was carefully taken from the aqueous phase (sample A). The turbidity of both samples at 400 nm was then determined. The percentage of bacterial cells present in each solvent was subsequently calculated by using the following equation: % affinity = 100 x [1-(A/A<sub>0</sub>)].

The results are presented as mean (SEM) of % affinity of three independent experiments each performed in duplicate. To facilitate the evaluation of basic/acidic characteristics of lactobacilli, solvent pair ratios (i.e. chloroform / tetradecane and ethyl acetate / octane) were calculated, plotted and statistically assessed.

### **5.6 Bacterial viability assay**

In the Study IV, bacteria were grown anaerobically in different MRS broths supplemented with varying PUFA. After the incubation period, the final bacterial concentrations and bacterial viability were assessed using flow cytometric viability staining method based on bacterial membrane permeability (Virta et al. 1998).

The results are presented as mean of % viability (compared to control culture) assessed in three independent experiments each performed in singlicate.

### **5.7 Preparation and analysis of serum fatty acid samples**

Serum was separated from whole blood according to tube manufacturer's instructions and transferred to -20°C.

Serum fatty acid analyses were carried out using method described previously (Erkkilä et al. 1998, Ågren et al. 1992). Lipids were extracted from serum samples of 100 µL with chloroform-methanol (2:1), and separated with an aminopropyl column to three fractions, i.e. cholesteryl esters (CE), triglycerides (TG) and phospholipids (PL). Fatty acids were then transmethylated with 14% borontrifluoride in methanol at 100°C for 1 hr.

Fatty acid methyl esters were analyzed in singlicate using Hewlett-Packard 5890 series II - Gas Chromatography (Hewlett-Packard Company, Waldbronn, Germany) equipped with FFAP-column (length 25 m, Ø 2mm, and film thickness 0.3µm) helium as a carrier gas.

Peaks were identified by comparison of their retention times to the retention times of pure fatty acid methyl ester reference compounds using heptadecanoate acid as an internal standard to quantify the fatty acids. Quantitative results are presented as molar percentage of total fatty acids.

### **5.8 Preparation and analysis of plasma fatty acid samples**

The whole blood samples were centrifuged to separate the plasma, and the plasma were immediately stored at  $-70^{\circ}\text{C}$  for fatty acid analysis.

Lipids were extracted from 100  $\mu\text{L}$  plasma with 6 mL chloroform-methanol (2:1, v/v) using the procedure described by Folch and co-workers (Folch et al. 1957). Evaporated lipids were resuspended to 0.5 mL chloroform and fractionated on silica Sep-Pak columns (Waters Corp., USA) by eluting with 10 mL chloroform (neutral lipids; NL) followed by 20 mL methanol (phospholipids; PL). Both fractions were evaporated to dryness and transesterified by sodium methoxide catalysis (Christie 1982).

The fatty acid methyl esters of each sample were analyzed in duplicate using PerkinElmer AutoSystem Gas Chromatograph (PerkinElmer Corp., USA) equipped with programmed split/splitless injector, flame ionisation detector and silica gas chromatography column NB-351 (length 25 m,  $\varnothing$  0.32mm, and film thickness 0.2 $\mu\text{m}$ ). The Gas Chromatograph system was controlled with the Turbochrom Navigator 4 (PerkinElmer, San Jose, USA). Helium (1.7 mL / min) was used as a carrier gas.

Peaks were identified by comparison of their retention times to the retention times of standard mixture of known (68D, NuChek Prep, Elysian, USA). Quantitative results are expressed as relative peak area % (its proportion to the sum of all fatty acid peak areas).

### **5.9 Preparation and analysis of breast milk fatty acid samples**

To collect the breast milk samples, infants were allowed to suckle the nipple for few minutes, then a breast milk sample (10mL) was taken and the feeding continued. Samples were immediately transferred to the freezer at  $-70^{\circ}\text{C}$  until analyzed.

Lipids of breast milk samples were extracted using the standardized method of International Dairy Federation for milk fat determination (International Dairy Federation 1987), except that the reagent volumes were adjusted to match with the available sample volumes and only one dose of petroleum ether / diethyl ether was used. Fatty acids of milk lipids (20 mg / sample) were then methylated using sodium methoxide + methanol in hexane (Christie 1982) with minor modifications; the solvent was not evaporated but the excess of methanol in hexane layer was adsorbed on anhydrous CaCl<sub>2</sub> before gas chromatography analyses.

Samples of fatty acid methyl esters were analyzed in singlicate by HP 6890 Gas Chromatography (Hewlett-Packard GmbH, Waldbronn, Germany) equipped with electronic gas control, automatic sampler and injector, split-splitless inlet, FocusLiner™ (SGE International Pty Ltd, Ringwood, Australia). A silica capillary column coated (length 100m, Ø 0.2mm) with film thickness of 0.20 µm CP-Sil 88 cyano silicone phase (Chrompack International BV, Middelburg, The Netherlands) and a flame ionization detector. Instrument control and data processing were done using ChemStation A04.02 program on HP Vectra XM2 4/100i computer (Hewlett-Packard Co., Wilmington, USA).

Peaks were identified by comparison of their retention times to the retention times of pure fatty acid methyl ester reference compounds or known fatty acid methyl ester mixtures and by analyzing natural reference fats with literature data. Quantitative results were expressed as relative peak area % (its proportion of the sum of all fatty acid peak areas).

### **5.10 Preparation and analysis of bacterial whole cell fatty acid samples**

In the study III, bacteria were grown anaerobically in MRS broth supplemented with PUFA at 5 µg / mL or without PUFA supplementation. After cultivation, bacterial cells were harvested by centrifugation for 7 min at 1500 x g at 4 °C and washed twice with phosphate buffered saline (pH 7.4). Each bacterial culture tube (n=6 / bacteria / culture condition), containing approximately 100-500 mg wet cell biomass, were capped and stored at 4 °C prior to analysis.

Preparation and analysis of bacterial fatty acids methyl esters was carried according to the Anaer1 method of the Microbial Identification System (MIDI, Microbial ID, Newark, DE). In short, bacterial culture preparates were treated through saponification, methylation, extraction and washing phases prior to gas chromatographic analysis. For the gas chromatographic



analysis of bacterial extracts, the solvents were evaporated and the bacterial extracts resuspended to 0.5 mL hexane and analyzed in duplicate with the same gas chromatograph system described for plasma fatty acid analysis (see section 5.8).

Peaks were identified by comparing their retention times with those of a known standard mixture (68D, NuChek Prep, Elysian, USA), or by co-injection with reference compounds CLA60 standard (kindly provided by K. Nurmela, Valio Ltd., Finland) and 19:cy standard containing methyl esters of dihydrosterculic acid (cis-9,10-methyleneoctadecanoate) and lactobacillic acid (cis-11,12-methyleneoctadecanoate) purchased from Larodan Fine Chemicals AB, Malmö, Sweden). The fatty acid compositions are expressed as relative weight % (w/w) values.

### 5.11 Food records

Calculations of energy and fat intake were made with the Micro-Nutrica computer program (version 2.0, Research Centre of the Social Insurance Institution, Turku, Finland), which uses constantly updated Food and Nutrient Data Base of the Social Insurance Institution (Rasta et al. 1993). The total intake of SFA, MUFA, linoleic and  $\alpha$ -linolenic acid was calculated.

### 5.12 Statistical analysis

Normal distribution of variables was confirmed with Kolmorov-Smirnov test. Differences in fatty acid intake, and fatty acid composition of breast milks and serum lipid fatty acids were tested by multivariate analysis of variance with Fishers PLSD when comparing different groups. In pairwise comparisons *t*-tests with correction of Bonferroni were used, i.e. breast milk comparisons in relation to mothers' condition (atopic vs. non-atopic mothers) and serum fatty acid composition in relation to children's condition (atopic vs. non-atopic children). The level of significance was set to  $p < 0.05$ . The correlations between fatty acid intake and fatty acid composition of breast milks and composition of breast milks and serum lipid fatty acids were analyzed by linear regression and Spearman Rank correlation test. The significance level for correlations was set to  $p < 0.01$ . The results for continuous variables are expressed as means (95% CI).

In the Study II, the analyzed plasma lipid compositions following different study formulas were normally distributed. Statistical differences within groups (before vs. after treatment)

were tested with two-tailed paired *t* test with the level of significance  $p < 0.05$ . Statistical differences between groups were assessed in two consequent phases, ANOVA was used to show general difference between groups ( $p < 0.05$ ). And in the case of significant difference, multiple comparison procedure of Bonferroni *t* test (with the level of significance  $<0.0167$ ) was used to isolate the parameters responsible for the different results.

In the Study III, the changes in lipid composition and hydrophobicity associated with the different growth conditions were normally distributed. Statistical differences were tested with a two-tailed paired *t* test using a *P* value of less than 0.05 as cut-off for significance.

In the Study IV, a student's *t* test was used to determine significant differences ( $P < 0.05$ ) in bacterial growth and adhesion in the presence or absence of PUFA.

SPSS for Windows program (version 8.0, SPSS Inc., Chicago, USA) statistical program was used in the study I, whereas the statistical analyses of the following Studies II-IV were performed using StatView 4.57 (Abacus Concepts Inc. Berkeley, CA, USA) statistical program.

## 6 RESULTS

### 6.1 PUFA in maternal diet, breast milk and serum lipids of infants (I)

#### 6.1.1 Maternal diet

The mean (SD) energy intake of mothers was 8.3 (1.8) MJ of which protein intake comprised 15.7 % (2.3), fat 36.4 % (5.8) and carbohydrate 47.3 % (5.4). Total fat intake was further analyzed for proportions of SFA, MUFA and PUFA: 43.1 % (3.6), 34.3 % (3.2), and 15.1 % (2.3), respectively. The intake of linoleic acid and  $\alpha$ -linolenic acid varied considerably, but based on means the overall n-6 to n-3 ratio of 6.5 (1.8) was calculated.

No differences in the intake of energy or PUFA were observed in mothers. However, when the food records were analyzed according to children's atopic status, mothers having a healthy child consumed less fat in their diet compared to mothers whose child suffered from atopic dermatitis, 74.3 g / d (22.2) vs. 92.7 g / d (18.1),  $p = 0.04$ , and more linoleic acid (relative percentage; 12.8 % (2.2) vs. 10.6 % (1.8),  $p = 0.05$ ). The intake of n-3 PUFA from marine sources was generally very low, as only 8 / 28 mothers (5 allergic and 3 healthy mothers) consumed oily fish foods during the recording days. Of these eight children, two (children of allergic mothers) developed atopy by the age of 3 months.

#### 6.1.2 Maternal breast milk profile

The PUFA profiles of breast milks are shown in Table 8. Breast milk of healthy mothers contained more  $\gamma$ -linolenic acid (18:3 n-6) and less docosahexaenoic acid (22:6 n-3) than their allergic counterparts ( $p = 0.04$  and  $0.03$ , respectively [ $n=20$ ]). The ratio of n-6 to n-3 PUFA was therefore higher in healthy mothers; 4.49 (1.08) than in allergic mothers; 3.90 (0.62),  $p=0.04$ . When the breast milk composition was analyzed according to atopic status of the children ( $n=20$ ), the n-6 to n-3 ratio in breast milk from mothers of healthy children was lower 3.92 (0.52) compared to ratio seen in breast milk from mothers of atopic children 4.47 (1.14),  $p < 0.05$ . When groups were further subdivided ( $n=10$ ), healthy mothers with atopic children possessed a higher in n-6 to n-3 ratio in their breast milk than allergic mothers with atopic children; 5.08 (1.22) vs. 3.85 (0.66),  $p = 0.01$ .

### 6.1.3 Correlation between diet and breast milk fatty acids

A significant correlation was observed between the consumed SFA and the sum of SFA in breast milk of allergic mothers ( $r = 0.61$ ,  $p < 0.01$ ). No correlation between PUFA intake and proportions of individual PUFA in breast milk were observed in either group.

### 6.1.4 The influence of breast milk on serum fatty acid profiles in infants

Table 9 compares the fatty acid composition of serum CE, PL and TG of both infants with atopic dermatitis and healthy controls ( $n=20$  / group). Healthy infants had more  $\gamma$ -linoleic acid in PL fraction and less linoleic acid in TG fraction than the atopic group ( $p = 0.05$  and  $p = 0.03$ , respectively). Atopic infants had higher sum of n-6 fatty acids and subsequently higher n-6 to n-3 ratio in TG fraction ( $p = 0.02$  for both). In CE fraction, healthy infants possessed higher proportion of docosahexaenoic acid (22:6 n-3) and the sum of n-3 fatty acids ( $p = 0.03$  and  $p = 0.05$ , respectively). Subsequently, n-6 to n-3 fatty acid ratio was also lowered in healthy ( $p = 0.02$ ).

Several PUFA in breast milk correlated with subsequent serum lipid fatty acid proportions of non-atopic infants. In PL fraction, the proportions of eicosatrienoic acid (20:3  $\omega$ -6) ( $r = 0.65$ ,  $p < 0.01$ ) and arachidonic acid ( $r = 0.736$ ,  $p < 0.01$ ) positively correlated with corresponding proportions in breast milk. In CE fraction of serum lipids, there was a significant positive correlation in the proportions of milk  $\gamma$ -linolenic acid ( $r = 0.790$ ,  $p < 0.001$ ) and arachidonic acid ( $r = 0.731$ ,  $p < 0.01$ ) and in the TG fraction,  $\gamma$ -linolenic acid ( $r = 0.723$ ,  $p < 0.01$ ),  $\alpha$ -linolenic acid ( $r = 0.668$ ,  $p < 0.01$ ), and docosahexaenoic acid ( $r = 0.766$ ,  $p < 0.001$ ) positively correlated with breast milk proportions.

In atopic infants, no correlations were observed in PL fraction. However, eicosatrienoic acid ( $r = 0.856$ ,  $p < 0.001$ ) and sum of n-3 PUFA ( $r = 0.990$ ,  $p < 0.001$ ) in serum TG and sum of n-6 PUFA ( $r = 0.679$ ,  $p < 0.01$ ) in serum CE positively correlated with corresponding proportions of breast milk PUFA.

**TABLE 8.** PUFA composition in breast milk, presented as mean (SD), of allergic and healthy mothers in relation to atopic status of their children at the age of 3 months.

allergic / atopic status		BREAST MILK FATTY ACIDS									
Mother	Child	n	18:2 n-6	18:3 n-6	20:4 n-6	18:3 n-3	20:5 n-3	22:6 n-3	n-6 : n-3	Σ n-6	Σ n-3
	Atopic	20	9.56 (2.82)	0.08 (0.03)	0.33 (0.10)	1.67 (0.71)	0.09 (0.06)	0.27 (0.19)	4.47 (1.14)*	10.55 (2.95)	2.46 (0.77)
	Healthy	20	9.00 (1.42)	0.07 (0.03)	0.30 (0.06)	1.74 (0.51)	0.09 (0.04)	0.30 (0.10)	3.92 (0.52)	9.92 (1.52)	2.58 (0.56)
Allergic	Healthy	20	8.92 (1.84)	0.06 (0.03)*	0.30 (0.08)	1.63 (0.60)	0.10 (0.06)	0.33 (0.19)*	3.90 (0.62)*	9.81 (1.96)	2.59 (0.67)
	Atopic	20	9.64 (2.54)	0.08 (0.03)	0.32 (0.09)	1.78 (0.63)	0.08 (0.03)	0.23 (0.09)	4.49 (1.08)	10.66 (2.65)	2.46 (0.68)
Healthy	Atopic	10	10.22(3.21)	0.08 (0.04)	0.36 (0.11)	1.68 (0.68)	0.07 (0.03)	0.19 (0.04)	5.08 (1.22) <sup>#</sup>	11.33 (3.31)	2.31 (0.73)
	Healthy	10	9.06 (1.62)	0.08 (0.02)	0.29 (0.04)	1.88 (0.59)	0.10 (0.03)	0.28 (0.10)	3.89 (0.43)	9.99 (1.69)	2.61 (0.62)
Allergic	Atopic	10	8.90 (2.36)	0.07 (0.03)	0.30 (0.09)	1.66 (0.77)	0.12 (0.08)	0.34 (0.25)	3.85 (0.66)	9.77 (2.48)	2.61 (0.82)
	Healthy	10	8.93 (1.26)	0.06 (0.03)	0.31 (0.08)	1.60 (0.39)	0.08 (0.04)	0.31 (0.10)	3.93 (0.62)	9.84 (1.41)	2.56 (0.52)

\* statistically significant difference ( $P < 0.05$ ) between atopic and healthy children, and between allergic and healthy mother (unpaired  $t$ -test)

<sup>#</sup> statistically significant difference between healthy mothers with atopic children and allergic mothers with atopic children, (MANOVA,  $P < 0.05$ ) Bonferroni  $t$ -test  $P = 0.01$

**TABLE 9.** Serum lipid PUFA composition, presented as mean (SD), in atopic and healthy children at the age of 3 months.

PUFA	TG		CE		PL	
	Atopic child (n = 20)	Healthy child (n = 20)	Atopic child (n = 20)	Healthy child (n = 20)	Atopic child (n = 20)	Healthy child (n = 20)
18:2 n-6	14.22 (2.89)*	12.57 (1.99)	46.21 (4.38)	45.20 (4.85)	21.28 (2.89)	21.28 (2.95)
18:3 n-6	0.21 (0.06)	0.18 (0.05)	0.47 (0.22)	0.40 (0.12)	0.12 (0.06)*	0.16 (0.03)
20:3 n-6	0.21 (0.06)	0.23 (0.07)	0.50 (0.13)	0.50 (0.12)	2.80 (0.60)	2.80 (0.59)
20:4 n-6	0.98 (0.34)	0.81 (0.44)	5.62 (1.78)	5.31 (1.41)	8.22 (1.73)	7.74 (1.68)
22:4 n-6	nd**	nd	nd	nd	0.20 (0.05)	0.19 (0.04)
18:3 n-3	1.19 (0.61)	1.46 (0.34)	0.51 (0.17)	0.57 (0.11)	0.22 (0.07)	0.22 (0.04)
20:5 n-3	0.23 (0.12)	0.22 (0.13)	0.44 (0.22)	0.51 (0.19)	0.58 (0.24)	0.53 (0.19)
22:5 n-3	0.21 (0.10)	0.17 (0.07)	nd	nd	0.58 (0.15)	0.62 (0.15)
22:6 n-3	0.46 (0.30)	0.51 (0.35)	0.41 (0.19)*	0.54 (0.22)	3.43 (0.92)	3.74 (0.98)
n-6 : n-3	7.32 (4.91)*	5.83 (2.01)	38.47 (9.56)*	31.73 (9.49)	6.82 (2.99)	6.30 (2.60)
Σ n-6	15.52 (2.86)*	13.77 (2.01)	52.70 (4.30)	51.41 (4.17)	32.61 (1.87)	32.17 (1.57)
Σ n-3	2.13 (0.79)	2.57 (0.59)	1.37 (0.47)*	1.62 (0.40)	4.78 (1.24)	5.12 (1.20)

\* statistically significant difference between atopic and non-atopic children,  $P < 0.05$  (unpaired  $t$ -test)

\*\* not detected

## 6.2 Effects of probiotics on plasma lipid profiles of infants (II)

### 6.2.1 Inter-group differences

In general, the neutral lipids proportions of all three groups resembled each other (Table 10). Of individual fatty acids, only eicosapentaenoic acid (20:5 n-3) proportions were higher in both probiotic-supplemented groups compared to regular formula ( $p < 0.012$  for both). This difference was retained in *Bifidobacterium* Bb-12 supplemented formula group ( $p < 0.013$ ) over the study period, whilst regular formula and *Lactobacillus* GG supplemented formula group were similar in terms of eicosapentaenoic acid proportions at the end of the study. In addition, the proportion of MUFA was also lower in the *Bifidobacterium* Bb-12 supplemented formula group compared to group consuming regular formula ( $p = 0.002$ ) at the end of the study.

In PL (Table 11) there were some notable differences in baseline proportions between the study groups. At the beginning of the study, the proportions of MUFA ( $p < 0.004$ ) and linoleic acid (18:2 n-6;  $p < 0.014$ ) were lower in both probiotic-supplemented groups compared to regular formula group, and the difference remained statistically significant throughout the study ( $p < 0.002$ ). At the baseline, *Lactobacillus* GG supplemented formula group also possessed higher  $\alpha$ -linolenic acid (18:3 n-3) and docosahexaenoic acid (22:6 n-6) proportions compared to two other groups ( $p < 0.008$ ), but these differences diminished during the study period. Moreover, the baseline proportions of arachidonic acid (20:4 n-6) and eicosapentaenoic acid (20:5 n-3) were higher in the *Lactobacillus* GG supplemented formula group compared to *Bifidobacterium* Bb-12 supplemented formula group and regular formula group ( $p = 0.007$  and  $p = 0.015$ , respectively). After the study period, eicosapentaenoic acid (20:5 n-3) proportion in the *Bifidobacterium* Bb-12 supplemented formula group was higher when compared to regular formula group. ( $p = 0.007$ )

### 6.2.2 Infants' plasma lipid profile

The extensively hydrolyzed infant formula (regular formula) did influence to the proportions of various fatty acids in both analyzed fractions of plasma. In the neutral lipids (Table 10), the relative percentage of both total SFA and arachidonic acid (20:4 n-6) decreased ( $p = 0.003$  and  $p = 0.001$ , respectively), and that of MUFA increased ( $p = 0.001$ ) during the study period.

In the PL (Table 11), the proportions of the total MUFA and linoleic acid (18:2 n-6) increased ( $p < 0.001$  and  $p < 0.05$ , respectively), and the proportions of arachidonic acid, total n-3 PUFA and docosahexaenoic acid (22:6 n-3) decreased ( $p = 0.003$ ,  $p = 0.003$  and  $p = 0.001$ , respectively).

### 6.2.3 Effect of *Lactobacillus* GG on infants' plasma lipid profile

As with the regular formula, the *Lactobacillus* GG supplemented formula increased the relative percentage of the total MUFA ( $p = 0.001$ ) and decreased arachidonic acid ( $p = 0.002$ ) in plasma neutral lipids (Table 10). Additionally, the total n-3 PUFA and  $\alpha$ -linolenic acid (18:3 n-3) decreased in those infants receiving the *Lactobacillus* GG supplemented formula ( $p = 0.002$  and  $p < 0.05$ , respectively), consequently increasing the n-6 to n-3 ratio ( $p = 0.02$ ).

Similar to the regular formula in PL, the *Lactobacillus* GG supplemented formula increased the proportions of total MUFA and linoleic acid ( $p < 0.001$  and  $p = 0.03$ , respectively), whereas the proportions of arachidonic acid, total n-3 PUFA and docosahexaenoic acid decreased ( $p < 0.001$  for each) (Table 11). Additionally, the *Lactobacillus* GG supplemented formula decreased the proportion of eicosapentaenoic acid (20:5 n-3) in PL ( $p = 0.001$ ). These alterations resulted in a more than 2-fold increase in n-6 to n-3 PUFA ratio ( $p < 0.001$ ).

### 6.2.4 Effect of *Bifidobacterium* Bb-12 on infants' plasma lipid profile

In neutral lipids, the extensively hydrolyzed infant formula supplemented with *Bifidobacterium* Bb-12 mimicked the effects of the regular formula (Table 10); the relative percentage of the total SFA and arachidonic acid decreased ( $p = 0.01$  and  $p = 0.002$ , respectively), and that of MUFA increased ( $p = 0.02$ ). In addition to these background changes, the proportion of  $\alpha$ -linolenic acid in neutral lipids decreased with the *Bifidobacterium* Bb-12 supplemented formula ( $p = 0.03$ ).

In PL (Table 11), the *Bifidobacterium* Bb-12 supplemented formula increased the proportions of total MUFA ( $p = 0.001$ ), linoleic acid ( $p < 0.05$ ) and  $\alpha$ -linolenic acid ( $p = 0.002$ ), and decreased arachidonic acid ( $p = 0.03$ ) and docosahexaenoic acid ( $p = 0.04$ ).



**TABLE 10.** Effects of different infant formulas on fatty acid composition of serum neutral lipids in atopic infants (mean  $\pm$  SEM). The change % -columns in the table represent the % FA at the study completion compared to baseline.

	Infant formula											
	<i>Lactobacillus</i> GG				<i>Bifidobacterium</i> Bb12				regular formula			
	before	after	change %	before	after	change %	before	after	change %	before	after	change %
$\Sigma$ SFA	26.27 $\pm$ 1.26	25.10 $\pm$ 2.22	96	26.01 $\pm$ 0.92	22.21 $\pm$ 1.26	85*	27.19 $\pm$ 0.44	22.99 $\pm$ 0.79	85*			85*
$\Sigma$ MUFA	32.12 $\pm$ 0.99	36.85 $\pm$ 0.51	115**	29.68 $\pm$ 1.25	34.43 $\pm$ 0.99	116**	31.82 $\pm$ 0.95	38.20 $\pm$ 0.70	120**			120**
$\Sigma$ n-6	28.45 $\pm$ 1.51	29.12 $\pm$ 0.60	102	31.46 $\pm$ 1.78	29.31 $\pm$ 1.86	93	28.90 $\pm$ 1.40	28.39 $\pm$ 1.30	98			98
18:2 n-6	25.60 $\pm$ 1.36	27.73 $\pm$ 0.58	108	29.07 $\pm$ 1.88	27.76 $\pm$ 1.74	95	26.54 $\pm$ 1.36	27.14 $\pm$ 1.25	102			102
20:4 n-6	2.84 $\pm$ 0.25	1.39 $\pm$ 0.13	49**	2.39 $\pm$ 0.13	1.55 $\pm$ 0.13	65**	2.36 $\pm$ 0.24	1.26 $\pm$ 0.07	53**			53**
$\Sigma$ n-3	1.30 $\pm$ 0.08	0.80 $\pm$ 0.06	62**	1.23 $\pm$ 0.08	1.11 $\pm$ 0.17	90	0.83 $\pm$ 0.08	1.09 $\pm$ 0.24	131			131
18:3 n-3	1.04 $\pm$ 0.10	0.76 $\pm$ 0.05	73*	0.94 $\pm$ 0.07	0.72 $\pm$ 0.10	77*	0.76 $\pm$ 0.08	1.04 $\pm$ 0.23	137			137
20:5 n-3	0.27 $\pm$ 0.06	0.15 $\pm$ 0.03	56	0.29 $\pm$ 0.06	0.39 $\pm$ 0.15	134	0.12 $\pm$ 0.01	0.12 $\pm$ 0.02	100			100
n-6 : n-3	22.41 $\pm$ 1.59	39.19 $\pm$ 4.48	175*	27.20 $\pm$ 2.99	36.53 $\pm$ 8.69	134	39.38 $\pm$ 5.28	35.05 $\pm$ 5.79	89			89

\* significant difference in fatty acid proportion before and after supplementation within each group;  $P < 0.05$

\*\* significant difference in fatty acid proportion before and after supplementation within each group;  $P < 0.01$

**TABLE 11.** Effects of different infant formulas on fatty acid composition of serum PL in atopic infants (mean  $\pm$  SEM). The change % -columns in the table represent the % FA at the study completion compared to baseline.

	Infant formula											
	<i>Lactobacillus</i> GG					<i>Bifidobacterium</i> Bb12						
	before	after	change %	before	after	change %	before	after	change %	before	after	change %
$\Sigma$ SFA	43.98 $\pm$ 0.56	46.26 $\pm$ 0.95	105	42.94 $\pm$ 0.68	42.35 $\pm$ 1.23	99	45.67 $\pm$ 0.53	45.65 $\pm$ 0.24	100			
$\Sigma$ MUFA	10.36 $\pm$ 0.27	14.01 $\pm$ 0.24	135***	9.61 $\pm$ 0.31	12.68 $\pm$ 0.59	132**	11.67 $\pm$ 0.36	15.06 $\pm$ 0.29	129***			
$\Sigma$ n-6	31.98 $\pm$ 0.55	31.01 $\pm$ 0.76	97	29.09 $\pm$ 1.02	30.76 $\pm$ 0.64	106	32.98 $\pm$ 0.78	32.42 $\pm$ 0.22	98			
18:2 n-6	21.10 $\pm$ 0.69	24.29 $\pm$ 0.55	115*	20.31 $\pm$ 0.84	24.03 $\pm$ 0.39	118*	23.31 $\pm$ 1.08	25.97 $\pm$ 0.17	111*			
20:4 n-6	10.88 $\pm$ 0.32	6.72 $\pm$ 0.51	62***	8.77 $\pm$ 0.74	6.74 $\pm$ 0.44	77*	9.67 $\pm$ 0.64	6.46 $\pm$ 0.18	67**			
$\Sigma$ n-3	5.59 $\pm$ 0.35	2.54 $\pm$ 0.29	45***	3.55 $\pm$ 0.47	2.23 $\pm$ 0.23	63	3.28 $\pm$ 0.35	1.80 $\pm$ 0.13	55**			
18:3 n-3	0.18 $\pm$ 0.01	0.19 $\pm$ 0.02	106	0.13 $\pm$ 0.03	0.24 $\pm$ 0.03	185**	0.12 $\pm$ 0.01	0.21 $\pm$ 0.06	175			
20:5 n-3	0.59 $\pm$ 0.09	0.13 $\pm$ 0.04	22***	0.46 $\pm$ 0.13	0.28 $\pm$ 0.07	61	0.22 $\pm$ 0.05	0.10 $\pm$ 0.04	45			
22:6 n-3	4.81 $\pm$ 0.27	2.22 $\pm$ 0.25	46***	2.95 $\pm$ 0.37	1.71 $\pm$ 0.16	58*	2.94 $\pm$ 0.30	1.49 $\pm$ 0.13	51**			
n-6 / n-3	6.00 $\pm$ 0.50	13.58 $\pm$ 1.37	226***	11.42 $\pm$ 2.89	12.43 $\pm$ 1.86	109	12.44 $\pm$ 2.59	19.13 $\pm$ 1.77	154			

\* significant difference in fatty acid proportion before and after supplementation within each group;  $P < 0.05$

\*\* significant difference in fatty acid proportion before and after supplementation within each group;  $P < 0.01$

\*\*\* significant difference in fatty acid proportion before and after supplementation within each group;  $P < 0.001$

### 6.3 Effects of PUFA on physicochemical properties of probiotics (III)

#### 6.3.1 Bacterial cell fatty acid composition

The methodology used in the study was able to resolve oleic and vaccenic acid methyl esters better than 95%. Pure dihydrosterculic and lactobacillic acid methyl esters were also resolved. However, when sample contained  $\alpha$ -linolenic acid, the peaks of dihydrosterculic acid and  $\alpha$ -linolenic acid did partially overlap (the principal component was identified as dihydrosterculic acid according to co-injection with reference compound). In such a case, the peak of lactobacillic acid appeared as a shoulder of the  $\alpha$ -linolenic acid peak (see Figure 6). Two conjugated linoleic acid (CLA) peaks observed were also recognized to be a mixture of two isomers, namely c-9,t-11 (the major isomer) and t-8, c-10 whereas the latter was a mixture of t-10,c-12 (the major isomer) and c-11,t-13 isomers. Moreover, the chromatographic method used in the present study could not separate the peaks of docosahexaenoic acid and 24:1, therefore the results dealing with docosahexaenoic acid are inconclusive.

As shown in Tables 12-14, all three lactobacilli strains grown without any PUFA supplementation possessed various PUFA. Above all, CLA isomers,  $\gamma$ -linolenic, eicosapentaenoic, docosahexaenoic and  $\alpha$ -linolenic acids were present, whilst linoleic and arachidonic acids were absent in three lactobacilli tested. The most abundant bacterial fatty acids identified were oleic, vaccenic and dihydrosterculic acid.

Culturing of *Lactobacillus* GG (Table 12) with linoleic acid increased the proportion of vaccenic acid ( $p = 0.04$ ), but decreased the proportions of dihydrosterculic acid /  $\alpha$ -linolenic acid ( $p < 0.001$ ), docosahexaenoic acid + 24:1 peaks ( $p = 0.03$ ). A negative trend can be in the proportions of both CLA isomers ( $p < 0.07$ ).  $\gamma$ -linolenic acid have nearly identical effects as linoleic acid on *Lactobacillus* GG fatty acids; decrease in dihydrosterculic acid /  $\alpha$ -linolenic acid ( $p = 0.02$ ), docosahexaenoic acid + 24:1 ( $p < 0.07$ ) and both CLA isomers ( $p = 0.04$  and  $p = 0.05$ , respectively) was observed. Arachidonic acid in the medium led to contradictory changes (compared to above) in fatty acid proportions of *Lactobacillus* GG. Both dihydrosterculic acid /  $\alpha$ -linolenic acid ( $p = 0.02$ ) and t-10,c-12 CLA isomer ( $p < 0.07$ ) were increased, while eicosapentaenoic acid appeared to be decreased ( $p = 0.04$ ).  $\alpha$ -linolenic acid in the medium only tended to decrease SFA proportions ( $p < 0.07$ ); no other alterations were demonstrated. Docosahexaenoic acid increased the bacterial cell fatty acid proportions of

oleic acid ( $p = 0.04$ ), dihydrosterculic acid /  $\alpha$ -linolenic acid ( $p = 0.01$ ) and both CLA isomers ( $p < 0.07$  for both). Paradoxically though, docosahexaenoic acid supplementation slightly decreased its own levels ( $p < 0.07$ ) in the fatty acids of *Lactobacillus* GG.

The incorporation of various free PUFA into bacterial fatty acids was also observed with *L. bulgaricus* (Table 13) and *L. casei* Shirota (Table 14). Linoleic acid and  $\gamma$ -linolenic acid in the growth medium of *L. bulgaricus* increased the proportions of vaccenic acid ( $p = 0.03$ ) and oleic acid ( $p = 0.05$ ), respectively. The proportions of both CLA isomers were increased by  $\alpha$ -linolenic and docosahexaenoic acids ( $p = 0.05$  for all), the same tendency seen in *Lactobacillus* GG fatty acids.  $\alpha$ -linolenic acid also increased the proportions of vaccenic acid ( $p < 0.001$ ) and dihydrosterculic acid /  $\alpha$ -linolenic acid ( $p = 0.03$ ). Most probably this alteration is due to increase in  $\alpha$ -linolenic acid. In the case of *L. casei* Shirota (Table 14), linoleic and  $\gamma$ -linolenic acids decreased the proportions of oleic acid ( $p < 0.001$  and  $p = 0.01$ , respectively) and vaccenic acid ( $p < 0.001$  for both) and increased eicosapentaenoic acid ( $p = 0.05$  for both). In addition,  $\gamma$ -linolenic acid decreased the proportion of dihydrosterculic acid /  $\alpha$ -linolenic acid ( $p = 0.02$ ) and tended to increase t-10,c-12 CLA isomer ( $p < 0.07$ ). Of the n-3 PUFA, docosahexaenoic acid had no effects, whilst  $\alpha$ -linolenic acid decreased the proportion of vaccenic acid ( $p = 0.01$ ) and both CLA isomers ( $p = 0.03$  for both).

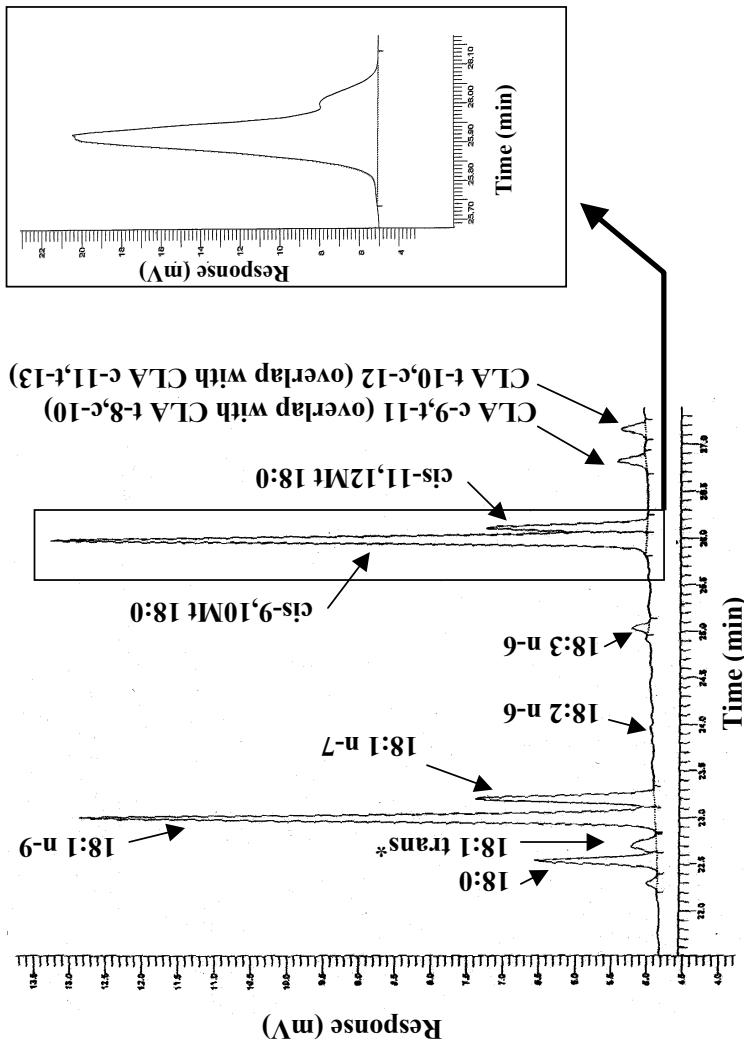

**FIGURE 6.** Enlarged chromatogram of the region 18:0, 18:1, and CLA isomers. The chromatogram represents the cellular fatty acids of *Lactobacillus* GG cultured in normal, non-PUFA supplemented MRS broth. The cyclopropenic acid region of another chromatogram *Lactobacillus* GG cultured in  $\alpha$ -linolenic acid supplemented MRS broth is shown in the framed appendix. \* identification of the peak not based on standard

**TABLE 12.** Effect of various free PUFA in the growth medium (PUFA at 5 µg / mL) on the fatty acid composition of total lipids of *Lactobacillus* GG. Values are means (% wt) ± SEM of six independently prepared fatty acid methyl esters analyzed in duplicate. Significant difference \*  $P < 0.05$ , trend \*\*  $P < 0.07$ .

Identified fatty acid	<i>Lactobacillus</i> GG grown in MRS supplemented with						
	(control)	18:2 n-6	18:3 n-6	20:4 n-6	18:3 n-3	22:6 n-3	
Σ SAFA <sup>1</sup>	21.5 ± 3.8	31.8 ± 0.6	31.1 ± 0.9	15.8 ± 0.1	11.9 ± 0.1**	15.4 ± 0.1	
18:1 n-9	21.8 ± 2.5	19.1 ± 1.5	20.6 ± 0.1	27.3 ± 0.2	28.0 ± 0.1	29.2 ± 0.3*	
18:1 n-7	4.3 ± 0.7	6.2 ± 0.4*	5.6 ± 0.5	3.5 ± 0.1	3.2 ± 0.1	3.4 ± 0.0	
18:2 n-6	nd <sup>2</sup>	3.6 ± 0.5*	nd <sup>2</sup>	nd <sup>2</sup>	nd <sup>2</sup>	nd <sup>2</sup>	
18:3 n-6	0.3 ± 0.1	0.5 ± 0.1	2.1 ± 0.4*	0.5 ± 0.1	0.3 ± 0.1	0.5 ± 0.1	
20:4 n-6	nd <sup>2</sup>	nd <sup>2</sup>	nd <sup>2</sup>	0.5 ± 0.0*	nd <sup>2</sup>	nd <sup>2</sup>	
cis-9,10Mt 18:0 / 18:3 n-3 <sup>3</sup>	23.5 ± 1.7	15.8 ± 0.6*	18.1 ± 0.8*	31.5 ± 0.6*	27.7 ± 0.3	30.2 ± 0.4*	
cis-11,12Mt 18:0	2.1 ± 1.2	3.7 ± 0.1	2.9 ± 0.6	nd <sup>2</sup>	3.1 ± 0.0	nd <sup>2</sup>	
20:5 n-3	1.0 ± 0.1	1.2 ± 0.1	1.4 ± 0.3	0.9 ± 0.0*	0.9 ± 0.0	0.9 ± 0.1	
22:6 n-3 + 24:1 <sup>3</sup>	1.7 ± 0.2	1.1 ± 0.1*	1.1 ± 0.1**	1.6 ± 0.2	1.8 ± 0.1	1.1 ± 0.1**	
18:2 c-9,t-11 / t-8,c-10 <sup>3</sup>	1.5 ± 0.2	0.8 ± 0.0**	0.9 ± 0.1*	1.9 ± 0.0	1.9 ± 0.1	2.0 ± 0.0**	
18:2 t-10,c-12 / c-11,t-13 <sup>3</sup>	1.4 ± 0.2	0.8 ± 0.0**	0.9 ± 0.1*	1.9 ± 0.0**	1.9 ± 0.0	2.1 ± 0.0**	

<sup>1</sup> Σ SAFA; 14:0 + 16:0 + 18:0 + 20:0 + 22:0

<sup>2</sup> nd; not detected

<sup>3</sup> overlapping peaks in the chromatograms

**TABLE 13.** Effect of various free PUFA in the growth medium (PUFA at 5 µg / mL) on the fatty acid composition of total lipids of *L. bulgaricus*. Values are means (% wt) ± SEM of six independently prepared fatty acid methyl esters analyzed in duplicate. Significant difference \*  $P < 0.05$ , trend \*\*  $P < 0.07$ .

Identified fatty acid	<i>L. bulgaricus</i> grown in MRS supplemented with					
	(control)	18:2 n-6	18:3 n-6	20:4 n-6	18:3 n-3	22:6 n-3
Σ SAFA <sup>1</sup>	13.8 ± 1.4	13.3 ± 0.6	14.2 ± 1.2	13.6 ± 0.7	13.9 ± 0.2	17.0 ± 0.2*
18:1 n-9	29.0 ± 3.9	34.3 ± 1.7	39.2 ± 2.4*	37.0 ± 1.9	27.5 ± 0.5	29.7 ± 0.5
18:1 n-7	3.5 ± 0.1	3.3 ± 0.1*	3.1 ± 0.2	3.4 ± 0.0	2.8 ± 0.0*	3.4 ± 0.0
18:2 n-6	nd <sup>2</sup>	3.5 ± 0.8*	nd <sup>2</sup>	nd <sup>2</sup>	nd <sup>2</sup>	nd <sup>2</sup>
18:3 n-6	0.5 ± 0.2	0.8 ± 0.4	2.1 ± 0.6*	0.4 ± 0.1	0.6 ± 0.2	0.5 ± 0.1
20:4 n-6	nd <sup>2</sup>	nd <sup>2</sup>	nd <sup>2</sup>	0.4 ± 0.0*	nd <sup>2</sup>	nd <sup>2</sup>
cis-9,10Mt 18:0 / 18:3 n-3 <sup>3</sup>	30.3 ± 0.2	27.7 ± 0.3	21.6 ± 3.5	26.6 ± 1.5	35.6 ± 0.7*	29.2 ± 0.7
cis-11,12Mt 18:0	nd <sup>2</sup>	nd <sup>2</sup>	nd <sup>2</sup>	nd <sup>2</sup>	nd <sup>2</sup>	nd <sup>2</sup>
20:5 n-3	1.4 ± 0.6	1.0 ± 0.1	1.1 ± 0.3	1.0 ± 0.1	0.7 ± 0.1	0.7 ± 0.1
22:6 n-3 + 24:1 <sup>3</sup>	1.7 ± 0.3	1.3 ± 0.4	1.1 ± 0.3	1.2 ± 0.4	1.9 ± 0.3	1.7 ± 0.3
18:2 c-9,t-11 / t-8,c-10 <sup>3</sup>	1.4 ± 0.2	1.1 ± 0.0	0.9 ± 0.2	1.1 ± 0.0	2.0 ± 0.0*	1.9 ± 0.0*
18:2 t-10,c-12 / c-11,t-13 <sup>3</sup>	1.3 ± 0.3	1.1 ± 0.0	0.8 ± 0.2	1.1 ± 0.1	1.9 ± 0.0**	1.9 ± 0.0*

<sup>1</sup> Σ SAFA; 14:0 + 16:0 + 18:0 + 20:0 + 22:0

<sup>2</sup> nd; not detected

<sup>3</sup> overlapping peaks in the chromatograms

**TABLE 14.** Effect of various free PUFA in the growth medium (PUFA at 5 µg / mL) on the fatty acid composition of total lipids of *L. casei* Shirota. Values are means (% wt) ± SEM of six independently prepared fatty acid methyl esters analyzed in duplicate. Significant difference \*  $P < 0.05$ , trend \*\*  $P < 0.07$ .

Identified fatty acid	<i>L. casei</i> Shirota grown in MRS supplemented with						
	(control)	18:2 n-6	18:3 n-6	20:4 n-6	18:3 n-3	22:6 n-3	
Σ SAFA <sup>1</sup>	13.5 ± 1.3	13.4 ± 0.4	13.9 ± 0.6	11.9 ± 1.0	11.0 ± 0.6	12.1 ± 1.0	
18:1 n-9	32.4 ± 1.1	25.1 ± 0.9*	28.6 ± 0.2*	31.7 ± 1.3	30.5 ± 0.8	33.3 ± 0.8	
18:1 n-7	3.1 ± 0.0	2.8 ± 0.0*	2.8 ± 0.0*	3.1 ± 0.0	2.9 ± 0.0*	3.1 ± 0.0	
18:2 n-6	nd <sup>2</sup>	4.6 ± 0.2*	nd <sup>2</sup>	nd <sup>2</sup>	nd <sup>2</sup>	nd <sup>2</sup>	
18:3 n-6	0.4 ± 0.1	0.5 ± 0.0	3.1 ± 0.5*	0.4 ± 0.1	0.6 ± 0.3	0.4 ± 0.1	
20:4 n-6	nd <sup>2</sup>	nd <sup>2</sup>	nd <sup>2</sup>	0.5 ± 0.0*	nd <sup>2</sup>	nd <sup>2</sup>	
cis-9,10Mt 18:0 / 18:3 n-3 <sup>3</sup>	35.3 ± 1.0	31.6 ± 1.8	31.1 ± 1.1*	37.5 ± 0.2	40.3 ± 0.4*	36.2 ± 0.4	
cis-11,12Mt 18:0	nd <sup>2</sup>	nd <sup>2</sup>	nd <sup>2</sup>	nd <sup>2</sup>	nd <sup>2</sup>	nd <sup>2</sup>	
20:5 n-3	0.8 ± 0.0	0.9 ± 0.0*	0.9 ± 0.0*	0.8 ± 0.0	0.8 ± 0.0	0.8 ± 0.0	
22:6 n-3 + 24:1 <sup>3</sup>	1.4 ± 0.1	1.9 ± 0.4	1.8 ± 0.2	1.1 ± 0.1	1.2 ± 0.1	1.0 ± 0.2	
18:2 c-9,t-11 / t-8,c-10 <sup>3</sup>	1.7 ± 0.1	1.9 ± 0.1	1.9 ± 0.1	1.6 ± 0.0	1.5 ± 0.0*	1.6 ± 0.0	
18:2 t-10,c-12 / c-11,t-13 <sup>3</sup>	1.7 ± 0.1	1.9 ± 0.1	2.0 ± 0.1**	1.5 ± 0.0	1.4 ± 0.0*	1.5 ± 0.0	

<sup>1</sup> Σ SAFA; 14:0 + 16:0 + 18:0 + 20:0 + 22:0

<sup>2</sup> nd; not detected

<sup>3</sup> overlapping peaks in the chromatograms



### 6.3.2 Physical properties of bacteria

The affinities with the four solvents used in the MATS method (Briandet et al 1999) of the *Lactobacillus* GG, *L. bulgaricus* and *L. casei* Shirota cells grown in MRS or in MRS supplemented with free PUFA are shown in Table 15.

Overall, the affinity of all three tested bacterial strains was low for all solvents tested. The low affinities of all lactobacilli to nonpolar solvents (both tetradecane and octane) indicate that these bacteria exhibited a hydrophilic rather than hydrophobic surface. When cultured with free PUFA, this modest hydrophobicity further diminished, the phenomenon especially seen with *L. casei* Shirota; all tested n-6 PUFA at lower concentration reduced % affinity to octane ( $p < 0.05$ ). As yet, the decrease in affinity to the nonpolar solvents was less marked in *Lactobacillus* GG and *L. bulgaricus* suggesting that the supplemented free PUFA altered hydrophobicity of these two strains less than of *L. casei* Shirota.

Because chloroform and tetradecane possess the same van der Waals properties, their adhesion values were expressed by calculating chloroform-to-tetradecane ratios. Only *Lactobacillus* GG (control culture) showed some electron-donating nature (adhered more to the acidic chloroform than to tetradecane, ratio 1.8) whereas no difference in the adhesion of *L. casei* Shirota and *L. bulgaricus* to chloroform and tetradecane was observed (chloroform / tetradecane ratios of 0.9 and 1.0, respectively). These values were set as a base line and changes in basic characteristics were evaluated (Figure 7A). All significant effects observed were related to the reduced basic surface properties. Namely, low concentration of linoleic acid and docosahexaenoic acids reduced the electron-donating nature of *Lactobacillus* GG ( $p < 0.05$ ). Likewise, 20  $\mu\text{g} / \text{mL}$  of linoleic acid, 5  $\mu\text{g} / \text{mL}$  of  $\gamma$ -linolenic and  $\alpha$ -linolenic acids reduced the electron-donating nature of *L. casei* Shirota ( $p = 0.02$ ,  $p = 0.03$ , and  $p = 0.03$ , respectively).

**TABLE 15.** Effect of various free PUFA in growth medium on bacterial cell surface properties of *Lactobacillus rhamnosus* GG, *Lactobacillus casei* Shirota and *Lactobacillus bulgaricus*. The two non-polar solvents (B and D) were used to estimate the hydrophobicity properties of the lactobacilli, whereas the two polar solvents (A and C) were selected for the estimation of the Lewis acid/base (i.e. electron donor/acceptor) character.

Bacterial strain / PUFA supplementation	PUFA μg/mL	% affinity (mean ± SEM)			
		A chloroform	B tetradecane	C ethyl acetate	D octane
<i>Lactobacillus</i> GG					
Control	0	15 ± 1	8 ± 0	3 ± 1	17 ± 3
18:2 n-6	5	10 ± 4	13 ± 3	2 ± 3	12 ± 2
	20	12 ± 1	13 ± 4	0 ± 1	11 ± 3
18:3 n-6	5	10 ± 2	10 ± 2	1 ± 1	10 ± 0
	20	9 ± 6	7 ± 1	1 ± 2	8 ± 2*
20:4 n-6	5	4 ± 1	8 ± 2	0 ± 1	11 ± 2
	20	8 ± 4	5 ± 1	1 ± 2	12 ± 2
18:3 n-3	5	9 ± 2	10 ± 4	2 ± 1	10 ± 3
	20	5 ± 2	15 ± 2	4 ± 2	14 ± 1
22:6 n-6	5	6 ± 1*	7 ± 1	1 ± 3	13 ± 3
	20	7 ± 8	16 ± 6	0 ± 3	12 ± 4
<i>L. bulgaricus</i>					
Control	0	13 ± 3	14 ± 2	3 ± 2	15 ± 2
18:2 n-6	5	9 ± 3	20 ± 6	1 ± 1	15 ± 4
	20	15 ± 5	17 ± 1	2 ± 1	11 ± 2
18:3 n-6	5	9 ± 2	22 ± 12	2 ± 1	12 ± 3
	20	10 ± 2	11 ± 2	1 ± 1	12 ± 4
20:4 n-6	5	8 ± 3	19 ± 10	0 ± 0	15 ± 1
	20	7 ± 0	10 ± 0	0 ± 0	8 ± 2
18:3 n-3	5	11 ± 3	25 ± 14	2 ± 2	14 ± 1
	20	13 ± 4	10 ± 2	2 ± 2	22 ± 4
22:6 n-6	5	8 ± 2	9 ± 3	1 ± 1	15 ± 2
	20	9 ± 2	10 ± 3	1 ± 1	24 ± 8
<i>L. casei</i> Shirota					
Control	0	11 ± 1	12 ± 0	2 ± 2	15 ± 1
18:2 n-6	5	7 ± 0*	14 ± 2	1 ± 1	11 ± 0*
	20	6 ± 2	16 ± 2	2 ± 0	14 ± 3
18:3 n-6	5	5 ± 0*	9 ± 2	0 ± 1	10 ± 1*
	20	11 ± 1	12 ± 1	2 ± 2	13 ± 2
20:4 n-6	5	6 ± 2	10 ± 4	2 ± 2	8 ± 1*
	20	10 ± 3	10 ± 1	2 ± 2	14 ± 3
18:3 n-3	5	5 ± 1	13 ± 1	0 ± 1	10 ± 2
	20	10 ± 2	15 ± 1	3 ± 1	12 ± 2
22:6 n-6	5	8 ± 2	13 ± 1	1 ± 2	10 ± 1*
	20	12 ± 3	9 ± 1	0 ± 3	13 ± 2

\* $P < 0.05$ , paired  $t$ -test

The weak affinity of all lactobacilli for the electron donor solvent (ethyl acetate) in comparison to the associated nonpolar solvent (octane) revealed a weak electron-accepting nature of the bacteria studied. Each bacterial strain adhered more to octane than to ethyl acetate; the phenomenon seen as low ethyl acetate / octane ratios (range 0.15 – 0.19). Only very few changes in ethyl acetate to octane ratios of different culture conditions were seen, and all significant changes seen were due to lowered adhesion to nonpolar octane. Interestingly, most of the changes in acidic characteristics (Figure 7B) were seen in *L. bulgaricus*; linoleic acid (5 µg / mL), γ-linolenic acid (20 µg / mL), arachidonic acid (at 5 and 20 µg / mL) and docosahexaenoic acid (20 µg / mL) reduced the ratio difference evaluated. Arachidonic (5 µg / mL) and linoleic acids (20 µg / mL) also resulted in lower ethyl acetate to octane ratio ( $p = 0.05$  and  $p < 0.01$ , respectively).

## 6.4 The effect of PUFA on functionality of probiotics (IV)

### 6.4.1 Bacterial growth and viability

The effects of free PUFAs in the growth medium on bacterial growth of *Lactobacillus rhamnosus* GG, *Lactobacillus casei* Shirota and *Lactobacillus bulgaricus* are presented in Table 16. In general, whenever influence on bacterial growth or viability was seen, the effects were dose-dependent.

Linoleic acid inhibited the growth of *L. casei* Shirota and *L. bulgaricus* at 40 µg / mL ( $P < 0.05$  and  $P < 0.02$ , respectively). γ-linolenic acid suppressed the growth of *L. casei* Shirota at 10 µg / mL or higher ( $P < 0.03$ ), *Lactobacillus* GG at 20 µg / mL or higher ( $P < 0.01$ ) and *L. bulgaricus* at 40 µg / mL ( $P < 0.05$ ), but promoted the growth of *L. casei* Shirota at 5 µg / mL ( $P < 0.05$ ). Arachidonic acid inhibited the growth of *L. casei* Shirota at 20 µg / mL or higher ( $P < 0.02$ ) and that of *Lactobacillus* GG at 40 µg / mL ( $P < 0.01$ ). α-linolenic acid suppressed the growth of *Lactobacillus* GG and *L. bulgaricus* at 20 µg / mL or higher ( $P < 0.05$  and  $P < 0.02$ , respectively), whilst the growth of *L. casei* Shirota was already inhibited at 10 µg / mL ( $P < 0.05$ ). Docosahexaenoic acid suppressed only the growth of *L. casei* Shirota at 40 µg / mL ( $P < 0.01$ ). Although PUFA at higher concentrations inhibited the growth of bacteria (seen as lowered % of final number of viable bacteria in Table 16), the viability of bacteria was not impaired. This was demonstrated by flow cytometric assessment of bacterial viability showing that over 95% of each bacterial strain possessed non-permeable cell membrane to propidium iodide and were regarded as viable.

A)

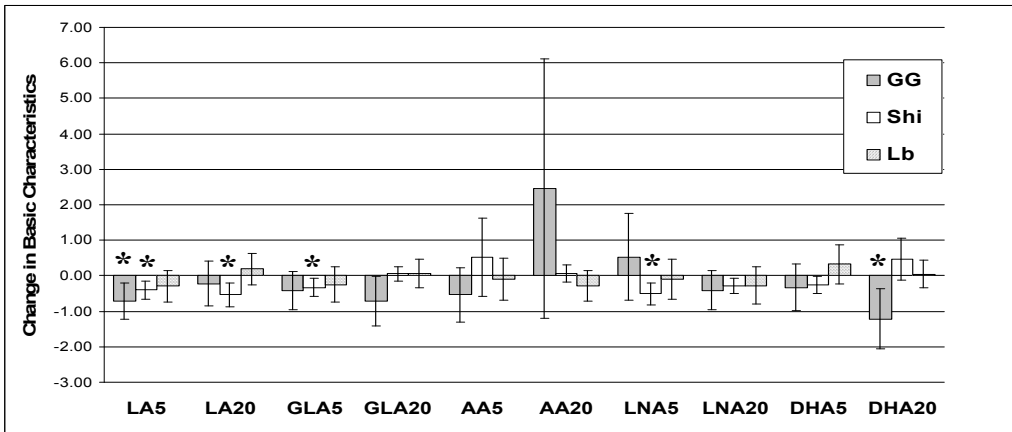

B)

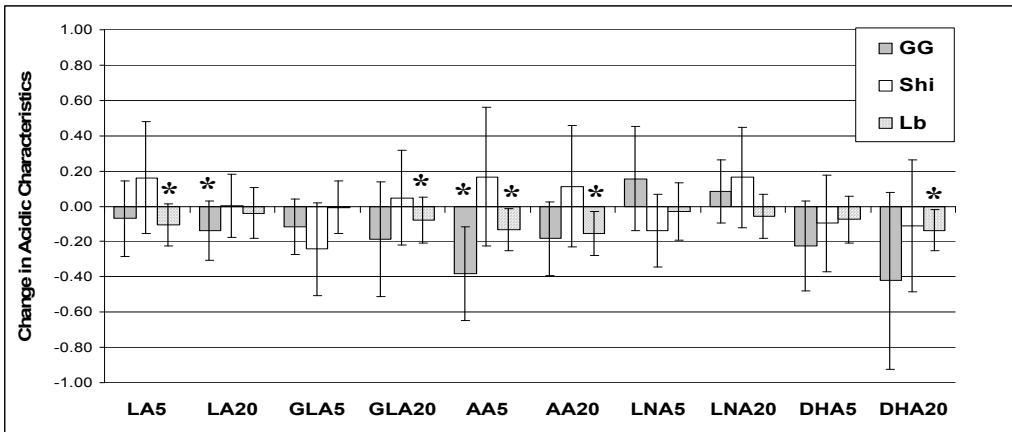

**FIGURE 7A & B.** The impact of different fatty acid supplementation on basic and acidic properties of *Lactobacillus rhamnosus* GG (GG), *Lactobacillus casei* Shirota (Shi) and *Lactobacillus bulgaricus* (Lb). The baseline A represents chloroform (CF) / tetradecane (C14) ratio of control cultures (no PUFA supplementation) and the bars represent the differences in CF / C14 ratios between test cultures (different PUFA supplementations) and control cultures. The baseline B represents ethyl acetate (EA) / octane (C8) ratio of control cultures and the bars represent the differences in EA / C8 ratios between test cultures and control cultures. Significant difference ( $p < 0.05$ ) is marked as \*. Other abbreviations; linoleic acid (LA),  $\gamma$ -linolenic acid (GLA), arachidonic acid (AA),  $\alpha$ -linolenic acid (LNA) and docosahexaenoic acid (DHA).

**TABLE 16.** The effect of different PUFA on viability of *Lactobacillus rhamnosus* GG, *Lactobacillus casei* Shirota and *Lactobacillus bulgaricus*. The percentage of final viable bacterial count was determined by using flow cytometric method; the number of viable bacteria was enumerated after culturing with different free PUFA at 5, 10, 20 and 40 µg / mL and finally compared to that of the control.

PUFA	µg/mL	<i>Lactobacillus</i> GG	<i>L. casei</i> Shirota	<i>L. bulgaricus</i>
		% viable count	% viable count	% viable count
Control	0	100	100	100
Linoleic acid (18:2 ω-6)	5	64	95	84
	10	79	62	77
	20	43	47	54
	40	8	7*	6*
γ-linolenic acid (18:3 ω-6)	5	142	153*	105
	10	41	51*	41
	20	8*	18*	13
	40	5*	9*	6*
Arachidonic acid (20:4 ω-6)	5	138	98	156
	10	119	57	148
	20	59	45*	74
	40	12*	14*	8
α-linolenic acid (18:3 ω-3)	5	36	55	81
	10	28	35*	43
	20	2*	10*	5*
	40	1*	6*	4*
Docosahexaenoic acid (22:6 ω-3)	5	58	78	63
	10	67	39	76
	20	75	67	62
	40	64	7*	45

\* significantly different from control (Student's t-test,  $P < 0.05$ )

#### 6.4.2 Bacterial mucus adhesion

The bacterial concentrations used in adhesion testing did not saturate the binding capacity of mucus isolate. Generally, higher doses of PUFA in the growth medium showed inhibitory effects on bacterial adhesion to human intestinal mucus (Table 17).

Linoleic acid in the growth media (40 µg / mL) inhibited the adhesion of *L. casei* Shirota ( $P < 0.02$ ). Arachidonic and γ-linolenic acid at 20 µg / mL or higher in the growth media inhibited the adhesion of *L. casei* Shirota ( $P < 0.01$  and  $P < 0.03$ , respectively) and *L. bulgaricus* ( $P <$

0.05 and  $P < 0.01$ , respectively), whereas the adhesion of *Lactobacillus* GG was suppressed by these PUFA only at 40  $\mu\text{g} / \text{mL}$  ( $P < 0.01$  for both). The adhesion of *L. casei* Shirota was markedly promoted by arachidonic acid at 10  $\mu\text{g} / \text{mL}$  in growth media ( $P < 0.05$ ). The presence of  $\alpha$ -linolenic acid in growth media inhibited the adhesion of *Lactobacillus* GG at 20  $\mu\text{g} / \text{mL}$  or higher ( $P < 0.05$ ), whilst 40  $\mu\text{g} / \text{mL}$  of  $\alpha$ -linolenic acid was needed to inhibit the adhesion of *L. casei* Shirota ( $P < 0.001$ ) and *L. bulgaricus* ( $P < 0.01$ ). Docosahexaenoic acid suppressed the adhesion properties of *L. casei* Shirota at 10  $\mu\text{g} / \text{mL}$  or higher ( $P < 0.03$ ), that of *Lactobacillus* GG at 20  $\mu\text{g} / \text{mL}$  or higher ( $P < 0.01$ ), and that of *L. bulgaricus* at 40  $\mu\text{g} / \text{mL}$  ( $P < 0.02$ ).

## 6.5 The effect of PUFA on functionality of intestinal epithelia (IV)

### 6.5.1 Bacterial Caco-2 adhesion

Intestinal epithelial cells were also affected by PUFA, as demonstrated by the variation in bacterial adhesion to differentially cultured Caco-2 cells (Figure 8).

Culturing of Caco-2 cells in the presence of linoleic acid,  $\gamma$ -linolenic acid, arachidonic acid and docosahexaenoic acid reduced the adhesion of *Lactobacillus* GG (Figure 8A). *L. casei* Shirota and *L. bulgaricus* adhered less on Caco-2 cells grown in the presence of arachidonic acid (Figure 8B and 8C, respectively). However, Caco-2 cells grown in the presence of  $\alpha$ -linolenic acid were able serve more adhesion sites for *L. casei* Shirota compared to control (Figure 8B).

**TABLE 17.** The effect of different PUFA on growth and adhesion to mucus (isolated from healthy infants' faeces) of *Lactobacillus rhamnosus* GG, *Lactobacillus casei* Shirota and *Lactobacillus bulgaricus*.

PUFA	$\mu\text{g/mL}$	<i>Lactobacillus</i> GG		<i>L. casei</i> Shirota		<i>L. bulgaricus</i>	
		Number of adhered bacteria mean (S.D.)	Adh. %	Number of adhered bacteria mean (S.D.)	Adh. %	Number of adhered bacteria mean (S.D.)	Adh. %
Control	0	4,7E+6 (7,9E+5)	15,8	3,4E+6 (3,4E+6)	2,8	1,1E+7 (3,9E+5)	16,1
Linoleic acid (18:2 $\omega$ -6)	10	3,7E+6 (6,0E+5)	12,4	2,4E+6 (1,1E+6)	2,6	8,9E+6 (1,3E+6)	13,0
	20	3,1E+6 (1,7E+5)	10,3	6,3E+6 (5,2E+6)	7,0	9,5E+6 (4,8E+6)	13,9
	40	3,7E+6 (1,5E+6)	12,5	7,0E+5 (5,4E+5)	0,8*	1,0E+7 (6,3E+6)	15,2
$\gamma$ -linolenic acid (18:3 $\omega$ -6)	10	3,3E+6 (6,2E+5)	11,0	2,0E+6 (1,4E+6)	2,2	1,2E+7 (6,6E+5)	16,9
	20	3,5E+6 (7,5E+5)	11,6	1,5E+5 (3,2E+4)	0,2*	4,9E+6 (2,1E+6)	7,2*
	40	9,8E+5 (1,3E+5)	3,3*	1,6E+5 (9,5E+4)	0,2*	8,9E+5 (3,7E+5)	1,3*
Arachidonic acid (20:4 $\omega$ -6)	10	4,6E+6 (1,5E+6)	15,5	1,5E+7 (7,6E+6)	16,2*	8,2E+6 (1,1E+6)	12,0
	20	4,4E+6 (1,5E+6)	14,6	1,2E+5 (6,3E+4)	0,1*	4,7E+6 (3,3E+6)	6,9*
	40	1,5E+6 (8,1E+5)	5,1*	1,6E+5 (7,3E+4)	0,2*	6,7E+6 (2,9E+6)	9,8*
$\alpha$ -linolenic acid (18:3 $\omega$ -3)	10	3,9E+6 (1,1E+6)	13,2	5,0E+6 (4,0E+6)	5,6	9,8E+6 (2,0E+6)	14,3
	20	3,0E+6 (1,0E+6)	10,0*	1,6E+6 (1,1E+6)	1,8	9,9E+6 (4,9E+6)	14,5
	40	9,2E+5 (7,1E+5)	3,1*	1,9E+5 (1,9E+5)	0,2*	2,3E+6 (1,8E+6)	3,4*
Docosahexaenoic acid (22:6 $\omega$ -3)	10	4,7E+6 (1,1E+6)	15,7	3,5E+5 (3,5E+5)	0,4*	1,2E+7 (2,9E+6)	16,7
	20	3,0E+6 (1,2E+6)	9,9*	1,6E+5 (3,8E+4)	0,2*	6,4E+6 (2,9E+6)	9,4
	40	5,9E+5 (7,6E+5)	2,0*	1,5E+5 (4,9E+4)	0,2*	5,6E+5 (1,1E+5)	0,8*

\* Significantly different from control (Student's t-test,  $P < 0.05$ )

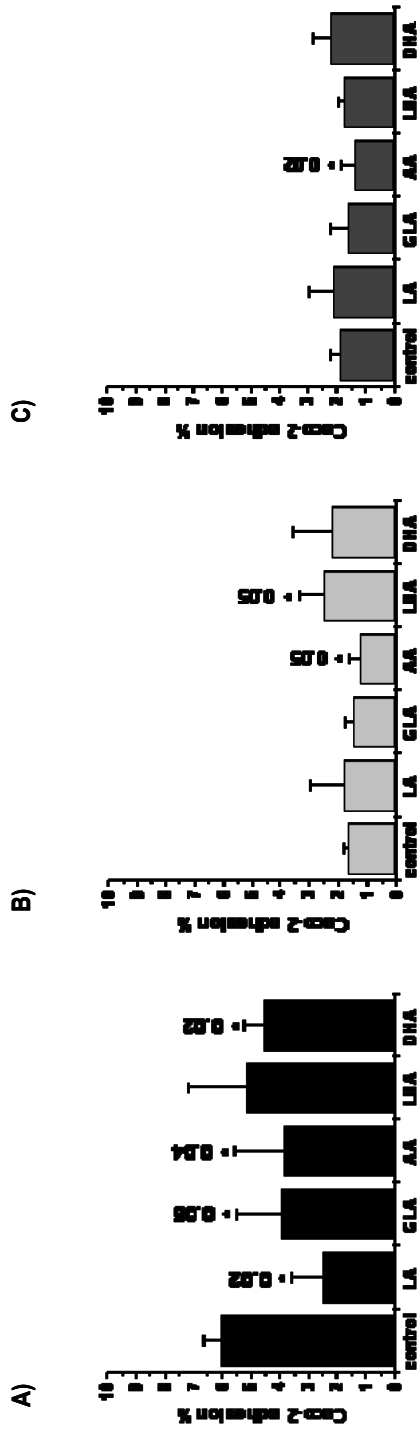

**FIGURE 8.** Adhesion of *Lactobacillus* GG (A), *L. casei* Shirota (B) and *L. bulgaricus* (C) to human intestinal epithelial Caco-2 cell monolayers cultured with 10  $\mu\text{g ml}^{-1}$  of linoleic (LA),  $\gamma$ -linolenic (GLA), arachidonic (AA),  $\alpha$ -linolenic (LNA) or docosahexaenoic acid (DHA). \* Indicate statistically significant differences compared to the unsupplemented medium.



## 7 DISCUSSION

Western lifestyle has been proposed to be responsible for increasing the susceptibility to atopic sensitization (ISAAC 1998). One explanation for such a development is hygiene hypothesis (Strachan 1989). This hypothesis suggests that atopic sensitization arises from impaired development of oral tolerance due to reduced exposure to infections early in life. Related to this concept, the proper development of gut microbiota has also been shown to be of importance (Isolauri and Salminen 2008), and subsequently probiotic interventions have been suggested and shown effective in the promoting the maturation of immune responsiveness to ubiquitous antigens (e.g. common food antigens and normal microbiota). Another proposed life-style related explanation is the dietary hypothesis, according to which the increased prevalence of atopic diseases has been linked to several dietary factors. Especially the increased and/imbalance consumption of polyunsaturated fatty acids have been linked to increased risk of atopy (Black and Sharpe 1997, Simopoulos 2002, 2008). To elaborate this hypothesis, in particular the anti-inflammatory potential of n-3 PUFA has been intensively studied. Recent evidence suggests that both probiotics and PUFA do possess potential benefits, especially in relation to allergies, and their modes of action share similar mechanisms. Although PUFA and probiotics in the management of allergy have usually been considered separately, we have studied here whether these two factors may interact with each other.

### 7.1 PUFA as a dietary factor (I)

In study I, we studied the maternal diet, breast milk and serum lipid fatty acids in relation to atopic status of both mother and infant. Dietary intake of various fats was found to resemble those reported in Europe (Saadatian-Elahi et al. 2009, Hoppu et al. 2000, Francois et al. 1998). As opposed to the findings of Hoppu and co-workers (2000), no differences were found between energy intake and PUFA consumption based on mother's allergy status. This discrepancy may be due to extensive intake variations seen in our study, especially in PUFA intake. However, when food records were assessed in terms of infant's allergy status (irrespective of mothers' allergic status), similar to Hoppu and co-workers (2000), we showed that mothers of atopic infants consumed more fat and less linoleic acid in their diet compared to their counterparts. In relation to general findings of modern western diet (Simopoulos 2008), the n-3 PUFA intake was low in our study (only 8/28 mothers consumed some oily fish during the recording days). There is now increasing evidence that consumption of foods

or supplements rich in n-3 fatty acids may protect against asthma in childhood (Hodge et al. 1996, Koletzko et al. 2008). In support to this, we showed in Study I that only 2 out of 8 children whose mothers consumed oily fish during breastfeeding developed atopic disease during the first three months (mothers of these infants were atopic themselves). However, the timing of n-3 PUFA consumption or supplementation may be of importance. Similar results have been reported by Olsen and coworkers (2008), who have recently shown that high dietary n-3 PUFA consumption late in the pregnancy did reduce the hazard rates of asthma and allergic asthma of their children (assessed when the children were 16 years old) by 63% and 87%, respectively (Olsen et al. 2008).

Human breast milk is especially rich in lipids that originate from dietary sources, endogenous stores as well as liver and breast tissue synthesis. The endogenous stores and synthesis are utilized when excess energy is consumed, whereas dietary fatty acids are generally transferred very fast to breast milk (Francois et al. 1998, Demmelmair et al. 2001). In this study, we found a significant correlation between maternal diet and breast milk content of SFA, but could not demonstrate correlation between dietary PUFA and breast milk PUFA. Therefore, the breast milk PUFA profile shown in our study most probably resembles more the general fatty acid status of the mothers. Overall, it appears that maternal diet during breast feeding does influence the fatty acid composition of breast milk, but equal emphasis must be given to maternal diet during the pregnancy as these endogenous fatty acid stores may influence the transfer of lipids into breast milk even during lactation.

PUFA content in breast milk has been demonstrated to differ in terms of allergy status of mother (Yu et al. 1998a, Duchon et al. 1998, Businco et al. 1993), and this disturbance has been linked to impaired  $\Delta$ -6 desaturase (Yu et al. 1998a, Calder 2006b). In our study (I), we demonstrated that breast milk from healthy mothers contained more  $\gamma$ -linolenic acid and less docosahexaenoic acid than breast milk of allergic mothers, also seen as higher n-6 to n-3 PUFA ratio in healthy. However we did not detect any difference in linoleic acid or in longer chain n-6 PUFA proportions. Thus our findings do not support the impaired desaturation and elongation hypothesis, but rather suggests that PUFA composition differences of breast milk noted between healthy and atopic mothers may be more a reflection of endogeneous utilization of especially n-6 PUFA by atopic mothers.

PUFA content in breast milk has also been studied in terms of allergy status of the infant/children, but the comparison of these studies is somewhat more difficult due to the differences in study designs and clinical endpoint definitions. In these studies, the allergic status of the mothers has been either fixed (Hoppu et al. 2005, Oddy et al. 2006, Laitinen et al. 2006), there have been two groups of mothers, i.e. allergic and non-allergic (Duchen et al. 1998, our study), or the allergic status of mother has not been taken into account (Stoney et al. 2004, Lowe et al. 2008). Since PUFA (especially longer chain n-6 PUFA) may be utilized by inflammatory processes of allergic mother rather than transferred to breast milk, the allergic status of mother, and perhaps type of allergy, may well be the most critical factor influencing the breast milk PUFA levels (Black and Sharpe 1997, Calder 2006b). These differences do explain the contradictory results evinced in these studies. In terms of these factors, the work carried out by Duchen and co-workers (1998) resembles the best study reported here (I). They showed that low levels of  $\alpha$ -linolenic acid and total n-3 PUFA in mature milk were associated with atopic sensitization early in life (Duchen et al. 1998). Our results are in concordance with their findings, even though our findings are not so profound; we showed that non-atopic infants receive via breast significantly less n-6 PUFA, evinced as lower n-6 to n-3 ratio, than atopic infants. In studies with allergic mothers, higher ratio of SFA to PUFA, less n-3 PUFA and increased n-6 to n-3 PUFA ratio in breast milk has been associated with development atopic dermatitis in infants (Hoppu et al. 2005) and non-atopic eczema of children at the age of 5 years (Oddy et al. 2006). In the latter, no differences in breast milk PUFA were observed in terms of atopic eczema. The PUFA association findings in these two studies are substantial, however the endpoints do differ (atopic dermatitis vs. atopic and non-atopic eczema, respectively). In contrast, with the similar study design, Laitinen et al. (2006, 2006b) showed lowered linoleic acid, total PUFA, and sum of n-6 PUFA in breast milk received by infants with atopic eczema. Mothers in this study were diagnosed with atopic disease (incl. asthma, atopic eczema, allergic rhinitis). These findings can not substantiate the theory of endogenous utilization of PUFA by allergic mothers, because these results are based on infants' allergic status only, and obviously the mother's atopic status is of importance as well. These results, however, indicate that unbalanced PUFA composition of breast milk (either n-6 or n-3 PUFA skewed) may predispose the infants to the different types of allergic diseases (Laitinen et al. 2006b). To highlight this suggestion, in yet another study set-up (high risk cohort), Stoney and co-workers (2004) showed that higher n-3 PUFA levels in the colostrum are associated with the eventual development of atopy in high-risk breastfed infants, and in the follow-up study, Lowe and the co-workers (2008) showed a more fine-tuned analysis in which the total

n-3 intake in breast milk was associated with increased risk of non-atopic eczema (OR=1.60, 95% CI=1.03-2.50), whereas higher levels of total n-6 PUFA were associated with increased risk of childhood rhinitis (OR=1.59, 95% CI=1.12-2.25). This study could not find any differences in PUFA of breast milk in relation to risk of asthma. We can relate our study to the latter study design by taking into account both mother's and infant's atopic status. In our study, allergic mothers with atopic infants had low n-6 to n-3 PUFA ratio.

As a summary, studies that have investigated the role of PUFA in breast milk in relation to allergies have only been able to show minor changes between studied groups, though it has to be acknowledged that even small differences of such potential lipids as PUFAs may be physiologically important (Calder 2006b). The more recent studies investigating the PUFA profiles of breast milk do not support the hypothesis of impaired desaturation and elongation enzyme activities in atopic subjects, but rather point out to the imbalance of PUFA utilization in allergic individuals (Sala-Vila et al 2008). In other words, PUFA (especially longer chain n-6) may be utilized by inflammatory process of allergic mother rather than transferred to breast milk. This conclusion is further supported by recent findings of Laitinen et al. (2006) showing that specific breast milk PUFA correlate with PGE<sub>2</sub> and soluble CD14 levels in maternal serum, indicating that dietary PUFA may contribute to the regulation of innate and adaptive immune responses and link intraluminal exposures, mother's diet, and microbes. Moreover, the studies investigating the role of breast milk PUFA composition on atopic sensitization vary greatly in terms of their study designs (collection time, collection intervals etc.), which make the direct concentration comparison of obtained breast milk PUFA levels difficult.

There is epidemiologic evidence linking the increase in n-6 PUFA consumption to atopic sensitization (Black and Sharpe 1997, Nagagomi et al. 1994, Simopoulos 2002, 2008), evinced as altered serum PUFA profiles in atopic subjects (Yu et al. 1998b, Manku et al. 1984). Similar to breast milk PUFA disturbances, the common theory to explain serum PUFA abnormalities have been explained by impaired function of  $\Delta$ -6 desaturase in atopic subjects (Yu et al. 1998b, Manku et al. 1984, 1982), though controversial conclusions have also been suggested (Leichsenring et al. 1995, Calder 2006b). In our study, the serum lipid fatty acids of especially TG and CE fractions in atopic and healthy infants were in accordance with earlier reported findings (Yu et al. 1998b, Leichsenring et al. 1995). We showed that atopic infants had higher levels of n-6 PUFA paralleled by lower n-3 PUFA indicating that dietary (i.e.

exclusively breast-fed) intake of PUFA was n-6 PUFA skewed. Still, only  $\gamma$ -linolenic acid proportions were lower in serum PL of atopic infants compared to healthy infants, whereas other n-6 PUFA were comparable to levels seen in serum PL of healthy infants. Thus, our results suggest that elongation and desaturation of PUFA in serum PL is not impaired, a conclusion supported by Focke and co-workers (2005). Rather, these findings suggest that (i) incorporation of longer chain n-6 PUFA into serum PL may be hindered, or (ii) these fatty acids may be utilized for other purposes in atopic individuals. Either theory has not been proven as yet. However, the recent findings of Olsen and co-workers (2008) demonstrated that n-3 PUFA supplementation started during the pregnancy do reduce the hazard rate of asthma (at 16 years of age) significantly. In other words, the dietary PUFA balance of the mother already during the pregnancy may influence the tissue fatty acid pools of the developing fetus. This initial establishment of PUFA balance in developing infant may be of great importance, as the available human data suggests that the amount of e.g. arachidonic acid formed by interconversion normally exceeds the dietary intake (Zhou and Nilsson 2001). Moreover, it is also known that even though desaturation and elongation of PUFA occur in newborn the rate of these reactions are generally regarded very low (Koletzko et al. 2008). Therefore, the n-6 and n-3 PUFA profiles of the infants have been suggested to be more a reflection of PUFA accumulation *in utero* (via placental transfer of maternal PUFA from either storage tissues or diet) rather than a function of maternal diet during the first months of life of the newborn (Innis 2005, Kraus-Etschmann et al. 2007). This hypothesis also could explain why the results of studies linking various PUFA levels and allergies, and those studying the efficacy of n-3 PUFA anti-inflammatory properties after birth vary greatly – the endogenous tissue fatty acid pools of modern human being are already so n-6 PUFA skewed (due to Western diet) and this imbalance tend to limit the potential changes associated with dietary n-3 PUFA interventions. There are now recent findings that favor the above hypothesis showing that maternal n-3 PUFA supplementation during the pregnancy decreased the risk of food allergy and IgE-associated eczema during the first year of life in infants with a family history of allergic disease (Furuhjelm et al. 2009) and may alleviate certain immune responses (e.g. PGE<sub>2</sub>) involved in allergic inflammation (Warstedt et al. 2009).

## 7.2 Effects of probiotics on plasma lipid profiles of infants (II)

As the intestinal microbiota is an important constituent of the gut mucosal barrier by affecting the development of oral tolerance, oral introduction of probiotics have been suggested to aid

in host protection against allergic sensitization (Isolauri and Salminen 2008). Indeed, recent data have substantiated this hypothesis by demonstrating the clinical efficacy of probiotic supplementation in atopic and food allergic infants (Kalliomäki et al. 2001b, 2003, 2007). At the same time, substantial increase in consumption of n-6 PUFA has occurred (also observed here in study I) and this has been linked to increased inflammatory reactions leading to atopic sensitization (Black and Sharpe 1997, Simopoulos 2002, 2008).

There are indications that intestinal bacteria may interact with different fatty acids. Particularly, probiotics have been reported to possess cholesterol-lowering properties in man and in animals (St-Onge et al. 2000, Kamlage et al. 1999, 2000, Ringo et al. 1998). Also, direct assimilation of cholesterol from growth medium by specific lactobacilli has been demonstrated to coincide with lowered cholesterol levels following the consumption of lactobacilli (Noh et al. 1998, Dambekodi et al. 1998, Grill et al. 2000, Pereira and Gibson 2002). In relation to cholesterol lowering capacity, dairy starter cultures have also been shown to possess ability to produce CLA from free linoleic acid *in vitro* (Jiang et al. 1998). As for functional interactions between probiotics and PUFA, the most frequently reported effect is the bacteriocidal activity (Burt 2004) and bacterial stress responses (Piuri et al. 2005, Guerzoni et al. 2001). In relation to functional implications of the above findings, it can be suggested that dietary PUFA may interfere the establishment of normal intestinal microbiota, or that probiotics could influence the utilization of dietary PUFA. In study II, we investigated the latter, i.e. whether probiotics in extensively hydrolyzed infant formula affect the plasma lipids in atopic infants. Of utmost importance is the notion that both in this study as well as elsewhere, the infant formulas fortified with probiotics have been shown to be safe (Isolauri et al. 2000, Gibson et al. 2009). Moreover, in this study, we investigated only a small fraction of the samples of the entire cohort (Isolauri et al. 2000), in which this particular probiotics supplementation was shown to be efficient modifying the changes related to allergic inflammation. Therefore, the results of the study II can only be regarded as demonstrative.

The fatty acid composition of the extensively hydrolyzed formula was reflected in their plasma lipid composition, indicating substantial shift in their diet from breast milk to the intervention formulas. In comparison to regular formula, probiotics supplemented formulas resulted in some specific changes in plasma lipids of atopic infants. Especially, the probiotic formulas influenced the proportions of n-3 PUFA in neutral lipids; both *Bifidobacterium* Bb-12 and *Lactobacillus* GG supplemented formulas both reduced the proportion of  $\alpha$ -linolenic

acid. In addition, *Lactobacillus* GG supplemented formula also lowered total n-3 PUFA proportions and subsequently increased n-6 to n-3 PUFA ratio in neutral lipids. In contrast to these findings, the both probiotic supplemented infant formulas had either no effect (*Lactobacillus* GG supplemented formula) or even increased the proportion of  $\alpha$ -linolenic acid in PL (*Bifidobacterium* Bb-12 supplemented formula). Still, the n-6 to n-3 PUFA ratio in PL increased in *Lactobacillus* GG supplemented formula group due to a lowered eicosapentaenoic acid proportion. As far as known, this study remains the only study showing that the use of probiotic supplemented infant formula resulted in altered plasma lipid PUFA composition when compared to a regular, non-probiotic-supplemented formula. This finding may have mechanistical implications to the probiotic therapy in general. The entire cohort showed that 2 months supplementation of the very same probiotic fortified infant formulas significantly improved patient skin conditions as compared to the un-supplemented group in parallel with a reduction in the concentration of soluble CD4 in serum and eosinophilic protein X in urine (Isolauri et al. 2000). Whether this clinical efficacy of the larger cohort was due to probiotics only or mediated by probiotics-PUFA interactions (e.g. probiotics may assimilate certain PUFA in formula before the consumption or exert their effect via regulation of absorption and metabolism of PUFA in gut) remains unknown. However, partly based on our findings, it has been suggested that the efficacy of probiotic supplemented infant formulas may be potentiated by fine-tuning their PUFA composition (Bomba et al. 2002a&b, Das 2002). Clearly, these findings need to be further characterized but the results presented here open up an interesting perspective for the future when new, probiotics based functional foods are designed.

### 7.3 Effects of PUFA on physicochemical properties of probiotics (III)

In study III, we investigated here whether specific probiotic strains could incorporate exogenous free PUFA into bacterial lipids, and whether exogenous free PUFA influence the hydrophobicity of the lactobacilli, a characteristic suggested to be important in the adhesion, and subsequent temporary colonization, of probiotic bacteria (Vinderola et al. 2004, Wadström et al. 1987, Fernandez Murga et al. 2000). In general, however, the investigations with regard to the effects of PUFA on physicochemical properties of lactobacilli are scarce, though there is some evidence suggesting that bacteria could take up exogenous PUFA present in the culture medium (Watanabe et al. 1994), and even possess the metabolic capacity to synthesize PUFA (Russell and Nichols 1999).

In normally grown lactobacilli, the four major fatty acid classes analyzed, making up 65-75% of the cellular fatty acid pool, were  $\Sigma$ SAFA, oleic acid, vaccenic acid and dihydrosterculic acid, all of which have been previously reported in lactobacilli (Dionisi et al. 1999, Fernandez Murga et al. 2000, Gomez Zavaglia et al. 2000, Jenkins and Courtney 2003). Of these oleic and vaccenic acids (in some reports, notion 18:1 includes both) seem to be the most predominant in lactobacilli making up 14 – 67 % of total fatty acids (Gomez Zavaglia et al. 2000, Jenkins and Courtney 2003). The large range in the results has been attributed to differences in culture temperature and incubation time, culture medium and strains used in different studies. The relatively high level of oleic acid in cellular fatty acids of all tested lactobacilli in our study is most probably a reflection of the culture media used (MRS broth used is rich in oleic acid). Contrary to the previous reports (Wynn and Ratledge 2000, Partanen et al. 2001) we demonstrated the varying proportions of vaccenic acid in the bacterial fatty acids suggesting that the *de novo* fatty acid biosynthesis is not repressed by high level of oleic acid in the growth media. Similarly, previous reports have regarded dihydrosterculic and lactobacillic acids, formed by methylation of oleic and vaccenic acids, respectively, as the major fatty acids in lactobacilli (Dionisi et al. 1999, Guerzoni et al. 2001, Johnsson et al. 1995, Suutari and Laakso 1992), however, we could not identify lactobacillic acid in *L. bulgaricus* nor in *L. casei* Shirota, and found it only in trace amounts in *Lactobacillus* GG. This finding is, however, in agreement with previous studies showing that the low availability of oleic acid in the culture medium (e.g. whey culture medium) would increase the cellular levels of lactobacillic acid (Guerzoni et al. 2001), whilst high availability of oleic acid (e.g. Tween-80 in MRS medium) increases the levels of dihydrosterculic acid (Johnsson et al. 1995).

Linoleic acid, though fairly uncommon, has been identified in cellular fatty acids of lactobacilli, the proportions ranging from trace amounts up to 20 % (Dionisi et al. 1999, Guerzoni et al. 2001, Gomez Zavaglia 2000). We did not identify this parent n-6 PUFA in bacterial fatty acids at all when bacteria were grown in standard MRS media (i.e. without PUFA supplementation). However, we did identify  $\gamma$ -linolenic acid and eicosapentaenoic acid in all lactobacilli.  $\alpha$ -linolenic acid and docosahexaenoic acid were also recognized though the precise quantification of their proportions was impossible due to overlapping chromatograms. We also did identify CLA (predominantly c-9,t-11 and t-10, c-12 isomers) in bacterial lipids,



the finding that is supported by various other studies (Jenkins and Courtney 2003, Van Nieuwenhove et al. 2007, Lee et al. 2003, Alonso et al. 2003). This may prove important since the synthetic and natural sources of CLA may have beneficial effects in a range of inflammatory conditions including colitis, atherosclerosis, metabolic syndrome and rheumatoid arthritis (Reynolds and Roche 2010) as well as modulate the body composition and lipid profiles in human (Baddini Feitoza et al. 2009). Whether the identified CLA seen are naturally present in fatty acids of lactobacilli or assimilated from the culture medium can not be answered firmly, but the differences seen in cellular CLA levels especially when lactobacilli were grown with added PUFA substrates suggest that some inter-conversion reactions do happen. Therefore, it is likely that CLA isomers may indeed be part of a normal cellular fatty acid profile of the lactobacilli. Moreover, there is now increasing evidence that lactobacilli do not only convert parent PUFA to CLA via interconversion reactions but also can produce extracellular CLA (Alonso et al. 2003) and this property is even potentiated when lactobacilli are grown in more richer media, i.e. milk, by two- to three-fold (Van Nieuwenhove et al. 2007). Clearly, this property of lactobacilli may offer yet another possible mechanism to increase the levels of potentially beneficial compounds in dairy products and functional foods.

When growth media was supplemented with free PUFA, especially those of n-6 series were readily assimilated by all three lactobacilli tested. In addition, complex PUFA dependent differences were also observed in other cellular fatty acids suggesting that the bactericidal stress applied (Burt 2004) could be balanced by fatty acid interconversion reactions (Guerzoni et al. 2001, Johnsson et al. 1995). As a general trend, an increase in unsaturation level of fatty acids as a response to exposure to free extracellular PUFA was observed. This may suggest that desaturase activation or hyperinduction may play an important role in response to the stress applied. Indeed, there is experimental evidence that anaerobic lactobacilli (*Lactobacillus helveticus*) may possess oxygen-consuming desaturase-system to cope with environmental stress (Guerzoni et al. 2001). In accordance to this, we demonstrated in this study that also *Lactobacillus rhamnosus* (GG), *Lactobacillus casei* (Shirota) and *Lactobacillus delbrueckii* (subsp. *bulgaricus*) do possess similar activity, even though particularly *Lactobacillus delbrueckii* has previously been suggested to lack such a enzymes responsible for *de novo* synthesis of long chain PUFA (Partanen et al. 2001). However, it must be emphasized that studies on the biosynthetic routes of fatty acids in lactobacilli are still few (Guerzoni et al. 2001, Johnsson et al. 1995, Suutari and Laakso 1992). Further

characterization of the biosynthetic routes of fatty acids in lactobacilli is therefore clearly warranted.

The microbial adhesion process have been postulated to include passive forces, such as hydrophobic and steric forces as well as specific structures such as lipoteichoic acids, lectins and extracellular polymers (Gusils et al. 2002). In the present study, all bacteria showed only slight hydrophobic properties, and the hydrophobicity tended to decrease when bacteria were cultivated in medium supplemented with extracellular PUFA. Moreover, lactobacilli had very weak electron-accepting nature indicating non-acidic character of the bacteria. Even though the hydrophobic lactobacilli may adhere better to intestinal epithelial cells than hydrophilic strains (Wadström et al 1987), our findings indicate that alteration in fatty acid composition of probiotics may predominantly influence other factors associated with microbial adhesion process, probably via influencing the bacterial membrane fluidity and membrane-lipopeptide interactions (Gusils et al. 2002). More recently, as part of comparative genome analysis of *Lactobacillus rhamnosus* GG and *Lactobacillus rhamnosus* LC705 (two lactobacilli strain know to possess different adhesion properties), genes coding pilins were found only in *Lactobacillus rhamnosus* GG. These where shown to be physically on the surface of *Lactobacillus rhamnosus* GG and effectively mediating the mucus-binding of the bacteria, revealing a previously undescribed mechanism for the interaction of selected probiotic lactobacilli with host tissues (Kankainen et al. 2009).

#### **7.4 Effects of PUFA on functionality of probiotics (IV)**

Dairy products, the most commonly used delivery vehicle of probiotics, have a distinct texture and composition, and promote the passage of viable strains through acidic conditions in the stomach (Goldin et al. 1992). Dairy products also contain PUFA and thus, the question can be asked whether they are optimal carriers for probiotics? In the previous studies we have shown that PUFA are important factors in relation allergy (I), and that probiotics may affect the utilization of dietary PUFA (II). In addition, we have shown that PUFA does influence the physicochemical properties of probiotics (III), some of which are linked to functional characteristics of probiotics. As the ability to permanently, or at least temporarily, adhere to intestinal mucosal surfaces appears to be an important aspect for optimal function of probiotics (Tuomola et al. 2001, Salminen et al. 2005), we investigated in study IV whether

PUFA in growth media could influence the functional properties (growth and adhesion) of commonly used probiotics.

In accordance with previous findings (Jenkins and Courtney 2003, Partanen et al. 2001), we demonstrated the bactericidal activity of PUFA. All tested free PUFA affected the growth of *L. casei* Shirota, *L. bulgaricus* and *Lactobacillus* GG in a dose and strain dependent manner. Although PUFA at high concentrations (40 µg / mL) generally inhibited the bacterial growth, some promotion effects were also evinced; γ-linolenic was found to significantly promote the growth of *L. casei* Shirota at low concentrations. Flow cytometric assessment of permeability of bacterial cell wall indicated that most of the bacteria (>95%) were intact still after grown in PUFA supplemented media, suggesting that PUFA are not lethal to lactic acid bacteria but most probably inhibit the normal bacterial cell cycle.

We confirmed the previously reported mucus adhesion potential of the tested strains (Kirjavainen et al. 1998, Tuomola et al. 2001). In addition, we have shown here that free PUFA in growth media could influence mucus adhesion properties of lactic acid bacteria. In general, different levels of free PUFA in growth media inhibited bacterial mucus adhesion. However, promotional effects were also seen, the one of which was shown to be statistically significant; arachidonic acid (10 µg / mL) promoted the mucus adhesion of *L. casei* Shirota. As mucus adhesion is the first step in persistence, the inhibited mucus adhesion shown here might reduce the number of bacteria able to adhere to epithelial cells, a key step for the health promoting functions of probiotics.

Dietary PUFA have been linked to microbiota development in some *in vivo* animal studies. Namely, Ringo et al. (1998) have demonstrated the efficacy of dietary n-3 PUFA in promotion of lactic acid bacteria populations in fish, and Bomba and co-workers (2002) have shown that PUFA fortified nutrition increase the number of *L. paracasei* adhering to jejunal mucosa of gnotobiotic piglets. These authors suggested that PUFA could modify adhesion sites for gastrointestinal microorganisms by changing membrane fatty acid composition of the intestinal epithelial cells. In addition, n-6 PUFA have been shown to up-regulate epithelial permeability and inflammation associated with mucosal damage (Ohtsuka et al. 1997). Our *in vitro* Caco-2 cell adhesion data do support the above findings. We showed that characteristics of Caco-2 cells involved in bacterial adhesion process can be modified with PUFA; culturing

of Caco-2 cells with arachidonic acid reduced the Caco-2 cell adhesion of all lactobacilli, whereas e.g.  $\alpha$ -linolenic acid, the parent n-3 PUFA, did not interfere with Caco-2 cell adhesion of *Lactobacillus* GG or *L. bulgaricus*, and even promoted that of *L. casei* Shirota. Overall, especially n-6 PUFA seem to inhibit bacterial adhesion onto Caco-2 cells, whereas n-3 PUFA have only substantial effects. Although studies have shown that certain long chain fatty acids (especially docosahexaenoic acid) can induce apoptosis in cancer cells (e.g. Caco-2 cells) (Engelbrecht et al 2008), the results of our study can not be contributed to this phenomenon (used PUFA levels were too low) but express alterations in Caco-2 capacity to serve adhesion sites.

Probiotics are commonly introduced in specific carriers, such as fermented dairy products, in which the concentrations of free PUFA may exceed even 400  $\mu\text{g} / \text{mL}$  (Kabara et al. 1972). This figure, however, may be considered as an overestimate as this does not take into account the dilution factor and the rapid absorption process of fatty acid. In our study, we showed that physiologically relevant levels of free PUFA may influence the functions of probiotics (growth and adhesion) and intestinal epithelia (adhesion). Based on the data shown in this study, it could be hypothesized that inhibition of adhesion (via changing both bacterial and epithelial characteristics) by specific PUFA may indicate that dietary PUFA could indirectly influence the normal development of intestinal microbiota and thus promote/inhibit the maturation of the intestinal barrier functions. In this context, it has been known for long that breast-fed and formula-fed infants do have different intestinal microbiota (Benno et al. 1984, Harmsen et al. 2000), especially in terms of bifidobacteria. But it is also evident, that these two modes of nutrition have been different (and still are to some extent) in terms of their PUFA profiles (formulas generally lack the longer chain PUFA even early 2000) (Koletzko et al. 2008). Even though it is now known that breast milk itself can be a source of bifidobacteria and lactobacilli thus promoting the development of intestinal microbiota (Collado et al. 2009), in the light of our mechanistic findings, the different PUFA composition of these breast milk and formula milk suggest another factor attributing to the differential development of microbiota, suggestion supported by animal studies (Ringo et al. 1998, Bomba et al. 2002, Hekmatdoost et al. 2008) and by very recent human study indicating that that breast milk may affect the colonization of lactobacilli (Abrahamsson et al. 2009). In the view of our results and available published research data, dietary PUFA may indeed influence the development of microbiota.

## 8 CONCLUSIONS

During the execution of this study we demonstrated the carry-over effect of dietary fatty acids from maternal diet via breast milk into infants' serum lipid fatty acids, we investigated the incorporation of PUFA into lipids of infants and the effect of probiotics in formula and began to deduce the effects of PUFA on physicochemical, growth and adhesion properties of probiotics.

With respect to Study I, the previously shown allergy -related PUFA level imbalances in fatty acid profiles of both breast milk and serum fractions were observed. However, our data was not in complete agreement with the impaired desaturation and elongation capacity hypothesis suggested previously. Rather, our data support the hypothesis which suggest that instead of transferring n-6 PUFA acids into breast milk in mothers or incorporating them into membrane PL in infants, n-6 PUFA are utilized for other purposes, e.g. as PG and LT precursors, in atopic individuals. Modern diet rich in n-6 fatty acids may therefore predispose infants to atopic sensitization by favoring the production of n-6 PUFA -derived inflammatory mediators.

In the second study (II), we showed that PUFA incorporation into phospholipids of infants was influenced by probiotics in infant formula in a strain dependent manner. It was observed that *Bifidobacterium lactis* Bb-12 present in infant formula promoted the utilization of n-3 PUFA. In so much as the clinical efficacy of probiotic formulas investigated here have been linked to functionality of probiotics, these results may indicate yet another mechanism by which the probiotics could alleviate the intestinal inflammation.

We also investigated the effects of PUFA on physicochemical properties of probiotics (III). In addition that we demonstrated that probiotics did incorporate exogenous free PUFA into bacterial fatty acids, our data also indicated that free PUFA in the growth medium of lactobacilli did induce PUFA interconversion reactions within bacterial fatty acids, strain and PUFA dependently. Despite these changes in cellular fatty acids, only minor alterations in hydrophobicity and electron donor – electron acceptor properties of lactobacilli were observed. Based on the findings of both Study II and III, it is suggested that the members of indigenous microbiota (such as probiotics) may readjust the PUFA milieu within the intestine and potentially influence the delicate balance of PUFA derived inflammatory mediators.

In the last study (IV), we demonstrated that high concentrations of free PUFA generally inhibit the growth and mucus adhesion of lactobacilli. However, low concentrations of specific long chain PUFA were found to promote the growth and mucus adhesion of lactobacilli (especially *L. casei* Shirota). In addition, free PUFA were also demonstrated to alter the adhesion capacity of the intestinal epithelial cells. In general, n-6 PUFA tended to inhibit the Caco-2 adhesion, whereas n-3 PUFA had minimal effects or even promoted the bacterial adhesion to Caco-2 cells (*L. casei* Shirota). The demonstrated PUFA-derived changes in functional properties of both probiotics and mucosal epithelia indicate that the health promoting effects of probiotics may be modulated by PUFA composition of probiotic end-product or general dietary PUFA consumption of an individual. Still, whether the shown clinical efficacy of the probiotic supplemented formulas (of the study II) is due to potentiated probiotics warrants further studies.

Even though both probiotics and PUFA have been previously shown to possess similar modes of actions in promoting health benefits, there is also number of studies with conflicting results. Beyond differences in populations and study designs, it is intriguing to hypothesize that the cause of variation in the outcomes of these studies may be partly elucidated based on the findings presented in this work. Although it is too early to give any guidelines based on the results presented here, we can propose that different production conditions such as growth media may affect the functional properties of different probiotic strains used by dairy industry. In addition, the composition of final end-products may also influence the availability and functionality of the probiotic, again in a strain dependent manner. In other words, even the most promising probiotic strain (according to *in vitro* / animal model characterisations) may be reported to possess mediocre health benefits in the clinical study setting only because the production process or used food matrix does not support the needs of that given strain. Contrary to the previous statement, less potential probiotics strains may show promising health benefits in a clinical study due in part to the production process and/or food matrix having potentiated the efficacy of the given strain. Subsequently, even though the basic characterisation is pivotal in finding new probiotic strains, more emphasis should be given to the design of actual end products prior to any major clinical trial. In general, the findings of this thesis suggest that better understanding of interactions between dietary factors, such as PUFA, and the members of intestinal microbiota is a prerequisite, when the beneficial effects of novel functional foods containing probiotics are designed and clinically assessed.

## 9 ACKNOWLEDGEMENTS

The studies presented in this thesis were carried out at the Department of Biochemistry and Food Chemistry and the Functional Food Forum, University of Turku, Finland as well at the Department of Medical Microbiology, National University of Singapore, Singapore.

I am grateful for the financial support provided by the Finnish Graduate School on “*Applied Bioscience: Bioengineering, Food & Nutrition, Environment*”. This work was further financially supported by the Technology Development Agency of Finland (TEKES) (I, III and IV), the Academy of Finland and Wäinö Edvard Miettinen Foundation (I), and Finnish Food Research Foundation (IV).

I express my deepest thanks to my supervisors Professor Seppo Salminen and Professor Erika Isolauri. Seppo has always had time for scientific discussions as well as has repeatedly offered me opportunities that could have never been realized without his continuous enthusiasm. Erika’s devotion, critical thinking and expertise in medical research have coached me throughout this study – and still do. Both Seppo and Erika are also thanked for providing me with the first-class facilities for carrying out these studies.

I thank the reviewers of this thesis, Professor Atte von Wright and PhD Ross Crittenden for their constructive and valuable criticisms and comments. I also owe my sincere thanks to PhD Jonathan Carmichael for his valuable comments and revision of English language of the thesis.

I am grateful to my coauthors, Professor Yuan Kun Lee, Professor Heikki Kallio, Docent Arja Erkkilä, MD Marko Kalliomäki, MD Doris Holmberg-Marttila, PhD Baoru Yang and MSc Kari Nurmela for the well-functioning collaboration. I further wish to acknowledge PhD Essi Sarkkinen for advising on interpretation of serum lipid fatty acid data, PhD Ulla Hoppu and MSc Leena Seppo for food record calculations in Study I, and the assistance of MD Taina Arvola in organizing the clinical samples (Study II). Special thanks are also due to Professor Glenn Gibson, PhD Arthur Ouwehand, PhD Ross Crittenden and FL Tuula Humphreys for their valuable comments and revision of English language of the publications.

I am indebted to Professor Yuan Kun Lee, Professor Wolfgang Kneifel and Docent Esa-Matti Lilius for giving me the opportunity to work in their laboratories. I will also thank PhD Jari Nuutila, PhD Baoru Yang and PhD Pirkka Kirjavainen for their technical assistance in the laboratory as well as for the enjoyable moments we have shared, and PhD Kaj Blomberg and MSc Satu Kovanen for their continuous support and encouragement in completing this PhD thesis over the time I've spent at PerkinElmer. My sincere thanks go to my colleagues and R&D personnel at the PerkinElmer as well.

My parents, Raija and Erik, and my sister I warmly thank for their infinite love, encouragement and inspiration throughout my life. I wish my Dad would have seen this 'hat'. The kindness and support of my parents-in-law Tuija and Veikko is also acknowledged.

Finally, I wish to my most loving thanks to my wife Outi for her endless patience, love and care. Our dear children Tinka and Daniel, by radiating unconditional love and endless joy you constantly prove us what is essential in life.

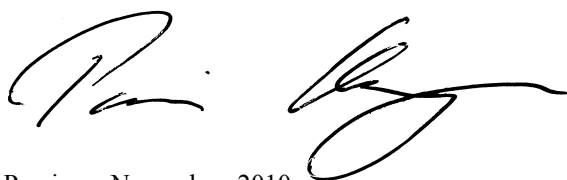
A handwritten signature in black ink, appearing to read 'Raija Parainen'. The signature is fluid and cursive, with a large initial 'R' and a long, sweeping underline.

Parainen, November, 2010



## 10 REFERENCES

- Abrahamsson TR, Jakobsson T, Böttcher MF, Fredrikson M, Jenmalm MC, Björkstén B, Oldaeus G** Probiotics in prevention of IgE-associated eczema: a double-blind, randomized, placebo-controlled trial. *J Allergy Clin Immunol.* 2007;**119**(5):1174-80
- Abrahamsson TR, Sinkiewicz G, Jakobsson T, Fredrikson M, Björkstén B** Probiotic lactobacilli in breast milk and infant stool in relation to oral intake during the first year of life. *J Pediatr Gastroenterol Nutr.* 2009;**49**(3):349-54
- Adlerberth I, Lindberg E, Aberg N, Hesselmar B, Saalman R, Strannegård IL, Wold AE** Reduced enterobacterial and increased staphylococcal colonization of the infantile bowel: an effect of hygienic lifestyle? *Pediatr Res.* 2006;**59**(1):96-101
- Agostoni C** Role of long-chain polyunsaturated fatty acids in the first year of life. *J Pediatr Gastroenterol Nutr.* 2008;**47** Suppl 2:S41-4
- Ahmadian M, Duncan RE, Sul HS** The skinny on fat: lipolysis and fatty acid utilization in adipocytes. *Trends Endocrinol Metab.* 2009;**20**(9):424-8
- Al-Turkmani MR, Freedman SD, Laposata M** Fatty acid alterations and n-3 fatty acid supplementation in cystic fibrosis. *Prostaglandins Leukot Essent Fatty Acids* 2007;**77**(5-6):309-18
- Baddini Feitoza A, Fernandes Pereira A, Ferreira da Costa N, Gonçalves Ribeiro B** Conjugated linoleic acid (CLA): effect modulation of body composition and lipid profile. *Nutr Hosp* 2009;**24**(4):422-8
- Baker SJ** Contribution of the microflora of the small intestine to the vitamin b12 nutriture of man. *Nutr Rev.* 1981;**39**(3):147-8.
- Belluzzi A, Brignola C, Campieri M, Pera A, Boschi S, Miglioli M** Effect of an enteric-coated fish-oil preparation on relapses in Crohn's disease. *N Engl J Med.* 1996;**334**(24):1557-60
- Bennet R, Nord CE** Development of the faecal anaerobic microflora after caesarean section and treatment with antibiotics in newborn infants. *Infection.* 1987;**15**(5):332-6
- Bennet R, Eriksson M, Nord CE** The fecal microflora of 1-3-month-old infants during treatment with eight oral antibiotics. *Infection.* 2002;**30**(3):158-60
- Benno Y, Sawada K, Mitsuoka T** The intestinal microflora of infants: composition of fecal flora in breast-fed and bottle-fed infants. *Microbiol Immunol.* 1984;**28**(9):975-86
- Benno Y and Mitsuoka T** Development of intestinal microflora in humans and animals. *Bifidobacteria Microflora* 1986;**5**:13-25
- Biltagi MA, Baset AA, Bassiouny M, Kasrawi MA, Attia M** Omega-3 fatty acids, vitamin C and Zn supplementation in asthmatic children: a randomized self-controlled study. *Acta Paediatr.* 2009;**98**(4):737-42.
- Birch EE, Hoffman DR, Uauy R, Birch DG, Prestidge C** Visual acuity and the essentiality of docosahexaenoic acid and arachidonic acid in the diet of term infants. *Pediatr Res* 1998;**44**:201-209
- Bomba A, Nemcová R, Mudronová D and Guba P** The possibilities of potentiating the efficacy of probiotics. *Trends Food Sci* 2002a;**13**:121-126
- Bomba A, Nemcová R, Gancarciková S, Herich R, Guba P, Mudronová D** Improvement of the probiotic effect of micro-organisms by their combination with maltodextrins, fructo-oligosaccharides and polyunsaturated fatty acids. *Br J Nutr.* 2002b;**88** Suppl 1:S95-9
- Borgström B, Donnér J** The polar interactions between pancreatic lipase, colipase and the triglyceride substrate. *FEBS Lett.* 1977;**83**(1):23-6
- Bourre JM, Bonneil M, Dumont O, Piciotti M, Nalbone G, Lafont H** High dietary fish oil alters the brain polyunsaturated fatty acid composition. *Biochim Biophys Acta.* 1988;**960**:458-461
- Bourre JM, Dumont O, Piciotti M, Pascal G, Durand G** Composition of nerve biomembranes and nutritional fatty acids. *Nutr* 1989;**5**:266-270
- Boyle RJ, Bath-Hextall FJ, Leonardi-Bee J, Murrell DF, Tang ML** Probiotics for the treatment of eczema: a systematic review. *Clin Exp Allergy.* 2009;**39**(8):1117-27

- Black PN and Sharpe S.** Dietary fat and asthma: is there a connection? *Eur. Respir. J.* 1997;**10**:6-12
- Brenna JT, Salem N Jr, Sinclair AJ, Cunnane SC** alpha-Linolenic acid supplementation and conversion to n-3 long-chain polyunsaturated fatty acids in humans. *Prostaglandins Leukot Essent Fatty Acids* 2009;**80**(2-3):85-91
- Brenner RR** Regulatory function of delta6 desaturase -- key enzyme of polyunsaturated fatty acid synthesis. *Adv Exp Med Biol.* 1977;**83**:85-101
- Briandet R, Meylheuc T, Maher C and Bellon-Fontaine M.N,** *Listeria monocytogenes* Scott A: Cell Surface Charge, Hydrophobicity, and Electron Donor and Acceptor Characteristics under Different Environmental Growth Conditions, *Appl. Environmental. Microbiol.*1999;**65**:5328-5333
- Brigidi P, Vitali B, Swennen E, Bazzocchi G, Matteuzzi D** Effects of probiotic administration upon the composition and enzymatic activity of human fecal microbiota in patients with irritable bowel syndrome or functional diarrhea. *Res Microbiol.* 2001;**152**(8):735-41
- Brink C, Dahlen SE, Drazen J, Evans JF, Hay DW, Nicosia S, Serhan CN, Shimizu T, Yokomizo T** International Union of Pharmacology XXXVII. Nomenclature for leukotriene and lipoxin receptors. *Pharmacol Rev* 2003;**55**:195-227
- Burt S** Essential oils: their antibacterial properties and potential applications in foods--a review. *Int J Food Microbiol.* 2004;**94**(3):223-53
- Businco L, Loppi M, Morse NL, Nisini R, Wright S** Breast milk from mothers of children with newly developed atopic eczema has low levels of long chain polyunsaturated fatty acids. *J Allergy Clin Immunol* 1993;**91**:1134-1139
- Calder PC** Fat chance of immunomodulation. *Immunol Today* 1998;**19**:244-247
- Calder PC** Polyunsaturated fatty acids, inflammation, and immunity. *Lipids* 2001;**36**:1007-1024
- Calder PC** n-3 polyunsaturated fatty acids, inflammation and inflammatory diseases. *Am J Clin Nutr* 2006;**83**(suppl):1505S-1519S
- Calder PC** Abnormal fatty acid profiles occur in atopic dermatitis but what do they mean? *Clin Exp Allergy* 2006b;**36**:138-141
- Calder PC** Polyunsaturated fatty acids, inflammatory processes and inflammatory bowel diseases. *Mol Nutr Food Res.* 2008;**52**(8):885-97
- Canani PD and Delzenne NM** The role of the gut microbiota in energy metabolism and metabolic disease. *Curr Pharm Des.* 2009;**15**(13):1546-58
- Carlson SE, Cooke RJ, Werkman SH, Tolley EA** First year growth of preterm infants fed standard compared to marine oil n-3 supplemented formula. *Lipids* 1992;**27**:901-907
- Castuma JC, Brenner RR, Kunau W** Specificity of delta 6 desaturase--effect of chain length and number of double bonds. *Adv Exp Med Biol.* 1977;**83**:127-34
- Chambon M,** Milk Fat. In: *Oil and Fats Manual* (Karleskind, A. ed.), Vol. 1; 1996;pp.277-286. Lavoisier Publishing, France
- Chan SC, Kim JW, Henderson WR Jr, Hanifin JM** Altered prostaglandin E2 regulation of cytokine production in atopic dermatitis. *J Immunol.* 1993;**151**(6):3345-52
- Cho HP, Nakamura MT, Clarke SD** Cloning, expression, and nutritional regulation of the mammalian Delta-6 desaturase. *J Biol Chem.* 1999;**274**(1):471-7
- Christie WW,** A Simple Procedure for Rapid Transmethylation of Glycerolipids and Cholesteryl Esters, *J. Lipid Res.* 1982;**23**:1072-1075
- Clandinin MT, Jumpsen J, Suh M** Relationship between fatty acid accretion, membrane composition, and biologic functions. *J Pediatr.* 1994;**125**(5 Pt 2):S25-32
- Ciprandi G, Vizzaccaro A, Cirillo I, Tosca MA** *Bacillus clausii* exerts immuno-modulatory activity in allergic subjects: a pilot study. *Eur Ann Allergy Clin Immunol.* 2005;**37**(4):129-34
- Collado MC, Delgado S, Maldonado A, Rodríguez JM** Assessment of the bacterial diversity of breast milk of healthy women by quantitative real-time PCR. *Lett Appl Microbiol.* 2009;**48**(5):523-8

- Crittenden RG and Bennett LE** Cow's Milk Allergy: A Complex Disorder. *J Am Col Nutr* 2005;24 (No. 90006):582S-591S
- Cross ML, Stevenson LM, Gill HS** Anti-allergy properties of fermented foods: an important immunoregulatory mechanism of lactic acid bacteria? *Int Immunopharmacol*. 2001;1(5):891-901
- Cui HH, Chen CL, Wang JD, Yang YJ, Cun Y, Wu JB, Liu YH, Dan HL, Jian YT, Chen XQ** Effects of probiotic on intestinal mucosa of patients with ulcerative colitis. *World J Gastroenterol* 2004;10(10):1521-5
- Culligan EP, Hill C, Sleator RD** Probiotics and gastrointestinal disease: successes, problems and future prospects. *Gut Pathog*. 2009;1(1):19
- Cummings JH** Dietary carbohydrates and the colonic microflora. *Curr Opin Clin Nutr Metab Care*. 1998;1(5):409-14
- Cummings JH, Macfarlane GT, Englyst HN** Prebiotic digestion and fermentation. *Am J Clin Nutr*. 2001;73(2 Suppl):415S-420S
- Dawczynski C, Schubert R, Hein G, Müller A, Eidner T, Vogelsang H, Basu S, Jahreis G** Long-term moderate intervention with n-3 long-chain PUFA-supplemented dairy products: effects on pathophysiological biomarkers in patients with rheumatoid arthritis. *Br J Nutr*. 2009;101(10):1517-26
- Dambekodi PC, Gilliland SE** Incorporation of cholesterol into the cellular membrane of *Bifidobacterium longum*. *J Dairy Sci*. 1998;81(7):1818-24
- Das UN** Essential fatty acids as possible enhancers of the beneficial actions of probiotics. *Nutr* 2002;18:786-789
- De Caterina R and Libby P** Control of endothelial leukocyte adhesion molecules by fatty acids. *Lipids* 1996;31:S57-S63
- De Simone C, Vesely R, Negri R, Bianchi Salvadori B, Zanzoglu S, Cilli A, Lucci L** Enhancement of immune response of murine Peyer's patches by a diet supplemented with yogurt. *Immunopharmacol Immunotoxicol*. 1987;9(1):87-100
- de Vrese M, Schrezenmeir J** Probiotics, prebiotics, and synbiotics. *Adv Biochem Eng Biotechnol*. 2008;111:1-66
- Delarue J, LeFoll C, Corporeau C, Lucas D** N-3 long chain polyunsaturated fatty acids: a nutritional tool to prevent insulin resistance associated to type 2 diabetes and obesity? *Reprod Nutr Dev*. 2004;44(3):289-99
- Demmelmair H, Baumheuer M, Koletzko B, Dokoupil K, Kratl G.** Investigation of long-chain polyunsaturated fatty acid metabolism in lactating women by means of stable isotope techniques. *Adv Exp Med Biol*. 2001;501:169-77
- Denburg JA, Hatfield HM, Cyr MM, Hayes L, Holt PG, Sehmi R, Dunstan JA, Prescott SL** Fish oil supplementation in pregnancy modifies neonatal progenitors at birth in infants at risk of atopy. *Pediatr Res*. 2005;57(2):276-81
- Dignass AU, Baumgart DC, Sturm A** Review article: the aetiopathogenesis of inflammatory bowel disease--immunology and repair mechanisms. *Aliment Pharmacol Ther*. 2004;20 Suppl 4:9-17
- Dionisi F, Golay P-A, Elli M and Fay LB** Stability of Cyclopropane and Conjugated Linoleic Acids during Fatty Acid Quantification in Lactic Acid Bacteria. *Lipids* 1999;34:1107-1115
- Donnet-Hughes A, Rochat F, Serrant P, Aeschlimann JM, Schiffrin EJ** Modulation of nonspecific mechanisms of defense by lactic acid bacteria: effective dose. *J Dairy Sci*. 1999;82(5):863-9
- D'Souza AL, Rajkumar C, Cooke J, Bulpitt CJ** Probiotics in prevention of antibiotic associated diarrhoea: meta-analysis. *BMJ*. 2002;324(7350):1361
- Dubey AP, Rajeshwari K, Chakravarty A, Famularo G** Use of VSL[sharp]3 in the treatment of rotavirus diarrhea in children: preliminary results. *J Clin Gastroenterol*. 2008;42 Suppl 3 Pt 1:S126-9
- Duchen K, Yu G, Björkstén B** Atopic sensitization during the first year of life in relation to long chain polyunsaturated fatty acid levels in human milk. *Pediatr Res* 1998;44:478-484
- Duchén K, Yu G, Björkstén B** Polyunsaturated fatty acids in breast milk in relation to atopy in the mother and her child. *Int Arch Allergy Immunol*. 1999;118(2-4):321-3
- Duncan JM and Sears MR** Breastfeeding and allergies: time for a change in paradigm? *Curr Opin Allergy Clin Immunol*. 2008;8(5):398-405

- Dunder T, Kuikka L, Turtinen J, Räsänen L, Uhari M** Diet, serum fatty acids, and atopic diseases in childhood. *Allergy*. 2001;**56**(5):425-8.
- Dunstan JA, Mori TA, Barden A, Beilin LJ, Taylor AL, Holt PG, Prescott SL** Fish oil supplementation in pregnancy modifies neonatal allergen-specific immune responses and clinical outcomes in infants at high risk of atopy: a randomized, controlled trial. *J Allergy Clin Immunol*. 2003;**112**(6):1178-84
- Eamonn PC, Hill C and Sleator RD** Probiotics and gastrointestinal disease: successes, problems and future prospects. *Gut Pathog*. 2009; **1**:19
- El-Nezami H, Kankaanpää P, Salminen S, Ahokas J** Ability of dairy strains of lactic acid bacteria to bind a common food carcinogen, aflatoxin B1. *Food Chem Toxicol*. 1998;**36**(4):321-6
- Endres S** Messengers and mediators: Interactions among lipids, eicosanoids and cytokines. *Am J Clin Nutr* 1993;**57**:S798-S800
- Engelbrecht AM, Toit-Kohn JL, Ellis B, Thomas M, Nell T, Smith R** Differential induction of apoptosis and inhibition of the PI3-kinase pathway by saturated, monounsaturated and polyunsaturated fatty acids in a colon cancer cell model. *Apoptosis* 2008;**13**(11):1368-77
- Erkkilä AT, Sarkkinen ES, Koukkunen H, Kempainen A, Lehto S, Pyörälä K, Uusitupa M,** Concordance of diet with the recommended cholesterol lowering diet in patients with coronary heart disease. *Eur J Clin Nutr* 1998;**52**:279-285
- Fanaro S, Chierici R, Guerrini P, Vigi V** Intestinal microflora in early infancy: composition and development. *Acta Paediatr Suppl*. 2003;**91**(441):48-55
- Fanaro S, Vigi V** Which role for prebiotics at weaning? *J Clin Gastroenterol*. 2008;**42** Suppl 3 Pt 2:S209-13
- FAO/WHO Joint Working Group** Report on Drafting Guidelines for the Evaluation of Probiotics in Food. London, Ontario, Canada, April 30 and May 1, 2002
- FAO/WHO.** Report of a Joint FAO/WHO Expert Consultation on Evaluation of Health and Nutritional Properties of Probiotics in Food Including Powder Milk with Lactic Acid Bacteria (October 2001). Food and Agriculture Organisation of the United Nations, World Health Organization. Retrieved 2009
- Favier CF, Vaughan EE, De Vos WM, Akkermans AD** Molecular monitoring of succession of bacterial communities in human neonates. *Appl Environ Microbiol*. 2002;**68**(1):219-26
- Federation Internatinnale de Laiterie-International Dairy Federation** Determination of fat. 1987;**1C**:1-8
- Finley DA, Lönnerdal B, Dewey KG, Grivetti LE** Breast milk composition: fat content and fatty acid composition in vegetarians and non-vegetarians. *Am J Clin Nutr*. 1985;**41**(4):787-800
- Floch MH, Walker WA, Guandalini S, Hibberd P, Gorbach S, Surawicz C, Sanders ME, Garcia-Tsao G, Quigley EM, Isolauri E, Fedorak RN, Dieleman LA** Recommendations for probiotic use--2008. *J Clin Gastroenterol*. 2008;**42** Suppl 2:S104-8
- Focke M, Sesztak-Greinecker G, Brannath W, Götz M, Jarisch R, Hemmer W** Plasma levels of polyunsaturated fatty acids in children with atopic dermatitis and in atopic and nonatopic controls. *Wien Klin Wochenschr*. 2005;**117**(13-14):485-91
- Folch J, Lees M, and Sloane-Stanley GH,** A simple method for the isolation and purification of total lipids from animal tissues. *J. Biol. Chem*. 1957;**226**:497-509
- Forman BM, Chen J, Evans RM** The peroxisome proliferator-activated receptors: ligands and activators. *Ann N Y Acad Sci*. 1996;**804**:266-75
- Francois CA, Connor SL, Wander RC, Connor WE** Acute effects of dietary fatty acids on the fatty acids of human milk. *Am J Clin Nutr*. 1998;**67**(2):301-8
- Fuller R and Gibson GR** Modification of the intestinal microflora using probiotics and prebiotics. *Scand J Gastroenterol Suppl*. 1997;**222**:28-31
- Funk CD** Prostaglandins and leukotrienes: advances in eicosanoid biology. *Science* 2001;**294**:1871-1875
- Furuhjelm C, Warstedt K, Larsson J, Fredriksson M, Böttcher MF, Fälth-Magnusson K, Duchén K** Fish oil supplementation in pregnancy and lactation may decrease the risk of infant allergy. *Acta Paediatr*. 2009;**98**(9):1461-7

- Ghadimi D, Fölster-Holst R, de Vrese M, Winkler P, Heller KJ, Schrezenmeir J** Effects of probiotic bacteria and their genomic DNA on TH1/TH2-cytokine production by peripheral blood mononuclear cells (PBMCs) of healthy and allergic subjects. *Immunobiol* 2008;**213**(8):677-92
- Gibson RA, Barclay D, Marshall H, Moulin J, Maire JC, Makrides M** Safety of supplementing infant formula with long-chain polyunsaturated fatty acids and Bifidobacterium lactis in term infants: a randomised controlled trial. *Br J Nutr*. 2009;**101**(11):1706-13
- Gionchetti P, Rizzello F, Venturi A, Brigidi P, Matteuzzi D, Bazzocchi G, Poggioli G, Miglioli M, Campieri M** Oral bacteriotherapy as maintenance treatment in patients with chronic pouchitis: a double-blind, placebo-controlled trial. *Gastroenterol*. 2000;**119**(2):305-9
- Goldin BR, Gorbach SL, Saxelin M, Barakat S, Gualtieri L and Salminen S** Survival of *Lactobacillus* species (strain GG) in human gastrointestinal tract. *Dig. Dis. Sci*. 1992;**37**:121-128
- Gomez Zavaglia A, Disalvo EA & de Antoni GL** Fatty Acid Composition and Freeze-thaw Resistance in Lactobacilli. *J. Dairy Res.*2000;**67**:241-247
- Greene JD and Klaenhammer TR** Factors involved in adherence of lactobacilli to human Caco-2 cells. *Appl Environ Microbiol*. 1994;**60**(12):4487-94
- Grill JP, Cayuela C, Antoine JM, Schneider F** Effects of *Lactobacillus amylovorus* and *Bifidobacterium breve* on cholesterol. *Lett Appl Microbiol*. 2000;**31**(2):154-6
- Gronert K, Clish CB, Romano M, Serhan CN** Transcellular regulation of eicosanoid biosynthesis. *Methods Mol Biol* 1999;**120**:119-144
- Grönlund MM, Lehtonen OP, Eerola E, Kero P** Fecal microflora in healthy infants born by different methods of delivery: permanent changes in intestinal flora after cesarean delivery. *J Pediatr Gastroenterol Nutr*. 1999;**28**(1):19-25
- Grönlund MM, Arvilommi H, Kero P, Lehtonen OP, Isolauri E** Importance of intestinal colonisation in the maturation of humoral immunity in early infancy: a prospective follow up study of healthy infants aged 0-6 months. *Arch Dis Child Fetal Neonatal Ed*. 2000;**83**(3):F186-92
- Guandalini S, Pensabene L, Zikri MA, Dias JA, Casali LG, Hoekstra H, Kolacek S, Massar K, Micetic-Turk D, Papadopoulou A, de Sousa JS, Sandhu B, Szajewska H, Weizman Z** Lactobacillus GG administered in oral rehydration solution to children with acute diarrhea: a multicenter European trial. *J Pediatr Gastroenterol Nutr*. 2000;**30**(1):54-60
- Guandalini S** Probiotics for children with diarrhea: an update. *J Clin Gastroenterol*. 2008;**42** Suppl 2:S53-7
- Gueimonde M, Kalliomäki M, Isolauri E, Salminen S** Probiotic intervention in neonates--will permanent colonization ensue? *J Pediatr Gastroenterol Nutr*. 2006;**42**(5):604-6
- Guertzoni ME, Lanciotti R, Cocconcelli PS** Alteration in cellular fatty acid composition as a response to salt, acid, oxidative and thermal stresses in *Lactobacillus helveticus*. *Microbiol* 2001;**147**(Pt 8):2255-64
- Gupta P, Andrew H, Kirschner BS, Guandalini S** Is lactobacillus GG helpful in children with Crohn's disease? Results of a preliminary, open-label study. *J Pediatr Gastroenterol Nutr*. 2000;**31**(4):453-7
- Gupta RA, Tan J, Krause WF, Geraci MW, Willson TM, Dey SK, DuBois RN** Prostacyclin-mediated activation of peroxisome proliferator-activated receptor delta in colorectal cancer *Proc Natl Acad Sci U S A*. 2000;**97**(24):13275-13280
- Gusils C, Cuzzo S, Sesma F & Gonzalez S** Examination of adhesive determinants in three species of *Lactobacillus* isolated from chicken. *Can. J. Microbiol*. 2002;**48**:34-42
- Halpern GM, Prindiville T, Blankenburg M, Hsia T, Gershwin ME** Treatment of irritable bowel syndrome with Lacteol Fort: a randomized, double-blind, cross-over trial. *Am J Gastroenterol*. 1996;**91**(8):1579-85
- Halttunen T, Collado MC, El-Nezami H, Meriluoto J, Salminen S** Combining strains of lactic acid bacteria may reduce their toxin and heavy metal removal efficiency from aqueous solution. *Lett Appl Microbiol*. 2008;**46**(2):160-5
- Hamosh M** A review. Fat digestion in the newborn: role of lingual lipase and preduodenal digestion. *Pediatr Res*. 1979;**13**(5 Pt 1):615-22
- Hanifin JM**, Epidemiology of atopic dermatitis. *Monogr Allergy* 1987;**21**:116-131

- Hanifin JM**, Atopic dermatitis in children. *Pediatr. Clin. N. Am.* 1991;**38**:763-789
- Hanifin JM** Atopiform dermatitis: do we need another confusing name for atopic dermatitis *Br J Dermatol* 2002;**147**:40-432
- Harmsen HJ, Wildeboer-Veloo AC, Raangs GC, Wagendorp AA, Klijn N, Bindels JG, Welling GW** Analysis of intestinal flora development in breast-fed and formula-fed infants by using molecular identification and detection methods. *J Pediatr Gastroenterol Nutr.* 2000;**30**(1):61-7
- Hatakka K, Savilahti E, Pönkä A, Meurman JH, Poussa T, Näse L, Saxelin M, Korpela R** Effect of long term consumption of probiotic milk on infections in children attending day care centres: double blind, randomised trial. *BMJ.* 2001;**322**(7298):1327
- Hatakka K, Holma R, El-Nezami H, Suomalainen T, Kuisma M, Saxelin M, Poussa T, Mykkänen H, Korpela R** The influence of *Lactobacillus rhamnosus* LC705 together with *Propionibacterium freudenreichii* ssp. *shermanii* JS on potentially carcinogenic bacterial activity in human colon. *Int J Food Microbiol.* 2008;**128**(2):406-10
- He F, Morita H, Kubota A, Ouwehand AC, Hosoda M, Hiramatsu M, Kurisaki J** Effect of orally administered non-viable *Lactobacillus* cells on murine humoral immune responses. *Microbiol Immunol.* 2005;**49**(11):993-7
- Hekmatdoost A, Feizabadi MM, Djazayeri A, Mirshafiey A, Eshraghian MR, Yeganeh SM, Sedaghat R, Jacobson K** The effect of dietary oils on cecal microflora in experimental colitis in mice. *Indian J Gastroenterol.* 2008;**27**(5):186-9
- Healy DA, Wallace FA, Miles EA, Calder PC, Newsholm P** The effect of low-to-moderate amounts of dietary fish oil on neutrophil lipid composition and function. *Lipids* 2000;**35**:763-768
- Helin T, Haahntela S and Haahntela T** No effect of oral treatment with an intestinal bacterial strain, *Lctobacillus rhamnosus* (ATCC 53103), on birch-pollen allergy: a placebo-controlled double-blind study. *Allergy* 2002;**57**:243-246
- Hilton E, Kolakowski P, Singer C, Smith M** Efficacy of *Lactobacillus* GG as a Diarrheal Preventive in Travelers. *J Travel Med.* 1997;**4**(1):41-43
- Hiltunen JK, Filppula SA, Koivuranta KT, Siivari K, Qin YM, Häyrynen HM** Peroxisomal beta-oxidation and polyunsaturated fatty acids. *Ann N Y Acad Sci.* 1996;**804**:116-28
- Hodge L, Salome CM, Peat JK, Haby MM, Xuan W, Woolcock AJ** Consumption of oily fish and childhood asthma risk. *Med J Aust.* 1996;**164**(3):137-40.
- Hoffman DR, Boettcher JA, Diersen-Schade DA** Toward optimizing vision and cognition in term infants by dietary docosahexaenoic and arachidonic acid supplementation: a review of randomized controlled trials. *Prostaglandins Leukot Essent Fatty Acids.* 2009;**81**(2-3):151-158
- Hornstra G** Essential fatty acids in mothers and their neonates. *Am J Clin Nutr.* 2000;**71**(5 Suppl):1262S-1269S
- Hoppu U, Kalliomäki M, Isolauri E.** Maternal diet rich in saturated fat during breastfeeding is associated with atopic sensitization of the infant. *Eur J Clin Nutr* 2000;**54**:702-705
- Hoppu U, Rinne M, Lampi AM, Isolauri E** Breast milk fatty acid composition is associated with development of atopic dermatitis in the infant. *J Pediatr Gastroenterol Nutr.* 2005;**41**(3):335-8
- Husni RN, Gordon SM, Washington JA, Longworth DL** *Lactobacillus* bacteremia and endocarditis: review of 45 cases. *Clin Infect Dis.* 1997;**25**(5):1048-55
- Hällström M, Eerola E, Vuento R, Janas M, Tammela O** Effects of mode of delivery and necrotising enterocolitis on the intestinal microflora in preterm infants. *Eur J Clin Microbiol Infect Dis.* 2004;**23**(6):463-70
- Innis SM.** Essential fatty acid transfer and fetal development. *Placenta.* 2005;**26** Suppl A:S70-5
- Innis SM and Jacobson K.** Dietary lipids in early development and intestinal inflammatory disease. *Nutr Rev.* 2007;**65**(12 Pt 2):S188-93
- ISAAC,** The International Study of Asthma and Allergies in Childhood (ISAAC) Steering Committee. Worldwide variation in prevalence of symptoms of asthma, allergic rhinoconjunctivitis, and atopic eczema. *Lancet* 1998;**351**:1225-1232

- Ishibashi N, Yamazaki S** Probiotics and safety. *Am J Clin Nutr.* 2001;**73**(2 Suppl):465S-470S
- Ishii KJ, Koyama S, Nakagawa A, Coban C, Akira S** Host innate immune receptors and beyond: making sense of microbial infections. *Cell Host Microbe.* 2008;**3**(6):352-63
- Isolauri E, Juntunen M, Rautanen T, Sillanaukee P and Koivula T** A human *Lactobacillus* strain (*Lactobacillus* GG) promotes recovery from acute diarrhea in children. *Pediatrics* 1989;**88**:90-97
- Isolauri E, Kaila M, Arvola T, Majamaa H, Rantala I, Virtanen E, Arvilommi H** Diet during rotavirus enteritis affects jejunal permeability to macromolecules in suckling rats. *Pediatr Res.* 1993;**33**(6):548-53
- Isolauri E, Majamaa H, Arvola T, Rantala I, Virtanen E, Arvilommi H** *Lactobacillus casei* strain GG reverses increased intestinal permeability induced by cow milk in suckling rats. *Gastroenterology.* 1993b;**105**(6):1643-50
- Isolauri E, Kaila M, Mykkänen H, Ling WH, Salminen S** Oral bacteriotherapy for viral gastroenteritis. *Dig Dis Sci.* 1993;**39**(12):2595-600
- Isolauri E, Pelto L, Nuutila J, Majamaa H, Lilius EM, Salminen S** Altered expression of IgG and complement receptors indicates a significant role of phagocytes in atopic dermatitis. *J Allergy Clin Immunol.* 1997;**99**(5):707-13
- Isolauri E, Tahvanainen A, Peltola T and Arvola T,** Breast-feeding of allergic infants. *J Pediatr* 1999;**134**:27-32
- Isolauri E, Arvola T, Sütas Y, Moilanen E, Salminen S** Probiotics in the management of atopic eczema. *Clin Exp Allergy.* 2000;**30**(11):1604-10
- Isolauri E, Sütas Y, Kankaanpää P, Arvilommi H, Salminen S** Probiotics: effects on immunity. *Am J Clin Nutr.* 2001;**73**(2 Suppl):444S-450S
- Isolauri E, Salminen S, Ouwehand AC** Microbial-gut interactions in health and disease. Probiotics. *Best Pract Res Clin Gastroenterol.* 2004;**18**(2):299-313
- Isolauri E and Salminen S,** Probiotics: Use in allergic disorders. A Nutrition, Allergy, Mucosal Immunology, and Intestinal Microbiota (NAMI) Research Group Report. *J. Clin. Gastroenterol.* 2008;**42**:S91-S96
- Jacobsson PJ, Thoren S, Morgenstern R, and Samuelsson B** Identification of human prostaglandin E synthase: a microsomal, glutathione-dependent, inducible enzyme, constituting a potential novel drug target. *Proc Natl Acad Sci U.S.A.* 1999;**96**(13):7220-7225
- Jenkins JK, Courtney PD** *Lactobacillus* growth and membrane composition in the presence of linoleic or conjugated linoleic acid. *Can J Microbiol.* 2003;**49**(1):51-7
- Jensen RG** Lipids in Human milk. *Lipids* 1999;**34**:1243-1271
- Jiang J, Björck L, Fonden R.** Production of conjugated linoleic acid by dairy starter cultures. *J Appl Microbiol.* 1998;**5**(1):95-102
- Johnsson T, Nikkilä P, Toivonen L, Rosenqvist H & Laakso S** Cellular Fatty Acid Profiles of *Lactobacillus* and *Lactococcus* Strains in Relation to Oleic Acid Content of The Cultivation Medium. *Appl Environ Microbiol* 1995;**61**:4497-4499
- Kabara JJ, Swieczkowski, DM, Conley AJ and Truant JP,** Fatty acids and derivatives as antimicrobial agents. *Antimicrob. Agents Chemother.* 1972;**2**:23-28
- Kaila M, Salo MK and Isolauri E,** Fatty acids in substitute formulas for cow's milk allergy. *Allergy* 1999;**54**:74-77
- Kalliomäki M, Kirjavainen P, Eerola E, Kero P, Salminen S, Isolauri E** Distinct patterns of neonatal gut microflora in infants in whom atopy was and was not developing. *J Allergy Clin Immunol.* 2001;**107**(1):129-34
- Kalliomäki M, Salminen S, Arvilommi H, Kero P, Koskinen P, Isolauri E** Probiotics in primary prevention of atopic disease: a randomised placebo-controlled trial. *Lancet* 2001b;**357**(9262):1076-9
- Kalliomäki M, Salminen S, Poussa T, Arvilommi H, Isolauri E** Probiotics and prevention of atopic disease: 4-year follow-up of a randomised placebo-controlled trial. *Lancet* 2003;**361**(9372):1869-71
- Kalliomäki M, Salminen S, Poussa T, Isolauri E** Probiotics during the first 7 years of life: a cumulative risk reduction of eczema in a randomized, placebo-controlled trial. *J Allergy Clin Immunol.* 2007;**119**(4):1019-21

- Kamlage B, Hartmann L, Gruhl B, and Blaut M** Intestinal microorganisms do not supply associated gnotobiotic rats with conjugated linoleic acid. *J Nutr* 1999;**129**:2212-2217
- Kamlage B, Hartmann L, Gruhl B, and Blaut M** Linoleic acid conjugation by human intestinal microorganisms is inhibited by glucose and other substrates in vitro and in gnotobiotic rats. *J Nutr* 2000;**130**:2036-2039
- Kankaanpää P, Sutas Y, Salminen S and Isolauri E** Dietary fatty acids and allergy. *Ann Med* 1999;**31**:282-287
- Kankaanpää P, Tuomola E, El-Nezami H, Ahokas J, Salminen SJ** Binding of aflatoxin B1 alters the adhesion properties of *Lactobacillus rhamnosus* strain GG in a Caco-2 model. *J Food Prot.* 2000;**63**(3):412-4
- Kankaanpää P, Sutas Y, Salminen S and Isolauri E** Homogenates derived from probiotic bacteria provide down-regulatory signals for peripheral blood mononuclear cells. *Food Chem* 2003;**83**:269-277
- Kankainen M, Paulin L, Tynkkynen S, von Ossowski I, Reunanen J, Partanen P, Satokari R, Vesterlund S, Hendrickx AP, Lebeer S, De Keersmaecker SC, Vanderleyden J, Hämäläinen T, Laukkanen S, Salovuori N, Ritari J, Alatalo E, Korpela R, Mattila-Sandholm T, Lassig A, Hatakka K, Kinnunen KT, Karjalainen H, Saxelin M, Laakso K, Surakka A, Palva A, Salusjärvi T, Auvinen P, de Vos WM** Comparative genomic analysis of *Lactobacillus rhamnosus* GG reveals pili containing a human- mucus binding protein. *Proc Natl Acad Sci U S A.* 2009;**106**(40):17193-8
- Kaplan N, Isolauri E, Lampi AM, Ojala T, Laitinen K.** Dietary counseling and probiotic supplementation during pregnancy modify placental phospholipid fatty acids. *Lipids.* 2007;**42**(9):865-70
- Kirjavainen PV, Ouwehand AC, Isolauri E and Salminen SJ,** The ability of probiotic bacteria to bind to human intestinal mucus. *FEMS Microbiol. Lett.* 1998;**167**:185-189
- Kirjavainen PV, El-Nezami HS, Salminen SJ, Ahokas JT, Wright PF** The effect of orally administered viable probiotic and dairy lactobacilli on mouse lymphocyte proliferation. *FEMS Immunol Med Microbiol.* 1999;**26**(2):131-5
- Kirjavainen PV, ElNezami HS, Salminen SJ, Ahokas JT, Wright PF** Effects of orally administered viable *Lactobacillus rhamnosus* GG and *Propionibacterium freudenreichii* subsp. *shermanii* JS on mouse lymphocyte proliferation. *Clin Diagn Lab Immunol.* 1999b;**6**(6):799-802
- Kodicek E and Worden AN,** The effect of unsaturated fatty acids on *Lactobacillus helveticus* and other Gram-positive micro-organisms. *Biochem. J.* 1945;**39**:78-82
- Kohn G, Sawatzki G, van Biervliet JP** Rosseneu M. Diet and the essential fatty acid status of term infants. *Acta Paediatr Suppl.* 1994;**402**:69-74
- Koletzko B Thiel I, Abiodun PO** The fatty acid composition of human milk in Europe and Africa. *J Pediatr* 1992;**120**:62-70
- Koletzko B** Fats for brains. *Eur J Clin Nutr,* 1992b;**46**:S51-S62
- Koletzko B and Rodriguez-Palmero M** Polyunsaturated fatty acids in human milk and their role in early infant development. *J Mammary Gland Biol and Neoplasia* 1999;**4**(3):269-284
- Koletzko B, Rodriguez-Palmero M, Demmelmair H, Fidler N, Jensen R, Sauerwald T** Physiological aspects of human milk lipids. *Early Hum Dev.* 2001;**65**:S3-S18
- Koletzko B, Lien E, Agostoni C, Böhles H, Campoy C, Cetin I, Decsi T, Dudenhausen JW, Dupont C, Forsyth S, Hoesli I, Holzgreve W, Lapillonne A, Putet G, Secher NJ, Symonds M, Szajewska H, Willatts P, Uauy R; World Association of Perinatal Medicine Dietary Guidelines Working Group** The roles of long-chain polyunsaturated fatty acids in pregnancy, lactation and infancy: review of current knowledge and consensus recommendations. *J Perinat Med.* 2008;**36**(1):5-14
- Kopp MV, Hennemuth I, Heinzmann A, Urbanek R.** Randomized, double-blind, placebo-controlled trial of probiotics for primary prevention: no clinical effects of *Lactobacillus* GG supplementation. *Pediatrics.* 2008;**121**(4):850-6.
- Krauss-Etschmann S, Shadid R, Campoy C, Hoster E, Demmelmair H, Jiménez M, Gil A, Rivero M, Veszprémi B, Decsi T, Koletzko BV; Nutrition and Health Lifestyle (NUHEAL) Study Group** Effects of fish-oil and folate supplementation of pregnant women on maternal and fetal plasma concentrations of docosahexaenoic acid and eicosapentaenoic acid: a European randomized multicenter trial. *Am J Clin Nutr.* 2007;**85**(5):1392-400



- Kremmyda LS, Vlachava M, Noakes PS, Diaper ND, Miles EA, Calder PC** Atopy Risk in Infants and Children in Relation to Early Exposure to Fish, Oily Fish, or Long-Chain Omega-3 Fatty Acids: A Systematic Review. *Clin Rev Allergy Immunol*. 2009 Dec 9. [Epub ahead of print]
- Laitinen K, Hoppu U, Hämäläinen M, Linderborg K, Moilanen E, Isolauri E** Breast milk fatty acids may link innate and adaptive immune regulation: analysis of soluble CD14, prostaglandin E2, and fatty acids. *Pediatr Res*. 2006;**59**(5):723-7
- Laitinen K, Sallinen J, Linderborg K, Isolauri E** Serum, cheek cell and breast milk fatty acid compositions in infants with atopic and non-atopic eczema. *Clin Exp Allergy*. 2006b;**36**(2):166-73
- Lands WE** Biosynthesis of prostaglandins. *Annu Rev Nutr*. 1991;**11**:41-60
- Lapillonne A, Carlson SE** Polyunsaturated fatty acids and infant growth. *Lipids*. 2001;**36**(9):901-11
- Lauritzen L, Hoppe C, Straarup EM, Michaelsen KF** Maternal fish oil supplementation in lactation and growth during the first 2.5 years of life. *Pediatr Res*. 2005;**58**(2):235-42
- Lauritzen L, Kjaer TM, Fruekilde MB, Michaelsen KF, Frøkiaer H** Fish oil supplementation of lactating mothers affects cytokine production in 2 1/2-year-old children. *Lipids*. 2005b;**40**(7):669-76
- Lee SO, Kim CS, Cho SK, Choi HJ, Ji GE, Oh DK** Bioconversion of linoleic acid into conjugated linoleic acid during fermentation and by washed cells of *Lactobacillus reuteri*. *Biotechnol Lett*. 2003;**25**(12):935-8
- Leichsenring M, Kochsiek U, Paul K** (n-6)-fatty acids in plasma lipids of children with atopic bronchial asthma. *Pediatr Allergy Immunol* 1995;**6**:209-212
- Li J, Fan Y, Zhang Z, Yu H, An Y, Kramer JK, Deng Z** Evaluating the trans fatty acid, CLA, PUFA and erucic acid diversity in human milk from five regions in China. *Lipids*. 2009;**44**(3):257-71.
- Ljungberg M, Korpela R, Ilonen J, Ludvigsson J, Vaarala O** Probiotics for the prevention of beta cell autoimmunity in children at genetic risk of type 1 diabetes--the PRODIA study. *Ann N Y Acad Sci*. 2006;**1079**:360-4
- Lodish H, Berk A, Zipursky, SL, Matsudaira P, Baltimore D, & Darnell J** (2000). Molecular cell biology (4th ed.). New York: W.H. Freeman
- Lowe AJ, Thien FC, Stoney RM, Bennett CM, Hosking CS, Hill DJ, Carlin JB, Abramson MJ, Dharmage SC** Associations between fatty acids in colostrum and breast milk and risk of allergic disease. *Clin Exp Allergy*. 2008;**38**(11):1745-51
- Luoto R, Laitinen K, Nermes M, Isolauri E.** Impact of maternal probiotic-supplemented dietary counselling on pregnancy outcome and prenatal and postnatal growth: a double-blind, placebo-controlled study. *Br J Nutr*. 2010;**103**(12):1792-9
- Luoto R, Kalliomäki M, Laitinen K, Isolauri E.** The impact of perinatal probiotic intervention on the development of overweight and obesity: follow-up study from birth to 10 years. *Int J Obes (Lond)*. 2010b Mar 16. [Epub ahead of print]
- Madden JAJ and Hunter JO** A review of the role of the gut microflora in irritable bowel syndrome and the effects of probiotics. *Br J Nutr* 2002;**88**:S67-S72
- Majamaa H, Isolauri E, Saxelin M, Vesikari T** Lactic acid bacteria in the treatment of acute rotavirus gastroenteritis. *J Pediatr Gastroenterol Nutr*. 1995;**20**(3):333-8
- Majamaa H, Isolauri E** Probiotics: a novel approach in the management of food allergy. *J Allergy Clin Immunol*. 1997;**99**(2):179-85
- Makrides M Neumann MA, Byard RW, Simmer K, Gibson RA** Fatty acid composition of brain, retina and erythrocytes in breast- and formula-fed infants. *Am J Clin Nutr* 1994;**60**:189-194
- Makrides M, Gibson RA, McPhee AJ, Collins CT, Davis PG, Doyle LW, Simmer K, Colditz PB, Morris S, Smithers LG, Willson K, Ryan P** Neurodevelopmental outcomes of preterm infants fed high-dose docosahexaenoic acid: a randomized controlled trial. *JAMA*. 2009;**301**(2):175-82.
- Malin M, Suomalainen H, Saxelin M, Isolauri E** Promotion of IgA immune response in patients with Crohn's disease by oral bacteriotherapy with *Lactobacillus GG*. *Ann Nutr Metab*. 1996;**40**(3):137-45

- Mancini JA, Blood K, Guay J, Gordon R, Claveau D, Chan CC, Riendeau D** Cloning, expression, and up-regulation of inducible rat prostaglandin e synthase during lipopolysaccharide-induced pyresis and adjuvant-induced arthritis. *J Biol Chem* 2001;**276**(6):4469-4475
- Manku MS, Horrobin DF, Morse NL, Kyte V, Jenkins K, Wright S, Burton JL** Reduced levels of prostaglandin precursors in the blood of atopic patients: defective delta-6-desaturase function as a biochemical basis of atopy. *Prostaglandins Leukot Med* 1982;**9**:615-628
- Manku MS, Horrobin DF, Morse NL, Wright S, Burton JL** Essential fatty acids in the plasma phospholipids of patients with atopic eczema. *Br J Dermatol* 1984;**110**:643-648
- Martín R, Langa S, Reviriego C, Jiménez E, Marín ML, Xaus J, Fernández L, Rodríguez JM** Human milk is a source of lactic acid bacteria for the infant gut. *J Pediatr.* 2003;**143**(6):754-8
- Martín R, Heilig HG, Zoetendal EG, Jiménez E, Fernández L, Smidt H, Rodríguez JM** Cultivation-independent assessment of the bacterial diversity of breast milk among healthy women. *Res Microbiol.* 2007;**158**(1):31-7
- Matsumiya Y, Kato N, Watanabe K, Kato H** Molecular epidemiological study of vertical transmission of vaginal Lactobacillus species from mothers to newborn infants in Japanese, by arbitrarily primed polymerase chain reaction. *J Infect Chemother.* 2002;**8**(1):43-9
- McFarland LV**(2007) Meta-analysis of probiotics for the prevention of traveler's diarrhea. *Travel Med Infect Dis.* 2007;**5**(2):97-105
- McFarland LV** Meta-analysis of probiotics for the prevention of antibiotic associated diarrhea and the treatment of Clostridium difficile disease. *Am J Gastroenterol.* 2006;**101**(4):812-22
- Mellies MJ, Ishikawa TT, Gartside PS, Burton K, MacGee J, Allen K, Steiner PM, Brady D, Glueck CJ** Effects of varying maternal dietary fatty acids in lactating women and their infants. *Am J Clin Nutr* 1979;**32**:299-303
- Merzouk SA, Saker M, Reguig KB, Soulimane N, Merzouk H, Guermouche B, Berrouiguet AY, Hichami A, Narce M, Khan NA** N-3 polyunsaturated fatty acids modulate in-vitro T cell function in type I diabetic patients. *Lipids* 2008;**43**(6):485-97
- Micallef M, Munro I, Phang M, Garg M** Plasma n-3 Polyunsaturated Fatty Acids are negatively associated with obesity. *Br J Nutr* 2009;**102**(9):1370-4
- Miles EA, Aston L, Calder PC** In vitro effects of eicosanoids derived from different 20-carbon fatty acids on T helper type 1 and T helper type 2 cytokine production in human whole-blood cultures. *Clin Exp Allergy.* 2003;**33**(5):624-32
- Mitsou EK, Kirtzalidou E, Oikonomou I, Liosis G, Kyriacou A** Fecal microflora of Greek healthy neonates. *Anaerobe.* 2008;**14**(2):94-101
- Mitsuyama K and Sata M** Gut microflora: a new target for therapeutic approaches in inflammatory bowel disease. *Expert Opin Ther Targets.* 2008;**12**(3):301-12
- Montalto M, Curigliano V, Santoro L, Vastola M, Cammarota G, Manna R, Gasbarrini A, Gasbarrini G** Management and treatment of lactose malabsorption. *World J Gastroenterol.* 2006;**12**(2):187-91
- Moore WE, Holdeman LV** Human fecal flora: the normal flora of 20 Japanese-Hawaiians. *Appl Microbiol.* 1974 May;**27**(5):961-79
- Mu H, Porsgaard T** The metabolism of structured triacylglycerols. *Prog Lipid Res.* 2005;**44**(6):430-48
- Mu H, Høy CE** The digestion of dietary triacylglycerols. *Prog Lipid Res.* 2004;**43**(2):105-33
- Murga ML, Cabrera GM, De Valdez GF, Disalvo A, Seldes AM** Influence of growth temperature on cryotolerance and lipid composition of Lactobacillus acidophilus. *J Appl Microbiol.* 2000;**88**(2):342-8
- Musso G, Gambino R, Cassader M** Gut microbiota as a regulator of energy homeostasis and ectopic fat deposition: mechanisms and implications for metabolic disorders. *Curr Opin Lipidol.* 2009 Nov 12. [Epub ahead of print]
- Nagagomi T, Iraya H, Tominaga T, Yamaki M, Hisamasu S, Nagakomi O** Is atopy increasing? *Lancet* 1994;**343**: 121-122

- Nagakura T, Matsuda S, Shichijyo K, Sugimoto H, Hata K** Dietary supplementation with fish oil rich in omega-3 polyunsaturated fatty acids in children with bronchial asthma. *Eur Respir J.* 2000;**16(5)**:861-5
- Nagler-Anderson C** Tolerance and immunity in the intestinal immune system. *Crit Rev Immunol.* 2000;**20(2)**:103-20
- Nakamura MT, Cho HP, Xu J, Tang Z, Clarke SD** Metabolism and functions of highly unsaturated fatty acids: an update. *Lipids* 2001;**36(9)**:961-4
- Nobaek S, Johansson ML, Molin G, Ahrné S, Jeppsson B** Alteration of intestinal microflora is associated with reduction in abdominal bloating and pain in patients with irritable bowel syndrome. *Am J Gastroenterol.* 2000;**95(5)**:1231-8
- Noh DO, Kim SH, Gilliland SE** Incorporation of cholesterol into the cellular membrane of *Lactobacillus acidophilus* ATCC 43121. *J Dairy Sci.* 1997;**80(12)**:3107-13
- Oberhelman RA, Gilman RH, Sheen P, Taylor DN, Black RE, Cabrera L, Lescano AG, Meza R, Madico G** A placebo-controlled trial of *Lactobacillus GG* to prevent diarrhea in undernourished Peruvian children. *J Pediatr.* 1999;**134(1)**:15-20
- Oddy WH, Pal S, Kusel MM, Vine D, de Klerk NH, Hartmann P, Holt PG, Sly PD, Burton PR, Stanley FJ, Landau LI** Atopy, eczema and breast milk fatty acids in a high-risk cohort of children followed from birth to 5 yr. *Pediatr Allergy Immunol.* 2006;**17(1)**:4-10
- Ohashi Y, Tokunaga M, Taketomo N, Ushida K** Stimulation of indigenous lactobacilli by fermented milk prepared with probiotic bacterium, *Lactobacillus delbrueckii* subsp. *bulgaricus* strain 2038, in the pigs. *J Nutr Sci Vitaminol (Tokyo).* 2007;**53(1)**:82-6
- Ohtsuka Y, Yamashiro Y, Shimizu T, Nagata S, Igarashi J, Shinohara K, Oguchi S and Yabuta K** Reducing cell membrane n-6 fatty acids attenuate mucosal damage in food-sensitive enteropathy in mice. *Pediatr. Res.* 1997;**42**:835-839
- Oksanen PJ, Salminen S, Saxelin M, Hämäläinen P, Ihanola-Vormisto A, Muurasniemi-Isoviita L, Nikkari S, Oksanen T, Pörsti I, Salminen E, et al** Prevention of travellers' diarrhoea by *Lactobacillus GG*. *Ann Med.* 1990;**22(1)**:53-6
- Olsen SF, Østerdal ML, Salvig JD, Mortensen LM, Rytter D, Secher NJ, Henriksen TB** Fish oil intake compared with olive oil intake in late pregnancy and asthma in the offspring: 16 y of registry-based follow-up from a randomized controlled trial. *Am J Clin Nutr.* 2008;**88(1)**:167-75
- Ooi CY, Dille AV, Day AS** *Saccharomyces boulardii* in a child with recurrent *Clostridium difficile*. *Pediatr Int.* 2009;**51(1)**:156-8
- Ouwehand AC, Isolauri E, Kirjavainen PV, Salminen SJ** Adhesion of four *Bifidobacterium* strains to human intestinal mucus from subjects in different age groups. *FEMS Microbiol Lett.* 1999;**172(1)**:61-4
- Ouwehand A, Kirjavainen P, Shortt C & Salminen S** Probiotics: Mechanisms and Established Effects, *Int. Dairy J.* 1999b;**9**:43-52.
- Ouwehand A, Isolauri E and Salminen S** The role of the intestinal microflora for the development of the immune system in early childhood. *Eur J Nutr.* 2002;**41 Suppl 1**:132-7
- Partanen L, Marttinen N and Alatosava T,** Fats and fatty acids as growth factors for *Lactobacillus delbrueckii*. *Syst. Appl. Microbiol.* 2001;**24**:500-506
- Pelto L, Isolauri E, Lilius EM, Nuutila J, Salminen S** Probiotic bacteria down-regulate the milk-induced inflammatory response in milk-hypersensitive subjects but have an immunostimulatory effect in healthy subjects. *Clin Exp Allergy.* 1998;**28(12)**:1474-9
- Pereira DIA and Gibron GR** Cholesterol assimilation by lactic acid bacteria and bifidobacteria isolated from the human gut. *Appl Environ Microbiol* 2002;**66(9)**:4689-4693
- Pessi T, Sütas Y, Marttinen A, Isolauri E** Probiotics reinforce mucosal degradation of antigens in rats: implications for therapeutic use of probiotics. *J Nutr.* 1998;**128(12)**:2313-8
- Pessi T, Sütas Y, Saxelin M, Kallioinen H, Isolauri E** Antiproliferative effects of homogenates derived from five strains of candidate probiotic bacteria. *Appl Environ Microbiol.* 1999;**65(11)**:4725-8
- Pessi T, Sütas Y, Hurme M, Isolauri E** Interleukin-10 generation in atopic children following oral *Lactobacillus rhamnosus GG*. *Clin Exp Allergy.* 2000;**30(12)**:1804-8

- Pessi T, Isolauri E, Sütas Y, Kankaanranta H, Moilanen E, Hurme M** Suppression of T-cell activation by *Lactobacillus rhamnosus* GG-degraded bovine casein. *Int Immunopharmacol.* 2001;**1(2)**:211-8
- Peters-Golden M and Brock TG** Intracellular compartmentalization of leukotriene synthesis: unexpected nuclear secrets *FEBS Lett* 2001;**487(3)**:323-326
- Piuri M, Sanchez-Rivas C, Ruzal SM** Cell wall modifications during osmotic stress in *Lactobacillus casei*. *J Appl Microbiol.* 2005;**98(1)**:84-95
- Putnam JC, Carlson SE, DeVoe PW, Barness LA** The effect of variations in dietary fatty acids on the fatty acid composition of erythrocyte phosphatidylcholine and phosphatidylethanolamine in human infants. *Am J Clin Nutr.* 1982;**36(1)**:106-14
- Rafter J** Probiotics and colon cancer. *Best Pract Res Clin Gastroenterol.* 2003;**17(5)**:849-59
- Rajilić-Stojanović M, Heilig HG, Molenaar D, Kajander K, Surakka A, Smidt H, de Vos WM** Development and application of the human intestinal tract chip, a phylogenetic microarray: analysis of universally conserved phylotypes in the abundant microbiota of young and elderly adults. *Environ Microbiol.* 2009 Mar 10. [Epub ahead of print]
- Rastas M, Seppänen R, Knuts LR, Karvetti RL and Varo P.** Nutrient composition of foods. Helsinki:Publication of the Social Insurance Institution 1993
- Rautava S, Arvilommi H, Isolauri E** Specific probiotics in enhancing maturation of IgA responses in formula-fed infants. *Pediatr Res.* 2006;**60(2)**:221-4
- Reynolds CM, Roche HM** Conjugated linoleic acid and inflammatory cell signalling. *Prostaglandins Leukot Essent Fatty Acids.* 2010;**82(4-6)**:199-204
- Rhee KJ, Jasper PJ, Sethupathi P, Shanmugam M, Lanning D, Knight KL** Positive selection of the peripheral B cell repertoire in gut-associated lymphoid tissues. *J Exp Med.* 2005;**201(1)**:55-62
- Rhee KJ, Sethupathi P, Driks A, Lanning DK, Knight KL** Role of commensal bacteria in development of gut-associated lymphoid tissues and preimmune antibody repertoire. *J Immunol.* 2004;**172(2)**:1118-24
- Romagnani S** The role of lymphocytes in allergic disease. *J Allergy Clin Immunol* 2000;**105**:399-408
- Ringø E, Bendiksen HR, Gausen SJ, Sundsfjord A and Olsen RE** The effect of dietary fatty acids on lactic acid bacteria associated with the epithelial mucosa and form faecalia of Arctic charr, *Salvelinus alpinus* (L.). *J Appl Microbiol* 1998;**85**:855-864
- Roper RL and Phipps RP** Prostaglandin E2 regulation of the immune response. *Adv Prostaglandin Thromboxane Leukot Res* 1994;**22**:101-111
- Rosenfeldt V, Benfeldt E, Valerius NH, Paerregaard A, Michaelsen KF** Effect of probiotics on gastrointestinal symptoms and small intestinal permeability in children with atopic dermatitis. *J Pediatr.* 2004;**145(5)**:612-6
- Rotimi VO, Duerden BI** The development of the bacterial flora in normal neonates. *J Med Microbiol.* 1981;**14(1)**:51-62
- Ruan C, Liu X, Man H, Ma X, Lu G, Duan G, DeFrancesco CA, Connor WE** Milk composition in women from five different regions of China: the great diversity of milk fatty acids. *J Nutr.* 1995;**125(12)**:2993-8
- Rupnik M, Wilcox MH, Gerding DN** *Clostridium difficile* infection: new developments in epidemiology and pathogenesis. *Nat Rev Microbiol* 2009;**7(7)**:526-536
- Russell NJ & Nichols DS** Polyunsaturated Fatty Acids in Marine Bacteria - a Dogma Rewritten, *Microbiol.* 1999;**145**:767-779
- Ruszczyński M, Radzikowski A, Szajewska H** Clinical trial: effectiveness of *Lactobacillus rhamnosus* (strains E/N, Oxy and Pen) in the prevention of antibiotic-associated diarrhoea in children. *Aliment Pharmacol Ther.* 2008;**28(1)**:154-61
- Saadatian-Elahi M, Slimani N, Chajès V, Jenab M, Goudable J, Biessy C, Ferrari P, Byrnes G, Autier P, Peeters PH, Ocké M, Bueno de Mesquita B, Johansson I, Hallmans G, Manjer J, Wirfält E, González CA, Navarro C, Martínez C, Amiano P, Suárez LR, Ardanaz E, Tjønneland A, Halkjaer J, Overvad K, Jakobsen MU, Berrino F, Pala V, Palli D, Tumino R, Vineis P, Santucci de Magistris M, Spencer EA, Crowe FL, Bingham S, Khaw KT, Linseisen J, Rohrmann S, Boeing H, Nothlings U, Olsen KS, Skeie G, Lund E, Trichopoulou A, Oustoglou E, Clavel-Chapelon F, Riboli E.** Plasma phospholipid fatty acid

- profiles and their association with food intakes: results from a cross-sectional study within the European Prospective Investigation into Cancer and Nutrition. *Am J Clin Nutr.* 2009;**89**(1):331-46
- Saavedra JM, Bauman NA, Oung I, Perman JA and Yolken RH** Feeding of *Bifidobacterium bifidum* and *Streptococcus thermophilus* to infants in hospital for prevention of diarrhoea and shedding of rotavirus. *Lancet* 1994;**344**:1046-1049
- Sala-Vila A, Miles EA, Calder PC** Fatty acid composition abnormalities in atopic disease: evidence explored and role in the disease process examined. *Clin Exp Allergy* 2008;**38**(9):1432-50
- Salminen MK, Rautelin H, Tynkkynen S, Poussa T, Saxelin M, Valtonen V, Järvinen A** *Lactobacillus* bacteremia, clinical significance, and patient outcome, with special focus on probiotic *L. rhamnosus* GG. *Clin Infect Dis.* 2004;**38**(1):62-9
- Salminen S, Isolauri E and Salminen E** Clinical uses of probiotics for stabilizing the gut mucosal barrier: successful strains and future challenges. *Antonie Van Leeuwenhoek.* 1996;**70**(2-4):347-58
- Salminen M, Tynkkynen S, Rautelin H, Saxelin M, Vaara M, Ruutu P, Sarna S, Valtonen V, Järvinen A.** *Lactobacillus* bacteremia during a rapid increase in probiotic use of *Lactobacillus rhamnosus* GG in Finland. *Clin Infect Dis* 2002;**35**:1155-1160
- Salminen SJ, Gueimonde M and Isolauri E** Probiotic that modify disease risk. *J Nutr* 2005;**135**:1294-1298
- Samuelsson B** Leukotrienes: mediators of immediate hypersensitivity reactions and inflammation *Science* 1983;**220**(4597):568-575
- Sanders TAB and Reddy S** The influence of a vegetarian diet on fatty acid composition of human milk and the essential fatty acid status of the infant. *J Pediatr* 1992;**120**:S71-S77
- Sanders ME** Probiotics: Considerations for human health. *Nutr Rev* 2003;**61**(3):91-99
- Sanders ME, Hamilton J, Reid G, Gibson G** A nonviable preparation of *Lactobacillus acidophilus* is not a probiotic. *Clin Infect Dis.* 2007;**44**(6):886
- Sauerwald TU, Hachey DL, Jensen CL, Chen H, Anderson RE, Heird WC** Intermediates in endogenous synthesis of C22:6 omega 3 and C20:4 omega 6 by term and preterm infants. *Pediatr Res.* 1997;**41**(2):183-7
- Sauerwald TU, Demmelmair H, Koletzko B.** Polyunsaturated fatty acid supply with human milk. *Lipids* 2001;**36**(9):991-996
- Saulnier DM, Kolida S, Gibson GR** Microbiology of the human intestinal tract and approaches for its dietary modulation. *Curr Pharm Des.* 2009;**15**(13):1403-14
- Schachter HM, Reisman J, Tran K, Dales B, Kourad K, Barnes D, Sampson M, Morrison A, Gaboury I, Blackman J** Health effects of omega-3 fatty acids on asthma. Summary, evidence report / Technology Assessment No.91 (Prepared by the University of Ottawa Evidence-based Practice Center, Ottawa, Canada) AHRQ Publication No. 04-E013-1. Rockville, MD: Agency for Healthcare Research and Quality. March 2004
- Schmidt EB, Pedersen JO, Ekelund S, Grunnet N, Jersild C, Dyerberg J** Cod liver oil inhibits neutrophil and monocyte chemotaxis in healthy males. *Atherosclerosis* 1989;**77**:53-57
- Schrezenmeir J, de Vrese M** Probiotics, prebiotics, and synbiotics--approaching a definition. *Am J Clin Nutr.* 2001;**73**(2 Suppl):361S-364S
- Schubert R, Kitz R, Beermann C, Rose MA, Lieb A, Sommerer PC, Moskovits J, Alberternst H, Böhles HJ, Schulze J, Zielen S** Effect of n-3 polyunsaturated fatty acids in asthma after low-dose allergen challenge. *Int Arch Allergy Immunol.* 2009;**148**(4):321-9
- Sears MR, Greene JM, Willan AR, Taylor DR, Flannery EM, Cowan JO, Herbison GP, Poulton R** Long-term relation between breastfeeding and development of atopy and asthma in children and young adults: a longitudinal study. *Lancet* 2002;**360**(9337):901-7
- Seksik P, Dray X, Sokol H, Marteau P** Is there any place for alimentary probiotics, prebiotics or synbiotics, for patients with inflammatory bowel disease? *Mol Nutr Food Res.* 2008;**52**(8):906-12
- Shapiro H** Could n-3 polyunsaturated fatty acids reduce pathological pain by direct actions on the nervous system? *Prostaglandins Leukot Essent Fatty Acids.* 2003;**68**(3):219-24

- Shida K, Makino K, Morishita A, Takamizawa K, Hachimura S, Ametani A, Sato T, Kumagai Y, Habu S, Kaminogawa S** Lactobacillus casei inhibits antigen-induced IgE secretion through regulation of cytokine production in murine splenocyte cultures. *Int Arch Allergy Immunol.* 1998;**115**(4):278-87
- Shimizu T, Fujii T, Suzuki R, Igarashi J, Ohtsuka Y, Nagata S, Yamashiro Y** Effects of highly purified eicosapentaenoic acid on erythrocyte fatty acid composition and leukocyte and colonic mucosa leukotriene B4 production in children with ulcerative colitis. *J Pediatr Gastroenterol Nutr.* 2003;**37**(5):581-5.
- Shornikova AV, Casas IA, Mykkänen H, Salo E, Vesikari T** Bacteriotherapy with Lactobacillus reuteri in rotavirus gastroenteritis. *Pediatr Infect Dis J.* 1997;**16**(12):1103-7
- Simopoulos AP.** Omega-3 fatty acids in health and disease and in growth and development. *Am. J. Clin. Nutr.* 1991;**54**:438-463
- Simopoulos AP** Omega-3 fatty acids in inflammation and autoimmune diseases. *J Am Coll Nutr.* 2002;**21**(6):495-505
- Simopoulos AP** Evolutionary aspects of diet, the omega-6/omega-3 ratio and genetic variation: nutritional implications for chronic diseases. *Biomed Pharmacother.* 2006;**60**(9):502-7
- Simopoulos AP** The importance of the omega-6/omega-3 fatty acid ratio in cardiovascular disease and other chronic diseases. *Exp Biol Med (Maywood).* 2008;**233**(6):674-88
- Singer SJ and Nicholson GL** The fluid mosaic model of the structure of cell membranes. *Science* 1972;**175**:720
- Smith WL, DeWitt DL, and Garavito RM** Cyclooxygenases: structural, cellular, and molecular biology. *Annu Rev Biochem.* 2000;**69**:145-82
- Snydman DR** The safety of probiotics. *Clin Infect Dis.* 2008;**46 Suppl 2**:S104-11; discussion S144-51
- Sokol H, Pigneur B, Watterlot L, Lakhdari O, Bermúdez-Humarán LG, Gratadoux JJ, Blugeon S, Bridonneau C, Furet JP, Corthier G, Grange C, Vasquez N, Pochart P, Trugnan G, Thomas G, Blottière HM, Doré J, Marteau P, Seksik P, Langella P** Faecalibacterium prausnitzii is an anti-inflammatory commensal bacterium identified by gut microbiota analysis of Crohn disease patients. *Proc Natl Acad Sci U S A.* 2008;**105**(43):16731-6
- Sprecher H, Luthria DL, Mohammed BS, Baykousheva SP** Reevaluation of the pathways for the biosynthesis of polyunsaturated fatty acids. *J Lipid Res* 1995;**36**(12):2471-7
- Stark PL, Lee A** The microbial ecology of the large bowel of breast-fed and formula-fed infants during the first year of life. *J Med Microbiol.* 1982;**15**(2):189-203
- Stappenbeck TS, Hooper LV, Gordon JI** Developmental regulation of intestinal angiogenesis by indigenous microbes via Paneth cells. *Proc Natl Acad Sci U S A.* 2002;**99**(24):15451-5
- Strachan DP,** Hay fever, hygiene, and household size. *BMJ* 1989;**299**:1259-1260
- St-Onge M-P, Farnworth ER and Jones PJH** Consumption of fermented and nonfermented dairy products: effects on cholesterol concentrations and metabolism. *Am J Clin Nutr* 2000;**71**:674-681
- Stoney RM, Woods RK, Hosking CS, Hill DJ, Abramson MJ, Thien FC** Maternal breast milk long-chain n-3 fatty acids are associated with increased risk of atopy in breastfed infants. *Clin Exp Allergy.* 2004;**34**(2):194-200
- Suau A, Bonnet R, Sutren M, Godon JJ, Gibson GR, Collins MD, Doré J** Direct analysis of genes encoding 16S rRNA from complex communities reveals many novel molecular species within the human gut. *Appl Environ Microbiol.* 1999;**65**(11):4799-807
- Sudo N, Sawamura S, Tanaka K, Aiba Y, Kubo C, Koga Y** The requirement of intestinal bacterial flora for the development of an IgE production system fully susceptible to oral tolerance induction. *J Immunol.* 1997;**159**(4):1739-45
- Surawicz CM, Elmer GW, Speelman P, McFarland LV, Chinn J, van Belle G** Prevention of antibiotic-associated diarrhea by Saccharomyces boulardii: a prospective study. *Gastroenterol* 1989;**96**(4):981-8
- Surawicz CM, McFarland LV, Greenberg RN, Rubin M, Fekety R, Mulligan ME, Garcia RJ, Brandmarker S, Bowen K, Borjal D, Elmer GW** The search for a better treatment for recurrent Clostridium difficile disease: use of high-dose vancomycin combined with Saccharomyces boulardii. *Clin Infect Dis.* 2000;**31**(4):1012-7

- Surette ME, Stull D, Lindemann J** The impact of a medical food containing gammalinolenic and eicosapentaenoic acids on asthma management and the quality of life of adult asthma patients. *Curr Med Res Opin.* 2008;**24(2)**:559-67
- Sütas Y, Hurme M, Isolauri E** Down-regulation of anti-CD3 antibody-induced IL-4 production by bovine caseins hydrolysed with Lactobacillus GG-derived enzymes. *Scand J Immunol.* 1996;**43(6)**:687-9
- Suutari M & Laakso S** Temperature Adaptation in Lactobacillus fermentum: Interconversion of Oleic Acid, Vaccenic Acid and Dihydrosterculic Acid. *J Gen Microbiol* 1992;**138**:445-450
- Szajewska H, Kotowska M, Mrukowicz JZ, Armańska M, Mikolajczyk W** Efficacy of Lactobacillus GG in prevention of nosocomial diarrhea in infants. *J Pediatr.* 2001;**138(3)**:361-5
- Tannock GW, Fuller R, Smith SL, Hall MA** Plasmid profiling of members of the family Enterobacteriaceae, lactobacilli, and bifidobacteria to study the transmission of bacteria from mother to infant. *J Clin Microbiol.* 1990;**28(6)**:1225-8
- Thies F, Miles EA, Nebe-von-Caron G, Powell JR, Hurst TL, Newsholme EA, Calder PC** Influence of dietary supplementation with long chain n-3 and n-6 polyunsaturated fatty acids on blood inflammatory cell populations and functions and on plasma soluble adhesion molecules in healthy adults. *Lipids* 2001;**36**:1183-1193
- Tommasi C, Equitani F, Masala M, Ballardini M, Favaro M, Meledandri M, Fontana C, Narciso P, Nicastrì E** Diagnostic difficulties of Lactobacillus casei bacteraemia in immunocompetent patients: a case report. *J Med Case Reports.* 2008;**2**:315
- Trebbles TM, Arden NK, Wootton SA, Calder PC, Mullee MA, Fine DR, Stroud MA** Fish oil and antioxidants alter the composition and function of circulating mononuclear cells in Crohn disease. *Am J Clin Nutr.* 2004;**80(5)**:1137-44.
- Tuomola EM and Salminen SJ.** Adhesion of some probiotic and dairy *Lactobacillus* strains to Caco-2 cell cultures. *Int. J. Food Microbiol.* 1998;**41**:45-51
- Tuomola E, Crittenden R, Playne M, Isolauri E, Salminen S** Quality assurance criteria for probiotic bacteria. *Am J Clin Nutr.* 2001;**73(2 Suppl)**:393S-398S
- Ulisse S, Gionchetti P, D'Alò S, Russo FP, Pesce I, Ricci G, Rizzello F, Helwig U, Cifone MG, Campieri M, De Simone C** Expression of cytokines, inducible nitric oxide synthase, and matrix metalloproteinases in pouchitis: effects of probiotic treatment. *Am J Gastroenterol* 2001;**96(9)**:2691-9
- van der Aa LB, Heymans HS, van Aalderen WM, Sprickelman AB** Probiotics and prebiotics in atopic dermatitis: review of the theoretical background and clinical evidence. *Pediatr Allergy Immunol.* 2009 Jul 2. [Epub ahead of print]
- van Nieuwenhove CP, Oliszewski R, González SN, Pérez Chaia AB** Conjugated linoleic acid conversion by dairy bacteria cultured in MRS broth and buffalo milk. *Lett Appl Microbiol.* 2007;**44(5)**:467-74
- van Odijk J, Kull I, Borres MP, Brandtzaeg P, Edberg U, Hanson LA, Høst A, Kuitunen M, Olsen SF, Skerfving S, Sundell J, Wille S** Breastfeeding and allergic disease: a multidisciplinary review of the literature (1966-2001) on the mode of early feeding in infancy and its impact on later atopic manifestations. *Allergy* 2003;**58(9)**:833-43
- Vesa TH, Marteau P, Korpela R** Lactose intolerance. *J Am Coll Nutr.* 2000;**19(2 Suppl)**:165S-175S
- Viljanen M, Savilahti E, Haahtela T, Juntunen-Backman K, Korpela R, Poussa T, Tuure T, Kuitunen M** Probiotics in the treatment of atopic eczema/dermatitis syndrome in infants: a double-blind placebo-controlled trial. *Allergy.* 2005;**60(4)**:494-500
- Villena J, Barbieri N, Salva S, Herrera M, Alvarez S** Enhanced immune response to pneumococcal infection in malnourished mice nasally treated with heat-killed Lactobacillus casei. *Microbiol Immunol.* 2009;**53(11)**:636-46
- Vinderola CG, Medici M, Perdígón G** Relationship between interaction sites in the gut, hydrophobicity, mucosal immunomodulating capacities and cell wall protein profiles in indigenous and exogenous bacteria. *J Appl Microbiol.* 2004;**96(2)**:230-43
- Virta M, Lineri S, Kankaanpää P, Karp M, Peltonen K, Nuutila J and Lilius E-M** Determination of complement-mediated killing of bacteria by viability staining and bioluminescence *Appl. Environ. Microbiol.* 1998;**64**:515-519

- Wadstrom T, Andersson K, Sydow M, Axelsson L, Lindgren S & Gullmar B** Surface Properties of Lactobacilli Isolated from the Small Intestine of Pigs. *J. Appl. Bacteriol.* 1987;**62**:513-20
- Waitzberg DL, Torrinhas RS** Fish oil lipid emulsions and immune response: what clinicians need to know. *Nutr Clin Pract.* 2009;**24**(4):487-99
- Wang D and DuBois RN** Peroxisome proliferator-activated receptors and progression of colorectal cancer. *PPAR Res.* 2008;**2008**:931074
- Wanten GJ and Calder PC** Immune modulation by parenteral lipid emulsions. *Am J Clin Nutr.* 2007;**85**(5):1171-84
- Warstedt K, Furuhejm C, Duchén K, Fälth-Magnusson K, Fagerås M** The effects of omega-3 fatty acid supplementation in pregnancy on maternal eicosanoid, cytokine, and chemokine secretion. *Pediatr Res.* 2009;**66**(2):212-7
- Watanabe K, Ishikawa C, Inoue H, Cenhuo D, Yazawa K & Kondo K** Incorporation of Exogenous Docosahexaenoic Acid into Various Bacterial Lipids. *J Am Oil Chem Soc* 1994;**71**:325-330
- Wheeler JG, Shema SJ, Bogle ML, Shirrell MA, Burks AW, Pittler A, Helm RM** Immune and clinical impact of Lactobacillus acidophilus on asthma. *Ann Allergy Asthma Immunol.* 1997;**79**(3):229-33
- Winklet O, Holtz H, Doring A** Comparison of food intakes of selected populations in former East and West Germany: results from MONICA projects, Erfurt and Augsburg. *Ann Nutr Metab* 1992;**36**: 219-234
- Wolters M** Diet and psoriasis: experimental data and clinical evidence. *Br J Dermatol.* 2005;**153**(4):706-14
- Woods RK, Thien FC, Abramson MJ** Dietary marine fatty acids (fish oil) for asthma in adults and children. *Cochrane Database Syst Rev.* 2002;**(3)**:CD001283.
- Wu D** Modulation of immune and inflammatory responses by dietary lipids. *Curr Opinion in Lipidol* 2004;**15**:43-47
- Wynn JP & Ratledge C** Evidence that The Rate-limiting Step for The Biosynthesis of Arachidonic Acid in *Mortierella alpina* is at The Level of The 18:3 to 20:3 Elongase. *Microbiol.* 2000;**146**:2325-2331
- Yang B, Kalimo K, Mattila L, Kallio S, Katajisto J, Peltola O and Kallio H,** Effects of Dietary Supplementation with Sea Buckthorn (*Hippophaë rhamnoides*) Seed and Pulp Oils on Atopic Dermatitis. *J. Nutr. Biochem.* 1999;**10**:622-630
- Yu G, Duchén K, Björkstén B** Fatty acid composition in colostrum and mature milk from non-atopic and atopic mothers during the first months of lactation. *Acta Paediatr* 1998(a);**87**:729-736
- Yu G, Björkstén B** Serum levels of phospholipid fatty acids in mothers and their babies in relation to allergic disease. *Eur J Paediatr* 1998(b);**157**:298-303
- Zhou L and Nilsson Å** Sources of eicosanoid precursor fatty acid pools in tissue. *J Lipid Res* 2001;**42**:1521-1542
- Ågren JJ, Julkunen A, Penttilä I.** Rapid separation of serum lipids for fatty acid analysis by a single aminopropyl column. *J Lipid Res* 1992;**33**:1871-1876