

**UNIVERSITY OF VAASA**

**FACULTY OF TECHNOLOGY**

**TELECOMMUNICATIONS ENGINEERING**

Teemu Ahonen

**GREENHOUSE MONITORING WITH WIRELESS SENSOR NETWORK**

Master's thesis for the degree of Master of Science in Technology submitted for inspection in Vaasa, 11<sup>th</sup> of May 2008.

Supervisor                      D. Sc. (Tech.) Mohammed Salem Elmusrati

Instructor                      M. Sc. (Tech.) Reino Virrankoski

## **ACKNOWLEDGEMENTS**

First I would like to express my deepest appreciation to Prof. Mohammed Elmusrati and M.Sc. Reino Virrankoski for guidance and valuable advice throughout this Master's Thesis.

I am also thankful to Lab. Engineer Veli-Matti Eskonen for helping and providing the required tools of the test setup.

Thanks to my family for their endless encouragement. Special thanks to my loving girlfriend, Tiia. Without your mental support this Thesis would not be completed.

## TABLE OF CONTENTS

ACKNOWLEDGEMENTS.....	2
TABLE OF CONTENTS .....	3
ABBREVIATIONS.....	5
ABSTRACT .....	8
1 INTRODUCTION .....	9
2 INTELLIGENT GREENHOUSE .....	11
2.1 Plant developmental factors.....	11
2.2 Greenhouse control.....	15
2.3 Wireless sensor network in greenhouses .....	19
3 IEEE 802.15.4 WIRELESS SENSOR NETWORKS .....	26
3.1 Birth of the IEEE 802.15.4 standard .....	26
3.2 Architecture .....	28
3.3 LR-WPAN components.....	30
3.4 Topologies of wireless sensor networks .....	31
3.5 Data transfer and synchronizing of transmissions .....	34
4 ZIGBEE AND 6LoWPAN .....	37
4.1 Structure of the ZigBee and its features.....	38
4.2 Binding .....	40
4.3 Security of transmission in ZigBee .....	41
4.4 6LoWPAN .....	42
4.5 6LoWPAN in IPv4 network.....	44
5 THE WIRELESS SENSOR NODES.....	47
5.1 Elements of the nodes.....	47
5.2 Berkeley Motes .....	51

5.3 ZigBee radio nodes .....	56
6 APPLIED SENSOR NODES .....	58
6.1 Sensinode's sensing platforms .....	58
6.1.1 U100 Micro.2420 .....	59
6.1.2 Micro.usb U600.....	60
6.1.3 Proto sensor board .....	61
6.2 Nanostack.....	64
6.2.1 nRoute Protocol and daemon.....	65
6.2.2 SSI protocol .....	66
6.3 Software.....	67
6.3.1 Sensor node application.....	68
6.3.2 Sensor data collector application.....	69
7 MEASURING ENVIRONMENT .....	72
7.1 Martens greenhouse research foundation.....	73
7.2 Network topology .....	74
7.3 Data collecting .....	76
8 EXPERIMENTS AND RESULTS.....	79
8.1 Power management.....	79
8.2 Network throughput .....	80
8.3 Results.....	81
9 CONCLUSIONS AND THE FUTURE WORK .....	86
REFERENCES.....	88

**ABBREVIATIONS**

6LoWPAN	IPv6-based Low-power Wireless Personal Area Networks
ACL	Access Control List
ADC	Analog-to-Digital Converter
AES	Advanced Encryption Standard
ARM	Advanced RISC Machine
BodyLAN	Body Local Area Network
BPSK	Binary Phase-Shift Keying
CAP	Contention Access Period
CBC-MAC	Cipher Block Chaining Message Authentication Code
CCM	Counter with CBC-MAC
CFP	Contention Free Period
CID	Cluster Identifier
CLH	Cluster Head
CO <sub>2</sub>	Carbon Dioxide
CSMA-CA	Carrier Sense Multiple Access with Collision Avoidance
CRC	Cyclic Redundancy Check
CTR	Counter Mode Encryption
DARPA	Defence Advanced Research Programs Agency
DFSS	Distributed Frequency Spread Spectrum
DAC	Digital-to-Analog Converter
DMA	Direct Memory Access
DSSS	Direct Sequence Spread Spectrum
ESD	Electrostatic Sensitive Device

FFD	Full Function Device
FHSS	Frequency Hopping Spread Spectrum
FTDI	Future Technology Devices International
GPRS	General Packet Radio Service
GSM	Global System for Mobile Communications
GTS	Guaranteed Time Slot
HID	High Intensity Discharge
GCC	GNU Compiler Collection
ICMP	Internet Control Message Protocol
IEEE	Institute of Electrical and Electronics Engineers
IETF	Internet Engineering Task Force
IIC	Inter-Integrated Circuit
IPv4	Internet Protocol version 4
IPv6	Internet Protocol version 6
ISM	Industry, Scientific and Medical
LAN	Local Area Network
LCD	Liquid Crystal Display
LED	Light-Emitting-Diode
LLC	Logical Link Control
LR –WPAN	Low Rate Wireless Personal Area Network
MAC	Medium Access Control
MSB	Most Significant Bit/Byte
NAT	Network Address Translation
NAT-PT	Network Address Translation-Protocol Translation
nRP	nRouted Protocol

O-QPSK	Offset Quadrature Phase-Shift Keying
OSI	Open System Interconnection
PC	Personal Computer
PCB	Print Circuit Board
POSIX	Portable Operating System Interface
RAM	Random Access Memory
RFD	Reduced Function Device
RISC	Reduced Instruction Set Computer
ROM	Read Only Memory
RS-232	Recommended Standard 232
RSSI	Received Signal Strength Identifier
RTOS	Real Time Operating System
SMS	Short Message Service
SPI	Serial Peripheral Interface
SSCS	Service Specific Convergence Sublayer
SSI	Simple Sensor Interface
TCP	Transmission Control Protocol
TDMA	Time Division Multiple Access
UART	Universal Asynchronous Receiver/Transmitter
USART	Universal Synchronous Receiver/Transmitter
USB	Universal Serial Bus
WLAN	Wireless Local Area Network
WPAN	Wireless Personal Area Network
WSN	Wireless Sensor Network

---

**UNIVERSITY OF VAASA****Faculty of technology**

<b>Author:</b>	Teemu Ahonen
<b>Topic of the Thesis:</b>	Greenhouse Monitoring with Wireless Sensor Network
<b>Supervisor:</b>	Mohammed Elmusrati
<b>Instructor:</b>	Reino Virrankoski
<b>Degree:</b>	Master of Science in Technology
<b>Department:</b>	Department of Computer Science
<b>Degree Programme:</b>	Degree Programme in Information Technology
<b>Major of Subject:</b>	Telecommunication Engineering
<b>Year of Entering the University:</b>	2003
<b>Year of Completing the Thesis:</b>	2008
	<b>Pages: 94</b>

---

**ABSTRACT:** Financially profitable greenhouses are fully automated. The producer defines the monitoring limits for the ideal growth environment and then, the system controls automatically each adjustment to keep indoor climate at the optimal level. Increasing greenhouse sizes have forced the producers to use several measurement points for tracking the changes in the environment, thus enabling energy saving and more accurate adjustments. When each measurement point needs its own wire, the costs and cabling work increase exponentially. Once the measurement spot has been built, it is tedious to be relocated. Wireless sensor networks are gained ground in various industries. Agriculture and especially microclimate monitoring and controlling have many promising targets where the benefits of wireless devices can be exploited.

In this M.Sc. thesis we discuss the wireless sensor networks applications for greenhouses monitoring. Moreover, we have built the system practically and assist the applicability of such wireless networks through real-side measurements. Star topology network measured temperature, humidity and irradiance –important developmental factors of the plants in Martens greenhouse research foundation. Test setup greenhouse was divided into vertical blocks and nodes monitor one block at a time. The idea of the vertical distribution was to gather information about the differences occurs in the climate between lower and upper flora. The measurement results proved the functionality and reliability of the wireless sensor network inside the dense and high moisture greenhouse.

---

**KEYWORDS:** WSN, greenhouse monitoring, IEEE 802.15.4, 6LoWPAN.



## 1 INTRODUCTION

The agricultural growing has developed with huge leaps towards more effective and automated way since the 90's. Nowadays, the greenhouse does not only provide shelter for year-round producing in places where the climate would otherwise be impossible for the growing, but it also enables optimum circumstances for the growth through constant controlling. Financially profitable greenhouses are fully automated. The producer can define the monitoring limits for the ideal growth environment and then, the system controls automatically each adjustment to keep indoor climate at the optimal level. Large sizes of modern greenhouses have forced the producers to use several measurement points for tracking the changes in the environment. When each measurement point needs its own wire, the costs and cabling work increase exponentially. Once the measurement spot has been built, it is tedious to be relocated. Impractical cables must step aside and wireless solutions fill their place.

Developing different kinds of wireless devices has been a big trend in the last decade. One of the newest incomer is Wireless Sensor Network (WSN). The birth of the WSN has been a result of a few forerunner wireless projects (See Chapter 5.) and IEEE 802.15.4 standard, which defines the technique for the short range, low power wireless communication. Its functionalities are purposely developed to the communication between sensor nodes. Standard defines advisedly only two lower Open System Interconnection (OSI) layers leaving the upper layers open for different solutions. Two totally different networking solutions, ZigBee

and IPv6-based Low-power Wireless Personal Area Networks (6LoWPAN) are presented in this paper.

Wireless Sensor Networks are gaining ground in various industries. Agriculture and especially microclimate monitoring have many promising targets where the benefits of WSN can be exploited. In my Master Thesis work I concentrate on building wireless sensor network using 6LoWPAN protocol for the greenhouse monitoring. Star topology network is made with Sensinode's wireless sensing platform equipped with temperature, luminosity and humidity sensors. Measurement experiments were made Martens foundation's greenhouse at Närpiö town in Western Finland (Martens).

## **2 INTELLIGENT GREENHOUSE**

A greenhouse enables the grower to produce plants in places where the climate would otherwise be unfeasible for the growing. Environment controlling is possible in greenhouses, and the producing of plants does not depend on geographic location or the time of the year. Crops are protected inside the greenhouse from extreme temperatures, winds, rain, snow, sleet, hail, insects and diseases. Not only does the greenhouse provide shelter from extreme weather conditions, it also ables optimum circumstances for the growth through constant controlling. Heating and artificial lighting guarantee needed temperature and brightness even in winter. The levels of fertilizer and water can easily be added in order to achieve optimum growth. (Salminen 1998), (Petersen 1981) & (Åberg Secher 1998).

### **2.1 Plant developmental factors**

The most important monitoring factors for the quality and productivity of plant growth are temperature, humidity, light and carbon dioxide levels. Continuous monitoring of these envromental variables gives information to the grower to better understand, how each factor affects growth and how to manage maximal crop productiveness (Åberg Secher 1998). The optimal adjustment can enable a huge energy saving especially during the winter in northern countries.

The air temperature in greenhouse depends on the intended level for the photosynthetic activity of the plant. Each plant species requires its own optimal air temperature and active radiation of light (See Figure 1), which enable maximum photosynthetic activity. Soil temperature plays also an important role. Conduction heat transfers directly to the soil structure and through convection between the plant roots and water flow around them. (Arkko, Hämäläinen-Forslund, Koskinen, Krannula, Miettinen A., Miettinen T., Saario & Vainio 1995).

A major consideration in humidity and temperature control is providing the best conductivity to active movement of water and nutrients through the plant (Greenhouse guide). Humidity monitoring is also a valuable tool to prevent diseases in greenhouses. Normally, healthy relative humidity for the plants is from 50% to 70%. Higher moisture of the air helps in reducing the watering frequency of plants. Watering and misting system can be in use, if moisture of the air is under the pursued level (Arkko etc. 1995). Temperature and humidity are closely linked together in a greenhouse. Cold air has a lower moisture-holding capacity than warmer air, therefore lowering of the relative humidity is a sign of increased air temperature. Transpiration rate tells how many grams plant's leaf surface called stomata releases water vapour per minute. This important value is influenced by water, light, carbon dioxide and humidity of the air. (Timmerman & Kamp 2003).

Plants are protected inside the greenhouse from extreme weather conditions. However, the growing is not possible if the period of daylight prevents the

photosynthetic activity of the plants. Horticultural lighting allows the grower to extend the growing season. It enables year-round producing of plants or makes it possible for the grower to start seeding in early spring and continue season till the first frost. Plants need about 10-12 hours light to improve growth. (Åberg Secher 1998). When plants are producing flowers or fruits the supplemental light per day increases up to 16 hours. Figure 1 shows what kind of radiation of the light is the most suitable for the plants.

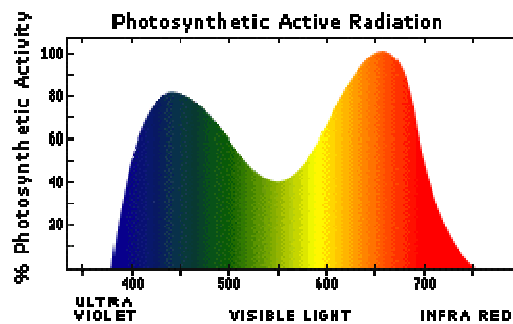

**Figure 1.** Photosynthetic activity in different light radiations.

Three main horticultural lighting systems are normally used. High Intensity Discharge (HID) lighting is one of the most efficient ways to transform electricity into light. Two types of HID exist: Metal halide and high pressure sodium bulbs. Metal halide bulb emits light of the blue spectrum. This color of light is suitable for keeping plants compact and green leafy growth. It is the best substitute of the prime light source if natural sunlight is not available. The approximate lifespan of the lamp is ten thousand cumulative hours. High pressure sodium bulbs produce an orange-red glow. Wavelength of the light is

between 600 and 700 nanometers, and it increases plants' hormone levels and fuels the flowering. Fluorescent grow light is the third basic horticultural lighting system. It has better color rendering properties and it produces less heat, which enables these lights to be located closer to the plants. (Greenhouse guide).

One of the upcoming greenhouse lighting solutions is Light Emitting Diode (LED), whose biggest benefits are low energy consumption and long lamp life time. They also prevent insect pests and do not generate excess heat, so temperature damages can be avoided. However, the price of the LED and one light's efficiency are the biggest obstructive factors. A typical target area of the LED lights has been pilot light in electronic equipments. More powerful and brighter LEDs are used in buildings, bridges and also greenhouses. Nippon Keiki Kagoshima Works from Japan has researched red LEDs for several years, and in January 2007 they achieved 90 percent energy savings compared to normal lighting system in their six meters by fifty meters research greenhouse. (Energy Saving LEDs).

Carbon dioxide, also abbreviated CO<sub>2</sub> according to its chemical structure CO<sub>2</sub>, is a natural gas, which is dangerous for humans in high concentrations, but a lifeline for trees and plants. The air consists of nitrogen, oxygen and carbon dioxide. Trees convert CO<sub>2</sub>, water and light into glucose and oxygen during daytime. Carbon dioxide is a kind of fuel for the trees. It is also an important monitoring factor, which enhances the the growth of the plants. Sunshine and light increase the amount of carbon dioxide. During the summer, the greenhouse gets the needed CO<sub>2</sub> from natural air, when ventilation and roof windows are

open. This opportunity does not exist during the winter. In the following chapter three ways to produce carbon dioxide in a greenhouse are presented.

## 2.2 Greenhouse control

These days financially profitable greenhouses are fully automated. The producer can define the target values for the ideal growth environment and then, the system controls automatically each adjustment to keep indoor climate at the optimal level. Environmental monitoring and control can be divided into three tasks: Measuring, calculating and adjusting (Timmerman etc. 2003). These three tasks have their own functionalities, which are presented in Figure 2.

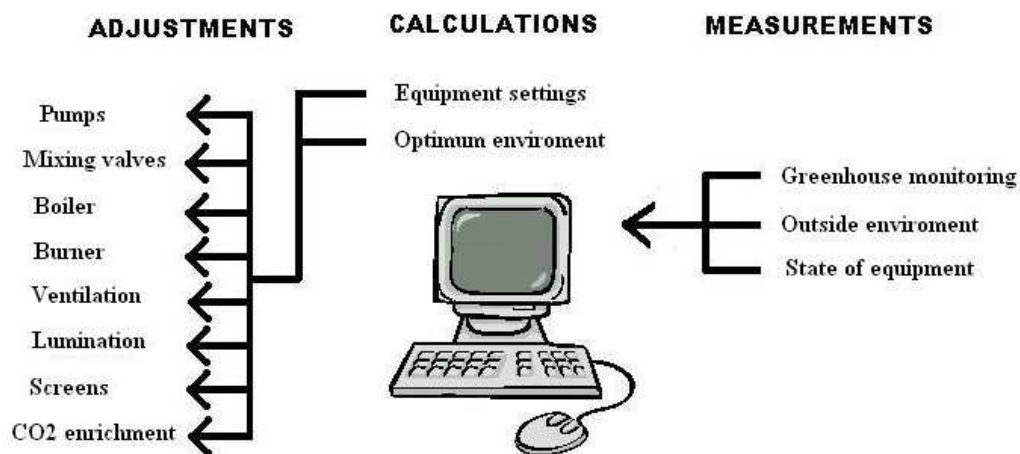
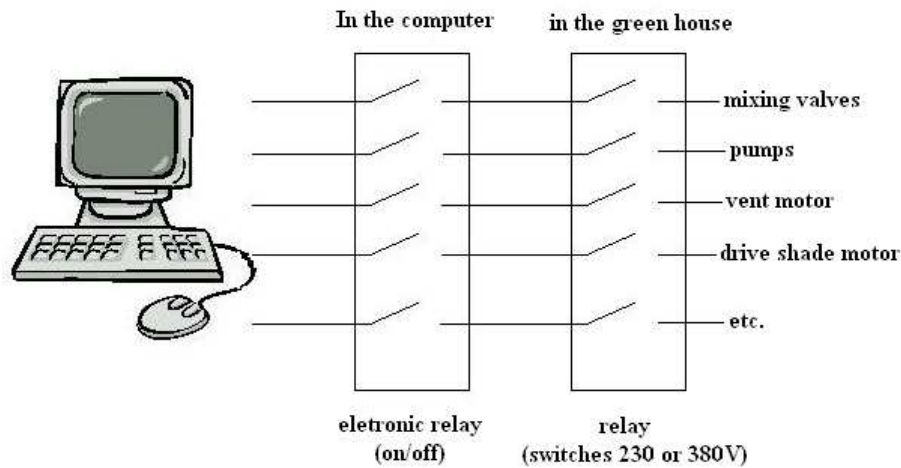

**Figure 2.** Tasks in greenhouse environmental control (Timmerman etc. 2003).

In the illustrated system, the incoming information from the climate of the greenhouse has been measured with sensors. The measurement signals are transferred to the computer, after conversion from analog to digital. Because of the high moisture, the computer is normally located outside the greenhouse. Signal provided by the sensors is normally weak. Without signal amplifier cabled sensors cannot get data through correctly. Wireless sensor network does not have such problems. Measured data can be sent directly to the gateway node which is plugged in the computer or via router nodes, if the distance between the measuring nodes and the computer exceeds the length of a single radiolink. Besides data collecting and control calculation, the computer also updates climate values and statistics on the screen for the grower. (Timmerman etc. 2003). This thesis concentrates on this part more carefully in Chapter 7.3.

The computer makes a control calculation for the correct adjustment in every 15-60 seconds. Greenhouse can consist of several parts that contain their own local and independent adjustments. As a consequence, also several measurement points are needed. Control output signals from the computer have low voltage (24 volts). Each output is connected to the electronic relay, which switches individually each equipment on or off through the second relay, which gives to the device the input voltage it needs (Timmerman etc. 2003). In Figure 3 is shown the control of the output signals with relays. Computer calculates intermediate time for the output signal and then determines how long each relay is turned on.

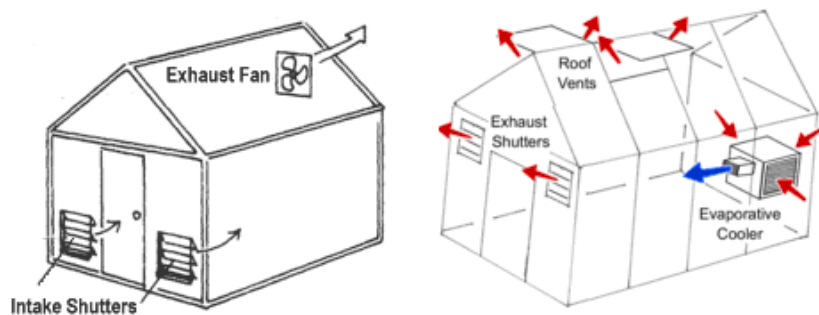



**Figure 3.** Output signals consist of an electronic relay (Timmerman etc. 2003).

Pipe heating is the basic central-heating system. Warm water temperature level inside the boiler is controlled by computer, which can provide the burner to meet the heat requirement. Hot boiler water is led to mains and heating circuits. Desired pipe temperature can be maintained by opening and closing the mixing valves in every couple of seconds. Cooled return water can decrease temperature level inside the heating circuits. Air heaters warm only the greenhouse air. Several heaters are placed all around the greenhouse for the purpose of equable climate. Heater blows fuel gases consisting of  $\text{CO}_2$  and  $\text{H}_2\text{O}$ , which are mixed with the greenhouse air. On one hand it is an easy way to increase the carbon dioxide concentration, but on the other hand it can upraise the level of these gases too high especially during cold periods.

With a good ventilation system the excess humidity and heat can be removed effectively. Such a system also influences water vapour and carbon dioxide concentration. Ventilation system design determines the air flow and exchange in the greenhouse. In addition, the common roof vents, evaporative cooler, intake/exhaust shutters and fans can be used. Figure 4 illustrates these basic ventilation solutions in greenhouses. If a crop is grown during the winter, accurate relative humidity control and a small ventilation capacity are desirable. On summer time, a large ventilation capacity is required. The computer runs the control algorithm, which exploits the environmental measurements and determines, how long each ventilation equipment is open or turned on.



**Figure 4.** Basic ventilation systems (Greenhouse Guide).

Three methods exist for the carbon dioxide enrichment: CO<sub>2</sub> burner, pure CO<sub>2</sub> and fuel gases from the boiler. Carbon dioxide burner acts as an air heater. A fan spreads heat and CO<sub>2</sub> into the greenhouse from the the combustion chamber. Alternatively, the producer can use pure CO<sub>2</sub>, which is manufactured by

industrial methods or collected from some industrial process to reduce the CO<sub>2</sub> emissions. Liquid gas is stored in pressurised cylinders and its supply does not depend on heat production. Controlling is easy with a solenoid valve switch, which can be turned on and off by computer. (Timmerman etc. 2003). The high cost is the biggest disadvantage in pure CO<sub>2</sub> use. Grower can produce more carbon dioxide by burning fossil fuel. Heating systems re-circulate gas into the greenhouse making double advantages for the producer. Also, it is a nature-saving way to deal with the unwanted greenhouse gases. When the burner uses natural gases, CO<sub>2</sub> can be recovered. Fuel gases emitted by the burner have a temperature at 200 °C, which is too high to be supplied directly. To overcome this problem, the gases are mixed with fresh air to reduce the temperature below 30 °C before supplying the gas to the greenhouse.

### **2.3 Wireless sensor network in greenhouses**

An efficient and productive greenhouse needs an accurate monitoring system. The Large size of the modern greenhouse has forced the producers to use several measurement points to track the changes in the greenhouse environment. Traditionally, many greenhouses include only one or two measurement spots, what is understandably in disharmony with accurate controlling up to 100 meters long greenhouse. When each measurement point needs its own wire, the costs and cabling work increase exponentially. Once the measurement spot has been built, it is tedious to be relocated. Impractical cables must step aside and wireless solutions fill their place.

Wireless sensor networks have gained ground in various industries. Agriculture and especially microclimate monitoring have many promising targets where the benefits of WSN can be exploited. Greenhouse grower can easily relocate the wireless sensor nodes in his greenhouse as long as the nodes are inside the communication range of the coordinator device. Installation work is unsubstantial compared to the cabling, and the large amounts of the wireless measurement points do not have remarkable effect on it. Wireless network maintaining is cheap and easy. The only additional costs occur when the sensor nodes run out of batteries and the batteries need to be replaced with new ones. The battery lifetime can be several years in efficient and power saving network. Greenhouse is one of the best places for the solar energy harvesting. Small sensor nodes can take a part of or even all the needed energy from the crystalline silicon solar cell (More information see Chapter 5.1). Greenhouse's moist climate and dense flora are similar to surroundings of the jungle. This kind of environment is challenging for the wireless system, whose communication range is better in open and normal humidity areas.

There are many wireless network research projects where wireless sensors are used successfully in greenhouses. The Rinnovando group is doing research work in a tomato greenhouse in the Southern of Italy. They are using Sensicast devices for the air temperature, relative humidity and soil temperature measurements with wireless sensor network. Additionally, the Rinnovando group has a web-based application for the plants monitoring. Greenhouse grower can follow the monitoring values of the climate through the internet and will instantly get alarm in the mobilephone by Short Message Service (SMS) or General Packet Radio

Service (GPRS) if some measurement variable changes rapidly. Main focus in this research is to get real time and reliable measurements from the microclimate of a tomato crop with wireless sensor network. (Mancuso & Bustaffa 2006).

The Rinnovando group has a test bed in a tomato greenhouse, whose size is 20 meter by 50 meter. Six nodes in two rows are employed 12,5m apart from one another. Distance between these two rows is approximately six and a half meters. Nodes locate in the bottom of the greenhouse in 0,25m height. Mesh node works as a repeater and improves the throughput of the communication. Bridge node is installed 40cm higher than measuring nodes for the same reason. It gathers data from other sensor nodes, which can send and receive packets with each other. Local Area Network (LAN) is connected between bridge node and base station (laptop computer) where data logging and computation happens. Figure 5 shows sensor node placement in the experiment. (Mancuso etc. 2006).

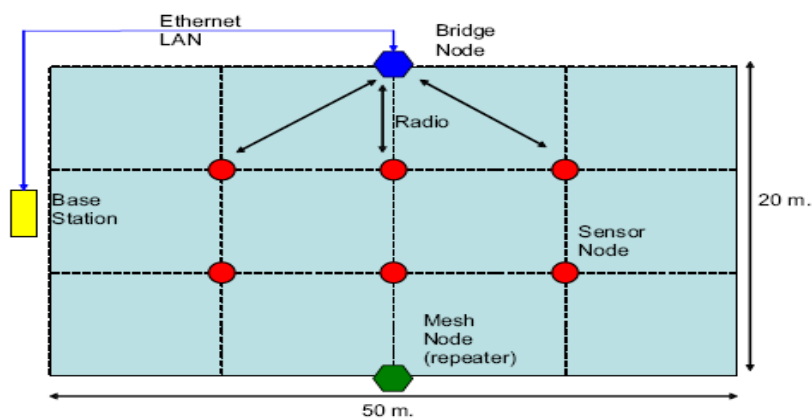

**Figure 5.** Sensor test bed in a tomato greenhouse (Mancuso etc. 2006).

Rinnovando group has built a wireless network with Sensicast's nodes. Basic Sensicast RTD204 node in Figure 6 transmits the relative humidity and temperature in one minute intervals. For these two measurement values a Sensirion SHT71 sensor (See detailed information about SHT71 sensor from Chapter 6.1.3 Proto sensor board) is modified to work with RTD204 and EMS200 router nodes. Four wired PT100 platinum waterproof sensors for the soil temperature can measure from 1 to 4 different spots from the soil. (Mancuso etc. 2006).



**Figure 6.** Sensicast RTD204 (Mancuso etc. 2006).

Sensicast nodes communicate with 2.4 GHz IEEE 802.15.4 radio. They have built their own protocol called SensiNet on the top of Low Rate Wireless Personal Area Network (LR -WPAN) standard. The main difference between SensiNet and ZigBee is Sensinet's new form of spread spectrum called Distributed Frequency Spread Spectrum (DFSS). DFSS is a combination of Direct Sequence Spread Spectrum (DSSS) used also by ZigBee, and Frequency Hopping Spread

Spectrum (FHSS). With FHSS ability, the Sensicast node changes the channel dynamically, which improves the reliability of radio transmissions in an extremely harsh environment, like in greenhouses. Figure 7 illustrates the benefits of the multiple channels. (Mancuso etc. 2006).

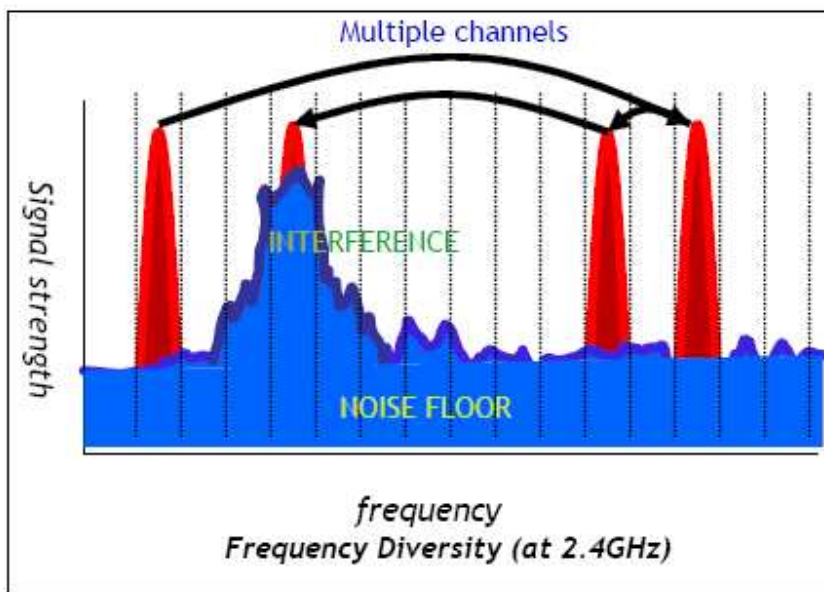

**Figure 7.** Example of DFSS (Mancuso etc. 2006).

Hui Liu and Shuanghu Cui from the China Agricultural University located in Beijing and Zhijun Meng from the National Engineering Research Center for Information Technology in Agriculture have published an article, “A Wireless Sensor Network Prototype for Environmental Monitoring in Greenhouses”, in spring 2007. The target of the research is develop and test their own WSN prototype inside the greenhouse collecting environmental data. They are using a

star topology network of Crossbow's MICAz sensor nodes. First, these nodes are active when reading temperature, humidity and soil moisture. Then, the readings are sent to the sink node in five-minute intervals. Sink node is composed of a MIB510 board with data terminal and MICAz node (More information about Berkeley's nodes and MICAz node in Chapter 5.2). Node programming and data receiving is possible through the Recommended Standard 232 (RS-232) serial interface provided by MIB510 board. Sink node locates far away from the greenhouse in a farm office where the central Personal Computer (PC) takes care of data logging and processing. The terminal with Advanced RISC Machine (ARM) processor module shows the latest measurements in a Liquid Crystal Display (LCD) inside the greenhouse and delivers data to the main PC by using Global System for Mobile Communications (GSM) module. The terminal framework is illustrated in Figure 8. (Liu, Meng & Cui 2007).

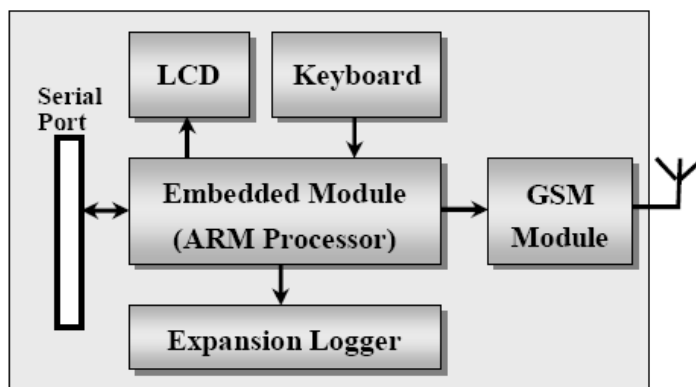

**Figure 8.** Terminal framework (Liu etc. 2007).



Demo farm monitors continuously spatial and temporal variations in temperature, humidity and soil moisture in the greenhouse. All data is gathered by sink node, which sends all information to the central PC. By comparing the Received Signal Strength Indicator (RSSI) values over the distance between nodes with different antenna heights and polarizations angle, it was possible to conclude that the longest communication range was achieved when nodes had the same orientation and maximal antenna height. Figure 9 shows one rudimental measurement, where two nodes measured eight hours temperature data. Node 2 was placed in the center of greenhouse and Node 3 is near the window. (Liu etc. 2007).

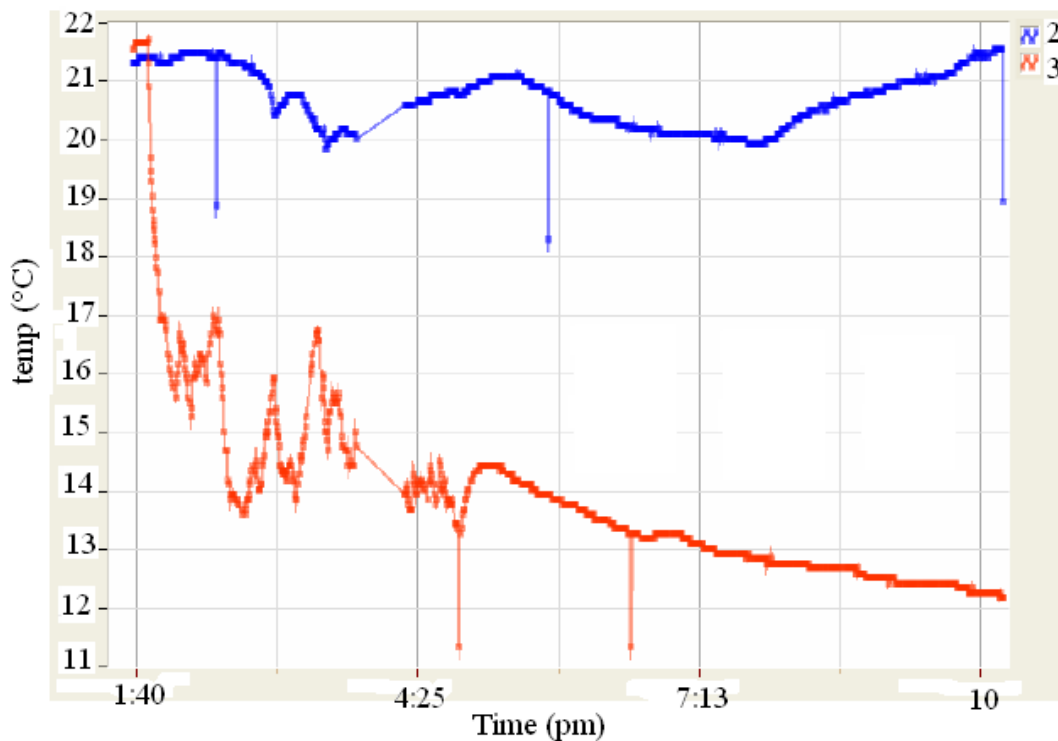

**Figure 9.** Temperature Readings from Two Nodes over 8 hours (Liu etc. 2007).

### **3 IEEE 802.15.4 WIRELESS SENSOR NETWORKS**

#### **3.1 Birth of the IEEE 802.15.4 standard**

The principle reason for developing IEEE 802.15.4 standard was a huge need to use sensors, monitoring and control devices in a wireless way. Earlier, cabling was the only solution and it still is the most used, even though wireless devices have gained some ground in the markets.

In January 1998 IEEE 802.15 Wireless Personal Area Network (WPAN) -working group was established to develop standard for the short range, low bit rate, low power consumption and low cost sensor networks. The standard was designed to be used with mobile network devices like laptops, palmtops, mobile phones, microphones and other electronic instruments. Functional requirements were part of the BodyLAN project and specific definitions, which were cheap price, low power consumption, low bit rate, small size, support for the network of 16 devices and simultaneous use with other wireless networks in the same area. These definitions were basis for design of WPAN family (Pahlavan & Krishnamurthy 2002).

IEEE 802.15 WPAN consists of four distinct work groups. The main aspects in research and development for group number four were simplicity, low price, low power consumption and light physical and Medium Access Control (MAC) layers (Pahlavan etc. 2002).

In the early phase of development the standard was splitted in two, because some characteristics of wireless sensors wanted to be formulated compatible with devices of different manufacturers. Two standards, IEEE 1451.5 Wireless Smart Transducer Interface and IEEE 802.15.4 Low Rate -Wireless Personal Area Network saw the daylight. (Callaway 2003)

The IEEE 802.15.4 standard, published in spring 2003, is meant for short range wireless communication. Its biggest difference with other IEEE 802.15 standards is low bit rate, which is the reason for Low Rate WPAN name. Low power consumption, cheap implementation, reliable data transfer and short range are also the main characteristics of the standard. Figure 10 presents a comparison between different wireless network standards in indoor range.

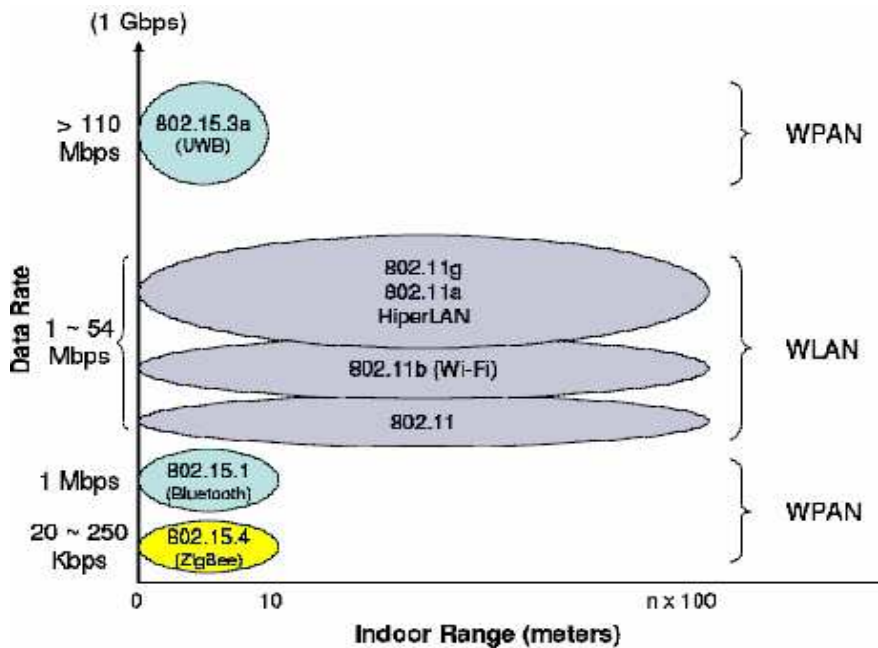
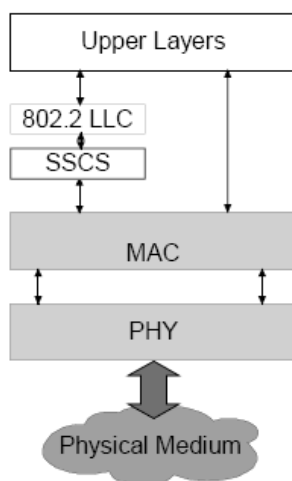

Figure 10. Wireless network standards (Zheng & Lee 2004).

### 3.2 Architecture

OSI seven-layer model constitutes the basis of the telecommunication protocols. IEEE 802.15.4 standard defines two lower layers, physical layer and MAC sublayer, which is a part of the Data Link layer. Actual data transfer with all functionalities is physical layer's task. MAC sublayer defines how to connect to the physical channel (IEEE 802.15.4 2003).

Upper layers of OSI model can be in contact with MAC sublayer in a direct way or through the Logical Link Control (LLC) and the Service Specific Convergence Sublayer (SSCS). Two different paths enable that either embedded devices or devices requiring the support of an external device, like a PC can be implemented in LR WPAN architecture. IEEE 802.15.4 device architecture is shown in Figure 11. (IEEE 802.15.4 2003).



**Figure 11.** LR-WPAN device architecture (IEEE 802.15.4 2003).

LR-WPAN standard defines three frequency areas. Lower band is 868 MHz and it is used in Europe. 915 MHz and 2.4 GHz frequency bands are so-called Industrial, Scientific and Medical (ISM) bands. The first one is used in Americas, except Greenland and those countries that specifically allow it, such as Australia and Israel. 2.4 GHz is used in most of the countries including also Europe. They are licence free and in place all around the world (Kinney 2003).

Maximum data rate depends on the used frequency area and applied modulation method. The lowest frequency area (868 MHz) has one channel and maximum data rate is 20 kbps. 915 MHz band includes 10 channels and it reaches up to 40 kbps speed. Both are using Binary Phase Shift Keying (BPSK) modulation method. 2.4 GHz frequency area has 16 channels and maximum data rate is 250 kbps. Modulation method is Offset Quadrature Phase-Shift Keying (O-QPSK). All three frequency bands use Direct Spread Sequence Spectrum (DSSS) technique. In Table 1 each frequency bands' features are presented. (Callaway, Gordon & Hester 2002).

**Table 1.** Frequency bands and data rates (IEEE 802.15.4 2003).

PHY (MHz)	Frequency band (MHz)	Spreading parameters		Data parameters		
		Chip rate (kchip/s)	Modulation	Bit rate (kb/s)	Symbol rate (ksymbol/s)	Symbols
868/915	868–868.6	300	BPSK	20	20	Binary
	902–928	600	BPSK	40	40	Binary
2450	2400–2483.5	2000	O-QPSK	250	62.5	16-ary Orthogonal

Standard does not define the transmission power in certain frequency areas, because transmission power is country specific. In Finland the biggest allowed transmission power is 25 mW for 868 MHz band. The maximum power of 2.4 GHz is 10 mW. (Viestintävirasto 2005). In 2005 Kangasvieri measured in his wireless sensor network research 101 meters range between two nodes in beneficial circumstances when the transmission power was 1 mW. Nodes communicated in 2.4 GHz frequency band. (Kangasniemi 2005).

### **3.3 LR-WPAN components**

Standard defines two node types with different features: Full Function Device (FFD) and Reduced Function Device (RFD). Full Function Device supports all characteristics of the standard and it includes all functionalities. It can serve as single central controller also called a Personal Area Network (PAN) coordinator, a coordinator or a normal device. FFD communicates with both device types. Reduced Function Devices do not have routing capability and they are acting as end points of the network, normally measuring some variables. Data processing capabilities are limited and devices send small amounts of data. One RFD device can be connected with one FFD device. (IEEE 802.15.4 2003), (Zheng etc. 2004).

Usually wireless sensor network contains a sink device, which can have more computing power and memory than normal device. It collects data from other nodes and controls and dominates the network. In many cases sink device is

connected to other networks and it serves as a gateway. This is why it is also called as the gateway node.

### **3.4 Topologies of wireless sensor networks**

The design of the network topology is one of the main elements to create efficient wireless sensor networks. Network size, the particular application, environment and demands made are criteria for chosen topology model. Power consumption is the most critical thing, because sensor node energy resources are very limited. LR-WPAN topology models do not differ so much from other wireless network topologies. Network topology can change when new device arrives to the network or the old ones are moving or switching off.

Figure 12 illustrates two different network topologies of LR-WPAN standard. In star topology network, devices communicate only with PAN coordinator. Devices are capable of communicating with each other in peer-to-peer topology. In other words, it is possible to build more complex networks by using peer-to-peer topology.

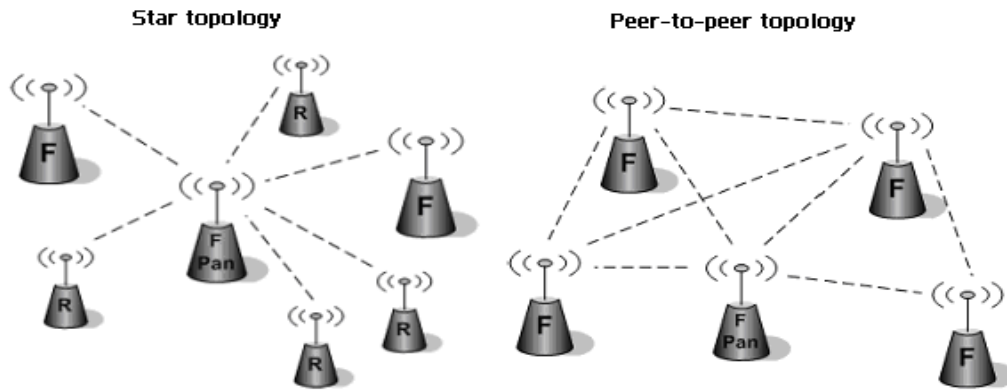

**Figure 12.** Star and peer-to-peer topologies (F Pan = PAN coordinator, F = FFD and R= RFD ).

Both networks configure themselves automatically with all devices which work in certain frequency band. Devices have their own unique 64 bits extended addresses. Device can communicate directly within the PAN using long address or it can have 16 bits short address which is given when device associates with the PAN coordinator. The size of the network dictates which address type is in use. (IEEE 802.15.4 2003).

The star topology can form full function device, when it will become also the PAN coordinator. It chooses unique PAN identifier for itself. After this, other FFDs and RFDs in same frequency band can join the network. (IEEE 802.15.4 2003).

In the peer-to-peer network devices can communicate with other devices within their communication range and in the same frequency band if they are full



function devices. Basically such a network forms one kind of ad hoc -network. Formation of the network begins when first full function device starts to act in certain frequency. It will then become the PAN coordinator and form the first cluster establishing itself as the Cluster Head (CLD). The PAN sets the cluster identifier (CID) to zero and starts broadcasting beacon message to neighbouring devices. Available full function and reduce function devices inside the range may request to join the network and the PAN coordinator can accept or deny the request. Joined FFD can form own cluster and become cluster head. The PAN marks this full function device as a child device to its neighbouring list. For the FFD, the PAN coordinator is parent of its neighboring list. After this, new CLD may broadcast beacon message in its range. Large networks can be built with this kind of process. In network formation, also mesh or token ring topologies may be used. Typically a sensor network having more than 10 devices is a mix of different topologies. When the network grows bigger, also latency and power consumption grows, which is a big drawback. The management and control of the sensor network becomes more difficult because of the same reason. Figure 13 illustrates an example of the cluster topology. (IEEE 802.15.4 2003).

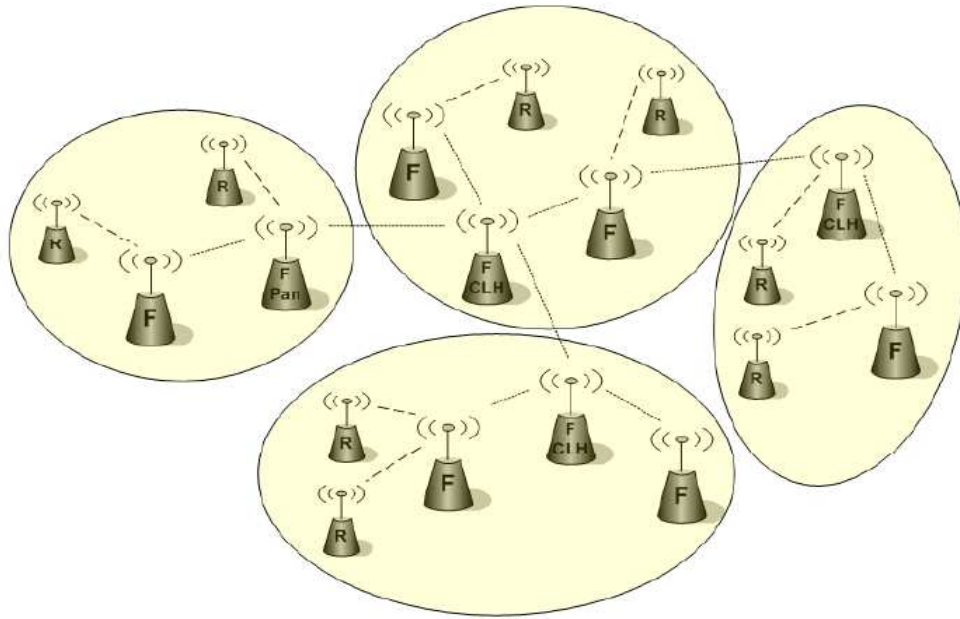

**Figure 13.** Cluster topology.

### 3.5 Data transfer and synchronizing of transmissions

Usually radio transceivers of devices are deactive most of the time in WSNs. In other words, they are in sleep mode and turned off. This is very important in power consumption point-of-view. Every device must be synchronized to act in a short time period in the right moment. Otherwise competition from radio channel may occur.

There are three models in transaction of data models. Data transfer from the coordinator to the device and vice versa is the star topology model. In peer-to-peer topology the device can in addition send data straight from one device to

another. IEEE 802.15.4 standard network can work in two modes: synchronization can be active (beacon-enabled) or deactive (non-beacon-enabled) mode. (IEEE 802.15.4 2003).

When the synchronization is disabled, the network devices can simply transmit data to the coordinator using unslotted Carrier Sense Multiple Access with Collision Avoidance (CSMA-CA). The coordinator has to store the data package to be sent. Then it waits until receiving side has sent data request. The coordinator can transmit data packet after it gets this request. (IEEE 802.15.4 2003).

The coordinator starts to send beacon message in according to certain interval, when synchronization is enabled. Other devices which belong to the sensor network can synchronize their own transmissions with beacons. Superframe structure is in use, which is showed in Figure 14.

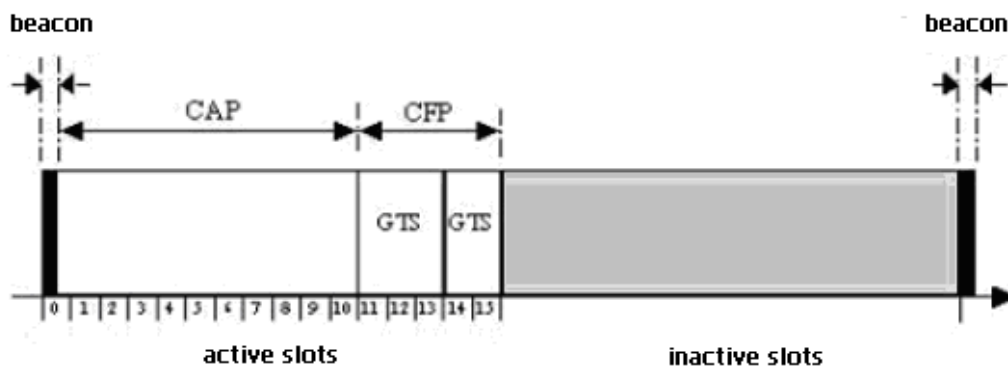
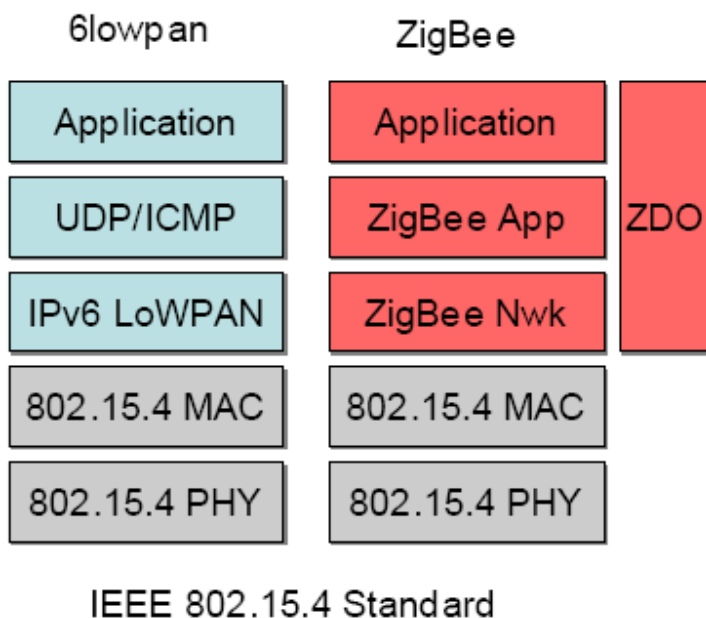

**Figure 14.** Superframe example.

Time slots for communication are defined in the superframe. The superframe consists of active part, which is divided into 16 equally sized slots and inactive part. In inactive part there is no functioning and the coordinator of network may enter low-power mode. The size of the superframe depends on the inactive period which can be between 15 ms and 245s. After the beacon has been sent, the sensor network devices may communicate during the contention access period (CAP) using slotted CSMA-CA mechanism. Devices must compete against each other to get slot from this period. If some device requires specific data bandwidth, it may allocate Contention Free Period (CFP) from the the PAN coordinator. Device must use Time Division Multiple Access (TDMA) mechanism to get one or more Guaranteed Time Slot (GTS). GFP can be from zero to seven slots long depending on the application. (IEEE 802.15.4 2003).

#### 4 ZIGBEE AND 6LoWPAN

LR-WPAN defines only two lower layers of OSI model: the Physical layer and the MAC sub-layer. The upper layers are left open for different kind of solutions. Two totally different networking solutions exist at the moment. Many manufacturers have made their own improved protocols from the ZigBee, which does not differ so much from the original one (For example Chapter 2.3 Sensicast's SensiNet protocol). Figure 15 illustrates how the ZigBee and IPv6 over Low power Wireless Personal Area Networks (6LoWPAN) use the IEEE 802.15.4 standard.



**Figure 15.** 6lowpan vs. ZigBee stack comparison (Sensinode 2008).

#### 4.1 Structure of the ZigBee and its features

ZigBee is built on top of IEEE 802.15.4 standard. It uses standard's functionalities and adds its own features. Figure 16 shows that ZigBee specification has developed to cover the network/link, security and application profile layers. The third party must consider application layer by himself. (Zigbee Alliance 2004).

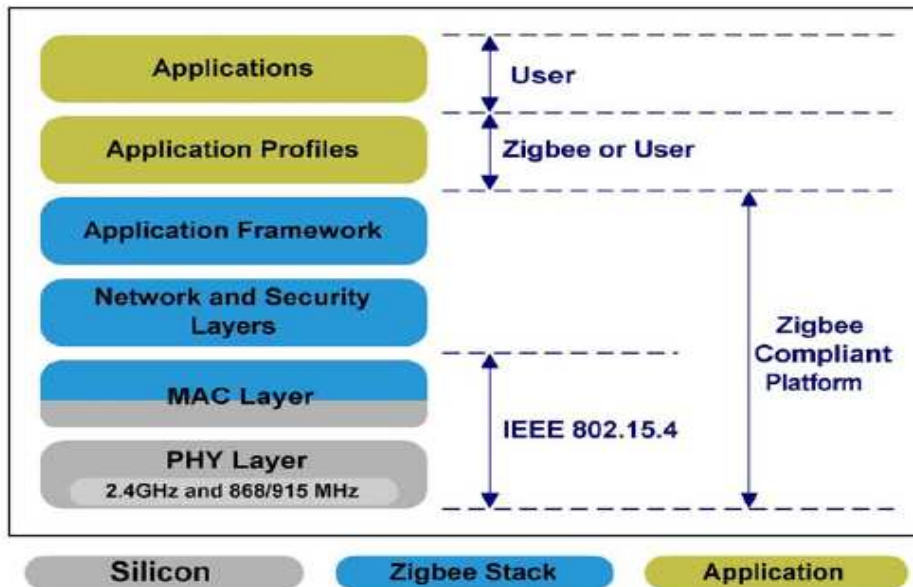

**Figure 16.** Architecture of IEEE 802.15.4 standard and ZigBee (Khanh 2005).

The ZigBee alliance is established in 2002. It is an alliance formed by hundreds of companies, having a task to develop long battery life, networking capabilities, reliability, and low cost wireless protocol for the measurement, monitoring and control devices. Customers can easily build their own applications on the top of

the protocol. The alliance member companies are mainly electronics and software houses. The name ZigBee comes from the way how bees fly zigzag while tracking between flowers and relaying information to other bees about where to find nutriment. ZigBee specification was ratified on 14th of December 2004 and version 1.0 was published on 27th of June in 2005. The specification is only open for the members of the alliance and non-profit used. (Stanislav & Kresimir 2006).

ZigBee's main tasks are: device discovery, network's establishment, distribution of addresses, service discovery and security of the transmission. (ZigBee alliance 2004).

In the device discovery, a node can send a request message by using its own 64 bits address or shorter, 16 bits network (NWK) address. Node's own address, also called the IEEE address is unicast and it assumes that NWK address is known. The NWK address request is broadcasted to all other network devices which are awake. 64 bits address is added to the payload of NWK address request. Response to the request depends on what type of device receives the message. The end point device responds with the IEEE or NWK address according to received address type. Full function ZigBee devices, the coordinator and the router, respond to the request and broadcast it to all other network devices within its range. (ZigBee alliance 2004).

Network establishment happens mainly in the same way as it is defined by IEEE 802.15.4 standard (Look topologies of the Figures 12 and 13). ZigBee brings only its detailed features for the network configuration. ZigBee router and the

network coordinator have the responsibility to distribute shorter 16 bits NWK addresses. The distribution follows the tree topology model, where the PAN coordinator is always on the top.

## 4.2 Binding

ZigBee network consists of devices with different tasks. To clarify, each device task inside the cluster binding is used in ZigBee network. Two or more devices with one another supporting functionalities can make connection links between each other. Binding could be done, for example, between an alarm clock and a coffee maker or like in Figure 17 between lamps and switches. Binding table stores all pairs inside the cluster. (ZigBee alliance 2004).

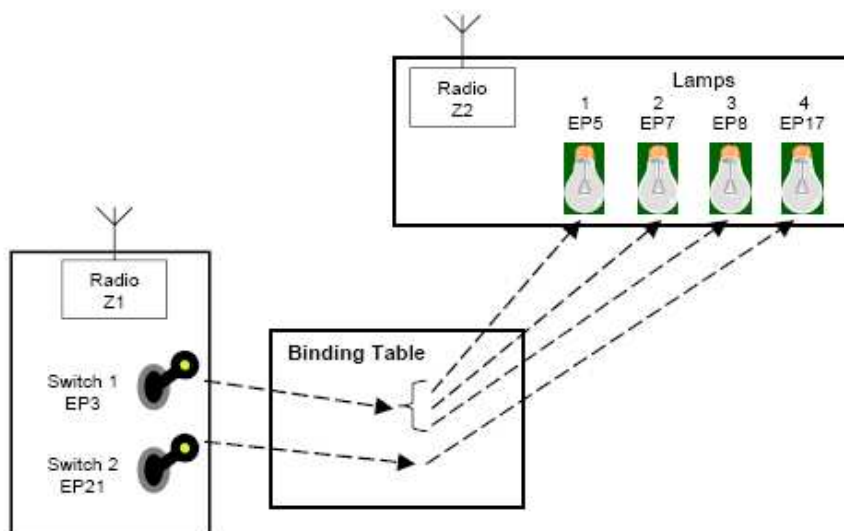

**Figure 17.** ZigBee binding and the binding table (ZigBee alliance 2004).



### 4.3 Security of transmission in ZigBee

Three security levels are defined for different applications. Transmission can be done without encryption, with Access Control List (ACL), which includes addresses of devices in the network. Or it can be done with ZigBee Advanced Encryption Standard (AES-128) encryption.

Encryption is splitted for three OSI layers, which are MAC, network and application layers. Each layer takes independently care own frame transmission as well as encryption. Three layers are using Counter with CBC-MAC (CCM), which is a generic authenticated encryption block cipher mode. It consists of two operations, Counter mode encryption and Cipher Block Chaining Message Authentication Code (CBC-MAC).

Counter operation divides data into 128 bits blocks. These blocks are operated one by one until their encryption counters are full. The actual encryption executes with AES-128. After all blocks are encrypted initial and encrypted data mix together with logical Exclusive OR (XOR) operation, which is a bitwise operator from binary mathematics. The decryption is a reverse operation for encryption. Decoded data is encrypted message in a place of real one.

In CBC-MAC operation methods are similar than in CTR, but encryption steps execute in different order. Outcome of the CBC-MAC encryption is 128 bits authenticate code, which receiver side can use to ensure the sender identification.

#### 4.4 6LoWPAN

6LoWPAN is an Internet Engineering Task Force (IETF) specification for transmission of compressed Internet Protocol version 6 (IPv6) packets over IEEE 802.15.4 networks. The standard IPv6 (40 bytes) and User Datagram Protocol (UDP) 8 bytes headers are too big for the 802.15.4 standard, which entire maximum transmission unit is only 127 bytes. Furthermore, the maximum Ipv6 packet size can be 1280 bytes long. It is needless to say that without compressing the Ipv6 packets can not be transmitted in WSNs. 6LoWPAN makes header 80 percent smaller making it ideal for use in wireless sensor network. Figure 18 shows how 6LoWPAN format is inserted into the IEEE 802.15.4 frame format. (Montenegro & Kushalnagar 2007), (Culler & Hui 2007).

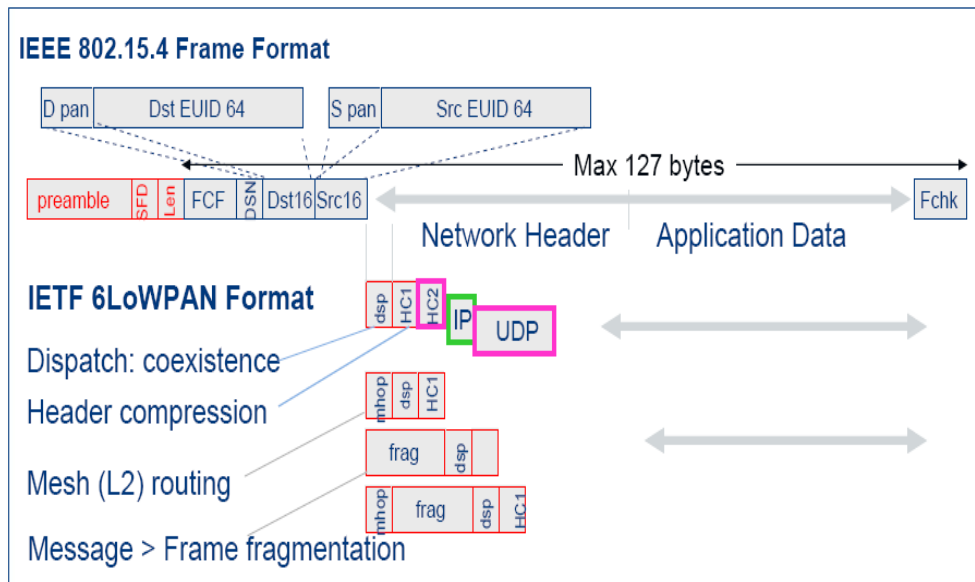

**Figure 18.** 6LoWPAN format design (Culler etc. 2007).

It can be seen from the Figure 18 how 6LoWPAN adds its own header after standard's one. First two bits of the dispatch (dsp) byte tell what kind of packet is coming. Table 2 shows the possible selection.

**Table 2.** Header type.

Byte:								Header type:
0	0	x	x	x	x	x	x	Not a LoWPAN frame
0	1	x	x	x	x	x	x	LoWPAN IPv6 addressing header
1	0	x	x	x	x	x	x	LoWPAN mesh header
1	1	x	x	x	x	x	x	LoWPAN fragmentation header

After the dispatch, 40 octets long IPv6 is compressed into two bytes (see header compression field HC1 and HC2 from the Figure 18). First two bits from the HC1 tell where IPv6 source address is carried. Next two bits, 2 and 3 illustrates where to find the destination address. Both IPv6 source and destination 64 bits addresses are link local. This means that source and destination can be inferred from the layer two addresses, because IPv6 addresses are made by layer number two. Both the Traffic Class and the Flow Label of the IPv6 header are set zero in bit 4. Bits 5 and 6 are shown in Table 3. They define the type of the next header. (Montenegro etc. 2007)

**Table 3.** Header type of the following packet.

Bits:		Next header type:
0	0	Not compressed
0	1	User Datagram Protocol (UDP)
1	0	Internet Control Message Protocol (ICMP)
1	1	Transmission Control Protocol (TCP)

The final bit 7 tells if there are more compressed headers coming. Normally 8 bits of HC2 (Figure 18) is a Hop Limit value, which always needs to be carried in full. UDP header is 8 bytes long and it can be compressed into 3 bytes, which includes source port 4 bits and destination port 4 bits.

#### 4.5 6LoWPAN in IPv4 network

The IPv6 network is still under development and current Internet users have to use Internet Protocol version 4 (IPv4) hosts. Some research predictions suppose IPv4 addresses will supersede by IPv6 sometime between 2011– 2013. 6LoWPAN does not work with IPv4 addresses, so it is impossible to use 6LoWPAN directly with existing infrastructure and IP networks. The sensor network can not deal with Network Address Translation (NAT), which is a part of the IPv4 address shortage. Also IP auto-configuration is missing from the current internet protocol version.

Some substitutive solutions are needed, if the 6LoWPAN would work with IPv4. C.-Y Yum, Y. Beam, S. Kang, Y. Lee and J. Song introduced three different

solutions how to IPv4 users can utilize 6LoWPAN techniques. (Yum, Beam, Kang, Lee & Song 2007).

In dual-stack method each node has two address versions, IPv4 and IPv6. The gateway device will route the packet depending on the type of the header. Figure 19 illustrates the method.

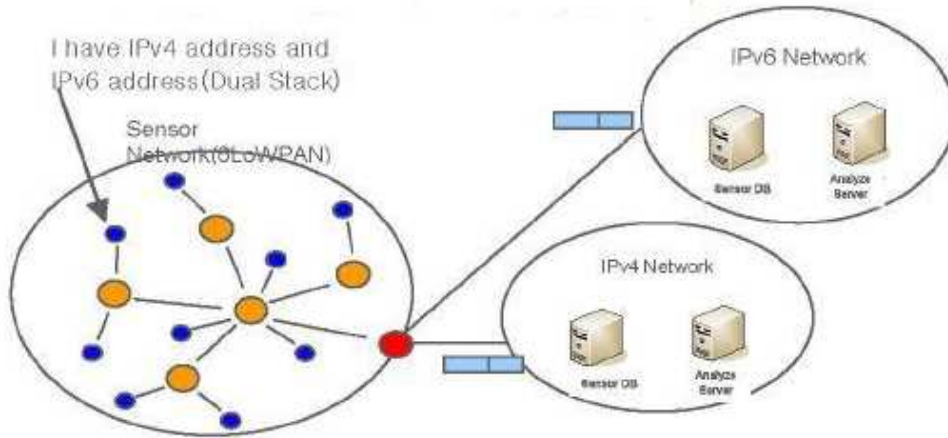

**Figure 19.** Dual-stack method (Yum etc. 2007).

The method has many weaknesses. The scarce resources of the existing sensor nodes make it unsuitable for sensor networks. In the near future amount of the sensor nodes will grow more rapidly than free IPv4 addresses are left. IPv6 can answer to this problem. Also new sensor network data format design must be done before the method can be used. (Yum etc. 2007).

Tunnel mechanism method borrows the dual-stack thinking, but only the gateway node is using it. The gateway node interconnects the packets between IP and sensor networks. IPv6 sensing packet is encapsulated by an IPv4 header in the tunnel and decapsulated in the IP node. The drawback is the overhead occurring in IP network. (Yum etc. 2007).

NAT was introduced a couple chapters before and it is one of the main reasons why 6LoWPAN does not work with IPv4 network. Last method focus on the problem by offering Network Address Translation-Protocol Translation (NAT-PT). It is on beside the gateway node and exchanges thr IPv6 header of sensing packet to IPv4 header. It is quite obvious that method is dealing with same problem than dual-stack. Pool of the IPv4 addresses is not enough for massive sensors. (Yum etc. 2007).

## 5 THE WIRELESS SENSOR NODES

The first wireless sensor nodes were made before the birth of IEEE 802.15.4 standard. The wireless sensor network paradigm was a myth from the late 1990s. US Defence Advanced Research Programs Agency (DARPA) was one of the driving forces in sensor networks research. Many early projects were focusing to blue-sky scenarios, where thousands of homogeneous nodes would have been localized by them selves and used mesh routing between each other. Smart Dust was one of the DARPA's earliest WSN projects, which goal was to demonstrate that a complete sensor with communication system can be integrated into a cubic millimeter package. The already ended Smart Dust gave birth to several further projects, which were countdown to development of wireless nodes.

### 5.1 Elements of the nodes

There are normally four basic components in wireless sensor node. Microcontroller ( $\mu\text{C}$ ) runs all functionalities and nowadays memory parts are integrated into  $\mu\text{C}$ :s in wireless sensor nodes. Transceiver is responsible for the wireless communication between nodes and different kinds of sensors make necessary measurements. Power source takes care of the nodes' supply.

Main processing units of embedded devices is microcontroller, which basically executes programs on the chip. Other running tasks are embedded system controlling, communication and measurement. Inputs/Outputs (I/O), peripherals

and both memories (Random Access Memory RAM and Read Only Memory ROM) are integrated into microcontroller chip to get cheap price and good power to performance ratio. Texas Instruments mixed signal  $\mu\text{C}$  MSP430 family board is presented in the Figure 20.

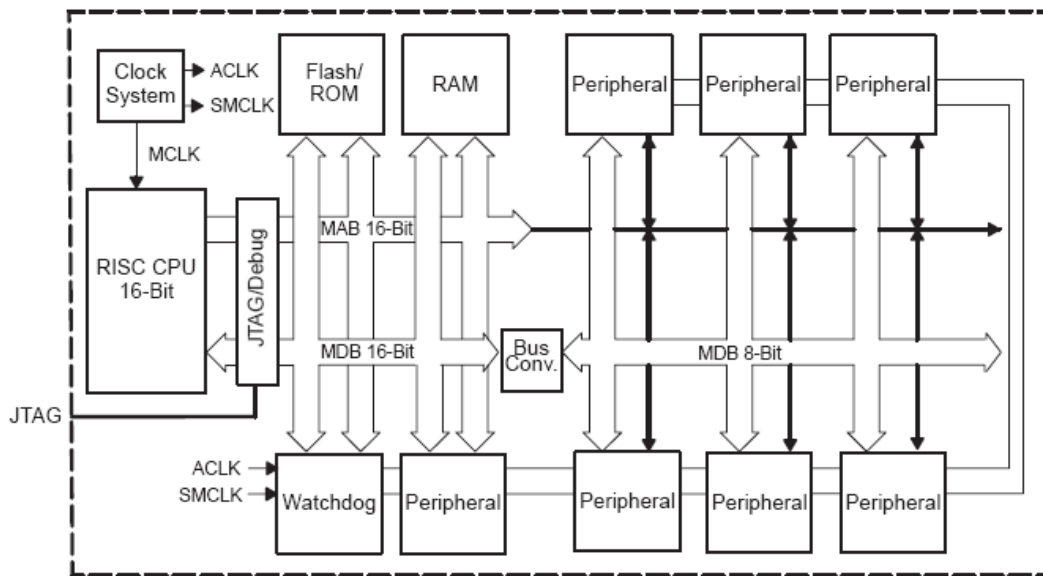

**Figure 20.** Block diagram from MSP430.

MSP430  $\mu\text{C}$  includes 16-bit Reduced Instruction Set Computer (RISC), which utilizes a small, highly-optimized set of instructions. ROM can have a size between 1-60 kilobits and RAM up to 10 kB according to the model of MSP430 family. Some of the Peripherals are given for the analog and the digital I/O:s. Analog I/O:s include 12 bits Analog-to-Digital Converters (ADC), Digital-to-Analog Converters (DAC) and a LCD driver. Two Universal Synchronous



Receiver/Transmitter (USART), Direct Memory Access (DMA) controller and Timers are added to the Digital I/O:s. Other common interfaces which are used with sensor nodes are Serial Peripheral Interface (SPI), Inter-Integrated Circuit (IIC) and Parallel bus. (Texas Instrument 2006).

The radio part ables the sensor nodes to communicate wirelessly. Modern embedded communications chip combine half-duplex transmission and reception. These chips are called transceivers. There are integrated analog interface, the whole digital baseband and key MAC functions in the transceiver chip. Two of the most important characteristics of the transceiver are power consumption and efficiency. Data transmission must happen fast and all other time should transceiver stay in sleep mode. Other typical characteristics are high level of digital integration, error coding capabilities, modulation, receiver sensitivity and support for upper layers. Figure 21 shows a block diagram of commonly used CC2420 transceiver, which is a Chipcon product from Texas Instruments. It has IEEE802.15.4 compliant radio and it works in 2.4GHz frequency, which gives to 250 kbps maximum datarate. Some useful characteristics are energy detection (Received Signal Strength Indicator RSSI), retransmission (CSMA) and security (authentication and encryption).It has very low energy consumption. In sleep mode node spend only 20  $\mu$ A and idle mode 426  $\mu$ A. Transmission burn off current is 8.5-17.4 mA and receiveing current 18.8 mA. (Chipcon 2004).

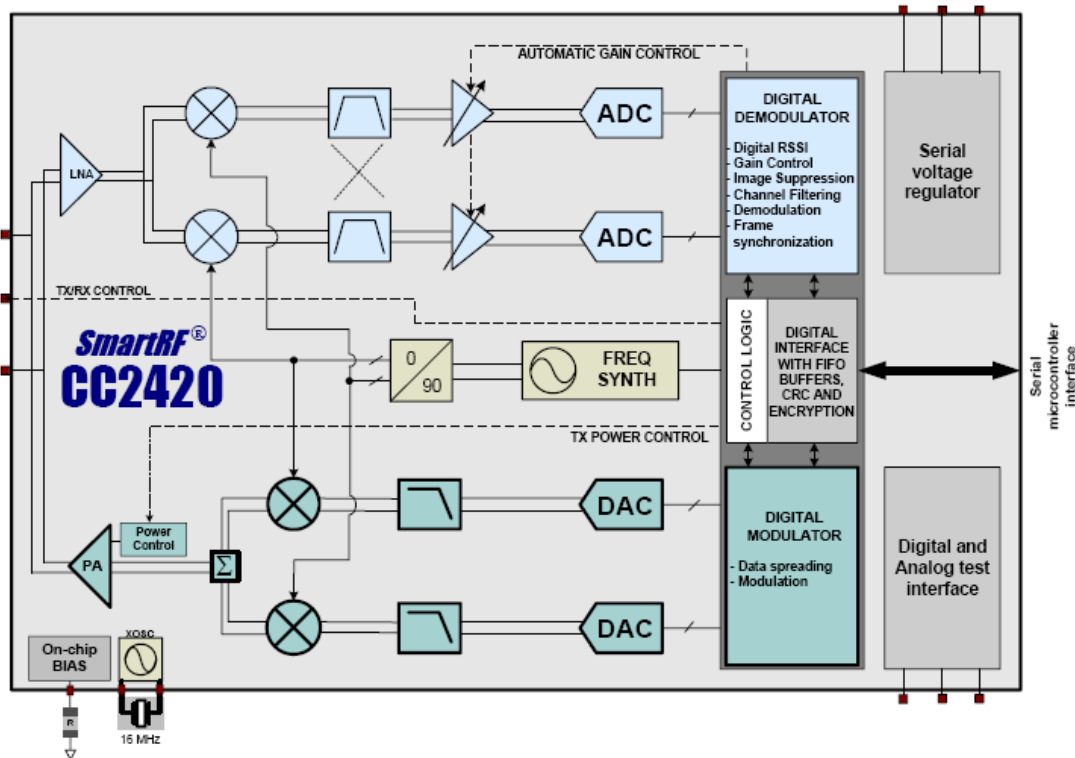

**Figure 21.** CC2420 transceiver block diagram.

Tiny sensors can measure many different things in the same node. Actual measuring needs depends on the application, but typical measurement factors are temperature, luminosity, pressure, humidity, distance, acceleration and magnetism. Also human interface can be a sensor, for example button. Target of the sensor application defines which sensors are needed. Only limits for use of the sensors are significant energy consumption, size and the wake up time to perform the measuring.

Size of the memories and computing power of the microprocessor have multiplied over the last decade. Research of the energy sources drag behind

much slower. Normally micro-electronic nodes get their power from the batteries. The longer the battery can give current to the node the longer the life time of the sensor node is. The node can use also a renewable energy source. Energy harvesting is the process by which the energy is captured from the environment and stored. A variety of different methods exist for energy harvesting, such as solar power, piezoelectricity, thermoelectricity and physical motion. Solar power is the best-known energy harvesting methods. It is very efficient compared to most of the other harvesting methods. Still ambient light have many problems mainly caused by lack of light, for example at indoor usage. The energy conversion efficiency of crystalline silicon solar cell modules is normally under 20 percent and closer to 10 percent for flexible amorphous silicon panels. (Paradiso & Starner 2005), (Vijay, Kansal, Hsu, Friedman & Mani 2005).

## **5.2 Berkeley Motes**

The University of California at Berkeley has been a forerunner of the wireless sensors platforms. First generation came to the market over 9 years ago. Wireless sensor platforms called “motes” have changed during the years, but the same basic elements which can be found from the earliest motes, can also be found the newest ones. Microcontroller computation power and memory size has grown fast simultaneously when the prices of both components have decreased. Channel encryption and authentication have improved the security of the wireless sensor networks. (Berkeley Motes).

First Berkeley mote called RF mote introduced in year 1999. It uses an Atmel 8 bit AT90LS8535 microcontroller (Atmel AVR AT90LS8535), which has 8 kB flash memory and 512 bits EEPROM. RF Monolithics 916 MHz transceiver's average data rate is 7.8 kbps and the communication range extends to 30 meters. Mote consists of five sensors which are showed in Figure 22 with details. The RF mote's powersource is a 3 V lithium coin cell battery which can keep the mote alive for 5 days of continuous operation or 1.5 years at a duty cycle of 1%. (Berkeley Motes).

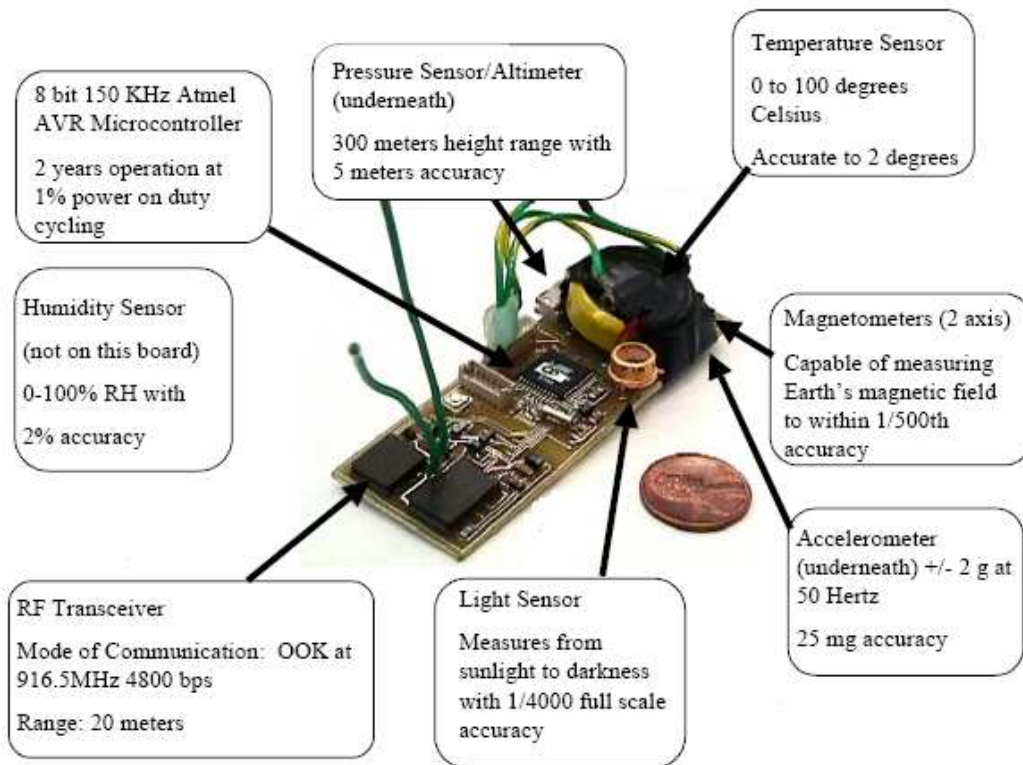

**Figure 22.** RF mote.

The mini motes are basically offsprings of the RF motes. First Mini mote (See Figure 23 Node on the left) has built around AT90S2313 microcontroller (Atmel

AT90S2313 datasheet), which includes a CPU clock of 4 MHz, 2 kB flash memory and 128 bytes RAM. Tiny board (1cm\*1cm\*5cm) consist of one temperature sensor. WeC mote (See Figure 23 node on the right) was the second version of the mini motes. It is a little bit bigger than predecessor Mini mote, but it has a number of additions. With integrated Print Circuit Board (PCB) antenna and 916 MHz RFM TR 1000 RF Transceiver (RFM TR 1000 RF transceiver datasheet), communication range reach up 4-6 meters. It uses same processor than Mini mote and it has a light and a temperature sensor on-board. The most significant advantage in this mote is the support for the reprogrammable over a wireless link, when earlier the reprogramming happens via cable. (Berkeley Motes).

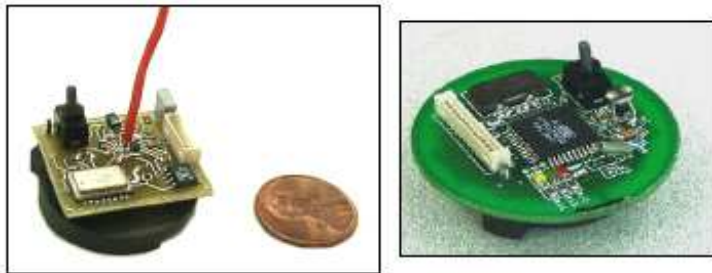

**Figure 23.** Mini and WeC motes (Berkeley Motes).

Fourth generation Mica mote saw daylight in 2001. Before Mica mote two other motes were designed at UC Berkeley, Rene and Dot motes. Since 2000 has Crossbow manufactured all motes and they have been commercially available. Mica mote consists Atmel ATMEGA103 4 MHz 8 bit microprocessor, which has 128 kB instruction memory and 4 kB RAM. Comparing to the earlier motes the

Mica can turn off its RFM TR1000 916 Mhz radio, which is efficient way to save power. Communication range extends to 30m and the raw data rate is 19.2 kbps. External peripherals can be easily plugged in to the board by using a 51-pin connector, which is compatible with analogue input, IIC, SPI, UART interfaces and a multiplexed address-data bus. Figure 24 presents a block diagram of the Mica board. (Berkeley Motes).

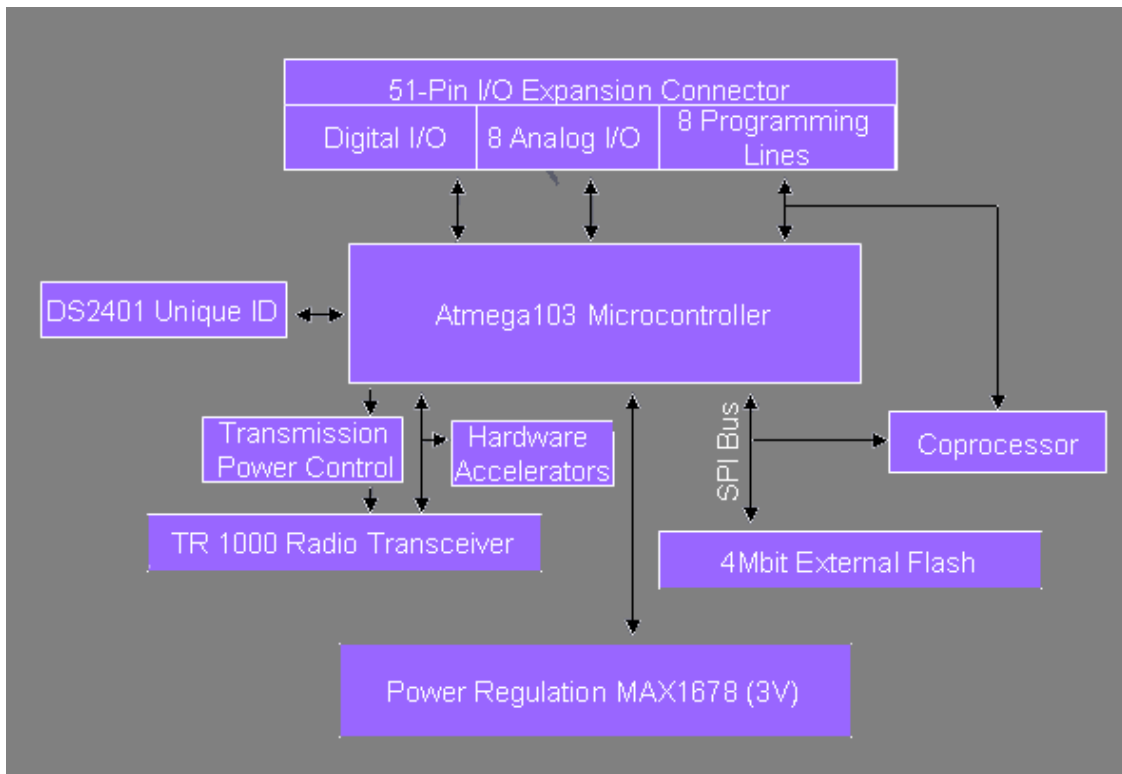

**Figure 24** Block diagram of the Mica mote.

Mica2 and Mica2Dot motes followed-on to the popular Mica series adding couple improvements. Both have a Chipcon CC1000 radio transceiver (Chipcon

2002), which operates either on the 433 or on the 916 MHz bands. The radio signal is FM modulated and the maximum communication range reaches up to 150 meters in outdoor environment in good circumstances. Mica2 uses the same 51-pin connector and microcontroller than the earlier version. The  $\mu$ C has an increased clock speed of 7.3827 MHz. Mica2Dot mote is a circular board having a diameter of 1 cm. Small size and circle shape forced the Mica2Dot designers place 19 serial pins around the circumference of the chip. These pins are defined for power, ground, power control, ADC channels, some general purpose digital IO, and the serial programming port. In 2004 last Mica product, MicaZ mote came to the market. It has identical features with Mica2 mote except the IEEE 802.15.4 radio transceiver, which operates 2.4 GHz frequency area and has a maximum data rate of 250 kbps. In ideal conditions, each Mica series platform can live approximately one year with 2 AA batteries being continuously in the operating mode. Figure 25 Shows Mica2 and Mica2Dot motes. (Berkeley Motes).

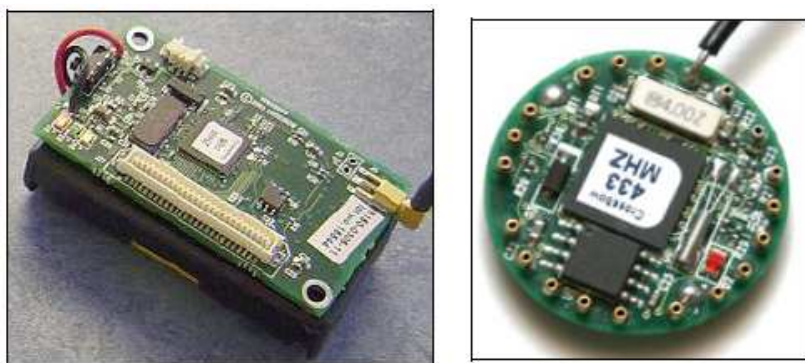

**Figure 25.** Mica2 and Mica2Dot motes.

The Spec mote is a fully working single chip mote which has a RISC core and 3 kB of memory. The size of the chip is incredible 2 mm by 2.5 mm. Spec uses radio communication on the 902.4 MHz band. In research tests Spec has been proven to communicate over 12 meters indoors with a data rate of 19.2 kbps. Chip also consists of a temperature sensor and an A/D converter. Spec mote compactness is shown well in Figure 26, where it is beside the head of the pen. (Berkeley Motes).



**Figure 26.** The Spec mote (2 mm \* 2,5 mm).

### 5.3 ZigBee radio nodes

After IEEE 802.15.4 standard and ZigBee revival most of the node manufactures utilize LR-WPAN radio transceivers with 2.4 GHz frequency. The size of the memories and microprocessor calculation power differ from each other. Normally platform consists of serial pins for the communication with the sensor



and other peripheral interfaces. Many boards have integrated sensors which are simply configured to use. Nodes consume small amount of power and they have different energy-saving modes, where power can be turned off from different parts of the platforms. Table 4 introduces four nodes from different producers. In power consumption mode some radical differences can be seen even though they all are using ZigBee 2.4 GHz radio transceivers. The microprocessor clock speed is one influential factor to the energy saving.

**Table 4.** Four ZigBee radio nodes.

<b>NODE</b>	<b>Telos Mote</b>	<b>XYZ Sensor</b>	<b>ZMN2430HP</b>	<b>CC2510Fx</b>
<b>CPU producer</b>	Texas Instruments	OKI/ARM	Intel	Intel
<b>CPU Model</b>	MSP430	ML67Q5002	8051	8051
<b>CPU Clock (MHz)</b>	8	57,6	8	8
<b>RAM (KB)</b>	10	32	4	4
<b>SRAM (KB)</b>	48	256	32	32
<b>Sleep mode(<math>\mu</math>A)</b>	15	30	3	1
<b>Active mode(mA)</b>	3	43	20	17
<b>Tx mode(mA)</b>	35	60	133	22
<b>Rx mode(mA)</b>	38	63	33	23

## **6 APPLIED SENSOR NODES**

In my Master of Science thesis I concentrate on building a wireless sensor network for the greenhouse monitoring. Star topology network is made with Sensinode's wireless sensing platforms based on pioneering 6LoWPAN (More information in Chapter 4.4) IP-based technology.

Sensinode LTD. is a rapidly growing three years old startup based in Oulu, Finland. The company is already a leader in IP-based wireless sensor networks. They believe that the combination of 802.15.4 and IPv6 will be a huge success that has the potential to become the WiFi of the embedded world (Shelby 2008). Sensinode has made its own flexible and open source 6LoWPAN protocol stack called NanoStack (See Chapter 6.4. NanoStack) for wireless, low power devices.

### **6.1 Sensinode's sensing platforms**

Sensinode has two product series on sale, Micro and Nano Series. Both node families support NanoStack and its functionalities. Older Micro Series is more suitable for research and development use with plug-and-play modules. Therefore, the testbed of four measuring nodes in the greenhouse is established by using two Micro node products, own sensor board and NanoStack. (Sensinode 2007).

### 6.1.1 U100 Micro.2420

Micro.2420 is the core device of the Micro series. It is a completely operational Full Function Device with accessible connectors for the sensor and user interface element operation. U100 needs bus-supplied 3.3V power or two NiMH batteries. Normally this standalone communication node runs on two AAA-size batteries, whose minimum voltages are 1.5V. Texas Instrument's MSP430 microcontroller and Chipcon's CC2420 802.15.4 radio are integrated on the U100 board (Look detailed information about MSP430 and CC2420 from Chapter 5.1). Microcontroller is working at 8 MHz with 10 kB RAM and 48 kB Flash memory. CC2420 RF-transceiver's maximum data rate is 250 kbps and it has its own 4Mbit serial data Flash memory. Modular architecture enables adding other Micro modules, and through the eight digital/analogue IOs own sensors and actuators can be plugged. The sleep mode current is under 50  $\mu$ A and the operating current (in RX and TX modes) under 25 mA. In Figure 27 Micro.2420 node is shown. (Sensinode 2006a).

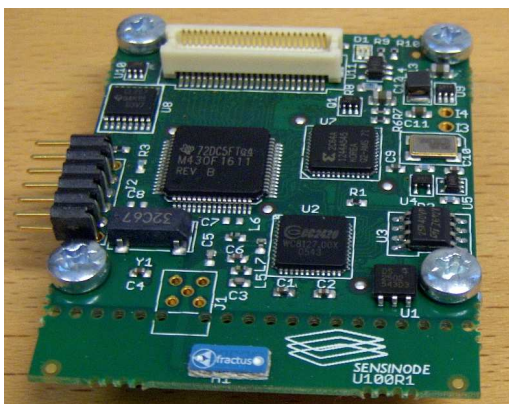

**Figure 27.** U100 Micro.2420.

### 6.1.2 Micro.usb U600

The Micro.usb module U100 works as an interface between the U100 node and, for example, a PC. Module gives a serial connection over Universal Serial Bus (USB) with widely supported Future Technology Devices International (FTDI) USB chip for data transferring and debugging. It also enables the microcontroller programming and supplies power to the stack. U600 can be used with rechargeable batteries. When USB cable is connected, batteries are automatically charged. U600 module can only be plugged into U100 communication node (Sensinode 2006a). Functional diagram of Micro.usb and the module itself are presented in Figure 28.

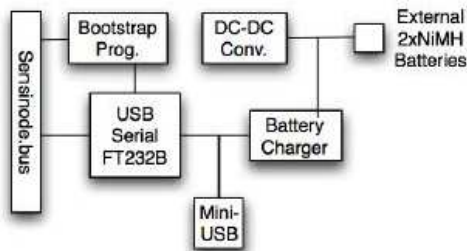

**Figure 28.** Functional diagram of the Micro.usb U600 and a stack hierarchy of module and U100 node.

### 6.1.3 Proto sensor board

Four nodes have their Proto sensor boards equipped with irradiance, temperature and humidity sensors. This is shown in Figure 29 Carbon dioxide sensor has special requirements for the input voltage and the response time. Because of this, it is not compatible with other sensors with low power consumption and fast measurement time. Two more devices are equipped with CO<sub>2</sub> sensors and external 5V power source.

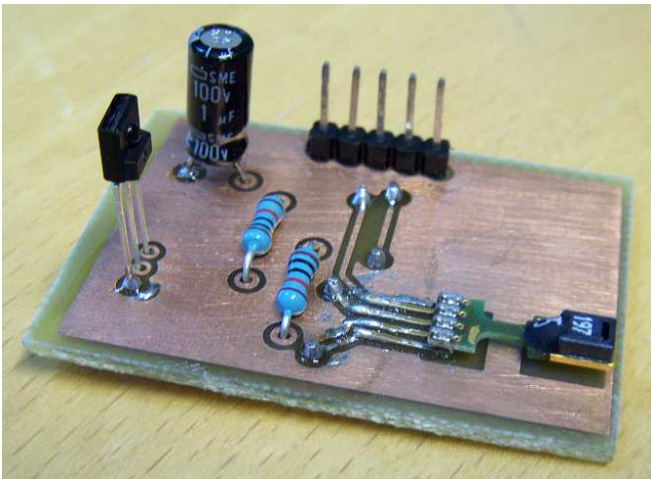

**Figure 29.** Proto board with irradiance and temperature/humidity sensors.

Fast response time, low power consumption and endurance against moist climate make SHT75 relative humidity and temperature sensor (on the right in Figure 29) a perfect solution for the challenge in this greenhouse project. Temperature accuracy of the sensor is  $\pm 0.3$  °C and relative humidity accuracy

under  $\pm 2\%$ . Communication between SHT75 sensor and node is similar to IIC interface developed by Philips. Data and clock line are the same in both cases, but SHT75 has only one pull-up resistor between data and power supply line. Two I/O pins act as data and clock line terminals. Running software in the wireless device reproduces the communication between sensor and node by pulling up and down voltage level (0V = down, 3.3V = up). Figure 30 illustrates the relative humidity measurement. (Sensirion 2007).

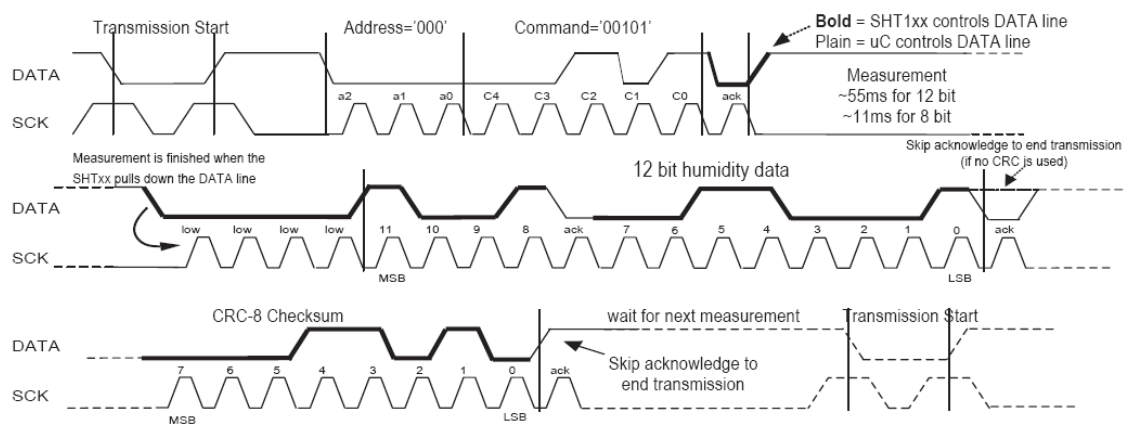
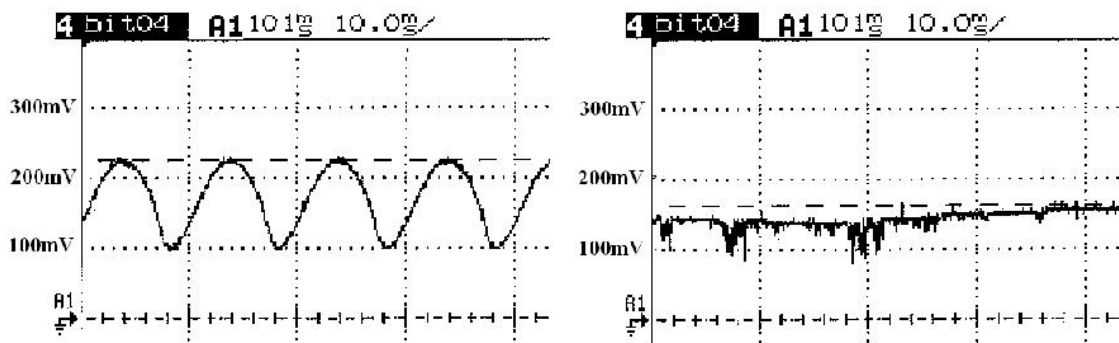

**Figure 30.** SHT75 Relative humidity measurement example (Sensirion 2007).

“Transmission start” sequence initiates the transmission and it is the wake-up sign for the sensor. The subsequent command byte includes three address bits (always 000) and the five command bits, ‘3’ (00011) for temperature and ‘5’ (0101) for the humidity. SHT75 indicates the correct reception of commands by pulling data line down as an acknowledged bit. After this, the data line is released (goes up) during the measuring. Measuring time is 55 ms for the 12bit humidity and 210 ms for the 14bit temperature response. After the readings,

sensor transmits two bytes of measurement data and one optional byte Cyclic Redundancy Check (CRC) checksum. Transmitted values are Most Significant Bit (MSB) first, right justified. The SHT75 automatically returns to sleep mode after the measurement and communication has ended. (Sensirion 2007).

Irradiance is measured by TAOS TSL262R (on left in Figure 29), which converts the light intensity to voltage (Texas Advanced Optoelectronic Solutions Inc. 2003). Unstable output signal is handled by low-pass filter to get correct irradiance values. Despite the simple model of RC-low-pass filter, the output result is good and easily readable. Figure 31 illustrates output voltage level made by oscilloscope before and after the use of low-pass filter.



**Figure 31.** Output voltage before and after the use of low-pass filter.

Figaro's TGS4161 carbon dioxide sensor was one of the alternatives, which was the most compatible with low voltage sensor node. CO<sub>2</sub> measuring needs longer time than other sensor types and the voltage supply must be  $\pm 0.1V$  from the 5V voltage. The carbon dioxide value can be read from the output voltage.

Operation amplifier raises the voltage level of otherwise weak signal from the sensor (Figaro Engineering Inc. 2003). In addition, filter must be used to get more stable output voltage. Proto board with Figaro's carbon dioxide sensor will be taken within the wireless sensor network in the future (See more information from the Chapter 9).

## **6.2 Nanostack**

Nanostack offers a flexible way to use 6LoWPAN protocol stack and a full IEEE 802.15.4 implementation. It includes 6LoWPAN IPv6 and UDP implementations, Internet Control Message Protocol (ICMP), IEEE 802.15.4 MAC, nRoute and Simple Sensor Interface (SSI) sensor protocols. Own custom protocol can easily be added to Nanostack as protocol elements, which are shown in Figure 32. Besides a basic star topology, the protocol also supports Nanomesh multihop network up to 2-3 hops. An open-source Real Time Operating System, FreeRTOS runs in the background of the Nanostack. Applications communicate with stack through the socket interface, which is familiar in the client-server, computer communications world. It is widely used in Portable Operating System Interface (POSIX) compliant systems. Nanostack operates open source tools (gcc, make, sdcc etc.) and it supports both Linux and Windows (Gygwin) development environments. (Sensinode 2008).



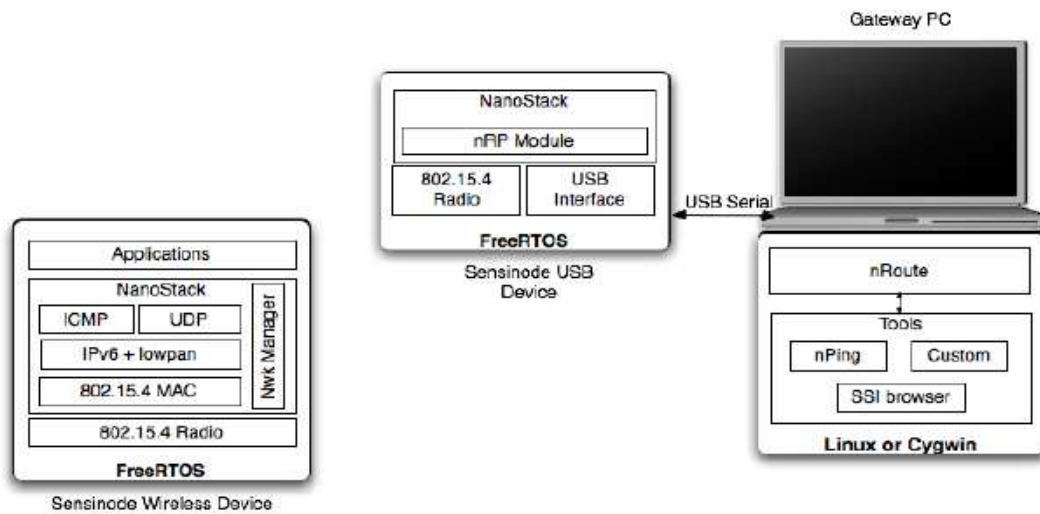

**Figure 32.** Components of the Nanostack architecture (Sensinode 2008).

### 6.2.1 nRoute Protocol and daemon

The communication between a node and a PC over the USB serial port is carried through by nRouted Protocol (nRP). The protocol enables data transfer and basic RF configuration. In addition, protocol fields have a free space for their own new address types and configuration options (Sensinode 2006b). In Figure 32 nRP is included in nRoute, which is a multi threaded daemon. It offers a simple user interface to the sensor nodes by using a certain gateway node. The daemon sets up a concurrent Transmission Control Protocol (TCP) server operating in a specified port. After this remote or local application can send or receive data and configuration packets between the nodes. When client application wants to receive data from the sensor nodes, it must first send a nRP nRoute configuration

packet. nRP Packet consists of all information for nRouted in order to be able to determine, which packets the application wants to receive (Sensinode 2008).

### 6.2.2 SSI protocol

Simple Sensor Interface (SSI) protocol is a generic communication protocol for discovering and accessing sensors within a sensor network. It provides data transferring between user terminal, such as computer and wireless sensors. Nokia, Vaisala, Suunto, Ionific, and Mermit – big Finnish companies and University of Oulu have jointly been designing SSI protocol (Hyyryläinen & Jantunen 2005). It is developed within MIMOSA project (MICROsystems platform for MOBILE Services and Applications), whose criteria were: general purpose, simple – minimal overhead and small memory footprint on the server (sensor). SSI protocol has two alternatives: point-to-point, where the protocol operates over a serial link Universal Asynchronous Receiver/Transmitter (UART) connection, and networking (nanoIP) application. NanoStack is based on networking SSI model, whose UDP message format is illustrated in Figure 33 (Hyyryläinen et al. 2005).

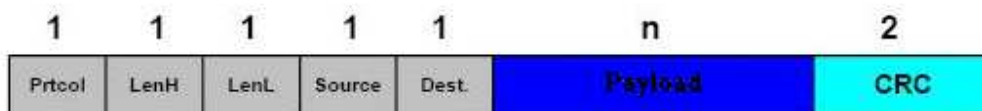

**Figure 33.** SSI nanoUDP message format (Hyyryläinen et al. 2005).

A 5-byte nanoUDP message header consists of one protocol byte, 2-byte message length, one byte source and destination port numbers. Both port numbers are 40 (0x28) when a node sends a packet. Payload size is not defined, but the first byte of the payload must be an address field and the second byte command field. Address field is used to separate multiple sensors on a single communication node. Wildcard address is defined to be '?' (0x3F) with the "Query" command. One byte long command field has 255 different alternatives, but only 18 commands are defined for the SSI protocol. Six of the commands are always used to the data sent from the terminal to the sensor nodes, and five commands are needed for the responding. The rest of the payload depends on the command. Last two bytes of the nanoUDP packet are reserved for the optional CRC checksum. (Hyyryläinen etc. 2005).

### 6.3 Software

Measuring sensor nodes as well as the gateway node, which gathers data from the wireless nodes to PC application, need their own software. The gateway device operates with Sensinode's `micro_usb_u600` application, which provides UART access to radio for the nRoute running on the PC. Basically, it is simple software allowing the PC tool to transmit and receive 802.15.4 MAC packets. After the initialization, sensor node application runs forever until its batteries are empty. Energy saving is maximized by setting long sleep mode periods to the application. Sensor data collector, the PC tool application, controls whole star topology network. It defines when each sensor node will be in active mode

reading and sending measurements. Sensor data collector shows the upcoming data in real time and saves the measurements with time stamps.

Applications are based on C programming language. The codes of the applications are made by using normal text editor tool. GNU Compiler Collection (GCC) is the most common cross compiler and it is used to create binary files. After compilation, binary files are uploaded by msp430-bsl programmer for Micro platform devices. Real-time debugging is possible with msp430-jtag.

### **6.3.1 Sensor node application**

The application starts when the sensor device is on and powered by batteries. Stack and parameters initialization is done first in the code. Measuring sensor node waits in active mode until coordinator makes first wake up call (pinging). After the response, device moves inside the while loop, which runs forever. Device is in active mode 15 seconds, making measurements and waiting for coordinators data request. Sensor device answers to the request by sending data packet including readings. After active mode sensor node turns off radio for 3mins 45s. The node in the active mode is not dependent on data request of the coordinator and turns off radio normally after a certain period of time. It carries on its four minutes cycle with or without the request. Figure 34 demonstrates in a simplified way, how the sensor application works.

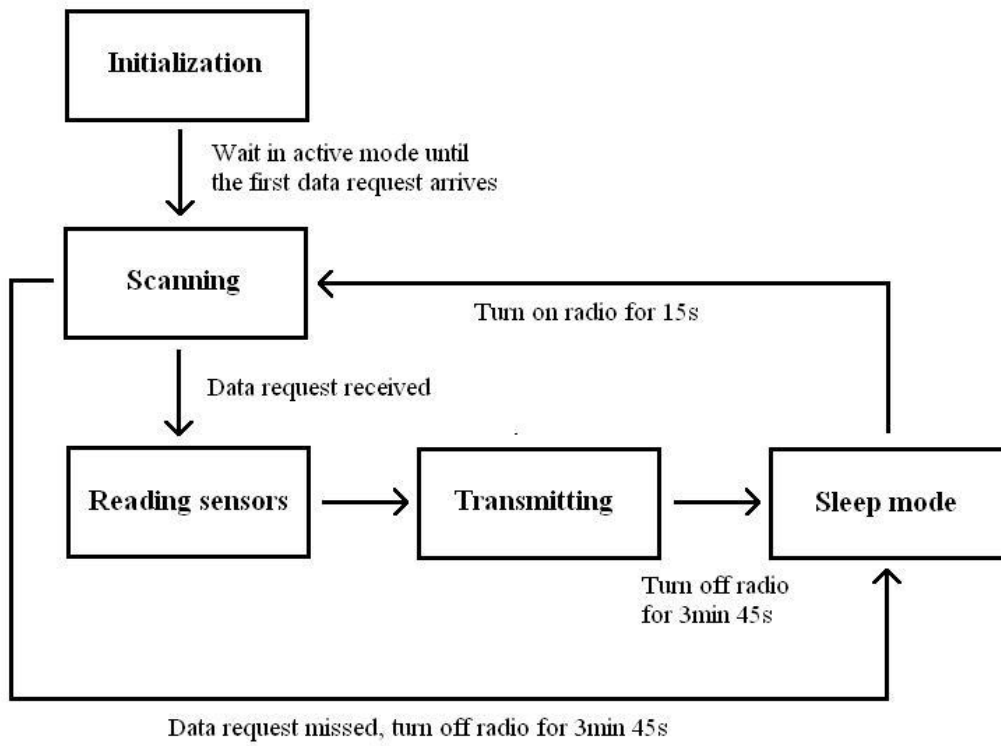

**Figure 34.** A flow diagram of the sensor node application.

### 6.3.2 Sensor data collector application

Data collector application runs on the laptop gathering all upcoming measurement data from the sensor devices. Moreover, its main task is to act as a master device. It polls data from the nodes one by one, showing and saving the readings from the sensors at the specific time moment.

The application user has two options to choose from the menu bar. Either the application starts in a normal way and the software pings devices in certain

order, or the user can decide the restart option with the broadcast address. After the measuring nodes are discovered by using restart selection, the application continues to ping the devices in a defined order. Figure 35 shows a flow diagram of the data collector application.

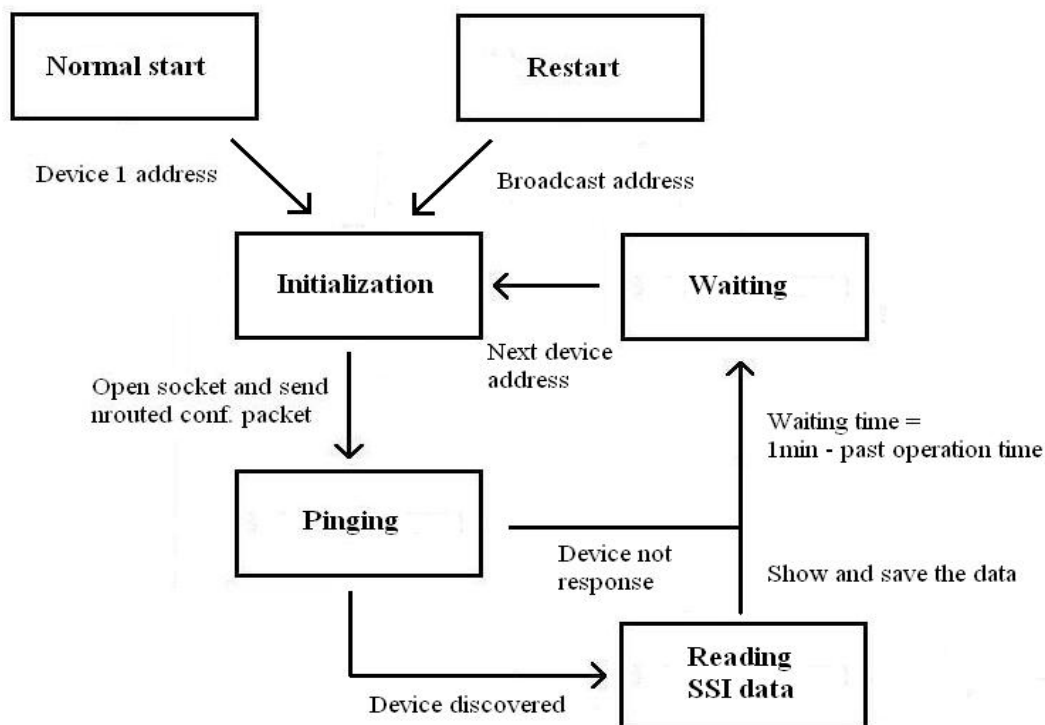

**Figure 35.** Flow diagram of sensor data collector application.

During the initialization, the device address is copied to the end of the nRouted Configuration packet, discovery packet and SSI request packet. After this, the TCP socket opening nRouted configuration is made. Software pings the device ten times, waiting for a response. SSI data reading happens after the sensor node is discovered. If the device is not responding, the software skips the data reading

part and moves on to the next device. The application sleeps the rest of the time, until one minute is past from the last start of the initialization. Application shows on the screen all upcoming events from the nRouted configuration till the data reading. Measurements are stored with time stamps.

## 7 MEASURING ENVIRONMENT

The greenhouse environment is one of the most challenging environments for the wireless sensor network. High humidity and dense flora shrink remarkably the communication range of the wireless devices (See Figure 36). Moisture can also damage sensitive wireless nodes and sensor board. Without a proper covering and protection, the circuit boards do not endure long time and the experiments would be impossible to run. U100 board (See Chapter 6.1.1) with radio part, microcontroller and two AAA size batteries are installed inside the black, plastic box (85 \* 55 \* 30mm). Flat cable is taken through a fitted slid between the box and its cover. The cable connects together U100 and proto sensor board (See Chapter 6.1.2), which locates on top of the plastic box. The surface of the proto board is protected with plastic cover spray. Added to this, Electrostatic Sensitive Device (ESD) plastic sachet envelopes the whole board leaving only the heads of the sensors outside.

Many greenhouses include only one or two measurement spots, which do not provide enough data for accurate control of up to 100 meters long greenhouses. Control setup at Martens greenhouse has only one cabled measurement point in the middle of 18 meters by 80 meters house. Priva's (Priva – Greenhouse Environmental Control Systems) greenhouse measurement box gathers climate values and it is shown in Figure 36.



### **7.1 Martens greenhouse research foundation**

Experiments with wireless sensor nodes were done in Martens greenhouse research foundation. It locates in Yli-Markku, which is a village in Närpiö town in Western Finland. The local area is known for greenhouse growing, and 60% of the Finnish tomatoes are produced there. The foundation plies tomato, cucumber, paprika and flower growing. The total production area in the greenhouses is 12 000 m<sup>2</sup> and Martens has 15 workers. The goal of the foundation is to establish and maintain horticultural institutions in the Ostrobothnia province in which it locates. They try to forge close links to the horticultural colleges and other schools. Martens backs up all kind of experiment and research work, which develops horticultural livelihood in Ostrobothnia. The Figure 36 is taken outside of the foundation (on the left) and inside the greenhouse (on the up and the right).

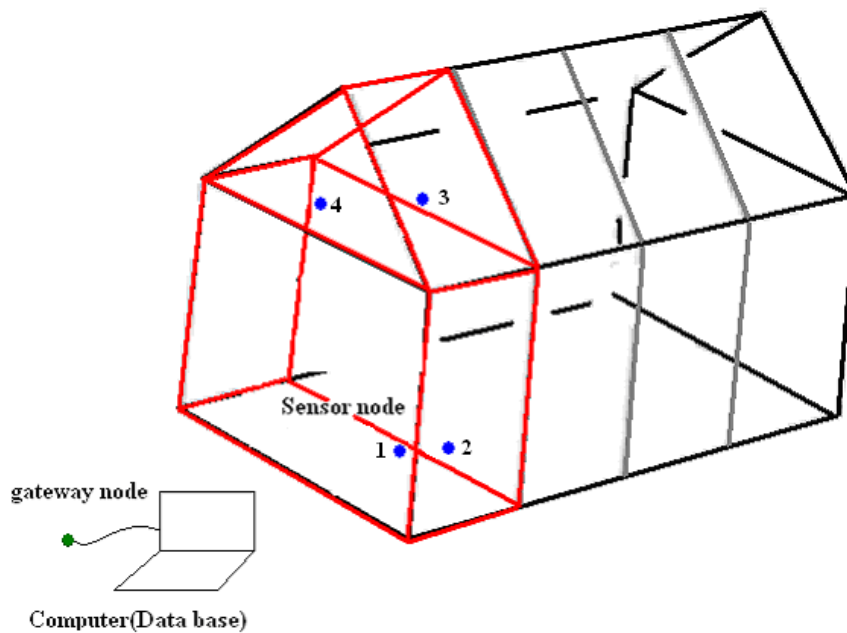

**Figure 36.** Greenhouses at Martens greenhouse research foundation.

## 7.2 Network topology

In the experiments, the network setup is a basic star topology, where four sensor nodes measure the microclimate environment. Gateway node acts as a coordinator and receives the measured data from the sensor nodes. Coordinator is located in the entrance hall of the greenhouse where humidity is 20-30% lower than inside the greenhouse. A laptop computer, which would not tolerate the

greenhouse moisture, is connected to the gateway node by USB-cable. Martens research greenhouse is divided into vertical blocks and the nodes monitor one block at a time. Figure 37 illustrates how the sensor nodes are located all over the greenhouse block. The idea of the vertical distribution is to get better information about, what kind of differences occurs in the climate between lower and upper flora. Greenhouse has many microclimate layers, which we target to monitor and localize.



**Figure 37.** Experimental setup in Martens greenhouse.

Node 1 (See Figure 37) was placed 490 cm away from the glazed side wall of the greenhouse. It was hanged in 120 cm height and the distance to the edge of dense tomato foliage was 410 cm. Node 2 has 180 cm distance to the side wall and it

was placed at the height of 176 cm. The node was placed in a shadowy spot where the nearest lamp was broken. The length between the first plants and the device was 174 cm. Node 3 measured the crown layer in 310 cm height just above the node 1. Node 4 was in the middle of the greenhouse block 930 cm away from the side wall and hanged at a height of 295 cm. The distance from the node to the edge of the foliage was 135 cm. The node 2 and node 3 are shown in Figure 38.



**Figure 38.** The node 2 and node 3 in a greenhouse test setup.

### 7.3 Data collecting

Sensor data collecting application in the laptop communicates through the gateway node requesting data from measuring nodes. The greenhouse with tomato growth and its entrance hall are separated with a thick glazed wall. Metal pipes crisscross the whole wall making the wireless communication between nodes in the both sides more challenging. The coordinator node (in Figure 39)

was placed 640 cm far from the side wall and 240 cm height on a wall of the entrance hall to improve the communication range.



**Figure 39.** The coordinator in the entrance hall.

The application shows all received measurement values and in addition, works as a database where data is saved with the time stamps to the excel file. Table 5 shows example of saved data measured by node 3.

**Table 5.** Example of saved data measured by node 3 with time stamps.**NODE 3**

TIME:	TEMPERATURE(°C):	HUMIDITY(RH%):	IRRADIANCE( $\mu\text{W}/\text{cm}^2$ ):
04/21/08 10:46 AM	29	67	262,7
04/21/08 10:50 AM	28,8	66	262,7
04/21/08 10:54 AM	28,5	66	262,7
04/21/08 10:58 AM	28,8	65	261,69
04/21/08 11:02 AM	29,6	65	262,7
04/21/08 11:06 AM	30,1	65	263,72

## 8 EXPERIMENTS AND RESULTS

In the Martens tomato greenhouse, four sensor nodes measured the microclimate environment for 200 minutes. The main issue of the measurement experiment was to test the functionality and reliability of the wireless sensor network inside the greenhouse with metal structures, dense foliage and high moisture. The maximal communication range, 15 meters was achieved in individual test where the distance was increased between the coordinator and the sensor node inside the dense flora until the connection was lost. A reliable range without losing packets was approximately 10 m. The based on the previous own experiments in the parking lot, the same test in ideal circumstances would raise the communication range of the wireless sensor nodes three times longer.

### 8.1 Power management

Power management was not the principal focus when developing the test network. However, the wireless node equipped with two 1.5V batteries would run for months. The energy consumption of the wireless sensor nodes depends mainly on the active mode time of the node. The radio operation consumes a huge part of the power of the node. In the test setup, the nodes were in the sleep mode 93.75% of the time. Sensor node turned the radio on for 15 seconds waiting for a data request from the coordinator once in every four-minute period. In the sleep mode, the node consumes less than 40  $\mu\text{A}$  current. However, the operating

mode can raise the current till 25 mA, which is an exponential growth compared to the sleep mode.

Both sensors get the energy they need from the batteries through the sensor node. SHT75, temperature/humidity sensor's current supply for time of the measurement readings is 550  $\mu\text{A}$ . The sensor automatically returns to sleep mode after the measurement has ended, dropping the current to 0.31  $\mu\text{A}$ . TAOS TSL262R sensor for the irradiance measuring needs a current of 700  $\mu\text{A}$ . Since the energy saving did not have the first priority in the experiments, sensors were powered all the time.

## 8.2 Network throughput

During the experiment, the coordinator sent 200 data requests, and each sensor node responded 50 times. Ten packets with readings were not received correctly or at all. Throughput between the nodes did not differ substantially, and many reasons can explain why node 1 lost three packets more than node 2. For example, two workers were picking ripe tomatoes and they might have influenced on the throughput by disturbing the communication. The throughput of the network is represented in Table 6. Overall, 95% total throughput was an excellent result in the tedious greenhouse environment.



**Table 6.** Throughput of the sensor nodes.

NODE 1		NODE 2		NODE 3		NODE 4	
PACKET TRANSMITTED	50	PACKET TRANSMITTED	50	PACKET TRANSMITTED	50	PACKET TRANSMITTED	50
RECEIVED	46	RECEIVED	49	RECEIVED	47	RECEIVED	48
PACKET LOSS	8%	PACKET LOSS	2%	PACKET LOSS	6%	PACKET LOSS	4%
<b>TOTAL THROUGHPUT</b>							
PACKET TRANSMITTED	<b>200</b>						
RECEIVED	<b>190</b>						
PACKET LOSS	<b>5%</b>						

### 8.3 Results

Four measuring nodes were deployed all over the greenhouse block to find out possible microclimate layers and their differences. Each node read temperature, humidity and irradiance values once in four minute -intervals over three hours.

A fickle weather on the measurement day affected the results. The sun was shining for a half an hour in the beginning of the test and during shorter periods later on during the day. The greenhouse environmental control system, Priva, adjusted the ventilation, heating and misting systems having 15 minutes delay in the control loop. Priva's measurement box located in the middle of the greenhouse, and the block where sensor nodes were placed, was in the greenhouse's south end.

In Figure 40 temperature values from the four wireless nodes are shown. At the beginning of the test, the sun influenced strongly on the readings. Node 1 was far away from both of the walls and from the roof of the greenhouse, and

temperature stayed stable most of the time. Priva -greenhouse control system's 15 minutes delay explains, why temperature raised over 30 Celsius in some spots before the roof windows were opened. A partly cloudy weather balanced the results between the nodes for the rest of the experiment. The node 3 and the node 4 were both placed on the crown layer of the tomato growth. A slant roof of the greenhouse made the distance from the node to the roof three meters longer with node 4 than node 3. Therefore, node 4 had one degree lower average temperature value. Node 2 was located near the side wall, of which the sun was heating, raising the temperature measured by the node.

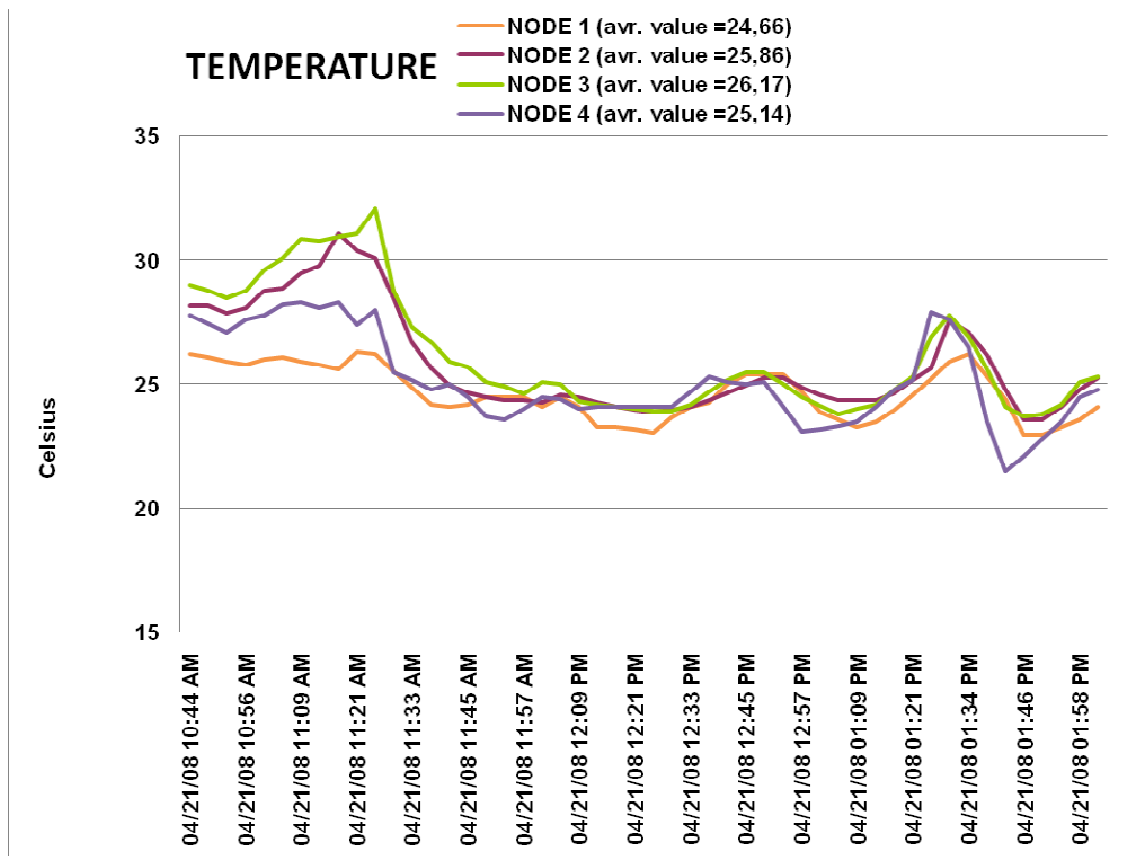

**Figure 40.** Temperature measurement results.

The relation between the humidity and temperature is explained in Chapter 2.1. The results of the measurements support the idea, that lowering of the relative humidity increases the air temperature and vice versa. Figure 41 presents a graph of the changes in relative humidity between four nodes. Comparison between temperature and humidity values shows how variables are linked together. For example, two distinct drops in humidity are clearly to be seen in the Figure 41. Temperature values raised at the same time when moisture dropped. Relative humidity did not differ much between the nodes. Node 1 and 2 were placed on a shadowy spot, and they measured a little bit higher moisture than nodes on the upper layer.

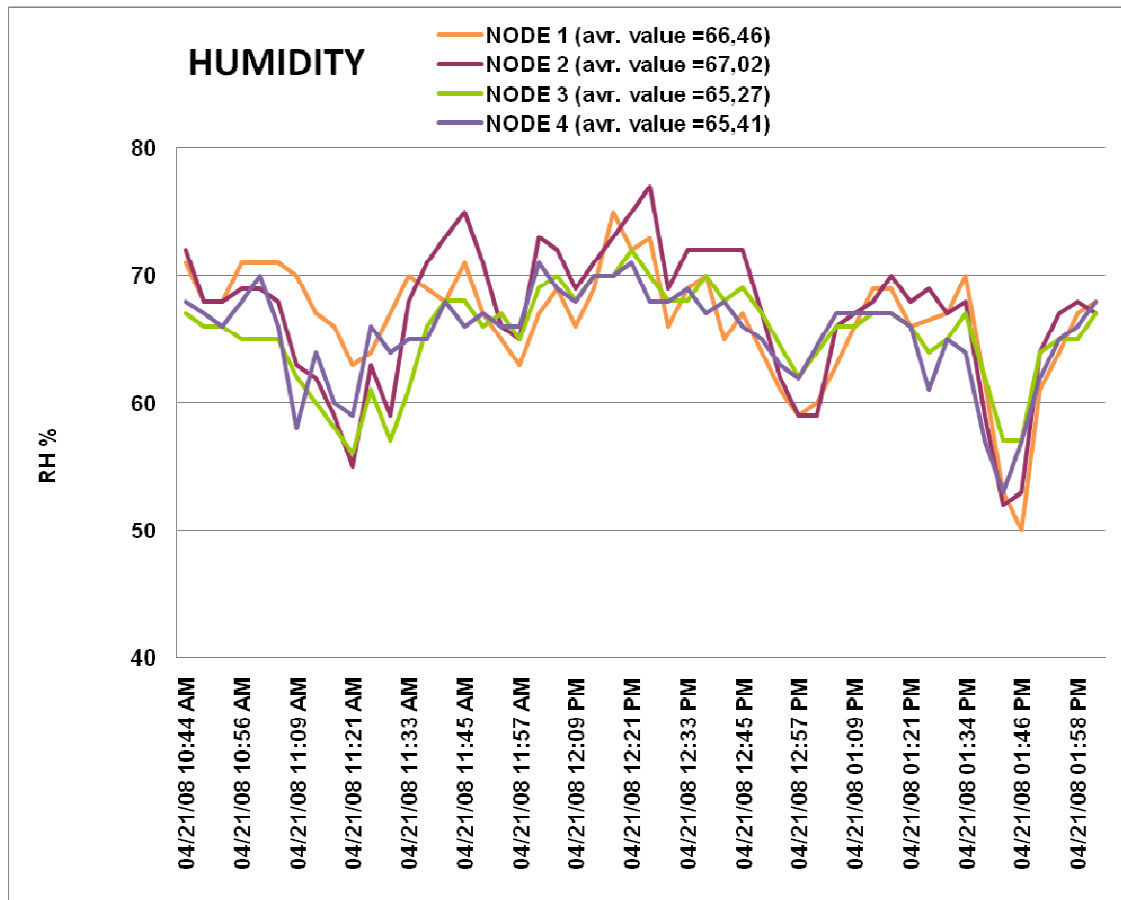

**Figure 41.** Relative humidity measurement results.

The biggest differences between the readings of the nodes occurred in irradiance values, which are illustrated in Figure 42. Node 3 had a straight line-of-sight connection to the sky through the glazed roof and irradiance was almost all the time over  $260\mu\text{W}/\text{cm}^2$ . The only drop in the irradiance happened after the longer sunny period. Same phenomenon occurred with node 4, which was placed 15cm lower than node 4. Also, the slant roof of the greenhouse could drop the average irradiance  $30\mu\text{W}/\text{cm}^2$  comparing to the node 3. The sunny periods during the measurements can be seen from the irradiance values measured by node 1 and

node 2. Both nodes were placed under two meters height, surrounded by dense flora, which led to an increased irradiance value over  $100\mu\text{W}/\text{cm}^2$  only during the sunshine.

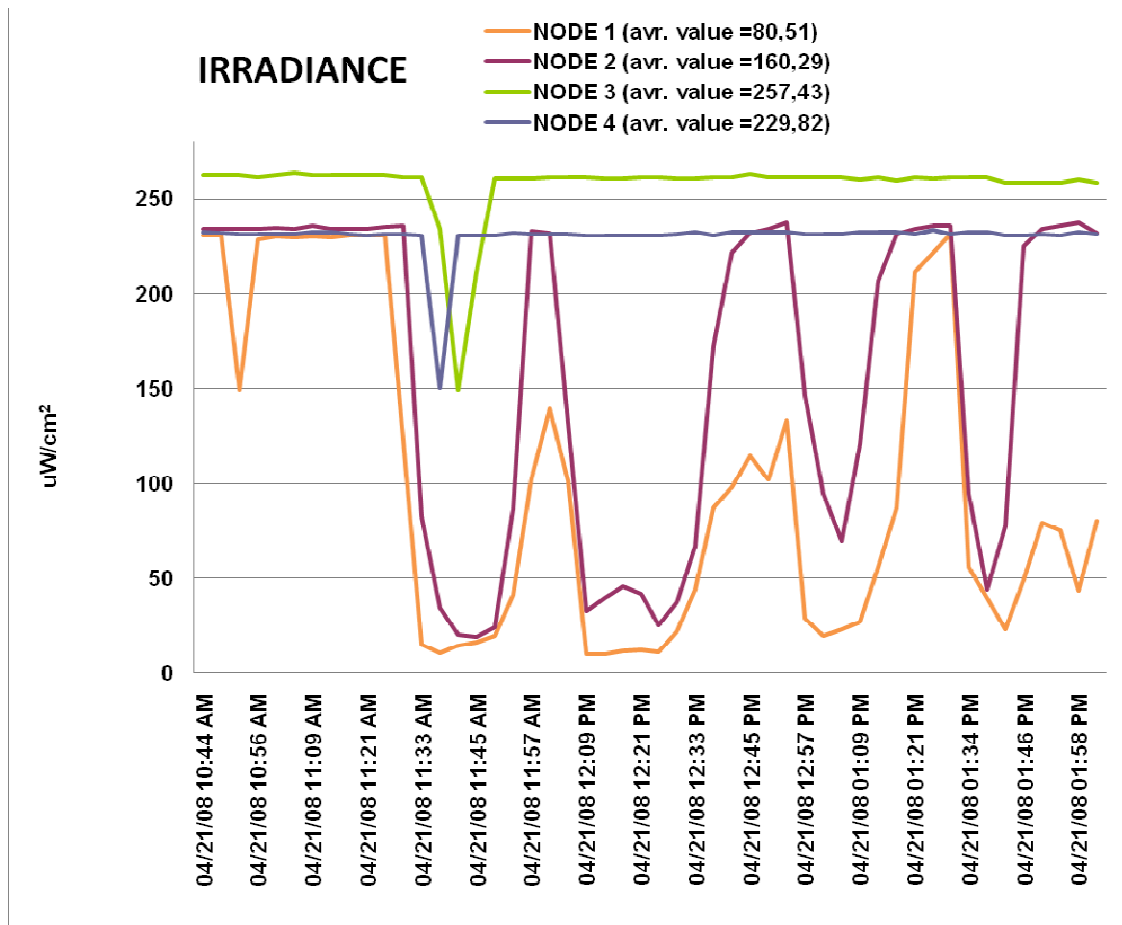

Figure 42. Irradiance measurement results.

## 9 CONCLUSIONS AND THE FUTURE WORK

The efficient automation on greenhouse environment monitoring and control require new and revolutionary solutions. Wireless sensor networks can respond to requirement by offering an accurate and easily configurable monitoring system. The experiments made in the Martens greenhouse prove the operation capability of the WSN in challenging environments. High humidity and dense tomato growth notably shrink the operation range of the wireless sensor nodes. However, simple star topology network succeeded in its mission to gather data from the microclimate of the greenhouse. High moisture forced to consider the possible damages and to protect sensitive boards carefully. When running the experiments, another board damaging factor was noticed. The pollen from the tomato flowers colored one of the black plastic boxes yellow. Small particles of the pollen could also block the measuring component of the sensors, affecting the measuring results.

The long sleep modes and periodical communication in the test setup fulfilled the requirements for the effective wireless sensor network. Each sensor node was receiving and sending packets one at the time. Measuring node was only able to respond to discover and data requests of the coordinator. Still, the energy consumption could easily be cut dozens of percents. The sleep time of the node was 93.75%, which could be increased over 97.50% by shortening the operation time from 15s to five seconds. Sensors were turned on all the time. Both, SHT75 humidity/temperature and irradiance TSL262R sensors are suitable for the low power nodes. Especially, the SHT75 with low current sleep mode and accurate

sensors is made for wireless nodes powered by batteries. Irradiance sensor does not have the sleep mode at all, and to save energy it ought to be turned off most of the time. Figaro's TGS4161 carbon dioxide sensor's several minutes measuring time and 5V supply voltage are the reasons why is it not suitable for the energy efficient wireless node with batteries.

Obviously, there is a need for further study to improve the network architecture. The range of the network should be more extensive, which can be done by using multihop network, amplifiers in transmitters or both together. Sensinode's node has 1mW transmission power. In Finland, the biggest allowed transmission power is 10 mW for 2.4 GHz band, so the amplifier could boost transmission power ten times stronger, though it would also increase the energy consumption. Important carbon dioxide sensor could be implemented to the network by connecting it to the plug-in router node. Also other sensors, like soil moisture sensor, could be considered.

Greenhouse monitoring is one attractive application field to create a wireless automation system. The idea is to expand the use of the wireless sensor nodes to the control and adjustment side, by creating thoroughly-examined wireless monitoring system with all the necessary improvements.

**REFERENCES**

Arkko S., Hämäläinen-Forslund P., Koskinen P., Krannula A., Miettinen T., Miettinen V., Saario M. & Vainio H. (1995) Hyvä hyötytarha. WSOY, Porvoo, Finland. 302 p.

Atmel AVR AT90LS8535 Advance Information Datasheet. [Online]. Available: [http://www.datasheetcatalog.com/datasheets\\_pdf/A/T/9/0/AT90LS8535.shtml](http://www.datasheetcatalog.com/datasheets_pdf/A/T/9/0/AT90LS8535.shtml)

Atmel AVR AT90S2313 Advance Information Datasheet. [Online]. Available: [http://www.atmel.com/dyn/resources/prod\\_documents/doc0839.pdf](http://www.atmel.com/dyn/resources/prod_documents/doc0839.pdf)

Berkeley Wireless Motes. [Online]. Available: <http://www.cbow.com>.

Callaway E. H., Jr. (2003). Wireless Sensor Network: Architectures and Protocols. CRC Press LLC, Florida, USA, 342 p.

Callaway E., Gorday P. & Hester L. (2002). Home networking with IEEE 802.15.4. IEEE Communication Magazine. vol. 40, no 8, August 2002. Pages: 70-77.

Chipcon AS Smart RFCC1000 PRELIMINARY Datasheet (rev. 2.1) 2002-04-19. (Referred 1.3.2008). [Online]. Available: <http://www.datasheetarchive.com/CC1000-datasheet.html>



Chipcon AS SmartRF® CC2420.(2004). Preliminary Datasheet (rev 1.2), 2004-06-09. (Referred 25.2.2008). [Online]. Available: <http://inst.eecs.berkeley.edu/~cs150/Documents/CC2420.pdf>

Culler D.E. & Hui J. (2007). 6LoWPAN tutorial. IP on IEEE 802.15.4. Low-Power Wireless. Arch Rock corporation. (Referred 10.2.2008). [Online]. Available: [www.archrock.com/downloads/resources/6LoWPAN-tutorial.pdf](http://www.archrock.com/downloads/resources/6LoWPAN-tutorial.pdf)

Energy Saving LED Adopted for Chrysanthemum Cultivation. (Referred 21.02.2008). [Online]. Available: <http://www.japanfs.org/db/1676-e>

Figaro engineering inc. (2003). TGS 4161 - for the detection of Carbon Dioxide. [Online]. Available: <http://www.figarosensor.com/products/4161pdf>

Greenhouse guide. (Referred 20.02.2008). [Online]. Available: <http://www.littlegreenhouse.com/guide.shtml>

Hyyryläinen J. & Jantunen I. (2005). SSI protocol specification Version 1.0. [Online]. Available: <http://www.ssiprotocol.net>

IEEE Std 802.15.4. (2003). Standard for Part 15.4: Wireless Medium Access Control (MAC) and Physical Layer (PHY) Specifications for Low-Rate Wireless Personal Area Networks (LR .WPANs.) 1. of September in 2003, New York, USA 679s. (Referred 29.11.2007). [Online]. Available: <http://standards.ieee.org/getieee802/download/802.15.4-2003.pdf>

Kangasniemi J. (2005). Virransäästömenetelmät langattomassa sensoriverkossa. Oulun yliopisto, sähkö- ja tietoliikenteen osasto. Master of Thesis . 68 p.

Khanh T. J. (2005) ZigBee SoCs provide cost-effective solutions. Integrating a radio transceiver, data processing unit, memory and user-application features. on one chip. (Referred 2.2.2008). [Online]. Available: <http://www.eetimes.com/showArticle.jhtml?articleID=173600329>

Kinney P. (2003). ZigBee Technology: Wireless Control that Simly works. Communication Design Conference, 2.10.2003, Pages: 1-20.

Liu H, Meng Z. & Cui S. (2007). A Wireless Sensor Network Prototype for Environmental Monitoring in Greenhouses. Presented at Wireless Communications, Networking and Mobile Computing 2007 (WiCom 2007), International Conference on 21-25 Sept. 2007 Page(s): 2344 – 2347.

Mancuso M. & Bustaffa F. (2006). A Wireless Sensors Network for Monitoring Environmental Variables in a Tomato Greenhouse. Presented at 6<sup>th</sup> IEEE International Workshop on Factory Communication Systems in Torino, Italy, June 28-30, 2006.

Martens Greenhouse Research Foundation. [Online]. Available: <http://www.martens.fi>

Microsystems platform for MOBILE Services and Applications (MIMOSA).

[Online]. Available: <http://www.mimosa-fp6.com>

Montenegro G., Kushalnagar N., "Transmission of IPv6 Packets over IEEE 802.15.4 Networks," Internet-Draft, IETF, September 2007.

Pahlavan K. & Krishnamurthy P. (2002). Principles of Wireless Network. Prentice Hall PTR, Upper Saddle River, USA, 581 p.

Paradiso J.A. & Starner T. (2005). Energy scavenging for mobile and wireless electronics. Pervasive Computing, IEEE Volume 4, Issue 1, Jan.-March 2005 Pages:18 – 27.

Petersen H. (1981). Viljelemme kasvihuoneessa. Weiling+Göös, Espoo, Finland. 143 p.

PRIVA - Greenhouse Environmental Control Systems. [Online]. Available: <http://www.priva.ca/>

RFM TR 1000 RF transceiver data. (Referred 1.3.2008). [Online]. Available: <http://www.rfm.com/products/data/tr1000.pdf>

Salminen M. (1998). Luonnonmukaisen kasvihuonetekniikan kehittäminen. Kenttäkokeet 1996. Maatalouden tutkimuskeskuksen julkaisuja. Sarja B 17. Jokioinen: Maatalouden tutkimuskeskus, Finland. 47 p.

Shelby Z. (2008). OEM IP-based Wireless Embedded and Sensor Networks: The WiFi of the Embedded World. [Online]. Available: [http://www.sensinode.com/pdfs/sensinode-wp1-why\\_ip\\_wsn.pdf](http://www.sensinode.com/pdfs/sensinode-wp1-why_ip_wsn.pdf)

Sensinode (2006). Micro Hardware Manual v1.6. [Online]. Available: [www.sensinode.com/pdfs/sensinode-manual-hw.pdf](http://www.sensinode.com/pdfs/sensinode-manual-hw.pdf)

Sensinode (2006). nRoute Protocol Specification v0.6. [Online]. Available: <http://www.sensinode.com/pdfs/sensinode-manual-nrp.pdf>

Sensinode (2007). OEM Product catalog. [Online]. Available: <http://www.sensinode.com/pdfs/sensinode/catalog20071101.pdf>

Sensinode (2008). NanoStack Manual v1.0.3. [Online]. Available: <http://www.sensinode.com/pdfs/sensinode-manual-nanostack-v1.0.3d.pdf>

Sensirion (2007). SHT1x / SHT7x Humidity & Temperature Sensor v.3.0.1. [Online]. Available: [http://www.sensirion.com/en/pdf/product\\_information/Data\\_Sheet\\_humidity\\_sensor\\_SHT1x\\_SHT7x\\_E.pdf](http://www.sensirion.com/en/pdf/product_information/Data_Sheet_humidity_sensor_SHT1x_SHT7x_E.pdf)

Stanislav S & Kresimir M. (2006). ZigBee wireless standard. 48th International Symposium ELMAR-2006, 07-09 June 2006, Zadar, Croatia.

Texas Advanced Optoelectronic Solutions Inc. (2003). TSL260R, TSL261R, TSL262R Light to voltage optical sensors. [Online]. Available: <http://www.roborugby.org/docs/Taos-TSL260R.pdf>

Texas Instrument. (2006). MSP430x1xx Family User guide. (Referred 20.2.2008). [Online]. Available: <http://www.siphec.com/microcontroller/MSP430x1xx%20Family%20User's%20Guide.pdf>

Timmerman G.J. & Kamp P.G.H. (2003). Computerised Environmental Control in Greenhouses. PTC, The Netherlands. 265 p.

Viestintävirasto. (2005). MÄÄRÄYS, luvasta vapaiden radiolähettimien yhteistaajuuksista ja käytöstä. (Referred 29.1.2008). [Online]. Available: <http://www.ficora.fi/suomi/document/Viestintavirasto15V2005M.pdf>

Vijay R., Kansal A., Hsu J., Friedman J. & Mani S. (2005). Design considerations for solar energy harvesting wireless embedded systems. Information Processing in Sensor Networks, 2005. IPSN 2005. Fourth International Symposium on 15 April 2005 Pages: 457 – 462.

Yum C.-Y., Beam Y., Kang S., Lee Y. & Song J. (2007). Methods to use 6LoWPAN in IPv4 network. Advanced Communication Technology, The 9th International Conference in Phoenix Park, Republic of Korea. Feb. 12-14 2007.

Zheng J. & Lee M.J. (2004). Will IEEE 802.15.4 make ubiquitous networking a reality? IEEE Communications Magazine, vol. 42, no. 6, July 2004, pages: 140-146.

Zigbee Alliance (2004). Zigbee Specification. Versio 1.0 Zigbee Alliance 2.6.2005.  
(Referred 30.1.2008). [Online]. Available:  
[http://www.zigbee.org/en/spec\\_download/download\\_request.asp](http://www.zigbee.org/en/spec_download/download_request.asp)

Åberg Secher M. (1998). Kasvihuone. Otava, Helsinki, Finland. 120 p.