

UNIVERSITY OF VAASA

FACULTY OF TECHNOLOGY

COMPUTER SCIENCE

Kimmo Levonen

MULTIPLEXER TECHNOLOGY IN UTILITY AUTOMATION

Master's thesis for the degree of Master of Science in Technology submitted for inspection in Vaasa, 7th of September, 2009.

Supervisor

Professor Matti Linna

Instructor

M.Sc. (Tech.) Harri Paulasaari

TABLE OF CONTENTS	page
ABBREVIATIONS	5
ABSTRACT	7
TIIVISTELMÄ	8
1. INTRODUCTION	9
1.1. Objectives and scope	9
1.2. Structure of the thesis	10
2. COMMON MULTIPLEXER TECHNOLOGY	12
2.1. Multiplexer in telecommunication	12
2.2. Frequency division multiplexing	12
2.3. Time division multiplexing	14
2.4. Statistical time division multiplexing	15
2.5. Wavelength division multiplexing	16
2.6. Plesiochronous digital hierarchy	17
2.7. Synchronous digital hierarchy	19
2.7.1. Synchronous transmission	20
2.7.2. SDH multiplexing structure	21
2.7.3. Synchronous transport module	22
2.7.4. Protection schemes	25
2.7.5. Ethernet over SDH	28
3. UTILITY AUTOMATION SYSTEMS	29
3.1. Supervisory control and data acquisition	29
3.2. Substation automation	31
3.3. Protection systems	32
3.4. Teleprotection	33

4.	ABB'S MULTIPLEXER PRODUCTS	34
4.1.	FOX515-family	34
4.2.	Universal Configuration Software Tool	37
4.3.	FOXMAN	37
5.	FOX515 CHARACTERISTICS	38
5.1.	Platform	38
5.2.	Bus-structure	39
5.3.	Configuration	39
5.3.1.	Cross-connections	40
5.3.2.	Synchronization	40
5.3.3.	Embedded software	41
5.4.	Network topologies	42
5.5.	Network management	42
5.6.	Alarms	43
5.7.	Traffic protection	43
5.8.	Hardware protection	44
6.	APPLICATIONS WITH FOX515	45
6.1.	SCADA	45
6.2.	Substation automation	46
6.3.	Teleprotection	46
6.4.	Voice communication	47
6.5.	Video applications	48
6.6.	Data services	48
7.	PERFORMANCE ANALYSIS	50
7.1.	Availability	50
7.2.	Response times	52
7.3.	Communications requirements	53
8.	EXPERIMENTS AND CALCULATIONS	55
8.1.	Test system arrangements	55

8.2. Teleprotection operating times	56
8.3. System availability	57
9. CONCLUSIONS	60
REFERENCES	62

ABBREVIATIONS

ANSI	American National Standards Institute
APS	Automatic Protection Switching
ATM	Asynchronous Transfer Mode
AU	Administrative Unit
AUG	Administrative Unit Group
C	Container
CEPT	European Conference of Postal and Telecommunications Administrations
CWDM	Coarse Wavelength Division Multiplexing
DCC	Data Communication Channel
DWDM	Dense Wavelength Division Multiplexing
EMC	Electromagnetic Compatibility
EoS	Ethernet over SDH
ETSI	European Telecommunications Standards Institute
FDM	Frequency Division Multiplexing
GPS	Global Positioning System
HDSL	High bit rate Digital Subscriber Line
IEC	International Electrotechnical Commission
IED	Intelligent Electronic Device
IP	Internet Protocol
ISDN	Integrated Services Digital Network
ISO	International Organization for Standardization
ITU-T	International Telecommunication Union - Telecommunication Standardization Sector
LAN	Local Area Network
LTP	Linear Trail Protection
MSOH	Multiplex Section Overhead
MSP	Multiplex Section Protection
OPC	Object Linking and Embedding for Process Control
OSI	Open Systems Interconnect
PCM	Pulse Code Modulation

PDH	Plesiochronous Digital Hierarchy
PLC	Programmable Logic Controller
POH	Path Overhead
PRC	Primary Reference Clock
PSU	Power Supply Unit
QoS	Quality of service
RSOH	Regenerator Section Overhead
RTU	Remote Terminal Unit
SA	Substation Automation
SAS	ABB Oy, Substation Automation Systems
SCADA	Supervisory Control and Data Acquisition
SDH	Synchronous Digital Hierarchy
SNCP	Subnetwork Connection Protection
SOH	Section Overhead
SONET	Synchronous Optical Network
STDM	Statistical Time Division Multiplexing
STM	Synchronous Transport Module
STS	Synchronous Transport Signal
TCP	Transmission Control Protocol
TDM	Time Division Multiplexing
TU	Tributary Unit
TUG	Tributary Unit Group
UCST	Universal Configuration Software Tool
VC	Virtual Container
VLAN	Virtual Local Area Network
VoIP	Voice over IP
VPN	Virtual Private Network
WAN	Wide Area Network
WDM	Wavelength Division Multiplexing

UNIVERSITY OF VAASA**Faculty of Technology**

Author: Kimmo Levonen
Topic of the Thesis: Multiplexer Technology in Utility Automation
Supervisor: Professor Matti Linna
Instructor: M.Sc. (Tech.) Harri Paulasaari
Degree: Master of Science in Technology
Department: Department of Computer Science
Degree Programme: Degree Programme in Information Technology
Major of Subject: Software Engineering
Year of Entering the University: 2002
Year of Completing the Thesis: 2009 **Pages:** 66

ABSTRACT

In utility automation systems, data communication links have the essential role to convey real-time system between control centers and substations. Therefore, reliable and flexible communications are vital to run modern utility network in a safe and properly controlled way.

In this thesis, possibilities of multiplexer technology in communications for utility automation systems are reviewed. At the beginning of this thesis, theory about multiplexing, especially SDH data transmission technology, and essential utility automation systems are discussed. Thereafter, the thesis concentrates on the characteristics and potential applications of the employer's multiplexer device. Eventually, the performance requirements for the device are analyzed from the utility automation systems' perspective and also some performance figures are measured with a build-up test system.

Multiplexer technology was found to be well suitable for the underlying communications in utility automation systems. Especially the efficient protection schemes and network manageability makes SDH systems highly available and ensures quick reconfiguration in fault situations. Teleprotection that makes very fast operating times for power line protection possible, came up as the most important application.

KEYWORDS: Multiplexer technology, utility automation, SDH, FOX515.

VAASAN YLIOPISTO**Teknillinen tiedekunta**

Tekijä:	Kimmo Levonen
Diplomityön nimi:	Kanavointitekniikka energiayhtiöiden automaatiassa
Valvojan nimi:	Professori Matti Linna
Ohjaajan nimi:	DI Harri Paulasaari
Tutkinto:	Diplomi-insinööri
Laitos:	Tietotekniikan laitos
Koulutusohjelma:	Tietotekniikan koulutusohjelma
Suunta:	Ohjelmistotekniikka
Opintojen aloitusvuosi:	2002
Diplomityön valmistumisvuosi:	2009

Sivumäärä: 66

TIIVISTELMÄ

Energiayhtiöiden automaatiojärjestelmissä tietoliikenneyhteyksien keskeinen rooli on välittää reaaliaikaista järjestelmätietoa keskusvalvomoiden ja ala-asemien välillä. Siksi luotettavat ja joustavat viestiyhteydet ovat elintärkeitä nykyaikaisen energiatoimitusverkon hoitamiseen turvallisesti asianmukaisesti valvottuna.

Tässä työssä on tarkasteltu kanavointitekniikan tarjoamia mahdollisuuksia energiayhtiöiden automaatiojärjestelmien viestintäyhteyksissä. Työssä on aluksi käyty läpi teoriaa kanavointitekniikasta, erityisesti SDH-tiedonsiirtotekniikan osalta, sekä keskeisistä energiayhtiöiden automaatiojärjestelmistä. Tämän jälkeen työssä on keskitytty tilaajan kanavointilaitteen ominaisuuksiin ja sovellusmahdollisuuksiin. Työn lopussa laitteen suorituskykyä on analysoitu automaatiojärjestelmien vaatimusten kannalta, sekä testattu suoritusarvoja käytännössä testaustarkoitukseen rakennetulla järjestelmällä.

Työssä todettiin kanavointitekniikan soveltuvan ominaisuuksiltaan hyvin käytettäväksi tiedonsiirtotekniikaksi energiayhtiöiden automaatiojärjestelmille. Etenkin SDH:n tehokkaat varmennusmenetelmät ja verkon hyvä hallittavuus mahdollistavat järjestelmien korkean käytettävyyden sekä nopean reagoinnin vikatilanteissa. Sovelluskohteista tärkeimmäksi nousi viestiyhteyksiä käyttävä suojausjärjestelmä, joka mahdollistaa erittäin nopeat toiminta-ajat sähköverkon johdonsuojauksessa.

AVAINSANAT: Kanavointitekniikka, energiayhtiöiden automaatio, SDH, FOX515.

1. INTRODUCTION

Telecommunication is an indispensable tool in today's utility automation. Communication links have the essential role to convey real-time system data between control centers and sites, between control centers and between sites as well. Therefore reliable and flexible communication services are vital to run modern electrical grid or pipeline in a safe and properly controlled way.

Recent advances in telecommunications services, software applications and network technologies are working together. Many of these are converging towards networks that support multiple services, which make it possible to implement a single utility wide area network (WAN) that can meet most of a utility company's network needs for both operational and administrative traffic. Broadband products like digital multiplexers have arisen to the portfolio of utility companies' telecommunications solutions.

ABB Oy, Substation Automation Systems (SAS) is a department that supplies operation control and support systems for industry and utility companies. Typical products include supervisory control and data acquisition (SCADA) systems that are used to monitor and control utility companies' processes.

ABB has years of experience in multiplexer technology. Recently, multiplexer products have also been adopted by SAS as a choice for communications backbone of utilities automation systems, which has inspired the need for closer study about multiplexer technology and its potentiality in utility automation.

1.1. Objectives and scope

The purpose of this thesis is to review multiplexer technology, and to determine its possibilities and capabilities from the perspective of utility industry. Accordingly, the goal is to examine the suitability of multiplexer technology in utility communications solutions, especially with the essential automation signals and systems. The main concern is in general on synchronous digital hierarchy (SDH) technology and in

particular FOX515: The utility specific SDH multiplexer product that ABB provides to its customers. Other products from the ABB's FOX-family are briefly reviewed, though the main focus is on the FOX515 and its characteristics and possibilities.

The theoretical part of this thesis is based on examining and reviewing literature, including journals, standards and application specific publications, as well as ABB data sheets and course material. Knowledge is also gathered by interviewing industrial specialists. For the empirical part, testing environment is implemented for practical examples and experiments.

Utility automation covers an operating area from power and district heating networks to gas, oil and water pipeline networks. This thesis, however, concentrates on electrical power systems, as it is the core business area of ABB. Anyway, the basic functions and requirements for automation are similar in each case and therefore this study is applicable in other utility industries as well.

1.2. Structure of the thesis

Chapter 2 begins this thesis with a brief evolution of the multiplexer technology, and gives basic background information about common multiplexing techniques. This chapter also examines the digital multiplexing hierarchies, concentrating on SDH and its structure and main features. Chapter 3 presents the essential automation systems that are used by utility companies, especially in power industry.

The following chapters focus in particular to the FOX515 multiplexer. Chapter 4 gives an overview of the ABB's multiplexer products and introduces the FOX515, while Chapter 5 concentrates on the base technology and the main features of FOX515. In Chapter 6, the potential of multiplexer technology in utility automation systems are considered and related applications are reviewed.

In Chapter 7, the performance issues and requirements that are set by standards and the mission-critical applications are discussed. Chapter 8 describes the test system

arrangements and goals and illustrates results for the experiments and the calculations executed with the system. In Chapter 9 the final conclusions are drawn.

2. COMMON MULTIPLEXER TECHNOLOGY

Multiplexer is an extremely important device to modern-day telecommunications. Since the year 1874 when Thomas Edison successfully made the first multiplexed transmissions over a telegraph line, multiplexer technology has provided a way to use single communication link as a transmission medium for multiple information sources first in telegraph and telephony communications and later on in video and digital communications. By replacing the need for a high-priced separate link for every point-to-point communication, multiplexer technology has brought significant financial benefit not only for network companies who constructs and owns the links but also for companies that use those links. (Goleniewski 2001: 39–40.)

2.1. Multiplexer in telecommunication

Basic multiplexer is a device that has several input signals and one output signal. Input signals are combined inside a multiplexer and sent as one signal through a communication link. At the receiving end of the link there is a complementary demultiplexer separating the combined signal back to the original signals.

Multiplexers are generally very flexible about the transmission medium and techniques that could be used in the multiplexing process. They support wire communication like electrical copper pairs, coaxial cables and optical fibers as well wireless communication like radio- and microwaves in both circuit and packet switching networks. Moreover, multiplexed and transmitted signals could be either analogical or digital. (Horak 2000: 21.)

2.2. Frequency division multiplexing

Frequency division multiplexing (FDM) is a multiplexing technique for transmitting analog information over cable or wireless transmission link. In FDM the entire

frequency bandwidth of the communications link is separated into smaller bands, one for each incoming signal. Accordingly the signals travel in parallel over the same link, but each signal has a different portion of the frequency spectrum. In Figure 1 it is seen a simple FDM example with three standard 300 to 3400 Hz voice signals. Each signal is modulated with a different channel carrier frequency. In order to successfully take place the corresponding demodulation in the receiving end of the link, the carrier frequencies must be spaced looser than the bandwidths of the input signals. Usually when considering telephone signals, as in this case, there is reserved 4 kHz spectrum from the same wire pair for every voice channel. Therefore the free frequency bands, called guard bands, which separate the carrier channels from each other, are acting as buffer zones to reduce interference between adjacent channels. (Ericsson Telecom AB & Telia AB 1998: 171; Sklar 2004: 660.)

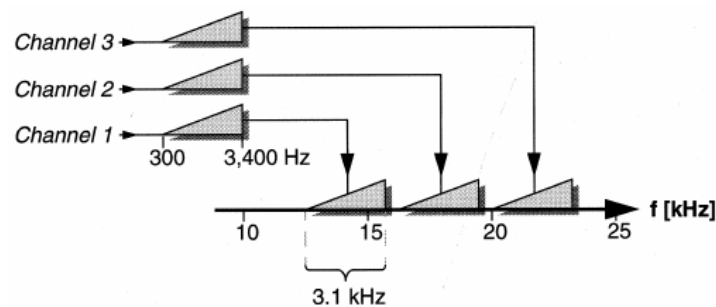

Figure 1. Frequency division multiplexing with three channels (Ericsson Telecom AB & Telia AB 1998: 171).

FDM was the first multiplexing technique and it was used first in telegraphy in the late 1800s. Its rapid development in the early 1900s changed the methods of telephone transmission with the invention of frequency division multiplex telephony, which made it possible to use same wire for transmission of up to 24 telephone signals (Sklar 2004: 660–661).

Since those times the telephone systems have been evolved and nowadays FDM voice circuits are extensively replaced by modern digital telephone systems that can carry much more subchannels over the same wires. Nevertheless, FDM is still common technique in cable TV and in radio networks. (Goleniewski 2001: 42.)

2.3. Time division multiplexing

Time division multiplexing (TDM) is the basic multiplexing technique when considering transmission of digital information. In TDM, the common transmission link is divided into time slots that represent bits or octets, groups of eight bits. Each time slot is sequentially allocated for transmission from a certain input channel, as presented in Figure 2 with three channels. (Ericsson Telecom AB & Telia AB 1998: 171–172.) The allocated time slots must be framed in order to separate out the individual channels in the receiving end of the link. Typical frame consists of one time slot from each channel and one framing bit for synchronization. (Horak 2000: 22.)

It is seen from the Figure 2 that each time slot has only a third of the original slot time, T . Certainly this also means that the capacity of the common link is three times that of each original channel. The principle of TDM allows continuing multiplexing into a higher order, which means that several TDM links can be combined and transmitted through another link with wider bandwidth. E.g., six times higher bit rate can be achieved by multiplexing two TDM links with three voice channels in each. (Ericsson Telecom AB & Telia AB 1998: 172.)

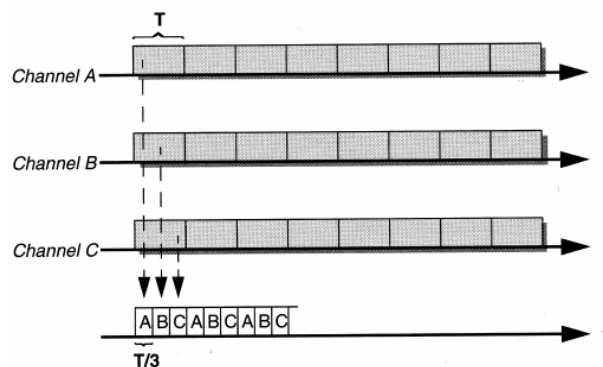

Figure 2. Time division multiplexing with three channels (Ericsson Telecom AB & Telia AB 1998: 172).

TDM-based transmission system was introduced in the early 1960s to meet the growing need for voice telephony. It provided a way to use the same transmission wires more cost-effective by representing signals in binary form by using pulse code modulation

(PCM). In PCM, samples from the analog voice signal is first drawn at the rate of 8000 samples per second and rounded to the nearest integer value. Each value is then presented with 8 bits, giving a 64 kbit/s digital signal. Finally digital values are encoded into a binary pattern that represents the original analogue signal faithfully, which makes the reconstruction of the analog signal possible in the far end of the transmission link. (Uotila 2001: 60.)

In Europe, the adopted standard PCM system consists of thirty voice channels and two additional channels for synchronization and signaling information, where each channel operates at a fixed bit rate of 64 kbit/s. This yields the overall bandwidth to $32 \cdot 64 \text{ kbit/s} = 2048 \text{ kbit/s}$, which is the first level of the digital transmission hierarchy established by International Telecommunication Union - Telecommunication Standardization Sector (ITU-T). (Uotila 2001: 60.)

Nowadays TDM is used in live video streaming, telephone traffic and on the whole in applications, where real-time communication with reserved channel capacity is crucial for continuous live transmission. Of course, this is not the most efficient way to use the transmission capacity because the allocated time slots are statically reserved and cannot be reallocated for use of another channel if the original channel is idle. (Uotila 2001: 59.) However, this type of TDM is more efficient than standard FDM because it provides to transmit more subchannels in the same transmission link. In addition, TDM can be combined with other multiplexing techniques e.g. to carry multiple voice conversations on each channel. (Goleniewski 2001: 43.)

2.4. Statistical time division multiplexing

Statistical time division multiplexing (STDM) is a smarter extension from standard TDM. In STDM, each time slot is allocated dynamically among the active channels, which allows efficient use of the bandwidth. According to Goleniewski (2001: 44), STDM is up to five times more efficient than traditional TDM.

Actually, dynamical allocation allows you to use more channels than there are time slots. If a statistical multiplexer is busy and there are no time slots available, the excess data is stored into a buffer. Of course this may lead to delays and data loss if there is too much traffic in the statistical multiplexer and it runs out of memory. However, statistical multiplexers are intelligent, which means that they have features to detect and correct errors and ability to cease transmission from lower priority channels, but still the risk of delays and data loss remains. (Goleniewski 2001: 43–44.)

Certainly, this type of multiplexing, where efficient use of bandwidth is more essential than constant and reliable connection, is the basis, on which packet-switching technologies like IP and asynchronous transfer mode (ATM) are built (Goleniewski 2001: 44).

2.5. Wavelength division multiplexing

Wavelength division multiplexing (WDM) is actually an optical variant of FDM. It is used to specify multiplexing with high-speed optical fibers. As FDM combines electrical frequencies into one transmission link, WDM acts likewise with frequencies of visible light. The principle of WDM is seen from Figure 3, where three separate wavelengths, λ_1 , λ_2 and λ_3 , are transmitted through same fiber. (Ericsson Telecom AB & Telia AB 1998: 185.)

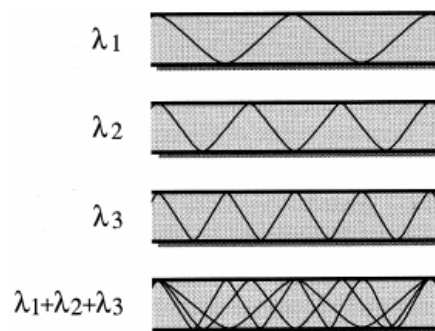

Figure 3. Wavelength division multiplexing with three wavelengths (Ericsson Telecom AB & Telia AB 1998: 186).

Currently WDM development is divided into two different trends depending on the spacing density of separate wavelengths. In coarse wavelength division multiplexing (CWDM), separation between the wavelengths is large (5–50 nm), as dense wavelength division multiplexing (DWDM) is used with less separation (0,1–5 nm). With the higher density, DWDM naturally supports much more wavelengths than CDWM. (Ericsson Telecom AB & Telia AB 1998: 186.)

Along the development of WDM, it has been possible to take more advantage of existing optical fibers and their high capacity. As in the past, it was possible to transmit only one wavelength at a rate of 2,5 Gbit/s in a single fiber, now DWDM operates at 10 Gbit/s with more than hundred separate wavelengths in the same fiber. With carriers over hundred fibers in the same bunch, the potential in WDM is incredible. (Goleniewski 2001: 47–48.)

2.6. Plesiochronous digital hierarchy

As the demands for voice telephony ever increased, it became clear that the first standard TDM signal level, referred as E-1, was not enough to cover the traffic in the trunk network without having to use large numbers of those links separately. So it was decided to continue multiplexing into a higher order. This system was called E-carrier system in Europe and it eventually led to a full hierarchy of standardized bit rates (Goleniewski 2001: 124).

European Conference of Postal and Telecommunications Administrations (CEPT) originally establish E-carrier system and it has also been adopted by ITU-T. E-carrier system is widely used around the world, except USA, Canada and Japan, which has their own variations, T-carrier in North America and J-carrier in Japan. These three carrier systems form the basis of plesiochronous digital hierarchies (PDH). Although the principle is the same in each hierarchy, slight difference between the bit rates makes interworking between separate hierarchies expensive. (ABB 2008b: 14; Goleniewski 2001: 124.)

Table 1 presents the PDH transmission rates followed in Europe. Standard for the second signal level, E-2, involved four 2 Mbit/s (more exactly, 2048 kbit/s) channels in order to produce a single 8 Mbit/s (8448 kbit/s) channel. As the demand for telephony ever arose, higher orders were introduced. Further levels involved also four lower signal level channels, as it was with E-2. So, E-3 was standardized to 34 Mbit/s (34368 kbit/s) and E-4 to 140 Mbit/s (139264 kbit/s). E-5 is also introduced at 565 Mbit/s (564992 kbit/s) bit rate, but it is not recognized by ITU-T. (ABB 2008b: 13–14.)

Table 1. PDH signal hierarchy in Europe.

PDH signal level	Bit rate [kbit/s]	Number of E-0 channels
E-0	64	1
E-1	2 048	30
E-2	8 488	120
E-3	34 368	480
E-4	139 246	1920

PDH is a circuit-switched network model, which was the first system to provide an infrastructure to digitalized voice transmission. Besides PDH specifies the transmission levels it also defines the range of digital traffic types that could be carried in a network. Though PDH was originally designed for voice transmission in a digital manner, this definition made it possible to transmit voice and data over the same link for the first time. (Goleniewski 2001: 124.) Hence, PDH has been used for communications in early automation systems.

However, the principle of PDH is not as simple as it may look like. E.g., combining four 2048 kbit/s E-1 signals should yield an 8192 kbit/s signal, not 8448 kbit/s. Similar differences can also be seen with the higher signal levels. This is due to the fact that each lower level channel have slightly different bit rate, and before the multiplexing can be done in the higher level, channels must be brought up to the same bit rate level by

adding justification bits. The name plesiochronous, which can be translated as almost synchronous, describes this situation well. (ABB 2008b: 14–15.)

The problem with plesiochronous network is that because justification bits are added at each PDH level, lower level channels are lost inside higher speed bit stream. E.g., identifying the exact location of certain 2 Mbit/s line straight from 140 Mbit/s structure is impossible. In order to access that 2 Mbit/s line, whole 140 Mbit/s structure must be demultiplexed down to its 64 constituent 2 Mbit/s lines step by step via 34 Mbit/s and 8 Mbit/s stages. After the 2 Mbit/s line has been identified and extracted, multiplexing must be done via the same stages again up to 140 Mbit/s. Obviously, this makes PDH fairly inflexible and slow with provisioning of services, whilst the equipment required for adding and dropping channels from the PDH stream are extremely expensive. (ABB 2008b: 16.)

Another problem with PDH is in its frame structure, which has insufficient provision for carrying network management information. However, these limitations are not critical in voice-oriented network, but when considering more sophisticated services, PDH can no longer cope. (ABB 2008b: 16.)

2.7. Synchronous digital hierarchy

As digital networks increased in complexity, synchronous high-speed data transmission systems over optical fibers, using originally a single wavelength, were introduced to overcome the limitations of PDH. Two TDM based circuit-switched systems, synchronous digital hierarchy (SDH) by ITU-T and synchronous optical network (SONET) by American National Standards Institute (ANSI), were developed in agreement, though SONET is generally considered as a subset of the worldwide SDH standard. Anyway, these two standards were designed to achieve compatibility between fiber-optic products that are used worldwide, as well as to provide compatibility with the existing PDH equipment. (Ferguson 1994; Goleniewski 2001: 132.)

The main features of SDH technology are the introduction of manageability and protection schemes. Another advantage is transparency of the SDH transmission structure, which makes the individual channels visible in higher level bit stream. Transparency also allows the add/drop operations to be carried out in a single multiplexer, which reduces the equipment chain and shortens the lead times. The efficient frame structure reduces overhead, which increases the utilization rate of the physical network. (ABB 2008b: 17; Ericsson Telecom AB & Telia AB 1998: 213.) These important improvements overcome the main weaknesses of PDH, and moreover, can reduce costs of operation and maintenance significantly.

2.7.1. Synchronous transmission

As being commonly viewed as layer 1 transport protocol in the seven layers open systems interconnect (OSI) model defined by the International Organization of Standardization (ISO), SDH provides physical framework for broadband applications in layers 2 to 4 like ATM and IP. However, SDH can also act as those layers and transport higher-level applications directly. Hence, SDH transmission can be considered as a pipe, which carries lower rate application traffic, such as ATM, IP or PDH, in the form of packages. Moreover, SDH standard provides physical infrastructure for the optical parameters, types of cables and light sources. Its essential role is to manage that the infrastructure is being utilised efficiently, detect failures and recover from them. (ABB 2008b: 18, 21.)

SDH defines a full set of new transmission rates, which are presented in Table 2 together with the corresponding SONET rates. The basic unit of SDH is the synchronous transfer module level one (STM-1) frame, which provides transmission rate of 155 Mbit/s (more exactly, 155,52 Mbit/s). The other most important and currently used SDH levels can be achieved by interleaving four lower level STM frames, like it was earlier with PDH. So the following rates are 622 Mbit/s (622,08 Mbit/s) for STM-4, 2,5 Gbit/s (2488,32 Mbit/s) for STM-16 and 10 Gbit/s (9953,28 Mbit/s) for STM-64. As it can be seen from Table 2, the multiplication operations are exact, because there is no need for justification bits at the SDH level.

Table 2. SDH/SONET transmission rates.

SDH signal level	SONET signal level	Bit rate [Mbit/s]	Payload rate [Mbit/s]
STM-1	STS-3	155,52	150,336
STM-4	STS -12	622,08	601,344
STM-16	STS -48	2 488,32	2 405,376
STM-64	STS -192	9 953,28	9 621,504
STM-256	STS -768	39 813,12	38 486,016

2.7.2. SDH multiplexing structure

SDH multiplexing structure is based on standard-sized virtual containers (VC). They can be viewed as the traffic packages in the SDH pipe, though they are placed inside a synchronous transport module (STM) frame for the actual transport. Virtual container is comprised of two elements: a container (C), which contains packaged information of a lower rate data signal, known as a tributary signal, and the path overhead (POH), which contains control information for identification and management purposes. (ABB 2008b: 24.)

In SDH, there are three basic virtual containers: VC-12, VC-3 and VC-4, each corresponding to a certain tributary signal level. Actually, these levels are equivalent to the most common PDH transmission levels. The signal rates are 2 Mbit/s for VC-12, 34 Mbit/s for VC-3 and 140 Mbit/s for VC-4. (ABB 2008b: 24.)

Virtual containers can be packaged into a higher-order virtual container. E.g. one VC-4 can contain three VC-3s, 63 VC-12s, or combinations of the above within the overall capacity of VC-4. Typical SDH multiplexing route in Europe defined by European Telecommunications Standards Institute (ETSI) is presented in Figure 4.

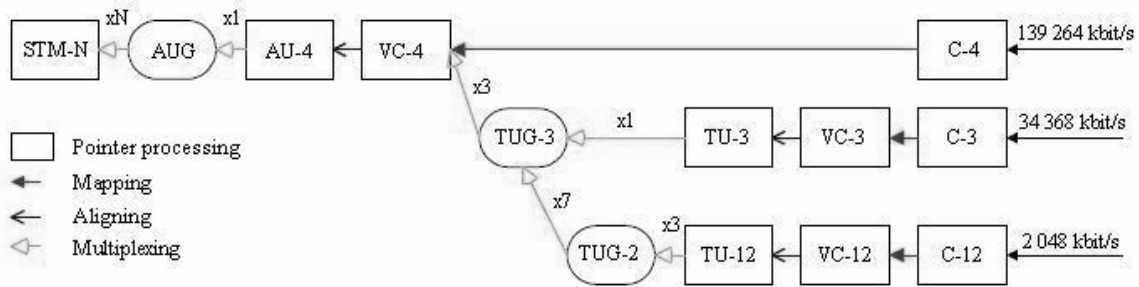

Figure 4. Typical SDH multiplexing route (ABB 2008a).

As seen from the Figure 4, before the combining takes place, each lower order virtual container is first aligned inside a tributary unit (TU) with a pointer indicating its starting position and packed into tributary unit groups (TUGs). TUGs are then multiplexed into a higher order VC-4, which is respectively aligned inside administrative unit (AU-4) and packed into administrative unit group (AUG). This operation, referred as nesting, is used to simplify the transport and management of the signals across the network. (ABB 2008b: 25, 32.) By following this multiplexing path in reverse order, 2 Mbit/s tributary signals are accessible in any level of the data stream.

2.7.3. Synchronous transport module

Basic STM-N frame structure is presented in Figure 5. The general STM-1 frame comprises 2430 (270 * 9) bytes of information. Three main areas of the STM-frame are payload, AU pointer and section overhead (SOH). The payload is formed by one VC-4, which contains either one 140 Mbit/s PDH signal or combination of lower-level signals as a result of nesting. The starting point of the VC-4 is stored into the AU pointer for to indicate the virtual containers exact position within the STM payload. (ABB 2008b: 30,136.)

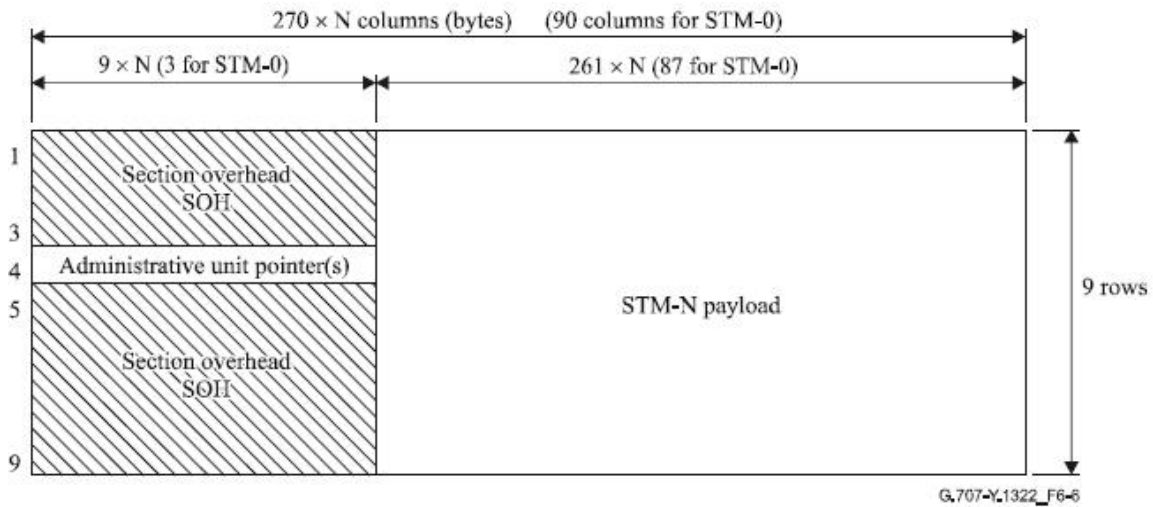

Figure 5. STM-N frame structure (ITU-T Recommendation G.707/Y.1322: 11).

The section overhead, which is divided into regenerator section overhead (RSOH) and multiplex section overhead (MSOH), provides dedicated management channels. It is used for communication between adjacent network elements, more precisely, for synchronization, transmission quality measurement, remote access, service and section failure detection and recovery referred as automatic protection switching (APS). (ABB 2008b: 30, 141–144; Ericsson Telecom AB & Telia AB 1998: 218.)

Content of STM-1 section overhead defined by ITU-T is shown in Figure 6. Description for individual bytes is listed below:

- A1, A2 Framing bytes.
- J0 Regenerator section trace.
- D1-D12 D1, D2 and D3 form a 192 kbit/s data communication channel (DCC) for the regenerator section, while in MSOH bytes from D4 to D12 are reserved for the DCC of the multiplex section with bandwidth of 576 kbit/s. Both DCCs are used for network management.
- E1, E2 Order wire voice channels.

- F1 User channel.
- B1, B2 Parity checks for error detection.
- K1, K2 APS signaling channels.
- S1 Bits 5–8 of S1 byte are allocated for synchronization status messages.
- M1 Multiplex section remote error indication.

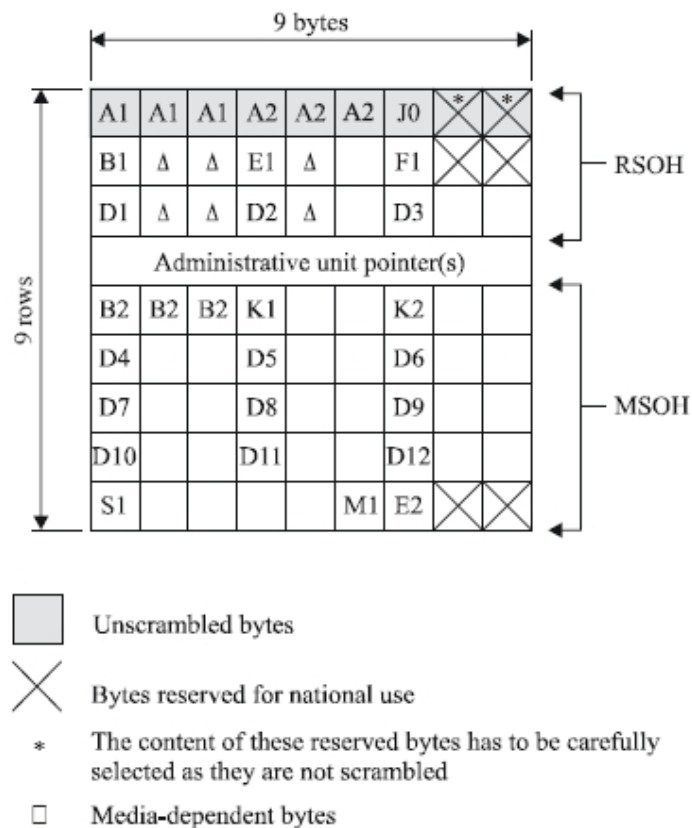

Figure 6. STM-1 section overhead (ITU-T Recommendation G.707/Y.1322: 66).

Since the tributary signals are all synchronous, higher STM transmission rates can be achieved simply by byte interleaving. However, e.g. STM-16 signal can be multiplexed either directly from sixteen STM-1 signals or by using the STM-4 step between. In order to maintain the signal structure, STM-N signals must be N byte interleaved. So

STM-1 signals are interleaved by taking one byte at time from each tributary, as in STM-4 each four-byte group is taken and interleaved with that from the next tributary, thereby the signal structure remains the same in either way. (ABB 2008b: 156.)

2.7.4. Protection schemes

SDH technology offers standardized APS schemes, which ensure that network failures are detected and compensated for before a loss of service occurs. These schemes can be divided into those that protect all the traffic between a section and those that protect individual virtual containers on an end-to-end path.

Linear trail protection (LTP) is a path protection scheme where VC-traffic is transmitted simultaneously in two directions. At the receiving end the path with higher quality is chosen to be the working path, while the other one is dedicated to the protection. In event of a failure in the working path, the receiving end will switch directly to use the protecting path. (ABB 2008b: 74–75.)

Another path protection scheme is subnetwork connection protection (SNCP). In SNCP, the network is divided into several interconnected subnetworks, wherein each subnetwork has its own internal dedicated path protection. Therefore the switching between the working and protecting path can be done at the end node, or at each intermediate node between two subnetworks. This provides more possible protection routes, and hence higher survivability from simultaneous failures can be achieved. (ABB 2008b: 76.)

Principle of SNCP is presented in Figure 7. In normal state, data is transmitted from each intermediate node via two different routes. When the main route is damaged, receiving is switched to the protecting route.

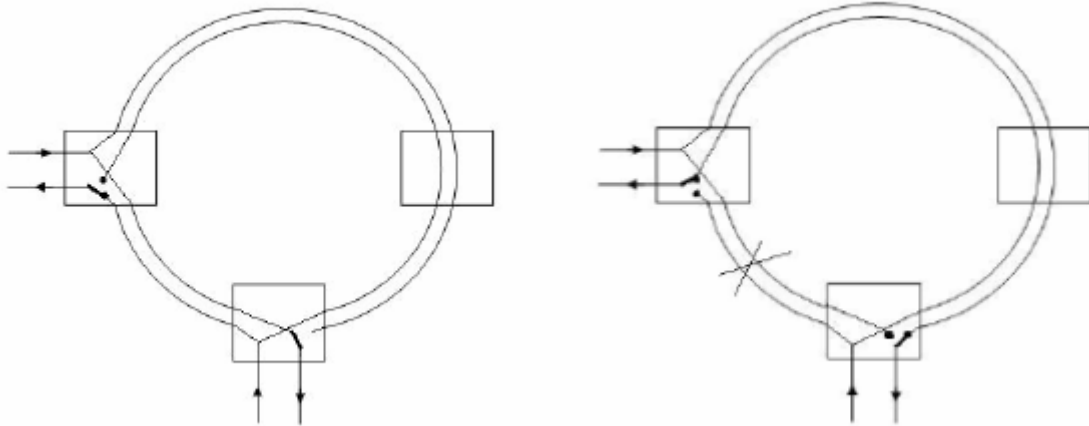

Figure 7. Principle of SNCP (Renfors 2007: 26).

SNCP can be used in mixed topologies, but it is especially efficient with rings, because the topology provides subnetwork with two diverse routes naturally. However, protection paths may become complex and require lots of dedicated capacity, which can cause problems to the control and maintenance operations. Still, SNCP can be used to selective protection of individual channels.

In contrast to the path protection, section protection covers overall protection to the network traffic at the highest level that is STM-traffic. Multiplex section protection (MSP) is considered as protection between two adjacent nodes. It can be achieved in few slightly different ways.

1+1 MSP, presented in Figure 8, means that traffic between two network elements is transmitted via duplicated links. Normally, the working link is used as the main traffic route, but in the event of a failure on the working link, the receiving network element selects the protection link to be used as the main route. Although the protection link reserves large amount of fiber capacity, there is no need for intercommunication between the nodes, which assures fast switch over times. (ABB 2008b: 80.)

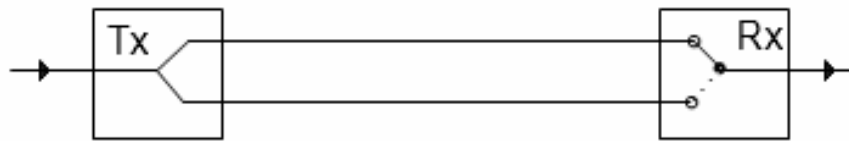

Figure 8. Principle of 1+1 MSP.

In 1:1 MSP the traffic is sent through the working link only, and in event of failure both ends must switch to use the dedicated protecting link. However, in this case, protecting link can be used to carry low priority traffic when the link is in standby, but this traffic will be discarded instantly if the switching is initiated. One standby link can also protect multiple working links, which is referred as 1:N MSP. (ABB 2008b: 79–80.)

MSP offers protection to the traffic between two adjacent nodes, but this traffic is lost if one of the two nodes fails. Another limitation in MSP is that the working fiber and the protecting fiber must be physically in different ducts in order to avoid simultaneous damage to the fibers. However, MSP can be applied to rings, which overcomes these limitations naturally.

Multiplex section shared protection ring (MS-SPRing) is a MSP scheme designed especially for ring topology. In MS-SPRing, two fiber rings are set. Working traffic is sent in one direction (e.g. clockwise) and the other direction (counter-clockwise) is reserved for protection. The reserved fiber is used for protection only if the working route fails, thus it can be shared in normal state with low priority data traffic or path protection schemes, utilizing the capacity more efficiently. (ABB 2008b: 80–87.)

Principle of MS-SPRing is shown in Figure 9. Picture on the left illustrates the original situation where traffic is sent over the working line. After detecting the failed line between nodes two and three, node two routes the traffic to the protecting line that operates to the opposite direction of the ring (picture on the right).

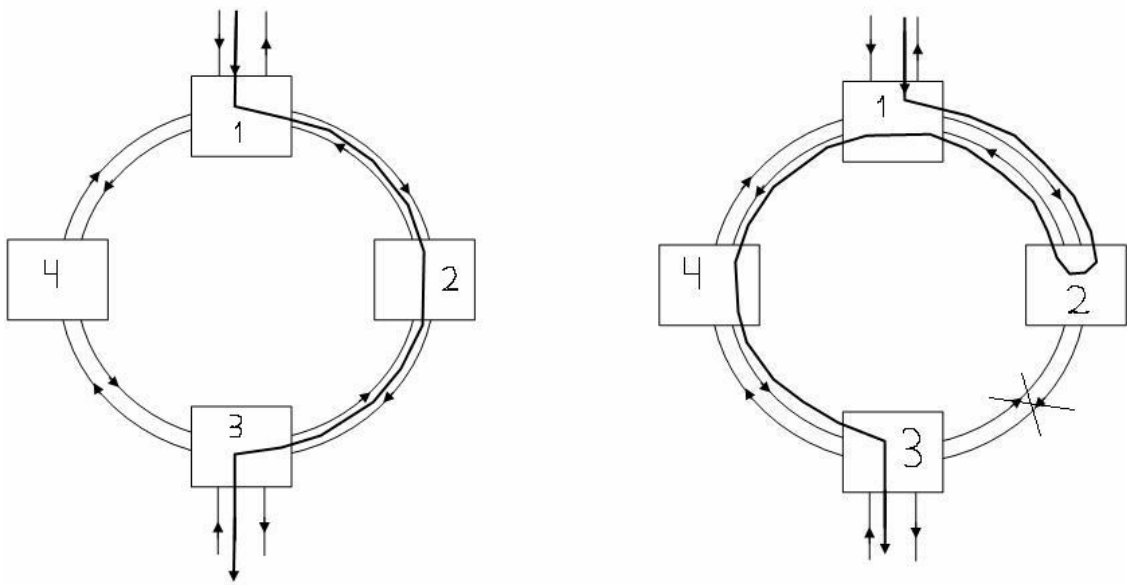

Figure 9. Principle of MS-SPRing (Renfors 2007: 28).

2.7.5. Ethernet over SDH

SDH was originally designed for transferring voice traffic with fixed bandwidth, and so it is not optimized for highly dynamic IP data traffic. As the standard Ethernet bit rates (10/100/1000 Mbps) differ from the SDH bit rates (see Table 2), Ethernet-frame transported inside one or more STM-frames causes transmission capacity wasting. However, recently published Ethernet over SDH (EoS) standard provide methods to map variable length Ethernet traffic to synchronous stream of data that can be then transported efficiently inside the virtually concatenated VCs. (Sivarajan, Kumar & Jishnu 2006.)

3. UTILITY AUTOMATION SYSTEMS

This chapter presents briefly the common automation systems used especially in power transmission and distribution systems. Accordingly, the aim is to review the systems from the communications point of view to give a description about the used communication protocols and methods that are expected to be supported by the underlying communications systems.

3.1. Supervisory control and data acquisition

Supervisory control and data acquisition (SCADA) is a real-time distributed data system used by utility companies and industry to monitor and control their plant equipment, processes and resources. It applies to substation automation, heating plant automation, control of electric and district heating networks and other industrial processes. SCADA can also associate with related data systems, such as distribution management systems, automatic meter reading and customer information systems. (ABB 2000: 406–408; Haji, Lindsay & Song 2005: 172.)

SCADA can be seen as an interface between operator and the equipment that is connected directly to the process. Figure 10 portrays an example SCADA system, where remote terminal units (RTU) and programmable logic controllers (PLC) are connected to the field level equipment, e.g. relays, meters, sensors and actuators, to collect measurement values and status data from the equipment and to perform automatic control actions. Gathered data is then sent via communication links to SCADA master station where it is processed, stored and possibly sent to other systems. Master station displays alarms and other notifications that require actions to operator and sends operator's action commands and new set points back to the equipment.

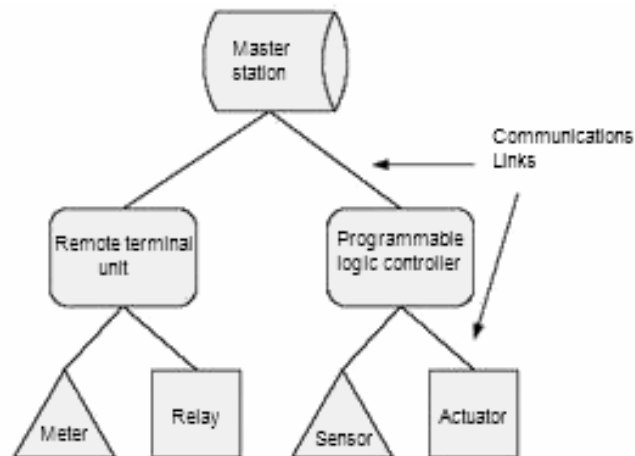

Figure 10. Example SCADA system.

SCADA applications have historically used a wide variety of communication protocols. Traditionally SCADA systems were closed systems using serial and vendor-related protocols and communications, though some of the protocols have become standards over the years. Fixed analogue circuits and modems have been used for data transmission between master station and RTUs thus guaranteeing communication path with adequate bandwidth and short and consistent transmission delays. This conventional method has been satisfactory for many years but has become outdated and unsuited to today's requirements. (Haji et al. 2005: 172; Mak & Holland 2002: 305.)

In recent years, SCADA systems have adopted broadband standards, such as Ethernet and TCP/IP, which has driven the SCADA systems towards open and more integrated and flexible network in terms of expansion, reconfiguration and higher bandwidth potential. In fact, this has reduced the number of protocols used in SCADA communication and led to the emergence of open SCADA protocols that are designed to operate especially over TCP/IP and Ethernet. The most widely used standard protocols today are DNP3 (distributed network protocol), IEC 60870-5-104 (International Electrotechnical Commission) and MODBUS, though some vendor-specific protocols are still being developed as well. (Mak & Holland 2002: 305-307.)

Traditional SCADA communications between RTUs and master station were usually implemented by single- or multipoint lines, which was costly and inefficient. With IP-

enabled SCADA systems, it is possible to push the communications processing closer to the RTUs and terminate these separate lines by communications equipment in the field and bring a single communication line to the control center where the data is extracted by the SCADA servers. Today, vendors are even producing RTUs that are capable of connecting to Ethernet networks without having to use an intermediate communication device between RTUs and SCADA masters. (Belagur & Schmidt 2008: 2; McClanahan 2003: 35–36.)

SCADA systems are usually hierarchical and have connection to upper-level. E.g. in distribution automation concept (ABB 2000: 401), one SCADA system is placed on local control room at each substation and another SCADA system at the control center. The use of open standards makes it also possible to have SCADA systems from different manufacturers, as well as third party peripherals devices (McClanahan 2003: 29–32).

3.2. Substation automation

Substation automation (SA) is a system that enables power companies to give local control operations to the equipment installed in the substation as well as to remotely monitor it from the control center. SA is also used to protect the network equipment and to collect valuable real-time information about the network's condition. Usually equipment used for substation automation and protection are RTUs, PLCs, protection relays, meters, sensors and other intelligent electronic devices (IED). These IEDs are installed in strategic locations for automatic protection and data collection functions of the SA equipment. (ABB 2000: 409–410; Gupta 2008: 462.)

The SA system is closely related to SCADA, as its one function is getting data out of the substation and into the SCADA system. Traditional SCADA protocols have been used in data communication between SCADA servers and RTUs as well as interaction among the IEDs. However, variety of used protocols has caused interoperability

problems between the IEDs supplied by different vendors and has also led to protocol translations when collecting data from different IEDs. (Ackerman 1999: 274–275.)

Ethernet technology has found its way also to substation automation. In many cases, control center communications has been migrated to Ethernet. Modern SA system also has an Ethernet-based local area network (LAN) to support the local automation functions and peer-to-peer communications between the IEDs in the substation. In fact, emerge of the world wide IEC 61850 standard, designed especially for SA, has considerably improved interoperability among the IEDs supplied by different vendors. (Ackerman 1999: 275; Kirkman 2008: 598–599.)

Despite the fact that Ethernet has become common standard in substation communication, there are still many legacy devices communicating in their native serial protocol and interface. However, migration to Ethernet based communication infrastructure enables the evolution of IP enabled IEDs, which allows SCADA masters to remotely communicate with the IEDs, thus simplifying the hardware configuration and eventually eliminating the function of substation RTU. (Belagur & Schmidt 2008.)

3.3. Protection systems

Protection relays are used in electrical networks to protect the power systems against faulted conditions. Relays monitor the network's state and in the event of a failure, they switch off the faulted part of the network by controlling breaker equipment. The isolation must be done as quickly as possible to prevent the electrical cables and plant items from damage, and to enhance the stability of the power system. (Richards, Potts & Best 2004: 722.)

3.4. Teleprotection

Besides protection relays use local measurement data to make autonomous decision whether to break the circuit or not, relays can interact with remote relays and use their information for a more secure trip decision. This kind of protection system that uses communications to transfer measurement information and trip signals between different protection systems is called teleprotection. It is used especially in transmission systems to provide secure and uninterrupted supply of electricity. (Richards et al. 2004: 722; Usta, Redfern & Bayrak 1998.)

As a time-critical application, teleprotection systems require very fast transmission times. Moreover, privacy and security has been of great importance, because the teleprotection signals can be direct trip commands without any supervision to the correctness of the signals at the receiving end. These are the main reasons why private communication lines, such as leased telephone lines, power line carriers and fiber optics has been dedicated for teleprotection. (Richards et al. 2004.)

4. ABB'S MULTIPLEXER PRODUCTS

ABB's FOX-products form an advanced product family for utilities communication solutions that has history of many decades (ABB 2006). The FOX515-family is designed for harsh electromagnetic environments. It provides electromagnetic compatibility (EMC) protected high-speed fiber-optic network infrastructure that covers versatile SDH multiplexers with various access and transport features for utility automation applications and standard telecommunication services as well. Additionally, the family provides configure and management software tools for centralized remote operation and maintenance purposes.

4.1. FOX515-family

The main product of the family is the FOX515, see Figure 11, multiplexer. With full range of units supporting access- and transport-features up to STM-4 level, FOX515 is the key element of a modern FOX-based network solution. FOX515 is discussed in detail in the following chapters.



Figure 11. The FOX515 (ABB 2007).

FOX512, see Figure 12, is a compact version of FOX515 and so designed to fit solutions where space is a premium. It covers all the same features as FOX515, but due to its size, fewer interface units can be used, which limits the scope of use and future extensibility considerably. (ABB 2006.)



Figure 12. The FOX512 (ABB 2007).

FOX515M, see Figure 13, stands for minimal version of FOX515 with STM-1 connection. As a space-efficient device, it has limited number of ports and therefore is optimal for small utility sites where traffic is legacy data and LAN-based. (ABB 2006.)



Figure 13. The FOX515M (ABB 2006).

FOX515D, see Figure 14, is optimized for applications related to power networks at distribution-level, where traffic is LAN-based and the amount of required interfaces is relatively low for each station. Traffic rates are supported up to STM-4 level. (ABB 2006.)



Figure 14. The FOX515D (ABB 2006).

FOX515X, see Figure 15, is a space-efficient extension that is used to upgrade lower level FOX network capacity up to STM-16. Comprehensive TDM and Gigabit Ethernet service units are provided as well. (ABB 2006.)



Figure 15. The FOX515X (ABB 2006).

FOX515T, see Figure 16, is the high-end multiplexer, and with the very high capacity and fully redundant hardware, it is the choice for transmission networks core. It offers multirate SDH transmission up to STM-64-level, which takes also advantage of WDM technology. (ABB 2007.)

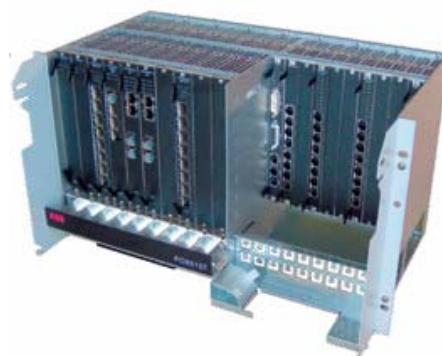

Figure 16. The FOX515T (ABB 2006).

4.2. Universal Configuration Software Tool

The FOX family covers also configuration and management programs for the FOX multiplexers and systems. These programs are designed for Windows operating systems. The Universal Configuration Software Tool (UCST) is mainly used to configure FOX515, FOX512 as well as FOX-U multiplexers. It covers also minor management features, such as alarm lists and fault logs from the FOX515 where the UCST is connected to. (ABB 2008a.)

4.3. FOXMAN

FOXMAN is graphical remote management software for FOX-based networks. It covers monitoring and control functions for communication connections, network elements as well as for individual channels and signals. FOXMAN is also capable of supervising third-party network elements, thus providing monitoring for the overall communication network. Besides being used locally from a control center, FOXMAN management operations can be done remotely. To provide a secure support access to the FOXMAN, remote connections can be established via virtual private network (VPN) over corporate intranet or the Internet. (ABB 2006.)

5. FOX515 CHARACTERISTICS

This chapter concentrates on the FOX515 and its main features. Accordingly, the purpose of this chapter is to describe the base technology and the general features of the device. Furthermore, the FOX515 configuration and management operations are reviewed. Finally, the protection features for the FOX515 units and network traffic are considered.

5.1. Platform

The FOX515 platform is made up of EMC protected subrack, which comprises 21 slots for units designed especially for FOX515. Additionally, FOX515 is compatible with units designed for the obsolete PDH multiplexer FOX-U. In order to operate, FOX515 needs two basic units: the control unit and the power supply unit (PSU). Naturally, the basic system needs to be complemented by the appropriate units, as required by the applications.

As a controller, the control unit is not directly involved in processing network traffic. Its role is to carry out especially management functions. It provides the physical management communication interfaces and handles all the management communication between operator and between other network elements. The control unit also provides alarm interfaces and handles the network synchronization. (ABB 2007.)

FOX515 offers access and traffic units with various interfaces for utility automation applications and telecommunication services. Access interfaces for traditional telephony, integrated services digital network (ISDN), legacy serial data, optical and electrical teleprotection and Ethernet are widely supported. On transport side there are optical PDH and SDH interfaces, electrical PDH interfaces and high bit rate digital subscriber line (HDSL) trunk cards available as well. (ABB 2007.)

5.2. Bus-structure

FOX515 has a precise bus-structure, which defines the supported bus types for each unit and the possible slots where the units may be installed. E.g. the main control unit is always placed in the slot 11, contrary to the PSU that can be placed basically in all available slots. Bus types that are used in FOX515 are U-BUS, P-BUS and S-BUS.

The U-BUS has no dedicated cross-connect, but it is a tributary to the PBUS cross-connect. Its capacity is fairly limited; 8 channels, each up to 2 Mbit/s, and associates with 64 kbit/s signals. The U-BUS is used especially with modern teleprotection units, though it also provides compatibility with the FOX-U networks by supporting older units designed for the FOX-U. (ABB 2007.)

The P-BUS offers direct access for the P-BUS units and covers wide range of PDH interface signals from 64 kbit/s to 2 Mbit/s. It handles also the tributary signals coming from the U-BUS and the S-BUS to the cross-connect. The P-BUS built-in cross-connect is implemented with capacity up to 128 channels with 2 Mbit/s each. (ABB 2007.)

S-BUS offers the highest capacity and handles the SDH traffic at STM-1 and STM-4 levels. Actually, FOX515 has two individual S-BUS sectors, which each has the capacity of two VC-4s. Each sector supports two SDH units, which can aggregate SDH traffic from the S-BUS and terminate VC-12 traffic between P-BUS and S-BUS. (ABB 2007.)

5.3. Configuration

Configuration of the FOX515 is done with the UCST program. The configuration files can be created either offline and downloaded later to the FOX515 or online and progressively downloaded using local or remote connection to the control unit. Proper configuration can be achieved by following certain programming steps. These steps go through the configuration in stages including the most important stages: cross-connections, synchronization and installation.

5.3.1. Cross-connections

Cross-connections involves mapping of the interconnections between different channels. It is used to route each tributary signal up to the virtual container level. A large network system comprises many cross-connections and they must be created one by one. Also the complex network topology and used protection schemes can cause problems already in the system design phase as well in the mapping phase. Therefore cross-connection is the most difficult and the most time-consuming part of the configuration.

5.3.2. Synchronization

Synchronous network requires excellent synchronization between the network elements. FOX515 has a relatively stable internal quartz-crystal clock as a default timing source. However, for primary reference clock (PRC), more precise source is preferred. (ABB 2008a.) ITU-T (1997: 7) recommends that the long-term network clock accuracy should be 1 part in 10^{11} or better, which is derived from the acceptable occurrence of a slip that is once in every 70 days. This level of stability can be generated only by atomic clocks, such as the global positioning system (GPS).

In SDH networks, the timing sources can be prioritized by using synchronization status messaging (SSM) and quality levels. The quality level of certain source is distributed to the network as an SSM byte in the section overhead of the STM-frame, so each FOX515 can decide which source to use. If the main clock is unavailable, the second highest clock, usually the internal one, is enabled (Yahong & Hequan 1998: 1–2; ABB 2008a.)

Figure 17 portrays an example of synchronization in a ring network, where PRC is designated with the highest priority level, from which the other network elements derive their clock directly or indirectly via the others. In the event of a network failure, such as fiber break, synchronization data can be sent the other way around.

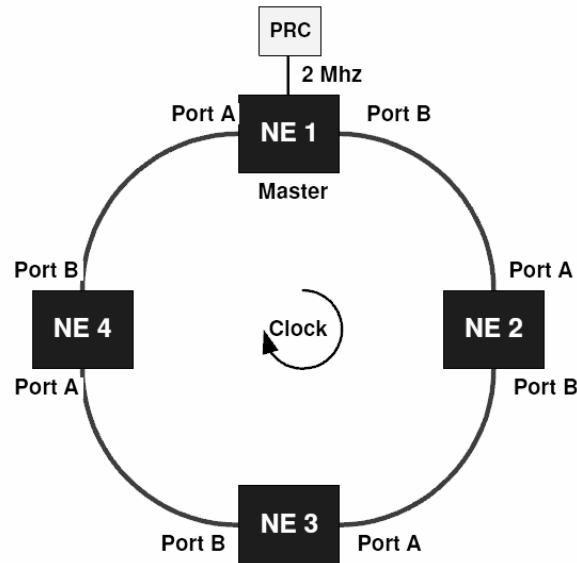

Figure 17. Example of network synchronization. (ABB 2008a).

Again, complex network brings on challenges to the designing. Each time the clock is passed through the quality of the clock is degraded, although the quality level remains the same. (ABB 2008b: 170.) So in long synchronization chain, the clocks real quality will not be as good as it seems.

Certainly FOX515 network can be equipped with multiple clock resources that can be used in parallel. Even though this is more expensive synchronization solution, it is more accurate and safe way in the event of interrupted connections.

5.3.3. Embedded software

Before units can be enabled, each unit needs its own embedded software (ESW), commonly known as firmware. ESW-file is delivered first to the control unit and stored into control unit's database. After the delivery, the file is installed into the unit's flash memory. ESW installation is also used when an ESW is updated to a newer version. ESW delivery is used for the P-BUS and S-BUS units. In U-BUS, ESW is stored into unit's memory in the manufacturing phase and cannot be installed or updated via UCST. (ABB 2008a.)

5.4. Network topologies

FOX515 can be operated as a network element basically in any type of network. Topologies e.g. linear, star, ring and meshed are supported, as well as their mixed variations, although complex network topology can lead to bandwidth allocation problems. Ring is the most preferred topology to use due its natural resiliency and efficient use of bandwidth. However, to guarantee performance rates defined by standards, ring topology has some restrictions, e.g. node amount is limited to 16 and ring circumference to 1200 kilometers. (Skendzic & Moore 2006: 643–644; ITU-T recommendation G.841: 47–48).

5.5. Network management

Integrated network management is one of the most important features that SDH can offer. It means that management messages can be sent over the same physical connection together with operational data. The STM frame structure provides centralized remote management for network elements on an end-to-end basis. In each STM-frame, two embedded data communication channels (DCC) are dedicated for transporting management data between network elements and management system like FOXMAN. These in-band channels are very convenient from the maintenance aspect as there is no need for expensive external management communication network. (OpenCon Systems, Inc. 2003.)

In a FOX515 network, DCC messages are sent and routed as IP-based packets and handled by the central units. Therefore the DCCs can be accessed from each network node and the network can be managed from different locations.

One of the main goals in the development of SDH was compatibility with different fiber-optic products, which indeed is achieved at least at the operative structure level. In addition, structure of the network management messages is standard and irrespective of vendor, which allows to supervise multiplexer equipment from different vendors with

the same management system. However, there is no clear definition of the message sets to be carried, so the real interworking between multiplexers of different manufacturers is inconsistent. (OpenCon Systems, Inc. 2003.)

5.6. Alarms

The alarms in FOX515 systems are continuously supervised to detect signal losses, synchronization faults and other changes on the alarm states. Besides the alarms are displayed by the software, each FOX515 unit has alarm indication lights on the front panel. The central unit has also output signals that can be connected to external alarm devices or to a local RTU in order to integrate the FOX alarms to SCADA system. (ABB 2008a; Weiss 2009.)

FOX515 supports simple network management protocol (SNMP) standard, which makes connection to higher-level network management systems possible. In addition, this enables monitoring of SNMP-based devices through an object linking and embedding for process control (OPC) server, which makes it possible to integrate FOX alarms as well as management with SCADA systems. Though, for the assistance in monitoring and management operations, network management system such as FOXMAN is still needed. (Weiss 2009.)

5.7. Traffic protection

Reliable communications network is fundamental to the utilities operation. In harsh environment, network equipment is exposed to damage. Hence availability of the network must be guaranteed e.g. during a fiber break or an equipment failure. Therefore resilient and fault tolerant network that can restore the traffic automatically in the event of failure is of great importance.

APS schemes that SDH technology offers can be implemented in FOX515-based networks. As there is no one best scheme for protection, network design has a central position when the schemes are considered. An MSP scheme is typically choice for whole trunk network traffic protection while path protection is used to protect precise channels. Efficiency can often be achieved with protection interworking (Edwards 1998).

5.8. Hardware protection

The operation-critical units, control unit and PSU, can be installed with redundant units. If a failure occurs in the working control unit or PSU, the protecting one takes of its place. These units like all the FOX515 units are hot swappable, so a failed unit can be replaced without more interruptions to service. This goes for the optical connectors as well.

Actually, redundancy is implemented in slightly different way in each case. The main control unit and the redundant control unit are separated into a working unit and a standby unit, whereas each installed PSU is working and feeding power together. Therefore the PSU redundancy must be planned in such a way that other unit or units can handle one's load in event of a failure. The UCST has a convenient power indicator panel to ease this design.

Hardware protection can be adopted along with traffic protection. Path protection schemes can be implemented using two separate units for the duplicated transmission. Similar method can be obtained with MSP schemes, when protecting traffic is routed via two different units to provide hardware protection. Moreover, working and protecting STM-traffic units can be installed on different S-BUS sectors to avoid simultaneous malfunction in event of a failure on the backplane bus.

6. APPLICATIONS WITH FOX515

The advantage of SDH as an underlying communication technology is the ability to transmit signals with strict timing constraints, such as protection signals, in parallel to bursty packet-switched Ethernet-traffic. With the large range of supported access interfaces together with the high capacity, FOX515 communication system is suitable for utility WAN that can integrate the utility company's operational and administrative application traffic between sites, between offices, between cities and throughout a whole region or a country. In this chapter, these important applications for the companies' are reviewed.

6.1. SCADA

FOX515 offers solutions to run IP-based SCADA information over a FOX515 communication network. By means of the EoS supported Ethernet units with bridging, switching and routing services, SCADA-traffic can be transported over FOX515 network up to Gigabit level. SCADA equipment communicates with SCADA master station via standard LAN-based protocols, such as IEC-60870-104, DNP3 over TCP/IP, and can therefore be located anywhere the IP-network is available. Networked RTUs are equipped with Ethernet interfaces that connect them to a station- LAN at their location. This allows the master station to communicate directly with the RTUs via IP over a FOX515-based WAN that connects the LANs at the remote sites and at the control center.

In addition, to protect earlier investments, serial communication based devices can be connected to data interfaces designed for legacy serial protocols or to gateway equipment that can transmit serial SCADA data over TCP/IP. This provides a low cost method for integrating existing serial RTUs and other IEDs into the FOX515 communication system.

6.2. Substation automation

Ethernet-based LANs have become an integral part of power system communications. As the amount of collected data is increasing at the substations and the automation is getting more and more involved with other substations, intersubstation communications is necessary to satisfy different needs presented by SCADA, engineering and maintenance access, as well as power system protection applications.

FOX515 offers a reliable and secure utility-wide network that can be used to interconnect Ethernet-based substation LANs. By means of integrated IEC 61850-grade Ethernet, FOX515 units are convenient solution to interconnect substations and to communicate with the SCADA masters at the control center.

6.3. Teleprotection

Traditionally, in distance line and breaker failure protection, command signals between protection relays are transported via external teleprotection equipment (Richards et al. 2004: 722). However, as seen in Figure 18, FOX515 equipped with the teleprotection and binary unit (TEBIT) can be connected directly to protection relays replacing the need for independent equipment between the relays and the communication system.

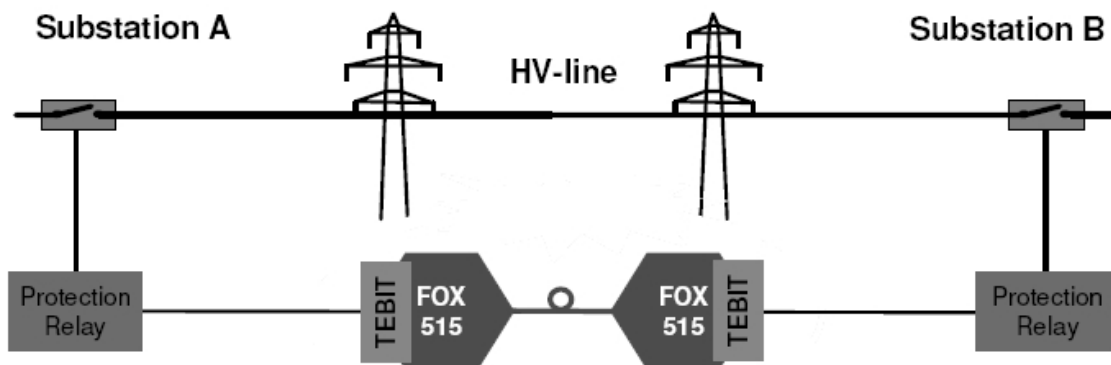

Figure 18. Teleprotection system with TEBIT (ABB 2008a).

With less equipment and interface chain, FOX515 communication system provides increased reliability to the line protection, as well as faster processing and switch over times. Correct operation and channel healthy can be verified by continuous loop tests that are used to monitor propagation delays for each command channel as well. (ABB 2008a.) This feature is also used to measure the performance of TEBITs signals in Chapter 8.

When considering line differential protection schemes i.e. phase comparison and current differential, measurement information is transferred between the relays via dedicated signaling channel for the measurand comparison to take place at the receiving end (Richards et al. 2004: 722). FOX515 has various interfaces, both electrical and optical that allows direct connection with relays. Serial data interfaces are also provided to connect legacy protection relays thus supporting integration of the existing teleprotection system to the FOX communication network. (ABB 2008a.)

6.4. Voice communication

Traditional telephony is still indispensable tool in operational system management, as service procedures between substations and between control center and substations are usually executed by telephone. Naturally, telephony is needed at offices and control centers for administrative purposes. Private and public switched telephone networks, direct hotlines, as well as cellular networks have commonly been used as solutions for companies' voice communications. (Ericsson 2002: 346–347.)

Operational service phone and office telephone traffic, however, can be integrated to FOX network. FOX515 supports various telephony interfaces that can be used to connect existing private automatic exchanges and subscriber lines for the internal voice communication and naturally to the public telephone networks. Moreover, telephone communication has been migrating towards voice over IP (VoIP) services, which takes full advantage of the digital network. (ABB 2008a; Skendzic & Moore 2006: 641.)

Service phone can be executed also by the means of the SDH system design. The STM-frame provides dedicated bytes that can be used to carry order wire voice channels. Two bytes, E1 and E2 are used to carry PCM voice signals between regenerators and between multiplex section nodes. In addition, the two DCC network management channels can be used to transport voice traffic based on VoIP. In fact, by using the connectionless IP-technology, connectivity between any two points in the network is more convenient, thus providing complete coverage to every network element irrespective of topology of the network as long as the network is operational. (Pan 2008.)

6.5. Video applications

As the supervision of utility networks is getting more and more centralized, there is an increasing demand for remote security monitoring and remote-controlled video surveillance on the unmanned substations and sites. Visual information from the remote sites can be used e.g. for access control and weather reports. In addition, video conference is increasingly used as a communication method between control centers and offices. (Ericsson 2004: 93; Mak & Holland 2002: 308.) Thus, transmission of these bandwidth consuming video applications requires broadband connections. With FOX515, video applications can be run over IP conveniently among the other Ethernet-based traffic.

6.6. Data services

In most utilities, data network between offices are usually based on costly leased lines (McClanahan 2003: 34). When FOX515-based network is installed, Ethernet services are supported to interconnect separate LANs at offices, control centers and sites to a single utility WAN. Hence, administrative office traffic can be transferred over the WAN and number of the leased lines can be reduced. Moreover, corporate network will not only be available at the offices, but can be also accessible from remote sites, which

brings business data such as file sharing, electronic mail services, corporate intranet and the Internet down to the field level. (Ericsson 2002: 345.)

Modern communication system offers an entrance to commercial telecommunications market. If the whole capacity of the utility network isn't reserved for utility applications, the company can provide data services such as Internet access to third parties over the utility WAN. Thus network security must be considered carefully when allowing field and third-party access to the utility network, and especially when the network is connected to the Internet. However, these security issues are beyond the scope of this thesis.

7. PERFORMANCE ANALYSIS

Because of the operational nature of the automation systems, such as SCADA and teleprotection, underlying telecommunication system must be very reliable and continuously available. Moreover, it is important to ensure that the mission-critical applications are not blocked by general and less crucial applications. Before utilizing SDH network to transport these real-time signals and application data, some performance issues must be considered.

7.1. Availability

Availability of a communication system is defined as the probability that the system is able to provide service. Availability estimation takes into account the survivability of the system, failure rates and repair times of its components. Accordingly, it reflects the average quality of service, which a system operator experiences on a day to day basis. (ABB 2008b: 69; Edwards 1998: 203.) Availability is calculated according to the equation:

$$A = \frac{MTBF}{MTBF + MTTR}, \quad (1)$$

where $MTBF$ (mean time between failures) is mean operating time between two consecutive failures and $MTTR$ (mean time to repair) a mean time required to repair the failure (Rados, Sunaric & Turalija 2002:287).

Availability can be also expressed as unavailability U that is the complement of A as follows: (Rados & al. 2002:287)

$$U = 1 - A = 1 - \frac{MTBF}{MTBF + MTTR}. \quad (2)$$

To illustrate system performance more practical, unavailability is often expressed as MDT (mean down time) in minutes per year, i.e. (Rados & al. 2002:287)

$$MDT = 365 \cdot 24 \cdot 60 \cdot U [\text{min/ year}]. \quad (3)$$

As SDH network generally consists of cable sections and nodes, the availability of a whole system is calculated from the availability of its separate components. The availability A_s of a serial structure system which includes n network elements is: (Rados & al. 2002:287)

$$A_s = A_1 \cdot A_2 \cdot \dots \cdot A_n = \prod_{i=1}^n A_i \quad . \quad (4)$$

The equation shows that longer and unprotected element chain leads to lower availability, and a failure on any element causes unavailability of the whole structure. Respectively, the system unavailability is: (Antonopoulos, O'Reilly & Lane 1997: 668)

$$U_s = 1 - \prod_{i=1}^n (1 - U_i). \quad (5)$$

Considering that in practise the unavailability rates for different system components are very small, a very good approximation for the system unavailability is the sum of unavailability rates of the components: (Antonopoulos & al. 1997: 668)

$$U_s = \sum_{i=1}^n U_i \quad . \quad (6)$$

By contrast, the availability A_p of a parallel structure of n branches is: (Antonopoulos & al. 1997: 668)

$$A_p = 1 - \prod_{i=1}^n (1 - A_i), \quad (7)$$

Now, the more branches is used, the higher availability is obtained, and so unavailability of the structure can result only from concurrent component failures. This structure describes the situation where the traffic has one or more protection routes. The system unavailability is respectively: (Antonopoulos & al. 1997: 668)

$$U_p = \prod_{i=1}^n U_i . \quad (8)$$

As SDH network can be seen as a combination of components connected in series and in parallel, availability and unavailability for each network element and system can be calculated by using these equations described above. (Antonopoulos & al. 1997: 668.)

Usually, availability demands for utility communications systems are given in percentage of the time per year that the system must be functioning. The demands may vary depending on the scope of the system and the type of traffic to be carried by the network, thus the more subsystems involved the greater need for the network availability is given. E.g. according to Mak & Holland (2002: 305) and Mraovic & al. (2007: 613), demanded availability for communication links between master station and RTUs carrying critical SCADA information is at least 99,995 %.

In general, SDH is very reliable, and can provide availability rates over 99,999 % (Leroux & Giguère 2007). To achieve these high rates in FOX515 network, the network must be resilient. The network is resilient if there is no single point of failure between any two nodes. Moreover, to increase the survivability of the network and so the availability, hardware protection should be implemented as well. Certainly, efficient management and monitoring system is also required to guarantee quick reconfiguration in fault situations.

7.2. Response times

Real-time applications have strict timing constrains that are usually given in form of end-to-end deadlines. Especially in teleprotection systems, commands should be transported within a very short time frame. The protection operation shall function within approximately 100 ms including the different actions, such as fault detection, command propagation and line breaker delays. Hence, the maximum allowed time for the command transmission between the teleprotection equipment is in the order of 12–20 ms. (Ericsson 2002: 346.)

In SDH, the response time for protection switching is defined by the ITU-T standards to 50ms at tops, which has been considered as very fast compared to other competing options, especially in ring topologies. Additional vendor-specific enhancements, e.g. for teleprotection, is also available. (ITU-T recommendation G.841: 47–48.)

As for SCADA traffic, typically allowed transmission delay tolerance is 1–5 s. Because of the short and very consistent transmission delays that SCADA traffic requires, it is not ideally suited to be transported over Ethernet, where transmission delays can vary significantly. However, Ethernet technology provides methods for quality of service (QoS) that can be obtained in SDH-based networks. Ethernet bandwidth can be dedicated for individual channels using virtual local area networks (VLAN). Each VLAN is prioritized, and the highest priorities are given to the most critical applications to utility's operations, thus guaranteeing timely and secure responses for these primary applications even if the Ethernet network traffic is congested by video and other bandwidth consuming data applications. (Haji et al. 2005: 172–174; Mak & Holland 2002.)

Recent improvements in the restoration algorithms have also lowered the response times of pure Ethernet, in particular with ring topology, from multiple seconds down to few milliseconds per hop between adjacent network nodes, which is indeed competitive with SDH. However, the advantage of SDH is that the response time is predictable, because of the TDM technology that assigns time slots fairly and assures bandwidth for each dedicated tributary channel. Consequently, this allows SDH networks to autonomously transmit teleprotection signals and other fixed TDM-traffic in parallel to bursty packet-switched Ethernet-traffic. (Skendzic & Moore 2006: 643–644.)

7.3. Communications requirements

Utility communications equipment is usually exposed to severe electromagnetic interferences, which can lead to disturbed signals and cause equipment to maloperate. Therefore high capacity fiber-optical links are often specified as the only

communications medium that can deliver the requested noise-immune bandwidth to such harsh environments. In fact, optical fibers can be integrated into the ground wires over the power lines. Moreover, SDH fiber-optical links provide long transmission distances without the need for repeaters. Despite the fairly high costs and long time to install and repair, the advantages make optical fibers the most important communications medium today. (Aggarwal & Moore 1994: 100; Mak & Holland 2002: 305.)

Optical fibers do not only meet the today's capacity requirements, but can also handle capacity that will be required tomorrow. By means of DWDM techniques, expandability of the fiber capacity is very high. In addition, microwave radio links offer an advantageous alternative for optical fibers to transmit SDH traffic in difficult terrain, and hence can be utilized in designing the optimum communications network architecture.

8. EXPERIMENTS AND CALCULATIONS

In order to verify performance figures stated in the previous chapter, a testing environment was set up. The main objectives with the implemented test system were to measure teleprotection operating times with the TEBIT and to estimate the availability of the system.

8.1. Test system arrangements

The built-up test system is visualized in Figure 19. The system was implemented within the limits of available equipment at the testing environment of SAS and consisted of two similar FOX515s. Each FOX515 were equipped with units for teleprotection, telephone, serial data and Ethernet traffic, as well as termination and aggregation units for STM-1 traffic. In addition, redundant control unit and PSU were utilized. For the management connections, RS-232 and LAN connections were established to both FOX515s, and DCC channel was also used to demonstrate the remote configuration and management operations.

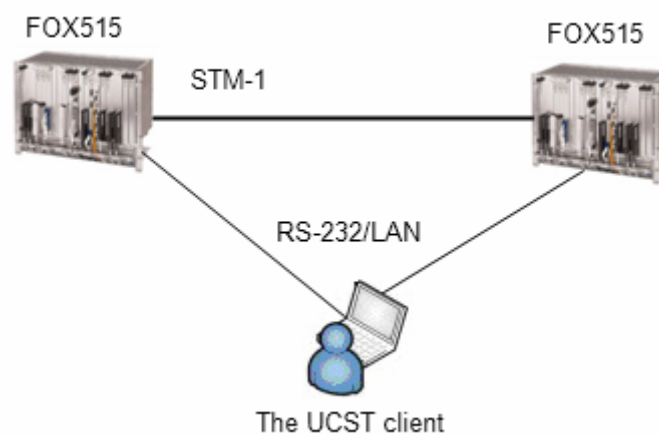

Figure 19. Test system overview.

8.2. Teleprotection operating times

The aim of the experiment was to measure teleprotection operating times for the test signals between the two TEBIT units. The measurements were executed by using the integrated loop test application of the UCST. The loop test is based on equal propagation delay in both directions, though the measurement result is the delay time in one direction. (ABB 2007.)

The test connection was implemented with two parallel command channels using point-to-point transmission between the TEBITs. One channel was dedicated for security optimized commands that are used with direct tripping signals. The other channel was reserved for speed optimized commands, such as permissive tripping.

In Table 3, the results for the measurements are shown. As it can be seen from the table, the delay for the speed optimized signal is shorter than for the security optimized signal. This is due the fact that direct trip commands must be processed more carefully to assure that any noise on the signalling channel isn't seen as being a valid command signal. In other words, no correctness checking is performed to the direct trip signal after the sending decision is made, while with permissive signals, each command is checked before the protection operation is made at the receiving end. Nevertheless, the results support the short operation times required from the connection between the teleprotection equipment, and consequently are within the range of typical TEBIT operating time that is 2,8–8,2 ms (ABB 2008a).

Table 3. TEBIT loop test results.

Signal type	Propagation delay time [ms]
Speed	3,50 ± 1
Security	6,25 ± 1

8.3. System availability

Availability calculations for the test system is done using the equations introduced in the previous chapter, and the following estimations for FOX515: Mean failure rate for each module is set to be over 20 years and the average repair time (MTTR) that a maintenance engineer may need to find the error and replace the defective module is 4 hours (Weiss 2009). So the MTBF in hours is

$$20a \cdot 365 d/a \cdot 24 h/d = 175200h.$$

Consequently, according to the equation (1), the availability A_M of a FOX515 module is over 99,997%, calculated as follows:

$$A_M = \frac{175200}{175200 + 4} = 0,999977.$$

In proportion, the unavailability U_M for the modules is calculated by the equation (2) as follows:

$$U_M = 1 - \frac{175200}{175200 + 4} = 2,283 \times 10^{-5}.$$

To estimate the availability for the test system, each module that is affecting the traffic in an end-to-end connection must be taken into account. Figure 20 represents a block diagram of the modules that are affecting input/output traffic in the one terminal FOX515. As the setup of both test FOX515s were identical, the diagram is in reverse order in the other end. Hence, the calculated availability is, in fact, for a specific channel, though it can be applied for different channels with similar connection structure.

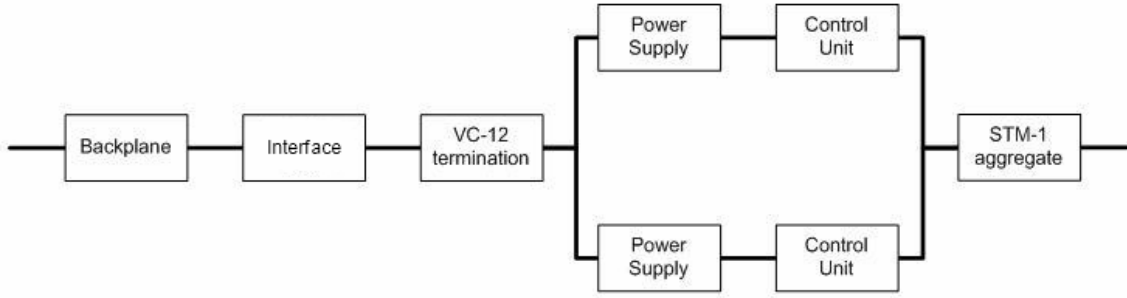

Figure 20. Block diagram of the traffic affecting modules.

The most convenient method to calculate the availability for the test system is to use unavailability instead. Unavailability of the system U_S is the sum of the unavailability U_F rates of the two FOX515s that can be calculated by using the equations (6) and (8). The calculation is simplified by ignoring the unavailability of the optical fiber that is almost non-existent in this test environment and due the short length. According to the generated formula below, the availability A_S of the test system is approximately 99,98%;

$$A_S = 1 - U_S = 1 - (U_F + U_F) = 1 - 2U_F =$$

$$1 - 2[U_M + U_M + U_M + (U_M + U_M)(U_M + U_M) + U_M] = 0,999817,$$

which equals, according to the equation (3), the mean down time of

$$MDT = 365 \cdot 24 \cdot 60 \cdot (1 - 0,999817) = 96 \text{ min/ year.}$$

The quite moderate availability result for an SDH-based system indicates the lack of protection schemes used in the test system. In addition, the long module chain connected in series affects the system by lowering the availability considerably. To improve the system availability, the chain should be shorten, which in this case could be done using protective unit for the STM-1 connection. As in contrast, the availability of the test system would be over 99,99 % with these modifications to the equipment. Moreover, later type STM units can handle both the VC-12 traffic termination and the aggregation to STM-level, which would also shorten the module chain if implemented

in both ends. However, to achieve system availability rates close by the reported “five nines”, redundancy should be adopted to the interface unit level or down to board level with dual terminal FOX515.

9. CONCLUSIONS

Multiplexer technology is generally well suitable for the underlying communications solution in utility automation systems. Highly standardized SDH defines infrastructure for modern multiplexer technology and provides good overall interoperability between different brands, though it provides support for earlier investments and legacy protocols as well. Integrated management features and fast protection schemes make SDH networks very reliable and resilient, which ensure high availability, fast and predictable transmission times, as well as quick reconfiguration in fault situations.

The advantage of SDH is the ability to autonomously transmit signals with strict timing constrains in parallel to bursty packet-switched Ethernet-traffic, which makes possible to integrate the utility companies' critical automation, protection and control operations with administrative data and audio/video services into a utility-wide communication network. Moreover, the high capacity that meets the utility's own needs can also provide data services for 3rd party customers.

The FOX515 has versatile interfaces for automation applications as well as for standard telecommunication services. However, the key factor in deployment of FOX515 is the teleprotection that provides very fast operating times for line protection in power networks. Furthermore, FOX515 supports Ethernet over SDH features with high QoS, which guarantees timely responses for the real-time SCADA and substation automation systems. FOX515 communications system utilization can reduce equipment and interface chains and the number of private or leased communication lines used to provide the different operational and administrative services, which can be seen as increased reliability, faster transmission times and more efficient operation and maintenance functions.

On the other hand, multiplexer equipment costs have not been able to keep up with the steady decline of native Ethernet hardware. In addition, SDH system design and network configuration can be more difficult and time consuming compared to the connectionless Ethernet-technology. Nevertheless, both technologies are continuing to evolve and are coming ever close to meeting the same performance goals. Furthermore,

it can be seen that SDH systems are for the most part to have long coexistence with Ethernet technology, while native Ethernet links are most likely to be deployed in brand new installations without significant presence of multiplexer equipment.

REFERENCES

- ABB (2000). *Teknisiä tietoja ja taulukoita (Technical Data and Tables)*. 9th Ed. Vaasa, ABB Oy. ISBN 951-99366-0-2. 626 p.
- ABB (2006). *FOX Family Overview* [online]. [cited 1 September 2008] Available from Internet: <URL:[http://abblibrary.abb.com/global/scot/scot221.nsf/veritydisplay/9e15df2ca2a5069dc1257091002968c2/\\$File/999_FOX%20Family.pdf](http://abblibrary.abb.com/global/scot/scot221.nsf/veritydisplay/9e15df2ca2a5069dc1257091002968c2/$File/999_FOX%20Family.pdf)>.
- ABB (2007). *FOX515 User Manual* [CD-ROM]. 4th Ed.
- ABB (2008a). *FOX515 Operation & Maintenance*. Unpublished. Baden: ABB University Switzerland. CHT592 course material.
- ABB (2008b). *Synchronous Transmission Systems (SDH)*. Ed. 5.2. 188 p.
- Ackerman, William J. (1999). Substation automation and EMS. *IEEE Transmission and Distribution Conference 1*, 274–279. ISBN: 0-7803-5515-6.
- Aggarwal, Raj & Philip Moore (1994). Digital communications for protection. Part II: Teleprotection systems. *Power Engineering Journal* 8:2, 97–102.
- Antonopoulos Andreas, J. J. O'Reilly & P. Lane (1997). A framework for the availability assessment of SDH transport networks. *Second IEEE Symposium on Computers and Communications*, 666–670. ISBN: 0-8186-78526.
- Belagur, Jai & Rick Schmidt (2008). IP communication for substation automation, distribution automation, and other utility applications – A business case. *Transmission and Distribution Conference and Exposition*, 1–9. ISBN: 978-1-4244-1903-6.

- Edwards, J.A. (1998). Protection interworking for SDH networks. *6th IEE Conference on Telecommunications*, 202–205. ISBN: 0-85296-700-4.
- Ericsson, Göran N. (2002). Classification of power systems communications needs and requirements: Experiences from case studies as Swedish national grid. *IEEE Transactions on Power Delivery* 17:2, 345–347.
- Ericsson, Göran N. (2004). Communications requirements – Basis for investment in a utility wide-area network. *IEEE Transactions on Power Delivery* 19:1, 92–95.
- Ericsson Telecom AB & Telia AB (1998). *Understanding Telecommunications 1*. Lund, Sweden: Studentlitteratur AB. 487 p. ISBN: 91-44-00212-2.
- Ferguson, S.P. (1994). Implications of SONET and SDH. *Electronics & Communication Engineering Journal* 6:3, 133–142.
- Goleniewski, Lillian (2001). *Telecommunications Essentials: the Complete Global Source for Communications Fundamentals, Data Networking and the Internet, and Next-Generation Networks*. Boston: Pearson Education Inc. 582 p. ISBN: 0-201-76032-0.
- Gupta, Ram Prakash (2008). Substation automation using IEC 61850 protocol. *Fifteenth National Power Systems Conference*, 642–644.
- Haji, Fardeen, Larry Lindsay & Shaowen Song (2005). Practical security strategy for SCADA automation systems and networks. *Canadian Conference on Electrical and Computer Engineering*, 172–178.
- Horak, Ray (2000). *Communication Systems and Networks, 2nd ed.* Foster City, California: IDG Books Worldwide, Inc. 697 p. ISBN: 0-7645-7522-0.

ITU-T Recommendation G.707/Y.1322 (2007). *Network Node Interface for the Synchronous Digital Hierarchy (SDH)*. 196 p.

ITU-T Recommendation G.811 (1997). *Timing characteristics of Primary reference Clocks*. 11 p.

ITU-T Recommendation G.841 (1998). *Types and Characteristics of SDH Network Protection Architectures*. 141 p.

Kirkman, Robert (2008). Developments in substation automation systems. *Third International Conference on Electric Utility Deregulation and Restructuring and Power Technologies*, 598–603. ISBN: 978-7-900714-13-8.

Leroux, André & Bruna Giguère (2007). *SONET/SDH vs. Ethernet: Migration and Testing Issues* [online]. [cited 29 June 2009] Available from Internet: <URL:<http://documents.exfo.com/appnotes/anote152-ang.pdf>>.

Mak, Kwok-Hong & Barry L. Holland (2002). Migrating electrical power network SCADA systems to TCP/IP and Ethernet networking. *Power Engineering Journal* 16:6, 305–311.

McClanahan, Robert H. (2003). SCADA and IP: Is network convergence really here? *IEEE Industry Applications Magazine* 9:2, 29–36.

Mraovic, Milan, Natasa Gospic & Vladimir Milosevic (2007). Management and monitoring of telecommunication system in electric power transmission company. *8th International Conference on Telecommunications in Modern Satellite, Cable and Broadcasting Services*, 613–616. ISBN: 978-1-4244-1467-3.

OpenCon Systems, Inc. (2003). *DCC Solutions for SONET/SDH Systems* [online]. [Cited 6 November 2008] Available from Internet: <URL:<http://www.opencon.com/dcc/DCC-white-paper-Rev2.pdf>>.

Pan, John W. (2008). *Loop Telecom Ethernet Order Wire* [online]. [Cited 12 January 2009] Available from Internet: <URL:http://www.looptelecom.com/WebSystem/FileSystem/white_paper/38EOW%20for%20O91S_O94S_O94R.pdf?PHPSESSID=709b9f1720ace90f6c29cc5fc31c0ed6>

Rados, Ivan, Tanja Sunaric & Pero Turalija (2002). Availability comparison of different protection mechanisms in SDG ring network. *Modern Problems of Radio Engineering, Telecommunications and Computer Science*, 287–290. ISBN: 966-553-234-0.

Renfors, Jori (2007). Engineering thesis: *Alueverkon laajentaminen TeliaSonera Finland Oyj:lle*. Tampere, Finland: Tampere Polytechnic. 52 p. Available only in Finnish.

Richards, S.H., S.C. Potts & C.J.L. Best (2004). Reliable and secure teleprotection schemes – direct implementation in main protection. *Eighth IEE International Conference on Developments in Power System protection 2*, 722–725. ISBN: 0-86341-385-4.

Sivarajan, Kumar N., Sarath Kumar & A. Jishnu (2006). Converge in optical transport networks. *Institution of Electronics and Telecommunication Engineers Technical Review* 23:4, 215–220. ISSN: 0256–4602.

Skendzic, Veselin & Roger Moore (2006). Extending the substation LAN beyond substation boundaries: Current capabilities and potential new protection applications of wide-area Ethernet. *Power Systems Conference and Exposition*, 641–649.

- Sklar, Bernard (2004). *Digital Communications: Fundamentals and Applications*, 2nd ed. Upper Saddle River, New Jersey, USA: Prentice-Hall, Inc. 1079p. ISBN: 0-13-084788-7.
- Uotila, Pekka (2001). *Tietoliikenteen tekniikka: verkot ja protokollat*. Helsinki, Finland: Gummerus Kirjapaino Oy. 238 p. Available only in Finnish. ISBN: 951-762-800-5.
- Usta, Ö., M. A. Redfern & M. Bayrak (1998). Data communications for power system relaying. 9th *Mediterranean Electrotechnical Conference* 2, 964–968. ISBN: 0-7803-3879-0.
- Weiss, Rene (2009). *Re: Questions on FOX515* [online]. Message to: Kimmo Levonen. Personal communication with the product manager of Power Systems, ABB Switzerland Ltd. 12 May 2009.
- Yahong, Wang & Wu Hequan (1998). Application of on-line test idea for avoidance of timing loop. *International Conference on Communication Technology Proceedings* 2, 1–5.