

**UNIVERSITY OF VAASA**

**FACULTY OF TECHNOLOGY**

**ELECTRICAL ENGINEERING**

Anna-Karin Back

**INVOLVEMENT OF SMART END-USERS IN A SMART GRID**

Master's thesis for the degree of Master of Science in Technology submitted for inspection,

Vaasa 20.5.2011

Supervisor

Kimmo Kauhaniemi

Evaluator

Timo Vekara

Instructors

Kari Koivuranta, Ville Karttunen

## TABLE OF CONTENT

TABLE OF CONTENT	II
SYMBOLS AND ABBREVIATIONS	IV
ABSTRACT	V
TIIVISTELMÄ	VI
1. INTRODUCTION	1
1.1. Background	2
1.2. CLEEN and the SGEM project	4
1.3. Fortum	5
1.4. Objectives and scope of the thesis	6
2. SMART TECHNOLOGY CONCEPT	9
2.1. Grid structure	11
2.2. Smart grid opportunities	12
2.2.1. Distributed generation	12
2.2.2. Energy storage	18
2.2.3. Electrical vehicles	19
2.2.4. Demand response	20
2.2.5. Aggregators	22
2.2.6. Price signals	24
2.2.7. Automated metering management	25
2.2.8. Micro grids and distributed energy resources	27
2.3. Smart house technology	28
2.3.1. Scientific management	29
2.3.2. Building Energy Management Systems	30
2.3.3. Smart home devices	33
2.3.4. User interfaces	35
3. CUSTOMER INTERCATION	36
3.1. Rogers model: Diffusion of innovations	37
3.1.1. The innovation	37
3.1.2. Communication channels	40
3.1.3. Time	41
3.1.4. Social system	43
3.2. Customer behavior	44
3.2.1. Telecommunication trends in Finland and Sweden	45
3.2.2. End-user segmentation	46
3.3. The society's perspective on electrical energy	48
3.3.1. Electricity consumption and feedback practices	50

4.	INVESTIGATION ON AREAS OF INTEREST TO THE CUSTOMER	52
4.1.	Investigation of customer interaction at Fortum	52
4.1.1.	Analyze of statistics for incoming phone calls to CIS	53
4.1.2.	Planning of interviews	56
4.2.	Customer interaction and service, Sweden	56
4.2.1.	Questions based on the statistics	57
4.2.2.	Questions regarding electricity usage and smart house technology	59
4.2.3.	Power quality complaints	62
4.3.	Customer interaction and service Finland	63
4.3.1.	Questions based on the statistics	63
4.3.2.	Questions regarding electricity usage and smart house technology	64
4.4.	Reflection over noticed similarities and deviations between the countries	66
4.5.	Reflections from the interviews	67
4.6.	Continuous gathering of information	68
5.	SMART HOUSE FUNCTIONALITY	70
5.1.	Interaction	72
5.1.1.	Exchange of power demand information	72
5.1.2.	Demand response	74
5.2.	Home automation	76
5.2.1.	Supportive device	77
5.3.	Service structure	79
5.4.	User interfaces	81
5.4.1.	Central display	82
5.4.2.	Mobile media units	83
5.4.3.	Communication of service information	83
5.4.4.	End-user awareness through knowledge	84
5.5.	Parallels to Rogers model of diffusion	85
5.6.	Communicating the smart grid offering	86
6.	CONCLUSIONS	89
	REFERENCES	92
	APPENDIXES	97
	Appendix 1: Base material for CIS interviews	97
	Appendix 2: Answers from CIS interviews Sweden	98
	Appendix 3: Answers from CIS interviews Finland	110

## SYMBOLS AND ABBREVIATIONS

BEV	Battery only Electrical Vehicle
DG	Distributed Generation
DGO	Distribution Grid Owner
DMS	Demand Management System
DR	Demand Response
DSO	Distribution System Operator
EMS	Energy Management System
ERGEG	European Regulators Group for Electricity and Gas
EV	Electrical Vehicle
GIS	Graphical Information System
HEV	Hybrid Electrical Vehicle
ICT	Information Communication Technology
LOM	Loss-of-mains
PHEV	Plug-in Hybrid Electrical Vehicle
SGEM	Smart Grids and Energy Market
TSO	Transmission System Operator
VPP	Virtual Power Plant

---

**UNIVERSITY OF VAASA****Faculty of technology**

<b>Author:</b>	Anna-Karin Back
<b>Topic of the Thesis:</b>	Involvement of smart end-users in a Smart Grid
<b>Supervisor:</b>	Professor Kimmo Kauhaniemi
<b>Evaluator:</b>	Professor Timo Vekara
<b>Instructor:</b>	Kari Koivuranta, Ville Karttunen
<b>Degree:</b>	Master of Science in Technology
<b>Department:</b>	Department of Electrical and Energy Engineering
<b>Major of Subject:</b>	Degree program in Electrical and Energy Engineering
<b>Year of Entering the University:</b>	2004
<b>Year of Completing the Thesis:</b>	2011

---

**Pages:** 96+14

**ABSTRACT**

To reach the 20-20-20 goals set by EU in 2009, all parts of the electricity system must be made more efficient. The previous fit-and-forget system must be left behind for a more active grid design. This also means that end-users must become an active part of the power grid. Consumers should be able to actively sell and buy their own energy and control their own usage of energy, or allow for a third party to handle this. A large part of the smart grid will be realized by using computer technology and telecommunication, which can send information to the different parts of the electricity grid. This makes it possible to make complex decisions, based on large quantities of collected data, concerning the most beneficial grid control decisions. This also enables energy efficiency throughout the entire electricity grid, all the way from production through transmission and distribution, including customer premises. This will help Finland reach the 2020 goals, but also achieve a function of the electricity grid that aligns with today's expectations and demand for functionality.

In this thesis the features that may arise from the development of a new smarter electricity grid has been investigated and how these functions align with the ordinary electricity consumers' interest and expectations on functionality. Demand response, distributed generation, energy storage systems, home automation systems and interactive user interfaces are some of the discussed features. The behavior of the end-users was researched through literature studies and by analyzing customer contacts at Fortum. The analysis showed two main reasons for contacting Fortum. Forced contacts, like customers moving, are matters that could be solved to some extent by interactive user-interfaces. The investigative contacts showed customer interest in electricity prices and agreements but also problems with understanding the electricity bill. In this thesis the Rogers' model for diffusion of innovations has also been described and used to analyze smart grid and smart house technology. The main result of the thesis is the definition of a collection of smart house functionalities that would serve as a good base for the development of added value services.

---

**KEYWORDS:** Smart grid, smart house, Rogers' model, customer behavior, customer interaction

---

**VAASAN YLIOPISTO****Teknillinen tiedekunta**

<b>Tekijä:</b>	Anna-Karin Back	
<b>Diplomityön nimi:</b>	Älykkäät kuluttajat osana älykästä sähköverkkoa	
<b>Valvoja:</b>	Professori Kimmo Kauhaniemi	
<b>Tarkastaja:</b>	Professori Timo Vekara	
<b>Ohjaaja:</b>	Kari Koivuranta, Ville Karttunen	
<b>Tutkinto:</b>	Diplomi- insinööri	
<b>Oppiaine:</b>	Sähkötekniikka	
<b>Opintojen aloitusvuosi:</b>	2004	
<b>Diplomityön valmistumisvuosi:</b>	2011	<b>Sivumäärä:</b> 96+14

---

**TIIVISTELMÄ**

Jotta voidaan päästä EU:n vuonna 2009 määrittämiin 20-20-20 tavoitteisiin, kaikkien sähköjärjestelmien kaikki osat on saatava tehokkaammaksi. Perinteinen ”asenna-ja-unohda”-käytäntö on jätettävä taakse kun aletaan suunnitella entistä aktiivisempaa jakeluverkkoa. Tämä tarkoittaa myös sitä että loppukäyttäjä tulee olla aktiivisempi osatekijä sähköjakeluverkossa. Kuluttajien pitäisi itse pystyä aktiivisesti myymään ja ostamaan energiaa ja myös kontrolloimaan energiakäyttöänsä tai sallia kolmannen osapuolen hoitamaan asiaa. Suuri osa älykkästä sähköverkosta toteutetaan tietotekniikalla ja tietoliikenteellä, joiden avulla tietoa voidaan välittää jakeluverkon eriin osiin. Tämä mahdollistaa monimutkaisen päätöksenteon jakeluverkon parhaimmasta mahdollisesta ohjaustavasta perustuen suureen määrään kerättyä tietoa. Tämä puolestaan mahdollistaa energiatehokkuutta läpi koko sähköverkon, aina tuotannosta sähkösiirtoon ja sähköjakeluun asti mukaan lukien asiakkaan sähkönkäyttö.

Tässä työssä on tutkittu toimintoja joita voidaan ottaa käyttöön uutta älykkäämpää sähköjakeluverkkoa kehitettäessä ja selvitetty erityisesti miten nämä toiminnot kiinnostavat tavallisia sähkökuluttajia ja sopivat heidän odotuksiinsa. Tarkasteltavia älykkään sähköverkon ominaisuuksia ovat mm. kysyntäjousto, hajautettu sähköntuotanto, energian varastointijärjestelmät, kodin automaatiojärjestelmät ja interaktiiviset käyttöliittymät. Loppukäyttäjien näkemyksiä tutkittiin kirjallisuuden perusteella ja analysoimalla asiakasyhteydenottoja Fortumilla. Analysointi kertoi että Fortumiin otettiin yhteyttä pääasiassa kahdesta syystä; pakolliset yhteydenotot (esim. muutot) ja erilaiset tiedustelut (esim. hintoihin liittyvät). Asiakasyhteydenottotutkimus kertoo asiakkaiden kiinnostuksesta sähköhintoihin ja sopimuksiin mutta myös sähkölaskun ymmärtämiseen liittyvistä ongelmista. Työssä on lisäksi kuvailtu Rogers’in malli innovaation diffuusiosta ja käytetty sitä älykkäiden jakeluverkkojen ja älykotien teknologian analysoinnissa. Työn keskeisimpänä lopputuloksena on määritelty kokoelma älykodin toiminnallisuuksia, jotka voisi toimia hyvänä perustana lisäarvopalveluiden pitkäaikaisessa kehittämisessä.

---

**AVAINSANAT:** Älykäs sähköverkko, älykoti, Rogers’in malli, asiakaskäyttäytyminen, asiakasvuorovaikutus

## 1. INTRODUCTION

The energy market is facing a radical change and there are many drivers pushing towards this change, environmental issues are one of them and a natural technological advancement is another. EU legislation approved by member countries necessitate for streamlining the entire electricity grid, all the way from production through transmission and distribution, including customers' in-house devices, to achieve established goals.

With this evolution comes the possibility of creating a wide range of new functionality and services towards electricity customers. One of the challenges in the procedure of developing an electricity grid that supports all the new technologies is the task of enabling the customers to become, and allowing them to be, an active part in the electricity market and within the area of grid functionalities.

The public consultation paper *Position paper on smart grids, an ERGEG Public consultation paper* written by the European regulators group for electricity and gas (ERGEG) states that:

*With this evolution, the power grid will become a platform for new energy services provided by new stakeholders and will be expected to offer added value for customers. Winning the hearts and minds of consumers will be vital to realizing all of the benefits that a smart grid will be able to offer. It is also likely to require changes in market structure, commercial arrangements and regulation. (ERGEG 2009:7)*

### 1.1. Background

Traditionally the electricity generation, distribution network management and loads have been considered as quite independent processes. Electricity has been generated in large centralized power plants which are regulated according to how much energy is consumed at the moment. If the pre-estimated amount of electricity produced proves not to be sufficient, additional power plants are started to cover the consumers need for energy. All of this happens outside of the regular consumer's knowledge and awareness. Most of the electricity consumers have no chance of knowing when there is a power shortage and cannot adjust their own power load accordingly. The feedback information given to electricity consumers about their consumption has been an electricity bill a few times per year for residential customers, whereas some of the bills were usually estimated and corrected by the next one.

The EU legislations approved by member countries are known as the 20-20-20 targets; a set of three key objectives in the European energy policy to be achieved by the year of 2020. The Climate-Energy Legislative Package with three key objectives states that green house gas emissions should be cut by at least 20 % with respect to 1990, a 20 % share of the total energy production should be covered by renewable energy sources and that energy consumption in the year of 2020 must be lowered by 20% with respect to the projected consumption by improved energy efficiency. These are the goals of the 20-20-20 targets and together they form a solid foundation for the future ambitious objectives to be set for year 2050. (ERGEG 2009:9)

This encourages research and development of alternative ways to produce more environmental friendly electricity. Power plants generating electricity by using zero- or low-emission production types are continuously developed and implemented, wind power parks, solar power and wave power being examples of zero-emission production. As environmental concerns are more and more raised in society and the price of energy, electricity, is expected to rise in the future. Consequently, the consumers' environmental and economical awareness will probably lead to an increase in implementation of small scale



energy sources. Placing power production on customer premises also means that, in the future, power production will be located in a decentralized way. This is also referred to as distributed generation (DG). Small scale and micro DG adds to the share of renewable power production.

Other technology inventions with association to the electricity grid, like electrical vehicles that are expected to contribute to lowering emissions, are also introduced in the society. However, these also challenge the construction of the distribution grid in their need for an effective power charge and possibly the need to keep track of who makes a power charge when and where. On the other hand electrical vehicles could be utilized as an active energy resource when used as energy storages. (Cleen 2009:5)

When this, and further technological innovations, becomes a common appearance in the society the electricity system should be advanced enough to integrate these features into a solid smart system which allows for all of parts of the system to function in an optimized way. This will, as pointed out by Brown (2008), be more beneficial than just summing up the features one by one. (Brown 2008) Further, the 20-20-20 goals should be fulfilled with an obtained, or preferably raised, level of security and functionality in the power grid, towards all of its users. To be able to achieve this ambitious goal all stakeholders of the energy chain must collaborate. The ERGEG position paper states:

*"While there is much attention focused on the development of zero and low-carbon electricity generation, there is a growing consensus that today's networks will not be able to effectively integrate this new generation into a coherent system including effective demand response."* (ERGEG 2009:9)

The environmental issue is not the only driver pushing towards a change in the way we think of and design the power system today. Other drivers towards updating the power system are the rising energy demand and the technology advancements made. Today's grid will probably not be able to support the estimated energy demand nor is it advanced enough to fully support today's technology. This means that the power grid we know to-

day is changing towards a more complex power grid referred to as Smart Grid. (Leeds D. 2009:17; ERGEG 2009)

## 1.2. CLEEN and the SGEM project

CLEEN Ltd, Cluster for Energy and environment, is a strategic centre for science, technology and innovation for energy and environment. The strategic research managed by CLEEN Ltd. is a common vision defined by its shareholders consisting of 28 major international companies and 16 national research institutes and universities. CLEEN Ltd. currently manages three ongoing research programs, Smart grids and Energy Markets (SGEM), Future Combustion Engine Power Plants (FCEP) and Measurement, Monitoring and Environmental Efficiency Assessment (MEEA).

Several major industrial companies operating in Finland, essential network companies and major research institutions and universities of the considered research domain jointly work for a common vision. Organizing in this way is a completely new way to do energy and environmental research in Finland. Focus is put on industrial research and this is expected to develop a world leading know-how. The research facilitates development of the innovation chain and the development of a globally competitive technology and service products. (Cleen 2010)

This thesis is part of the SGEM program which is a 5-year overall research program with a research plan based on strict descriptions of annual research task. The tasks forms separate work packages with measurable goals. The research program supports the goals of CLEEN Ltd. and the vision of smart grids presented by SGEM program takes this into account and lists needs of the smart grid being developed.

The SGEM projects vision for the smart grid is among other things that it should be interactive with customers and markets, adaptive and flexible using high level automation and control equipment to take secure and fast safety decisions, optimized to make the best use of resources and equipment and of course secure and reliable. Customers should be an active part that consume and produce, buy and sell electricity and control their electricity

use and/or permitting it to be controlled by an external actor. In order for that to become reality the electricity grid and the functionality around it must then be designed to enable these kinds of activities.

Five different research themes can be found within the research program with subtasks are listed below. The aim of the research themes is to study various Smart grid architectures and their applicability in different environments and conditions. Figure 1 describes research strategy of SGEM.

- 1) Smart Grid architectures
- 2) Future infrastructure of power distribution
- 3) Active Resources
- 4) Intelligent management and operation of smart grids
- 5) Energy market

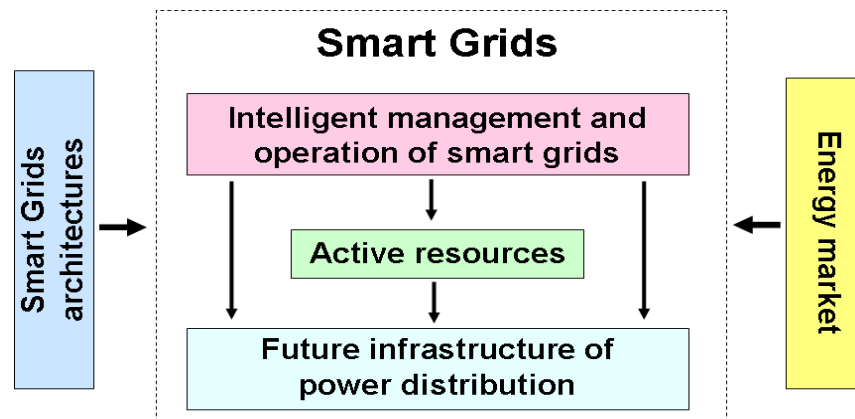

**Figure 1.** SGEM research strategy. (Cleen 2009)

### 1.3. Fortum

Fortum is divided into four divisions. Fortum Power consists of power production, planning and trading on the physical electricity market. Fortum Heat is responsible for heat production (CHP), district heating and cooling and heating solutions to companies. Fortum Russia consists of heat and power production and sales in Russia. Fortum Electricity

solutions and Distribution (ESD) is responsible for Fortums electricity sales and distribution which is divided into three business units, Distribution, Electricity sales and marketing and New Business.

ESD is one of the leading actors in the Nordic energy market. Distribution own and maintain regional and local electricity network for a total of 1.6 million customers in Finland, Sweden, Norway and Estonia. Electricity Sales and Marketing markets and sell electricity to 1.3 million private and business customers and other electricity retailers in Finland, Sweden and Norway. New Business develops and invests in future energy solutions like smart grids, smart homes, AMM, small scale power production and infrastructure for charging of EVs. That BU is an active part in smart grid projects like *'The Royal Seaport'* in Stockholm, *'The Adjutantti project'* in Espoo and recently introduced an energy display, called *'Min Solo'* to Fortums Swedish customers. The display shows real-time and historical consumption data and is to be used in addition to the electricity meter.

Fortum is one shareholder of Cleen Oy and within Fortum an internal workgroup for the SGEM project was created. The workgroup has gathered continuously to report status of ongoing SGEM projects and plan further activities.

#### 1.4. Objectives and scope of the thesis

This thesis is a contribution to WP 1.2 of the SGEM program and is based on the task description of that work package and the overall visions of CLEEN and the SGEM program. The visions of the SGEM program and the public consultation paper *"Position paper on smart grids, an ERGEG Public consultation paper"* written by ERGEG have been used as a guidelines throughout the work with this thesis. (ERGEG 2009)(Cleen 2009)

Interaction between the end-user and the different actors involved is considered essential in order to encourage end-users to become an active part in the electricity supply system and in the electricity market. Winning the end-users consensus is a relevant issue. Economical incentives are calculated and discussed in several researches. On the other hand, end-users are necessarily not purely motivated by economic considerations. Other areas

of interests like service, flexibility and the new functionality provided by use of technology based solutions could also be driving factors. However, the public is probably not able or not prone to precisely recognize the benefit of these innovations in advance.

This thesis investigates what the functionality smart grid and smart house technology being developed today can offer end-users of the future and distinguishes factors that support a sustainable development of functionality. Onwards in text smart house and smart grid technology will be referred to as smart technology. According to Statistics Finland, households and agriculture stood for 25 % and service and the public sector stand for 19% of the total electricity consumption in Finland by the year of 2007. (Statistics Finland 2008) Thereby it can be concluded that domestic and small commercial customers represent a rather large part of the total electricity consumption in Finland and are relevant targets for investigation and optimization. These groups are also the least active today and thereby they will be the groups of focus of this work. (Cleen 2009)

Functionality opportunities arising from smart technology will be reviewed from the customers' point of view towards the electricity grid and market. This is done in order to reflect over what difficulties and opportunities end-users face. To do this, it has to be considered what and who is part of this system. What does all of this technology mean to its users and who are the users? How these smart technology opportunities affect the electricity grid will briefly be mentioned since that also, directly or indirectly, affects the end-users.

How end-users behave and what their interest are will be investigated through literature studies on customer behavior, general studies on electricity customers, development in usage of telecommunication, what people know about energy and energy consumption and what they relate to. Rogers' model for diffusion of innovations explains what an innovation is and how they spread and are accepted in societies. Since this smart technology will result in new innovations introduced Roger' model will be used to analyze how the public could react to smart technology and what should be considered when modeling the offering of smart technology in order to reach a better level of acceptance in society. (Rogers 2003)

To find areas of interest to the customers around smart technology opportunities and eventually find problem areas that could be solved by using smart technology incoming phone contact to Fortum will be studied.

As a result of the research done and the interviews with the customer service departments a collection of smart house and smart grid functionality that agrees with the recognized problem areas and interest of customers and the study on customer behavior is presented in Chapter 5. Further parallels are drawn between Rogers' model and the smart technology, which are also presented in Chapter 5. This could be used when modeling the offering of smart technology to end-users.

## 2. SMART TECHNOLOGY CONCEPT

The position paper on Smart Grids by ERGEG mainly describes smart grids as a way to optimize integration of new technology, required in order to achieve the European energy policy targets. Their perspective is technology neutral and they state that technology should be the means of an end and not the end itself. (ERGEG 2009)

Member countries of the EU must all review their own systems and find own ways to change their systems in the most beneficial way. This does not concern only the electricity grid, but also all devices connected to it. ERGEG mentions that renewal of the electricity grid is happening all over and without integration of these innovations the renewal process will result in a like-for-like replacement with loss of efficiency gain; *"A lack of 'smartness' in future electricity grids may either cause costs to raise or put constraints on the development of a low-carbon system"*. Consequently, one significant area of development in this process is the interaction between energy consumers and/or producers and the electricity grid. (Ibid:10)

Currently technology enabling for customers to become active is slowly being introduced. Some of these will be discussed as smart grid opportunities in this thesis; small-scale energy production, load management systems and different kind of energy storage systems, where electrical cars could serve as one possibility. A proper integration of these active, distributed energy resources (DER) will benefit the electricity grid if it can be managed appropriately. Flexible loads at end-users premises, allowing for different appliances to be controlled e.g. according to the current amount of energy available, could contribute to grid optimization. Controlling the end-users flexible loads e.g. according to energy access or electricity price is referred to as demand response (DR). DR can also be thought of as a virtual power plant (VPP) as peak power situations can be dealt with by controlling flexible loads, instead of starting less environmental friendly reserve power. In this thesis the end-user loads will be included in the term DER, as they can be utilized as a resource in dealing with different problem situations in the electricity grid. This can be part of DR and demand side management (DMS) functionality.

The SGEM program suggests development of interactive user interfaces to support DER functionality and active end-users. Managing end-user DER and providing different kinds of functionality to end-users is in this thesis referred to as smart house technology and functionality. Large-scale integration of intermittent energy sources in the electricity grid provides for efficiency in terms of lower transmission losses. However, with a fully stochastic consumption it also adds to a lowered controllability of power production. Through development of an interaction between smart houses and smart grids the controllability lost in production can be gained in partly controlled consumption by use of communication systems. This is described below in Figure 2. (EEIG 2009)

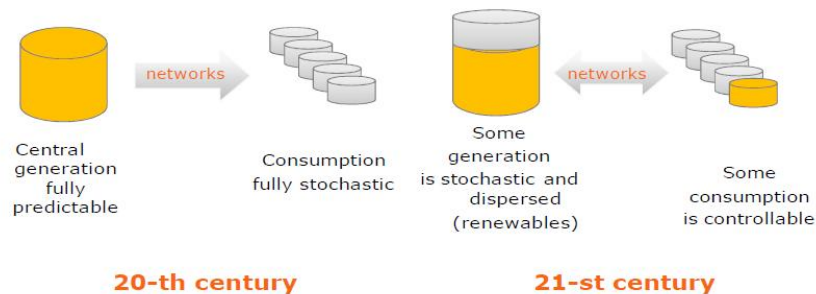

**Figure 2.** The power production and consumption ideology change. (EEIG 2009)

Electricity companies have for a long time had own separate local area networks (LAN) and wide area networks (WAN). These networks have been used to transport information within the electricity company's areas and to and from the substations. This is mostly concerning transmission and distribution lines, while there has been no interaction with the consumer premises. Taking the communication system all the way into the consumers' homes and even connecting their devices to this system will enable the consumer to be an active part of the electricity grid, when data can be sent to and from the consumer. The first step towards that scenario has already been done by installing automatic meter management (AMM). The network infrastructure sending data signals with meter readings from the end-user could also be used to send other kind of information or signals, in both directions. (Leeds 2009: 10; 15)



## 2.1. Grid structure

Traditionally power is generated by a relatively small amount of large power plants, located at remote sites usually close to supply routes and far away from end-users. The energy is transported from these remote sites to the scattered end-users by a hierarchical structure of high-voltage (HV) transmission networks, medium-voltage (MV) networks and low-voltage (LV) distribution networks. The electricity grid has been designed in a quite inelastic way and the distribution network is a passive system with only loads and no generation connected to it. Figure 3 shows the structure of the traditional hierarchical electricity grid. (Papaefthymiou et al. 2008)

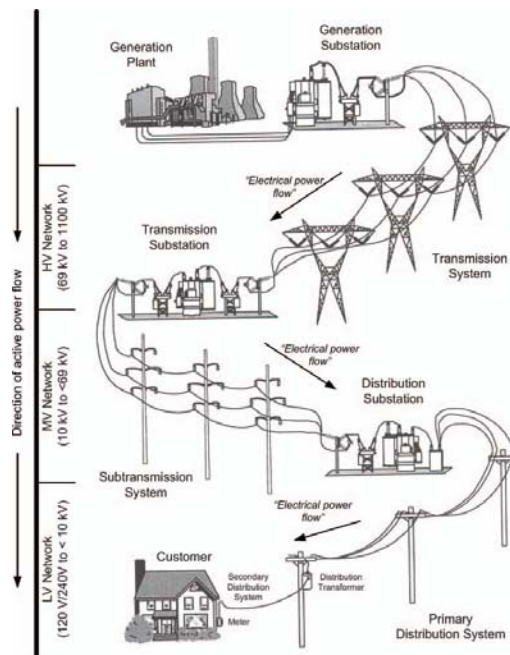

**Figure 3.** The figure displays a traditional, vertical transmission and distribution system with a hierarchical fuse system. This type of power grid is built for a one way power flow. (Ibid)

Power production in a vertical power system structure is mainly based on controllable primary energy sources, which permits for a robust control of the power generation system and therefore a reliable system operation. When DG becomes a common appearance, the grid model will change. Less controllable and predictable power being fed into the

lower voltage levels of the system leads to a radical change. Energy is no longer fed only vertically from higher to lower voltage levels but also horizontally from one point in the distribution network to another. What appears is a distributed grid model with energy production located in a distributed way. (Ibid)

The new structure of the power grid supports two-directional power and information flow. According to the ERGEG position paper, the main difference between the existing grid and the future smart electricity grid is "*the grid's capability to handle more complexity than today in an efficient and effective way*". Even though, there will be no substantial change in the physical 'architecture' of electricity networks. There will be a paradigm shift in the way electricity networks will be planned, operated and maintained in the future. (ERGEG 2009; Leeds 2009)

## 2.2. Smart grid opportunities

With the development and implementation of new technology and regulation, new functionality will be available to the end-users connected to the electricity supply system. These following paragraphs will describe some functionality and technology of the future system, advantages to end-users and grid owners and what barriers of today prevents the development. In the end of this chapter it is described how these functionalities can work together and support each other.

### 2.2.1. Distributed generation

There are many definitions to what DG is mentioned in literature. Generation could be connected to the power grid at any point suitable, by both utility and nonutility generators, large or small scale and the generation would still be distributed. However, it is commonly agreed upon that DG is any type of power generation integrated into the distribution network, or on the end-user side of the electricity meter. Several sources include some kind of energy storage in DG. In this thesis the technologies are handled separately. (Puttgen et al. 2003; Papaefthymiou G. et al 2008; Driesen and Belmans 2006)

Renewable energy can be defined as energy derived from a natural resource which replenishes itself over a short period of time. Renewable energy resources can produce both heat and electricity. Sun, wind, hydropower, organic plant and waste material (biomass) and earth heat (geothermal) are examples of common generation types (Science online 2010). When taking the chance of generating power from renewable energy sources generation will take place in an increasing amount of places. To get the most out of renewable energy sources generation is mainly placed at locations where energy can be extracted in large quantities and regularly. These places tend to exist at locations away from closely populated areas and energy is transported for long distances requiring a sufficient and efficient energy transfer. Renewable energy may also be found and utilized in smaller quantities close to the end-users and even at end-users premises, making end-users both consumers and producers.

Renewable energy is one part of DG, but not all of it. End-users could connect just about any type of generation technology available, renewable or nonrenewable, as long as it full fills the requirements set by the grid-owner. Examples of non renewable energy sources are internal combustion engines, combustion turbine, micro turbines and fuel cells. Some nonrenewable energy generation is a fairly low-cost investment and it could be used rarely at super-peaking power situations to relieve stress on the grid. But implementing too much nonrenewable energy resources in the power grid contributes to air pollution instead of lowering it. (Puttgen et al. 2003)

DG units are also categorized according to level of controllability. Conventional, centralized generation is considered to be fully controllable; an operator can regulate the power output of the energy source by regulating inflow of the primary energy source. In the case of using small scale DG most of them are not that easily controlled, depending on type of primary energy source. Generation units with a built-in, internal control and possibility for limited external control are referred to as partially-controllable. Others have an internal control system that does not allow external operation and are referred to as stringently-controlled. A fourth type is the fully stochastic DG unit, driven by a primary energy source that cannot be controlled at all. Examples of this type are small hydro and wind turbines, photovoltaic's, tidal and wave power plants. (Papaefthymiou G. et al. 2008)

Fortum Distribution in Sweden has started implementing small scale DG, into their electricity grid. The most common DG types are solar power, wind power and small-scale biogas. Bo Alfredsson at CIGS, Fortum, confirmed in April 2010 that end-users announce implementation of new DG units in Fortums electricity grid regularly. More connected DG units are expected over time, as regulation and the implementation system are figured out. Being able of giving complete specifications on what is demanded from the end-user in order for Fortum to accept the DG units in the electricity grid is essential; having standards referring to what is demanded in concern of power quality of in-feed power from the converters and requirements set on protection. (Alfredsson 2010)

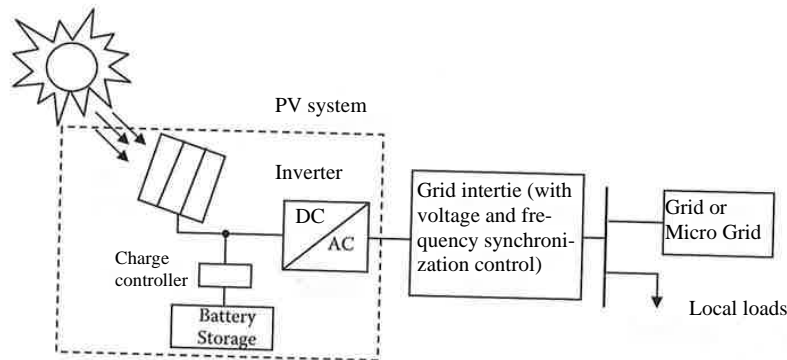

**Figure 4.** This is a schematic drawing of a PV system that shows the basic functionality. (Momoh 2008)

Due to the fact that solar and wind power are two commonly known ways for residential customers to produce energy these types will be briefly presented. Solar energy can be utilized by using photovoltaic (PV) cells basically constructed from a material that produces an electric current when exposed to light. PV modules provide no emissions and are a reliable, low maintenance, type of generation. However, it is traditionally not recommended as the main electricity supply since the primary energy source is sunlight and thereby the power output is uncontrollable. The term insolation level is used to describe the amount of solar energy available for conversion to electricity and is affected by the operating temperature, the intensity of light and the position of the PV unit. PV units are often mounted on roof tops which maximizes perpendicular incident light due to a fortunate angle towards the sun. There is also sun following stands available in the market.

The PV cells produce DC electricity which is converted to AC electricity by an inverter, placed between the PV unit and the electricity grid. Figure 4 displays a scheme of a PV system. (Momoh 2008)



**Figure 5.** A vertical wind mill is shown to the left and the areofortis model to the right. (Egenel 2010)

Wind turbine systems have been used for many years to convert wind energy into electrical energy and are one of the fastest growing sources of energy today. Wind turbines convert energy from the wind into electrical energy without producing emission. The system basically includes a rotor, generator, turbine blades and driver or coupling device. The rotor can be of vertical or horizontal type and the power output is dependent of the wind speed, the characteristics of the blade and the height of the pole it is mounted on. How the wind turbine system is located is important in sizing the output of the windmill. The output power of a windmill is not controllable which makes it challenging to use as a primary or sole electricity source. (Momoh 2008)

A commonly known model of windmills is the horizontal model with three blades. Since the height of the stand which the wind mill is mounted on and the location of the wind mill is important in optimizing the output, windmills have been best suited for usage in rural areas. Today vertical models are available on the market, with stands for mounting on roof-tops. This makes installation of windmills appropriate for city buildings. Another newcomer is the areofortis model which has a ring around the rotor blades that lowers noise problems. A vertical model is shown in Figure 5 together with the areofortis. (Egenel 2010)

Producing electricity near by the load points is efficient in terms of avoiding transmission losses and transmission system losses. Losses in the power supply system appear in generation, transmission and distribution. Power system losses consist of electrical losses due to energy loss in windings; copper and iron losses, thermal losses due to apparatus exceeding their thermal ratings, mechanical losses due to vibrations and human error in measurements. (Momoh 2008)

DG is modular enough to be conventionally integrated within the distribution network, there by relieving some of the necessity to invest in transmission system expansions. However, significant DG penetration also brings a new set of problems forward. Different kinds of DG technologies affect the grid in different ways. The Finnish special interest organization Finnish Energy Industries (Energiateollisuus ry.) has put together a recommendation "*Connecting micro-generation to the distribution grid*" which helps grid owners when setting requirements for connecting DG to the distribution grid as it looks today. (Energiateollisuus)

The first, most obvious thing is the issue of safety. With today's technology DG may not maintain network voltage during loss-of-mains (LOM) situations. There must be a built in protection system preventing the DG unit from feeding electricity into a zero voltage network. This is, among other things, a matter of safety in maintenance and repair situations. Grid service personnel must be confident that the grid is isolated once disconnected.

Integration of DG units does not go well with the hierarchal manner of protection systems in electricity grids with automatic reclosing, and fuses within the distribution grid that trips on a given maximum current and expects a one way power flow. In case of a fault occurring in the electricity grid the overall fault-current close to the fault could rise if there is a considerable amount of DG connected to that area of the grid. This since short-circuit currents can be fed into the network by the DG units. If the DG unit is connected to the grid through a converter, the internal properties of the converter limits the amount of current that can be provided by the DG unit. However, a DG unit driven by an asynchronous generator can for a short duration feed large amounts of short-circuit currents to

the grid. Two malfunctions in network protection are false tripping and blinding of the protection. Further about this can be read in the articles "*Analysis of the impact of distributed generation on automatic reclosing*" and "*Impact of distributed generation on the protection of distribution networks*" by Kauhaniemi K., and Kumpulainen L.. (Kauhaniemi K. and Kumpulainen L 2004 a; Kauhaniemi K. and Kumpulainen L 2004 b)

DG affects voltage quality in several ways. Among other things DG can help with voltage support. Voltage drops occur at high power load, if the grid is not strong enough to feed sufficient power. DG units serve as an additional power support and consequently, lowering the end-users total power load drawn from the grid. However, with a radial design of distribution grids, built with a certain voltage drop in mind, a large implementation of DG can lead to problems with high voltage levels. When introducing DG units of stochastic type to the grid, the load relief from these units is very unpredictable causing voltage levels to fluctuate. (Driesen and Belmans 2006)

Several of the DG technologies rely on some kind of power electronic device in conjunction with the distribution network interface, e.g. ac-to-ac or dc-to-ac converters. Converters produce currents that are not perfectly sinusoidal. The resulting harmonic distortion, if not properly contained and filtered, can bring serious operational difficulties to the other load points connected to the same distribution system. (Puttgen et al. 2003)

When looking at DG from the end-users aspect, DG could have many benefits. The end-user can lower their net energy consumption by also producing power and could even be able to make a profit from selling electricity, depending on the size of the installed DG unit and regulations. DG could keep the end-user supplied with power during power outages and help end-users to high enough voltage level, depending on connection configurations. However, regulations of today put some restraints on this due current regulation models and the structure of the electricity grid. By Swedish law (Ellagen 1997:857) grid owners are entitled to allow small-scale electricity producers to connect DG units and feed electricity to the grid as long as the production unit fulfills certain demands on safety and quality of the produced power. The production unit must have a mechanism that detaches the DG unit in case of a LOM situation, preventing the end-user from supplying

the local grid area. Grid owners are not forced to buy the electricity. Thus, since the in-fed electricity covers net losses the grid owner is entitled of compensating this to the end-user. According to the Swedish energy market inspectorate this has usually been compensated for by a lowered grid fee. (Sundberg et al. 2010:11)

The fact that the production unit will be disconnected in case of a disruption of electricity delivery is one reason to why end-users give up their plans on investing in DG; they expected to be self sufficient during electricity outages and even allowed to provide electricity for neighbors. Another reason is that they expect to earn equally big profit from feeding electricity back to the grid as their cost price. (Alfredsson 2010) This has not been the case since the price end-users pay for electricity consists of the electricity retail price, taxes, the transmission tariff plus a yearly transmission fee, while the compensation for feeding in electricity is a reduction in the transmission fee. With this regulation it is more beneficial for the end-user to control consumption according to their produced electricity than feeding it to the grid. The Swedish energy market inspectorate suggests a net pricing model for end-users with a main fuse of maximum 63A, who mainly consume electricity. When employing the net pricing model the amount of consumed electricity would be reduced with the amount of produced electricity which would be much more beneficial to the end-user. (Sundberg et al. 2010:24)

### 2.2.2. Energy storage

Energy storage is increasingly perceived as a both viable and necessary smart grid component, a backup system to DG. Storages provide the possibility of storing excess energy - generated at low power load - that would go unused if the DG unit was disconnected in order to maintain grid stability. This would capture energy that otherwise would be lost. The storage can be used as backup at sudden loss of a primary energy source like wind or sunlight. It would also smooth the typical variations in electricity generated by an intermittent energy source. Storages could also help to solve power quality problems by providing reactive power, voltage control and fault current limitations. Presently there is no single ideal storage technology. (Evens et al. 2010; Leeds 2009)



Energy can be stored in the form of electricity, mechanical energy or thermal energy. Characteristics like storage scale and speed differ between the different types. According to Leeds (2010) the leading technologies of 2009 were pumped storages (both hydro and compressed air), flywheels, sodium-sulfur batteries, super capacitors and flow batteries. Super capacitors and flywheels can provide fast power response which is needed for distribution line stability and power quality. Flow batteries can fulfill variable power demand and batteries, flywheel and capacitors are suitable for peak shaving and mobile power applications. (Leeds 2009)

Since electricity storages still are very expensive, it is still more beneficial to store energy in other shapes. GTM also says that compressed air is the most beneficial solution. However, that solution is limited by geographical condition. (Evens et al. 2010; Leeds 2009)

Further about research about energy storages has been conducted within Fortums SGEM group; this can be read in the report *Use of electricity storages in smart grids* by Sinikka Jussila within the Fortum SGEM group. (Jussila 2010)

### 2.2.3. Electrical vehicles

Electrical vehicles (EVs) are considered as one energy storage possibility and there are continuous studies going on regarding which battery type would be the most beneficial. EVs can be considered to be a mobile energy storage unit allowing for both the possibility of storing electricity and feeding electricity to the grid. In this thesis EVs are included in DER as a mobile electricity storage system. (Evens et al. 2010; Leeds et al. 2009)

Electrical vehicles can be of different types; hybrid electrical vehicles (HEVs), battery only electrical vehicles (BEVs) and plug-in hybrid electrical vehicles (PHEVs) which is a combination of the two. Figure 6 shows a schematic picture of a PHEV. Towards the electricity grid there challenges with the introduction of EVs; the grid must be able of handling large amounts of new, large appliances connected to the grid and there must be a way of utilizing all of these storage units in a beneficial way. There are ongoing studies on how and when to charge the EVs and some type of energy management systems is

considered necessary. Within the Fortum SGEM group Saara Peltonen has conducted further research on EVs; Impacts of large-scale penetration of EVs in Espoo area.

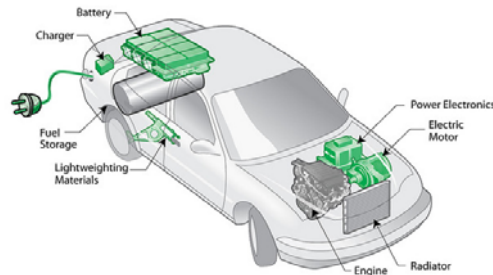

**Figure 6.** The figure shows a schematic picture of a PHEV, with the electric features enlightened in green.

#### 2.2.4. Demand response

DR is a known method for lowering power load on the grid at times of high demand for electricity. This has been realized in different ways during the years, from just making a phone call to customers with usual high electricity consumption to double tariff electricity meters. However, the DR planned and tested today is much faster and more flexible than that. When realizing the Smart grid and adding a communication network to the electricity grid several kinds of information can be sent much faster to and from the end-user. Smart grid provides a platform for more sophisticated methods where requests with information can be sent to and displayed to the end-user in numerous ways. Information can also be sent back from the end-user, manually or automatically, with acknowledgement from an automated system, informing if the DR action was or will be performed or not. This provides for high reliability to both end-users and grid owners.

Smart Grid 2010 describes demand response like this:

*"Contracts, made in advance, specifically determine both how and when the utility (or an acting third party intermediary) can reduce an end user's load. The utility benefits by not having to resort to more expensive (and less environmentally friendly) peaking power*

*plants, and customers benefit by earning income - making demand response a win-win solution."* (Leeds 2009:15)

Power load in the grid varies during the day and according to season. In the Nordic countries there is a higher need for space heating during the winter months which increases energy demand. This could be compared to the usage of air-conditioners in countries with a warmer climate. During a normal working day there are a normal peaking period at noon and one in the evening. These periods are considered to be the worst case scenarios, with highest peaking load and kept in mind by network planners when new network is planned. By adjusting some of the end-users energy consumption to times with lower energy demand, these peaks could be lowered and some strain on the electricity grid would be lead off. Consequently, use of expensive and less environmental friendly back-up power generation would be lowered and expansion of new transmission networks could be postponed for some time.

To be able to realize this function end-users must adopt this idea. Based on definitions of demand response given in literature the authors of the article "*Measuring the value of demand response using historical market data*", finds two reasons for demand response; electricity price and rationing. End-users who change their normal consumption pattern in response to changes in electricity price, due to high wholesale market prices or when system reliability is jeopardized. Both situations caused by high electricity demand. The power of ideology and willingness to help the society out should not be underestimated. (Abrate and Benintendi 2009).

There are also demand response programs going on where end-users enroll with or without economic incentives. These programs are closer to rationing and the incentives to the end-user can be of ideological character, helping the society, or economical. These programs are somewhat intended to increase the system operators' confidence that demand reductions will materialize when needed. This could mean that the end-users loads can be directly controlled by the utility company, or system operator, during certain critical times. The end-user can be offered compensation for enrolling in programs where the

system operator can curtail his load on short term notice to address reliability contingencies. (Abrate and Benintendi 2009)

There are several different types of loads connected at end-user premises making use of electric energy in different ways. Some loads use the energy at once while other stores the electrical energy into some other form of energy, which is used later in time. This affects their capability for being shifted in time. Evens et al. (2010) describe different types of end-user loads. (Evens et al. 2010)

Shiftable loads are loads that can be consumed at any point in time. Their total consumption of energy is independent of the time of use, but they must be run for a complete cycle to achieve their function. One example of this is a washing machine. These loads have a good flexibility which can be taken advantage of by planning their activity at times of low energy demand. Curtailable loads are the kind of loads that once switched off the energy that would have been used is saved. These loads can be started later, at any point of time and start at the same position as when they were shut down. Lights can be considered to be curtailable loads but also different pumping systems.

Evens et al. (2010) also describe different control actions for appliances of different characteristics (Evens et al. 2010):

- Start/Stop load completely with or without rescheduling to another time
- Modifying the consumption pattern of loads to achieve higher energy efficiency
- Interruption of an appliance at an intermediate stage where the cycle can be continued at a later point in time
- Interruption of devices in stand-by mode
- Optimized settings of comfort control devices of appliances in a way that lowers consumption but still achieves desired comfort level

#### 2.2.5. Aggregators

DR functionality can be realized without involving the utility's smart meter at all. The grid owners' responsibility and rights ends at the connection point at end-user premises.

The end-user is free to connect whatever kinds of meters or appliances after the electricity meter, as long as it does not interfere with the grid owners regulations on power quality. In theory third party companies could establish contracts with end-users to regulate their appliances and loads to steer them off peaking demand periods. This can be executed with or without economical incentives.

These types of companies are called aggregators since they aggregate groups of customers and form virtual power plants (VPP). In peak power situations lowering end-users power demand has the same impact as an increase in generation. The aggregator sells the decrease in end-user power demand to the grid owner the same way a retailer would sell generated power. Aggregators with a large amount of clients in his portfolio would be more reliable to grid owners since fewer end-users would have to respond to his requests to achieve desired load relief, or the time for curtailing end-users loads could be shorter. A larger number of smaller aggregators would mean that the aggregators would have to involve the end-users more, leading to a higher total use of DR. DR projects and aggregator functionality often involve some kind of energy efficiency incentive since the most environmental friendly energy still is the one never used and lowering total energy consumption is also an energy measure to the end-user.

Abrate and Benintendi (2009) explain the aggregator as an entity that manages the energy consumption for a set of clients. The aggregator can sell electricity to the end-user, but also use the resources of the same end-user. The end-user can sell the capability to modify their consumption and their generated electricity to the aggregator. (Abrate and Benintendi 2009)

The aggregator again sells the reduction in demand or the additional electricity to cover his obligations towards his clients or as a part of his trading activities. The end-users themselves would not be able to participate as their size would be too small or they would lack the knowledge to participate directly in trading with electricity. The relationship between the end-user and the aggregator can include all of the possibilities previously explained, from an exchange of information signals to the consumption and generation at the end-user side plus perhaps other additional services. (Ibid)

### 2.2.6. Price signals

*"Time-varying retail prices provide a direct incentive to a rational use of electricity for the consumer, who can decide to modify his consumption patterns on the basis of his own economic valuations. The extent of this change will depend on the consumers' price elasticity."* (Abrate and Benintendi 2009)

There are several ways of encouraging the end-users to move their normal consumption away from hours with high power load in the power grid. From years back this has been done by changing tariffs. Jessica Strömbäck at VaasaETT, the global energy think tank, conducted a research on 80 different demand response projects and how they manage to lower consumption at given time periods. Even though this is not the main target of her research, she also presents different dynamic pricing systems used and they are presented below. (Strömbäck et al. 2010)

Time of usage (TOU) pricing is a way of encouraging end-users to use more electricity during times of lower power load in the grid. During daytime and evenings there are two load peaks in residential consumption. Regularly TOU consist of two or three different tariffs per day; day, night and peak hour tariff. Figure 7 shows a TOU system used by an Italian regulator. This system uses three different tariffs. The high peaking tariff is rather long period of 9 hours. (Strömbäck et al. 2010)

In Finland and Sweden a type of TOU has been available for an extended time period and is still available. The system, called night and day tariff, uses two different tariffs during the 24-hour period. At end-user premises the method is realized with a double-counter electricity meter. However, the TOU system is losing supporters and is not actively advertised by utility companies anymore. A system that is a little more flexible could be more appealing to end-users.

Strömbäck et al. further mentions other dynamic pricing systems. When using spot pricing the end-user pays according to the whole sale market price. Strömbäck et al. points out that this will not lead to reduction in consumption without feedback. In order to encourage reduction the customer should be notified about high prices in some way or an

automation system with possibility to handle a price signal should be installed. Another side of this is also that an AMM meter giving hourly measurements is needed to calculate a bill that is dependent on the end-users actual consumption. In spot pricing systems the bill is often based on the end-users monthly consumption and adjusted according to normalized consumption patterns known as Betty-curves. When this is employed the end-user is not encouraged at all to change their behavior according to high peaking times. (Strömbäck et al. 2010)

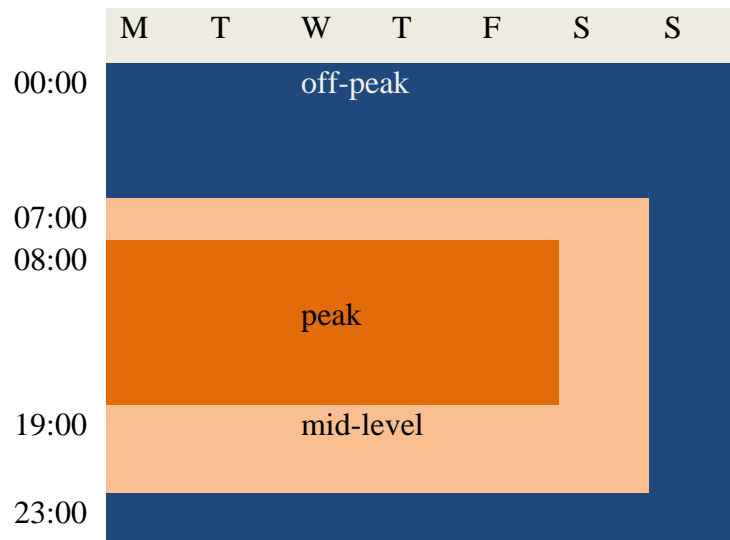

**Figure 7.** This figure shows the functionality of the TOU price model and origin from a TOU system, used by an Italian regulator. Inspired by Strömbäck et al.(2010) pilot comparison. (Strömbäck et al. 2010)

### 2.2.7. Automated metering management

All around the globe millions of conventional mechanical electricity meters are replaced by new advanced, network connected meters called "smart meters". These meters are part of an AMM system which consists of not only the meter but also a data transfer system and can be connected to different software applications. The software applications can analyze data collected by the smart meter and make use of it in several different ways.

The usual first step is using the meter for billing systems and for remote connection/disconnection of load points. When reading the electricity meter automatically end-users can receive a monthly bill based on actual electricity consumption and estimated

bills will become history. One of the basic ideas of this is to make the end-users more aware of their consumption, patterns and habits, and thereby use their electrical appliances in a more efficient way. This is also a way to make the grid owners work easier when no personnel has to be sent out for meter readings. The supplier-switching process and end-users moving in and out of houses is also simplified when meter readings can be retrieved automatically. It is also hoped for that the AMM meter would be a first step towards active demand response. (ERGEG 2009; Leeds 2009)

However, the AMM system can provide for much more functionality than that. By just installing automatically read electricity meters does not make the electricity grid smart. But the information they gather can be utilized in a smart way. Depending on the type of data collected by the meter and the time interval of measuring provide various possibilities for using the data for further analyses are provided. The ERGEG position paper explains that:

*"Smart metering systems allow internal metering for both active and reactive components of electricity consumed and injected to the network, so contributing to more accurate balancing losses and power factor calculation, to promoting peak and off-peak prices and discouraging bad practices in the use of the network. Smart metering technologies may further provide information on quality of electricity supply at each connection point, thus contributing to more effective investments and renovation plans of the grids, thereby increasing security of supply."* (ERGEG 2009)

If the functionality of AMM technology is fully exploited it can be of great value to both planning new grid structure and to end-users. AMM technology can among other thing be utilized together with outage management systems and for collecting actual data about end-users usage of electricity and be of great value for developing new grid structure and new services to end-users.(Ibid:15)

Further investigation in this area is done by Marko Meriläinen in his Master's Thesis "The Effective Exploitation of AMM Technologies in Smart Grid's Network Operation" within the Fortum SEGM group.



### 2.2.8. Micro grids and distributed energy resources

As has been handled in the previous sections of this chapter the electricity grid will have to deal with a larger quantity of stochastic DG in the future, which can be somewhat difficult to implement in the distribution grid. On the other hand, the load control that DR provides makes previously stochastic end-user loads more controllable. When using some kind of electricity storage together with DG, customers can store their energy in surplus situations and times of low electricity price. Using these technologies together makes the stochastic situation of DG usage more controllable and as mentioned in the introduction part of this work, optimizing the technologies to work together is said to give an overall effective solution.



**Figure 8.** Generation, electricity storage systems, flexible loads and EVs create DER. Customer premises to the left of the connection point and the electricity grid to the right. Picture composed by the author.

DG, energy storages, EVs, controllable loads are referred to as DER; the end-user has a set of technology which can include generation, storage and control systems (Figure 8). Then the end-user load is no longer passive. DER is an active system that can take energy from the power grid, feed energy to the grid and control loads according to availability of electricity in the grid.

Surplus situations caused by DG in one part of a distribution network could be made use of by end-users in other parts of the distribution network with power shortage. This forms

a distribution grid that would profit from disposing the energy inside and could be self sufficient at times and could handle an islanding situation without end-users having to lose supply. Distribution grids or parts of distribution grids could, when necessary, form smaller separate grids, called micro grids, which could make use of and control the energy produced inside them.

EMS again is a dispatching automation system mainly constructed for generation and transmission systems, which could be used for handling information within micro grids. An EMS system consists of a SCADA system and power advanced software's and provides real-time information for the grid operator. It also makes network operation and control decisions based on information collected from the grid. The EMS system can improve safety and power quality and assist in making economical decisions when operating the grid. (Yingyuan and Meiqin 2008)

These systems, both for managing end-user systems and systems dealing with the power grid leave a lot of space for software developers. Systems could make use of all types of in-put parameters like weather forecasts, price of electricity, power quality requirements and demand side management requirements to calculate control decisions which are energy and economically beneficial. (Yingyuan and Meiqin 2008) Systems for controlling DER should propose a strategy for how available DER should be operated so that services with different values to the end-user are provided while the cost of provision is minimized. (Pedrasa 2009)

### 2.3. Smart house technology

The first step towards energy efficiency would be to control appliances to be in use only as long as necessary and in the most effective way. Unused energy is naturally the cheapest and most nature friendly alternative of all. However, when that is done there is still room for further improvements. When striving towards energy efficiency, things like optimizing use by choosing correctly sized appliances and appliances with a high energy efficient coefficient are mentioned.

Smart house technology concerns energy efficiency although, that is not all of it. Creating a system that provides for service, comfort and a base for economically beneficial decisions is at least as important. A Chinese research report concerning scientific management of building energy efficiency mentions that "*...building energy-saving work is not only research and extension of certain technologies or manufacturing of products or measurements...*" and points out that building energy efficiency systems should also consider the residential culture and way of living. This report concerns the development in China. Thus, all countries should consider their own original systems, ways of living and assets in order to reduce the unnecessary energy use and create living environment that is as ideal as possible. (Yanpeng 2009)

The type of smart houses handled in this thesis is a house containing energy production, energy storage and load control. These DER are to be handled by an EMS to achieve the lowest possible social costs and highest energy efficiency with maintained level of comfort.

### 2.3.1. Scientific management

Indoor climate systems of today for heating, lightning and ventilation are built and managed upon a large part of assumed values and coefficients in sizing of equipment and nevertheless assumptions of human behavior. This extensive management and system settings result in unnecessary waste of energy and an increase of environmental stress. Research has showed that a reasonable temperature and scientific management of ventilation can provide a more healthy and comfortable indoor environment as well as saving energy. (Yanpeng 2009)

Measuring quantities like temperature, air quality and consumed electricity makes it possible to grasp real-time quantitative changes in energy consumption related to indoor climate and activities. By measuring building equipment systems and subsystems and by analyzing the measurements it becomes possible to find energy-saving potentials and unreasonable energy solutions.

### 2.3.2. Building Energy Management Systems

When creating an effective load management system there are several aspects that have to be taken into account. One central issue is the end-users attitude towards energy usage related to the energy price. In other words, how much the end-user is willing to pay for a service at a given time and which type of energy source that provides for the best price at the moment. What kind of appliances the end-user possesses and how they should be prioritized, their critical levels and maximum interruption time, load profiles of different appliances and the possibility to change it in response to price and system signals is to be considered. (Mauri et al. 2009)

Pedrasa (2009) mentions that the value of energy services is based on the comfort and convenience that products and profits bring to the end-user. This is affected by several factors like time of day, weather, social externalities and a large part of uncertainties. In order to achieve the above mentioned targets of functionality, comfort and energy efficiency different kinds of optimization methods can be used. Two types of optimization perspectives will be further discussed; value based optimization and price based optimization. (Pedrasa 2009)

The optimization model presented by Pedrasa (2009) is based on value of a service to the user and the users demand for the service, which changes with time. Pedrasa uses a restaurants hot water usage as an example. The restaurant generally has a demand for hot water from some time before opening, while open and some time afterwards. The restaurant owner is probably willing to pay more money per 1 unit of thermal energy needed to heat the water when the restaurant is open than when it is closed. Pedrasa proposes that the workers at the restaurant do not care about how many kWh the water heater consumes, but how they benefit from the hot water and the convenience it provides, the service they receive in other words. (Ibid)

Therefore the value of the hot water service is assigned to the thermal energy content of the hourly demanded hot water, instead of the energy consumption of the heater. This is later corrected by a performance of operation coefficient representing how much energy

different heaters need to achieve the same service. The thermal energy content of the water relates to the energy consumption of the heater through the formula (Ibid)

$$U_{ES}(t) = \eta \cdot P_e(t) \quad (1)$$

where  $U_{ES}(t)$  = thermal energy content of the water (kWh)

$P_e(t)$  = energy consumption of the heater (kWh) and

$\eta$  = performance of operation coefficient.

The value of the service,  $\lambda_{ES}(t)$ , is the momentary amount the end-user is willing to pay for getting the service provided or the amount lost if it is not. The demand for hot water and the value the restaurant owner put on it is visualized by Figure 9. How  $U_{ES}(t)$  looks depends on the user-habits, demand can be high at periods when the value actually is low and the other way around. For shiftable services like cooking or washing and curtailable services like pool pumping, it might not be possible to draw a demand curve. In that case sets of conditions are given like; the washing machine needs 1 kW of energy and can start anytime between 9 and 15 o'clock. (Ibid)

This modeling technique is made for instant use of the energy service. With appliances that consume energy and stores the energy in some shape for later use this model is not optimal. In that case there is a mismatch between the demand for the service and the electricity consumption of the end-use service. In the simulation this problem is solved by using  $\eta = 1$  and the actual service is activating the energy storage of interest. In this case an energy service simulation platform was created where the goal was to maximize the net value of the energy services desired by the end-user. The simulation platform considers usage of real time prices signals,  $\lambda_e(t)$ , (time of use and real-time tariffs), DR and suggests an optimization strategy for operating available DER. It aims to minimize cost of electricity consumption while delivering demanded service. The platform also quantifies the savings made by using DER according to the proposed strategy, from which investment decisions can be based.

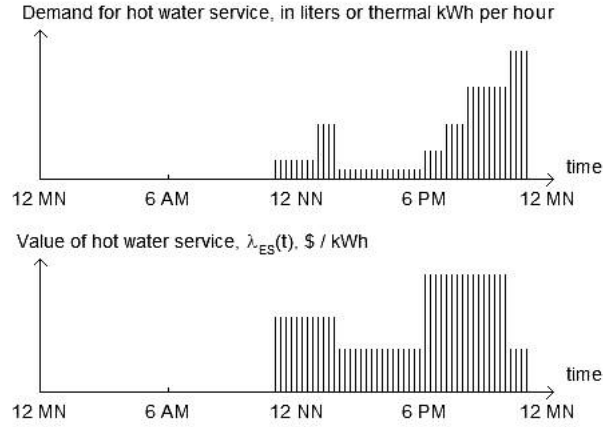

**Figure 9.** Representation of energy service demand and value of the restaurant. Demand for hot water in the upper graph and the amount the restaurant owner is willing to pay in the lower graph. (Pedrasa 2009)

The optimization platform is basically a mathematical optimization problem calculated over an hourly time period for a number of services subject to the operational constraints of the DER. An optimized schedule of operation of DER is searched for by considering end-user values, energy obtained, price signal and energy consumption of devices through the formula (Ibid)

$$\max \sum_{t=1}^T \left( \left( \sum_{i=1}^S \lambda_{ES,i} U_{ES,i}(t, x) \right) - \lambda_e(t) P_e(t, x) \right) \quad (2)$$

where T = hourly time period (h)

S = service

x = DER.

Since there are passive storages present, the relationship between energy contained and energy consumed the complex DER operation models with active storage system brings complexity to the optimization problem which becomes non-linear, non-convex and non-continuous. That is why a simulation-based heuristic technique is used to find optimal or near optimal solutions where different data points try to reach the best possible solution, given certain criteria and search schemes. (Pedrasa 2009)

A price based optimization again, chooses energy source according to price of different energy sources. Mauri et al. (2009) tested a dual heating system consisting of heat pumps and a gas heating generator in an active test house using an EMS for optimization of DER usage. The EMS in this optimization also considers the customers attitude towards use of energy as a function of the price, a list of appliances and their priority, their criticality levels and their maximum interruption time, load profiles of different appliances and the possibility to change it in response to price and system signals.

In this case the efficiency coefficient of the heat pumps,  $COP_i$ , varies mainly according to outdoor temperature and humidity:

$$COP_i = COP_n \cdot K_t \quad (3)$$

where  $COP_n$  is the coefficient of efficiency given by the manufacturer and  $K_t$  is the outdoor temperature. In the simulation Mauri et al. used a flat rate electricity price and found a given temperature for when the heat pump would be switched off at a certain low outdoor temperature. The dual system would give some economical saving and the authors point out the need for a network signal to avoid overloading of the distribution grid. A real time price and a network signal would provide further functionality for the price optimization. (Mauri et al. 2009)

### 2.3.3. Smart home devices

Load control can be achieved relatively simply without using any type of smart house infrastructure or communication. This by simply detecting frequency changes in the power grid, through the electricity plug since the grid frequency drops when load rises. That kind of simple load reduction at critical load peaking situations is a simple solution with potential. But driving such technology forward would also negate an introduction of supplementary appliances that would be connected to the smart house structure and benefits like remote control and monitoring, advanced and customizable demand response functions, smart grid coordination would be lost. Not to forget other value added services that

will lead to even better demand response function opportunities and communications services that facilitates the new revenue and relationship drivers. (Lewis 2010)

By adding communication technology to appliances, thermostats, heating and cooling systems they can be used in an intelligent way. Signals from these devices must be collected by a coordinating device, a gateway that coordinates communication within the home and the outside actors like grid owner and other service providers. The gateway contains a home area network (HAN) control ability and could be embedded in the AMM meter. However, to provide a long-term added value service a powerful gateway is necessary. It must be open, upgradable, easy to replace and sufficient for the job of controlling a home all of the services and tools. With simpler services a simpler gateway can be used but that will not result in a long-term value offering. (Lewis 2010; Leeds 2009)

Philip Lewis believes that the means of communication between the gateway and the end-user is expected to be of wireless type within the home and internet. There have been discussions whether to use internet or a PLC approach towards communication with service providers. The internet solution gives better speed and flexibility and leaves control of the home in the hands of its owner. PLC on the other hand is more robust and could be used for load control in critical loadings situations. There is yet no standardization within communication protocols but some of the most usual standards mentioned are ZigBee and Zwave. The most in-home solutions are expected to work by several standards in the coming years. (Ibid)

Smart appliances offer their users advanced functionality in a wide area of in-home services. But the big mass of end-users will probably not change a perfectly good, relatively new home appliance just in order to achieve this. Smart appliances will not penetrate the market for years to come. In the mean time regular appliances can be controlled in a smart way by the usage of smart plugs, thermostats, sensors and switches. Today the price of such equipment is rather high, according to the research conducted by Philip Lewis a smart plug costs about 30-60 Euro. But according to the same research non-European or US manufactures claim they could manufacture smart plugs for European use for as little as one Euro. This is an extreme claim, but shows an illustration over price



development in the area. This equipment needs to at least be reliable, safe, small, energy efficient and nice looking in order to be attractive on the market. But their presence is necessary in order to create a sophisticated smart home solution. (Lewis 2010)

#### 2.3.4. User interfaces

Today there are already a number of available end-user services. These services typically offer the end-user information on residential energy-usage. There have been many pilots for testing different display options for daily and real-time total consumption and a variety of more or less advanced displays can be found on the market. The displays are generally showing electricity consumption either in a monetary consumption of kW or a total consumption of kWh for a longer period. The consumption is shown in numbers, as speedometers or as staple diagram. In most of these displays the time resolution can be altered, providing users with real-time and historical information on their energy usage. These displays can be connected to a central display or detached and then receive consumption data from sensors or the AMM meter. They can also offer the end-user several other types of data like in- and outdoor temperature. The basic idea of the user displays is to make the users aware of their consumption habits. Some of the displays even have support for some remote control of appliances.

Verschueren (2010) distinguish two types of solutions:

- **Local in-home solutions**, which have no connection to a public communications network.
- **On-line solutions**, where the energy dashboard is connected to a service provider in the public communication network

These types of customer interfaces are one good step towards customer interaction and will be further discussed in the chapter on the Smart house functionality. Common for these services are that they provide real-time information on energy usage and some of them can even be used for remotely turning appliances on and off. However, they lack control algorithms to steer devices in an intelligent way, based on real-time information on local energy production, energy tariffs and the flexibility of energy needs.

### 3. CUSTOMER INTERCATION

When communicating information about smart grid and smart house technology to the end-users it is important to consider who the end-user really is and what kind of information is relevant to that person. In order to get some insight in this and to generally investigate how people of today live, what level of knowledge people generally have concerning energy and energy consumption, what communication systems are mainly used today and what the trends looks like has been investigated.

A well known concern when introducing new technology to the market is naturally if and how the public will receive and accept it and hopefully make it a part of their lives. Different innovations take different time before they are accepted in society and sometimes this can be a difficult process, even when the innovation has obvious advantages compared to prior systems. Some innovations spread fast over a wide area, while others take longer time to get accepted or adopted if that even happens at all. This is a struggle to most companies and authorities when introducing new ideas, products or procedures to the market. All of these can be referred to as innovations. (Lindstedt and Mårdsjö Blume 2008)

When a new innovation is introduced it does not matter if it really is new, what matter is how people experience it. Smart house technology, the opportunities and functionality provided by smart grid technology is a new innovation waiting to be introduced and accepted by the public. The technology is not all new and ideas like saving energy, home automation and producing own electricity has been present for a long time. But things like being able to sell energy back to the grid, interactive user-interfaces and giving outside parties or/and automation systems access to controlling home appliances is new functionality to the public. One of the big questions is how to communicate all of this to all parties in the system in order to make it spread over a wide area, in appropriate speed.

There are a lot of questions circulating concerning how to get these functionalities accepted among end-users. But is that really the only obstacle? This is also an innovation that changes functionality of the whole electricity supply system and has to be adopted

and accepted by the electricity industry. DGO's have been used to deliver electricity from a few large energy producers out, to many end-users. End-users that have behaved in the same passive and predictable way, one-directional power flow and limited interchange of information. When adopting smart grid and smart house technology DGO's and the electricity supply industry have to change the way they see end-users and how they communicate with them.

This means that the same technology is involved but the functionalities of interest and how they will be experienced are different towards DGO's and all of the electricity supply industry than what it is towards the end-users. The technology implemented in the electricity grid is the same, but the innovation it creates is different towards the two different sides of the point of connection. This means that implementation of the same technology has to be communicated in different ways to these different parties. This thesis is however focused on the end-user side of this issue. A model for diffusion of innovations in societies by Everett M. Rogers will be used to describe how the public, a social system, adopts innovations.

### 3.1. Rogers model: Diffusion of innovations

Rogers' model for the diffusion of an innovation describes how an innovation is spread through different channels and finally is fully accepted and becomes a natural part of end-users lives. In literature the word 'adopt' is used to describe what happens when people accept an innovation. The four main parts of the diffusion of an innovation is the innovation, communication and the communication channels, the time this takes and the members of a social system.

#### 3.1.1. The innovation

Rogers explains that "*an innovation is an idea, a practice, or object that is perceived as new by an individual or other unit of adoption*". Whether the idea is objectively, actually new, in scale of time since it actually was invented or introduced doesn't really matter. What determines this is the individuals' reaction towards it. If the idea seems new to the

individual, it is an innovation. A new innovation does not have to involve new technology or be new to the rest of the world. Some may have known of an innovation but just haven't created either a positive or a negative attitude towards it, nor have adopted or rejected it. Rogers explains that *"newness in an innovation may be expressed in terms of knowledge, persuasion, or a decision to adopt"*.

Rogers has mainly analyzed technological innovations and mentions the accustomed habit of using the word innovation as synonym to technology. Technology usually consists of hardware, mainly a set of components and a frame that protects them from the outside, and software, consisting of the information base for the components; coded commands, instructions and manuals that makes the components perform desired tasks. We often think of technology as only hardware and consequently, some technology mainly consists of hardware. Still, technology almost always consists of a mixture of hardware and software.

A technological innovation usually has some degree of benefit to its potential adopters. But this advantage is not always that clear to the adopters who are not always that certain that the innovation represent a superior alternative to the practice it replaces. This is at least the case when people first hear about an innovation. A potential benefit of an innovation makes people learn more about it, in order to find out how the innovation works and how it finally could affect the situations of an adopter. Rogers points out that *"the innovation-decision process is essentially an information seeking and information-processing activity in which an individual is motivated to reduce uncertainty about advantages and disadvantages of the innovation"*.

Innovations have different characteristics that directly influence the depth of their adoption in society and how long period of time this takes. These can be divided into the five following categories.

- **Relative advantages.** An innovation is seen as an improvement of previous method used. The grade of improvement is seen through the end-users eyes and the advantages can sometimes be measured in economical terms. But social prestige,

comfort and satisfaction are also important factors. Better advantages give faster adoption.

- **Compatibility.** Handles how well an innovation agrees with existing societal values, and potential end-user previous experiences and needs. An innovation that clashes with the society's norms and valuations will not be accepted as deeply and fast as one that agrees.
- **Complexity.** This refers to if the innovation is seen as difficult to understand and use. New ideas which are easy to understand and use are more easily adopted than innovations which demand personal involvement and development in knowledge and understanding. This has little to do with whether the technology behind the innovation is complex or not, but how the user experiences it.
- **Trialability.** Is it possible for the end-user to at least to some extent experiment and play with the innovation? The easier it is and the faster the end-user can test at least some part of the innovation the faster it will be adopted. This lowers end-user insecurity and shows that learning-by-doing is a possibility with this product. That lowers the complexity level.
- **Observability.** This handles to what extent the innovation is visible to the end-user and other individuals. The faster the end-user can see the results from the innovation, the more likely it is to be adopted. Observability also triggers conversation between individuals which contributes to spreading the innovation. (Rogers 2003)

Lindstedt and Mårdsjö Blume discuss the new AMM meters in their report and how the introduction of AMM meters relates to the diffusion model. The AMM meters are in most cases hidden to the end-user, they are not visible. They are not intended to be experimented with and what most of the end-users really get from it is a precise electricity bill every month. Consequently, that makes them compatible with the previous system and precise bills are seen as an advantage. Even if some criteria are not fulfilled the two of most importance are. This means that they most probably will be accepted by the social system. However, fulfilling more criteria would speed up the diffusion process. (Lindstedt and Mårdsjö Blume 2008)

The AMM meter is a technology used by grid owners, from the beginning at least, mainly intended to collect monthly measurement values from end-users. The functionality of the AMM meter towards end-users is to receive a precise monthly electricity bill. This is according to Lindstedt and Mårdsjö Blume what end-users expected and this also makes the AMM meter compatible to and an advantage towards the previous system used. What they though found, is that end-users expect the new billing system to spread their consumption evenly over the year and they would avoid the bill that evens out their consumption once a year, which was the case earlier with one estimated and one measured bill per year. These end-users will be let down by the system since the size of the bill will differ according to season which might be hard to cope with for families with electrical heating and a strained economy. (Ibid)

According to how the technology is used, different functionality towards the end-user can be achieved and at the same time change the innovation; how end-users experience the innovation. The AMM meter can be included in a larger system introducing more and/or different functionality towards the end-user which gives the innovation changed characteristics according to the diffusion model. If too much functionality, which is hard to use or understand is introduced the complexity level rises. This demands for a higher level of involvement from the end-user and limits the diffusion.

### 3.1.2. Communication channels

Messages travel from one individual to another through communication channels. Mass media communication channels are very effective in spreading knowledge. Interpersonal channels are even more effective in forming or changing attitudes towards new ideas which, influences the decision whether to adopt or reject an idea. Most individuals do not base their decision of adopting innovations on scientific research but on stated opinions of near peers who have adopted the innovation. Rogers also mentions that new media affects communication in a positive way. (Rogers 2003)

### 3.1.3. Time

Different kinds of people have different interest in and ability to adopt innovations. The diffusion of innovation process explains the process in society of accepting and adopting an innovation. The process includes the time it takes from when an individual first hears of the innovation, to form an opinion of it, take the decision whether to accept or dismiss the innovation, implement the new idea and finally confirm the decision. In this process people are divided into five categories (Figure 10):

- **Innovators.** People who actively search for information and new ideas. These people need economical assets and the ability to understand and implement complex technical knowledge. These people have the ability to handle insecurity and are seen as gate keepers in the flow of innovations. This is a rather small group of people and consists only of 2,5 % of the big mass.
- **Early adopters.** This group of people is better integrated in the society than innovators. They act as creators of public opinion since they are seen as intellectual people in the society. These are the role models in society and consist of a larger group of people than the innovators, 13,5%. This is the group of people companies usually aim at for recognition since innovations approved by this group is generally also approved in the society.
- **Early majority.** This group of people picks up innovations just prior to an average person. This group is also considered important since it is rather large, 34%. This group is together with early adopters considered to be the critical mass when innovations are introduced.
- **Late majority.** The people in this group are skeptical towards innovations and pick up on them right after average people. This group of people also makes out 34% of the big mass.
- **Laggards.** The last group of people to pick up on innovations. The people in this group are traditional and like the way things used to be before. These people often have a limited economical situation and have to be extremely cautious on what they buy. (Rogers 2003)

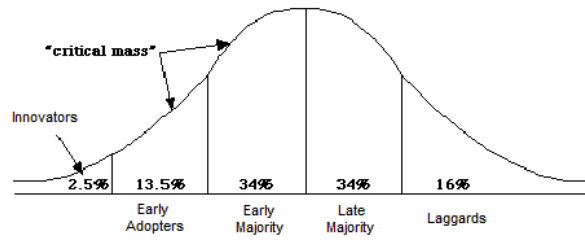

**Figure 10.** The bell curve shows the distribution for different types of social groups in society. The figure also shows what groups are considered to be the critical mass in the adoption process. (Rogers 2003)

If a person decides to adopt an innovation also depends on how involved the person is. Lindstedt and Mårdsjö Blume discuss involvement and mentions three different kinds of involvement which all could be high or low.

- Involvement by opinion is about choosing to take a side and having an opinion. Like who to vote for in an election, to take a stand, weather to support something or not.
- Decision based involvement is about a message, a decision or an intention. An example of this could be buying a device or taking an action based on something seen in an advertisement.
- Involvement in a subject. Is about getting involved in a certain subject or area, like the environment, a hobby or economy.

When considering involvement in the subject of energy consumption, the individual consumption or just overall on usage of energy, that would be involvement in a subject. It could be a high or low involvement. Decision based involvement would be taking the decision to turn off appliances that are not used and buying energy efficient appliances. It could also be a decision to get involved in the subject of energy and energy consumption after receiving an especially high electricity bill or an information leaflet on energy consumption.



If a person decides to get involved in an innovation depend on how the person experiences the innovation. Changing the characteristics of an innovation will change how the innovation is experienced in society. A higher knowledge about a subject gives a higher degree of involvement in the subject. This raises the probability for a decision based involvement. An involvement by opinion would be having the opinion that taking energy efficient decisions is important to save the environment. (Lindstedt and Mårdsjö Blume 2008)

#### 3.1.4. Social system

All of this takes place in a social system, consisting of a group of people with a joint problem solving in order to accomplish a common goal. The system has structure, a pattern of arrangements of the people in the group, which give stability and regularity to individual behavior in a system. The social and communication structure of a system decides the diffusion of an innovation within the system. One example of a social structure is norms, which establishes patterns of behavior within the group. Opinion leadership is the degree of which an individual is able of affecting other individuals' opinions of an innovation in a desired way. Rogers lists three types of innovation-decisions:

- **Optional innovation-decisions.** When an individual decides whether to adopt or reject an innovation independently from other members of the social system.
- **Collective innovation-decisions.** The decision of adoption or rejection is taken in consensus with the other members of the system.
- **Authority innovation-decisions.** The decision is taken by a few individuals in the system that possesses power, status or expertise.

The decisions whether to adopt or reject can also consist of a mixture of these categories. Finally the social system is also influenced by consequences, the changes that occur to an individual or social system as a result of adopting an innovation. (Rogers 2003)

All of the above mentioned factors are matters that should be taken into account when communicating smart grid and smart house innovations to end-user and within the electricity industry.

### 3.2. Customer behavior

In order to be able to create a fair opinion towards a new idea, product or procedure, an innovation, one must also be able to understand it. If some part included in the innovation is not clear to the adopter or misunderstood the communication system is complicated. This has to be paid attention to when communicating innovations to end-users. The communication has to be at the same level of knowledge as the adopters.

Lewis (2010) describes how to communicate the smart grid and smart house technology to end-users, *"It is important not to see smart home or home energy management systems as simply, or even primarily a means of helping customers to save energy, money or the environment. These three benefits are undoubtedly important, and should be promoted prominently, but alone they are proven to be a poor motivator within the context of the incurred cost and hassle faced by customers who are being offered such offerings.*(Lewis 2010)

The diffusion model mentioned in the previous paragraph can be used in order to be able to shape the innovation to best suite the adopters. The AMM meters were implemented due to a decision taken by the government. The decision only describes the functionality received by end-users, the monthly precise bill. It does not describe which technology to use, but AMM meters is the system adopted to achieve that functionality. (Lindstedt and Mårdsjö Blume 2008)

The technology behind AMM meter possesses much more functionality opportunities than that, towards DGO's, electricity retailers and other players in that area of business and towards the end-users. In order to find functionality that would be favorable and useful to end-users literature on how end-users in the electricity grid behave and what is valued in the society is reviewed in following sections. Facts on gain in popularity of technology innovations that could be utilized in collaboration with smart house technology, customer types and the perspective in society on energy and energy consumption is also considered.

### 3.2.1. Telecommunication trends in Finland and Sweden

The strength of smart house technology is the possibility for flexibility of control for end-users of their homes. In order to investigate end-users interest in mobility and internet based solutions statistics and trends of internet and mobile phone usage is discussed.

During the past year there has been an explosion in usage of mobile data services in Sweden. According to statistics from PTS, the Swedish Post and Telecom Agency, the data transferred mobile networks was doubled in the year of 2009 compared to the year of 2008. During the same time the number of mobile internet subscriptions was increased by 50 %. From this could be read that not only are the amount of mobile internet subscriptions increased, but the amount of data transferred per subscription is also increased. (PTS 2010)

This interpretation is also supported by statistics in the report, "*Telecommunication Markets in the Nordic Countries*", which is a gathering of telecommunications statistics from the Nordic countries. That report also says that the total amount of mobile phone call minutes per subscription is actually lowered in Finland and the number of sent text messages is about the same, when statistics from 2009 is compared to statistics from 2008. It can further be read that the amount of data sent per subscription is rising even more rapidly than in Sweden. The same statistics from Sweden is that the total amount of mobile phone call minutes per subscription, per year, is still rising but not as fast as before. The amount of sent text messages is still rising in Sweden and the amount of data transferred per subscription is also rising steadily. (FICORA 2010)

From this can be found that mobile users in Finland and Sweden are losing some of their interest in making phone calls from their mobile phones. In the same statistic it can also be read that the total minutes of phone calls made from fixed telephones is also lowered. Instead Finnish mobile telephone users have moved over to using internet connections.

A report from Statistics Finland shows that instead internet services like social media like Facebook, Twitter or MSN and emailing are more frequently used as social media. This is most popular among the younger age groups. 76 % in the age group of 25-34 and 44 %

in the age group 35-44 are registered at some kind of social internet forum. According to the research done for the Swedish statistics portal, PTS, 22 % of the Swedish people use their mobile phones for social interaction, which is a double increase from the previous year. However, internet is also more frequently used in service. 22 % use their mobile phones for booking tickets which also is a significant increase from the previous year. According to Statistics Finland 76 % of the age group 16-74 years uses web-based bank services. 73 % of the people in that age group have used internet to search for information about products or services, 74 % reads new papers on internet and 41 % buys product over internet regularly. The same report also says that over 15 % of men in the ages of 25-44 years and over 10 % of the women in the same age group uses internet on 3G mobile phones. (Statistics Finland 2010 b; Nelledvad 2010)

The statistics show an overall increase in most areas of mobile and internet media in the Nordic countries and in some areas the increase is rapid. People have an interest in using mobile devices and people are increasingly moving part of their lives over to the premises of internet. By using mobile internet devices people have experience better service and flexibility, errands and social activities can be performed whenever there is time and need. Not limited to the fixed internet connection in their homes. This can be expected to increase together with an increased use of smart phones which provides better flexibility and functionality. Faster mobile internet connection named 4G is now launched in the major Nordic cities adding to rate of increased mobile internet usage.

### 3.2.2. End-user segmentation

The Danish energy company SEAS-NVE conducted an energy efficiency campaign based on segmented customer information. By actively participating in the campaign, by sending in their monthly meter readings, customers could win 6 700 € 40 000 residential customers participated. The meter values were sent in to SEAS-NVE through a webpage. In this page the participants of the campaign were also prompted to give other data about themselves and their house. Further the web page gave the customers educating energy saving tips and information on how their saving was preceding. (SEAS-NVE 2010)

Prior to this campaign SEAS-NVE researched within the area of customer behavior and interviewed their customers based on information material sent to them, in favor of segmenting the customers. Different types of customers view and comprehend information in different ways. Based on all the information gathered through this campaign, SEAS-NVE divided their customers into four different groups.

- **The basic**, 40 % of their customers.
  - Customers in this group are pretty traditional and conservative. They value safety and stability and want a stable electricity supplier. They want the energy supplier to focus on the core area of their business and think it is important with a customer owned energy supplier. This group just wants straight information on how to reduce their energy consumption and what they need to do it.
  - This group mainly consists of men in an average age of 50 years, households with 1-2 people and retired people.
- **The critical**, 24 % of their customers.
  - This group is very critical about what they buy and they want forthright information instead of pleasant "chitchat". These people want to be challenged and amused, but are not very loyal and will go with the company that displays the best offer. Just a few of them are confident that the energy supplier would give them qualified energy saving tips.
  - This group mainly consist of people under 35 years of age, are privately employed and tradesmen.
- **The dreamer**, 20 % of their customers.
  - The people in this group are very emotional and can be a bit flighty. They often have a creative mindset and appreciate innovation and new ideas. This group thinks it is important for the energy company to supply other products than energy and have en higher confidence in customer owned companies.

- This is a group of consisting mainly of women from below 30 years up to 50 years of age. These people are publicly employed or students and work in the health sector or own a farm.
- **The Local**, 16% of their customers.
  - This group of people thinks small is a good thing and think local aspects are important. They also have clear views on environmental issues and think being 'green' is important.
  - This group mainly consists of women, engineers and high income people.

The internet page for collecting meter values from the end-users was said to be successful since it contained different elements that were appealing to all of the groups. Different types of people have different interests and valuations. Displaying these in various shapes and ways can make an offering appealing to several different groups of people. Alternatively different solutions can be made for different groups, based on the same technology.

### 3.3. The society's perspective on electrical energy

The authors of a Swedish report investigating what end-users expect from the AMM meters and what knowledge they have about electricity and energy. The report is based on interviews with strategically selected people in different ages, education levels and society groups. The difficulty to gather participants for a research concerning the individual knowledge on energy consumption and personal habits surrounding that is also mentioned. This has also been the case in other similar researches by the same authors. The authors speculate in weather it was because energy consumption and decision making in the area is not an interesting subject or if it is considered a highly personal and private matter. In researches done regarding professional matters gathering of participants has not been a problem. (Lindstedt and Mårdsjö Blume 2008)

Another fact mentioned is that based on the results from their research is that some of the participants seem to be ashamed over their low level of knowledge in the subject. The participants thought they should have deeper knowledge on the subject and felt like out-

siders when they didn't. Introducing new technology messes around with social structures and provides for new platforms and meeting points where authority and lack of authority is at stake. Knowledge becomes an important factor and new groups are formed within the society; the experts create new groups that easily exclude people with lesser knowledge. Being a knowledgeable person becomes a social benefit. People with less knowledge find themselves object to jokes, irony and disrespectfulness. This is a classic, strategic grouping phenomenon where the other group is made fun of in order to elevate the own social group. This has never been a successful way of creating interest for involvement in a subject among people with less knowledge and really does the opposite; it creates dissociation instead. By creating a technology solution with different possibility for levels of complexity the innovation can be made appealing to a larger group of people.

In their research Lindstedt I. and Mårdsjö Blume K. concludes that based on the result from their interviews it is apparent that people generally have a low involvement in energy related topics. They state that people have a low knowledge in the area of energy and energy consumption and feel that they do not have high enough understanding for the physical unit of measurement, 1 kWh, to get involved. Even if Swedish grid owners have taken a step forward in providing the end-users with monthly consumption data, these people still have problems with understanding their consumption since it is a whole month worth of energy consumption. A raise in the level of understanding and knowledge is still needed in order to understand what contributes to the total monthly consumption of a home. (Lindstedt and Mårdsjö Blume 2008)

Energy and what that is can be very hard to grasp among people. Swedish research shows that very few people understand the relation between energy, kW, and energy consumption kWh. An even smaller group of people are able to determine what can be seen as a big or small number of kW and kWh. If people are to change their behavior and change their ways in order to save energy they would have to get involved in the subject of energy consumption. (Bartush 2009)

### 3.3.1. Electricity consumption and feedback practices

*"Electricity is consumed as an invisible bi-product of whatever is the main activity. Customers do not consider reading a book as an electricity consuming activity. However, it often is. Electricity is consumed when customers talk to friends in cars on mobile phones, when they take a shower, when they make toast. Yet, as electricity is never the focus of these activities, customers are unaware of the direct impact it has on their consumption."* (Strömbäck et. al. 2010)

With a billing practice where the consumption is estimated and adjusted by season, the end-user is prevented from realizing that their own actions together with seasonal changes like change in temperature and daylight add up to a higher electricity consumption during the winter months. The connection of what happened in January cannot be connected to a bill in October. This situation has now been improved by the introduction of the AMM meter and a monthly electricity bill based on actual consumption. (Ibid)

As mentioned there are different reasons in the society for saving energy. When the individual considerations are at stake three different, notable motives or factors can be distinguished; the environment, the personal habits and the personal economy. When it comes to personal habits they can be changed over time, but for that to happen people must become more aware of their own consumption. People are generally not aware of what cause their total consumption. Even if people would be well aware of what energy is and the concept of kWh it can be hard to estimate how usage of different appliances actually will sum up to over time. The third motive, the economical point of view, is more interesting to a larger group of people and when that is the reason for saving energy, there is also a larger need for control over and insight in the personal consumption. (Bartush 2009; Lewis 2010)

Using energy is a complex thing and the relation between kW and kWh might not be that easy to grasp in everyday life. In her report about how to visualize energy consumption Bartush writes that when monetary energy is displayed, W or kW most of the test persons started to find out how much each appliance consumes by reading the momentary value



from the display before and after turning appliances on and off. This shows their interest in finding out how much energy different appliances consume. Thus, they were not able to relate the momentary consumption to how long time each appliance is used per day and what that respectively would make in kWh. Bartush enlightens two examples of this in her report. One case where the test family decided to buy a new vacuum cleaner as a result of noticing a high momentary consumption and combining that with the fact that they use it used daily. The family did not reflect over the fact that it was used only for very short periods of time and it did not contribute to a high total consumption. Another where the same family realized that their TV had a high consumption and was turned on most time of the day. Based on that insight they started to turn it off when it wasn't really used. When bar charts are used both on the central display the end-users are able to relate to the bar chart on their electricity bill. (Bartush 2009)

Some people seem to find it easier to relate to price information since they are familiar to the size of their monthly electricity bill. Showing information in the shape of a given currency can be coherent with a set electricity price. But if the goal of displaying household consumption is to lower the consumption this becomes indistinct when a price signal based on current electricity demand.

It has also been experimented with showing consumption in Watts. That would generate a larger number, which might be taken more seriously. What was found from that is that the users did not really relate to the number but they rather compare consumption from one day to another. When data is displayed by some type of bars people are accustomed with a values or size of the bar which is related to as a normal daily consumption. In this test the users followed the changes in their daily consumption by looking at the bar chart. In research by Elforsk test persons also showed interest in finding out how their consumption was divided between heating, lightning and all their home appliances. (Ibid)

#### 4. INVESTIGATION ON AREAS OF INTEREST TO THE CUSTOMER

In order to find problem areas and areas of interest to Fortum customers, incoming phone contact to Fortum has been investigated. The aim of this investigation is to find out what the customers ask Fortum and to find out if some of that information could be utilized for developing new and existing business and functionalities. Incoming phone contact is mainly handled by the customer interaction and service (CIS) department. Additionally phone calls are also received on other direct lines like customer initiated grid services (CIGS) that handles phone calls of a more technical oriented nature, and other separate departments handling network operation, energy guidance, larger business customers and customers damage claims and inquiries. This investigation focuses on customer contact at CIS and power quality issues handled by CIGS as these matters are relevant to the focus areas of this thesis. The planning of the investigation was based on the pre-study presented in Chapter 2 and Chapter 3 of this thesis.

This investigation is based on phone calls made to Fortum by private, small scale customers and thereby does not represent interests of all of Fortums customers. It focuses on the distribution of incoming phone calls between different areas of Fortums business and the customers who have turned to Fortum with some kind of problem-situation which needs to be solved or a strong enough involvement in a subject to take action and make contact with Fortum. That gives some indication of what are central issues to Fortums customer and to what extent. CIS is the department that interacts with Fortums Swedish customers and thereby has a thorough familiarity with regular peoples' perception of energy usage and other related areas.

##### 4.1. Investigation of customer interaction at Fortum

By analyzing statistics on incoming phone calls and by interviewing customer service agents the incoming customer contact to CIS has been studied. Statistics from CIS Sweden was analyzed because that was the only data available which was suitable for a statistical analyze. Interviews with CIS Finland were based on the same statistics in order to be

able to distinguish similarities and deviations. This analyze of incoming phone calls is mainly intended to serve as a base material for the interviews but it also shows how customer contact is distributed between different functionalities within Fortum.

#### 4.1.1. Analyze of statistics for incoming phone calls to CIS

The data concerning incoming phone calls to the service agents at CIS was collected at a daily basis by 20 of the 100 service agents during the first seven months of 2010. These agents registered every phone call in a number of predefined categories. This allows the data to be converted into a statistical percentage per category.

The different categories were grouped according to functionality or association to different processes within the company. The grouping and the meaning of the categories have been discussed with the CIS agents in order to correct the grouping. It was pointed out that customers are often unaware of what their problem really concerns when calling Fortum. They often have an incorrect assumption about the cause of the problem, leading them to ask for an improper solution. This leads to the problem whether to register calls according to customer request or according to which actions were taken. That fact is too complex to resolve in this thesis and has not been taken into account in the analysis. Data has been handled as is.

One target of this study was to find out how many calls CIS gets per month concerning energy consumption and another was to study whether technological or even regulatory solutions could solve problems of Fortums customers. When briefly looking at the statistics it seemed like calls regarding energy consumption represent only about 3.6 % of all calls. That is a low number which could be easily discarded with the conclusion that customers seldom call regarding their consumption.

However, by studying the different categories of incoming phone calls more closely it became apparent that some categories were closely related and should be grouped. By analyzing percentages of different groups instead, other indications became clear. The different groups actually represent different reasons for making contact.

By sorting out the regular, routine calls that Fortums customers must make for different reasons in order to keep agreements and stay supplied. Two major groups appeared, "forced contact" representing 55 % of total, where the customers more or less must make contact; there is a distinct matter to solve. The rest of the calls were labeled "investigative contact" representing 45 % of total, the customer is mainly calling in order to gain knowledge, sometimes used as a base for future decisions related to electricity agreements or the residential electric installation. Both of the major groups are interesting in their own way and both could be solved in some extent by technological solutions.

Figure 11 shows the division of sub-groups in one of the major groups, "forced contact". The sub categories in this group are quite obvious and the largest portions are contacts concerning moving, invoicing - payment and complementing information for invoicing.

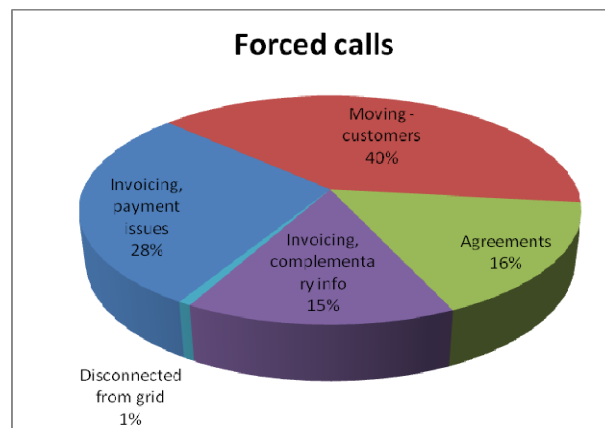

**Figure 11.** Division by category for incoming routine calls made to CIS.

The other major category, "investigative calls", could be more interesting to examine further. What are the customers asking if there isn't really a distinct matter to solve? Could this give clues on areas of new functionality? The largest sub-categories within this major group are questions regarding electricity prices and changing supplier, 38 %, explaining the invoice, 15 %, and questions regarding the residential electric installation represent 14 % of the calls. Some of the categories that are shown in Figure 12 are handled by separate departments with direct phone numbers, but occasionally the calls are directed by CIS.

Questions regarding electricity consumption represent 8% of the investigative calls. Besides this there are also the calls made directly to the energy guidance group and a few calls that some times are directed to the CIGS department instead. There is no statistics for these calls during this period.

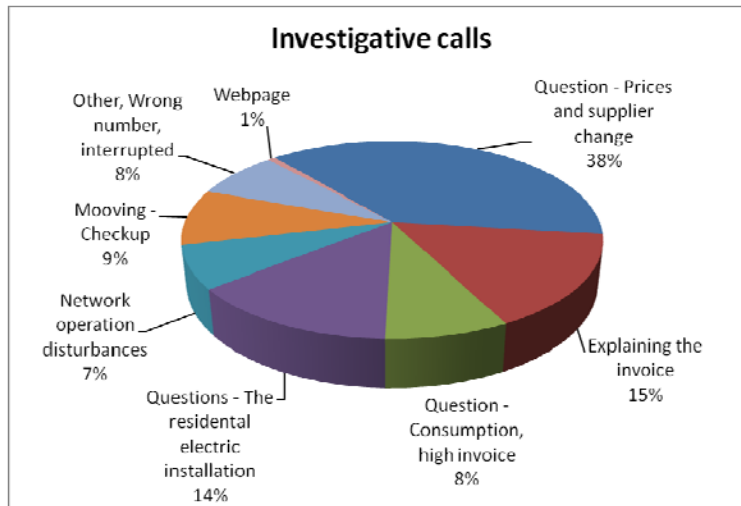

**Figure 12.** Division of subcategories in the group of investigative calls.

Within the group of investigative calls the major separate questions asked and their percentage are shown in Table 1 below. Notice that the table only shows the separate categories with most registered calls. It does not show all categories and there by the percentage does not add up to 100 %.

**Table 1** The percentages of the largest separate categories within the major group investigative calls. Please notice that all categories are not shown here and thereby the percentage does not add up to a 100%.

Percentage	Individual category	Explanation to category
12%	Electricity prices	Questions regarding the price for electricity.
12%	Status of payment, electricity bill	Customers asking if their bill has been paid or not.
11%	Explaining the bill	Questions regarding what the different costs represent on the electricity bill
7%	General question, moving	How to act when moving.
7%	Electricity agreement, status agreement	Status on the present agreement for the customer, ex. what the agreement terms are and when it ends.
6%	Electricity consumption	Questions regarding electricity consumption.
6%	Electricity meter	Questions regarding the electricity meter.

#### 4.1.2. Planning of interviews

It was decided that the interviews would be of free form; they should be shaped as a discussion. This decision was made in order to avoid affecting the agents according to the interviewers own preconceived opinions. The intention was to guide the agents into pre-defined subjects and allow them to talk freely about them. Each discussion lasted about 30 min and answers were to be noted. A few topics per interview were based on the statistics from CIS. This was mainly done in order to check whether the categories had been grouped correctly and to get a deeper understanding to why customers make these calls. There could be overlooked areas of interests to the customers within the groups. Every category could not be discussed with every agent due to limited time and the focus of the interviews should be put on the customers' questions and knowledge within energy usage and smart grid technology related areas.

Prior to and during the interviews the agents were presented with a brief presentation of the smart grid and smart house functionality presented in chapter two. The main goal was to find new angles, points of view and what typical questions or problems are. The questionnaire used as a base for the interviews can be found as Appendix 1. The main questions for every topic were as follows:

- What does the customer ask?
- What is a typical question within this area?
- How does the customer behave in these matters?
- Can the customer understand and accept the information given?

#### 4.2. Customer interaction and service, Sweden

Presenting results from free-form interviews is problematical. The approach taken here is displaying things that were specifically pointed out by the agents. These have been gathered in a main protocol where similar answers have been grouped. The most frequently given opinions and answers considered to be of most significance to the scope of this the-

sis are presented as results. In order to display how unified the answers were it is mentioned how many agents have been asked about each topic. Matters specifically pointed out by the agents were noted on paper and are shown in Appendix 2 and Appendix 3.

These results are to be seen mainly as an indication to what customers generally say and ask for. To get a better statistically defined result a larger group of agents would have to give their opinions. The agents interviewed have been working as CIS agents for some time and have a good insight in customer interaction. As mentioned the aim of these interviews was to get a better knowledge on the customers' questions and level of knowledge, not a statistical distribution of that.

#### 4.2.1. Questions based on the statistics

Within the group of categories concerning customers moving in and out of their homes seven agents has been asked during the interviews. Six of them said that customers have difficulties providing the agents with necessary information. Customers must give some kind of information on which electric installation the move is concerning, id-number of the electric installation, id number of the meter or information on who used to live there previously. Five agents explained that most people are not aware of the fact that they must announce their move to Fortum.

Three agents have been asked about electricity agreements during the interviews. Two of them said that the customers calling about this think that there are too many different tariffs and companies to choose between and two of them also said that customers try to find out whether the current price is competitive. This group of categories concerns signing up for electricity agreements and issues related to that function.

Customers calling just to check Fortums current electricity prices ask questions about the development of the electricity price. Customers often try to negotiate for a better price, but price awareness is varying. This category is closely related to questions about consumption. Customers often ask for a better electricity price when they are not really aware or not interested in the potential of saving money on lowering their consumption

instead. Four agents were asked about this during the interviews and the answers are widely and evenly spread.

Questions regarding the residential electric installation have been discussed with six agents during the interviews. Within that group the most usual questions are customers asking about the size of their main fuse and the id number of their installation, mentioned by four agents. These questions are often closely related to electricity agreements since customers often call to ask the id number when changing electricity retailer. According to the CIS agents customers also ask about their main fuse if they are considering changing it for some reason. The high number of calls within this group indicates that people generally have a low knowledge about their residential installation. From these discussions it was apparent that people generally have a low knowledge about what is their area of responsibility concerning safety issues and ownership. Two agents, who were asked specifically about fuse changes during the interviews, said it to be closely related to questions about electric installations, and mention that customers ask if they can upgrade or degrade their main fuse and how to act when doing so.

From the discussions it was also apparent that a lot of customers are uncertain about the information given on their electricity bill. This seems to be a result of people not being clear about the difference between electricity and distribution fees. Customers are often surprised by receiving two bills when changing to another electricity retailer than Fortum. Two separate bills also make it hard to follow the total costs for consumed electricity.

Questions regarding disturbances in the electricity delivery are received on a separate phone number and were thoroughly discussed, during the interviews, with seven of the agents working on that line. Most agents said that when people lose electricity supply and call in they want to know why there is an interruption, what caused it and how long the interruption will last. Some customers call in several times during longer interruptions, to find out how the work is progressing. They are also very curious about these situations and often it is actually the customers who inform Fortum about interruptions. This is also a fact many customers express dissatisfactions about, they expect Fortum to have better control over the grid by using technology means of today. Four agents pointed out that



the customers from rural areas are often more used to disruptions and thereby more accepting than city customers. The agents also mentioned that customers express more irritation about planned interruptions since they might have influence on those, which is not possible in case of an accidental interruption.

#### 4.2.2. Questions regarding electricity usage and smart house technology

In addition to the questions related to the statistic the agents were first asked about what people generally say and ask for when discussing energy consumption and what kind and what level of knowledge customers have on that area. Secondly the agents were asked about other things that could be related to smart grid functionality. These subjects are not covered by the statistics and it is hard to estimate how many questions regarding these things CIS actually gets.

Most of the agents pointed out that the questions directly concerning consumption are mostly made during and after the cold winter months and that the customers mainly react to the price of the electricity bill. They also say that customers tend to compare their consumption, to the same period other years and to friends and family. The comparisons are often irrelevant and things like type of house, heating systems and different appliances are not considered.

Customers mainly try to take other measures prior to looking over their own consumption habits. Changing electricity retailer, trying to change main fuse in order to get a lower bill or denying the consumption by blaming the meter for being faulty are usual occurrences. Most customers are not very fond of relating their consumption to their personal behavior. Whether the customer is willing to accept new information about this subject varies and, according to the agents, it often is easier to start the discussion when the customer has already been following their consumption for a while. In that case customers have become aware and are more interested in finding out how to make changes.

The main question when people realize that they can affect their consumption and start to get involved is which appliances contribute to which amount of consumption. They start to ask questions about how much electricity different appliances consume. How much

different changes actually will affect their total consumption; where in their house different amounts of electricity are consumed and whether that can be changed. Some agents reflected over the fact that it seems difficult to be aware of invisible electricity consumption. Customers often claim that their consumption has increased even if they haven't changed anything in their house. Through further discussion implementation of large appliances or systems can often be revealed. In those cases the customer isn't aware of the energy demand of the appliances. Apparent is also the unawareness in use of uneconomical solutions. When asked, most agents replied that customers generally have low insight on which appliances they have in their homes and how much electricity different appliances consume. Generally people with lower consumption have less knowledge in that area.

The customers' interest in producing and feeding electricity to the grid was widely discussed. Most agents guessed that they would get about one call per month about this and even if that is only an assumption it would still be quite a few if every CIS agent actually got one per month. Most questions about this concerns wind or solar power and customers are interested in knowing if it is allowed to connect production units to the grid and if it is possible to feed their excess electricity to the grid and if they will get compensated for doing so. Customers wonder how to act, what the regulations are and if there will be costs involved. People asking about this is said to have a will to be independent in electricity supply and often want to be environmental friendly. The group of people asking about this is often enthusiasts and high-income, middle age people who have an interest in environmental factors prior to saving money. Agents consider farm owners to be a large group with interest in producing their own electricity, with interest in security of supply and lowering net consumption.

Regarding environmental awareness the agents felt that this isn't often asked about though, interest is increasing and the questions are mainly asked in connection to making electricity agreements. The customers primarily want to know if the electricity they are buying has a green label. They almost never ask for the geographical place of production, whether it is imported or locally produced. Customers generally care about buying wind or water power instead of electricity produced in nuclear power plants. It was also men-

tioned that people who care about being environmental friendly are the same group of people who care about saving energy.

Load control as of today is an issue agents claim there is a low initial interest in. Most calls about this are from people who have bought a house where the previous owner have used the time tariff. The new owners might not even be aware of the fact that there is an automation system installed for controlling heating according to the time tariff. The opinion of several agents was that most of these people move away from this system, mainly because they do not grasp how to use it in a beneficial way.

Due to the fact that the AMM meters were quite recently employed and play a central role in many smart grid discussions the customers opinions and reactions towards these were carefully discussed. Most questions directly concerning the meter were about how often readings are done and generally about their functionality. The agents also felt that customers were highly affected by media. Most of the complaints were people claiming that it was making noise, regarding the placing of the meter and even fear that it would give out radiation. There was also a lot of skepticism towards their accuracy and that they would even work at all. A lot of the complaints were received from house owners after the winter months. Large groups of people had not been able to anticipate their heating costs during the winter. These people often felt that the meter gave them a higher consumption.

Most people accepted the new meters after some time and thought it was a good thing to get exact values faster. The overall opinion of the agents was that customers have become more aware, if not of their actual consumption, at least of the ordinary level of their monthly cost. What customers ask for in future development is acquiring more meter readings; daily, hourly and real time values. Several agents said that customers also ask for the possibility to see where electricity is consumed, which unit has consumed how much. Several customers expected more from the display and ask for further developed information.

#### 4.2.3. Power quality complaints

The CIGS department handles complaints on power quality reported by customers. Every case is thoroughly investigated according to Fortums in-house routine. In the initial stages of these investigations the customers' point of connection and cables leading to it is inspected in a graphical map tool used for planning changes or service work in the electricity grid and for documenting of the electricity grid, also known as a Graphic Information System (GIS). The grid control performed by using the GIS program is performed in order to identify apparent weaknesses in the grid. There is also a thorough discussion with the customer regarding the characteristics of the disturbances. From this conversation it can often be found that the disturbances origin from disturbing units or under dimensioned or poorly planned cabling in the residential electricity installation. If a problem at customer premises can be suspected the customer is advised to contact an electrician who can do measurements and determine what the problem is. If the customer has already done this or returns after the electricians investigation where no problems can be found a measurement is conducted at the customers' point of connection.

From these measurements can be found that there is a problem in the grid which needs to be taken care of. However, from the graph obtained from the measurement it can sometimes be noticed that there is a problem within the residential electric installation after all. It could be different types of automated units starting and thereby causing flickering. Often this can be identified during the initial phone conversation, but sometimes the customer is really unaware or denying of which units can be found in the residential electricity installation. The problem can also be caused by disturbing units in neighboring installations with units that, by mistake or unawareness, could be allowed to send disturbances to the grid. (Norman 2010)

It should also be noted that sometimes it can be found that the electricity delivered to the customer is within the limits of given standard. But the customer has bought some type of equipment with narrower limits of functioning than the given standard. This causes problems to the customer, but Fortum is still keeping the agreement. (Norman 2010)

As of today there is no data collected that could determine how often the problem can be found in the customers, or neighboring, installations and how often weaknesses in the grid is the problem. All complaints are registered and it is not tracked whether the customer returns after having a look at the residential electric installation or not.

#### 4.3. Customer interaction and service Finland

Since no data similar to the statistical data on received phone calls collected in Sweden was available in Fortums Finnish CIS department, no further analysis could be accomplished there. The data collected is on separate call basis and every conversation would have to be examined. Due to this, and the intention to compare results, the same questions asked to CIS agents in Sweden were used in Finland. The interviews and the arrangements around them were made as similar as possible between countries.

The Finnish CIS department employs fewer agents than the Swedish department. Due to this only five agents were available. Otherwise the organizational structure at CIS is similar in the two countries. The durations of the free form interviews were 30 min and the CIS agents were provided with the same information material as the CIS agents in Sweden. Matters specifically pointed out by the agents were noted on paper and are shown in Appendix 3.

The results from these interviews represent the opinions of the interviewed agents and are only to be taken as an impression of general questions and indications made by customers. Nevertheless, some things were still clearly pointed out by several agents.

##### 4.3.1. Questions based on the statistics

Four agents were asked about the customers questions regarding the electricity bill. All of them pointed out that customers have a hard time understanding the different costs on the bill and are not able to understand the leveling bill. The agents explain that customers try to calculate their consumption but are not able to add up consumption during different date intervals. In addition to this it was also mentioned that even if they manage to sort

this up by consulting the CIS agents, people are seldom able to relate their consumption to what has happened during that period.

When discussing customers moving two out of three agents said that especially customers moving in to apartments are often unaware of the fact that they must announce this to the grid owner. Their opinion was that people moving into houses are aware, while people moving into apartments often believe the attendant handles this. In some cases the customer does not call before the electricity is disconnected.

Phone calls regarding supply disruptions were discussed with three agents. All of them agreed that customers call to ask what has happened and for how long the disruption will last. During these conversations it came up that customers generally have low knowledge and understanding for how the electricity distribution system functions, which adds up to their low tolerance for disruptions. Two agents pointed out that, customers who are not used to disruptions are more displeased and impatient than those who experience them more often.

#### 4.3.2. Questions regarding electricity usage and smart house technology

Most of the subjects discussed within the area of energy consumption and matters related to smart house technology resulted in very similar answers as those received from CIS Sweden. Deviations that were noticed are described in paragraph 4.4. Like the results from CIS Sweden, the things most strongly pointed and things of relevant nature to the investigation will be displayed here. Following topics have been discussed with all of the five agents.

When discussing energy consumption and how customers relate to that, three agents said that customers relate to an accustomed price range of their electricity bill and mainly react to deviations from the ordinary. When a deviation is noticed they contact Fortum and usually doubt the correctness of the electricity meter. The long time period of consumption presented at the bill plus the leveling bill creates confusion. A lot of time and energy is put on sorting out how much electricity has been consumed during which and how long period of time. When this is sorted out the dialogue has already lasted for a too

long time and the customer is no longer responsive to further information. Finnish customers also tend to compare their bill to friends and family without considering different heating and house types. Some customers even blame Fortum for the high sum at their bill and demand a thorough investigation.

People do not consider the fact that adding new electrical devices to their homes and a low outdoor temperature will add to the bill. Four agents explained that in most cases of customers consulting the agents about their electricity consumption, the central question is what consumed how much electricity. These customers are not able to and sometimes not willing to see the connection between their own everyday habits and the amount of consumed electricity. The fact that people mainly notice visible consumption was mentioned and that there is very low knowledge about energy flows. People often expect heaters to be able of only heating a limited, unclosed space, which is not physically possible. Some people do not realize devices with an obvious high consumption like e.g. heated swimming pools or they consider only the heating and forget about additional equipment and devices used simultaneously. Other times it is just several devices with a small consumption used for a large part of the day that adds up. Not realizing that broken equipment has an increased consumption, since it can no longer function in an optimized way, was also mentioned.

When talking about customers who want to produce their own electricity all agents said that the main questions are if they are allowed to feed electricity to the grid and if they will get compensated for doing so. There are not a lot of customers asking for it, but it happens and mainly concerns wind power. Customers wonder if they can sell to neighbors and if the electricity price will rise over time. In that case investment costs would be covered in a shorter period of time. These agents think Fortums customers are mainly interested in lowering their net consumption when considering investing in an electricity production unit. The main group asking about this is house owners, enthusiasts and people wanting electricity for their summer houses.

In connection to customers producing electricity, buying environmentally friendly electricity was discussed. According to the agents there is an increased interest for this but

mainly from certain customer groups and especially from people living in smaller societies. These customers are not interested in what kind of production type is used as long as it has a green labeling.

Two agents especially mentioned the AMM meters and said that customers are waiting for them to be implemented. These people want a better control over consumed electricity and often ask for real-time hourly measurements. Load control by use of time tariffs in use today was mentioned by two agents who mainly explained that this is mainly used together with an automation unit controlling water heaters. This system is rarely used these days and the agents believed this is since they do not understand how the electricity distribution system functions and cannot see any benefits from using time tariffs. When further discussing the possibility for automatic disconnection of customers agents were very skeptical towards customers allowing a total disconnection. But still believed customer would be interested in shortened outage times and pointed out that customer benefits then would have to be very clearly communicated. It was also mentioned that customers would have an interest in a possibility to remotely disconnect devices.

Finally it was discussed what kind of information the agents would find interesting to customers. Agents said that customers are generally interested in several different kinds of information; customers want to know what is going on. Some agents explained that sometimes customers are even irritated by the fact that they feel they are not getting any information at all and are not able to affect what is happening in the grid and overall within the whole electricity delivery system. Specific information mentioned mostly concerned information regarding disruptions, before and after but also information regarding power quality. Customers are interested in what they actually get for their money.

#### 4.4. Reflection over noticed similarities and deviations between the countries

When comparing the interviews conducted at CIS, Finland and Sweden it was noticed that the agents had very similar answers and seemed to experience the customers and



their questions equally. But there were still some outstanding deviations which will be discussed in the following sections.

The most apparent difference between the countries is the fact that Swedish customers have AMM meters and receive electricity bills based on real monthly consumption while AMM meters were soon to be implemented in Finland at the time of interviews. When discussing customers questions regarding everyday energy consumption there were no distinct differences between the countries. A vague difference could be that the Finnish agents were more focused on how personal behaviors and habits affect consumption, while Swedish agents were more focused on different heating systems in houses and outdoor temperature. This could be a result from customers noticing a change in the price of their bill during the winter months. If the everyday behavior would be the same during the whole year that could be seen as a base consumption while changes in outdoor temperature and daylight would contribute to changes in consumption. Customers notice changes in the bill. However, changing behavior and there by the base consumption is something that can be accomplished, which naturally is not the case with outdoor temperature. A clear fact is also that the Finnish agents have a lot of sorting out and explaining to do before the customers are clear on the size of their consumption. Swedish customers, on the other hand, get information about their exact consumption per month and the agents can start the discussions from there.

Based on the discussions regarding power outages it seems like Finnish customers have a lower tolerance towards disruptions in the electricity delivery and especially the duration of disruptions. This could be from the fact that there is a higher level of automation in the Finnish grid and Finnish people are used to a continuous electricity delivery and fast recovery.

#### 4.5. Reflections from the interviews

One interesting fact clearly appearing from the statistics and conversations with the CIS agents is the number of people calling to check things up. There is a great need for being

assured that bills actually have been paid, what is going on in the power grid regarding service work, disturbances in power delivery and often just to find out what is going on inside of Fortum and with the electricity grid.

According to conversations made with CIGS personnel, the fact that the electricity grid is a system that previously was owned by the government and many people see electricity as a civil right collides with the fact that there is a free electricity market today. Grid areas, concession areas, are often, but not exclusively, owned by competitive companies. In some extent it can still be seen to be a civil right, since grid owners can't deny connection of private households. On the other hand the grid owner is allowed to charge the customer to cover the construction costs, as long as the cost is adequate. However, customers are often curious about how the grid is built and call in to find out if service work is going on within the grid.

Customers are often reporting problems and areas that, they consider, is in need of service and updating. They are also often interested in providing information on where new houses are planned and how it would be profitable to plan for new grid. This is information that could be valuable to the grid owner and could, to some extent, be utilized for long term planning. But a system for collecting this information is needed.

#### 4.6. Continuous gathering of information

Some data on incoming customer contact to Fortum was available for analyzing and the interviews with CIS were very valuable for this thesis. Some of the agents stories agreed very well with the pre study but it also gave hints on other areas of interest that does not seem to be paid attention to in the interaction with customers. Fortums CIS agents know the customers very well and there are a lot of questions and statements made repeatedly by customers.

There are still a lot of statistics that could be collected from departments handling customer contact, in order to find interesting problem areas and areas of interest to the customers. Analyzing the amount of incoming calls within different areas would give a fast

indication on how grid and business development is affecting the customers. Statistics can be used to analyze the size of problems and interests while interviewing staff is a good way of sorting out what the calls within specific areas really seems to be about.

As a result of this thesis will be databases for collecting information at the CIGS department. One database will handle power quality complaints and store at least information on how many complaints there are per geographical area, what kind of disturbances are reported, if the problem located was in Fortums grid or at customer premises and some general information about the customers electric installation. Another database will be made to handle incoming calls to CIGS regarding more technical matters. In addition to this a suggestion to a development of the categories will be made to CIS Sweden.

Statistical numbers of reactions of customers could be used within development of several departments within Fortum.

## 5. SMART HOUSE FUNCTIONALITY

Smart house technology presents an efficient and convenient way for the end-user to combine energy efficiency and every day convenience by connecting in-house appliances to an intelligent control system. (Leeds 2009) End-users could monitor and optimize energy consumption while utility companies would face the possibility of controlling or encourage the end-user to control their load distribution during the day. Further grid owners would get a chance to improve knowledge about customers load profiles, which would have a positive impact on network planning. (EEGI 2009:25) To employ this in the most optimal and functional way different technologies must interact and be developed with this in mind. Like R. Brown says in his article on the impact of smart grid on distribution system design; *"Technology should not be used for its own sake, but to enhance the ability of the distribution system to address the changing needs of utilities and their customers."* (Brown 2008)

By use of home automation and EMS services within a house, DER can be run in their most beneficial way. The smart house can be controlled separately to function in an optimized way with respect to end-users energy usage and requirements for comfort. However, this would be achieved without considering how it would affect the distribution grid and the overall energy access in the electricity supply system. By allowing interaction between smart houses and the electricity grid, both parts could be optimized for a cooperated operation. This would be more effective than allowing these two systems to run independent from each other in separately optimized operations.

With development of new trading strategies towards end-users and by adding a control plane to the electricity grid that handles the typical issues of the future grid caused by local power generation and changed power usage patterns, including excess strain on the distribution grid caused by loading of electrical cars, can be managed. Figure 13 shows the architecture of the control plane. (Verschueren and Wouter 2010)

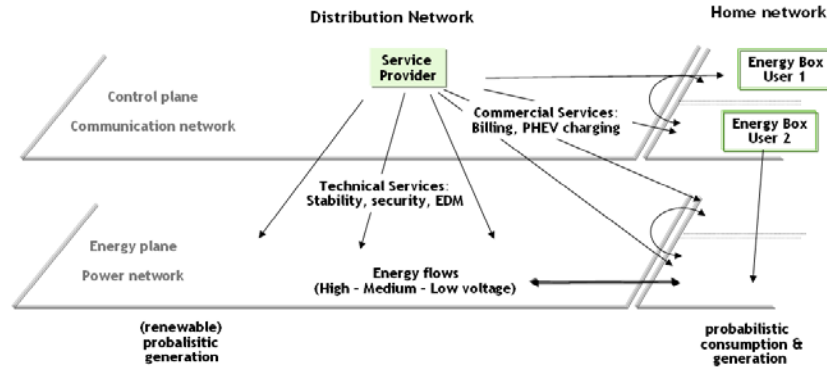

**Figure 13.** Control plane and energy plane for emerging end-user services. (Verschueren and Wouter 2010)

The type of smart house considered in this thesis is displayed in Figure 14. Energy is produced in solar panels and stored in the EV, and an EMS optimize functionality of home appliances, display data, like energy consumption at device level plus additional service information on a central display which allows interaction. The EMS optimizes energy use by controlling appliances according to a network signal, based on energy access in the local distribution grid and/or the price for electricity. Plus support for remote control functionality by use of mobile media units. This is not a newly produced house, originally planned to be used with all new technology solutions, but a typical Nordic house with heating systems and some home appliances connected to the EMS, according to end-user interest.

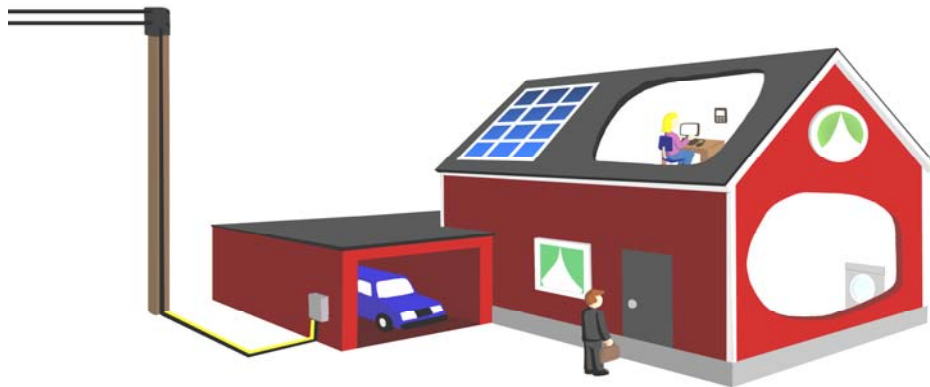

**Figure 14.** A Smart House with active DER functionality. Picture by Robert Södergård, Fortum, CIGS.

## 5.1. Interaction

By use of upgradeable and modifiable, interactive user interfaces the opportunity of exchanging different kind of information with the end-user is revealed. The information could be of various types and concern everything from energy consumption, power demand situation and different types of security systems to receiving service information from local stores and establishments.

### 5.1.1. Exchange of power demand information

By creating a system for information exchange between end-users and external actors like grid owners, aggregators and electricity retailers the end-user can take advantage of information regarding the power demand situation to control home appliances accordingly and achieve an advanced demand response functionality. In addition to this the end-users can be given detailed information on their energy consumption. (Verschueren and Wouter 2010)

Price signals are mentioned as a way to manage peak shaving and this is a good way of dealing with the general problem on a national level. However, this will not help with difficult loading or surplus situations on a local level, in the distribution grid. In order to deal with these situations, ICT is suggested. Providing the end-user with a network signal informing the end-user EMS of current grid situation would enable the end-user systems to control DER in an appropriate way. This would enable the end-user to contribute to a better electricity supply in the local distribution grid and improved power quality. The signal could just be an information signal. Accordingly, that would be mainly on ideological terms and not an economy based decision. End-users seem to respond better to price signals and a dynamic network tariff could be a better incentive for end-user contribution.

Through the same system the grid owner would be able to affect and to some extent keep track of what happens at the end-users premises as well. By introducing active user interfaces the smart grid functionalities can interact with smart house functionalities and all resources can be fully utilized and optimized. Access to detailed end-users load data,

knowledge on customer behavior and how the active resources are actually utilized, in real time, is highly useful for a new active network design and management.

Verschueren and Wouter (2010) explains that, by employing an integrated ICT network these resources, distributed generation and flexible loads could be handled in a way that benefits both the grid owner and the end-user. "*The ICT network and services provide a complete, real-time control of energy consumption and production in the power grid*". This technology enables for usage of advanced DR functions resulting in peak shaving and load flattening but also further additional DR services. (Verschueren and Wouter 2010)

For this to be optimal and effective the control system needs to be able of interacting on several different levels; device level, house level, low voltage level and aggregator level as shown in Figure 15. The higher control levels uses information from, and sends control signals to, the lower levels. This provides a ground for stability control algorithms at higher levels and support for optimization services at lower levels. (Ibid)

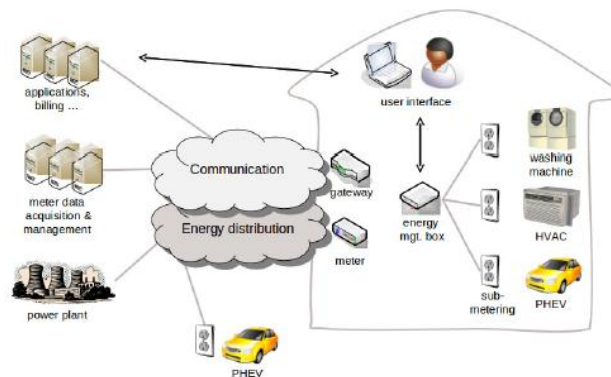

**Figure 15.** The figure shows a suggestion for architecture for smart end-users services in the power grid. The distribution network delivering energy, a communication network sending information to different parts of the system and an EMS handling energy and information signals within the house. (Verschueren and Wouter 2010)

### 5.1.2. Demand response

One way of realizing DR can be by linking the wholesale cost of electricity to the retail price, price based DR. The end-user could have a real-time price with a real-time price signal directly based on the electricity market price or a simpler type of pricing structure, time-of-use, where the retail price varies in a preset way during the day. (Abrate and Benintendi 2009) DR actions can be realized manually by the end-user or automatically by an automation system. Strömbäck et al. points out that home automation provides for two important values in DR programs, amount of load shifted and speed. With automation load can be shifted in minutes or seconds and even without the end-user having to act or even notice it happening. (Strömbäck et al. 2010)

DR is often thought of as a way of lowering energy demand during given periods of time, DR could be used to compensate high or low voltage levels in the distribution grid caused by stochastic DG. However, that might not be the only usage area of DR. If DR at customer premises is realised through usage of automation systems and scheduled operation of chosen appliances this could also be further utilized for more functionality. Masoum (2010) discuss the fact that peak power load is not the only problem in distribution systems. The same system could be used to schedule operation of harmonic rich loads like EV charging, home appliances like washing machines and industrial devices. All of these contribute to harmonic losses in distribution transformers. Scheduling the use of harmonic rich devices to avoid times of peaks in harmonic distortion could improve power quality, prolong lifetime of transformers and avoid premature failure. Masoum (2010) considers use of derating *K-Factors* with a harmonic load flow algorithm, used to evaluate the harmonic stress at distribution transformers serving nonlinear loads. This is an area that could be interesting to further investigation since it would further employ the usage of optimization systems at end-user premises. (Masoum 2010)

Everyday communication could be handled by a separate operator (utility or third party) and communicated to the end-user home gateway through a regular home modem. This information exchange could be utilized for communicating with the end-user on everyday regular non-critical demand response actions, remote control of home appliances and



several side services. This function could notify the end-user about upcoming power peaking situations, for example based on outdoor temperatures, power load situation at the moment and previous statistics; a preventive DR functionality in order to avoid critical loading situations.

Allowing a specialized actor to manage every day, non-critical commercial DR allows for a good development of the service towards end-users and the DGO. Creating flexible added value functionality is crucial in means of end-user adoption. The functionality must be changed according to end-user response in order to build a long lasting, added value functionality. Several added functionalities could be embedded in the commercial DR functionality, all according to end-user functionality demand which would vary a lot between different places, building types and customer types.

DR functionality to handle critical loading situations should perhaps be handled by the DGO in a more robust way. Disconnecting end-users in order to avoid extensive grid damage is a valuable functionality provided by smart grid technology that would shorten or avoid long outage times and repair work. Totally disconnecting all end-users in areas of the local distribution grid is one dramatic possibility. End-users could be resistive towards the idea of total disconnection. However, disconnecting end-users in order to prevent extensive grid damage would still be in the interest of end-users in order to shorten or avoid long outage times.

Mentioned in literature is also the possibility of disconnecting the main part of the end-users while allowing supply to a few chosen societal building. Which buildings to supply would be chosen by the society and not a decision of the DSO. This solution would limit the restrain on transformers at critical situations, while still allowing certain community services to function. (Energimyndigheten 2011) A further development of this would be allowing buildings with home automation systems a fixed, limited amount of power. The end-use, or the end-user EMS, would control which appliances to prioritize at customer premises. This type of functionality would provide electricity for end-users without overloading the grid and the end-user would be in control of the personal in-house electricity

system. A third alternative would be alternating the electricity supply inside a micro grid with a critical loading situation.

## 5.2. Home automation

*"Through remote controllers in appliances, which can communicate with each other and/or react to outside information, such as electricity pricing signals for example, the price responsiveness of a house will approximately double. This is called automation."* (Strömbäck et al. 2010)

Energy conservation is often mistaken with lowering energy consumption in a limiting way, resulting in a lowered comfort to end-users. Allowing appliances to run only for as long as necessary and in an optimized way is a large part of energy conservation, after optimizing DER functionality. Using a home automation system, EMS, for controlling in house appliances provides for energy conservation functionality without extra effort from the end-user, plus additionally adding a high level of comfort to the end-user. Naturally, this also adds to the price. Currently for a smart house, automation system will cost about 2000 € In residential housing, with high consumption, this expense will be saved up, especially if a dynamic pricing system is available. (Strömbäck et al. 2010)

Lewis mentions how the systems support each other: *"It seems now inevitable, as supported in general by those interviewed for this research, that without smart grid (micro generation, smart cars, sell back etc.), the added value of the smart home is far less appealing to customers. Likewise, without the in home communication and automation infrastructure, the smart grid will not present a service to/within the home"*. (Lewis 2010)

Strömbäck et al. compares energy efficiency in DR programs without automation to those with automation. The programs using automation has been seen to improve the results with 40-50% from the programs not using automation, depending on type of automation system used. This is displayed in Figure 16. Notice that the picture shows an increase in price responsiveness, not lowered net consumption. (Strömbäck et al. 2010)

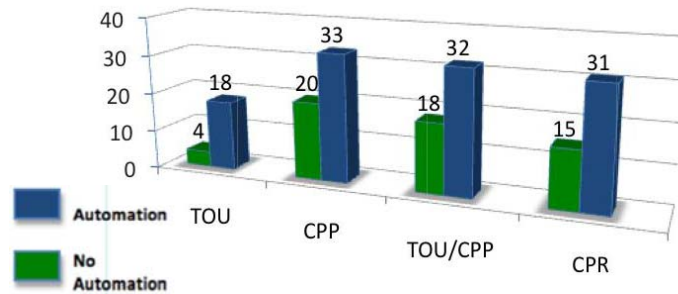

**Figure 16.** The figure shows a % of consumption reduction during peak hours (Ström-  
bäck et al 2010)

### 5.2.1. Supportive device

Even if a central display would be used as the main interface towards end-users, supportive devices doesn't have to be excluded. There are a variety of devices that could give end-users an indication of their current energy consumption situation.

One way of giving an indication of the current energy consumption and/or demand response situation that end-users can perceive easily are different kinds of ambient informative devices. These devices can be shaped in a diversity of ways and embedded in a number of devices. They can be part of home decoration and serve as a constant reminder to the users that their own habits contribute to their consumption. This is an effective feedback channel in an everyday part of end-users lives.

The basic concept of these devices is that the device, all of it or some part of it, changes color according to ones level of energy consumption and/or demand response situation. One fast glance at these devices gives the end-user a clear picture of the situation. The device gives a subliminal message to end-users that they are capable of changing their consumption pattern. This type of feedback can be appreciated by family members who don't like the displays showing a lot of information at the same time.

A good side of ambient signal devices are that the system doesn't depend on family members' ability to communicate with each other, as is with informing end-users via sms or emails. An ambient signal one day prior to a DR event can alert all members of the

family, while a message given to one family member can easily be forgotten to the next day.

There is almost no limit to how these devices could be shaped and used. Some examples of already existing ambient devices are decorative bulbs are *the energy orb* from PG&E (Figure 17), *the energy tree* by interactive Institute in Sweden and different kinds of clocks where a pattern is left according to consumed energy during the past time period. The illuminated devices don't have to show total energy consumption of the home but can also just indicate a device being turned on and the color could be changed according to level of consumption for the device. An example of this is illuminated electrical cords (Figure 18). Additional free-standing energy displays can be used to complement the central, main display.



**Figure 17.** The energy Orb from PG&E. (Greenupgrader 2008)



**Figure 18.** An illuminated electrical cord by The Interactive Institute, Sweden makes the users aware of their consumption. (Mynewsdesk 2006)

The fact that supplying end-users with information about their energy consumption in different ways and places in their homes has a positive effect on making them more aware on their personal energy consumption is confirmed by research done by Swedish Elforsk. In their research apartments in multi-family houses were equipped with two different displays, the Energy aware clock shown in Figure 19 and an ordinary display with bar-diagrams showing total consumption and multiple time resolutions. The result from this research says that the inhabitants preferred using both displays since they felt that the different ways of displaying the data complemented each other in a convenient way. (Bartush 2009)



**Figure 19.** The Energy Aware Clock from The Interactive Institute in Sweden (Mynewsdesk 2010)

Other home control devices could also be added to the smart home system, in order to provide for functionality and to give the user a feeling of control. An example of this is home/away buttons and functionality that could be carried separately or imbedded in other devices like a mobile phone. This would make it easy for the users to achieve additional energy efficiency.

### 5.3. Service structure

In order to further suggest and explain smart grid functionality a service structure suggested in Verschueren and Wouter (2010) and functionality around that is discussed. (Verschueren and Wouter 2010)

The AMM meter could act as a gateway by enabling grid owners to communicate directly with the end-users home area network (HAN). On a fully realized smart grid the end-user should be able to rely on a home energy management system (EMS) to make most of the usage decisions regarding larger appliances, PHEVs, DG and storing energy. (Smart grid 2010) Although the grid owners own the electricity meters and have access to the data today it is still not 100 % sure that the AMM meter will become the real gateway to the end-users home. Third party players have a possibility to win the hearts and minds of end-users since consumption data as well could be retrieved after the AMM meter.

Meter read data could be provided by the AMM meter, to the home management system and to the utility. In that way accurate hourly measurements are always available in the home. At the same time the AMM meter structure and capacity does not limit functionality of demand response functions and additional services. Further the AMM meter could have an overriding demand response function. This function could override the home management system and would be used only at critical load situations, preventing severe damage to the power grid. Since utility companies have a variety of different customers the communications structure could be slightly different for different customers.

Communication between the gateway and the smart application nodes is typically of wireless type. But, there has been a lot of discussion on which mean of communication should be used in outgoing communication from the end-users home gateway system. A regular home modem connection is mentioned in literature as a good approach. Questions like what happens if the end-user happens to turn of the modem when leaving the home or at night-time and how end-users should be disconnected are raised around this solution. Communicating critical DR through the AMM meter is one possibility to keep the demand-response function available to DGO's at all times and especially to be certain that the function is available at extreme, critical situations. Extreme power load situations for example at the coldest days of the year can cause devastating damage to the power grid that is followed by a time consuming repair work. According to interviews with CIS agents, most end-users would rather turn down their load than be without electricity supply for longer periods of repair work. An active demand response function could deal with these situations.

Figure 20 shows the components of the smart grid architecture simulated in Verschueren and Wouter (2010).

The simulation is an example of how a Home EMS could communicate with external service providers and the DGO, by simultaneously using information communicated through the public communication network and the AMM meter. (Verschueren and Wouter 2010)

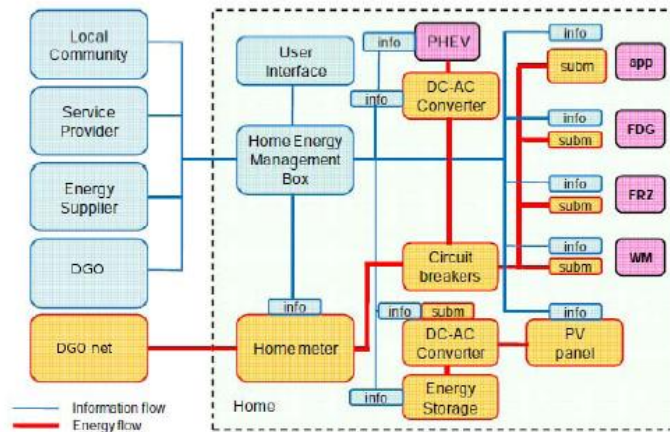

**Figure 20.** High level component architecture. (Ibid)

In their example of a smart house, residential appliances like the refrigerator (FDG), the freezer (FRZ) and the washing machine (WM) are connected through circuit breakers to the DGO net. The total energy consumption is measured by the AMM meter and some of the appliances are also monitored by sub meters. The Home Energy Management Box is the centralized component in the in-house EMS. It houses intelligent applications that control and communicate with the local appliances. By using an external communication link it communicates with remote systems of the DGO and other service providers.

#### 5.4. User interfaces

The in-house display plays a major role in making consumers more aware, and thereby stimulating a change in their energy consumption. Information such as real-time con-

sumption costs or comparisons with similar profile houses can be provided through an end-user GUI. This GUI can be made available using different media, such as an interactive touch screen, digital TV, PC or a mobile device. (Verschueren and Wouter 2010)

If a specialized service provider is allowed to manage the home energy box additional services can be provided. Energy data can be presented to the end-user in numerous ways and it could be combined with various types of additional information within several areas. An interactive user interface could also be utilized for collecting information from the user, both in an automated way and by actual interaction with the end-user.

Combining functionality from several business areas is important to the end-user and gathering data from electricity retailers and the DGO is vital since the end-user only experiences the service from electricity. End-users are not initially interested in separate information regarding electricity distribution and retailing, but the combined functionality. Adding information from other local services like libraries, markets, time tables for buses or trains, opening hours for local sports arenas and similar information could be interesting to the end-user. Important is though not to clutter the display with excess information, literature point out that end-users rapidly tend to lose interest in difficult and disturbing displays. An open interface with possibility to alter the type of information shown could be vital in order to tailor the information shown on the display according to its user.

#### 5.4.1. Central display

A centrally placed interactive touch screen could be used for the major parts of everyday end-user interaction. This display could show an extended amount of information to the end-user and have support for altering what type of information is shown to the end-user. This display could also get distinct information from the DGO, retailer or other external actors on request of the end-user. This is a place for providing the end-user with explanatory information from the mentioned service providers. The information could be given in shape of informative instructions or animated instructions for example explaining the components of the electricity bill or giving instructions for problem solving.



This central display should be used to show and handle what is going on in the home. One part of the functionality is to show how much energy has been produced and consumed in the home. It could have a standard mode for showing energy consumption and other relevant real-time information. This interface could also be displayed on a PC on a portable interactive touch display.

#### 5.4.2. Mobile media units

Previous has been handled the fact that usage of internet services and mobile devices is increasing rapidly in all age groups. Smart house functionality could be extended by providing applications for mobile media units. The functionality should be limited due to a limited screen size. This is also an area for customizing user applications according to end-user interest and type of house and automation system.

These applications could display a limited version of the in-house display and would provide additional comfort in remote information and control action. By usage of different mobile units the end-user would not be limited to controlling their homes from inside the home or from a fixed internet connection.

#### 5.4.3. Communication of service information

When looking at the analyze of incoming customer contact to Fortum and the interviews with CIS agent it is apparent that Fortums customers are curious regarding what is happening with the electricity grid, the electricity market and also within Fortum. The customer interaction investigation could be used as base material when developing customer interaction platforms and at the same time accustoming customer to the idea of interacting with the electricity company.

The largest parts are contacts concerning moving, invoicing - payment and complementing information for invoicing. This is functionality that could be automated and to some extent already is through Fortums webpage. Fortums webpage aligns quite well these categories. The problem with a web page is generally that it is takes too much involvement from the customers to start using it and creating a user profile. A central user interface in

the customers' home could be well suited to help with these functionalities. Especially in rental apartments the moving process could be automated through a central interactive interface. Through which information about invoicing and agreements and additional services also could be exchanged with the DGO, electricity retailers and other services related to energy consumption plus numerous additional service providers.

The operator of the daily service could also provide the end-user with information on ongoing repair-work in the electricity grid. According to the interviews with the customer service agents, end-users are often curious about what happens during power outages and will often repeatedly return to the call-centre to get updates on the situation. With a small backup power keeping updated communication going through power outages the end-user would be assured that service work is ongoing and progressing. This would build end-user trust and contribute to the important feeling of empowerment. The user interfaces could be used to carry out several different types of service interactions.

#### 5.4.4. End-user awareness through knowledge

Displaying the end-users consumption distributed between different types of loads and, in case of a connected DG-unit, production and perhaps energy stored in energy storages on the interface would give the end-user a feeling of being in control of what is going in the residential electricity installation. This information would give the end-user insight in how much energy is spent on different devices or energy consuming services. In other words, information on how energy is used when and where. This would be base information for the end-user to decide upon, how much the end-user actually is willing to pay for different energy services or actions in the shape of energy consumption. In the interviews with CIS it was also apparent that the public cannot relate their energy-usage habits to total consumption. Displaying device level consumption to some extent, would give the end-user insight in their consumption patterns and habits without demanding a high level of involvement from the end-user. Providing the end-users with a device level historical view on their energy consumption would also give them the possibility of discovering deviations in energy consumption of different devices. There by faults and need for service would be discovered in time.

Communicating information from Fortum would also give the end-user a feeling of control concerning what happens in the interaction with Fortum, 'real-time' information on paid bills etc. This is also a way of accustoming the end-users to the interaction with electricity companies.

#### 5.5. Parallels to Rogers model of diffusion

To sum this up, when smart grid and smart house technology is communicated it should replace a previous lacking system or give some kind of additional advantage which could be economical or provide comfort or be satisfactory in some other way. It should also be compatible with social norms and valuations.

Interactive user interfaces can be used to increase the observability, mobile units would also increase this characteristic. However, the functionality of the user interfaces must also match Rogers' model and the complexity level must be remembered. Interactive functions and customer interaction through the user interface can add to the real advantage characteristics since interaction with service providers is simplified.

Energy storages at end-user premises and DG units also add to the observability category. They can be shown to others and DG units seen from the outside, informing others that the owner has adopted the innovation. Consequently, information concerning produced, and sold, electricity can be displayed on a graphical user-interface to raise the observability level and add to the trailability level when the end-user is able to experiment with different layouts and time scales.

Displaying energy consumption on device level adds to the observability level and the trailability level. This can also raise the 'real advantage' since the amount of electricity consumed can be seen per appliance or as a total of a group of appliances. This allows the end-user to actually see how much electricity is consumed per appliance or group of appliances, per activity, and the end-user can decide based on that how much is considered acceptable to pay per activity.

Load control is a functionality that could collide with the compatibility characteristic. Allowing outside actors to control in-house appliances might not be found desirable since it clashes with the norms of society. People are accustomed to a stochastic consumption behavior and a production system that adjusts production according to consumed amount of electricity. In this matter it is essential how the service is modeled and described to end-users. There is a huge difference in the idea of allowing an external actor, such as DGO's, control of end-user devices compared to allowing the end-user to control their devices according to local energy demand. Disconnecting loads at critical situations would be a real advantage in shortened service time. Development of a commercial DR functionality would allow end-users to operate their appliances in an economical manner and avoid extensive grid expansion. This service could be grouped with other end-user services in order to create a package of end-user services, providing a more obvious real-advantage.

#### 5.6. Communicating the smart grid offering

*"The scope and attractiveness of smart home and demand response will be heavily influenced by the creativity, appropriateness and availability of third party application and services. The possibility to expand the offering not only to provide the customer with the prospect of additional long-term benefits, but will be a key element in delivering and maintaining the level of customization and benefit necessary to retain the involvement of the customer in the long-term service relationship. To this end the quality and diversity of partnership will be an essential element in the successful development of smart home and demand response. An open architecture will also be essential."* (Lewis 2010)

One of the categories included in the model of diffusion is that the innovation must have a relative advantage. People have different triggers that make them feel good and content in some way. An innovation that triggers those feelings can be experienced like an advantage in life. To make the smart grid and smart house technology an advantage we can look at how people want to feel and which needs they have. Since that is one focus area

of this thesis and indications of that are looked for in the interviews with the customer service agents. These things are also mentioned in literature.

Philip Lewis writes: "*Customers want to feel good. They want to feel comfortable, stress-less, good about the way they see themselves and good about the way they look to others. This need to feel good therefore manifests itself in a number of opportunities for smart homes and demand response to fulfill such customer needs through, Peace of mind, clean life style-fit, feel good citizen, cleaner place to live, makes me cool, my beautiful home, entertain me, family fun and convenience. These nine customer benefits should once again not be aggregated into one or a vague set of messages, but rather developed by utilities into specific services and communications within the broader offering.*" (Lewis 2010)

The customer benefits should be communicated to end-users to display advantages of smart house and smart grid technology. Since different end-users have different levels of involvement different type of information can be given to different society groups. In connection to Smart Grid and Smart house technology energy and efficiency have often been mentioned as the primary benefits. But it is also discussed that these benefits does not give big enough economical advantage compared to the effort to get involved and the cost of the installation.

Regarding environmental considerations Philip Lewis divides the customers into three equally big groups; customers that will not be swayed by an environmental message, those who will be significantly influenced and those who would take an environmental message just as a supplementary benefit. Even if one third of the customer is a substantial number there is also some distance between being influenced and actually being inspired enough and having the finances to take action. Even if the end-user has an involvement by opinion and an involvement in the subject, economical considerations might cause the decision based involvement to stop at the intention. Environment oriented purchases of smart home and energy management solutions are therefore only likely to represent a few percent of the utility customer base. When allowing environmental issues to be part of the communicated offering it will be a strong contributor. Energy efficiency is another part of

the offering which is closely connected to the environmental aspect. Philip Lewis emphasizes the importance of communicating several aspects as separate benefits which will develop the offering into a completely different innovation towards the end-users. These benefits are enabled by creating functionality. (Lewis 2010)

Providing information to the end-user is a strong contributor to enabling the end-users feeling of empowerment. Information that might not be seen as valuable to the utility company can be very interesting to end-users and vice versa. This might be an area where end-user segmentation could be valuable or giving the end-user possibility to choose which information to receive.

Lewis continues; *"One of the main reasons why customers switch energy supplier is because they can."* This doesn't always mean that the customer is dissatisfied with the service provided by the energy supplier. Lewis explains that customers often feel that they would like more control over the prices they pay, the size of their energy bill. (Ibid)

According to the interviews with the customer service agents conducted for this research customers feel trapped by the grid owner also and often expect to turn over all of their business to the new utility company when they switch electricity retailer. Since the end-users houses are physically connected to the distribution grid this is apparently not possible. Smart technology can give the end-user the feeling of empowerment without necessarily switching energy supplier. This could be done by providing the customer with adequate information. From a marketing point of view demand response and smart house technology is very important as a way of developing a partnership with the energy customer and giving them the feeling of empowerment without switching energy supplier. (Lewis 2010)

Finally it should not be forgotten that technology development by itself is also a main driver in the smart grid development. This can also be seen as an advantage to be communicated to end-users. (Leeds 2009; Cleen 009)

## 6. CONCLUSIONS

Some functionality basics of smart grid and smart house technology have been presented. How the public relate to energy, energy consumption and innovations has also been handled. Additionally problem areas and areas of interest to customers of an electricity company have been investigated. All of this resulted in a collection of smart house functionality, presented in chapter 5 that agrees with the literature study on smart technology and customer behavior plus the interviews with CIS agents. This is a collection of functionality that would provide a good base for development of long term, added value services towards end-users.

Coordination of services is one of the future challenges. Electricity customers are generally not aware of how the electricity supply system functions and are not interested in information given from different actors regarding the same service. The free electricity market separated grid services from electricity retailing and in practice this has resulted in two separate electricity bills to the customers. Combining information from separate actors is also an important issue when planning interactive user interfaces and other feedback systems and practices. End-users experience one service and consequently, expect one, combined feedback system.

Smart grid acceptance is repeatedly discussed and this thesis presented Rogers' model to be used when communicating and modeling the offering of smart grid to end-users. Whether an innovation is adopted by the public is determined by how the end-user experiences the innovation and is e.g. based on the end-users previous knowledge, experiences and norms and valuations in society. The fact that the innovation of smart grid is different towards all the different actors in the electricity supply system should be remembered when communicating the offering of smart technology. Implementing smart grids also contribute a large change to and have to be accepted by the electricity industry as a whole. A lot of technology advancements have already been made and the new technology must also be trusted and accepted.

Technology solutions for smart grid and smart house functionality are continuously researched and further developed. This should be coordinated with further research on functionality towards and interest of the end-users. One way of doing that is continuous gathering of customer response to customer service departments. Additionally market research companies could provide response from customer groups well distributed between different customer groups in age, geographical areas and level of knowledge and so on.

From the investigation on customer behavior it can be concluded that the public generally has a low involvement in and knowledge about energy consumption. From the interviews with CIS it can be seen that the AMM meters have improved Swedish electricity customers knowledge on their monthly consumption. When comparing the answers from CIS Finland to the answers from CIS Sweden it is apparent that monthly real-values on energy consumption are a good base for energy related discussions with customers. However, end-users are in most cases not able to relate their personal habits and other influencing factors to a total consumption. Providing an additional device level consumption data to some extent, would be preferable. Historical device level consumption data would also give a good insight to the end-user on energy related occurrences in their homes. Based on this data people could decide how much they are willing to pay for certain services and take energy conservation decisions based on real data. Collecting end-user data would also be a good base for future scientific network planning, based on real values and not assumptions and coefficients.

The word smart grid is often used in discussions regarding grid development. Separating smart grid development from other grid development is important. The Swedish energy inspectorate (EI 2010) also mentions that lack of knowledge on smart grid technology and confusing it with other development of the electricity network is one barrier towards development and acceptance of smart grid within the electricity industry.

Smart house technology provides for numerous ways of optimization of DER functionality. By providing adequate information signals e.g. from the electricity grid to be incorporated in the optimizations schedules provides a possibility for a long-term development



with possibility for updated functionality and optimization. Regulation of today is often said to limit the development. Regulation is known to change from time to time and by building a system based on adequate information signals and upgradeable and modifiable systems smart house functionality can be optimized according to changes in regulation.

## REFERENCES

Abrate, G., Benintendi, D. (2009). *Measuring the potential value of demand response using historical market data*, The 6th International Conference on the European Energy Market (EEM 2009), 27-29 May 2009 Leuven Belgium.

Alfredsson B, Fortum Distribution Sweden, CIGS, Several conversations during 2010 concerning the connection process of micro and small scale DG.

Bartusch C. (2009), *Visualisering av elanvändning i flerbostadshus*, Elforsk Rapport 09:38, Final report within the Elforsk ELAN program part III, Sweden.

Brown R. (2008), *Impact of Smart Grid on distribution system design*, (2008), Power and Energy Society General Meeting – Conversion and Delivery of Electrical Energy in the 21<sup>st</sup> Century, IEEE, 20-24 July 2008.

Cluster for Energy and Environment (CLEEN) Oy, [webpage]. Helsinki: Cleen Oy. [Cited 20.11.2010] <http://www.cleen.fi>

Cluster for Energy and Environment (CLEEN) Oy, Smart Grid and Energy Market (SGEM), 2009, Proposal for Research Program, Version 8.3, 16.08.2009.

Driesen, J., Belmans, R. (2006), *Distributed generation: challenges and possible solutions*, Power Engineering Society General Meeting, Montreal, Que., IEEE.

EgenEl, [Webpage] Stockholm: EgenEl, <http://www.egenel.se> [Lefalet] Cited 15.11.2010

Energiateollisuus ry., “*Connection of micro-generation to the electricity distribution network*”, Network recommendation YA9:09, Helsinki:Energiateollisuus ry.

Energimarknadsinspektionen (EI) (2010). *Anpassning av elnäten till ett uthålligt energisystem*, Report no. EIR 201018, [Web publication], Eskilstuna: 30 November 2010, <http://www.ei.se>.

Energimyndigheten (2011), *Styrel: Stryning till prioriterade användare vid elbrist*, [Webarticle] Eskilstuna: 09.02.2011. <http://www.energimyndigheten.se/styrel> [Cited: 15.02.2011]

European Regulators Group for Electricity & Gas (ERGEG) (2009), *Position Paper on Smart Grids- An ERGEG Public consultation paper*, REF: E09-EQS-30-04, European Energy Regulators, Brussels, <http://www.energy-regulators.eu>.

Evens C., Kärkkäinen S., Pihala H (2009) *Distributed resources at customer premises*. Espoo: VTT Research, Report no. VTT-R-06411-09, Restricted Access, INCA project.

Finnish Communications Regulatory Authority (FICORA) "*Telecommunication markets in the Nordic countries.*", Published 22.06.2010, <http://www.ficora.fi>

Greenupgrader, [Webpage], [www.greenupgrader.com](http://www.greenupgrader.com), [Cited: 10.11.2010], Published: 01.04.2008.

Ikäheimo J., Evens C., Kärkkäinen (2009) *DER Aggregator Business: the Finnish Case*, Espoo: VTT Research, Report no. VTTR0696109, Restricted Access, INCA project.

Jussila S., (2010). *Use of electricity storages in smart grids*, Masters Thesis, Tampereen teknillinen yliopisto.

Kumpulainen, L. K., Kauhaniemi, K. T. (2004 a). *Analysis of impact of distributed generation on automatic reclosing*, Power Systems Conference and Exposition, 10-13 Oct. 2004 New York, IEEE Power Engineering Society.

Kumpulainen, L. K., Kauhaniemi, K. T. (2004 b). *Impact of distributed generation on the protection of distribution networks*, Eighth International conference on Developments in Power System Protection, 5-8 April 2004 Netherlands, IEEE Power Systems & Equipment Professional Network.

Lewis P. (2010) . "*Smart house vision 2010*", Helsinki, VaasaETT. [Webpublication] <http://www.vaasaett.com>

Leeds D., *The Smart Grid in 2010: Market Segments, Applications and Industry Players* (2009), GTM Research.

Lindstedt I., Mårdsjö Blume K. (2008). *Mätaren kom - Vad hände? Intervju studie om kundernas förväntan på de nya elmätarna och deras kunskaper om el och energi.*, Elforsk Rapport 08:76, The report is part of the Elforsk ELAN program, Sweden.

Masoum, M.A.S., Moses, P.S., Deilami, S. (2010). *Load management in smart grids considering harmonic distortion and transformer derating.* Innovative Smart Grid Technologies (ISGT), 19-21 January 2010, Göteborg, Sweden. Conference paper.

Mauri G., Moneta D., Bettoni C. (2009) *Energy Conservation and Smartgrids: new challenge for multimetering infrastructure.* Power Tech Conference, 28 June -2 July 2009, IEEE, Bucharest, Romania. Conference paper.

Momoh, J. A (2008) *Electric power distribution, automation, protection and control*, CRC Press Taylor & Francis group, <http://www.taylorandfrancis.com>, ISBN-13:978-0-8493-6835-6.

My newsdesk - The news exchange site (15.06.2006). [webpage] <http://www.mynewsdesk.com/se>, pressmeddelanden, [Cited: 10.11.2010].

My newsdesk - The news exchange site (07.09.2010). [webpage] <http://www.mynewsdesk.com/se>, pressmeddelanden, [Cited: 10.11.2010].

Nellevad, P., Bergsveen, A. (2010). Rapport Svenskarnas användning av telefoni och internet 2010. PTS. Rapportnummer: PTS-ER-2010:25, <http://statistik.pts.se>, "*Individundersökning*".

Norman Å, Fortum Distribution, CIGS, Several conversations during 2010 concerning power quality complaints.

Papaefthymiou, G., Houwing, M., Weijnen, M.P.C. and van der Sluis, L. (2008) *Distributed generation vs bulk power transmission*, Infrastructure systems and services: Building Networks for a Brighter Future (INFRA), 10-12 Nov. 2008, Rotterdam.

Pedrasa, M. A. (2009). *"Improved Energy Service Provision through the Intelligent Control of Distributed Energy Resources"*, IEEE Bucharest Power Tech Conference

PTS, *"Svensk Telemarknad 2009"*, Rapportnummer PTS-ER-2010:13, Published 03.06.2010, <http://statistik.pts.se>

Rogers, E.M. (2003), *Diffusion of innovation*, Fifth edition. New York: Free Press. ISBN-13: 978-0-7432-2209-9

Puttgen, H.B., MacGregor, P.r., Lambert, F.C. (2003). Distributed generation: Semantic hype or dawn of a new era?, *Power and Energy Magazine, IEEE* 1:22, Issue 1.

SEAS\_NVE, Presentation "Målerjagten", VaasaETT Conference, Berlin December 2010.

Science online. [Webpage] Cited: 15.11.2010.  
<http://www.scienceonline.co.uk/energy/renewable-energy.html>

Statistics Finland (2008). 2007, Table 4: Supplies and Total Consumption of Electricity 1990-2007 (Excel), [Webpage] Helsinki: Statistics Finland [Cited 20.11.2010]  
[http://www.stat.fi/til/ekul/tau\\_en.html](http://www.stat.fi/til/ekul/tau_en.html)

Statistics Finland (2010). *Every second Finn uses internet several times a day*, [Webpage] Helsinki: Statistics Finland. Published 26.10.2010. [Cited 20.11.2010]  
[http://www.stat.fi/til/sutivi/2010/sutivi\\_2010\\_2010-10-26\\_fi.pdf](http://www.stat.fi/til/sutivi/2010/sutivi_2010_2010-10-26_fi.pdf)

Strömbäck J., Dromaque C., Golubkina D (2010). *"Demand response pilot comparison"*, Helsinki, VaasaETT. <http://www.vaasaett.com>

Sundberg, S., Carlsson, J., Ström, L., Johansson, T. (2010). *Nettodebitering - Förslag till nya regler för elanvändning med egen elproduktion*, Eskilstuna: Energimarknadsinspektionen. Publication no. EIR2010:23 <http://EI.se>

The European Electricity Grid Initiative (EEGI), *The European Electricity Grid Initiative (EEGI): a joint TSO-DSO contribution to the European Industrial Initiative (EII) on Electricity Networks (2009)*. Florence workshop.

Verschueren, T., Wouter H.(2010). "*Architectures for smart end-user services in the power grid*", IEEE/IFIP Network Operation and Management Synopsium Workshops.

Yanpeng, W. (2009). *Scientific management - the first step of building energy efficiency*, Information management, innovation management and industrial engineering, Xi'an, China, IEEE, 26-27 December. Conference paper.

Yingyuan Z., Meiqin M. (2008). *Study of Energy Management System for Distributed Generation Systems*, Electric utility deregulation and restricting and power technologies, Nanjing China, 6-9 April 2008, Conference paper.

## APPENDIXES

## Appendix 1: Base material for CIS interviews

- Questions based on the statistics
  1. Forced contact
    - Payment
    - Moving
    - Agreements
    - Invoicing
  2. Investigative contact
    - Electricity prices and supplier
    - Explaining costs
    - Consumption, high bill
    - Questions electric installation
    - Delivery disturbances
  3. Others
    - General moving question
    - Confirmation
    - Larger customers
- Questions regarding electricity consumption
  1. Usual questions
  2. Knowledge level
  3. Ability to accept new information
- Questions regarding end-user knowledge
  1. Energy consumption
  2. Generally regarding the electric installation
- Smart Grid related questions
  1. Residential electricity production
  2. Energy displays
  3. AMM meters
  4. Load control (Day and night tariffs)
  5. Locally produced electricity

## Appendix 2: Answers from CIS interviews Sweden

<b>statistik, handläggare frågade</b>	<b>nr</b>	<b>svar från CIS handläggare</b>
Flytt	6	Kunden tycker det är krångligt med mycket info som behövs
	7	5 vet inte om att de ska anmäla det
	1	borde va bättre info till kunden om vad som/att det ska anmälas
	1	Kunden tycker att vi borde ha på vem som flyttar vart
	13	
Avtal	2	för många olika priser att välja mellan
	3	2 är det akutella priset ett bra pris
	1	har man inget internet måste man ringa runt och kolla
	1	för många olika bolag att välja mellan
	6	
23-levbyte	2	frågar hur det går till, hur man gör
	2	1 lite samma som 42 - nätpriser
	3	
Tariff	1	varför byta tariff?
	4	1 lönas tidstariff?
	1	mest lägenhetskunder som byter
	1	frågar varför de har sin säkring
	4	
3-betalstatus	3	vill bara kolla upp så att det faktist har blivit betalat
	4	1 vill ha muntlig kontakt
	4	
Förbrukning - hög faktura	6	mest vanligt på vintern
	2	varför olika för brukning i samma period, olika år
	6	2 jämför med grannar/bekanta trots olik hustyp/uppvärmning
	5	kollar priset först, sen förbrukning
	1	inte medvetna om att de är deras egna vanor som orsakar hög förbrukning
	1	räknar om till årsförbrukning
	2	ifrågasätter mätarn, man tror inte på att man förbrukar så mycket
	1	nyinflyttad i hus lägre koll, lägenhets kund lägre koll
	2	förväxlad mätare, vilket händer sig
	1	nån som plötsligt en dag börjar se på fakturan



	3	en del kan ta emot info
	26	
8- allmän förbrukningsfråga	1	vill lära sig hur man kan sänka sin förbrukning
	1	vill veta hur mycket olika förändringar påverkar
	5	2 frågar hur mycket olika appliances drar
	1	vill ha vägledning
	5	
12 - fakturaadress, 2	2	adressen är kopplad till där man är skriven, fakturan åker fel,
14 - förklaring nätkostnader, 2	1	förstår inte varför de får fler fakturor när de bytt elleverantör
	1	vill få fakturan förklarad
6 - våra priser	2	hur tror du priset kommer att utvecklas
	4	1 stor skillnad på prismedvetenhet
	1	vill bara ha och inte välja
	2	vad vi har för priser
	2	vill ha rabatt/föhandla till sig bättrepris
	1	kan ofta kopplas till förbrukning
	9	
10 - avtalsstatus, 1	1	frågar vilket elavtal de har
16- anl.uppgifter	1	har koll på priser och tariffer
	6	4 anl. Id eller säkring
	1	var elskåpet sitter
	6	
27 säkringsfrågor	1	om de kan säkra upp
	2	1 vill veta hur de gör för att ändra
20/22 - driftstörningar	1	många felringningar
	1	vi har bra info att ge till kunderna
	7	6 Vill veta VAD som sker, vilka åtgärden görs
	2	vill bara kolla upp
	2	vill veta sluttid
	1	ringer fler gånger för att kolla
	1	vill veta vad vi planerar
	2	oftast vänliga och accepterar
	4	ofta kunden som informerar oss
	3	kunden är mer nöjd och lugn när de märker att vi har koll på vad som sker
	2	kunden är ofta överraskad över att vi inte har bättre koll

- beroende på område hur de reagerar på avbrott, olika förståelse
- 4 se
- 3 aviserat mer irriterande, då det fortfarande kan påverkas
- 32

---

<b>Förbrukning</b>	1 byter elbolag istället för att sänka förbrukning
15 handläggare har konsulterats	2 kollar om de kan sänka huvudsäkring vid högt pris
ang. resten av frågorna	1 byter avtal
	jämför förbrukningen med tidigare år, reagerar endast på skillnader
	4 nader
	8 vill veta VAR förbrukningen skett
	1 vill veta varför deras förbrukning ser ut så som den gör
	1 inte medveten alls om sin förbrukning
	4 kan oftast ta till sig info
	1 skyller hög förbrukning på mätaren
	1 få tycker att vi lurar dem
	lgh kunder har svårt att förstå hur mycket el som förbrukas när de
	1 de
	flyttar till hus
	1 har koll från fakturan
	1 mest unga och medelålders som bryr sig
	5 ojämn kunskaps nivå hos kunderna
	1 större kunder har bättre koll på förbrukningen
	1 unga har bättre koll
	1 villaägare har bäst koll
	2 ofta småförbrukare som bryr sig
	2 kunden ser inte elen, svårt att bry sig
	undrar hur förbrukningen kan ändra fast de inte ändrat på något i huset
	1 lättare att prata med om de ens börjat titta på förbrukningen
<b>Kunskap hos kunden</b>	9 oftast dålig kunskap om vad som finns i huset
	2 somliga vet bra vad de har hemma och andra inte
	2 de flesta har bra koll
	3 husägare har ofta bra koll på uppvärmnings system
	1 vill ha pengar tillbaka för att de haft för hög säkring
	3 dålig koll på vad som är kundens ansvar
	1 dålig koll vad som är elektrikers och fortums ansvar
	1 ingen koll på var i huset det förbrukas

- 4 lägenhetsunder minst koll
- 5 dålig koll på vad som förbrukar hur mycket
- 6 tänker bara på att det som de ser förbrukar
- 1 alla familjemedlemmar har inte koll

- varmepumpar, förstår inte att det endast är förändring på upp-  
1 värmnings el,  
Inte totalförbrukningen

- 1 svårt med elhandel/nätkostnad
- 1 ingen åldersskillnad på kunskapsnivån
- 1 inser inte osmarta lösningar

## Smart Grid

### Hur ofta samtal?

#### egen prod

- 11 få samtal, några
- 1 många samtal
- 1 mycket frågor på mail
- 1 ringer in efter att de sett reklam om det
- 2 tror det finns många med solpanel men som är oanmälda

### Hur komma igång?

- 9 kan man använda vindkraft/solpanel
- 8 kan man sälja överskotts el
- 6 hur man ska gå tillväga
- 2 kostnader för att få igång det
- 1 vilka tillstånd som krävs
- 1 hur man säljer sin el
- 2 vad man kan tjäna på det
- 1 folk som frågar om man får avdrag på fakturan för det

### Vad är egen prod?

- 2 hur de olika sätten fungerar
- 1 vill själva få bestämma över sin el
- 1 vill köpa in sig på större vindkraftverk
- 1 Miljövänligt

### Vem frågar?

- 1 ofta barnfamiljer, runt 35 års åldern, höginkomsttagare
- 1 Entusiaster
- 1 ofta jordbrukare, folk med egen gård och stor förbrukning.

### Hur ofta?

#### miljöval

- 4 bra miljöval, sällan men sker

- 1 lite frågor om det
- 3 vill ha ja/nej svar om miljövänligt eller inte
- 2 intresse ökar
- 1 frågar sällan om det

#### **Vad frågar de?**

- 7 frågar vilken typ av produktion
- 6 frågar inte VAR
- 2 mest focus på kärnkraftverk
- 2 mest intresse för vatten och vind

#### **Vem frågar?**

- 1 kundtjänst har dålig info om vad de ska säga  
ofta samma typer som vill spara energi som också vill köpa miljövänligt
- 1 jävligt

#### **last styrning**

#### **Vad frågar de?**

- 5 vilka tider gäller det och hur fungerar
- 1 Tariffer
- 2 varför har man det
- 4 tjänar man på det
- 1 bra respons när folk förstår

#### **Hur ofta?**

- 2 inte stort intresse idag
- 1 väljs inte som ny grej  
vill oftast bort från det, både olönsamt och för att de inte förstår
- 4 står
- 1 många vet inte ens om att de har det
- 7 frågar sällan om det

#### **elmätarna**

#### **Frågor om mätaren...**

- 1 hur ofta de läses av, själv avläsningen
- 1 hur de fungerar
- 1 påverkas av media
- 2 klagar på funktioner, svart display, ska den blinka?
- 2 OM de fungerar
- 1 mätaren är ivägen och att den låter
- 1 rädsla för strålning
- 1 mest äldre som är skeptiska

#### **Hur människor reagerar på mätaren...**

- mätaren ifrågasätts, tycker att de har högre förbrukning sen
- 7 mätaren bytts

- 1 börjar jämföra med andra
- 6 ökat medvetenheten
- 1 vill veta var mätaren finns
- 1 en del folk följer förbrukningen stenhårt
- 1 tycker det är bra att kunna se
- 1 accepterar med tiden
- 1 dragit på sig skulder för att de inte förutsett högre förbrukning

#### Vidare utveckling det frågas efter...

- 1 vill kunna läsa av mätaren själva
- 3 vill ha Realtids värden
- 2 vill ha dygnsvärden
- 3 vill veta VAR i hemmet förbrukningen skett
- 2 skulle vilja ha mer info på displayen, text etc. -> energi display
- 1 har fått fråga om energidisplay
- 1 intresse för riktigt Realtidspris

#### spänningsklagomål

- 1 irriterade när vi inte har koll på elnätet
- 1 ok om vi har fel men åtgärddar
- 1 vill veta vad som händer

#### Statistics, agent consulted

Mooving

7

#### nr Answers from CIS agent

- 6 Customer finds it difficult to give all information
- 5 Are not aware that this should be announced  
Better information should be given to customers prior to  
mooving
- 1 Customers think we automatically should get information  
about them mooving
- 1
- 13

Agreements

3

- 2 Too many different tariffs to choose between
- 2 Wants to hear if their active prie is "a good one"
- 1 People without internet connection must call to ask
- 1 too many different companys to choose between
- 6

Delivery changes

2

- 2 ask how this is done/how to handle
- 1 a bit like net tariffs
- 3

Tariffs	1	why change tariff?
4	1	is time tariff profitable?
	1	mostly apartment customers asking
	1	asking why they have the fuse size they have
	4	
Payment status	3	wants to check up that they really have paid
4	1	want to hear it in person
	4	
Consumption - high bill	6	mostly wintertime and after
6	2	why different consumption during the same period, different year
	2	comparing to neighbours/friend despite different houses and heating systems
	5	checks price first, then consumption
	1	not aware that their personal habits contribute to their consumption
	1	recalculates to yearly consumption
	2	questions the meter, do not believe they have that high consumption
		recent house owners have less control, apartment customers also have less control
	1	also have less control
	2	exchanged meter, which happens
	1	suddenly starts to look at the electricity bill
	3	some can accept information
	26	
Consumption - General	1	wants to learn how to lower their consumption
5	1	want to know how different improvements/changes will affect their consumption
	2	ask how much different appliances consume
	1	want energy guidance
	5	
Billing address	2	this information is retrieved from public registers, that sometimes are not correct
2		
Explaining grid fees	1	Questions why they get two different bills after changing retailer
2	1	wants to get the bill explained
	2	
Price question	2	Asks how we think the price for electricity will change
4	1	large differences in price awareness

	1	customers do not want to make the choice
	2	asks our prices
	2	want a rebate or negotiate for a better deal
	1	can often be connected to consumption questions
	9	
Agreement status	1	asks what agreement they have at the moment
		customers know about tariffs/what they pay, nothing about
Electric installation	1	their electric installation
6	4	Asks for fuse size or id.
	1	where their main fusebox is placed
	6	
Fuse	1	if they can change to a larger fuse
2	1	how to act to change into a larger fuse
Network operation disturbance	1	many wrong numbers and accidental calls
7	1	we are provided with good information to give customers
		wants to knowe WHAT hapens, what caused it and which
	6	measures are taken
	2	just checking up
	2	wants to know when interruption ends
	1	calls several times to check up
	1	wants to know what is planned
	2	Mostly friendly and accepting
	4	often the customer who informs us of outages
		customers calmer when we know what is going on and notice
	3	that we are in control
	2	often surprised that we do not have better/more control
	4	how customers react are a lot depending on where they live,
		rural areas are more accepting
		more annoyed with announced interruptions, since the might
	3	be able to affect that
	32	
<hr/>		
<b>Consumption</b>	1	change electricity retailer instead in lowering consumption
15 agents consulted	2	check if they can lower their fuse at high prices
on the rest of the questions	1	changes electricity argeement
		compares their consumption to previous years and recats only
	4	to change sin price
	8	want to know WHERE in the house energy is consumed
	1	wants to know why they consume as much
	1	Customers are not aware of their consumption
	4	can mostly accept information

	1	blames high consumption on the meter
	1	seldom they feel we are fooling them
	1	apartment owners have a hard time to understand how much electricity is consumed in a house
	1	checks consumption from bill
	1	mostly younger and middle-age people who cares
	5	very different knowledge levels
	1	larger customers have more control
	1	younger people have more control
	1	house owners have most control
	2	often small consumers that care the most
	2	since the customer can't see the electricity it is hard to care about it
	1	wonders how consumption can change even if they haven't changed anything
	1	easier to reason with customers once they have started to check their consumption
<b>Knowledge level, customers</b>	9	low level of knowledge over what appliances the customers have
	2	some people know well what they have at home, others not
	2	most people know well
	3	houseowners know what kind of heating system they have
	1	wants money back if they have had to large fuse, bad knowledge on responsibility customer/Fortum
	3	low knowledge on what is customer responsibility
	1	low knowledge on what is the responsibility of th electrician
	1	noknowledge on where in the house electricity is consumed
	4	appart mednt customers hav least controll over consumption
	5	low knowledge on what consumes much energy
	6	only thinks of visible electricity consumption
	1	all family members do not have control
	1	heatpumps, don't understand that it lowers only usage of electricity used for heating
	1	hard to understand the difference between electricity trade and distribution costs
	1	no age difference in knowledge level
	1	do not realize electricity solutions



- Residential electricity production
- 11 just a few calls
  - 1 many calls
  - 1 many questions on e-mail
  - 1 calling in after seeing commercials
  - 2 a lot of unannounced solarpanels
- How to start?**
- 9 how to use solarpanels/vindturbines
  - 8 Wonder if they can sell excess electricity
  - 6 how to act
  - 2 if there will be extra costs
  - 1 what kinds of permission is needed
  - 1 how to sell electricity
  - 2 what can be earned from it
  - people who ask if there will be some kind of discount at the electricity bill from this
  - 1
- What is DG?**
- 2 how the different techniques work
  - 1 wants to be in charge of their own electricity access
  - 1 want to be part of a larger wind park
  - 1 environmentally friendly
- Who asks?**
- families with children, about 35 years old, high-income earner,
  - 1 not only to save
  - 1 Enthusiasts
  - 1 often farmers, own yard and high consumption
- How often?**
- EnvIRONMENTALLY friendly choices
- 4 asks for a good environmental friendly choice, happens sometimes
  - 1 just a few times
  - 3 just ask for a yes or no answer
  - 2 increasing interest
  - 1 asks seldom
- What do customers ask?**
- 7 ask what type of production the electricity comes from
  - 6 do not ask from where
  - 2 mostly focus on nuclearpower
  - 2 most interest in wind and water power
- Who is asking?**

- 1 cis do not have much info to gove customers
- 1 same people who wants to sae energy also saks for

### Load control

#### What do customers ask?

- 5 wants to knowe the times and how it works
- 1 tariffs
- 2 why one should have it
- 4 what can be earned on it
- 1 good response when people understand it

#### How often?

- 2 not a large interest today
- 1 not often chosen today
- mostley wants to quit using it, unprofitable and they do not
- 4 understand how to use it
- 1 many do not even know they have it
- 7 selodm asking for it

### Electricity meters

#### Questions regarding the electricity meter

- 1 how often they are read
- 1 how they work
- 1 influenced by media
- 2 problems with black or blinking display
- 2 Weather they work or not
- 1 meter is in the way and makes sound
- 1 afraid of radiatoin
- 1 mostley elderly that are sceptical towards it

#### How the public reacts to the meter

- the meter is questioned, believe they have got an higher con-
- 7 sumption after the change
- 1 starts to compare to others
- 6 increased consciousness
- 1 wants to know where the meter can be found
- 1 some follow their consumption persistently
- 1 thinks it is good to be able to see measurements
- 1 accepts by time
- have brought on them selves depts since they were not able to
- 1 predict heatin g costs during winter time

#### Asking for further development

- wnats access to read the meter themselfed (living in apart-
- 1 ment)
- 3 wants real time values

- 2 wants daily readings
- wants to know where in the house they have consumed this
- 3 energy
- 2 wants more info at the display
- 1 energy display
- 1 asking of real time prices

**Power quality complaints**

- 1 annoyed when fortum does not have knowledge and control
- 1 over what happens in their grid
- 1 okay with faults if we're taking care of it
- 1 wants top know what happens

## Appendix 3: Answers from CIS interviews Finland

<b>Ämne, antal frågade</b>	<b>antal</b>	<b>svar från handläggare</b>
Fakturering	3	2 Kunden vill påverka sitt faktureringsintervall 1 Ringer ofta och kollar om räkningen blivit betald
Flytt	3	2 En del kunder vet inte att de ska anmäla flytt, tror disponenten fixar 2 Kunden har oftast rätt info att ge (hus) 1 Folk från andra nätområden vet inte att rutinen är annorlunda 1 Folk vet inte vilken info de ska ge (lägenhet)
elräkningen	4	4 Svårt att förstå med utjämningsfakturan. 2 Vissa går igenom fakturan men får inte datum och summor att stämma 4 Svårt att förstå räkningen 1 Svårt att koppla ihop förbrukning från lång tid
Förbrukning	5	1 Kontaktar fortum när elräkningen avviker från det normala 3 Märker förändringar i pris på fakturan 3 Tvivlar på att mätaren fungerar riktigt, skyller på fortum 1 Vill ha en grundlig undersökning vid hög faktura  2 Förstår inte att kall vinter, temperaturförändringar, påverkar 2 Förstår inte att fler apparater hemma påverkar 1 Svårt för kundtjänst att veta vad som ändrats i kundens hem 4 Kunden vill veta VAD som förbrukar hur mycket 4 Förstår inte sambandet förbrukning och pris, beteende/pris 1 Tycker att de inte borde ha förbrukning när de inte är hemma 1 Förstår inte att trasiga maskiner kan förbruka mer 1 Förstår inte eneriflöde 1 Kunde va bra med personlig tips ang. förbrukning  1 Tänker inte så mycket på elen, den bara finns där 2 Kunden ser servicen elen ger, tänker inte på automatiska apparater 1 tänker inte på att man använder el samtidigt på olika ställen, tv + lampa osv  1 Jämför förbrukning med tidigare perioder 1 Jämför med grannen  1 Äldre folk är bättre på att spara 1 Ofta en i hushållet som har ansvar för räkningen

<b>Kunskap hos kunden</b>		1 Vet inte vad de har för apparater i sina hem
	5	2 Vet inte vad som förbrukar hur mycket och vad som påverkar
		1 Tänker inte på stand by läget
		1 Många bäckar små
		2 Lägenhets kunder har sämst koll
		1 Varierande intresse
		1 Kunden vill inte engagera sig
		1 Kunder med större faktura har bättre koll på vad som kostar och vad de har för uppvärmningssystem
		1 Ringer ofta och kollar sin säkring
		1 Ofta de tar för stor säkring till sommarstugan
		1 Dålig koll på vad som är kundens ansvar och fortums ansvar
<b>Driftstörningar</b>		1 Förstår inte vad som orsakar avbrott
	3	2 Bortskämda med att sällan ha avbrott
		3 Vill veta VAD det beror på
		1 Vill veta hur lång tid avbrottet varar
		1 Kunden vill gärna veta om de kan bidra till att förkorta tiden
<hr/>		
<b>Smart grid frågor</b>		
<b>Egen prod</b>		5 Kan de sälja till nätet
	5	1 Vad ställer vi för krav
		2 Frågar sällan
		2 Mest vindkraft
		1 Frågar om de kan sälja till grannen
		1 Frågar om elpriset kommer att stiga, om det kan löna sig
		1 Frågar om egen produktion skulle påverka elpriset
		1 Vill påverka sin egen konsumtion
		1 Mest folk med egnahemshus som frågar
		1 Mest till sommarstugor eller som hobby
<b>AMM</b>		2 Kunden har väntat på automatisk avläsning
	2	1 Folk har annat förbrukningsmönster idag än tidigare, br amed nya förbrukningskurvor
<b>Laststyrning</b>		1 Finns på flera ställen i södra finland
	2	1 Används på varmvatten beredaren
		1 Kunden förstår inte hur elnätet fungerar idag och förstår inte varför man behöver det
		1 Frågar efter nattel eller söndagsel
<b>Lasturkoppling transformator</b>		1 Kunden är skeptisk mot avbrott

	2	1	Tror en komerciell morot skulle va bättre Kunden är säkert kritisk mot bortkoppling, men borde vara intresserad av kortare reparationstid
		1	Vill kunna kontrollera uppvärmningen eller annat viktigt
<b>Info</b>		1	Kundena är intresserad av att få info
	4	1	Vill veta hur många avbrott de har i förhållande till medel eller standard
		1	Kunden vill ha info om varför avbrott sker
		1	Kunden vill ha info på förhand om avbrott som sker
		1	Vissa kunder kritiserar att de inte kan vara med och vara aktiva
<b>automations system</b>		1	Kunden skulle ha lättare att släcka ner på avstånd
	1		
<b>Miljö el</b>		1	Ökat intresse för miljövänligare el nu
	3	1	En del kunder intresserar sig för detta
		1	Ok bara de får höra att det är grön el
		1	Mindre samhällen är mer intresserade

---

<b>Subject, no asked</b>	<b>antal</b>	<b>Answers from CIS agents</b>
Billing	2	The customer has an interest in changing billing interval
3	1	Customers often call to check if they have paid their bill
Mooving	2	Some customers are not aware of the fact that they have to announce when moving
3	2	The customer can usually provide sufficient information
	1	Customers moving in from other grid areas are not used to Fortums routines
	1	Customers do not have sufficient information to give
Electricity bill	4	Customers have difficulties in understanding the leveling bill
3	2	some customers try to go through their electricity bill but cannot add up the sums and the dates
	4	Customers have difficulties in understanding the bill
	1	It seems hard to connect consumption during such long time to daily consumption and behavior
Consumption	1	Make contact when they notice deviations in their bill
3	3	Reacts to changes in price
	3	Doubts the correctness of the meter, blames Fortum for their consumption
	1	Demands an thorough investigation when they get a large bill
	2	Do not understand that a cold winter, changes in temperature, affects
	2	Do not understand that adding more electrical devices to their homes will add to the bill

	1	Customer service have no possibility to see what has changed in their homes
	4	The customers want to know what consumes how much
	4	Can not grasp the connection between consumption and price, behavior and price
	1	Believe that there should be no consumption when they are away from home
	1	Are not aware that broken appliances can have an increased consumption
	1	Do not understand energy flows
	1	Personalized tips concerning consumption would be valuable
	1	Don't consider the electricity, it just exists
	2	The customers notices only the service achieved by an appliance, do not consider automated services
	1	Do not consider the fact that electricity is consumed by several appliances, tv+lightning
	1	Compares their consumption to previous periods in time
	1	Compares their consumption to neighbors
	1	Elderly people are better at saving energy
	1	Most often one person per household who keeps track of bills and there by consumption
Knowledge level, customer	1	People are not aware of what devices they have in their house
5	2	Are not aware of what consumes how much and what affects that
	1	Do not consider devices in stand by mode
	1	Several small costs add up to one big
	2	Customers living in apartments have least insight, consumption
	1	Varying interest in consumption
	1	The customer is not interest in getting involved
	1	Customers with higher normal consumption have better insight
	1	Customers often call to check the size of their main fuse
	1	People often order too large fuse for their summer house
	1	Low insight in what is the customers and what is Fortums responsibility
Network operation disturbances	1	Customers do not understand what can be cause of a disruption
3	2	Customers are spoiled with a low number of disruptions
	3	Customers want to find out what caused the problem
	1	Ask for the expected duration of the disruption
	1	The customer is interested in if they could contribute to shortening the Disruption time

**Smart grid questions**

<b>DG</b>	5	Asks if they can sell surplus electricity to the grid
5	1	Ask what we demand in order for them to connect production
	2	Seldon asks for this
	2	Mostly questions about wind power
	1	Asks if they can sell to neighbors
	1	Interested in whether we think the price for electricity will increase
	1	Asks if own production can influence the electricity price
	1	Want to influence their own consumption
	1	Mostly people with residential houses
	1	People mostly want this for their summer houses or as a hobby
<b>AMM</b>	2	The customers are waiting for this to be implemented
2	1	People have different consumption patterns today, god with new consumption curves
<b>Load control</b>	1	Is used in some places in Finland
2	1	Is used on water heaters
		The customers do not understand grid functionality and cannot understand why
	1	it should be used
	1	Asks for night or Sunday tariffs
<b>Loadcontrol, transformer station</b>	1	Customers are skeptical towards all kinds of interruptions
	1	The customers must be motivated to use this
2	1	Customers are skeptical towards being disconnected, but should be interested in shortened disruption times
	1	Wants to be able to control heating or other important matters
<b>Type of info</b>	1	Customers are interested in getting information about what happens
4	1	are interested in finding out how many disruption they have in comparison to average/regulation
	1	Wants information about why interruption happen
	1	The customer wants to be informed prior to disruptions
	1	Some customers criticize that they are not able to affect things more
<b>Automation system</b>	1	The customer would be interested in automation systems for remote control of their homes
1		
<b>Environmentally ly</b>	1	Increased interest in environmentally friendly electricity
<b>Friend Electricity</b>	1	Some customers are interested in this
3	1	They approve as long as they hear that they buy green electricity
	1	Smaller societies are more interested



