

ECHULA (ECH UpperLauncher) partners:



Fluid dynamics and thermal analysis For the ITER ECH Upper Launcher

A. Vaccaro^a, R. Heidinger^a, W. Leonhardt^b, A. Meier^a,
D. Mellein^b, T. Scherer^a, A. Serikov^c, P. Späh^a, D. Strauß^a

Forschungszentrum Karlsruhe, Association FZK-Euratom

a) Institute for Materials Research

b) Institute for Pulsed Power and Microwave Technology

c) Institute for Reactor Safety

**5th IAEA Technical Meeting on ECRH
Gandhinagar – 18-20 February 2009**



The Upper Launcher in ITER

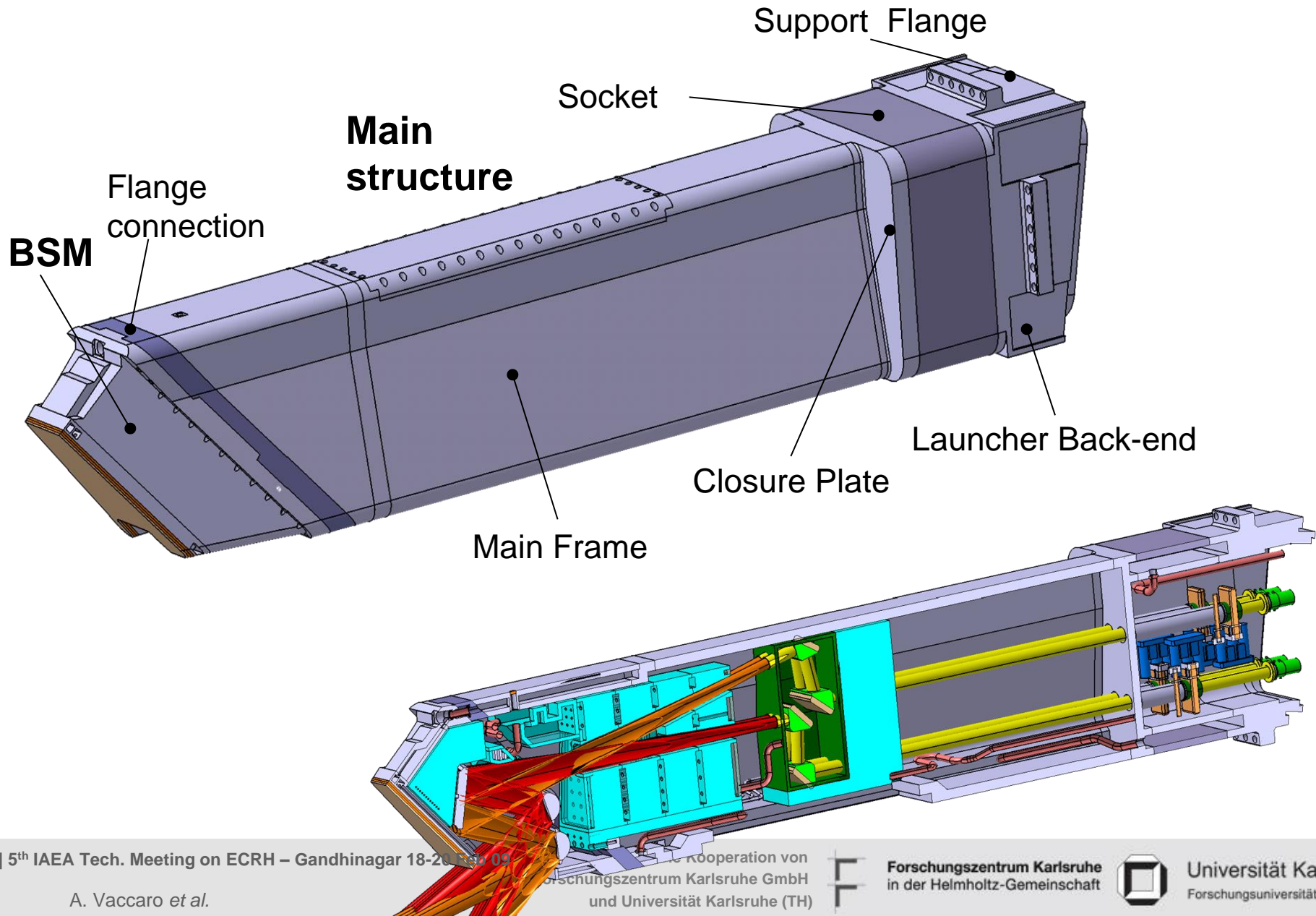

The Blanket Shield Module in the UPP

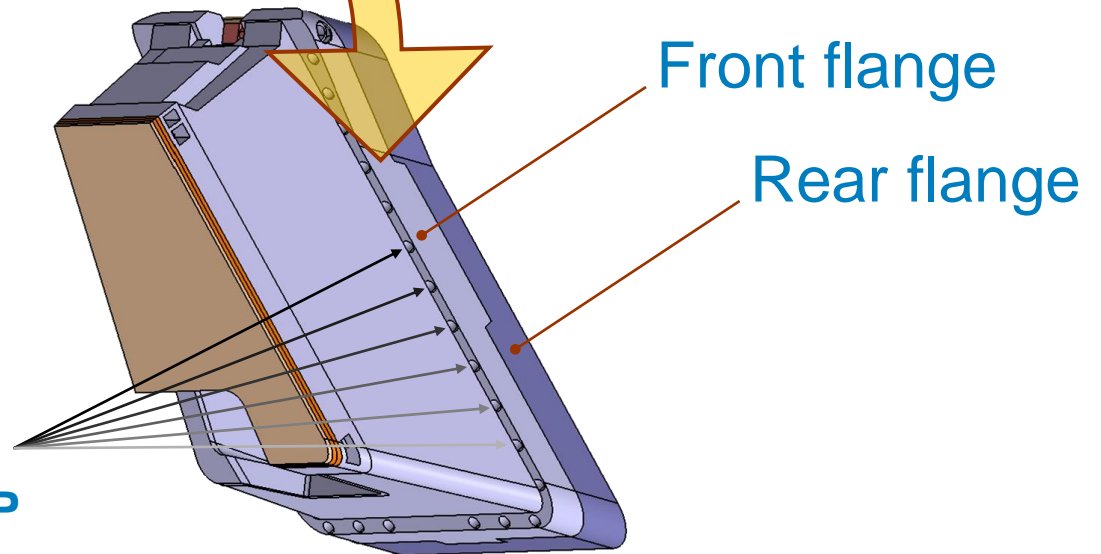
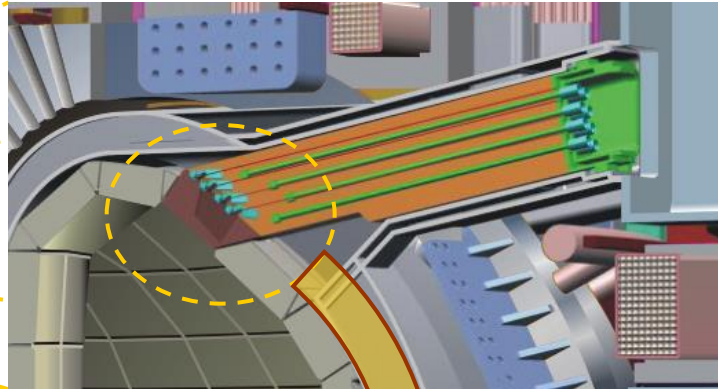
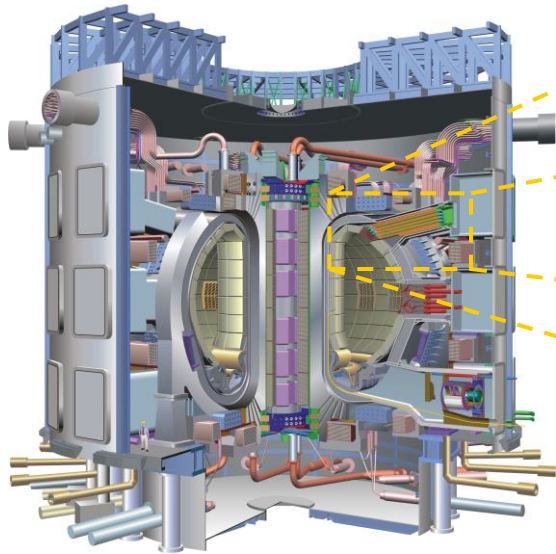

Bolts are used to connect the Blanket Shield Module to the mainframe of the UPP

Modelling Overview

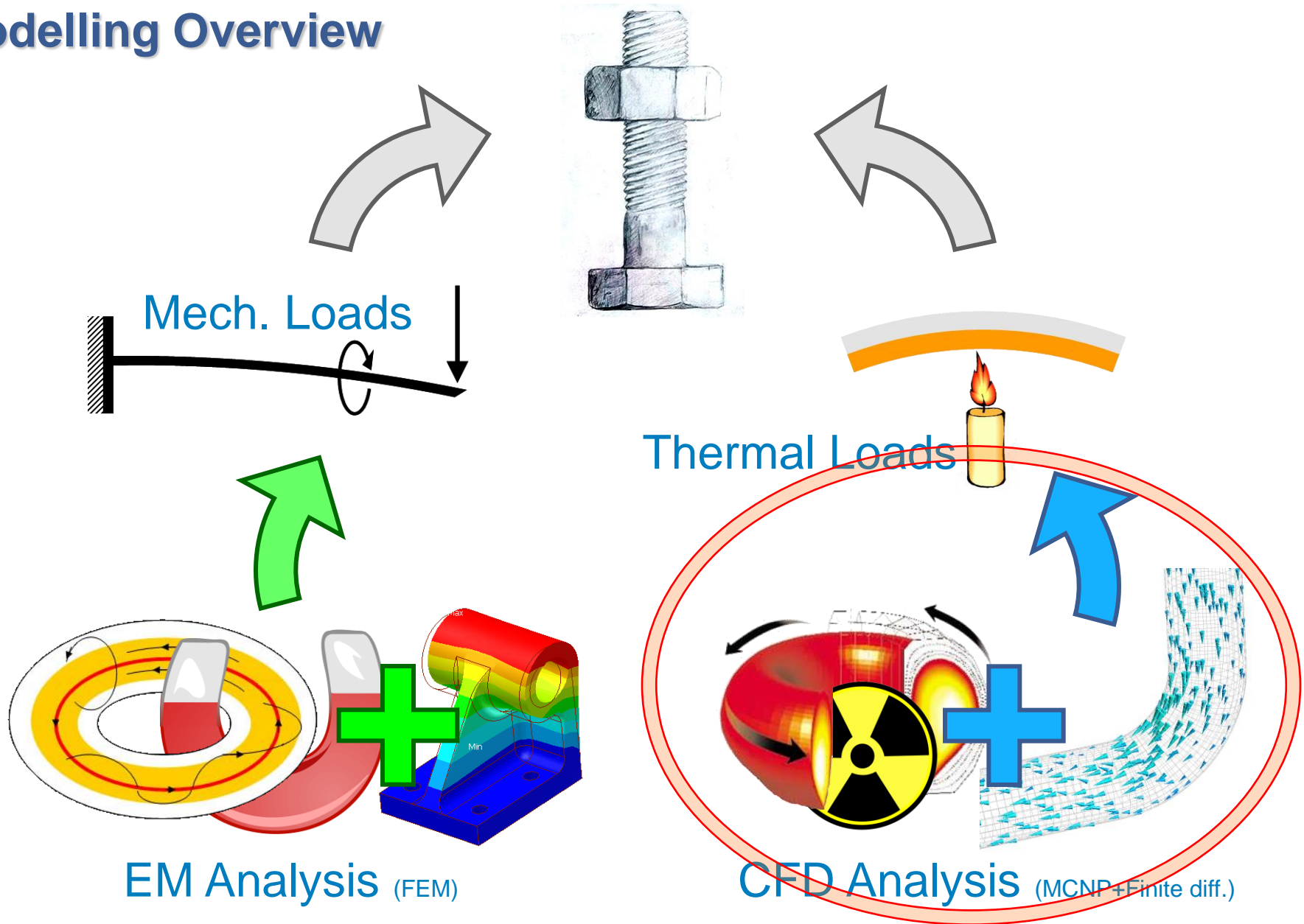

Corner prototype and LHT facility

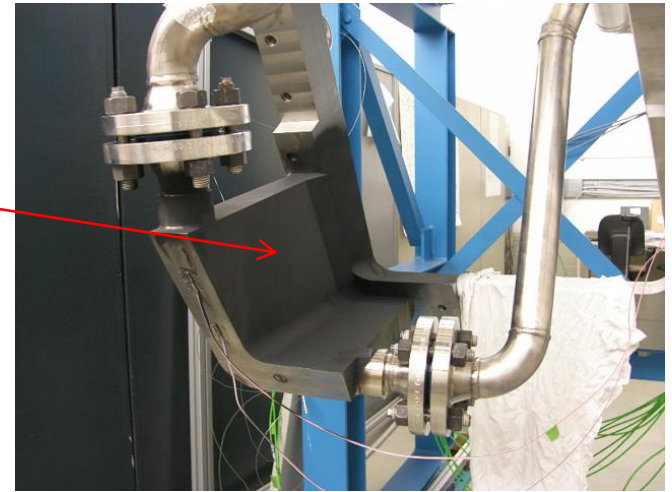
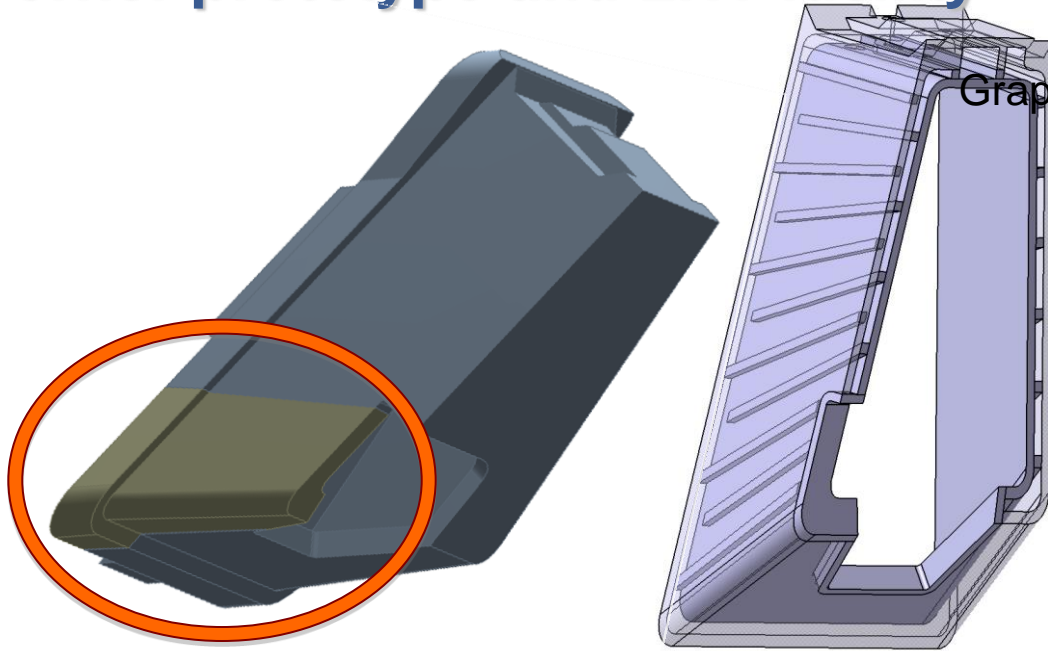

Thermocouples

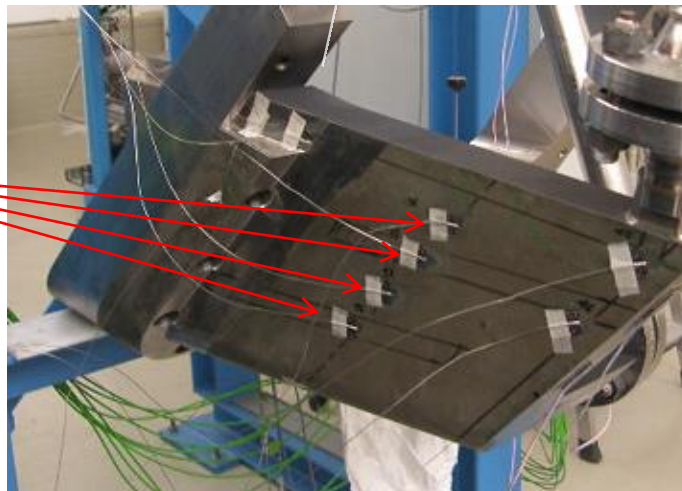

The corner prototype is installed in the Launcher Handling Test facility at FZK. An active circuit provides feedwater at imposed temperature, pressure and mass flow rate.

Shock cooling experiment

The prototype is heated up to 95° C. When the equilibrium is reached, water at 25° C starts flowing into the cooling channel. The temperature is monitored by the thermocouples and IR imaging.

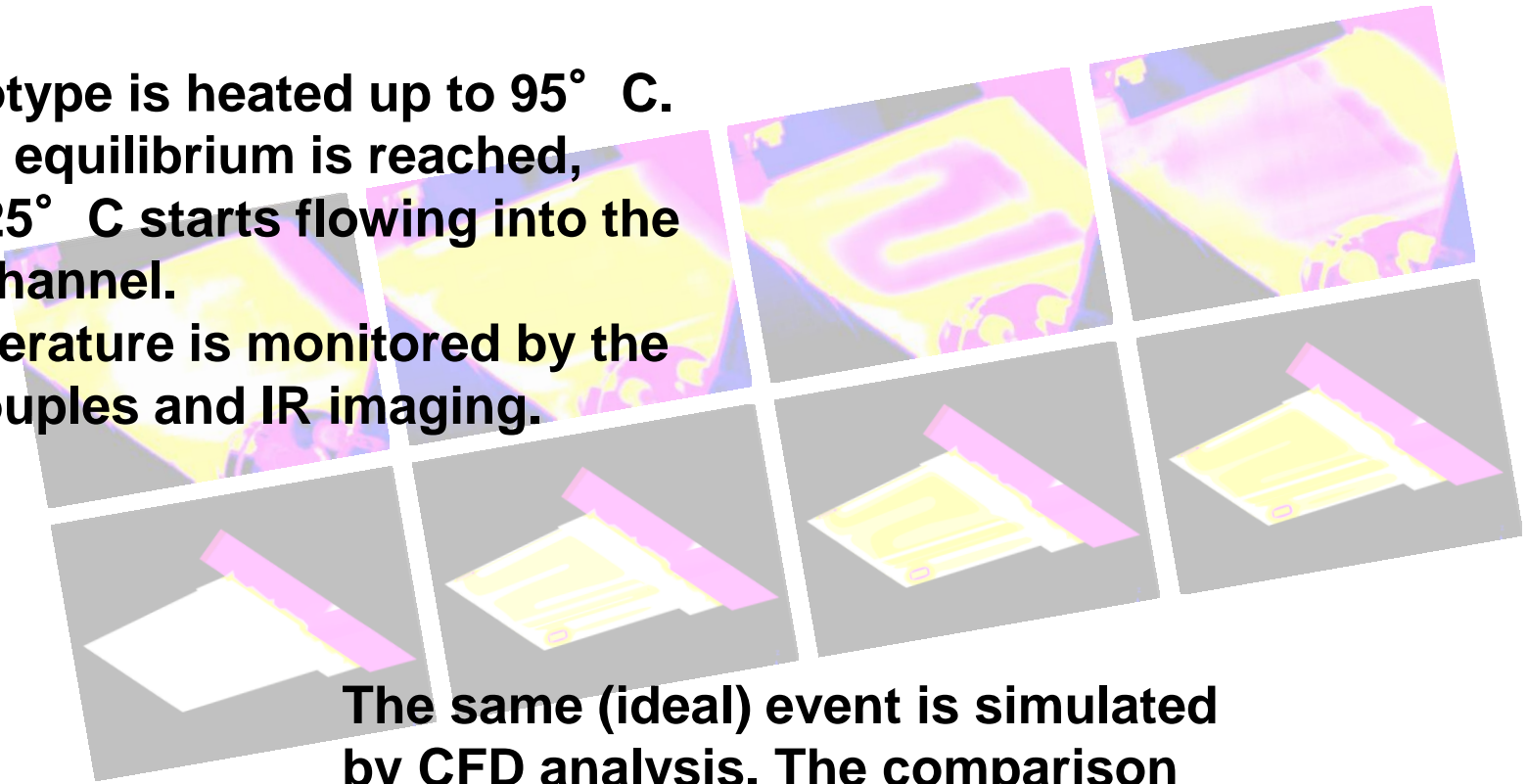

The same (ideal) event is simulated by CFD analysis. The comparison between the simulation and the experiment will provide information about the validity of the model.

CFD Model – The „frozen“ approach

- Constant properties are assumed.
- Steady state analysis to assess the flow field and transport properties
- Transient analysis performed solving only the energy equation.
- Computation time reduced from 1.5 weeks to few hours

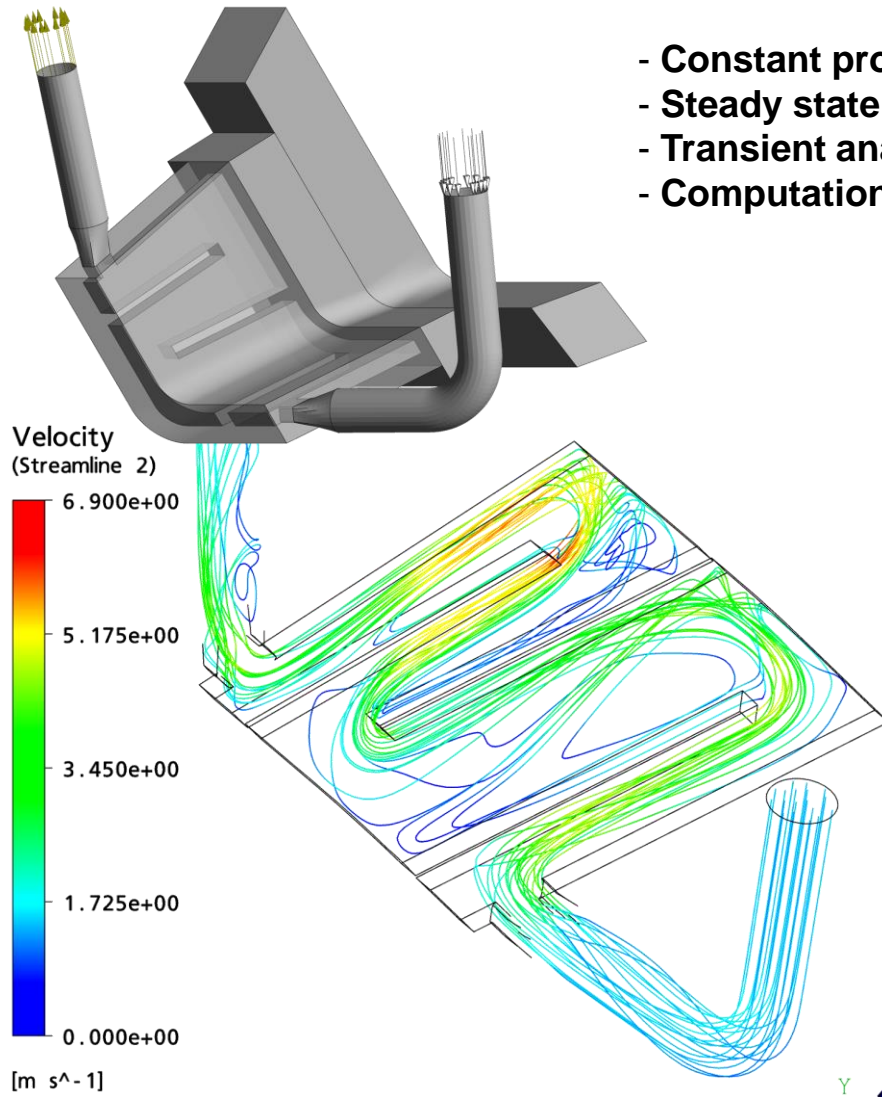

Wall temperatures. Thermocouples

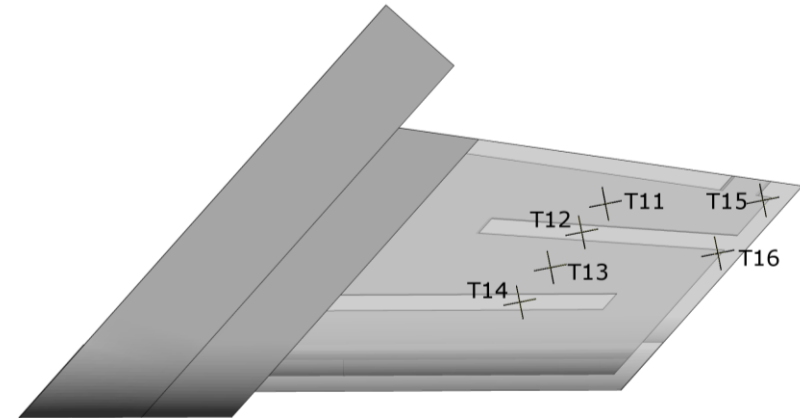
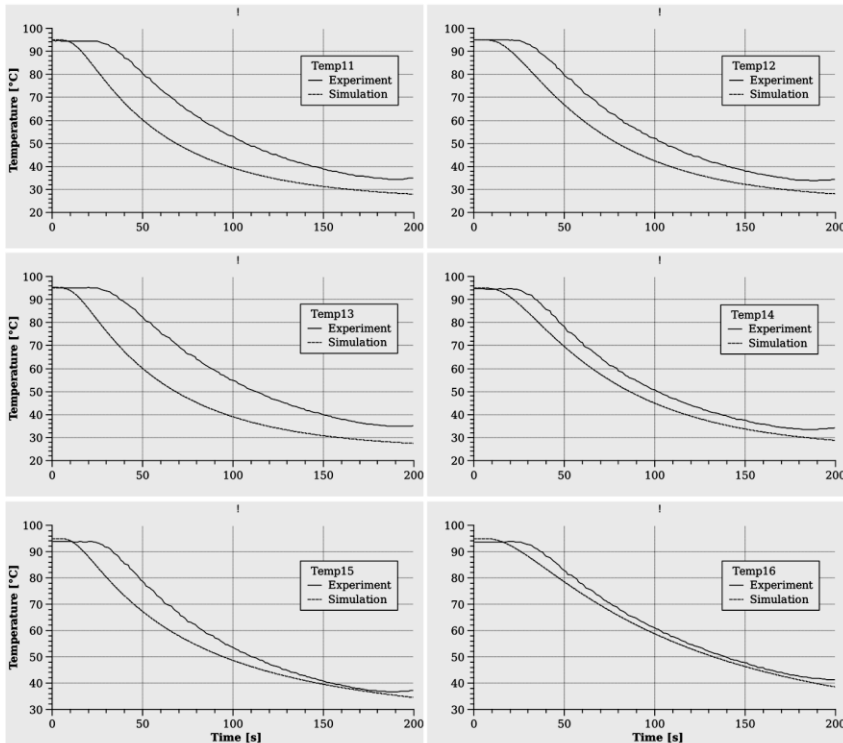

The curves show a good prediction of the heat exchange.

The delays between the curves are determined by the real trends of the inflow.

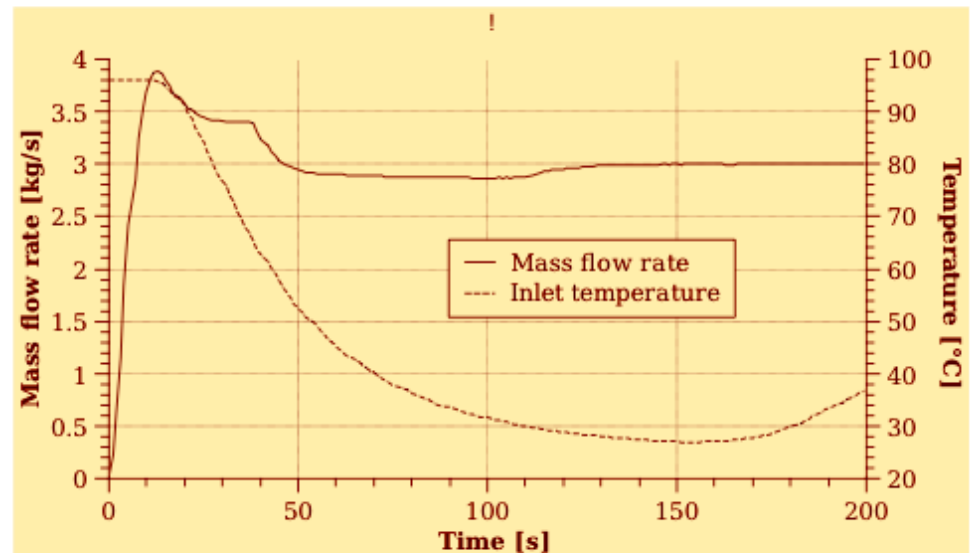

Wall temperatures – IR imaging

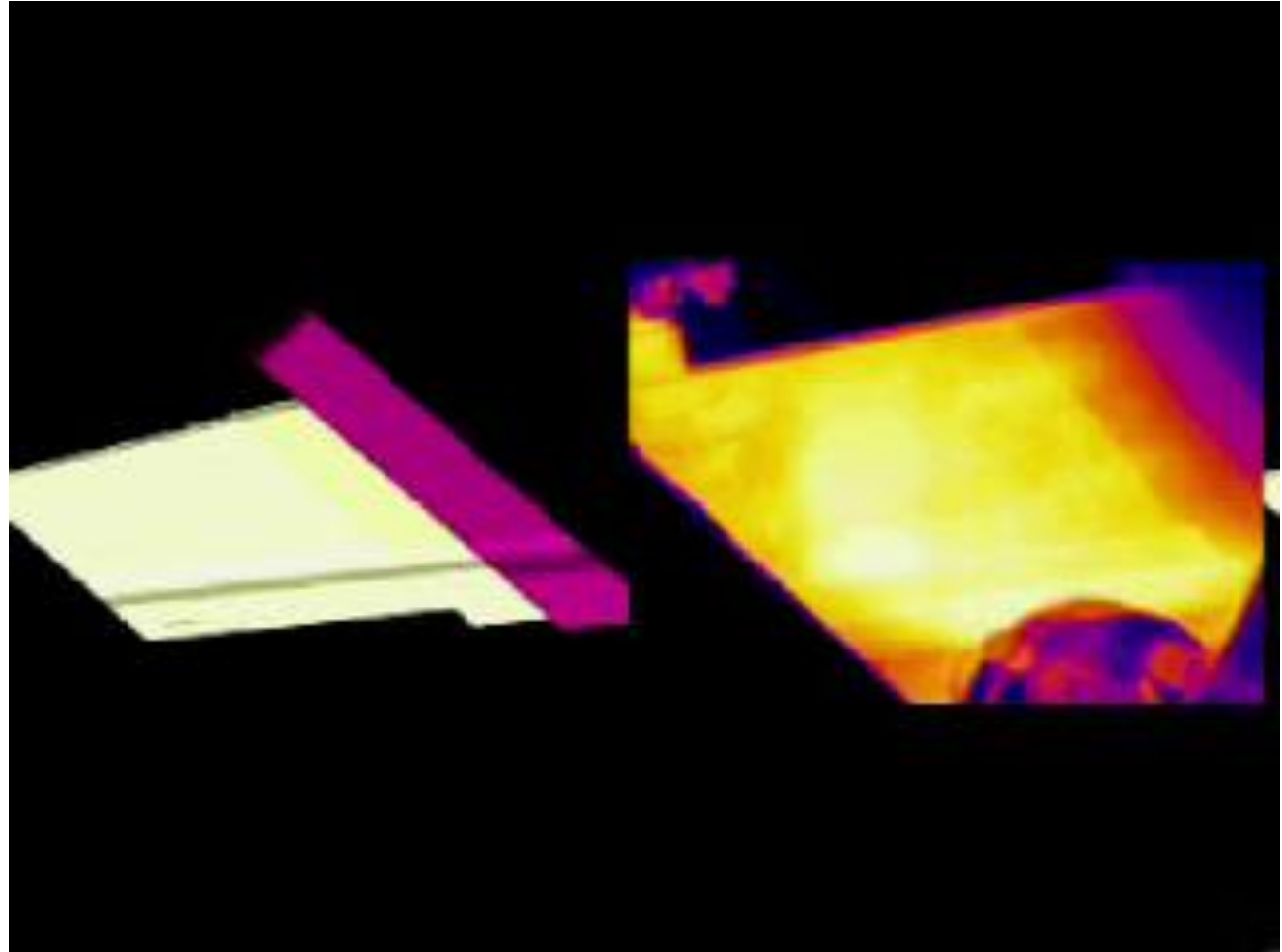
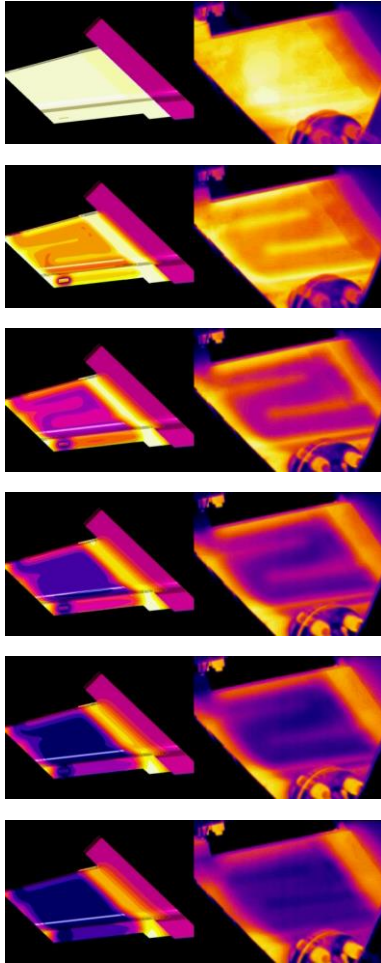

Heat loads on the corner of the BSM

The model is divided into several sectors to take into account of the non-constant heat deposition in the steel and In the water (30-60%!)

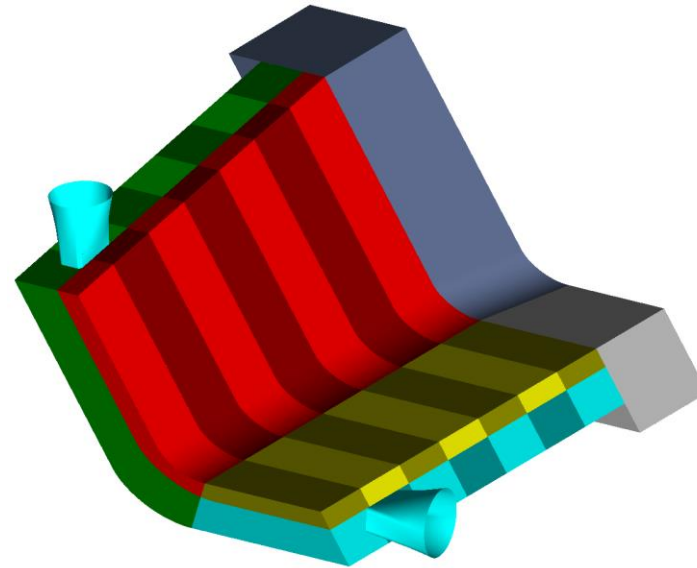
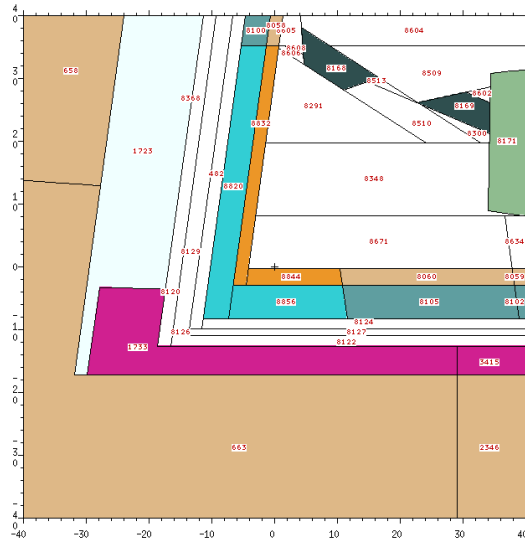
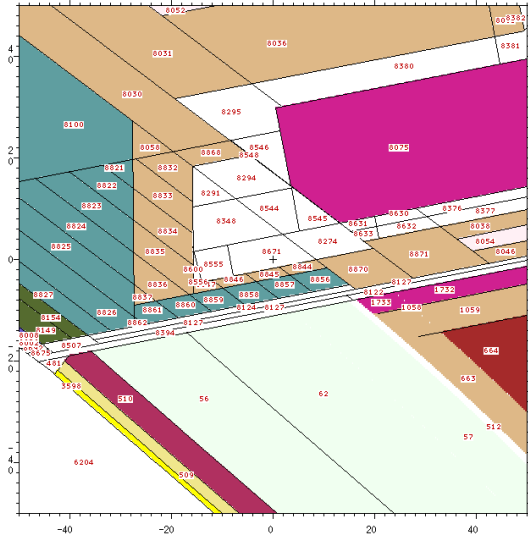

Volumetric heat loads range from 1.6 to 3 MW/m³

Nuclear heating – Steady state study

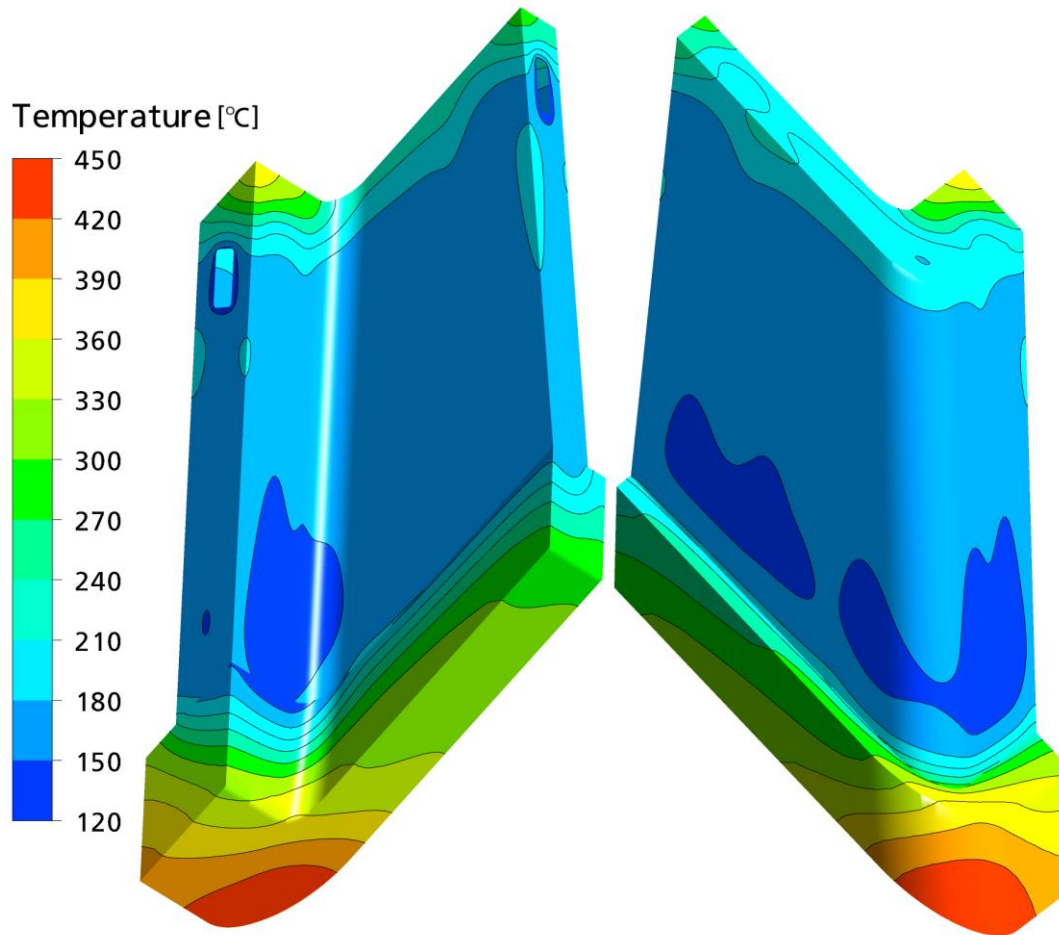

$$\Delta t_{\text{water}} = 11^{\circ} \text{ C}$$

$$G = 4.5 \text{ kg/s}$$

$$P = 138 \text{ kW}$$

High values on the flange

But

The steady-state scenario
is not realistic.

The power production in
ITER is pulsed.

Nuclear heating – Transient study 1

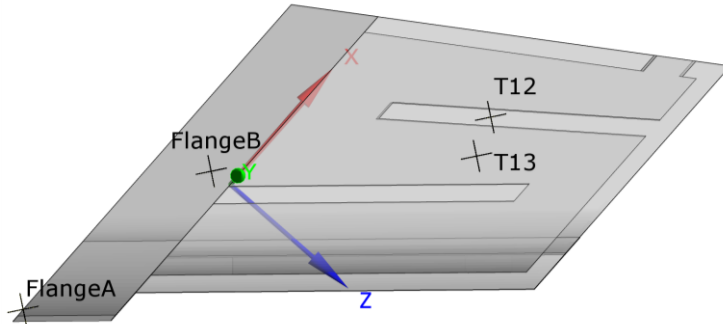

The simulation is performed over 9 successive power cycles each one with 500 s power on followed by 1500 s power off.

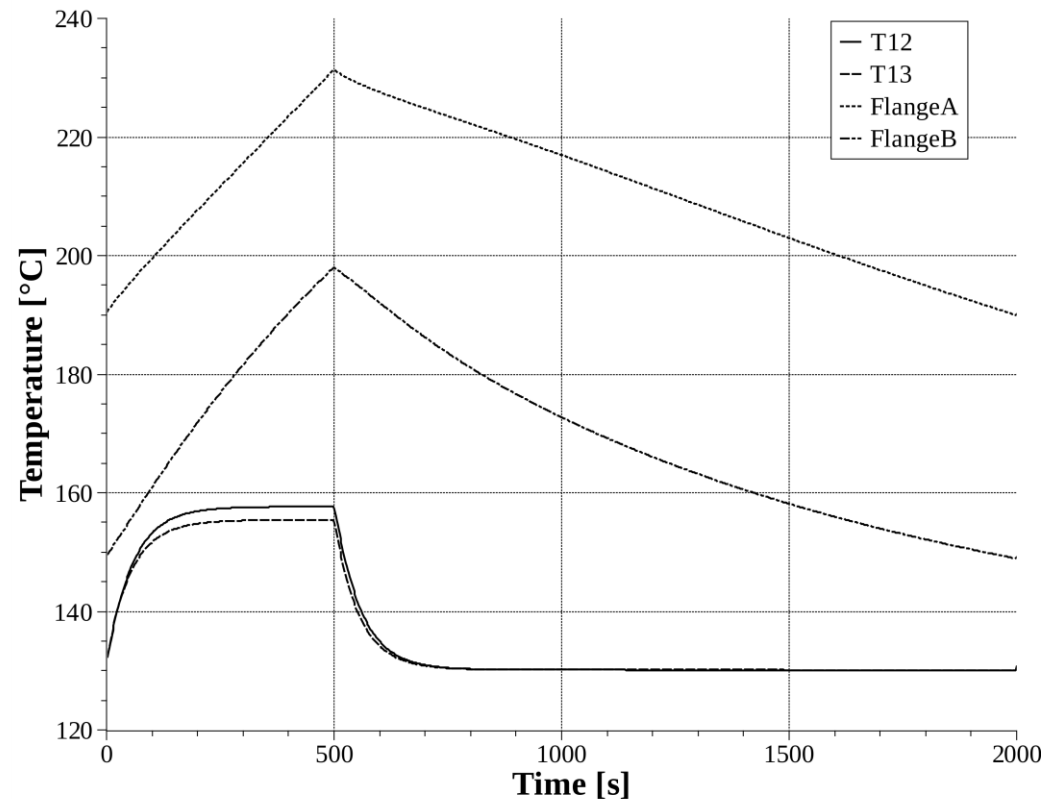

Nuclear heating – Transient study 2

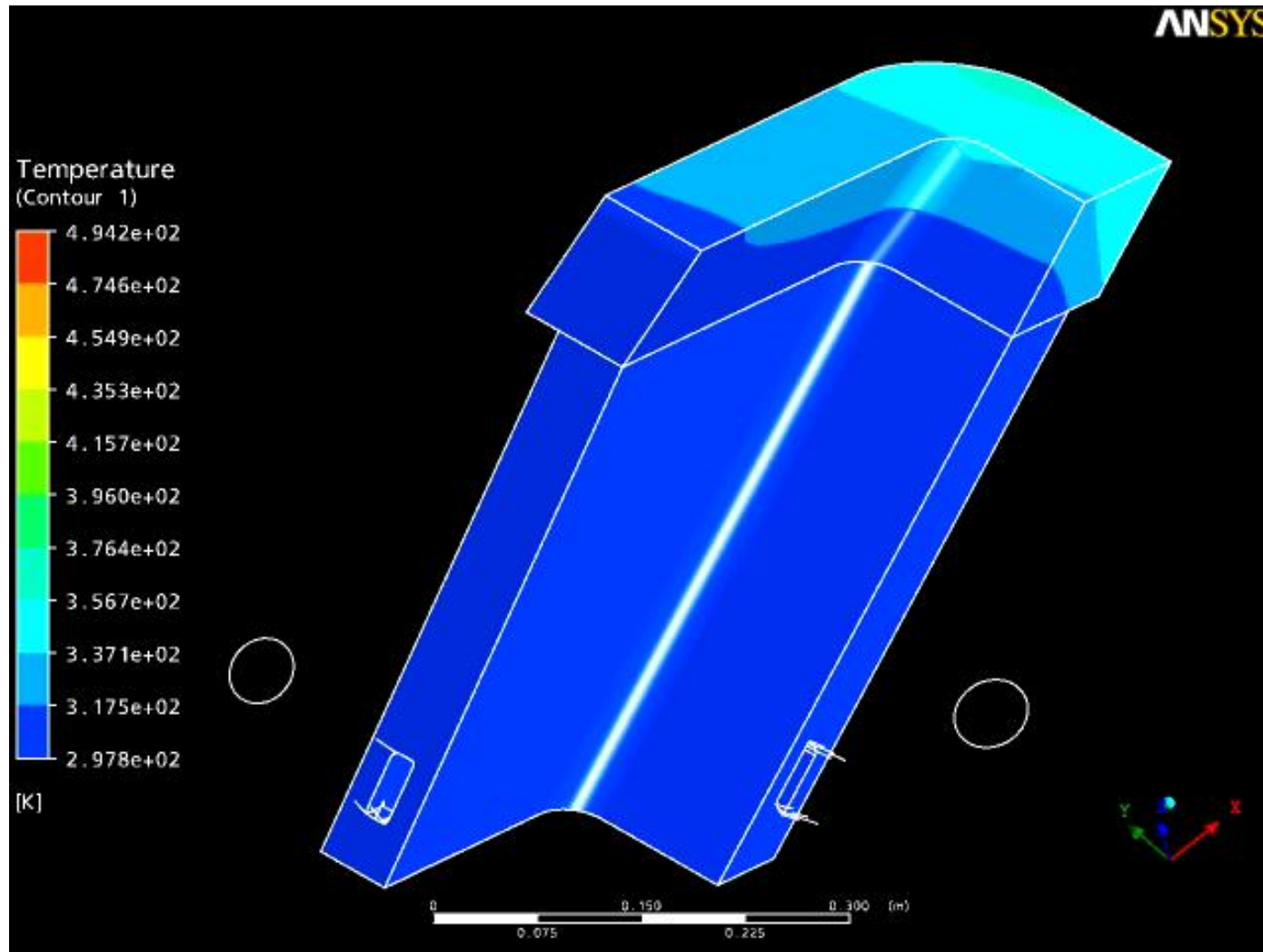

Nuclear heating – Transient study 2

Temperature

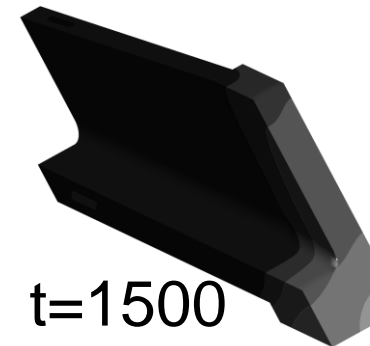
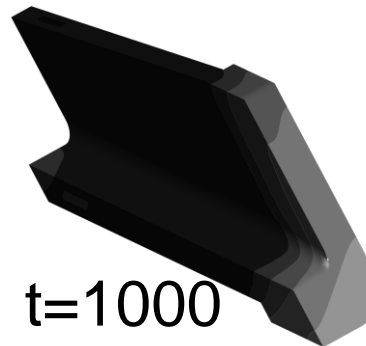
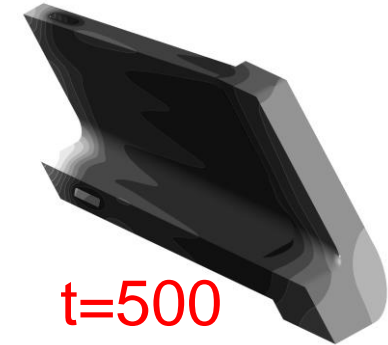
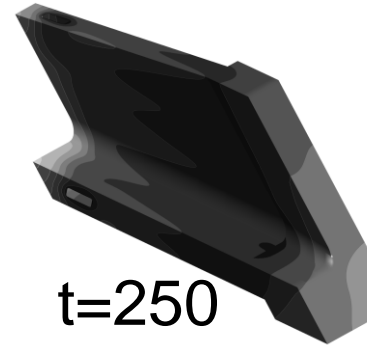
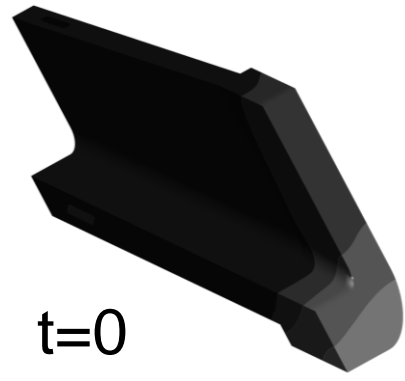
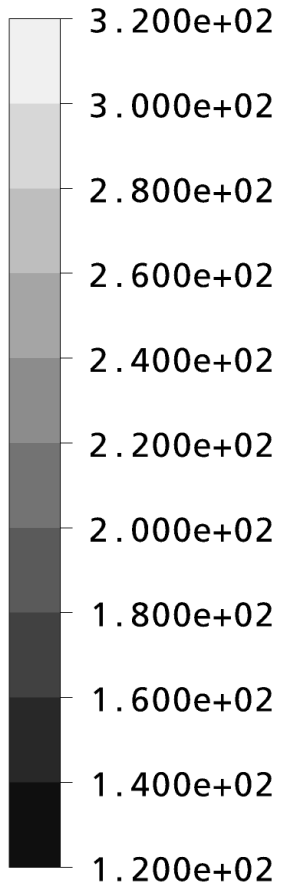

Outlook: extension to the complete cooling circuit

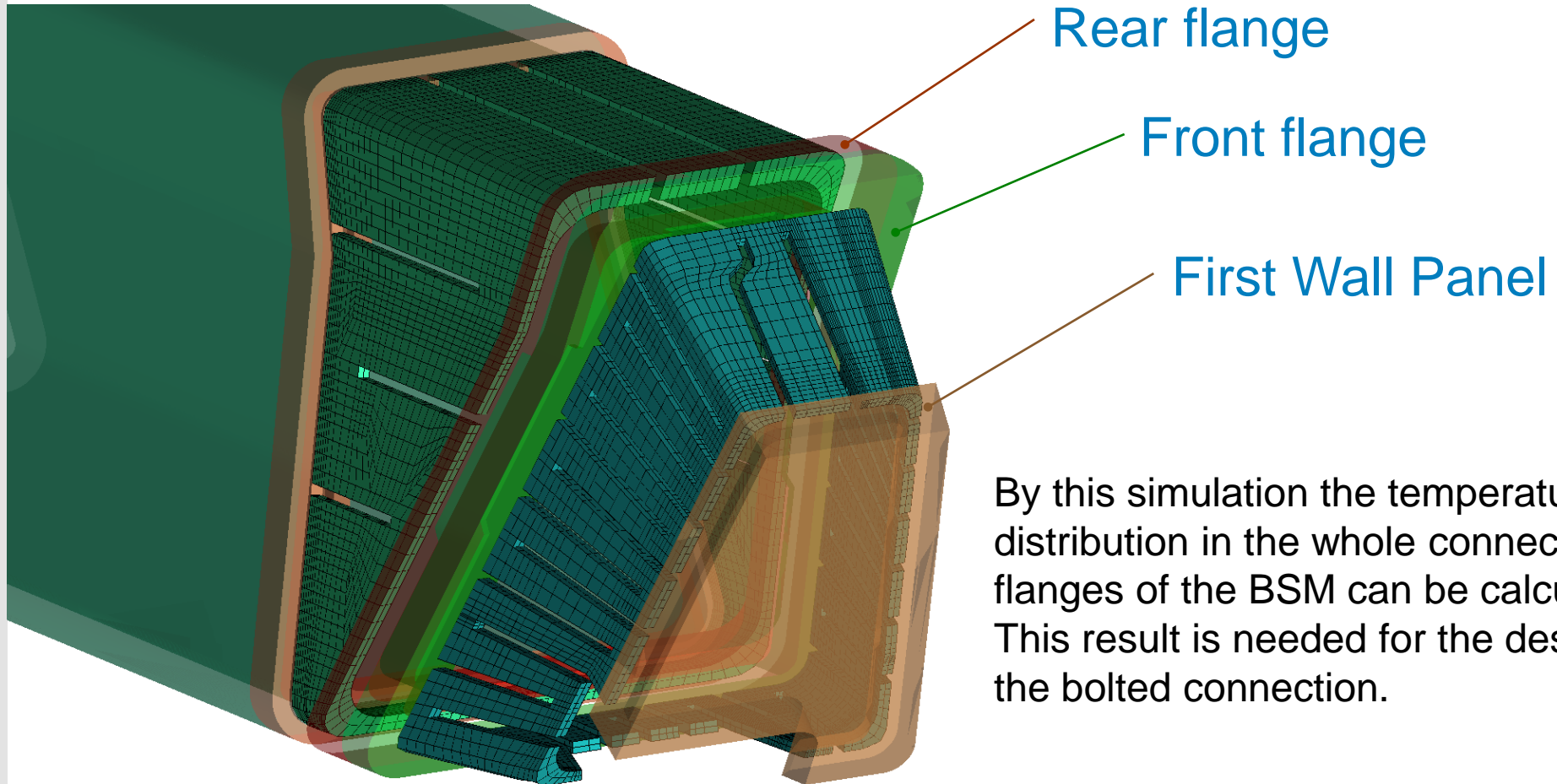

By this simulation the temperature distribution in the whole connecting flanges of the BSM can be calculated. This result is needed for the design of the bolted connection.

Conclusion

The Blanket Shield Module in the UPP is a challenging component due to the high thermal and mechanical loads to which it is subjected.

The shock-cooling experiments on the corner prototype and the CFD simulation presented in this paper are used as instrument to verify the efficacy of the cooling system.

The results also show that the cooling system is able to cool efficiently the walls and the flange of the BSM, when the nuclear heat production and the pulsed operation of the ITER reactor are taken into account.

Modelling is a necessary tool for the design of some key features of the UPP, like the bolted connection of the BSM and the fixation of the entire structure to the Upper Port.