

Integrated Lead Time and Demand Risk Pooling Strategies in Multi-Echelon Distribution Systems

Zur Erlangung des akademischen Grades eines

Doktors der Wirtschaftswissenschaften

(Dr. rer. pol.)

bei der Fakultät für Wirtschaftswissenschaften

des Karlsruher Instituts für Technologie (KIT)

genehmigte

DISSERTATION

von

M.Sc. Mahdi Moghadasian

Tag der Mündlichen Prüfung: 05.12.2016

Referent: Prof. Dr. Stefan Nickel

Korreferent: Prof. Dr. Kai Furmans

Prüfer: Prof. Dr. Thomas Setzer

Karlsruhe, 2016



This document is licensed under the Creative Commons Attribution – Share Alike 3.0 DE License (CC BY-SA 3.0 DE): <http://creativecommons.org/licenses/by-sa/3.0/de/>

Integrated Lead Time and Demand Risk Pooling Strategies in Multi-Echelon Distribution Systems

Acknowledgements

This thesis represents not only my work at the keyboard, it is a milestone in more than four years of work at KIT and specifically within Institute for Material Handling and Logistics (IFL). My experience at KIT has been nothing short of amazing. I have been given unique opportunities... and taken advantage of them. This includes working as a tutor for the lectures, and involvement in an industry and a research project. It is completely true that the most critical step in obtaining a Dr. degree is to succeed in making a dot at the end.

It was not possible to finish this research without the support and guidance from numerous people. First and foremost, I wish to thank my advisors, Prof. Dr. Stefan Nickel, head of the Chair of Discrete Optimization and Logistics, and Professor Dr. Kai Furmans, head of the Institute for Material Handling and Logistics at KIT. Both of them have been supportive since I began working on my research topic. My thanks also to Professor Dr. Thomas Setzer for being part of the examination committee and giving a quick feedback, and to Professor Dr. Rudi Studer for his sincere conduct as the chairman of the examination committee.

I have to also thank Professor Dr. Pandu Tadikamalla for his great support both scientifically and emotionally during my visit for more than six months from University of Pittsburgh in Pittsburgh, USA. This trip was financially supported by Karlsruhe House of Young Scientists (KHYS) at KIT. Thanks to KHYS people for this support, especially Mrs. Gaby Weick. She is a really nice lady. Great thanks to Dr. Helmut Wlcek, who always helped me eagerly during the numerical analysis of my research models. I learned a lot from him. I would also like to express my gratitude to Professor Morris A. Cohen from Wharton Business School at University of Pennsylvania for his comments on my topic.

A second group of people who I would like to express my gratitude are my colleagues and friends in Karlsruhe. I was lucky to work with so many nice

Acknowledgements

and knowledgeable colleagues at IFL. My thanks to Logistic team at IFL, especially to Dr. Eda Özden and Martin Epp, who are not only my colleagues but also my best friends. I have to express my gratitude to Dr. Judith Stoll, Dr. Judith Schmid, Christoph Kunert and Marcel Mertin, too. I cannot also forget my friends in Karlsruhe who helped me a lot. Dr. Hadi Taheri, Vahid Nokhbeh, Sonia Alikhah, Dr. Payam Dehdari, and Georg Nicola, just to name a few.

And very important, I would like to thank my family, my parents and my sisters, for always being there, and providing the opportunity to achieve my goals and dreams in my entire life. Finally, many thanks to Mahsa, too. Since we have been together, she has never stopped supporting me. She was definitely a great help, especially at the final stressful phase of my PhD research.

Mahdi Moghadasian
Karlsruhe, December 2016

Abstract

Consolidated distribution and order splitting are two risk pooling strategies which pool demand and lead time, respectively. In this research work, we intend to examine the impact of the integration of these two concepts on the total logistics cost. To achieve this aim, we propose four mathematical models. The first model is the traditional logistic system which we call a Direct Shipping system (DS model). Then, we develop a Direct Shipping model with Order Splitting (DSOS model). Further, the traditional multi-echelon distribution system consisting of one supplier, one distribution center, and multiple retailers is presented. In the latter system, a Distribution Center (DC) consolidates the order quantity of all retailers. This is the Consolidated Distribution system (CD model). Finally, we integrate and extend these models to a Consolidated Distribution Order Splitting system (CDOS model).

We investigate whether the integration of consolidated distribution and order splitting increases the advantages while simultaneously decreases the shortcomings of both strategies, in comparison to the cases where none or only one of these two concepts is implemented. In this work, our mathematical models consider stochastic demand and lead time. We used the method of moments to compute the parameters of lead time, demand and lead time demand distribution. Unlike most of order splitting research, the order quantity is split and delivered by one single supplier.

We evaluate the performance of the total annual cost of the DSOS, CD, and CDOS models over the DS model and call our key performance indicator as “percentage increase/decrease over the DS model”. The results indicate that, among all models, the CDOS has the best performance over the DS model. Next to the CDOD and with a slight difference, the CD model performs well. Quantity discounts are the main reason for the superiority of these two models in our logistics model. The DSOS model has a worse performance than the DS model.

To further understand the impact of each strategy on total logistics cost, we

Abstract

did a sensitivity analysis of average daily demand, number of retailers, split proportion, lead time mean, coefficient of variation, and average purchasing price. Again, for the given input, we realized that the CDOS and CD models, respectively, have a better performance over the DS and DSOS models, and the DSOS model performs worse than the DS model. In addition, the CDOS model has a better performance than the CD model in most cases. However, the performance of all the four models may change based on the increase or decrease in the value of parameters mentioned.

Contents

Acknowledgements	iii
Abstract	v
Acronyms	xiii
Notational Terms	xv
1 Introduction	1
1.1 Scope of the Research	1
1.2 Problem Description and Research Questions	2
1.3 Structure of the Research Work	6
2 Review of the Related Research	9
2.1 Risk Pooling	9
2.2 Consolidated Distribution	11
2.3 Order Splitting	14
2.3.1 Literature Review before 2006	14
2.3.2 Review of post 2006 Literature	20
2.4 Interaction of Consolidated Distribution and Order Splitting	28
3 Mathematical Modeling of the Four Strategies	33
3.1 Notational Terms	33
3.2 Optimization Models	36
3.2.1 Direct Shipping without Order Splitting (DS Model)	38
3.2.2 Direct Shipping with Order Splitting (DSOS Model)	40
3.2.3 Consolidated Distribution without Order Splitting (CD Model)	41
3.2.4 Integration of the OS and CD Systems (CDOS Model)	44
3.3 Computation of Cycle and Safety Stock in Order Splitting Model	45

Contents

3.4	Probability of Stock-out in Order Splitting Model	48
3.4.1	Computing the Probability of Situation i	49
3.4.2	Defining Lead Time Distributions	50
3.4.3	Computing the Cumulative Distribution Functions for Order Splitting Model	50
3.5	Computing Cumulative Distribution Functions in Case of Non- Order Splitting	52
4	Evaluation and Results of the Four Strategies	53
4.1	Computing the Inputs of the Models	53
4.1.1	General Procedure for Computing the Moments of Beta and Exponential Distributions	56
4.1.2	Numerical Computation of the Parameters of Weibull Distribution for the DS Model	58
4.1.3	Numerical Computation of the Parameters of a Weibull Distribution for the DSOS Model	59
4.1.4	Numerical Computation of the Parameters of Weibull Distribution for the CD Model	61
4.1.5	Numerical Computation of the Parameters of Weibull Distribution for the CDOS Model	63
4.2	Results	66
4.2.1	Numerical Analysis with the Basic Parameter Values . .	66
4.2.2	Sensitivity Analysis	68
4.2.2.1	Impact of Demand	68
4.2.2.2	Impact of Number of Retailers	79
4.2.2.3	Impact of Split Proportion	83
4.2.2.4	Impact of Lead Time Mean	88
4.2.2.5	Impact of Coefficient of Variation of Lead Time	91
4.2.2.6	Impact of Purchasing Price	93
4.2.3	Summary of the Results	97
5	Discussion and Summary	99
5.1	Discussion of the Findings	99
5.2	Summary	102
5.3	Research Limitations and Future Directions for Research	104

List of Figures

1.1	Order splitting over time	5
2.1	Risk pooling research since its introduction (adopted from Oeser (2010))	11
2.2	Integration of consolidated distribution and order splitting	30
3.1	The cost structure	37
3.2	Traditional (Q, R) inventory policy	46
3.3	Oder splitting over suppliers	47
3.4	Order splitting over time (a single supplier)	47
4.1	Order quantity for different values of demand	71
4.2	Impact of change in demand value on TAC	71
4.3	% increase/decrease in TC over the DS model for different values of demand	72
4.4	% increase/decrease in CSC over the DS model for different values of demand	73
4.5	% increase/decrease in OC over the DS model for different values of demand	74
4.6	Transportation cost per unit for different values of demand	76
4.7	Simulation of transportation cost per unit for LTL shipments	76
4.8	Simulation of transportation cost per unit for FTL and LTL shipments	77
4.9	% increase-decrease in CSC over the DS model for different values of demand	78
4.10	% increase/decrease in SSC over the DS model for different values of demand	78
4.11	Impact of change in number of retailers on TAC	80
4.12	Order quantity for different number of retailers	81

List of Figures

4.13	% increase/decrease in PC over the DS model for different number of retailers	82
4.14	% increase/decrease in CSC over the DS model for different number of retailers	82
4.15	% increase/decrease in SSC over the DS model for different number of retailers	83
4.16	Impact of change in split proportions on TAC	85
4.17	Order quantity for changes in split proportion	86
4.18	% increase/decrease in TC over the DS model for different split proportions	87
4.19	% increase/decrease in CSC over the DS model for different split proportions	87
4.20	Impact of change in lead time mean on TAC	89
4.21	% increase/decrease in SSC over the DS model for different lead time mean	90
4.22	% increase/decrease in ITC over the DS model for different lead time mean	90
4.23	Impact of change in Coefficient of Variation (CV) of lead time on TAC	92
4.24	% increase/decrease in SSC over the DS model for different values of CV	93
4.25	Impact of change in purchasing price on TAC	95
4.26	Order quantity for changes in purchasing price	96
4.27	% increase/decrease in TC over the DS model for different purchasing prices	97
4.28	% increase-decrease in OC over the DS model for different purchasing prices	98
4.29	% increase/decrease in CSC over the DS model for different purchasing prices	98

List of Tables

2.1	Risk pooling methods' building blocks (adopted from Oeser (2010))	10
2.2	Factors influencing the decision on single and multiple sourcing (adopted from Mishra and Tadikamalla (2006))	15
2.3	The main logistic cost elements in the literature before 2006 . .	21
2.4	The main logistic cost elements considered in the literature since 2006	29
4.1	Value of the parameters	55
4.2	Computation of moments and Weibull parameters for the DS model	58
4.3	The first three raw moments of the LT distribution for the DSOS model	60
4.4	The first three central moments of the LT distribution for the DSOS model	60
4.5	First three raw and central moments of demand distribution in the DSOS model	60
4.6	The first three central moments of the LTD distribution for the DSOS model	61
4.7	The location, scale and shape parameters of the LTD distribution for the DSOS model	61
4.8	Computation of moments and Weibull parameters for retailers in the CD model	62
4.9	Computation of moments and Weibull parameters for DC in the CD model	63
4.10	Computation of moments and Weibull parameters for retailers in the CDOS model	63
4.11	The first three raw moments of LT distribution for the CDOS model	64

List of Tables

4.12	The first three central moments of LT distribution for the CDOS model	65
4.13	First three raw and central moments of demand distribution in the CDOS model	65
4.14	The first three central moments of LTD distribution for the CDOS model	65
4.15	The location, scale and shape parameters of LTD distribution for the CDOS model	65
4.16	Optimal solution for the given parameter values	66
4.17	The absolute value of logistic cost elements (\$)	67
4.18	Total annual logistics cost with and without purchasing cost . .	68
4.19	Impact of different values of demand on total annual cost	70
4.20	Transportation cost per unit for different values of demand . . .	72
4.21	Cycle stock cost per unit for different values of demand	73
4.22	Ordering cost per unit for different values of demand	74
4.23	% increase/decrease in PC over the DS model for different values of demand	75
4.24	Impact of number of retailers on total annual cost	79
4.25	Impact of split proportion on total annual cost	84
4.26	Impact of lead time mean on total annual cost	89
4.27	Impact of coefficient of variation of lead time on total annual cost	91
4.28	% increase/decrease in SSC over the DS model for different values of CV	92
4.29	Impact of purchasing price on total annual cost	94
4.30	% increase/decrease in PC over the DS model for different purchasing prices	96

Acronyms

CD: Consolidated Distribution

CDOS: Consolidated Distribution Order Splitting

CSC: Cycle Stock Cost

CV: Coefficient of Variation

DC: Distribution Center

DS: Direct Shipping

DSOS: Direct Shipping Order Splitting

ITC: In-Transit stock Cost

KPI: Key Performance Indicator

LT: Lead Time

LTD: Lead Time Demand

OC: Ordering Cost

OS: Order Splitting

PC: Purchasing Cost

SSC: Safety Stock Cost

TAC: Total Annual Cost

TC: Transportation Cost

Notational Terms

TAC_{noOS}^{noCD} : total annual system cost in the case of Direct Shipping to retailers without order splitting (DS model);

TAC_{OS}^{noCD} : total annual system cost in the case of Direct Shipping to retailers with order splitting (DSOS model);

TAC_{noOS}^{CD} : total annual system cost in the case of Consolidated Distribution without order splitting (CD model);

TAC_{OS}^{CD} : total annual system cost when both Consolidated Distribution and Order Splitting are implemented (CDOS model);

Q_n : order quantity at retailer n ;

Q_0 : order quantity at DC, $Q_0=Q_nN$, which is the multiplication of order quantity at a single retailer by the total number of retailers N . All retailers are identical;

R_n : reorder point at retailer n ;

R_0 : reorder point at DC;

N : total number of retailers, where $n = 1, 2, \dots, N$;

D_n : total annual demand at retailer n ;

D_0 : total annual demand at DC, $D_0= D_nN$, which is the multiplication of total annual demand at a single retailer by the total number of retailers N ;

c : unit purchasing price from the supplier which is a function of order quantity, where $q^k < Q_n \leq q^{k+1}$ and $q^k < Q_0 \leq q^{k+1}$, and q^k is the k^{th} price breakpoint in the price table;

r_i : i^{th} proportion of order quantity which is transported by the supplier to DC or retailer n , where $i = 1, 2$ and $\sum_{i=1}^I r_i = 1$;

w : item weight;

T : shipment weight, where $T = Q_nw$ or $T = Q_0w$;

Z : distance between two facilities;

TC : total transportation cost which is a function of shipment weight T and distance Z ;

O : cost of placing an order at DC or retailers;

Notational Terms

B : cost of receiving an order at DC or retailers;

A : a multiple for receiving cost of an split order ($A > 1$) representing the incremental cost of splitting orders which is the same at DC and retailers;

H_n : annual inventory holding cost of an item at retailer n expressed as a percentage of value of an item;

H_0 : annual inventory holding cost of an item at DC expressed as a percentage of value of an item;

H_0^{it} : annual inventory in-transit cost of an item from supplier to DC expressed as a percentage of value of an item;

H_n^{it} : annual inventory in-transit cost of an item from supplier or DC to retailer n expressed as a percentage of value of an item;

t : a variable representing transit time;

η : a fixed order-to-ship time component of lead time;

l : a variable representing lead time;

d : a variable representing daily demand;

$\mu(l_{s0i})$: mean of the lead time from supplier to DC for the i^{th} proportion of Q_0 (in case of order splitting), where $i = 1, 2$;

$\mu(l_{sni})$: mean of the lead time from supplier to retailer n for the i^{th} proportion of Q_n (in case of order splitting), where $i = 1, 2$;

$\mu(l_{sn})$: mean of the lead time from supplier to retailer n (in case of no order splitting);

$\mu(l_{s0})$: mean of the lead time from supplier to DC (in case of no order splitting);

$\mu(l_{0n})$: mean of the lead time from DC to retailer n (in case of no order splitting);

$\mu(t_{sn})$: mean of the transit time from supplier to retailer n ;

$\mu(t_{s0})$: mean of the transit time from supplier to DC;

$\mu(t_{0n})$: mean of the transit time from DC to retailer n ;

$\mu(d_n)$: mean of the daily demand at retailer n ;

$\mu(d_0)$: mean of the daily demand at DC;

$\mu(LTD_{s0i})$: mean of the lead time demand from supplier to DC for the i^{th} proportion of Q_0 (in case of order splitting);

$\mu(LTD_{sni})$: mean of the lead time demand from supplier to retailer n for the i^{th} proportion of Q_n (in case of order splitting);

$\mu(LTD_{sn})$: mean of the lead time demand from supplier to retailer n (in case of no order splitting);

$\mu(LTD_{s0})$: mean of the lead time from supplier to DC (in case of no order splitting);
 $\mu(LTD_{0n})$: mean of the lead time from DC to retailer n (in case of no order splitting);
 $\sigma(l_{s0i})$: standard deviation of the lead time from supplier to DC for the i^{th} proportion of Q_0 (in case of order splitting);
 $\sigma(l_{sni})$: standard deviation of the lead time from supplier to retailer n for the i^{th} proportion of Q_n (in case of order splitting);
 $\sigma(l_{sn})$: standard deviation of the lead time from supplier to retailer n (in case of no order splitting);
 $\sigma(l_{s0})$: standard deviation of the lead time from supplier to DC (in case of no order splitting);
 $\sigma(l_{0n})$: standard deviation of the lead time from DC to retailer n (in case of no order splitting);
 $\sigma(t_{sn})$: standard deviation of the in transit time from supplier to retailer n ;
 $\sigma(t_{s0})$: standard deviation of the in transit time from supplier to DC;
 $\sigma(t_{0n})$: standard deviation of the in transit time from DC to retailer n ;
 $\sigma(d_n)$: standard deviation of the daily demand at retailer n ;
 $\sigma(d_0)$: standard deviation of the daily demand at DC;
 $\sigma(LTD_{s0i})$: standard deviation of the lead time demand from supplier to DC for the i^{th} proportion of Q_n (in case of order splitting);
 $\sigma(LTD_{sni})$: standard deviation of the lead time demand from supplier to retailer n for the i^{th} proportion of Q_n (in case of order splitting);
 $\sigma(LTD_{sn})$: standard deviation of the lead time demand from supplier to retailer n (in case of no order splitting);
 $\sigma(LTD_{s0})$: standard deviation of the lead time from supplier to DC (in case of no order splitting);
 $\sigma(LTD_{0n})$: standard deviation of the lead time from DC to retailer n (in case of no order splitting);
 CS : cycle stock;
 IT : in-transit stock;
 SS : safety stock;
 β : service level;
 ES_n : expected number of shortages per cycle at retailer n in case of no order splitting;

Notational Terms

ES_0 : expected number of shortages per cycle at DC in case of no order splitting;

ES_n^{OS} : expected number of shortages per cycle at retailer n in case of order splitting;

ES_0^{OS} : expected number of shortages per cycle at DC in case of order splitting.

1 Introduction

1.1 Scope of the Research

An essential aspect of modern logistic concepts is the question how to deal with demand and lead time uncertainties. Risk pooling strategies are practical ways of dealing with these uncertainties. To overbear the risks of uncertainty in lead-time, order splitting has been suggested by some researchers. Order splitting (OS) is splitting a single order in a number of subsequent deliveries in the same reorder cycle (Janssen et al., 2000). In a typical inventory control policy, an order quantity is placed with a specific vendor whenever the inventory level drops to the reorder point (continuous review system) or whenever the inventory is reviewed periodically (the periodic review system). It is generally assumed that the whole order quantity is received in a single delivery from the supplier(s) in each order cycle. However, it is possible that multiple deliveries can be arranged with the supplier(s) so that portions of the order quantity arrive at the receiving point at different times. Apparently, the benefit associated with this approach is the reduction in the inventory costs and simultaneously, achieving better service. By receiving smaller quantities at the right times, buyers can obtain inventory-related savings to a considerable degree. The Japanese manufacturing philosophy also provides most of the motivation toward this frequent-delivery approach (Chiang and Chiang, 1996).

On the other hand, these multiple deliveries can be done from one supplier (single sourcing) and not necessarily from multiple suppliers (multiple sourcing). The decision on the number of suppliers has been discussed extensively during the last few years. Although some companies try to supply their requirements from more than one supplier to reduce the risk of nonperformance, it is not still clear whether adopting more suppliers is cost-beneficial. It has been discussed that the benefits of single sourcing often outweigh that of multiple sourcing (Burke et al., 2007). Mishra and Tadikamalla (2006) provided

1 Introduction

a list of factors from the literature to show when the decision on single or multiple sourcing is favored.

Another risk pooling strategy is consolidated distribution (Cachon and Terwiesch, 2009) and is suggested as a way of dealing with demand uncertainty. It can also be called depot effect (Eppen and Schrage, 1981) or postponement. If the total demand for a number of market stores is known but the allocation of this total demand to each store is uncertain, we can benefit from Consolidated Distribution (CD) to reduce this uncertainty. Here, warehouses or retail stores place their orders on a consolidating/Distribution Center (DC) instead of directly ordering from supplier(s) and the DC, in turn, orders from the supplier(s). This postpones a decision in distribution and makes the company able to use more accurate information because of a shorter forecast period and an aggregate forecast, especially in industries with high demand uncertainty, and commits resources rather to demand than to a forecast (Oeser, 2010). A primary work on logistics postponement by Eppen and Schrage (1981) discusses whether to ship the orders directly from the supplier to the warehouses or send the aggregated demand of all warehouses to a distribution center as a joint ordering point and then, to each warehouse. The advantage of depotting is that final allocation decisions would not have to be made until more information is available and, thus, one should be able to reduce the probability of stock-outs in future periods (Eppen and Schrage, 1981).

Both of these two concepts (consolidated distribution and order splitting) have been sufficiently addressed by researchers in each area. What lacks in the literature as well as in practice is the investigation of the possibility of integrating these two concepts and their simultaneous implementation. van Hoek (2001) and Boone et al. (2007) clearly call for linking postponement with other supply chain concepts. Oeser (2010) also criticizes the lack of research on combining a specific risk pooling method with other ones. In this research, we integrate these two risk pooling strategies and examine how their interaction influences the total logistics cost.

1.2 Problem Description and Research Questions

In this research work, we consider the impact of order splitting at the multi-echelon level, where there are retailers who place their orders on a single supplier through a DC. Although splitting the order of a single buyer may result

1.2 Problem Description and Research Questions

in extra costs, splitting the aggregated order of multiple buyers may bring benefits to the system. Order splitting in a multi-echelon system can have the same impact as the other two risk pooling strategies, i.e. consolidated distribution or postponement, from the point of view that delaying the delivery of the second or next shipments can result in obtaining more customer information about postponed shipments. This could be discussed, for example, under the title “partial postponement”, which has been argued, although from other viewpoints, by Graman (1999; 2010).

Till 2006, research mainly investigated the trade-off between ordering cost and inventory cost when dealing with the order splitting problem. This stream of research indicates that splitting orders can lead to savings in inventory holding cost that outweigh the incremental ordering cost. Thomas and Tyworth (2006) criticized the literature on order-splitting, stating that the transportation and ordering costs are ignored or at least underestimated. They discussed that shipping costs increase disproportionately as the size of the shipment decreases, which means that order splitting may increase transportation costs substantially. In their work in 2007 (Thomas and Tyworth, 2007), they concluded that managers should consider order splitting, at best, in the case of high lead-time volatility, high demand rates, high service levels, high inventory carrying cost factors, high unit values and low incremental transportation and ordering costs. In spite of the importance of transportation cost in order splitting, it seems that most research works after Thomas and Tyworth (2006) have still either ignored or underestimated the consideration of this element in the total logistic cost.

In this work, we discuss that a purchasing cost, which is based on a quantity discount structure, represents a potentially important component upon the development of a supplier-DC-retailers system. There is other order splitting research that has included this cost in mathematical models (Ganeshan et al., 1999; Tyworth and Ruiz-Torres, 2000; Mishra and Tadikamalla, 2006). However, in our work, the purchasing price follows a stepwise function, meaning that the increase in order quantity results in lower purchasing cost for the buyer. We believe that quantity discount is an important element in order splitting. In practice, the price of an item and its ordered quantity are negatively correlated. Therefore, when an order is split and supplied via multiple vendors, the procurement price will increase. This is another shortcoming in the research related to order splitting. We discuss that in the particular case of

1 Introduction

having a DC, i.e. when the orders are aggregated by the DC, the whole order quantity and consequently, the order quantity of each retailer can benefit from quantity discounts.

As discussed above, we also consider another important logistics cost element (transportation cost) in our model. Larger orders may allow the vendor to capture transportation discounts currently unavailable to him. Therefore, even if the order quantity of a DC is split, it still takes advantage of consolidated orders, compared to order splitting models when the supplier directly sends the order to the retailers.

This consolidated demand has other advantages for supply chain parties. First, larger individual order means the vendor will need to process fewer orders per year from the customer. Thus, with larger orders the vendor should be able to reduce his yearly order processing costs. Second, and potentially even more important, are the manufacturing cost savings made possible by larger customer orders. This is especially true for the vendor who produces the item himself. Larger orders, if produced to order, will mean longer production runs and fewer manufacturing set-ups per year. This can be reflected in the purchasing price of the customer. However, inventory should be held both at DC and retailers' shelves. Finally, larger individual orders will cause a change in the current pattern of orders placed throughout the year. This will mean a shift in both the magnitude and timing of order payments from the buyer. Hopefully, the vendor will then find he has the use of more the buyer's money, earlier in the year. This may be very important to the vendor, depending upon the size of his particular opportunity cost of capital (Monahan, 1984).

We also assume that a business implements order splitting over time, and not over suppliers. That means, there is only one supplier and the order is split and delivered at different points of time. The case of order splitting via a single supplier has been studied by Mishra and Tadikamalla (2006), Hill (1996), and Chiang and Chiang (1996). Based on the work of Mishra and Tadikamalla (2006), we assume that many advantages of dual sourcing arise from order splitting rather than actually using two suppliers. This assumption supports our approach in using order splitting between supplier and DC, i.e. downstream part of our supply chain where we want to take advantage of quantity discounts. According to Supplier Selection and Management Report (IOMA, 2002), reducing the supplier base has been the "top of the list" most effective practice for controlling costs during six consecutive years. Figure 1.1

1.2 Problem Description and Research Questions

shows an example of single sourcing.

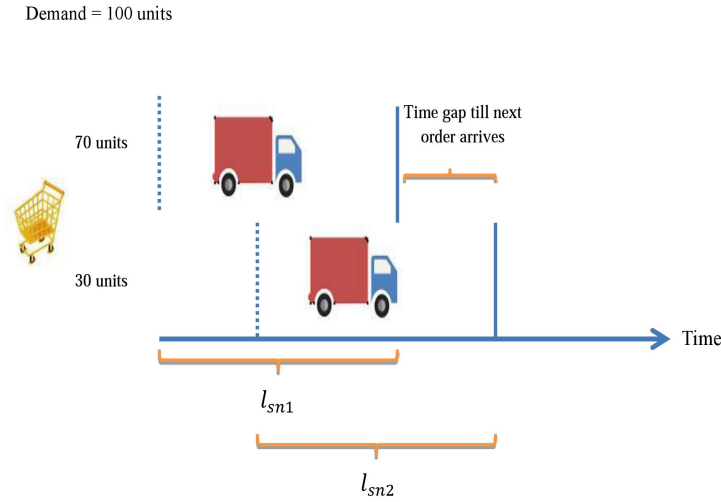

Figure 1.1: Order splitting over time

We believe that our research model is practical and mathematically simple. We have taken into consideration many advantages and disadvantages of consolidated distribution and order splitting. We moderate the disadvantages of one strategy through its integration with the other one.

In this research work, the application of order splitting before the decoupling point (here DC) in a multi-echelon supply chain will be investigated. We do not consider order splitting between DC and retailers. We assume that the demand of the retailers is pooled through the DC, and a single supplier feeds the DC.

The application of nonlinear purchasing and transportation cost functions is ignored in the previous research works. We believe that it has a great impact on the total cost of order splitting and, generally, the supply chain. Taking this approach into account, we move one step forward in comparison to the work of Thomas and Tyworth (2007) and discuss whether the total logistic cost of an order splitting model is lower than that of a non-order splitting model, in case transportation and purchasing price are nonlinearly related to order quantity. To this aim, the first research question is established as following:

1. *How high is the total cost of a Direct Shipping system where the order quantity is split (DSOS model) compared to a Direct Shipping non-order splitting system (DS model), when transportation and purchasing cost functions are nonlinear and there is a single supplier?*

1 Introduction

Moreover, when purchasing and transportation costs are nonlinear, the consolidation of retailers' orders at DC creates larger order quantities which results in lower purchasing and transportation costs. Therefore, we intend to answer the following research question as well:

2. *How high is the total cost of a system where the retailers' order quantities are consolidated through a DC (CD model) compared to a Direct Shipping non-order splitting system where the retailers' order quantities are directly placed on the supplier (DS model), when transportation and purchasing cost functions are nonlinear and there is a single supplier?*

In the next step, we look forward to see how the integration of order splitting and consolidated distribution affects the total logistic cost. Therefore, we present our third research question as following:

3. *How high is the total cost of a system where the retailers' order quantities are consolidated through a DC and the order quantity between supplier and DC is split (CDOS model), compared to a Direct Shipping non-order splitting system where the retailers' order quantities are directly placed on the supplier (DS model), when transportation and purchasing cost functions are nonlinear and there is a single supplier?*

1.3 Structure of the Research Work

In chapter 2, a brief literature review on consolidated distribution will be presented. Next, order splitting literature is reviewed and the shortcomings of the research in this area are highlighted. This is done through comparison of the research stream before and after the work of Thomas and Tyworth (2006) to see if their criticism has been dealt with in later research works.

In chapter 3, the mathematical models for the determination of the Total Annual Cost (TAC) are presented. We also discuss the solutions to the mathematical model. We consider the trade-offs between purchasing, transportation, ordering, cycle, safety, and in-transit inventory costs. We firstly model the total cost of Direct Shipping system (DS model). Then, we consider the total cost of a Direct Shipping Order Splitting system (DSOS model) and a Consolidated Distribution system (CD model), separately. In the fourth model, we integrate Consolidated Distribution and Order Splitting strategies to consider the impact of their integration on a supply chain (CDOS model).

1.3 Structure of the Research Work

Chapter 4 provides the numerical experiments by examining the mathematical models of chapter 3 using the softwares “*Excel 2010*” and “*Mathematica 10.0*”. A detailed sensitivity analysis on how important input parameters influence the results of the models is conducted. These results are, then, presented. Later in chapter 5, we analyze these results and present the main findings and discussions of our research work. The chapter ends with the limitations of the work and future research directions.

2 Review of the Related Research

2.1 Risk Pooling

Pooling is a resource management term that refers to the grouping together of resources for the purposes of maximizing advantage and/or minimizing risk to the users. The term is used in many disciplines. It is often central to many operational strategies and an important concept in Logistics and Supply Chain Management (L&SCM) (Oeser, 2010). In L&SCM, it takes the form of using a centralized system with aggregated ordering via a centralized facility, instead of a decentralized system with separate ordering. Therefore, it is defined as “consolidating individual variabilities of demand and/or lead time in order to reduce the total variability they form and thus, uncertainty and risk (the possibility of not achieving business objectives)” (Oeser, 2010, p. 12). The underlying idea of risk pooling is to mitigate the uncertainty and minimize the total cost while maintaining a high service level (Cai and Du, 2009).

Risk pooling is widely used in various industries such as insurance companies, engineering systems and financial institutions, etc. (Cai and Du, 2009). However, a survey of 102 German manufacturing and trading companies by Oeser (2010) shows that risk pooling strategies are known fairly well in Germany but despite their potential benefits, they are not extensively implemented. Based on a comprehensive search in the literature, Oeser (2010) concludes that apart from inventory pooling (IP), risk pooling can also be achieved by: Capacity Pooling (CP), Central Ordering (CO), Component Commonality (CC), Virtual Pooling (VP), Postponement (PM), Product Pooling (PP), Product Substitution (PS), Transshipments (TS), and Order Splitting (OS). He categorizes these risk pooling methods into two groups. The first types are those strategies which pool demand, and include the first eight strategies mentioned above. The last two strategies are categorized as lead time pooling strategies. Table 2.1 represents this categorization.

2 Review of the Related Research

Table 2.1: Risk pooling methods' building blocks (adopted from Oeser (2010))

Building blocks	CP	CO	CC	IP	VP	PM	PP	PS	TS	OS
Demand pooling	1	1	1	1	1	1	1	1	0	0
Lead time pooling	0	0	0	0	0	0	0	0	1	1

One of the strategies categorized by Oeser (2010) is central ordering. He also calls it as “consolidated distribution”, “risk pooling over the outside supplier lead time”, or “warehouse risk pooling”. We believe that not all these titles can be applied interchangeably. For example, scenario 4 in the work of Munson and Hu (2010) indicates an approach in which the Centralized Purchasing Office (CPO) purchases the items for all retailers, but the items are directly shipped to retailers and not to the DC. This can be called central ordering. At the same time, Munson and Hu (2010)'s third scenario represents the case where purchasing and distribution/warehousing are done by a DC. Cachon and Terwiesch (2009) call this as “consolidated distribution”. Generally, we can call consolidated distribution as one type of centralized ordering.

This research considers two strategies of Oeser (2010) and discusses them in detail. We choose a strategy from lead time pooling category, which is order splitting, and one from demand pooling category, and that is Consolidated Distribution. The aim is to comprehensively discover the advantages and disadvantages of order splitting, and see if its shortcomings, argued by e.g. Thomas and Tyworth (2006), can be covered through integration with another strategy. We believe that consolidated distribution can accomplish this task.

Figure 2.1 represents the trend in risk pooling research till 2009. It is clear that there has been an increasing interest in this area since its introduction. In addition, it indicates that both consolidated distribution (centralized ordering in this figure) and order splitting are among those strategies with fewer research works in comparison to other strategies. Therefore, doing more research on them can explore new directions on these research streams.

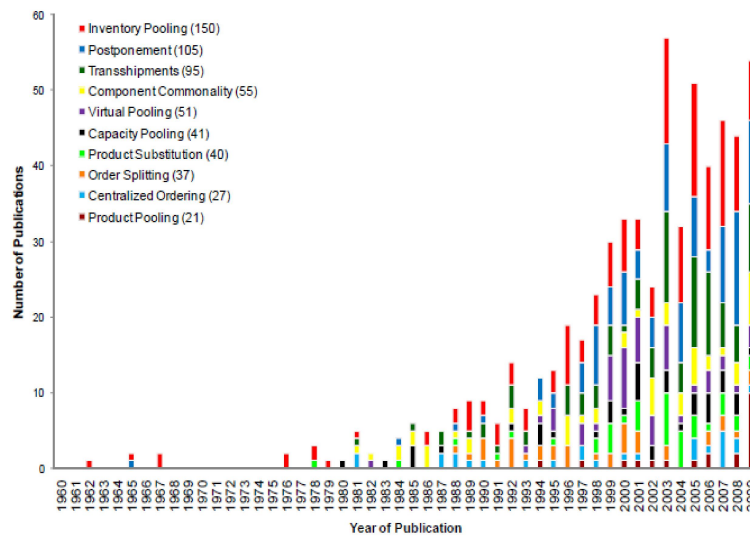

Figure 2.1: Risk pooling research since its introduction (adopted from Oeser (2010))

2.2 Consolidated Distribution

In the consolidated distribution, the separate lead times between the supplier and the retailers in the direct shipping system are pooled to a single lead time between the supplier and the DC. It means that forecast demands are pooled over the outside supplier lead time. Consolidated distribution creates larger common orders for multiple locations and this, in turn, makes more frequent shipments economically possible between the suppliers and the DC and the DC and the retailers. Therefore, this may decrease lead time uncertainty despite the additional lead time from the DC to the various retailers (Oeser, 2010). If the lead time before the DC is much longer than the lead time after the DC, consolidated distribution is most effective (Cachon and Terwiesch, 2009).

Eppen and Schrage (1981) investigate centralized ordering policies in a periodic-review base-stock multi-echelon, multi-period system for steel industry with independent normally distributed random demands and identical costs of holding and backordering at N warehouses. They derive expressions for the inventory at each warehouse. The objective is to optimize the total cost of the system by exploring the optimal value of the system-wide inventory position as the decision variable.

Schwarz (1989) compares two inventory systems. In the first system, the products are directly shipped from the manufacturer to retailers, but in the

2 Review of the Related Research

second system, they are shipped to a central warehouse which feeds the retailers. Upon receipt of the shipment to the warehouse, the system order is allocated to retailers. The warehouse holds no inventory and acts as a cross-docking facility. He assumes order-up-to level policy and only models the inventory costs. In case the in-transit inventory can somehow be avoided, the risk pooling in system 2 has considerable value, otherwise its overall value of risk pooling is sharply reduced. He also concludes that if the allocation and repackaging time at the warehouse is small and the proportion of transport time of supplier-warehouse to warehouse-retailers is considerably larger, then, system 2 outperforms system 1.

Erkip et al. (1990) study a depot-warehouse system where the demands both across warehouses and in time (demand of a warehouse for two successive periods) are correlated. The effect of this correlation on safety stock is examined. Similar to Schwarz (1989), they assume that the depot holds no inventory and acts as an order consolidating facility. Their numerical evaluation shows that the effect of correlations is highly significant which results in larger amounts of safety stock.

Gürbüz et al. (2007) consider a coordinated replenishment policy where there is one warehouse and there are N identical retailers. The warehouse plays the role of a cross-docking terminal with no inventory in which upon the arrival of the shipments at the warehouse, they are allocated to the retailers. The warehouse has full access to the system information of the retailers' inventory. They include holding, backorder, ordering, and shipment cost in their model. They also propose a new policy called hybrid policy. They explain this as a mixture of the traditional echelon policy and a special type of can-order policy. Under this policy, the warehouse monitors the inventory position of all retailers, and places an order at the outside supplier to raise every retailer's inventory position to an order-up-to level S_H , whenever any retailer's inventory position reaches s_H , where $s_H < S_H$, or the total demand at all the retailers reaches Q_H . The numerical results suggest that this policy provides significant improvement over the echelon-based replenishment policies, and the installation-based policy performs as good as the hybrid policy when the transportation costs are not included.

Munson and Hu (2010) provide methods to compute optimal order quantities and total purchasing and inventory costs where the purchasing quantity benefits from quantity discount pricing. They propose four strategies for

purchasing: complete decentralization, centralized pricing with decentralized purchasing, centralized purchasing with local distribution, and centralized purchasing and warehousing. In the fourth strategy (centralized purchasing and warehousing), a central warehouse buys from a supplier and delivers to local sites. The central warehouse may keep the items for some time until the local sites ask for replenishment. The authors conclude that with centralized purchasing and warehousing, retailers or local warehouses can benefit from discounted purchase price while holding little inventory.

Cachon and Terwiesch (2009) categorize risk pooling strategies as location, virtual, product, capacity, and lead time risk pooling. They further discuss consolidated distribution and delayed differentiation as two strategies to achieve lead time pooling. Location and product pooling's limitations include farther distance between inventory and customers, and potential degradation of product functionality, respectively. On the other hand, lead time pooling shortens the lead time to customers while allowing to benefit from location pooling. As the stocking point is close to all customers, lead time would be decreased and final allocation of demand is delayed till the last moment, and the inventory of any customer can be replenished from this stocking point which in turn results in location uncertainty reduction.

In contrast to location pooling which just creates the DC as the centralized inventory location and fulfills the demands of the customers directly from the DC (it, thereby, eliminates retail stores, and therefore, prevents customers from physically seeing a product before purchase) (Cachon and Terwiesch, 2009), consolidated distribution allows the retailer stores to keep inventory. In the consolidated distribution, retailers are served by a central DC, which is close to retailers, instead of the supplier. This reduces the lead time to replenish their stores which in turn reduces drastically their storage capacity and inventory. One may assume that, like in Eppen and Schrage (1981), the DC does not hold inventory, or may extend their work by assuming that the DC holds inventory, as they suggest.

As the main topic of this research is order splitting, we focus on the literature around this subject. We are not going to review the extensive literature on consolidation distribution as it is broadly discussed in Oeser (2010) and other research works (e.g. Cachon and Terwiesch 2009). However, the interaction between these two strategies and the advantages or disadvantages that this integration brings to a supply chain will be later discussed.

2.3 Order Splitting

2.3.1 Literature Review before 2006

Many research works have been trying to analyze the effects of different strategies to control lead time, as variability in lead time between successive stages has a great influence on supply chain coordination (Ryu and Lee, 2003). Oeser's comprehensive categorization of risk pooling methods also involves order splitting. In his research, order splitting is discussed as a method to pool/reduce lead time uncertainty.

Order splitting is at its infancy. Hill defines order splitting as "splitting a replenishment order between two or more suppliers rather than rely on one supplier to meet it" (Hill, 1996, p. 53). Chiang and Chiang (1996) clarify that order splitting is the issue of arranging the arrival of multiple deliveries with the supplier so that portions of the order quantity arrive at the receiving point at different times. A universal definition of order splitting is provided by Janssen et al. who define order splitting as "splitting a single order in a number of subsequent (equally sized) deliveries in the same reorder cycle (Janssen et al., 2000, p. 1136)". However, the only drawback of this definition is that they only assume equally sized deliveries.

The decision on the number of suppliers has been extensively discussed during the last few years. While some companies try to supply their requirements from more than one supplier to reduce the risk of nonperformance, it is not still clear whether adopting more suppliers is cost-beneficial. It is discussed that, in many cases, using multiple suppliers reduces inventory and distribution system costs. However, many companies are moving from having many suppliers to largely rely on a single supplier (Ganeshan, 1999). Researchers (Mohr and Spekman, 1994; Burke et al., 2007) assert that the benefits of single sourcing often outweigh that of multiple sourcing. According to Supplier Selection and Management Report (IOMA, 2002), reducing the supplier base has been the "top of the list" most effective practice for controlling costs during six consecutive years. Mishra and Tadikamalla (2006) provided a list of factors from the literature to show when the decision on single or multiple sourcing is favored (Table 2.2).

Table 2.2: Factors influencing the decision on single and multiple sourcing (adopted from Mishra and Tadikamalla (2006))

Single sourcing is favored	Multiple sourcing is favored
<u>Cost:</u>	
<ul style="list-style-type: none"> - High cost of close cooperation; - Higher trust between supplier and buyer; - Economies of scale and learning curve advantages for supplier; - Lower cost due to quantity discounts; - High setup/order cost. 	<ul style="list-style-type: none"> - Switching costs remain low; - No supplier has unfair advantage in negotiations; - Low cost and high performance through competitive bidding.
<u>Production:</u>	
<ul style="list-style-type: none"> - Better quality due to long-term relationship and associated investments; - Better understanding of product and process specifications; - Quality control easier due to one source of variation; - Facilitates Just-in-Time; - Lower uncertainty of demand for supplier. 	<ul style="list-style-type: none"> - High risk of disruption of supply due to fire, strike, natural disaster, financial insolvency, etc.
<u>Competitiveness:</u>	
<ul style="list-style-type: none"> - Superior quality improves competitiveness; - Poor quality of a supplier can reduce market share and competitiveness. 	<ul style="list-style-type: none"> - Access to new and wider variety of technology from among which commitment can be made to the most suitable technology.

Since its introduction, it seems that adequate research on order splitting has not been completed. A reason could be that some research results (e.g. Thomas and Tyworth 2007) have questioned the usefulness of order splitting or claimed that order splitting is advantageous under certain limited conditions. An overview of order splitting literature can also be found in Thomas and Tyworth (2006).

Sculli and Wu (1981) are the first authors who publish a paper on order splitting and investigate its impact on Lead Time Demand (LTD) and consequently, safety stock. The lead time and demand are both assumed to be stochastic, where lead time is normally distributed. Given that replenishment orders are placed at the same time, they indicate that simultaneous use of two suppliers results in lower reorder level or safety stock.

2 Review of the Related Research

Sculli and Shum (1990) extend order splitting to the case of N suppliers, where orders on these suppliers are placed at the same time. Their results show that there is a negative correlation between safety stock and shortage cost, and number of suppliers. It means that placing several replenishment orders for a single item simultaneously with multiple suppliers will reduce the buffer stock and average shortage for a given level of protection against stock-out during lead-time demand.

The case of constant demand with uniform or exponential lead time is considered by Ramasesh et al. (1991). The order quantity is equally split between two suppliers and placed simultaneously. The total cost consists of ordering and inventory holding costs. Using numerical search to find the optimal solutions, they reach the following conclusions:

- If ordering cost is relatively low, the savings from dual sourcing, because of decrease in inventory holding and backordering costs, outweigh the increase in ordering cost;
- Dual sourcing would be more beneficial as the lead time variability increases;
- Exponentially distributed lead times offer more savings when compared to uniformly distributed lead times. They conclude that dual sourcing may suggest more benefits for skewed and long-tailed lead time distributions.

Hong and Hayya (1992) consider two Just-In-Time models, one with one supplier and the other with multiple suppliers, in which the order quantity is split. The models are deterministic and include the aggregate ordering cost (transportation, inspection, and other related ordering costs) and inventory holding cost. Mathematical procedures are proposed to find the optimal selection of suppliers and the size of the split orders for both models.

Lau and Zhao (1993) derive expressions for cycle stock, safety stock and shortage cost in order splitting. They provide procedures for any stochastic lead time and demand. The total cost function consists of ordering cost, cycle, safety, and shortage costs for the two supplier case. They conclude that in an order splitting system:

- The effect of shortage cost reduction in order splitting is comparatively small;

- The major advantage is due to the reduction in cycle stock;
- When the lead time of the second supplier is suitably larger than the lead time of the first supplier, order splitting is more advantageous;
- The optimal proportion of split portion depends on the difference between the lead times of the suppliers.

Lau and Lau (1994) present a model and solution procedure for the case of two suppliers where one offers lower prices and the other supplier has shorter lead time. The demand is deterministic but the lead time is stochastic. The total cost function consists of purchasing, ordering, safety stock, cycle stock, and shortage costs. Their results indicate that the decision to split the order quantity and the optimal proportion of the split quantity depends on different parameters, e.g. unit shortage cost, holding cost, standard deviation of lead time, etc. They also conclude that when the inventory parameters have intermediate values, it is worth to split the order quantity for two suppliers.

It seems that Gupta and Kini (1995), Hill (1996), and Chiang and Chiang (1996) are the first authors who examined order splitting with one supplier. Gupta and Kini (1995) develop a model to integrate JIT and PQD (Price-Quantity Discount). Using their proposed model, companies can place orders in large quantities (PQD structure), while receiving them in JIT format (small lot sizes). Ordering cost, inventory holding cost, transportation cost, and purchasing cost comprise the total cost model. Although the purchasing price follows a step-wise function, the transportation cost is linear. The model allows the buyer to decide how much to purchase and how many shipments should be placed per order. Through their numerical experiments one may observe that the total cost per year decreases as the order quantity and number of deliveries both increase.

Hill (1996) considers a Poisson or deterministic demand process, and a general lead time distribution for placing n orders on a single supplier. His model includes only the inventory holding and back-order/lost sales costs. The results show that:

- Order splitting has always lower stock levels than non-split model.
- Compared to order splitting through different and identical suppliers, order splitting through single sourcing (placing order on one supplier at different points of time) will result in lower operating costs.

2 Review of the Related Research

- Assuming the same order quantity and service level, he suggests (but not proves) that increasing the number of split portions (i.e. making smaller orders) of a single supplier reduces the average stock level.

Assuming normally distributed demand and constant lead time, Chiang and Chiang (1996) calculate the total cost of ordering, inventory carrying (cycle and safety stock), and shortage for two delivery order splitting. They derive expressions for cycle stock and show that splitting the order in multiple deliveries can significantly reduce inventory carrying cost for independent-demand items.

Using a level-crossing methodology, Mohebbi and Posner (1998) analyze sole sourcing versus dual sourcing model where there is lost sales cost. The demand and lead time have, respectively, compound Poisson and exponential distributions. The cost model consists of purchasing, ordering, inventory holding, and shortage costs. Their results supports the benefits of dual sourcing over single sourcing when the lead time is stochastic.

Ganeshan et al. (1999) provide a broader order splitting model which includes purchasing, non-linear transportation, ordering, and inventory (including in-transit inventory) costs. The demand is normally distributed and lead time may have any distribution. In their model, the second supplier is an unreliable supplier having longer lead time mean and variance, which offers lower purchasing price. The objective is to find whether order splitting is more advantageous than sole sourcing, and if yes, the amount of discount and split proportion of the second supplier. Their conclusion is that order splitting is beneficial if the price discount of the second supplier is sufficient enough to cover the increase in other costs.

The mathematical model of Sedarage et al. (1999) considers a N -supplier system with random lead time and demand which consists of ordering cost, purchasing cost, inventory holding cost, and shortage cost. The purchasing price for each supplier is different. Contrary to some other previous research works, their numerical experiments indicate that there is an optimal number of suppliers, in case the order splitting is a worthwhile policy. A counter-intuitive finding of thier work is that, it may be economical to place an order with suppliers having higher lead time mean and standard deviation and higher purchasing price.

Janssen et al. (2000) evaluate order splitting from the suppliers' point of view and call it delivery splitting in which the order quantity is shipped in equally

sized and equally spaced deliveries. In their work, demand has a compound Poisson distribution while lead time is deterministic. The problem is to find the optimal values of order quantity, the reorder point, the time between the shipments, and the amount of shipment. The objective function is the sum of ordering, holding, and transportation costs subject to a service level constraint. Transportation cost is proportional to the number of deliveries. Their results indicate that the profitability of delivery splitting strongly depends on the input parameters.

Tyworth and Ruiz-Torres (2000) compare dual sourcing with single sourcing. The total annual cost consists of purchasing, transportation, ordering, cycle and safety stock holding, and back-order costs. The purchasing price may be different for different suppliers but it is not a function of order quantity. The demand is constant while the lead time is exponentially distributed. Their results show the important role of transportation cost in dual sourcing. They argue that high annual demands, poor lead time performances, high supplier prices, and short supply lines best fits to order splitting.

Ghodsypour and O'Brien (2001) developed a mixed integer non-linear programming model to solve the multiple sourcing, multiple criteria and capacity constraint problem. The total cost comprises of purchasing, inventory holding, transportation, and ordering costs. The purchasing price does not follow a quantity discount scheme. The proposed algorithm for solving the model is illustrated using a numerical example.

Kelle and Miller (2001) analyze the optimal rate of split proportion if the objective is to minimize stock-out risk. The assumption is that ordering, purchasing, and transportation costs are the same for both suppliers, so they exclude these cost elements from their model. They consider both constant and random demand, while both suppliers have lead times with different characteristics. They show that uneven split proportions reduce the stock-out risk compared to even split proportions. If order quantity is much larger than the expected lead time demand, the optimal split proportion in dual sourcing reduces stock-out risk for both suppliers.

Ryu and Lee (2003) examine a dual sourcing model with and without lead time reduction and stochastically determine lead time for each supplier. The demand is constant and lead time is exponentially distributed for both suppliers. They try to find out the optimal amount of reduction in lead time and determine the order quantity of each supplier as a result of this lead time

2 *Review of the Related Research*

reduction. The total cost function is the sum of inventory holding, shortage, and ordering costs. They find out that dual sourcing with lead time reduction results in significant savings in the expected total cost per unit time.

Instead of splitting the order quantity between different suppliers, Dullaert et al. (2005) extend the model of Ganeshan et al. (1999) by allocating the order, which is placed on a single supplier, to different transport modes. This means splitting over transport alternatives. The total cost includes ordering, transportation, cycle stock, safety stock and in-transit stock costs. They make two assumptions: first, order quantities are a linear combination of total capacities of different transport modes, implying that the capacity of a transport alternative is fully utilized if it is selected. Second, instead of effective lead time for calculating safety stock, they use the lead time of the fastest transport alternative (shortest average lead time). Both lead time and demand are random variables. They use an Evolutionary Algorithm to solve the problem. This research work is not mentioned in the literature review by Thomas and Tyworth (2006).

A review of the main logistics cost elements which are included in the mathematical models of previous research works is summarized in Table 2.3.

2.3.2 Review of post 2006 Literature

In the previous section, we tried to provide an overview of order splitting literature until 2006. A comprehensive overview of order splitting literature can also be found in Thomas and Tyworth (2006).

Reviewing the literature on order splitting, Thomas and Tyworth (2006) criticized previous research works arguing that the literature has mostly ignored or underestimated the ordering and transportation costs. In spite of the importance of transportation cost in order splitting, it seems that even most studies after Thomas and Tyworth have not appropriately applied this cost element in their work. Columns 2-5 in Table 2.4 represent the inclusion of the main logistics cost elements in developing order splitting mathematical models since the work of Thomas and Tyworth (2006). Although we do not claim that this list is exhaustive, it still affirms the criticism by these authors. It should be noticed that there may be other costs included in the analytical models of these papers. However, we just mentioned the availability of the main conventional logistics cost elements in order to see if transportation cost

Table 2.3: The main logistic cost elements in the literature before 2006

Authors	Inventory holding cost	Purchasing cost		Ordering cost	Transportation cost	
		Without quantity discount	With quantity discount		Linear	Non-linear
Sculli and Wu (1981)	✓					
Sculli and Shum (1990)	✓					
Ramasesh et al. (1991)	✓			✓		
Hong and Hayya (1992)	✓			✓	✓	
Lau and Zhao (1993)	✓			✓		
Lau and Lau (1994)	✓	✓		✓		
Gupta and Kini (1995)	✓		✓	✓	✓	
Hill (1996)	✓					
Chiang and Chiang (1996)	✓			✓		
Mohebbi and Posner (1998)	✓	✓		✓		
Ganeshan et al. (1999)	✓	✓		✓		✓
Ganeshan (1999)	✓			✓		✓
Sedarage et al. (1999)	✓	✓		✓		
Janssen et al. (2000)	✓			✓	✓	
Tyworth and Ruiz-Torres (2000)	✓	✓		✓		✓
Ghodsypour and O'Brien (2001)	✓	✓		✓	✓	
Ryu and Lee (2003)	✓			✓		
Dullaert et al. (2005)	✓			✓	✓	

2 *Review of the Related Research*

element has been included in these models.

In this work, we consider another important element, quantity discount, in our cost model. We believe that quantity discount is an important element in order splitting cost models. In practice, the price of an item and its ordered quantity are negatively correlated. Therefore, when an order is split, its procurement price may increase, especially if it is supplied from multiple sellers. This is another shortcoming in the related research works.

Mishra and Tadikamalla (2006) show that many of the benefits of dual sourcing come from order splitting rather than using two suppliers. After the order for the first portion of the order quantity is sent to a supplier, the order for the subsequent order quantities are placed on the same supplier, but with a time delay (scheduled-release). The demand is constant but the lead time is stochastic with gamma distribution. The total cost comprises of procurement, ordering, safety and cycle stock, and shortage costs. When a supplier has low standard deviation of lead time and a competitive price, and also in cases where dual sourcing is considered, scheduled-release is beneficial. This is comparable to former research works in which the second supplier has a cheaper price but a worse lead time performance.

Qi (2007) considers two logistic and supply chain topics in a single manufacturer, multiple suppliers system: multiple sourcing, and the integration of marketing and operations. For multiple sourcing, he examines the case where suppliers have limited capacity. He assumes that market demand is determined by its selling price. There is a fixed transportation cost for each non-zero order. The objective is to find the optimal order quantity for each supplier. The total maximization profit function of the manufacturer consists of selling income minus the production cost of the manufacturer and the costs incurred with suppliers (purchasing, transportation and ordering costs). It seems that Qi has not included inventory cost. He also extends his basic model to the case where there are quantity discounts for buying prices from suppliers. Using a heuristic algorithm and a dynamic programming algorithm, he concludes that: first, a conservative production plan is favored if the sourcing information is not available, and second, an aggressive production plan is preferred if the market demand information is unknown and there are enough suppliers.

In their paper in 2007, Thomas and Tyworth examine an order splitting model where both demand and lead time are random variables. However, they discuss that lead time of each shipment may not necessarily be independent.

Their total annual cost is the sum of ordering, holding (cycle, safety, and in-transit inventory), transportation, and shortage costs. They concluded that order splitting is beneficial only in case of high lead time volatility, demand rates, service levels, carrying costs, and unit values and relatively low incremental transportation and ordering costs. They also discussed these issues in an international case study.

The work of Burke et al. (2007) focuses on supplier selection and quantity allocation to the selected suppliers. They develop an integrated model to investigate these two decisions and consider product prices, supplier costs, supplier reliabilities, supplier capacities, manufacturing inventory costs, and manufacturer diversification benefits in making decisions related to supplier selection and quantity allocation. There is uncertainty from both supply and demand side and the suppliers have capacity limits. The model includes inventory, purchasing, and shortage parameters. They have assumed that fixed ordering cost is zero as the orders are placed online. Their results show that single sourcing is beneficial when supplier capacities are large compared to the product demand and when there is no benefit from diversification. Otherwise, multiple sourcing is an optimal choice.

Burke et al. (2008) consider the case where a CPO (Central Purchasing Organization) aggregates the demands of retailers and places the order on suppliers. The problem is to identify what amount of order quantity should be provided by different suppliers who have capacity limitations and offer different quantity discount schemes (linear, incremental and all-units). The pricing scheme of each supplier also includes the logistics/transportation cost. They have assumed that fixed ordering cost is zero for the buying firm. If the suppliers have enough capacity to individually supply the total order quantity, single sourcing from the supplier with the least price is the optimal choice, otherwise the decision would be complex. For the latter case, they propose heuristics to solve the problem with good quality. When suppliers have capacity constraints, at most one selected supplier will receive an order quantity that is less than its capacity for linear and incremental discount schemes. Generally, the proposed heuristic provides stronger solutions using incremental discount scheme.

Sajadieh and Eshghi (2009) examine a dual sourcing model where the lead time and the purchase price are dependent on the order quantity. The objective is to find the optimal reorder point, order quantity and split proportion. In

2 Review of the Related Research

their work, demand is constant but lead time is a random variable. All-units quantity discount scheme is assumed. The total cost model consists of ordering, purchasing, inventory holding and shortage costs. Using a nonlinear mixed integer programming model, they conclude that:

- There is a positive and direct relationship between ordering batch size and the lead time. Ignoring this relation results in more than 50% underestimation of dual sourcing savings compared to single sourcing;
- When there is a quantity discount scheme, difference between dual sourcing and single sourcing is quite small;
- The optimal split proportion is not necessarily 50-50, given that there is a quantity discount scheme. Moreover, the split proportion is sensitive to discount breaking points;
- And, contrary to the results of Lau and Zhao (1993), when the suppliers' lead times are the same, order splitting is more attractive.

Chiang (2010) proposes an order splitting model with one supplier. This is an expedited shipment model with continuous-review policy (s, Q) . When the inventory falls below an expedited-up-to level R , the buyer asks the suppliers to ship part of the order quantity by fast transportation mode. The remaining portion of order quantity is then shipped by slow transportation mode. Both lead time and demand are stochastic. The total cost function is comprised of ordering, inventory holding, and shortage costs, given a pre-determined service level. The objective is to find how much of the outstanding order is expedited, and to find the optimal values of Q , s and R . The results indicate that the proposed model is attractive if service level is high, demand variability is large, the expediting cost is small, or the manufacturing lead time is long.

Focusing on the mathematical modeling of decision making process, Tsai and Wang (2010) apply a mixed integer programming method for order allocation problem with multiple products and multiple suppliers. A buyer receives orders from retailers and places their aggregate demand on different suppliers which have finite capacity. The model is comprised of purchasing and fixed ordering costs. This is done when there are quantity discount offers by the supplier. The model provides non-inferior solutions and analyzes tradeoffs among objectives.

Abginehchi and Farahani (2010) examine an order splitting model with N suppliers when the lead time is exponentially distributed and the demand is

constant. The objective is to find out the optimal number of suppliers to minimize total cost. Their total cost includes purchasing, inventory holding, ordering, and back-order costs. If there are two suppliers, they get similar results as in Ramasesh et al. (1991). The sensitivity analysis represents that, for every n :

- The increase in demand results in the increase in total cost and order quantity of supplier i ;
- The increase in ordering cost results in the increase in total cost and order quantity of supplier i ;
- The increase in inventory holding cost results in the increase in total cost, but the decrease of total order quantity;
- The increase in lead time means and/or variances results in the increase in total order quantity. However, it does not always increase total cost. In addition, it increases the optimal number of suppliers; and finally,
- When N increases, total order quantity increases, but total cost first decreases and then increases.

Cheng and Ye (2011) develop a two objective order splitting model to minimize cost and balance the production loads among the N selected suppliers when the lead time is deterministic. The first objective function minimizes the processing and ordering costs while the second one minimizes the deviation of production load rates distribution in the suppliers. It is not clear what their processing cost is comprised of. Their results indicate that the production load distribution among the selected suppliers is relatively balanced.

Developing a heuristic planning tool, Glock (2011) considers a supply chain consisting of one buyer and heterogeneous suppliers. The objective is to select the right suppliers and the right amount of quantity allocated to supplier i to minimize the total cost. All parameters, including lead time and demand, are deterministic and the production capacity of suppliers is limited. The total cost is the sum of the costs at the buyer and the vendors which includes inventory holding cost, ordering cost, and relationship management cost at the buyer, and inventory carrying cost, set-up cost, transportation cost, production cost at the vendor. He assumes a fixed transportation cost per delivery for each of the equal-sized batches per lot of supplier i . Shortages are not allowed. His

2 *Review of the Related Research*

proposed approach reduces the number of suppliers' combinations for solving the heuristic. This is, however, dependent on the total number of suppliers, the production rate of the suppliers, the relationship management costs, the location of the optimal solution, and the sequence in which the decision trees are evaluated.

Glock (2012) discusses the effect of learning on the suppliers' production process and consequently, the supplier selection (to order from a single or two suppliers) and order allocation decisions. He argues that learning process reduces the production costs and this, in turn, results in the decrease of sales price. All parameters, including lead time and demand, are deterministic and constant. The total cost function comprises of buyer and vendor costs. Buyer costs include inventory carrying cost, ordering cost, and relationship management cost (searching for suppliers, cost of qualifying and auditing suppliers). The vendors' costs comprise of inventory carrying cost, set-up cost, and labor cost. The learning effect is also included in the total system cost. The results indicate that the learning effect at the suppliers can be influenced by the supplier selection decision and dual- or multiple-sourcing may be worthwhile. Moreover, selecting both suppliers can be still beneficial if they have different learning effects.

Li and Amini (2012) consider multiple sourcing for new products where there is uncertainty and lack of information for demand data. The lead time is constant but demand is a random variable. The maximization function is total life cycle revenue minus total supply chain costs. Selling price, pipeline stock cost and safety stock cost are included in the model. They conclude that, in an uncertain environment, unit manufacturing cost is lower in single sourcing but multiple sourcing can be of higher overall profit for the supply chain.

A mixed integer non-linear programming is developed by Meena and Sarmah (2013) to consider multiple sourcing for different capacity, failure probability (due to man-made or natural disruptions) and quantity discounts for each supplier. They use genetic algorithm to solve the problem with the objective to determine the allocated order quantity to each supplier and minimize the total cost of the buyer. The total cost is comprised of purchasing cost, supplier management and expected total loss costs. The demand is known and constant and the suppliers have certain capacity. The results confirm the stronger effect of order quantity allocation over supplier's failure probability. They also show that management cost and loss per unit do not influence demand allocation

decision.

Silbermayr and Minner (2013) discuss interruptions in supply (due to machine breakdowns, material shortages, natural disasters, and labor strikes) as a reason for multiple sourcing. The distribution of demand is Poisson and lead time is exponentially distributed. The lead time is also extended to deterministic and gamma distributed lead times. Total cost consists of purchasing, inventory holding, and penalty costs (a lost sales and a back-order model). The results show the advantage of dual sourcing over single sourcing when the penalty costs are high and disruption periods are long.

Glock and Ries (2013) consider a multiple sourcing model under continuous review inventory policy and different delivery structures (simultaneous and sequential deliveries) with the objective of determining the size and timing of orders. Demand is normally distributed and lead time is deterministic but variable, depending on the lot size. The total cost is the sum of costs at the buyer and supplier facilities and consists of ordering, supplier handling and material receiving, inventory holding, and back-order costs at the buyer and inventory holding, set-up and transportation cost per lot size at the suppliers' facilities. They show that sequential delivery structure performs better than simultaneous delivery structure. This especially happens when the number of suppliers is high, receiving costs are low, fixed lead time is high in comparison to order quantity-dependent lead time, and finally, when inventory holding cost at the buyer is high, but it is low at the suppliers.

Abginehchi et al. (2013) propose a multiple sourcing mathematical model where both demand and lead time are stochastic. Their total cost includes ordering, purchasing, inventory holding, and shortage costs. They compare their model with that of Sedarage et al. (1999). They show that the difference between their and Sedarage et al.'s model increases by an increase in mean demand rate, decrease in ordering cost, increase in shortage cost, and increase in lead time mean and variance.

Four sourcing strategies are examined in the research work of Sajadieh and Thorstenson (2014) when the demand is constant and lead time is an exponentially distributed random variable. They consider single versus multiple sourcing throughout the supply chain where the costs of the buyer and suppliers are jointly or separately (cooperative and non-cooperative) optimized. The total cost function is the sum of back-order and ordering costs of the buyer, set-up cost of the suppliers and inventory holding cost at both buyer and supplier

2 *Review of the Related Research*

facilities. They find out that first, depending on the parameter values, dual sourcing has no advantage over single sourcing in many cases. Second, single sourcing with cooperative strategy often outperforms other three strategies. Third, the benefits of dual sourcing are realized at best when the majority of the total system costs arise from the buyer's side. And finally, single sourcing with cooperative strategy is in most cases beneficial when two non-identical suppliers have different lead time parameters.

Biçer (2015) considers the impact of tail heaviness of demand distribution on optimal dual sourcing policy using extreme value theory. The buyer orders from two suppliers, in which one is less expensive but less responsive, meaning that it requires the buyer to place the order well in advance and, the other supplier is more expensive but also more responsive and delivers faster. The maximization function includes the purchasing and inventory costs. The results indicate that the expected value of lost sales increase (lower fill rate), when the tail of the demand is heavier. Moreover, under heavy-tailed demand, high fill rate cost can be achieved if the cost of supplying from a responsive vendor is relatively low.

As it is shown in Table 2.4, there is no work considering all these main logistics cost elements simultaneously. In our models, we fill this gap.

2.4 Interaction of Consolidated Distribution and Order Splitting

Based on sections 2.2 and 2.3, both of these two concepts (consolidated distribution and order splitting) have been sufficiently addressed by researchers in each area. What lacks in the literature as well as practice is investigating the possibility of integrating these two concepts and their simultaneous implementation. Thus, the question may arise that “what is the interaction of consolidated distribution and order splitting?” In other words, “is there any benefit from the integration of these two strategies, or this is simply the summation of total cost of each strategy?”

van Hoek (2001) and Boone et al. (2007) clearly call for linking postponement with other supply chain concepts. Oeser (2010) also criticizes the lack of research on combining a specific risk pooling method with other ones. In this research, we integrate these two risk pooling strategies and examine how their

Table 2.4: The main logistic cost elements considered in the literature since 2006

Author(s)	Inventory holding cost	Purchasing cost		Ordering cost	Transportation cost	
		Without quantity discount	With quantity discount		Linear	Non-linear
Mishra and Tadikamalla (2006)	✓	✓		✓		
Qi (2007)		✓	✓	✓	✓	
Thomas and Tyworth (2007)	✓			✓		✓
Burke et al. (2007)	✓	✓				
Burke et al. (2008)			✓			
Sajadieh and Eshghi (2009)	✓		✓	✓	✓	
Chiang (2010)	✓			✓		
Tsai and Wang (2010)				✓		
Abginehchi and Farahani (2010)	✓	✓		✓		
Cheng and Ye (2011)				✓		
Glock (2011)	✓			✓		✓
Glock (2012)	✓			✓		
Li and Amimi (2012)	✓	✓				
Meena and Sarmah (2013)			✓			
Silbermayr and Minner (2013)	✓	✓				
Glock and Ries (2013)	✓			✓		✓
Abginehchi et al. (2013)	✓	✓		✓		
Sajadieh and Thorstenson (2014)	✓			✓		
Bicer (2015)	✓	✓				

2 Review of the Related Research

interaction influences the total logistics cost (Figure 2.2).

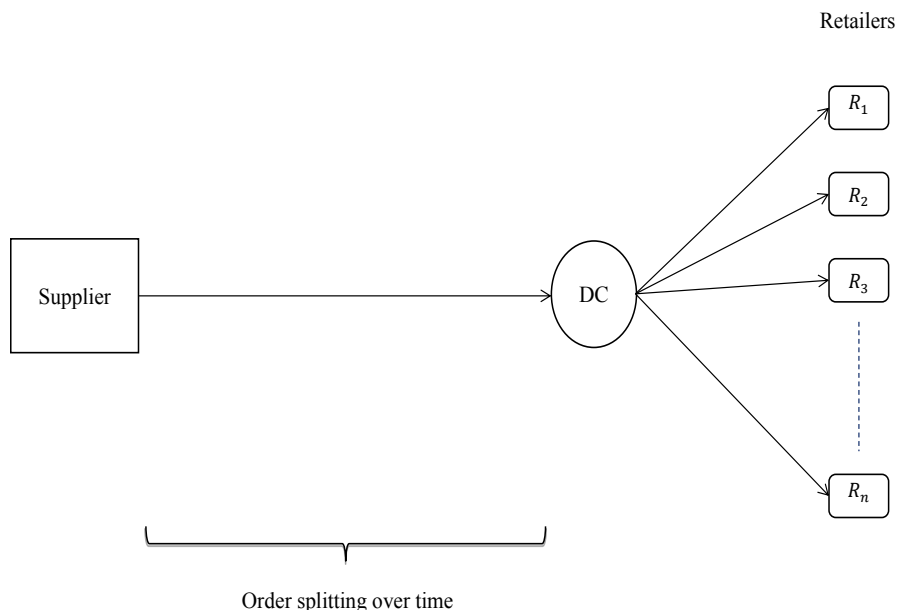

Figure 2.2: Integration of consolidated distribution and order splitting

The only research work similar to ours is done by Ganeshan (1999). In this paper, he introduces a supply chain consisting of a central warehouse feeding a set of retailers which is replenished by several suppliers. He analyzes the inventory at the retailers and warehouse as well as the demand process at the warehouse. Both demand and lead time are stochastic. The total logistics cost includes ordering, inventory, and transportation costs. However, he does not consider the purchasing cost and the impact of the retailers' demand aggregation on it. Using simulation, he concludes that the analytical model is reasonably accurate in obtaining service levels within 3.59% at the retailer level, and within 1.12% at the warehouse.

In our research work, we consider another important logistic cost element, purchasing cost, in the model. There are other order splitting works that have included this cost (Ganeshan et al. 1999; Tyworth and Ruiz-Torres 2000; Mishra and Tadikamalla 2006). However, in our work, the purchasing price follows a stepwise function, meaning that the increase in order quantity results in lower purchasing cost for the buyer. We believe that quantity discount is an important element in order splitting models, especially when the demand is aggregated via a DC.

2.4 Interaction of Consolidated Distribution and Order Splitting

Another potentially important influence of the development of an optimal quantity discount schedule is on shipping cost. By ordering larger quantities, the vendor can capture transportation discounts currently unavailable to him. Finally, larger individual orders changes the current pattern of orders placed throughout the year. This causes a shift in both the magnitude and timing of order payments from the buyer. Consequently, the vendor then finds he gets the use of more the buyer's money, earlier in the year. Depending upon the size of the particular opportunity cost of capital, this can be very important to the vendor (Monahan, 1984).

In this research, we consider the impact of order splitting at a multi-echelon level, where there are retailers who place their orders on a single supplier through a DC. Under such an assumption, the DC in the system receives replenishment quantities from only one higher level site, but can distribute to several lower levels. This single sourcing scenario seems plausible especially in the last decade, which has seen a significant shift in the sourcing strategy of many firms, moving from the traditional concept of having many suppliers to rely largely on one source (Ganeshan, 1999).

Although splitting the order of a single buyer may result in extra costs, splitting the aggregated order of multiple buyers may bring benefits to the system other than those discussed above. Order splitting can have the same impact as other risk pooling strategies, such as consolidated distribution or postponement, from the point of view that delaying the delivery of second or next shipments can result in obtaining actual information about postponed shipments. This could be discussed, for example, under the title "partial postponement", which has been argued by Graman (1999; 2010), but from another angle.

We also assume that a business is implementing order splitting over time, and not over suppliers. That means, there is only one supplier and the order is split and delivered at different points of time. The case of splitting a single supplier order has been studied by Mishra and Tadikamalla (2006), Hill (1996), and Chiang and Chiang (1996). Based on the work of Mishra and Tadikamalla (2006), we assume that many advantages of dual sourcing arise from order splitting rather than actually using two suppliers. This assumption supports our approach in using order-splitting between supplier and DC, i.e. downstream part of our supply chain where we want to take advantage of quantity discounts.

2 Review of the Related Research

We believe that our research model is practical and mathematically simple. We take into consideration almost all advantages and disadvantages of consolidated distribution and order splitting. We moderate the disadvantage of one strategy with its integration in the other one.

Figure 2.2 presents a general overview of this research framework. As it is shown, the application of order splitting, before the decoupling point, in a multi-echelon supply chain (supplier, distribution center (DC), and warehouses) will be investigated. We do not consider order splitting between DC and retailers. We assume that the demand of the retailers is pooled through the DC, and a single supplier/manufacturer feeds the DC.

3 Mathematical Modeling of the Four Strategies

In this chapter, the mathematical models of this research are presented. The objective is to compare the total logistics cost of Direct Shipping (DS), Direct Shipping with Order Splitting (DSOS), Consolidated Distribution (CD), and Consolidated Distribution with Order Splitting (CDOS). We discuss these four mathematical models in section 3.2.

3.1 Notational Terms

In order to better understand the mathematical models, the objective functions, decision variables, and parameters are explained here.

Objective Functions:

TAC_{noOS}^{noCD} : total annual system cost in the case of Direct Shipping to retailers without order splitting (DS model);

TAC_{OS}^{noCD} : total annual system cost in the case of Direct Shipping to retailers with order splitting (DSOS model);

TAC_{noOS}^{CD} : total annual system cost in the case of Consolidated Distribution without order splitting (CD model);

TAC_{OS}^{CD} : total annual system cost when both Consolidated Distribution and Order Splitting are implemented (CDOS model);

Decision Variables:

Q_n : order quantity at retailer n ;

Q_0 : order quantity at DC, $Q_0=Q_nN$, which is the multiplication of order quantity at a single retailer by the total number of retailers N . All retailers are identical;

3 Mathematical Modeling of the Four Strategies

R_n : reorder point at retailer n ;

R_0 : reorder point at DC;

Parameters:

N : total number of retailers, where $n = 1, 2, \dots, N$;

D_n : total annual demand at retailer n ;

D_0 : total annual demand at DC, $D_0 = D_n N$, which is the multiplication of total annual demand at a single retailer by the total number of retailers N ;

c : unit purchasing price from the supplier which is a function of order quantity, where $q^k < Q_n \leq q^{k+1}$ and $q^k < Q_0 \leq q^{k+1}$, and q^k is the k^{th} price breakpoint in the price table;

r_i : i^{th} proportion of order quantity which is transported by the supplier to DC or retailer n , where $i = 1, 2$ and $\sum_{i=1}^I r_i = 1$;

w : item weight;

T : shipment weight, where $T = Q_n w$ or $T = Q_0 w$;

Z : distance between two facilities;

TC : total transportation cost which is a function of shipment weight T and distance Z ;

O : cost of placing an order at DC or retailers;

B : cost of receiving an order at DC or retailers;

A : a multiple for receiving cost of a split order ($A > 1$) representing the incremental cost of splitting orders which is the same at DC and retailers;

H_n : annual inventory holding cost of an item at retailer n expressed as a percentage of value of an item;

H_0 : annual inventory holding cost of an item at DC expressed as a percentage of value of an item;

H_0^{it} : annual inventory in-transit cost of an item from supplier to DC expressed as a percentage of value of an item;

H_n^{it} : annual inventory in-transit cost of an item from supplier or DC to retailer n expressed as a percentage of value of an item;

t : a variable representing transit time;

η : a fixed order-to-ship time component of lead time;

l : a variable representing lead time;

d : a variable representing daily demand;

3.1 Notational Terms

$\mu(l_{s0i})$: mean of the lead time from supplier to DC for the i^{th} proportion of Q_0 (in case of order splitting), where $i = 1, 2$;

$\mu(l_{sni})$: mean of the lead time from supplier to retailer n for the i^{th} proportion of Q_n (in case of order splitting), where $i = 1, 2$;

$\mu(l_{sn})$: mean of the lead time from supplier to retailer n (in case of no order splitting);

$\mu(l_{s0})$: mean of the lead time from supplier to DC (in case of no order splitting);

$\mu(l_{0n})$: mean of the lead time from DC to retailer n (in case of no order splitting);

$\mu(t_{sn})$: mean of the transit time from supplier to retailer n ;

$\mu(t_{s0})$: mean of the transit time from supplier to DC;

$\mu(t_{0n})$: mean of the transit time from DC to retailer n ;

$\mu(d_n)$: mean of the daily demand at retailer n ;

$\mu(d_0)$: mean of the daily demand at DC;

$\mu(LTD_{s0i})$: mean of the lead time demand from supplier to DC for the i^{th} proportion of Q_0 (in case of order splitting);

$\mu(LTD_{sni})$: mean of the lead time demand from supplier to retailer n for the i^{th} proportion of Q_n (in case of order splitting);

$\mu(LTD_{sn})$: mean of the lead time demand from supplier to retailer n (in case of no order splitting);

$\mu(LTD_{s0})$: mean of the lead time from supplier to DC (in case of no order splitting);

$\mu(LTD_{0n})$: mean of the lead time from DC to retailer n (in case of no order splitting);

$\sigma(l_{s0i})$: standard deviation of the lead time from supplier to DC for the i^{th} proportion of Q_0 (in case of order splitting);

$\sigma(l_{sni})$: standard deviation of the lead time from supplier to retailer n for the i^{th} proportion of Q_n (in case of order splitting);

$\sigma(l_{sn})$: standard deviation of the lead time from supplier to retailer n (in case of no order splitting);

$\sigma(l_{s0})$: standard deviation of the lead time from supplier to DC (in case of no order splitting);

$\sigma(l_{0n})$: standard deviation of the lead time from DC to retailer n (in case of no order splitting);

$\sigma(t_{sn})$: standard deviation of the in transit time from supplier to retailer n ;

$\sigma(t_{s0})$: standard deviation of the in transit time from supplier to DC;

3 Mathematical Modeling of the Four Strategies

- $\sigma(t_{0n})$: standard deviation of the in transit time from DC to retailer n ;
- $\sigma(d_n)$: standard deviation of the daily demand at retailer n ;
- $\sigma(d_0)$: standard deviation of the daily demand at DC;
- $\sigma(LTD_{s0i})$: standard deviation of the lead time demand from supplier to DC for the i^{th} proportion of Q_n (in case of order splitting);
- $\sigma(LTD_{sni})$: standard deviation of the lead time demand from supplier to retailer n for the i^{th} proportion of Q_n (in case of order splitting);
- $\sigma(LTD_{sn})$: standard deviation of the lead time demand from supplier to retailer n (in case of no order splitting);
- $\sigma(LTD_{s0})$: standard deviation of the lead time from supplier to DC (in case of no order splitting);
- $\sigma(LTD_{0n})$: standard deviation of the lead time from DC to retailer n (in case of no order splitting);
- CS : cycle stock;
- IT : in-transit stock;
- SS : safety stock;
- β : service level;
- ES_n : expected number of shortages per cycle at retailer n in case of no order splitting;
- ES_0 : expected number of shortages per cycle at DC in case of no order splitting;
- ES_n^{OS} : expected number of shortages per cycle at retailer n in case of order splitting;
- ES_0^{OS} : expected number of shortages per cycle at DC in case of order splitting.

Note that anywhere in this manuscript when a variable has a subscript s , 0 , n , and i , it refers to supplier, DC, retailer n and i^{th} proportion of lot size, respectively; For example, $\mu(l_{s02})$ means the average lead time from supplier to DC for the second portion of Q_0 (in case of order splitting).

3.2 Optimization Models

The aim of this research is to investigate the impact of simultaneous application of consolidated distribution and order splitting on a supply chain consisting of one supplier, one DC and N retailers. To do so, we first model the total cost of Direct Shipping system (DS model). Then, we consider the total cost

of Direct Shipping with Order Splitting system (DSOS model) and, a Consolidated Distribution system (CD model), separately. We then integrate these two strategies to consider the impact of their integration on a supply chain (CDOS model). The inventory policy is continuous review (Q, R) throughout this research work. The total annual cost is the sum of Purchasing Cost (PC), Transportation Cost (TC), Ordering Cost (OC), Cycle Stock holding Cost (CSC), Safety Stock holding Cost (SSC), and In-Transit stock Cost (ITC).

$$TAC = PC + TC + OC + CSC + SSC + ITC \tag{3.1}$$

Figure 3.1 presents the cost structure of the models. The cost elements are later in this section described in detail.

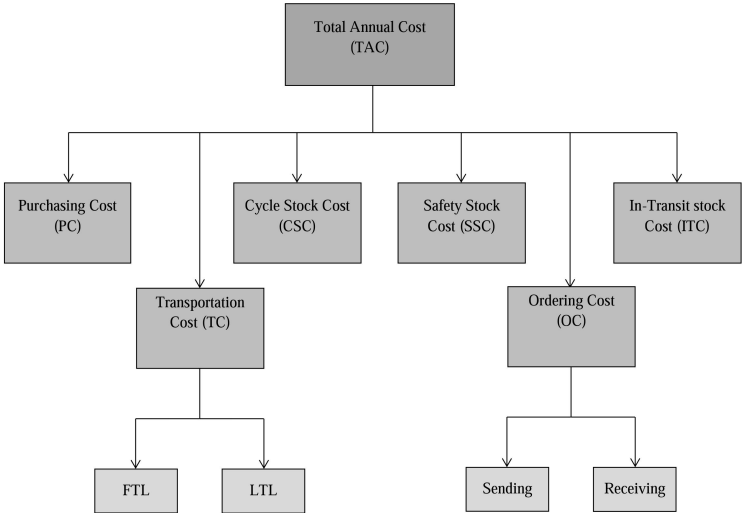

Figure 3.1: The cost structure

For all models, assume that $f(\cdot)$ and $F(\cdot)$ be, respectively, the probability distribution function (pdf) and cumulative distribution function (cdf) of lead-time l , and $g(\cdot)$ and $G(\cdot)$ be, respectively, the pdf and cdf of daily demand d . Similarly, assume that $w(\cdot)$ and $W(\cdot)$ be, respectively, the pdf and cdf of lead time demand LTD.

3.2.1 Direct Shipping without Order Splitting (DS Model)

In the DS model, the order quantity is directly shipped from a single supplier to each retailer (no order-splitting and no consolidated distribution).

$$\begin{aligned} \text{Min} \quad TAC_{noOS}^{noCD} = & \{D_n c + \frac{D_n}{Q_n} TC(Q_n) + \frac{D_n}{Q_n} (O + B) + H_n (\frac{Q_n}{2}) + \\ & + H_n (R_n - \mu(LTD_{sn})) + H_n^{it} \mu(LTD_{sn})\} N \end{aligned} \quad (3.2)$$

S.t. :

$$\begin{aligned} ES_n &\leq \alpha Q_n \quad \text{where } \alpha = 1 - \beta, \quad n = 1, 2, \dots, N \\ Q_n &\geq 1 \\ R_n &\geq 1 \end{aligned}$$

In equation 3.2, the first and second terms represent purchasing and transportation costs. Purchasing price c is a function of order quantity Q_n , where $q^k < Q_n \leq q^{k+1}$. To determine the purchasing price, different ranges of rates for a purchasing quantity are generated. This approach is used when the suppliers offer volume discounts to stimulate the buyers for purchase of larger quantities.

Transportation cost per cycle TC, which is a function of order quantity Q_n , consists of two components. The full truck load (FTL) and less than truck load (LTL) components. If the shipment weight is equal to the capacity of x FTLs, the transportation cost is then calculated through the following formula:

$$Z \times FTL \text{ rate per mile} \times x \quad (3.3)$$

where x is the number of FTL shipments.

For that part of the shipment which is less than a FTL capacity, the following formula is used:

$$Z \times LTL \text{ rate per mile} \times 0.7^{\log_2(\frac{\text{capacity of a FTL}}{T})} \quad (3.4)$$

where T is the shipment weight for LTL shipments. This is a realistic

formula which was provided by a former manager at Bosch Corporation and, according to him, can be used in any country and for a variety of products.

The third term is the ordering cost, OC. The ordering cost is divided into two types of costs. One is the cost of sending out an order (O) which includes costs of preparing specifications, obtaining letters of credit, etc. and the other is the cost of receiving an incoming procurement (B) such as cost of monitoring the shipment, handling and inspection of the procurement when it arrives, etc.

The fourth, fifth and sixth terms indicate the CS, SS and IT costs where SS can be calculated as

$$SS = R_n - \mu(LTD_{sn}) \quad (3.5)$$

Note that $\mu(LTD_{sn}) = \mu(d_n)\mu(l_{sn})$. In order to calculate R_n , we first need to mention that the service level β can be calculated through the following formula (Tadikamalla, 1978):

$$\beta = \int_0^{R_n} w(x)d(x) \quad (3.6)$$

Therefore, in equation 3.2, R_n can be computed through numerical calculations or (given a specific service level) the following equation (Tadikamalla, 1978):

$$R_n = W^{-1}(\beta) \quad (3.7)$$

In this work, we consider the system inventory cost that also includes the in transit inventory. IT is the average demand during the transit time t and appears η periods after the order is placed, i.e. $t = l - \eta$. Hence, IT can be calculated as:

$$ITC = \mu(LTD_{sn}) = \mu(d_n) \mu(t_{sn}) \quad (3.8)$$

3 Mathematical Modeling of the Four Strategies

Thus, the problem in equation 3.2 is to find the optimal order quantity Q_n^* and reorder point R_n^* such that TAC_{noOS}^{noCD} is minimized subject to a maximum allowable stock-out risk, so that $ES_n \leq \alpha Q_n$, where $\alpha = 1 - \beta$.

Where ES_n can be calculated through the following formula (First order loss function- see Tempelmeier, 2015):

$$ES_n = \int_{R_n}^{\infty} (x - R_n) w(x) d(x) \quad (3.9)$$

3.2.2 Direct Shipping with Order Splitting (DSOS Model)

In the DSOS model, the demand is directly shipped from one single supplier to each retailer n , but it is split. That means the first shipment is sent at time 0 and the second shipment is delivered after a fixed time θ .

$$\begin{aligned} \text{Min} \quad TAC_{OS}^{noCD} = & \{D_n c + \frac{D_n}{Q_n} \sum_{i=1}^I TC(r_i Q_n) + \frac{D_n}{Q_n} (O + AB) + \\ & H_n \left(\frac{Q_n}{2} - r_2 \mu(d_n) [\mu(l_{sn2}) - \mu(l_{sn1})] \right) + H_n (R_n - \\ & \mu(LTD_{sn1})) + H_n^{it} \mu(LTD_{sn1}) \} N \end{aligned} \quad (3.10)$$

S.t. :

$$\begin{aligned} ES_n^{OS} & \leq \alpha Q_n \quad \text{where } \alpha = 1 - \beta, n = 1, 2, \dots, N \\ Q_n & \geq 1 \\ R_n & \geq 1 \end{aligned}$$

Here, because all portions of the order of each retailer are supplied by a single supplier, the purchasing price for all units and all portions of Q_n is the same. However, the retailer may pay more transportation cost per unit as its order is split into smaller quantities.

For the ordering cost, the difference between the DS and DSOS models lies in the multiplier A which indicates the increase in the cost of receiving two shipment quantities. We use the following formulas to calculate CS and SS costs for order splitting with stochastic lead time and demand in the fourth

and fifth terms, respectively. Hence, CS and SS, respectively, are calculated as (Lau and Zhao, 1993):

$$CS = \frac{Q_n}{2} - r_2 \mu(d_n) [\mu(l_{sn2}) - \mu(l_{sn1})] \quad (3.11)$$

$$SS = R_n - \mu(LTD_{sn1}) \quad (3.12)$$

The last term, IT inventory cost does not depend on the number of suppliers and its calculation is the same as in the DS model.

Thus, the problem in equation 3.10 is to find the optimal order quantity Q_n^* and reorder point R_n^* such that TAC_{OS}^{noCD} is minimized subject to a maximum allowable stock-out risk, so that $ES_n^{OS} \leq \alpha Q_n$, where $\alpha = 1 - \beta$.

ES_n^{OS} is calculated according to equation 3.13 (Lau and Zhao, 1993). In this equation, V_{ij} is the probability of occurrence of situation i . “Situation 1” and “Situation 2” refer to the situation where the first arriving order is the first and second shipment, respectively. Correspondingly, V_{11} refers to the probability of stock-out in situation 1 before the arrival of the first shipment and V_{12} is the probability of stock-out in situation 1 before the arrival of the second shipment but after the arrival of the first shipment. As the lead time is stochastic, it may happen that the second shipment arrives before the first shipment.

$$ES_n^{OS} = (V_{11} + V_{12} + V_{21} + V_{22}) Q_n \quad (3.13)$$

The procedure for calculating V_{ij} is explained in section 3.4.

3.2.3 Consolidated Distribution without Order Splitting (CD Model)

In the CD model, units are first delivered to the distribution center where after possibly remaining as inventory for some time, they are subsequently delivered to the retailers. Here, consolidated distribution (CD) is considered

3 Mathematical Modeling of the Four Strategies

without order splitting. The total cost here is the total cost at the DC plus the cost at retailers' facility. The total cost of the retailers is highlighted by an underline.

$$\begin{aligned}
 \text{Min} \quad TAC_{noOS}^{CD} = & D_0c + \frac{D_0}{Q_0}TC(Q_0) + \frac{D_0}{Q_0}(O + B) + H_0\left(\frac{Q_0}{2}\right) + \\
 & H_0(R_0 - \mu(LTD_{s0})) + H_0^{it}\mu(LTD_{s0}) + \underbrace{\left\{\frac{D_n}{Q_n}TC(Q_n) + \right.}_{(3.14)} \\
 & \left. + \frac{D_n}{Q_n}(B) + H_n\left(\frac{Q_n}{2}\right) + H_n(R_n - \mu(LTD_{0n})) + \right. \\
 & \left. \underbrace{H_n^{it}\mu(LTD_{0n})\}_{N}}
 \end{aligned}$$

S.t. :

$$ES_0 \leq \alpha Q_n \quad \text{where } \alpha = 1 - \beta, \quad n = 1, 2, \dots, N$$

$$ES_0 \leq \alpha Q_0 \quad \text{where } \alpha = 1 - \beta$$

$$Q_n \geq 1$$

$$Q_0 \geq 1$$

$$R_n \geq 1$$

$$R_0 \geq 1$$

In this model, the DC aggregates the order of retailers and places the aggregated order on the supplier. Therefore, DC bears a cost of placing the order (O) and receiving the order (B). However, since the DC, and not the retailers, places the order, the only ordering cost that the retailers bear is the cost of receiving the shipment (B).

Compared to the DS and DSOS models, the purchasing cost may decrease since the aggregated purchase of retailers' order can result in taking advantage of quantity discounts. It is also assumed that DC and retailers are all one entity/company. Therefore, the purchasing cost is calculated just one time for the entire system.

From the transportation cost point of view, establishment of DC reduces shipment cost from supplier to DC by aggregating the order quantities of retailers which results in larger shipment quantities. However, the total distance (or to say "lead time") from supplier to DC and from DC to retailers is longer. Therefore, increase or decrease in transportation cost depends on the trade-off

between this extra distance, or lead time, and the amount of savings due to aggregation. Obviously, it would be more beneficial if the distance between supplier and DC is longer compared to the distance between DC and retailers.

Generally, a DC may or may not hold inventory. In case it holds inventory (Schwarz, 1989), a system order is placed by and shipped to the DC, arriving after a lead time l . Then, it is kept in DC for a while and is then reallocated to the retailers. In this work, we consider the case where the DC keeps inventory.

Since both DC and retailers keep inventory, the cycle and safety inventory costs in the CD model are higher compared to the DS or DSOS models. However, the unit inventory holding cost at DC is lower at the DC because of more expensive retailer shelf space. The in-transit stock cost of the CD model is the sum of in-transit cost from supplier to DC and from DC to retailers. Again, because of longer total distance or lead time, it is higher compared to the DS and DSOS models.

Thus, the problem in equation 3.14 is to find the optimal order quantity Q^* and reorder point R^* at DC and retailers such that TAC_{noOS}^{CD} is minimized subject to a maximum allowable stock-out risk, so that $ES_n \leq \alpha Q_n$, and $ES_0 \leq \alpha Q_0$ where $\alpha = 1 - \beta$.

ES_n can be calculated through the following formula:

$$ES_n = \int_{R_n}^{\infty} (x - R_n) w(x) d(x) \quad (3.15)$$

For the expected number of shortages at DC, assume that x_0 is the demand during lead time. If inventory reaches the reorder level R_0 , the DC places an order of Q_0 units on the supplier. Therefore, the probability of stock-out at DC is:

$$Pr(ES_0) = Pr(x_0 > R_0) \quad (3.16)$$

and, ES_0 equals to:

$$ES_0 = \int_{R_0}^{\infty} (x - R_0) w(x) d(x) \quad (3.17)$$

3.2.4 Integration of the OS and CD Systems (CDOS Model)

In the CDOS model, we integrate consolidated distribution and order splitting. We believe that through this integration, the disadvantages of one strategy can be compensated by the advantages of the other. We presume that the disadvantages of order splitting (increases in transportation and ordering costs) will be somehow or completely compensated by its integration with consolidated distribution and the disadvantages of consolidated distribution (increases in cycle and safety stock holding costs) can be compensated by order splitting.

$$\begin{aligned}
 \text{Min} \quad TAC_{OS}^{CD} = & D_0c + \frac{D_0}{Q_0} \sum_{i=1}^I TC(r_i Q_0) + \frac{D_0}{Q_0} (O + AB) + \\
 & H_0 \left(\frac{Q_0}{2} - r_2 \mu(d_0) [\mu(l_{s02}) - \mu(l_{s01})] \right) + H_0(R_0 - \mu(LTD_{s01})) + \\
 & H_0^{it} \mu(LTD_{s01}) + \underbrace{\left\{ \frac{D_n}{Q_n} TC(Q_n) + \frac{D_n}{Q_n} (B) + \right.}_{N} \\
 & \left. H_n \left(\frac{Q_n}{2} \right) + H_n(R_n - \mu(LTD_{0n})) + H_n^{it} \mu(LTD_{0n}) \right\} N
 \end{aligned} \tag{3.18}$$

S.t. :

$$ES_0^{OS} \leq \alpha Q_n \quad \text{where } \alpha = 1 - \beta, \quad n = 1, 2, \dots, N$$

$$ES_0^{OS} \leq \alpha Q_0 \quad \text{where } \alpha = 1 - \beta$$

$$Q_n \geq 1$$

$$Q_0 \geq 1$$

$$R_n \geq 1$$

$$R_0 \geq 1$$

The fourth model is the modification of the CD model but the order quantity of the DC is split. The only difference of the CDOS model with the CD model is that in the CDOS model, the transportation, ordering, cycle and safety stock costs at the DC are calculated similar to the DSOS model. Other cost elements are, however, calculated the same as in the CD model. Again, the

3.3 Computation of Cycle and Safety Stock in Order Splitting Model

total cost at the retailers' facility is highlighted by an underline.

Thus, the problem in equation 3.18 is to find the optimal order quantity Q^* and reorder point R^* at DC and retailers such that TAC_{OS}^{CD} is minimized subject to a maximum allowable stock-out risk, so that $ES_n \leq \alpha Q_n$, and $ES_0^{OS} \leq \alpha Q_0$ where $\alpha = 1 - \beta$.

The derivation of ES_n in the CDOS model is similar to the CD model. Therefore, it is calculated as:

$$ES_n = \int_{R_n}^{\infty} (x - R_n) w(x) d(x) \quad (3.19)$$

and, as in the DSOS model, ES at DC equals to:

$$ES_0^{OS} = (V_{11} + V_{12} + V_{21} + V_{22}) \cdot Q_0 \quad (3.20)$$

3.3 Computation of Cycle and Safety Stock in Order Splitting Model

In this section, the procedure for computing CS and SS in the DSOS model is explained. Similar procedure can be applied for the CDOS model.

Figure 3.2 shows the traditional continuous review (Q, R) inventory policy. According to this figure, an order quantity of Q_n is placed on the supplier whenever the inventory level reaches the reorder point R_n . This order quantity, then, arrives after l_{sn} periods where this lead time can be deterministic or stochastic.

3 Mathematical Modeling of the Four Strategies

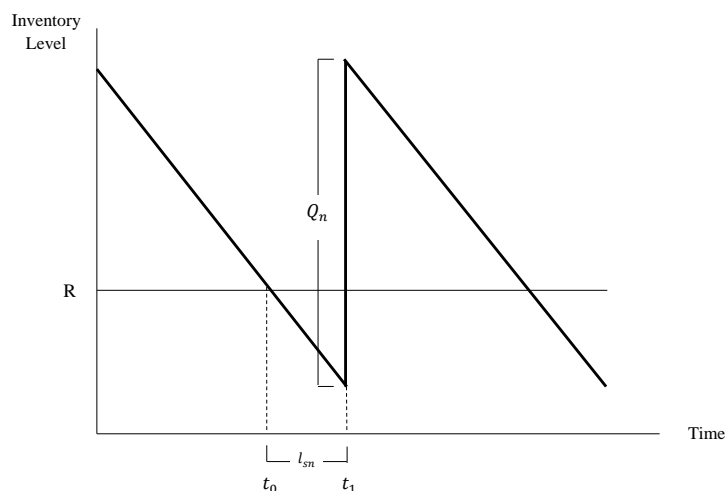

Figure 3.2: Traditional (Q, R) inventory policy

In Figure 3.3, the order quantity Q_n is split and the i^{th} proportion of Q_n is placed on supplier j , S_j ($j = 1, 2, \dots, J$), who have different lead times. We call order splitting via more than one supplier as “order splitting over suppliers”. Lau and Zhao (1993) derive expressions for safety and cycle stock for this case.

$$SS = R_n - \mu(LTD_{sn1}) \quad (3.21)$$

$$CS = \frac{Q}{2} - r_2 \mu(d_n) [\mu(l_{sn2}) - \mu(l_{sn1})] \quad (3.22)$$

where $\mu(l_{sn1})$ and $\mu(l_{sn2})$ are, respectively, the lead time from supplier to the retailer for the arrival of the first and second portions of the order quantity.

As it shows, the savings in cycle stock depend only on expected lead times, and the standard deviation of lead time plays no role. In addition, two suppliers with the same average lead time make no benefit to order splitting.

3.3 Computation of Cycle and Safety Stock in Order Splitting Model

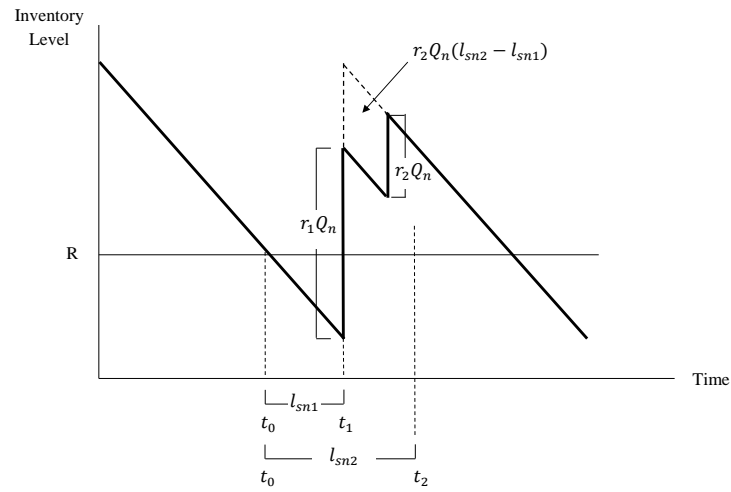

Figure 3.3: Oder splitting over suppliers

Figure 3.4 shows order splitting via a single supplier in which the process is similar to Figure 3.3. We call it “order splitting over time”. The difference with order splitting over suppliers is that when the inventory level reaches R_n , the DC or retailer places the order and a single supplier ships the first portion of order quantity, $r_1 Q_n$, at time zero and the second portion, $r_2 Q_n$, after θ periods.

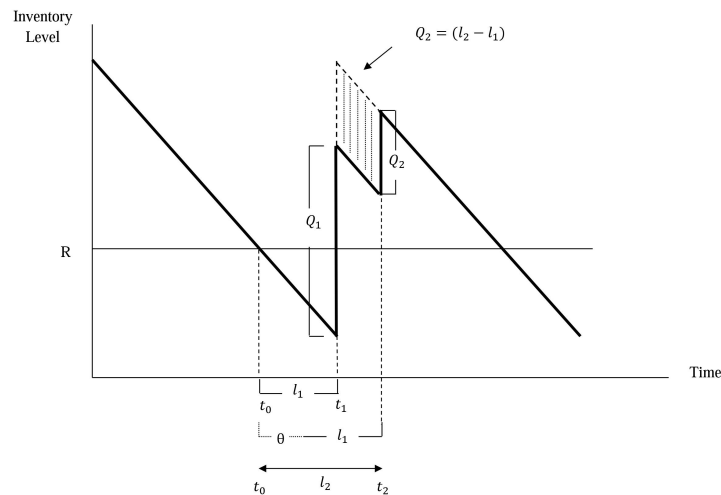

Figure 3.4: Order splitting over time (a single supplier)

The formulas for the calculation of safety and cycle safety stock are the same as in equations 3.21 and 3.22. However, l_{sn2} is equal to $l_{sn1} + \theta$.

3.4 Probability of Stock-out in Order Splitting Model

In this section (section 3.4), the procedure developed by Lau and Zhao (1993) for calculating the probability of stock-out in the order splitting model for the case of stochastic demand and lead time is explained. Therefore, the formulas are adopted from their work. We use the same procedure for calculating the probability of stock-out for the split orders in the DSOS and CDOS models. The reason is that many of order splitting models in the literature have assumed that either lead time or demand is stochastic. There are not many models with stochastic lead time and stochastic demand. Moreover, the proposed procedure is simple to understand and apply.

In an order splitting model, the probability of stock-out is the summation of probability of stock-out in two situations. Assume that x is the stochastic quantity of demand between the time of replenishment (t_0) and the arrival time of the first supplier shipment (t_1). When lead times are stochastic, it may happen that the order of the second supplier arrives before or after the first supplier's order. In case supplier 1 arrives earlier than supplier 2, it is called "Situation 1", S_1 . Otherwise, it is called "Situation 2", S_2 .

In situation 1, the probability of stock-out before the arrival of supplier 1's order is called V_{11} . Define the first and second subscript in V_{11} as "situation" and "supplier". V_{11} equals to:

$$V_{11} = W'_{11}(R_n).S_1 \quad (3.23)$$

where,

$$W'_{11}(\cdot) = 1 - W_{11}(\cdot) \quad (3.24)$$

and, W_{11} is the cumulative distribution function (cdf) of lead time demand, and S_1 is the probability that the first arriving order comes from supplier 1. The demanded quantity within this period of time is x_{11} . Similarly, V_{12} is defined as the probability of stock-out before the arrival of supplier 2's order but after the arrival of supplier 1's order and equals to:

$$V_{12} = W'_{12}(R_n + r_1 Q_n).S_1 \quad (3.25)$$

3.4 Probability of Stock-out in Order Splitting Model

Based on the abovementioned discussion, the probability of stock-out in situation 2 can be defined as:

$$V_{21} = W'_{21}(R_n + r_2 Q_n) \cdot S_2 \quad (3.26)$$

$$V_{22} = W'_{22}(R_n) \cdot S_2 \quad (3.27)$$

Therefore, the probability of stock-out in the order splitting model is:

$$V_{11} + V_{12} + V_{21} + V_{22} \leq \alpha \quad (3.28)$$

3.4.1 Computing the Probability of Situation i

Assume that $l_1 = x$ is the lead time of supplier 1's shipment and it precedes the second supplier's lead time. Then, situation 1 occurs whose probability is

$$Pr(l_1 = x \text{ and } l_2 > x) = f_1(x) dx \cdot F'_2(x) \quad (3.29)$$

It can be shown as:

$$S_1 = \int_{-\infty}^{\infty} f_1(x) \cdot F'_2(x) dx \quad (3.30)$$

Equal to this probability is the probability of the event when the shipment of the second supplier arrives with $l_2 = y$ and after the arrival of the first supplier's shipment and is defined as

$$Pr(l_2 = y \text{ and } l_2 > x) = f_2(y) dy \cdot F_1(y) \quad (3.31)$$

Again, it can be shown as:

$$S_1 = \int_{-\infty}^{\infty} f_2(y) \cdot F_1(y) dy \quad (3.32)$$

Similarly, the probability of situation 2 can be calculated as

$$S_2 = \int_{-\infty}^{\infty} f_1(y) \cdot F_2(y) dy \quad (3.33)$$

or,

$$S_2 = \int_{-\infty}^{\infty} f_2(x) \cdot F_1'(x) dx \quad (3.34)$$

3.4.2 Defining Lead Time Distributions

In order to calculate the central moments of the lead time distribution, we have to first define its probability distribution function (pdf). Given situation 1, assume that l_{11} is the stochastic duration between the time of replenishment t_0 and the arrival time of the first shipment t_1 . Based on equation 3.30, the probability distribution of lead time l_{11} , i.e. f_{11} , equals to:

$$f_{11}(x) = f_1(x) \cdot F_2'(x) / \int_{-\infty}^{\infty} f_1(x) \cdot F_2'(x) dx \quad (3.35)$$

The lead time distribution f_{12} for the stochastic duration l_{12} between t_0 and t_2 in situation 1 is also,

$$f_{12}(x) = f_2(x) \cdot F_1(x) / \int_{-\infty}^{\infty} f_2(x) \cdot F_1(x) dx \quad (3.36)$$

Similarly, f_{21} and f_{22} are defined via the following equations:

$$f_{21}(x) = f_1(x) \cdot F_2(x) / \int_{-\infty}^{\infty} f_1(x) \cdot F_2(x) dx \quad (3.37)$$

$$f_{22}(x) = f_2(x) \cdot F_1'(x) / \int_{-\infty}^{\infty} f_2(x) \cdot F_1'(x) dx \quad (3.38)$$

3.4.3 Computing the Cumulative Distribution Functions for Order Splitting Model

In this sub-section, the procedure proposed by Lau and Zhao (1993) for computing the parameters of lead time demand (LTD), $W_{ij}(\cdot)$, and consequently, $W'_{ij}(\cdot)$ of lead time demand is illustrated. This procedure uses the method of moments. In this work, LTD is assumed to have a Weibull distribution, but demand and lead time distributions can be of any form. Assume that x_{11} is the stochastic quantity of inventory demanded between the time the order is placed, t_0 , and the time the first shipment is arrived, t_1 , if situation 1 occurs. The cumulative distribution function is $W_{11}(\cdot)$ and is formed by the stochastic demand pdf $g(\cdot)$ and the stochastic lead time pdf $f_{11}(\cdot)$.

3.4 Probability of Stock-out in Order Splitting Model

Step 1: Calculate the first three raw moments of lead time, $\mu'_n(x) = E(x^n)$, for f_{ij} 's using the following formula:

$$\mu'_n(l_{ij}) = \int_{-\infty}^{\infty} x^n f_{ij}(x) dx \quad (3.39)$$

For example, $\mu'_n(l_{11})$ is calculated as:

$$\mu'_n(l_{11}) = \int_{-\infty}^{\infty} x^n f_{11}(x) dx = \left\{ \int_{-\infty}^{\infty} x^n f_1(x) \cdot F'_2(x) dx \right\} / S_1 \quad (3.40)$$

Step 2: Calculate the first three central moments of f_{ij} 's as follows:

$$\mu_1 = \mu'_1 \quad (3.41)$$

$$\mu_2 = \mu'_2 - \mu_1'^2 \quad (3.42)$$

$$\mu_3 = \mu'_3 - 3\mu_1'\mu_2' + 2\mu_1'^3 \quad (3.43)$$

Step 3: Use standard formulas to determine the first three raw moments of a specific distribution for daily demand $g(\cdot)$, and subsequently, its first three central moments from equations 3.41, 3.42, and 3.43. For example, for a normal distribution, these are $\mu_1 = \mu$, $\mu_2 = \sigma^2$, and $\mu_3 = 0$.

Step 4: Compute the first three central moments of lead time demand distribution from the first three central moments of lead time and demand distributions using the formulas illustrated below:

$$\mu_1(x_{ij}) = \mu_1(l_{ij}) \cdot \mu_1(d) \quad (3.44)$$

$$\mu_2(x_{ij}) = \mu_1(l_{ij}) \cdot \mu_2(d) + \mu_2(l_{ij}) \cdot \mu_1^2(d) \quad (3.45)$$

$$\mu_3(x_{ij}) = \mu_1(l_{ij}) \cdot \mu_3(d) + 3\mu_2(l_{ij}) \cdot \mu_2(d) \cdot \mu_1(d) + \mu_3(l_{ij}) \cdot \mu_1^3(d) \quad (3.46)$$

Step 5: Fit these first three central moments to the cdf of a 3-parameter Weibull distribution:

$$W_{ij}(x) = 1 - \exp \left\{ - \left[\frac{x - a}{b} \right]^c \right\} \quad (3.47)$$

a , b and c are the location, scale, and shape parameters of a Weibull distribution, respectively. Next, we have

$$W'_{ij}(x) = \exp \left\{ - \left[\frac{x - a}{b} \right]^c \right\} \quad (3.48)$$

Using the above-mentioned procedures for the calculation of S_i and W'_{ij} , equations 3.23-3.27 can be solved with numerical search.

It is argued by many researchers (e.g. Burgin, 1972; Murphy, 1975; Tadikamalla, 1978, Lau and Zhao, 1993) that a 2-parameter Weibull distribution is suitable for modeling a *LTD* distribution and Lau and Zhao (1993) discuss that it is more versatile to model the *LTD* distribution by a 3-parameter Weibull rather than a 2-parameter Weibull distribution.

In this section, the procedure developed by Lau and Zhao (1993) for calculating the probability of stock-out in the order splitting model for the case of stochastic demand and lead time was explained. Following this procedure, one can calculate the expected number of shortages in the order splitting model.

3.5 Computing Cumulative Distribution Functions in Case of Non-Order Splitting

Computing the parameters of the *LTD* distribution $w(\cdot)$ for a non-order splitting model follows the same procedure as presented in section 3.4.3. However, in step 1, instead of using equation 3.39, one can use the following general formula to compute the first three raw moments of lead time distribution:

$$\mu'_n(l) = \int_{-\infty}^{\infty} x^n f(x) dx \quad (3.49)$$

This formula is the same as in equation 3.39. However, instead of $f_{ij}(\cdot)$, which is the pdf of lead time in situation i and for supplier j in order splitting model, $f(x)$ is used as the pdf of lead time from supplier to DC or retailer as there is only one situation. Therefore, in steps 2 and 4, one calculates $\mu_1(l)$ and $\mu_1(x)$ instead of $\mu_1(l_{ij})$ and $\mu_1(x_{ij})$, respectively. In chapter 4, these steps will be applied using the inputs.

4 Evaluation and Results of the Four Strategies

4.1 Computing the Inputs of the Models

In chapter 3, we presented the general computation procedures of the models. In this chapter, we investigate whether the application of the proposed models is beneficial in practice and whether it is tenable to implement either models of the DS, DSOS, CD, or CDOS. In fact, we try to answer the three research questions discussed in chapter 1:

- **RQ1:** *How high is the total cost of a Direct Shipping system where the order quantity is split (DSOS model) compared to a Direct Shipping non-order splitting system (DS model), in case transportation and purchasing cost functions are nonlinear and there is a single supplier?*
- **RQ2:** *How high is the total cost of a system where the retailers' order quantities are consolidated through a DC (CD model) compared to a Direct Shipping non-order splitting system where the retailers' order quantities are directly placed on the supplier (DS model), in case transportation and purchasing cost functions are nonlinear and there is a single supplier?*
- **RQ3:** *How high is the total cost of a system where the retailers' order quantities are consolidated through a DC and the order quantity between supplier and DC is split (CDOS model), compared to a Direct Shipping non-order splitting system where the retailers' order quantities are directly placed on the supplier (DS model), in case transportation and purchasing cost functions are nonlinear and there is a single supplier?*

Table 4.1 represents the parameter values of our basic models. The selected product is a car tire and the average values of the properties of a passenger car

4 Evaluation and Results of the Four Strategies

tire (such as weight and price) have been taken into account when doing the calculations. The value of other parameters of the models are chosen based on discussion with experts, internet websites, or the related research works. For example, the weight of a car tire has been taken from internet websites like Amazon, ebay, etc., the lead time from the supplier to DC or retailers is based on the distances in google maps between the selected geographical points and the average allowed speed of a truck, and the inventory holding factor is selected according to the experts opinions as well as the research papers such as the work of Thomas and Tyworth (2007).

As one may criticize our approach (adopting parameter values from different sources and not a real case), we also try to examine the impact of changes in important parameter values on the TAC of each model by doing a sensitivity analysis. The Key Performance Indicator (KPI) for comparing the models is related to the Total Annual Cost (TAC).

In addition, whenever we talk of the basic models, we mean the four models for which we have used the parameter values from Table 4.1. In our basic models, for example, the demand equals 10 units/day. On the other hand, whenever we talk of the reference model, we mean the DS model, because we compare the other three models with this model.

4.1 Computing the Inputs of the Models

Table 4.1: Value of the parameters

Description	Notation	Metric	Value or calculation formula	Description	Notation	Metric	Value or calculation formula
Average transit time between supplier and DC for 1st shipment	$\mu(t_{s01})$	days	3	Number of retailers	n	retailer	15
Time difference between sending the shipments	θ	days	2	Distance between supplier and DC	Z_{s0}	mile	750
Average transit time between supplier and DC for 2nd shipment	$\mu(t_{s02})$	days	$\mu(t_{s01}) + 2$	Distance between DC and each retailer	Z_{0n}	mile	250
Average transit time between DC and retailers	$\mu(t_{0n})$	days	1	Distance between supplier and each retailer	Z_{sn}	mile	850
Average transit time between supplier and retailers for 1st shipment	$\mu(t_{sn1})$	days	3	Multiplier for increase in ordering cost in order splitting model	A		2
Average transit time between supplier and retailers for 2nd shipment	$\mu(t_{s02})$	days	$\mu(t_{sn1}) + 2$	Cost of sending order	O	\$/order	50
Order processing time at supplier or DC	η	days	1	Cost of receiving order	B	\$/order	50
Average demand at retailer n	$\mu(d)$	units/day	10	Inventory holding cost at retailer n	H_n	\$	$25\%c$
Coefficient of variation of lead time	$CV(l)$		0.25	Inventory holding cost at DC	H_0	\$	$18\%c$
Standard deviation of lead time	$\sigma(l)$		$\mu(l) \times CV(l)$	Inventory IT cost from supplier or DC to retailer n	H_n^{it}	\$	$18\%c$
Annual demand at retailer n	D_n	units/year	3,650	Inventory IT cost from supplier to DC	H_0^{it}	\$	$10\%c$
Item weight	w	pounds/item	22	Split proportion	r_i	percent	50%-50%

4 Evaluation and Results of the Four Strategies

In purchasing, the most common quantity discount form is an “all-units” model (Munson and Hu, 2010). In all-units, the lower price applies to all units purchased, not only to those above the price break. In order to include the all-units form for the purchasing cost, we used the following step-wise function. This is a quantity discount structure for average purchasing price when demand equals 10 units/day.

$$c = f(Q) = \begin{cases} c = 75.00\$/item & 1 \leq Q \leq 1,000 \\ c = 74.00\$/item & 1,000 < Q \leq 3,000 \\ c = 73.00\$/item & 3,000 < Q \leq 7,000 \\ c = 71.50\$/item & 7,000 < Q \leq 15,000 \\ c = 70.50\$/item & 15,000 < Q \leq 26,000 \\ c = 69.00\$/item & 26,000 < Q \end{cases} \quad (4.1)$$

We also use the following realistic freight rate function explained in equations 3.3 and 3.4 in order to calculate the nonlinear transportation cost. This formula is used by department of Logistics at Robert Bosch Corporation.

$$TC(Q) = [Z \times 1.60 \times x] + \left[Z \times 1.60 \times 0.7^{\log_2\left(\frac{45000}{T}\right)} \right] \quad (4.2)$$

The FTL rate per mile (\$1.60) is adopted from the report by American Transportation Research Institute (Torrey and Murray, 2015).

4.1.1 General Procedure for Computing the Moments of Beta and Exponential Distributions

For all models, assume that lead time and demand have beta and exponential distribution, respectively. We chose these distributions to stay in line with the work of Lau and Zhao (1993) whose proposed procedures were explained in section 3.4.3 in chapter 3 and will be applied in this chapter. Similar to their work, we fit the moments of the *LTD* to a 3-parameter Weibull distribution. This is done using “*Excel 2010*” and “*Mathematica 10.0*”.

To achieve this aim, the first step is to calculate the parameters and then, the first three raw and central moments of a beta distribution. The pdf of a beta distribution is (Lau and Zhao (1993)):

4.1 Computing the Inputs of the Models

$$f(x) = \frac{(x-a)^{p-1}(b-x)^{q-1}}{B(p,q)(b-a)^{(p+q-1)}} \quad (4.3)$$

In equation 4.3, a and b are the lower and upper bounds, respectively, p and q are the shape parameters and $B(p,q)$ is the beta function. To get the parameters of the pdf of beta distribution, the following procedure can be used (Elderton and Johnson, 1969; Lau and Zhao, 1993):

$$r = 6 \frac{a_4 - a_3^2 - 1}{6 + 3a_3^2 - 2a_4} \quad (4.4)$$

$$w = [(r+2)a_3]^2 + 16(r+1) \quad (4.5)$$

$$p, q = 0.5r \left[1 + (r+2) \frac{a_3}{\sqrt{w}} \right], \quad (q > p \text{ if } a_3 > 0, p \geq q \text{ otherwise}) \quad (4.6)$$

a and b can also be calculated by:

$$a = \mu - 0.5 \frac{p\sigma\sqrt{w}}{p+q} \quad (4.7)$$

$$b = a + 0.5\sigma\sqrt{w} \quad (4.8)$$

By calculating a , b , p and q , the first three raw moments of the beta distribution can be easily achieved.

Furthermore, if demand is exponentially distributed, its raw moments can be computed by (Lau and Zhao (1993)):

$$\mu'_n = \lambda^{-n} n! \quad (4.9)$$

where λ is the scale parameter.

Now, the first three central moments of beta and exponential distributions can be calculated using equations 3.41, 3.42 and 3.43. Finally, the first three central moments of Weibull distribution can be computed using equations 3.44, 3.45 and 3.46.

4.1.2 Numerical Computation of the Parameters of Weibull Distribution for the DS Model

For a DS model, assume that,
for lead time l :

$$\mu(l_{sn}) = 4, \quad CV = 0.25, \quad a_3 = 0.7, \quad a_4 = 0.3 \quad (4.10)$$

for demand d :

$$\mu(d_n) = 10, \quad \sigma(d_n) = 10, \quad a_3 = 2 \quad (4.11)$$

Substituting these data into equations 4.4-4.8 to calculate p , q , a , and b for $f(x)$, we get:

$$p = 1.631, \quad q = 4.533, \quad a = 2.394 \quad b = 8.462 \quad (4.12)$$

Using equations 3.49 and 4.9 to compute the first three raw moments of beta and exponential distributions, respectively, and equations 3.41-3.43 to compute their first three central moments, the first three central moments of the *LTD* distribution can be calculated using equations 3.44-3.46 and fitted to a 3-parameter Weibull distribution. Table 4.2 shows the results.

Table 4.2: Computation of moments and Weibull parameters for the DS model

Raw moments			
	μ_1	μ_2	μ_3
l	4	17	76.7
d	10	200	6,000
Central moments			
	μ_1	μ_2	μ_3
l	4	1	0.7
d	10	100	2,000
x	40	500	11,700
Weibull parameters			
	a	b	c
W	6.621	37.037	1.522

4.1.3 Numerical Computation of the Parameters of a Weibull Distribution for the DSOS Model

For a DSOS model, assume that

for the first shipment's lead time l_1 :

$$\mu(l_{sn1}) = 4, \quad CV = 0.25, \quad a_3 = 0.7, \quad a_4 = 0.3 \quad (4.13)$$

for the second shipment's lead time l_2 :

$$\mu(l_{sn2}) = 6, \quad CV = 0.25, \quad a_3 = 0.7, \quad a_4 = 0.3 \quad (4.14)$$

for demand d :

$$\mu(d_n) = 10, \quad \sigma(d_n) = 10, \quad a_3 = 2 \quad (4.15)$$

Substituting these data into equations 4.4-4.8 to calculate p, q, a, b for $f_1(x)$ and $f_2(x)$, we get:

for the first shipment's lead time l_1 :

$$p = 1.631, \quad q = 4.533, \quad a = 2.394 \quad b = 8.462 \quad (4.16)$$

for the second shipment's lead time l_2 :

$$p = 1.631, \quad q = 4.533, \quad a = 3.592 \quad b = 12.693 \quad (4.17)$$

Although $f_1(x)$ and $f_2(x)$ have different mean and standard deviations, we should mention that p_i and q_i are identical for all $f_i(x)$'s because the assumed a_3 and a_4 are the same, and according to equation 4.6, it is trivial that p and q are independent of μ and σ .

Substituting the results of equations 4.16 and 4.17 into equation 4.3 and then, in equations 3.30-3.34 to compute S_1 and S_2 , we have:

$$S_1 = 0.8743, \quad S_2 = 0.1257 \quad (4.18)$$

Substituting the results of equations 4.16 and 4.17 into equations 3.39 and evaluating the integrals using “*NIntegrate*” function in “*Mathematica 10.0*” to get the first three raw moments of lead time distribution (beta) gives:

4 Evaluation and Results of the Four Strategies

Table 4.3: The first three raw moments of the LT distribution for the DSOS model

	μ_1	μ_2	μ_3
l_{11}	3.805	15.231	64.154
l_{12}	6.206	40.695	281.583
l_{21}	5.354	29.309	163.990
l_{22}	4.565	21.245	100.807

Using Table 4.3 and equations 3.41-3.43 to compute the first three central moments of lead time distribution, we get:

Table 4.4: The first three central moments of the LT distribution for the DSOS model

	μ_1	μ_2	μ_3
l_{11}	3.80	0.750	0.487
l_{12}	6.206	2.176	2.010
l_{21}	5.354	0.641	0.196
l_{22}	4.565	0.406	0.113

Similarly, using equation 4.9 to compute the first three raw moments, and subsequently, using equations 3.41-3.43 to compute the first three central moments of demand distribution (exponential), we get:

Table 4.5: First three raw and central moments of demand distribution in the DSOS model

Raw moments		
μ_1	μ_2	μ_3
10	200	6,000
Central moments		
μ_1	μ_2	μ_3
10	100	2,000

Using Table 4.4 and 4.5, we can now compute the first three central moments of the *LTD* distribution. Therefore, we get:

4.1 Computing the Inputs of the Models

Table 4.6: The first three central moments of the LTD distribution for the DSOS model

	μ_1	μ_2	μ_3
x_{11}	38.053	455.540	10,347.74
x_{12}	62.063	838.217	20,950.43
x_{21}	53.542	599.545	12,828.51
x_{22}	45.650	497.130	10,462.60

Fitting the central moments in Table 4.6 to a 3-parameter Weibull distribution, we have:

Table 4.7: The location, scale and shape parameters of the LTD distribution for the DSOS model

	a	b	c
W_{11}	6.491	34.980	1.506
W_{12}	14.198	53.650	1.701
W_{21}	13.310	45.072	1.690
W_{22}	10.454	39.294	1.617

4.1.4 Numerical Computation of the Parameters of Weibull Distribution for the CD Model

The procedure for computing the parameters of the Weibull distribution in the CD model is similar to the DS model. However, it should be computed for both the DC and retailers.

Given the following parameter values for each retailer n in the CD model: for lead time l :

$$\mu(l_{0n}) = 2, \quad CV = 0.25, \quad a_3 = 0.7, \quad a_4 = 0.3 \quad (4.19)$$

for demand d :

$$\mu(d_n) = 10, \quad \sigma(d_n) = 10, \quad a_3 = 2 \quad (4.20)$$

and, substituting these data into equations 4.4-4.8 to calculate p , q , a , and b for $f(x)$, we have:

$$p = 1.631, \quad q = 4.533, \quad a = 1.197 \quad b = 4.231 \quad (4.21)$$

4 Evaluation and Results of the Four Strategies

Similar to the DS model, and using equations 3.49 and 4.9 to compute the first three raw moments of beta and exponential distributions, respectively, and equations 3.41-3.43 to compute the first three central moments, one can fit these central moments to a 3-parameter Weibull distribution. Therefore, we have:

Table 4.8: Computation of moments and Weibull parameters for retailers in the CD model

Raw moments			
	μ_1	μ_2	μ_3
l	2	4.25	9.587
d	10	200	6,000
Central moments			
	μ_1	μ_2	μ_3
l	2	0.25	0.0875
d	10	100	2,000
x	20	225	4,837.5
Weibull parameters			
	a	b	c
W	1.397	19.965	1.247

Similarly, the parameters of the Weibull distribution for our calculations at the DC are easily achievable. Given the following parameter values for DC in the CD model

for lead time l :

$$\mu(l_{s0}) = 4, \quad CV = 0.25, \quad a_3 = 0.7, \quad a_4 = 0.3$$

for demand d :

$$\mu(d_0) = 150, \quad \sigma(d_0) = 150, \quad a_3 = 2$$

and, substituting these data into equations 4.4-4.8 to calculate p , q , a , and b for $f(x)$, we have:

$$p = 1.631, \quad q = 4.533, \quad a = 2.394 \quad b = 8.462$$

Similar to the procedure for computing the first three raw and central moments of lead time and demand (beta and exponential) distributions, respec-

4.1 Computing the Inputs of the Models

tively, and estimation of Weibull parameters for retailers, for DC we obtain:

Table 4.9: Computation of moments and Weibull parameters for DC in the CD model

Raw moments			
	μ_1	μ_2	μ_3
l	4	17	76.7
d	150	45,000	20,250,000
Central moments			
	μ_1	μ_2	μ_3
l	4	1	0.7
d	150	22,500	6,750,000
x	600	112,500	39,487,500
Weibull parameters			
	a	b	c
W	99.326	555.564	1.522

4.1.5 Numerical Computation of the Parameters of Weibull Distribution for the CDOS Model

In the CDOS model, we have the same input and output for computing the Weibull parameters for retailers as in the CD model. Therefore, for retailers, we have:

Table 4.10: Computation of moments and Weibull parameters for retailers in the CDOS model

Raw moments			
	μ_1	μ_2	μ_3
l	2	4.25	9.587
d	10	200	6,000
Central moments			
	μ_1	μ_2	μ_3
l	2	0.25	0.0875
d	10	100	2,000
x	20	225	4,837.5
Weibull parameters			
	a	b	c
W	1.397	19.965	1.247

4 Evaluation and Results of the Four Strategies

The procedure for computing the Weibull parameters at DC in the CDOS model is similar to the DSOS model. We assume that

for the first shipment's lead time l_1 :

$$\mu(l_{s01}) = 4, \quad CV = 0.25, \quad a_3 = 0.7, \quad a_4 = 0.3$$

for the second shipment's lead time l_2 :

$$\mu(l_{s02}) = 6, \quad CV = 0.25, \quad a_3 = 0.7, \quad a_4 = 0.3$$

for demand d :

$$\mu(d_0) = 150, \quad \sigma(d_0) = 150, \quad a_3 = 2$$

Substituting these inputs into equations 4.4-4.8 to calculate p , q , a , b for $f_1(x)$ and $f_2(x)$, we have:

for the first shipment's lead time l_1 :

$$p = 1.631, \quad q = 4.533, \quad a = 2.394 \quad b = 8.462$$

for the second shipment's lead time l_2 :

$$p = 1.631, \quad q = 4.533, \quad a = 3.592 \quad b = 12.693$$

Therefore, we have:

$$S_1 = 0.8743, \quad S_2 = 0.1257$$

Table 4.11 till 4.14 present the first three raw and central moments for lead time, demand and LTD distributions.

Table 4.11: The first three raw moments of LT distribution for the CDOS model

	μ_1	μ_2	μ_3
l_{11}	3.805	15.231	64.154
l_{12}	6.206	40.695	281.583
l_{21}	5.354	29.309	163.990
l_{22}	4.565	21.245	100.807

4.1 Computing the Inputs of the Models

Table 4.12: The first three central moments of LT distribution for the CDOS model

	μ_1	μ_2	μ_3
l_{11}	3.805	0.750	0.487
l_{12}	6.206	2.176	2.010
l_{21}	5.354	0.641	0.196
l_{22}	4.565	0.406	0.113

Table 4.13: First three raw and central moments of demand distribution in the CDOS model

Raw moments		
μ_1	μ_2	μ_3
150	45,000	20,250,000
Central moments		
μ_1	μ_2	μ_3
150	22,500	6,750,000

Table 4.14: The first three central moments of LTD distribution for the CDOS model

	μ_1	μ_2	μ_3
x_{11}	570.804	102,496.40	34,923,623.47
x_{12}	930.952	188,598.81	70,707,706.01
x_{21}	803.134	134,897.65	43,296,206.65
x_{22}	684.744	111,854.25	35,311,271.28

Fitting the central moments in Table 4.14 to a 3-parameter Weibull distribution, we have:

Table 4.15: The location, scale and shape parameters of LTD distribution for the CDOS model

Weibull parameters			
	a	b	c
W_{11}	97.373	524.710	1.506
W_{12}	212.975	804.747	1.701
W_{21}	199.662	676.087	1.690
W_{22}	156.808	589.418	1.617

4 Evaluation and Results of the Four Strategies

Having determined values of order quantity Q and reorder point R , and using the computed parameters of a Weibull distribution for the DS, DSOS, CD, and CDOS models in this section, one can easily calculate safety stock and expected number of shortages.

4.2 Results

4.2.1 Numerical Analysis with the Basic Parameter Values

In order to evaluate and compare the results of order splitting and consolidated distribution models as well as their integration in a multi-echelon distribution system with the direct shipping model, we used “*Mathematica 10.0*” and conducted numerical experiments for our mathematical models. We ran the function “*NMinimize*” to solve our numerical non-linear optimization problem. “*NMinimize*” used “*Nelder-Mead*” method to deal with the problem.

Throughout this research work, the comparisons that we perform in the context of research questions (*RQ 1-3*) involve the TAC of the DSOS, CD, and CDOS models over the DS model as the reference model. Therefore, we define the Key Performance Indicator (KPI) as “*percentage increase/decrease over the DS model*”.

Table 4.16 displays the summary of the results. The last column in the right hand side represents the KPI. When the value of KPI is negative, it means the model has lower TAC over the DS model. When it is positive, it represents the worse performance of the model over the DS model.

Table 4.16: Optimal solution for the given parameter values

	Total annual cost (\$)	Q_n^* (units)	Q_0^* (units)	R_n^* (units)	R_0^* (units)	% in- crease/decrease over the DS model
DS	4,278,710	384.260	-	97.37	-	-
DSOS	4,312,430	478.288	-	94.41	-	0.788
CD	4,112,210	466.670	7,000.05	60.96	1,460.63	-3.891
CDOS	4,110,440	466.670	7,000.05	60.96	1,416.22	-3.932

The results indicate that the traditional order splitting approach, i.e. direct shipping with order splitting, has 0.788% higher cost than direct shipping

without order splitting model. Approximately 385 units are ordered in the DS model, while the DSOS model requires an order quantity of 479 units, of which nearly 240 units are transited by the first shipment. On the other hand, in the CD model, where the order quantity is not split but a DC coordinates the logistic activities, the total annual cost would be reduced by 3.891 times over the DS model. Moreover, in case of the CDOS model, where there exists a DC between the supplier and the retailers and the order quantity is split, the total annual cost is reduced by 3.932%. The order quantity in the CD and CDOS models is the same. In addition, reorder points in order splitting models are lower than the related non-order splitting models.

Table 4.17 presents the logistics cost elements for all the models. Obviously, the sum of the cost elements for each model should be equal to the related total annual cost in Table 4.16. In the DSOS model, transportation, ordering, and cycle stock costs are higher than the same costs in the DS model. It is only its safety stock cost which is lower than safety stock cost in the DS model.

Table 4.17: The absolute value of logistic cost elements (\$)

	PC	TC	OC	CIC	SSC	ITC
DS	4,106,250	81,965,85	14,248,17	54,036.60	16,136.85	6,075
DSOS	4,106,250	103,184.40	17,170.65	64,446.75	15,303.90	6,075
CD	3,914,630	56,117.50	6,648.21	107,607,60	22,060.43	5,148
CDOS	3,914,630	56,460.20	7,039.28	105,677.10	21,488.93	5,148

On the other side, even though the cycle and safety stock costs in the CD and CDOS models are higher than the DS and DSOS models, the savings from reduction in the purchasing, transportation, ordering and in-transit inventory costs make these strategies favorable. However, it is the purchasing cost that mainly makes the CDOS and CD models more advantageous. In order to prove this argument, one can simply subtract the purchasing cost from the total logistic cost of all models in Table 4.17 and then, make a comparison similar to what we have done in Table 4.18. This table illustrates the results when we include the purchasing cost (as presented in Table 4.16) and when we subtract it from the total annual cost. As it is indicated, the CD and CDOS models perform worse than the traditional DS model even though they have lower transportation, ordering, and in-transit costs. This means that the decreased cost of transportation, ordering, and in-transit elements in the CD and CDOS models over the DS and DSOS models does not compensate for

4 Evaluation and Results of the Four Strategies

the increased cost of cycle and safety inventory when excluding the purchasing cost. Note that these results for the CD and CDOS models can be worse if we exclude quantity discounts from our calculations because the purchasing price and consequently, the inventory carrying cost per unit will be the same as in the DS and DSOS models.

Table 4.18: Total annual logistics cost with and without purchasing cost

	TAC including purchasing cost (\$)	% in- crease/decrease over the DS model	TAC excluding purchasing cost (\$)	% in- crease/decrease over the DS model
DS	4,278,710	-	172,462.47	-
DSOS	4,312,430	0.788	192,966.90	11.889
CD	4,112,210	-3.891	197,581.73	14.565
CDOS	4,110,440	-3.932	197,204.80	14.346

We made this argument just to discuss the importance of quantity discounts in purchasing cost. However, ignoring purchasing cost especially in multi-echelon systems is a great shortcoming in modeling total logistic cost.

4.2.2 Sensitivity Analysis

In order to better understand the impact of integration of consolidated distribution and order splitting on total annual logistics cost, we conducted sensitivity analysis of some important parameters for all the four models. We studied the impact of changes in demand, number of retailers, split proportion, lead time mean, coefficient of variation (CV), and purchasing price on the total annual cost. In the following, this sensitivity analysis is presented.

4.2.2.1 Impact of Demand

We changed the value of demand to 20, 50, 80, and 150 to see how it affects the total annual cost. To do so, we adjusted equation 4.1 for each average demand value. It is not illogical to say that suppliers provide the quantity discount structure based on the demand quantity. Therefore, when the average daily demand is 50 units, for example, we have the following quantity discount piece-wise structure:

$$c = f(Q) = \begin{cases} c = 75.00\$/item & 1 \leq Q \leq 5,000 \\ c = 74.00\$/item & 5,000 \leq Q \leq 15,000 \\ c = 73.00\$/item & 15,000 \leq Q \leq 35,000 \\ c = 71.50\$/item & 35,000 \leq Q \leq 75,000 \\ c = 70.50\$/item & 75,000 \leq Q \leq 130,000 \\ c = 69.00\$/item & 130,000 \leq Q \end{cases} \quad (4.22)$$

Table 4.19 displays the results. Column 4 of this table represents the order quantity at the DC which is the multiplication of order quantity at one retailer by the number of retailers, i.e. $Q_0=Q_nN$, where N is the total number of retailers (here, 15 retailers). Note that in Table 4.19 order quantity of the CD and CDOS models are always equal. This can happen if purchasing price has a piece-wise structure, which is the case in our models. For example, when demand is 50 units/day, order quantity is 2,333.34 units at each retailer and 35,000.1 units at DC, where the purchasing price is \$71.5. The order quantity cannot be 2,333.33 units, otherwise, the order quantity at DC would be 35000 units or lower and this make the purchasing price to fall within the price category of \$73. As there is no order quantity of 2,333.34 units in reality, it means that a retailer should order 2,334 and not 2,333 units.

Looking at the order quantity in the DSOS model also reveals that it is always larger than order quantity in the DS model (Figure 4.1). Furthermore, the reorder point in the DSOS and CDOS models is always smaller than the reorder point in the DS and CD models, respectively. On the other hand, reorder point at retailers in the CD and CDOS models are smaller than in the DS and DSOS models. This means the retailers can provide a better service level when they are supplied by a DC.

4 Evaluation and Results of the Four Strategies

Table 4.19: Impact of different values of demand on total annual cost

Demand = 20 units/day						
	Total annual cost (\$)	Q_n^* (units)	Q_0^* (units)	R_n^* (units)	R_0^* (units)	% in- crease/decrease over the DS model
DS	8,491,580	590.95	-	194.75	-	-
DSOS	8,542,860	736.362	-	188.82	-	0.603
CD	8,201,790	933.34	14,000.10	121.93	2,921.26	-3.412
CDOS	8,200,620	933.34	14,000.10	121.93	2,832.42	-3.426
Demand = 50 units/day						
DS	21,067,600	1,052.44	-	486.87	-	-
DSOS	21,156,000	1,314.58	-	472.17	-	0.419
CD	20,480,500	2,333.34	35,000.10	304.83	7,303.14	-2.786
CDOS	20,469,800	2,333.34	35,000.10	304.83	7,081.06	-2.837
Demand = 80 units/day						
DS	33,605,900	1,419.66	-	779.00	-	-
DSOS	33,722,200	1,419.66	-	756.15	-	0.346
CD	32,750,700	3,733.34	56,000.10	487.73	11,685.00	-2.544
CDOS	32,731,500	3,733.34	56,000.10	487.73	11,329.70	-2.602
Demand = 150 units/day						
DS	62,800,800	2,045.45	-	1,460.63	-	-
DSOS	62,967,800	2,715.82	-	1,423.55	-	0.266
CD	61,403,200	7,000.01	105,000.15	914.49	21,909.40	-2.225
CDOS	61,366,600	7,000.01	105,000.15	914.49	21,243.20	-2.283

Comparing the results with Table 4.16, it is clear that the performance of the DSOS model is worse than DS model (Figure 4.2). We realized the main reason is that transportation cost plays a dominant role, so that for demand = 10 units/day, the transportation cost of \$1.885 per unit in the DSOS model compared to \$1.497 per unit in the DS model strongly influences the results (Table 4.20).

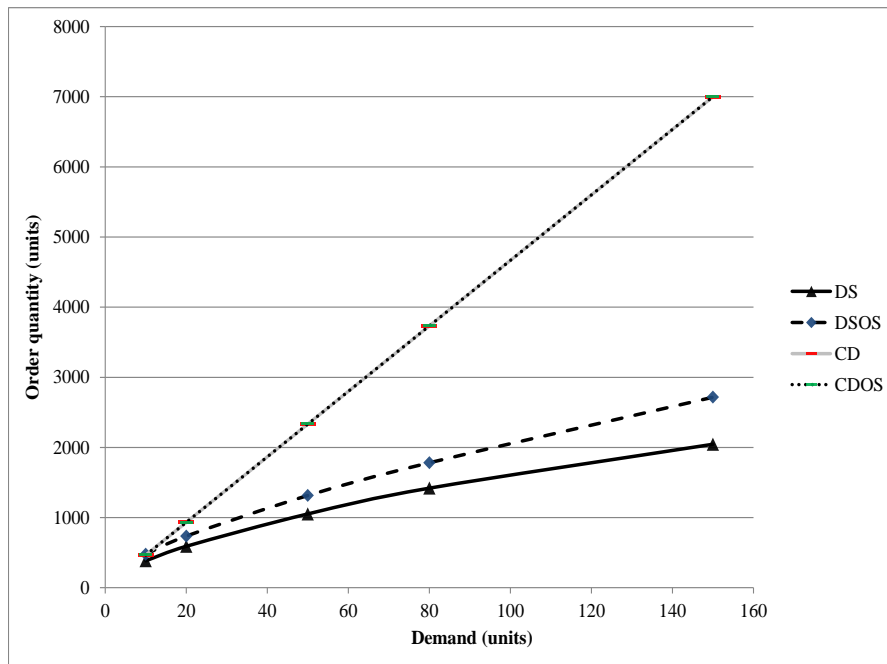

Figure 4.1: Order quantity for different values of demand

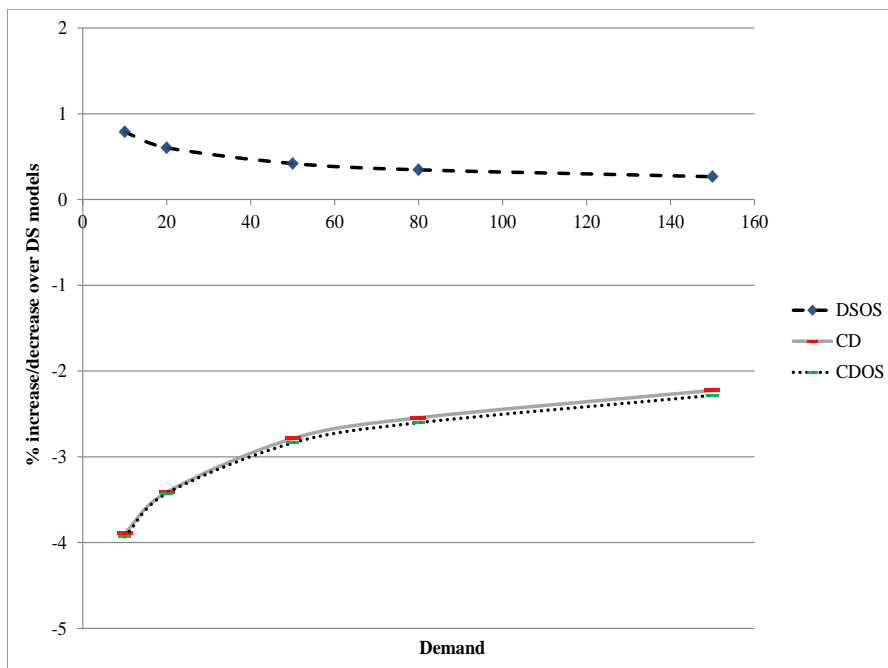

Figure 4.2: Impact of change in demand value on TAC

4 Evaluation and Results of the Four Strategies

Table 4.20: Transportation cost per unit for different values of demand

	10	20	50	80	150
DS	1.497	1.215	0.918	0.794	0.665
DSOS	1.885	1.528	1.154	0.995	0.811
CD	1.025	0.879	0.828	0.796	0.797
CDOS	1.031	0.910	0.833	0.797	0.798

From Figure 4.3, one can realize that as the value of demand increases, the total transportation cost of the DSOS over the DS model gradually decreases. Therefore, one can say that higher demand values results in lower relative transportation cost of the DSOS over the DS model. However, this decrease is not noteworthy.

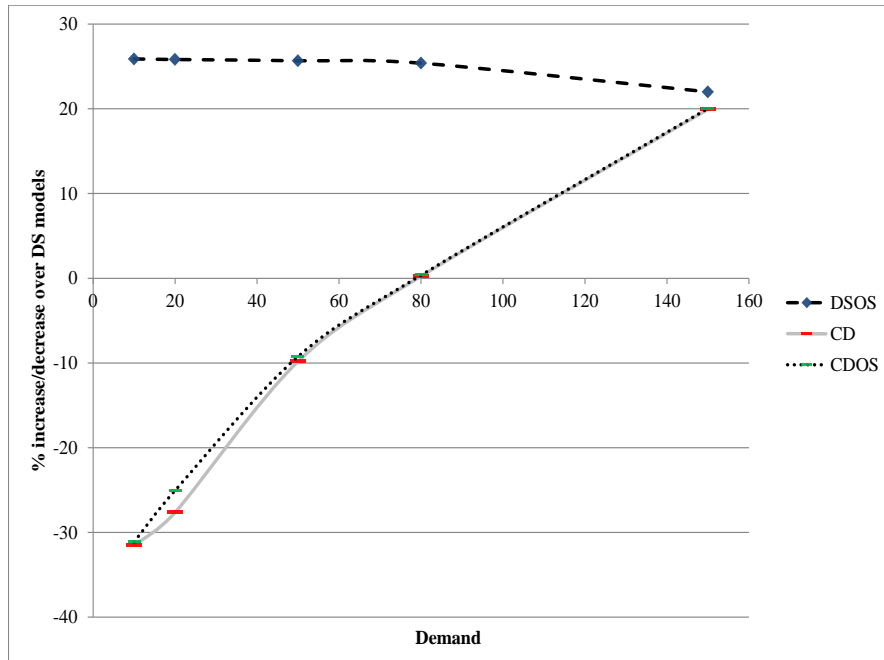

Figure 4.3: % increase/decrease in TC over the DS model for different values of demand

Cycle stock cost is another main reason for higher cost of the DSOS model. Even though the calculation of average cycle inventory with the same order quantity (based on equation 3.22) results in lower inventory cost in the DSOS model, the order quantity of the DSOS system is such higher that it does not cover this reduction in cycle inventory cost. Table 4.21 indicates that cycle stock cost per unit is always higher in the DSOS system than the DS system.

The increase in demand value decreases the cycle stock cost per unit in both the DS and DSOS models. However, the changes are not noteworthy (Figure 4.4).

Table 4.21: Cycle stock cost per unit for different values of demand

	10	20	50	80	150
DS	0.987	0.759	0.541	0.456	0.350
DSOS	1.177	0.894	0.624	0.521	0.414
CD	1.965	1.965	1.965	1.965	1.965
CDOS	1.930	1.930	1.930	1.930	1.930

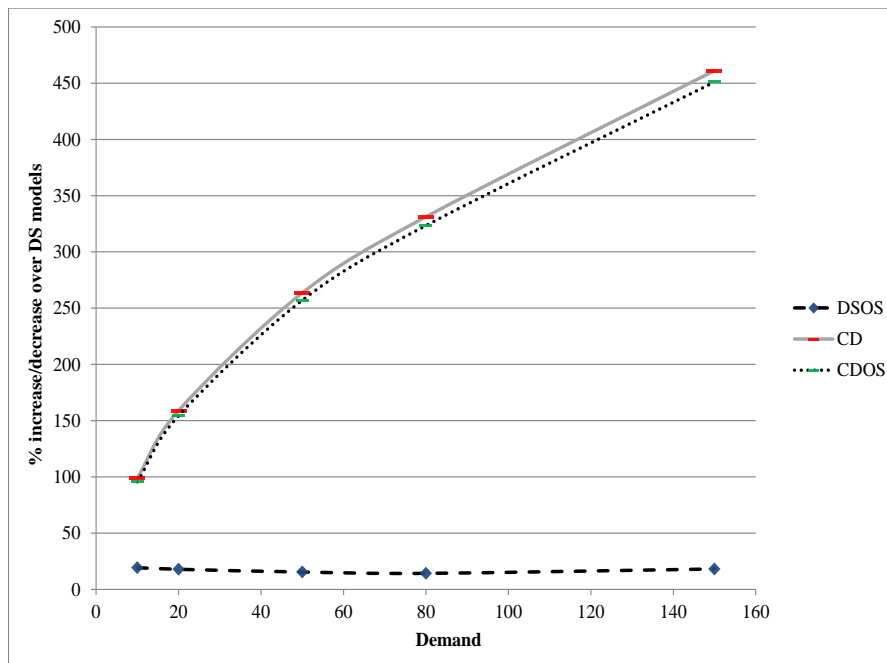

Figure 4.4: % increase/decrease in CSC over the DS model for different values of demand

Ordering cost follows the same pattern as the transportation cost (Table 4.22). Although the DSOS model has a higher order quantity, which reduces the number of order processing per year, the increase in receiving cost in order splitting system (because of the multiplier A) results in higher ordering cost of the DSOS system over the DS system. However, as the value of demand increases, the relative ordering cost of the DSOS model over the DS model decreases (Figure 4.5).

4 Evaluation and Results of the Four Strategies

Table 4.22: Ordering cost per unit for different values of demand

	10	20	50	80	150
DS	0.260	0.169	0.095	0.070	0.049
DSOS	0.314	0.204	0.114	0.084	0.055
CD	0.121	0.061	0.024	0.015	0.008
CDOS	0.129	0.064	0.026	0.016	0.009

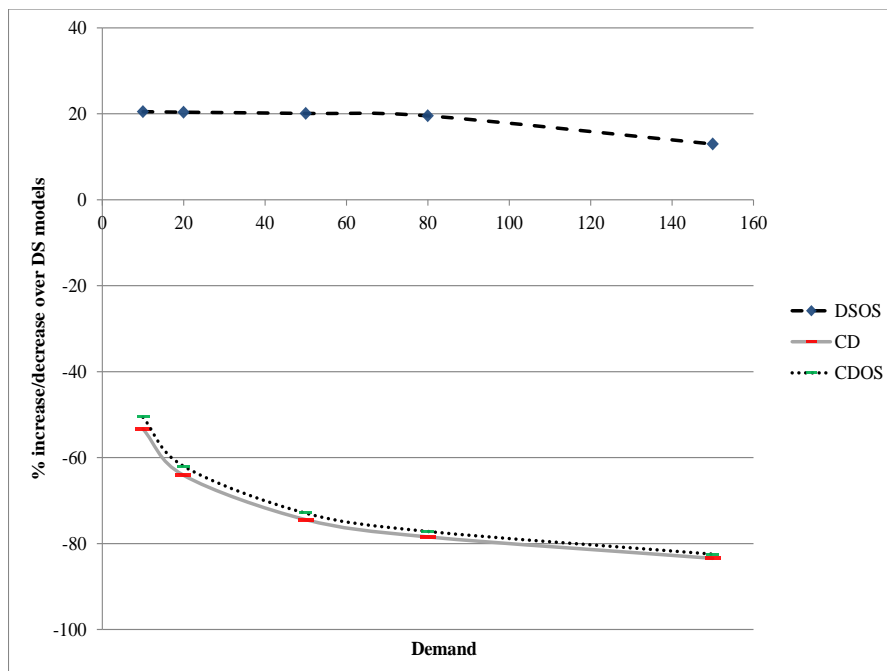

Figure 4.5: % increase/decrease in OC over the DS model for different values of demand

Figure 4.2 illustrates that both the CD and CDOS models perform much better than the DS system. By looking at logistic cost elements, we realized that this is because of the purchasing, ordering, and transportation costs. Purchasing cost comprises the main share of TAC (e.g. more than %90 when demand equals 10 units/day). Therefore, even a small decrease in purchasing price results in huge savings in TAC. Ordering cost has also a lower rate in the CD and CDOS models over the DS model (Table 4.22).

Transportation cost is also lower in the CD and CDOS models for the basic demand value. When the demand is 10 units/day, the transportation cost per unit is \$1.025 and \$1.031 for the CD and CDOS models, respectively (Table 4.20). This indicates the influence of demand consolidation on transportation

cost at the DC.

According to Table 4.19 and Figure 4.2, as the value of demand increases the advantage of the CD and CDOS models over the DS model decreases. We did a simple computation of the percentage increase/decrease of purchasing cost in the CD and CDOS models over the DS model and realized that it is -4.67% for both models for all demand values (Table 4.23). By looking at the order quantity of the DS and DSOS models for all values of demand, one realizes that they always fall between the first intervals of quantity discount structure which results in purchasing price of \$75. The order quantity of the CD and CDOS models also always lies in the fourth interval which has the purchasing price of \$71.5. Therefore, the decrease in the total logistic cost of the CD and CDOS models over the DS models is not definitely due to the purchasing cost.

Table 4.23: % increase/decrease in PC over the DS model for different values of demand

	10	20	50	80	150
DSOS	0	0	0	0	0
CD	-4.666	-4.666	-4.666	-4.666	-4.666
CDOS	-4.666	-4.666	-4.666	-4.666	-4.666

However, the increase in average daily demand decreases the advantage of order consolidation via the distribution center such that the transportation cost of the CD and CDOS models over the DS model are higher when demand equals 80 and 150 units/day. Figure 4.6 displays the decrease in transportation cost per unit in our four models. It illustrates that the slope of the DS and DSOS curves is steeper than the CD and CDOS curves. The reason is clear. When we have larger quantities, the greater shipment weight causes lower transportation unit cost. To show it, we did a simulation of the transportation cost formula (equation 4-33) for LTL (Figure 4.7) to illustrates the changes in transportation cost for order quantity between 20 and 1200 units ($w = 22$ lb., $Z = 850$).

4 Evaluation and Results of the Four Strategies

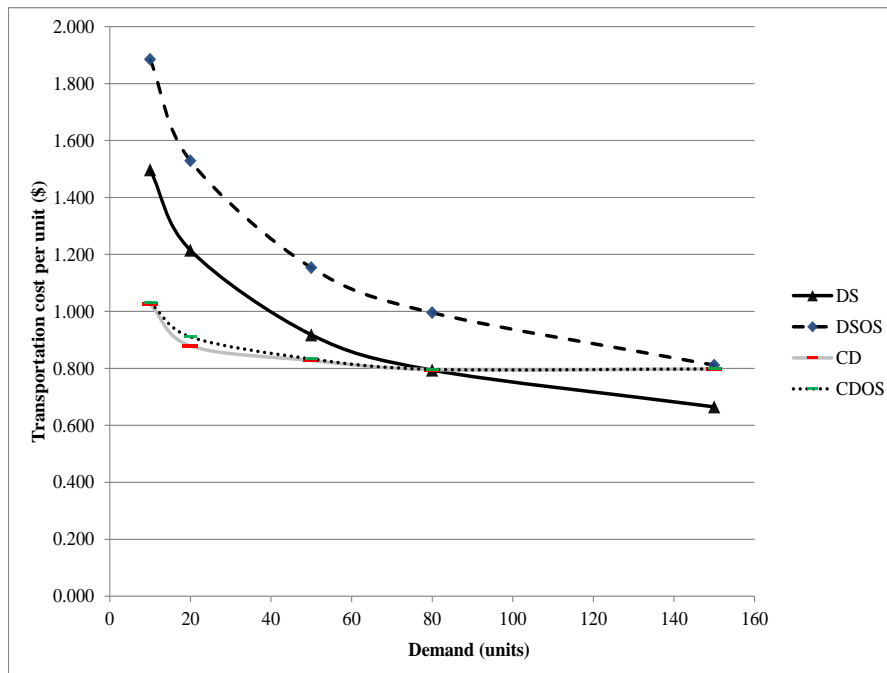

Figure 4.6: Transportation cost per unit for different values of demand

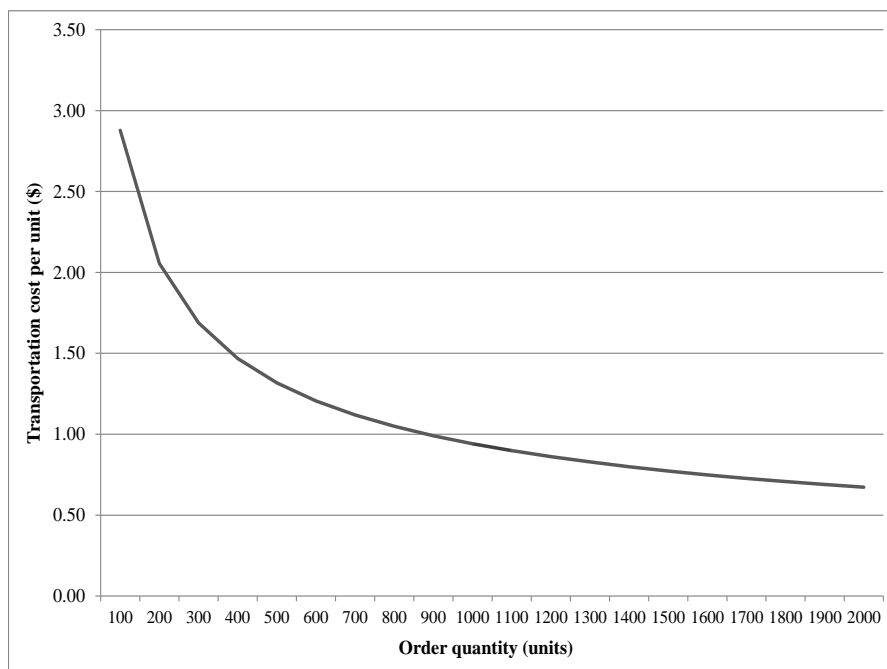

Figure 4.7: Simulation of transportation cost per unit for LTL shipments

The negative exponential curve in Figure 4.7 is the usual transportation unit cost curve which has been represented in many research works for LTL

shipments. However, when the shipment is larger than a FTL, it is then carried by x number of FTL and possibly one LTL shipment. In this case, based on equations 3.3 and 3.4, the simulation of per unit transportation cost is as in Figure 4.8.

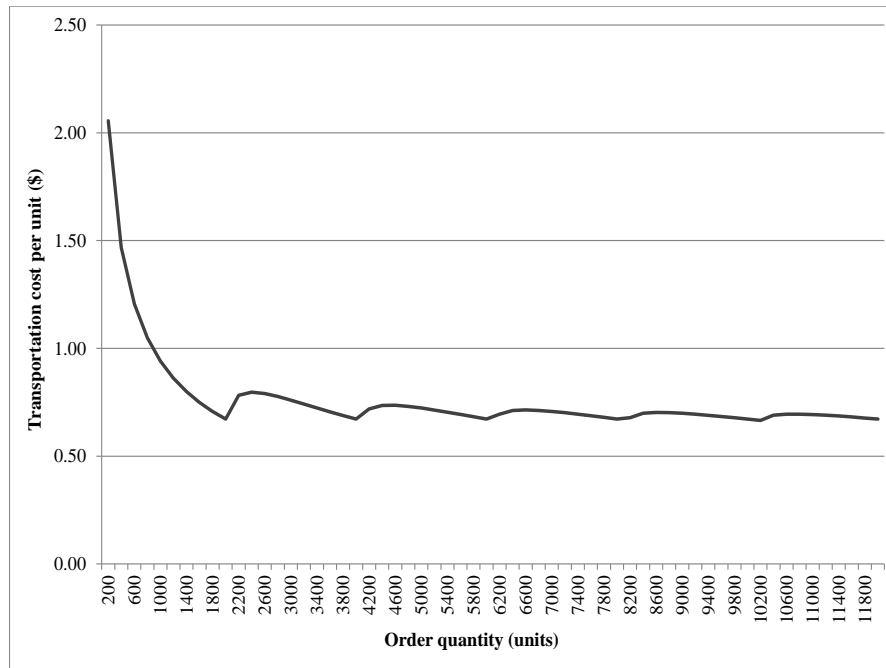

Figure 4.8: Simulation of transportation cost per unit for FTL and LTL shipments

In this figure, the curve has a negative exponential shape till approximately $Q = 2000$ units ($45000/22 = 2045$ units), which is the limit for a LTL shipment. However, from this point on, it has a cyclical trend and becomes more flat as the order quantity increases.

The results also show that a CDOS system slightly performs better than a CD system for the given demand values. This is related to cycle and safety stock costs. Figure 4.9 shows that cycle stock cost of the CDOD model is always lower than the CD model. The same applies to safety stock cost (Figure 4.10).

4 Evaluation and Results of the Four Strategies

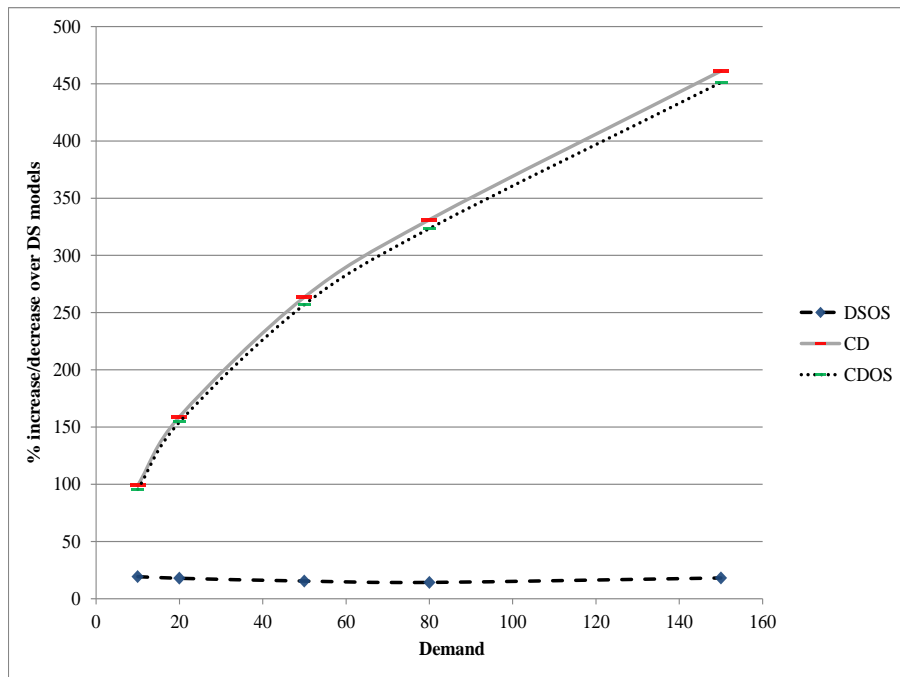

Figure 4.9: % increase-decrease in CSC over the DS model for different values of demand

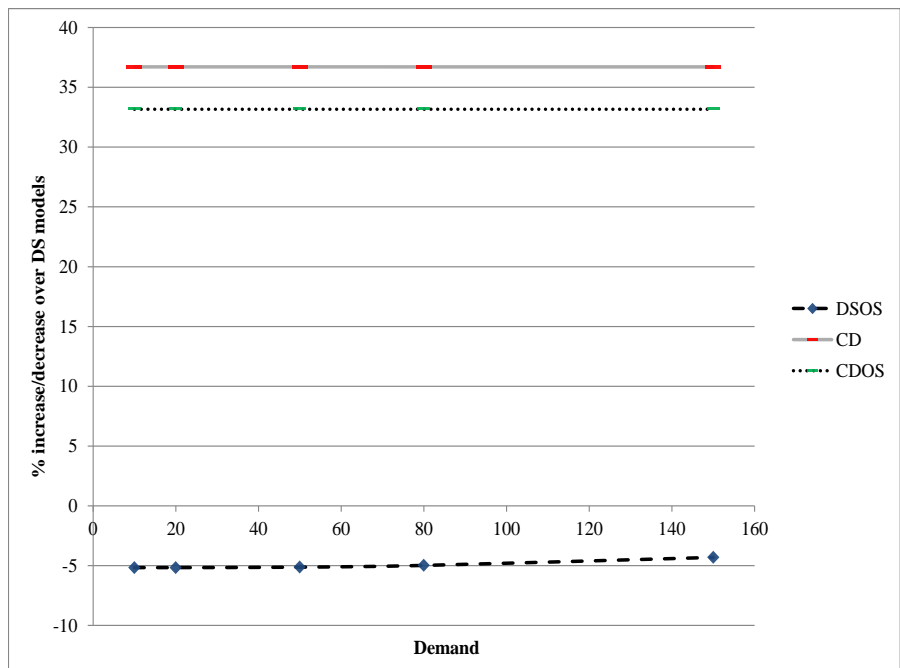

Figure 4.10: % increase/decrease in SSC over the DS model for different values of demand

4.2.2.2 Impact of Number of Retailers

In order to realize the impact of changes in number of retailers on total annual cost, we did a sensitivity analysis when we have 50, 100, 200 and 500 retailers. Table 4.24 presents the results.

Table 4.24: Impact of number of retailers on total annual cost

No. of retailers = 50						
	Total annual cost (\$)	Q_n^* (units)	Q_0^* (units)	R_n^* (units)	R_0^* (units)	% in- crease/decrease over the DS model
DS	14,262,400	384.260	-	97.37	-	-
DSOS	14,374,800	478.287	-	94.41	-	0.788
CD	13,261,500	520.010	26,000.50	60.96	4,868.76	-7.017
CDOS	13,256,600	520.010	26,000.50	60.96	4,720.71	-7.052
No. of retailers = 100						
DS	28,524,700	384.260	-	97.37	-	-
DSOS	28,749,500	478.287	-	94.41	-	0.788
CD	26,227,900	260.001	26,000.10	60.96	9,737.52	-8.052
CDOS	26,218,200	260.001	26,000.10	60.96	9,441.41	-8.086
No. of retailers = 200						
DS	57,049,500	384.260	-	97.37	-	-
DSOS	57,499,100	478.287	-	94.41	-	0.788
CD	52,345,600	163.636	32,727.20	60.96	19,475.00	-8.245
CDOS	52,323,100	184.091	36,818.20	60.96	18,882.80	-8.284
No. of retailers = 500						
DS	142,624,000	384.260	-	97.37	-	-
DSOS	143,748,000	478.288	-	94.41	-	0.788
CD	130,860,000	159.545	79,772.50	60.96	48,687.60	-8.248
CDOS	130,787,000	171.818	85,909.00	60.96	47,220.80	-8.299

Trivially, changes in number of retailers do not affect the DS and DSOS models. Furthermore, comparing the results with Table 4.16, one realizes that an increase in the number of retailers drastically improves the results of the CD and CDOS models over the DS model. However, there is a limit for this improvement. When the number of retailers is 100 or more, the improvement is very small (Figure 4.11).

4 Evaluation and Results of the Four Strategies

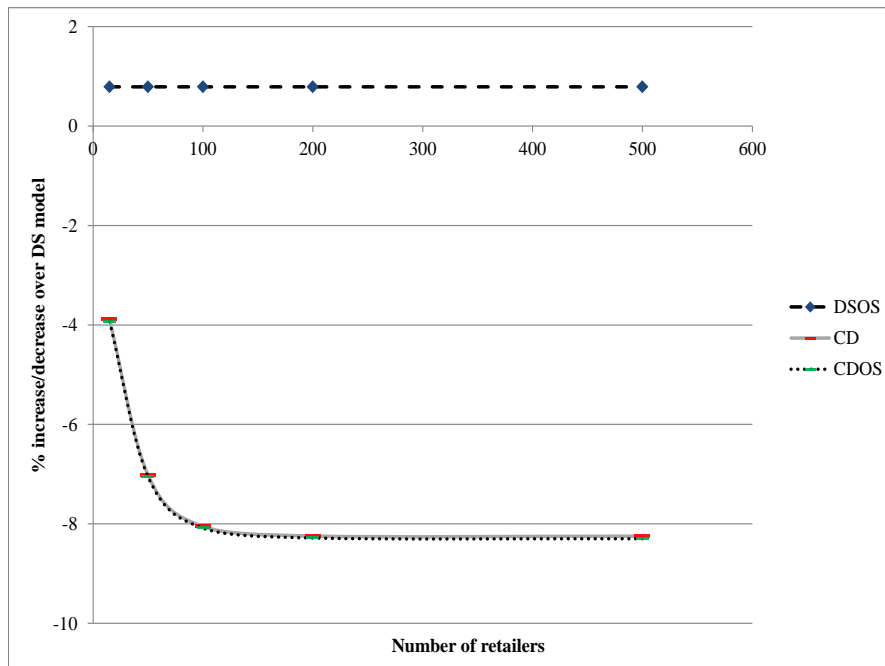

Figure 4.11: Impact of change in number of retailers on TAC

The order quantity always remains the same in the DS and DSOS models. Nevertheless, there is an increase in order quantity of the CD and CDOS models when retailers are 50, but from this point on, the order quantity decreases (Figure 4.12). In fact, by increasing the number of retailers from 15 to 50, the buyers in both the CD and CDOS models can benefit from lowest purchasing price (\$69) if order quantity is larger than 520 units ($520.01 \times 50 > 26000$). This results in great savings. When the number of retailers is 100, any value of order quantity greater than 260 units ($26000 \div 100 = 260$) satisfies this situation. When retailers are 200 and 500, it is sufficient if order quantity is higher than 130 ($26000 \div 200$) and 52 ($26000 \div 500$) units, respectively. However, the optimal order quantity of the CD and CDOS models are higher than these two values of demand. Generally, except for the case of 50 retailers, the order quantity represents a decreasing trend (Figure 4.12). Similar to our previous results, reorder point of order splitting model is always lower than the related non-order splitting model.

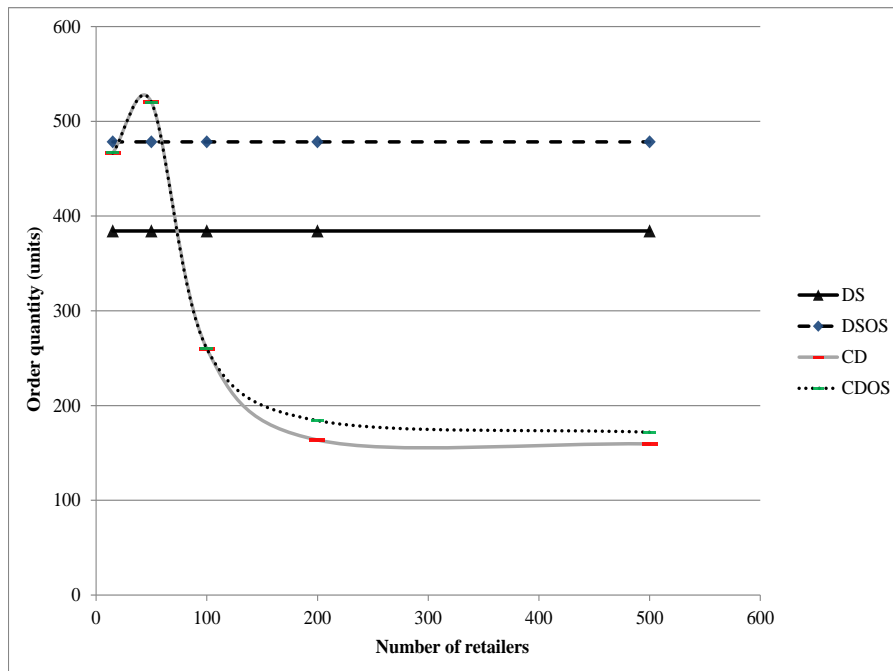

Figure 4.12: Order quantity for different number of retailers

We did a detailed analysis to realize the trend in Figure 4.11. From this analysis, we realized that the main reason of the drastic change in TAC of the CD and CDOS models over the DS model is purchasing cost. When the number of retailers is 15, the purchasing price is \$71.5 per unit. However, the purchasing price is \$69 if the number of retailers is increased to 50. Higher number of retailers results in the purchasing price of \$69/unit. Hence, great savings in purchasing cost, as the main logistic cost element, are achieved. Figure 4.13 shows the trend for purchasing cost for different number of retailers.

4 Evaluation and Results of the Four Strategies

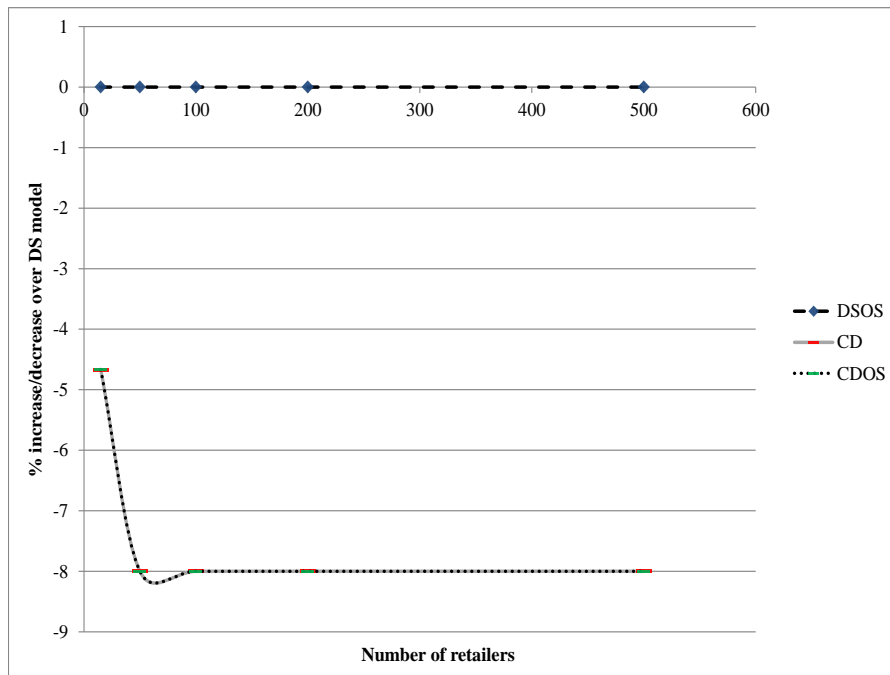

Figure 4.13: % increase/decrease in PC over the DS model for different number of retailers

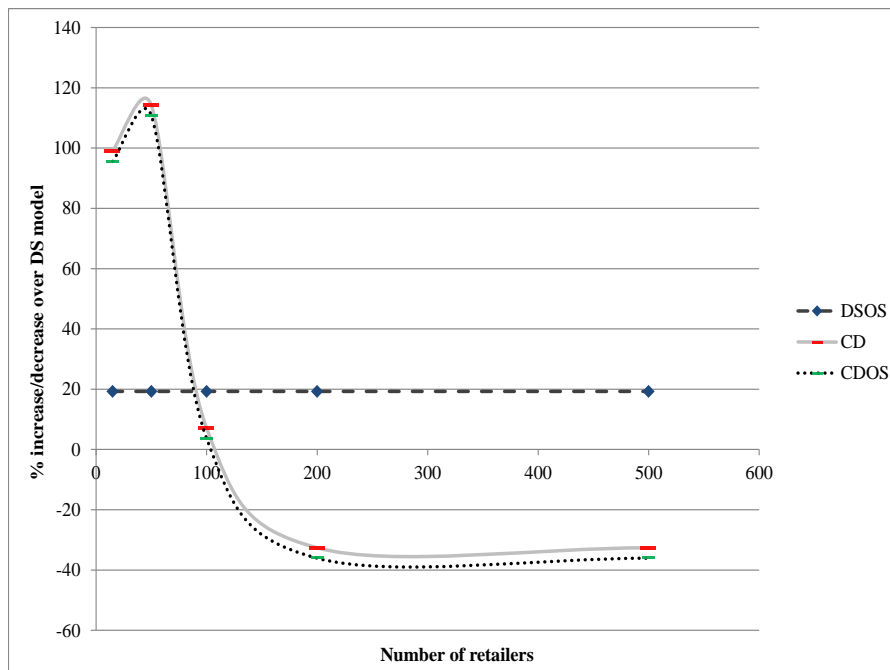

Figure 4.14: % increase/decrease in CSC over the DS model for different number of retailers

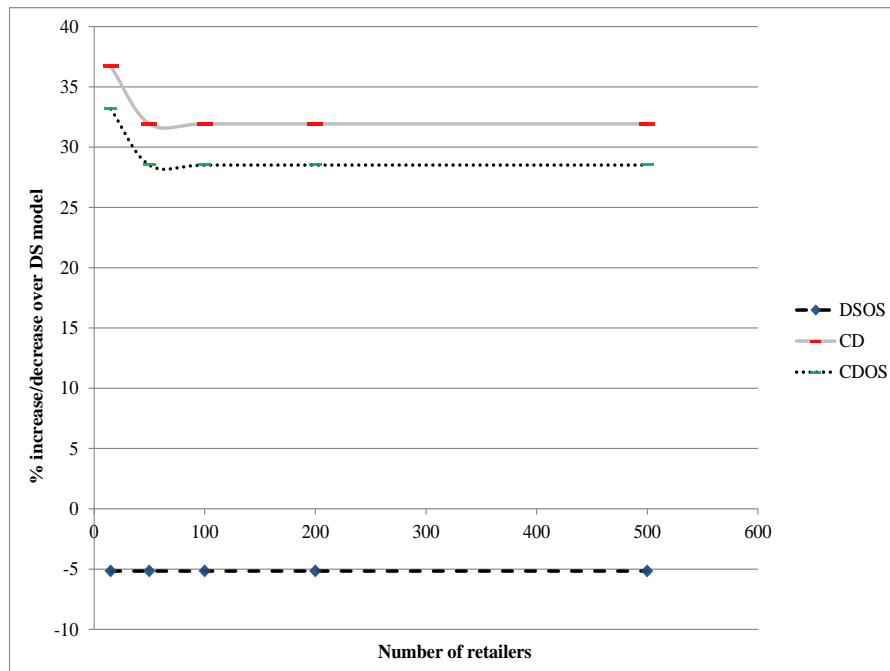

Figure 4.15: % increase/decrease in SSC over the DS model for different number of retailers

The other reasons of the decrease in TAC include the decrease in cycle and in-transit stock costs. In addition, we realized that the advantage of transportation cost and ordering cost of the CD and CDOS models over a DS model decreases as the number of retailers increases. Following the decrease in order quantity for higher number of retailers, the decrease or increase in these costs can be justified. Consequently, the trade-off is, on one hand, between purchasing, cycle stock and in-transit stock costs, and on the other hand, the transportation and ordering costs.

Again, we see that the CDOS model marginally performs better than the CD model. This is due to cycle stock and safety stock costs (Figure 4.14 and 4.15). Except the cycle and safety stock cost elements, we did not find major differences between other cost elements of the CD and CDOS models.

4.2.2.3 Impact of Split Proportion

We changed the split proportion from %50-%50 to %10-%90, %30-%70, %70-%30, and %90-%10 to realize the impact of changes in split proportion on the total annual cost. This is presented in Table 4.25.

4 Evaluation and Results of the Four Strategies

Table 4.25: Impact of split proportion on total annual cost

Split proportion = 10%-90%						
	Total annual cost (\$)	Q_n^* (units)	Q_0^* (units)	R_n^* (units)	R_0^* (units)	% in- crease/decrease over the DS model
DS	4,278,710	384.260	-	97.37	-	-
DSOS	4,299,220	454.976	-	94.41	-	0.479
CD	4,112,210	466.667	7,000.05	60.96	1460.63	-3.891
CDOS	4,111,830	466.667	7,000.05	60.96	1520.36	-3.900
Split proportion = 30%-70%						
DS	4,278,710	384.260	-	97.37	-	-
DSOS	4,309,130	473.641	-	94.41	-	0.711
CD	4,112,210	466.667	7,000.05	60.96	1460.63	-3.929
CDOS	4,110,580	466.667	7,000.05	60.96	1416.21	-3.891
Split proportion = 70%-30%						
DS	4,278,710	384.260	-	97.37	-	-
DSOS	4,311,380	473.641	-	94.41	-	0.763
CD	4,112,210	466.667	7,000.05	60.96	1460.63	-3.891
CDOS	4,112,120	466.667	7,000.05	60.96	1416.21	-3.893
Split proportion = 90%-10%						
DS	4,278,710	384.260	-	97.37	-	-
DSOS	4,303,720	454.976	-	94.41	-	0.584
CD	4,112,210	466.667	7,000.05	60.96	1460.63	-3.891
CDOS	4,113,630	466.667	7,000.05	60.96	1420.27	-3.858

As the order quantity is only split for the DSOS and CDOS models, we computed the results for these models (Figure 4.16). The results of the DSOS model over the DS model represent that the optimal total annual cost is achieved when the majority of the order quantity is allocated to the second shipment. These results show a concave shape, meaning that when order quantity is equally split (%50-%50), it has the worst performance. Generally, the more the order quantity is allocated to either of first or second shipment, the better the performance of the DSOS model. However, it also performs better if more than 50 percent of order quantity is allocated to the second shipment, compared to the case where the majority of order quantity is delivered by the first shipment.

The CDOS model behaves conversely. The best performance over a DS model is achieved when the order quantity is exactly split in two equal ship-

ments. Generally, the more the order quantity is allocated to either of first or second shipment, the worse the performance of the CDOS model. Similar to the DSOS model, when more than half of the order quantity is allocated to the second shipment, the performance of the CDOS model over the DS model is improved compared to the case where first delivery takes more order quantity.

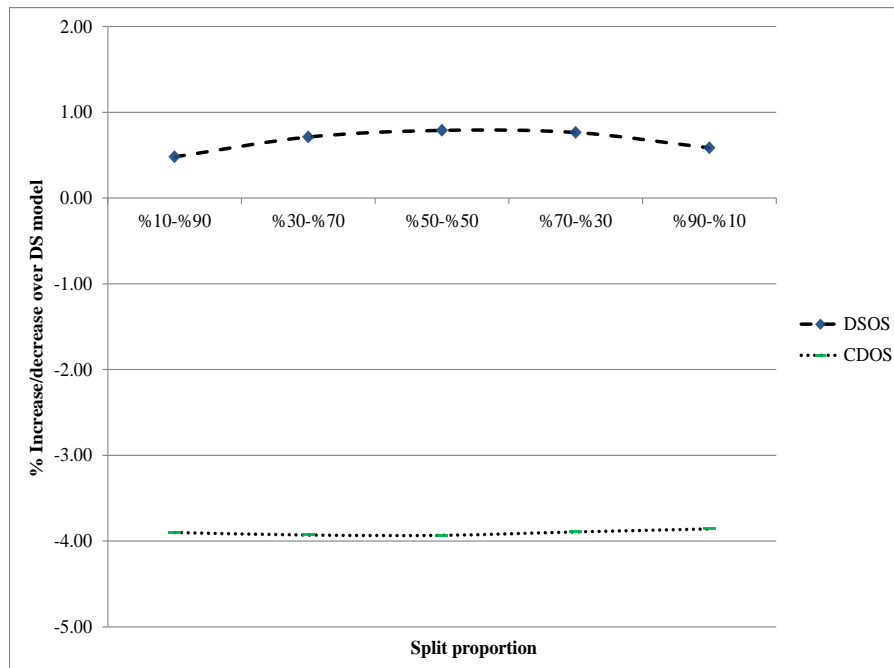

Figure 4.16: Impact of change in split proportions on TAC

The order quantity of a DSOS model changes when we do split proportion analysis and, its curve follows the same trend as the total annual cost curve. In other words, when order quantity is split evenly, order quantity is the largest. However, the order quantity of the CDOS model is always the same. Figure 4.17 represents the case.

The reorder point of order splitting model is always smaller than the related non-order splitting model. There is only one exception and this is when split proportion is %10-%90 in the CDOS model compared to the CD model. This is not surprising considering that only a small proportion of order quantity, i.e. 10 percent, is shipped by the first delivery.

Having a more detailed look at the results, one realizes that the decrease in total cost of the DSOS model for split proportions of %10-%90 is largely due to the decrease in transportation as well as cycle stock cost. It can be more cost beneficial to deliver higher amounts of an order quantity in a shipment,

4 Evaluation and Results of the Four Strategies

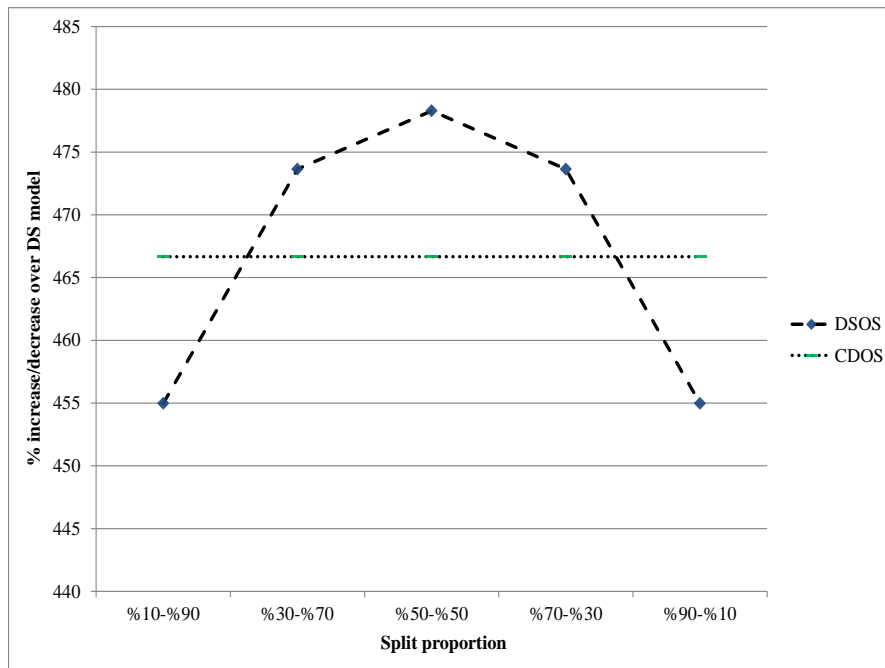

Figure 4.17: Order quantity for changes in split proportion

e.g. %90, than to split and transport two equal shipments (Figure 4.18). Furthermore, according to equation 3.22, an order splitting system has less cycle stock if more units are allocated to the second shipment (Figure 4.19).

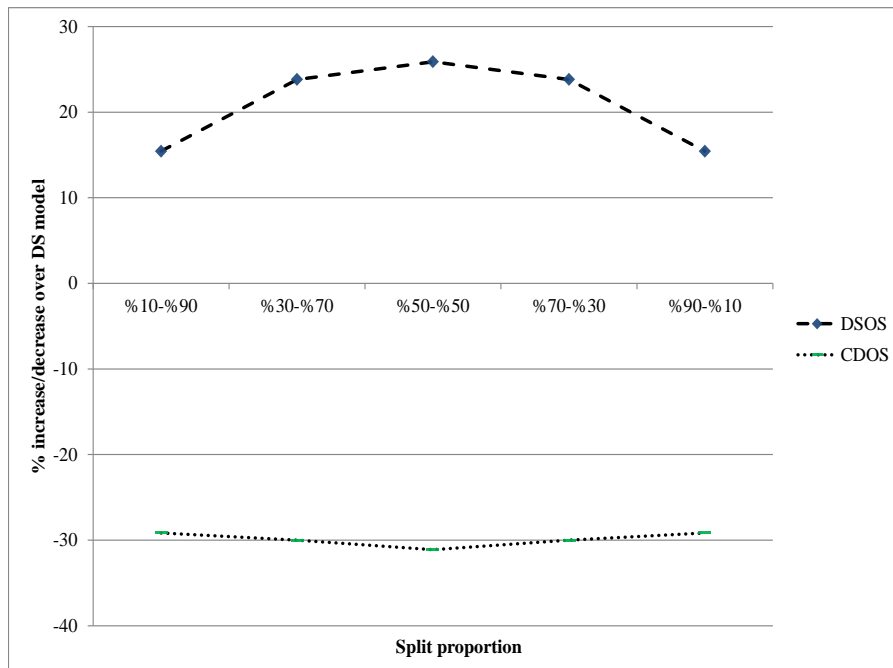

Figure 4.18: % increase/decrease in TC over the DS model for different split proportions

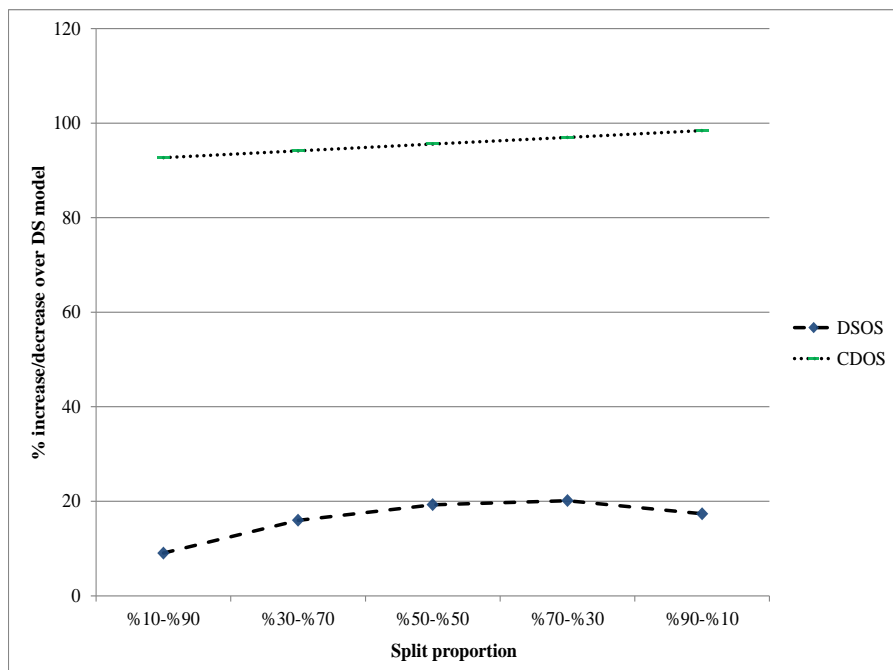

Figure 4.19: % increase/decrease in CSC over the DS model for different split proportions

4 Evaluation and Results of the Four Strategies

For the CDOS model, it is the transportation cost which causes the order split proportion of %50-%50 to have the lowest cost (Figure 4.18). This is due to the decrease in the transportation cost between supplier and DC, while the transportation cost between DC and retailers are the same and does not change with changes in split proportion. According to Figure 4.8, if a large quantity is evenly split, the shipment price per unit still stands in low freight rates as the curve has a gentle slope for high shipment weights. However, if it is split in one small and one large shipment, the shipment rate per unit for the small shipment may be high.

4.2.2.4 Impact of Lead Time Mean

The results of the sensitivity analysis of lead time are presented in Table 4.26. We changed the lead time from 4 to 3, 5 and 6 days. Therefore, in case of order splitting, the second shipment arrives after 5, 7, and 8 days, respectively. When average lead time increases, the relative TAC of the DSOS model over the DS model decreases. Moreover, the relative advantage of the CD and CDOS models over the DS model increases (Figure 4.20). The order quantity does not change for any of the models, but reorder points in order splitting models are smaller than the reorder point in the related non-order splitting models.

The percentage decrease in total annual cost of the DSOS model over the DS model is related to decrease of safety stock cost (Figure 4.21). The value of other cost elements does not change. On the other hand, the percentage decrease in total annual cost of the CD and CDOD models is related to the decrease of safety stock and in-transit stock costs. This is because lead time directly impacts safety stock and in-transit stock (Figure 4.21 and 4.22).

Table 4.26: Impact of lead time mean on total annual cost

Lead time = 3 days						
	Total annual cost (\$)	Q_n^* (units)	Q_0^* (units)	R_n^* (units)	R_0^* (units)	% increase/decrease over the DS model
DS	4,274,510	384,260	-	79.63	-	-
DSOS	4,308,650	478,287	-	78.16	-	0.798
CD	4,109,640	466,667	7,000.05	60.96	1,194.54	-3.857
CDOS	4,108,160	466,667	7,000.05	60.96	1,172.53	-3.891
Lead time = 5 days						
DS	4,282,770	384,260	-	114.61	-	-
DSOS	4,315,900	478,287	-	109.56	-	0.773
CD	4,114,680	466,667	7,000.05	60.96	1,719.20	-3.924
CDOS	4,112,500	466,667	7,000.05	60.96	1,643.43	-3.975
Lead time = 6 days						
DS	4,286,750	384,260	-	131.54	-	-
DSOS	4,319,210	478,287	-	124.12	-	0.757
CD	4,117,090	466,667	7,000.05	60.96	1,973.13	-3.957
CDOS	4,114,460	466,667	7,000.05	60.96	1,861.87	-4.019

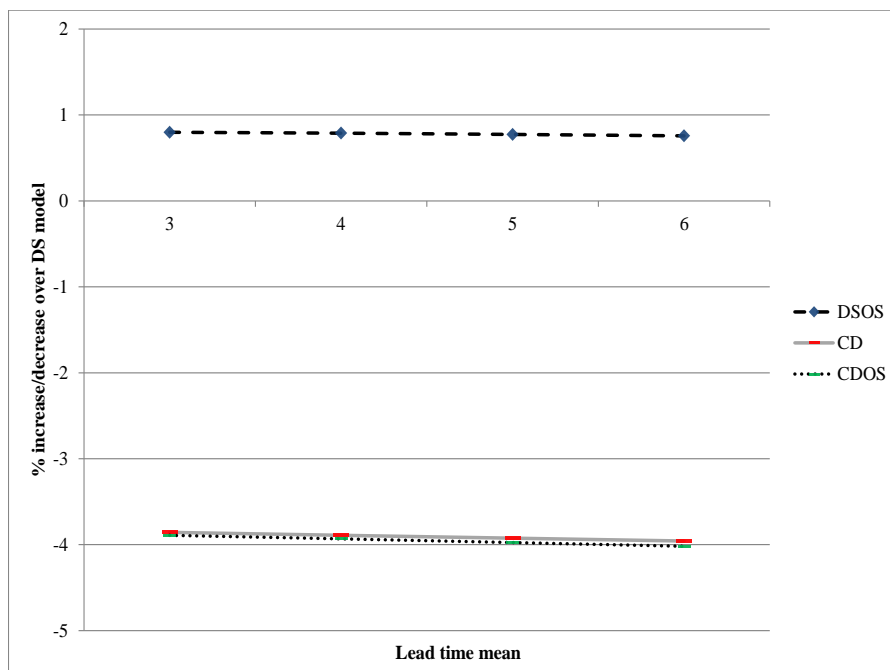

Figure 4.20: Impact of change in lead time mean on TAC

4 Evaluation and Results of the Four Strategies

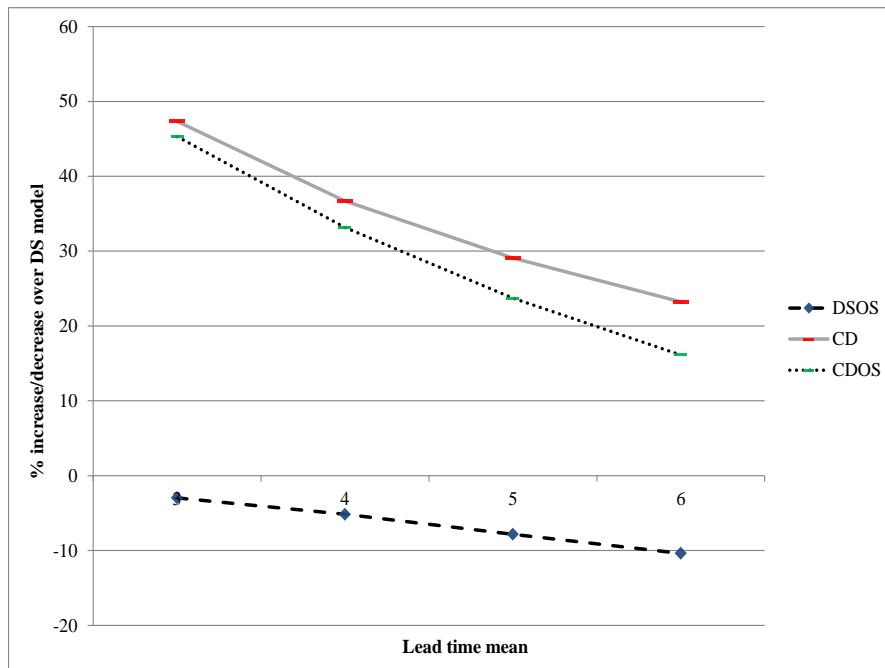

Figure 4.21: % increase/decrease in SSC over the DS model for different lead time mean

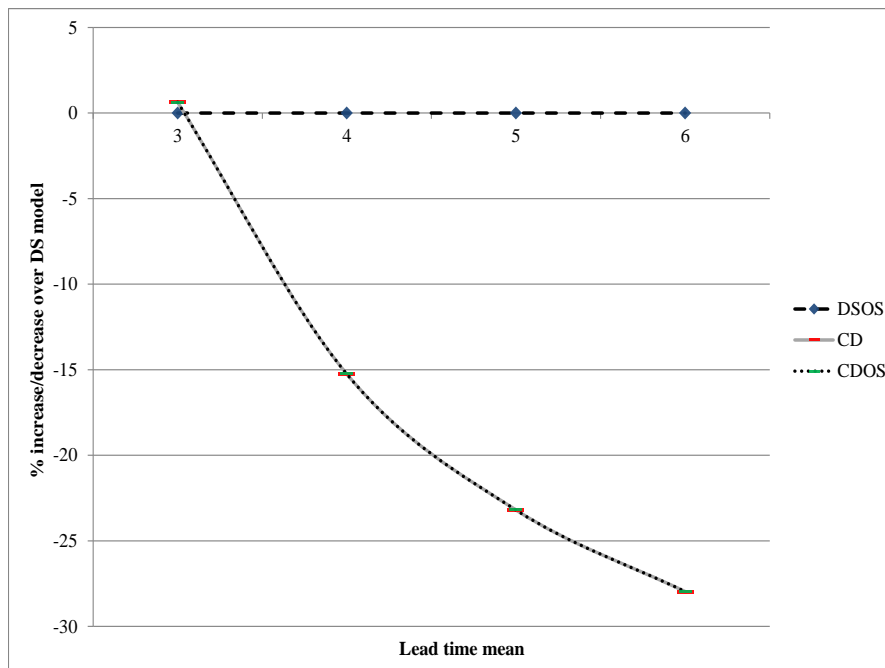

Figure 4.22: % increase/decrease in ITC over the DS model for different lead time mean

In addition, the CDOS model performs better than the CD model. This is because of lower safety stock cost in the CDOS system.

4.2.2.5 Impact of Coefficient of Variation of Lead Time

The Coefficient of Variation (CV) in the base model is 0.25. We changed this value to 0.5 and 1.0 to compute its impact on total annual cost. As shown in Table 4.27 and Figure 4.23, when the CV increases, the performance of the DSOS and CDOS models over the DS model improves but, the advantage of the CD model over the DS model decreases. However, the changes in performance of the CD and CDOS models are not high.

Table 4.27: Impact of coefficient of variation of lead time on total annual cost

CV = 0.5						
	Total annual cost (\$)	Q_n^* (units)	Q_0^* (units)	R_n^* (units)	R_0^* (units)	% in- crease/decrease over the DS model
DS	4,283,300	384.260	-	113.67	-	-
DSOS	4,313,640	478.287	-	98.72	-	0.708
CD	4,117,410	466.667	7,000.05	67.62	1,705.17	-3.872
CDOS	4,112,930	466.667	7,000.05	67.62	1,471.52	-3.977
CV = 1.0						
DS	4,295,320	384.260	-	156.40	-	-
DSOS	4,319,080	478.287	-	118.04	-	0.553
CD	4,130,650	466.667	7,000.05	87.23	2,346.10	-3.833
CDOS	4,122,040	466.667	7,000.05	87.23	1,770.62	-4.034

4 Evaluation and Results of the Four Strategies

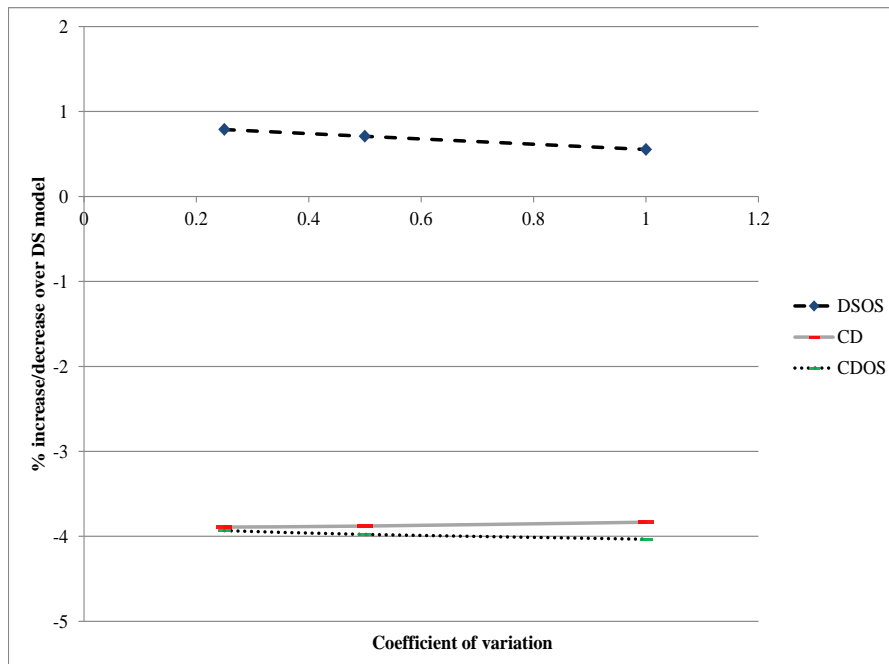

Figure 4.23: Impact of change in Coefficient of Variation (CV) of lead time on TAC

A detailed analysis reveals that the only logistic cost element that is affected by the change in coefficient of variation (CV) is safety stock cost (Table 4.28). As the CV increases, the relative safety stock cost of the DSOS and CDOS models over the DS model decreases. The same applies to the CD model (Figure 4.24). However, compared to the DSOS and CDOS models, the percentage decrease of the CD model over the DS model is not that high and results in a slight increase in total annual cost.

Table 4.28: % increase/decrease in SSC over the DS model for different values of CV

	0.25	0.5	1.0
DSOS	-5.161	-20.290	-32.959
CD	36.708	30.258	23.703
CDOS	33.166	15.746	1.081

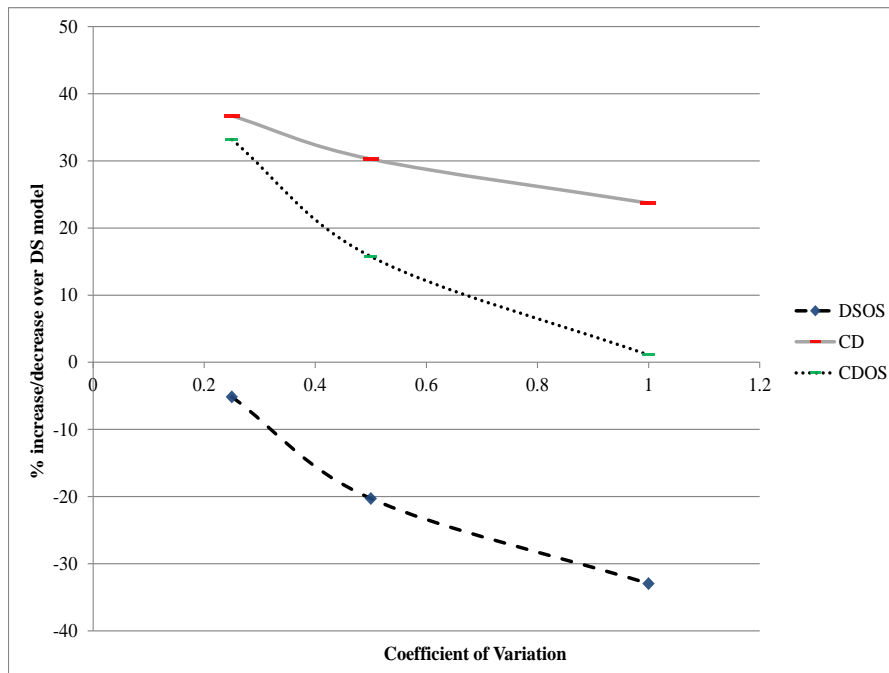

Figure 4.24: % increase/decrease in SSC over the DS model for different values of CV

Similar to our findings in the sensitivity analysis of other parameters, the CDOS model performs better than the CD model for the given values of CV (Figure 4.23).

When the CV changes from 0.25 to 0.5 or 1.0, the order quantity of neither models changes. Again, the reorder points in order splitting models are lower than the reorder points in the related non-order splitting models.

4.2.2.6 Impact of Purchasing Price

Till now, we discussed that the main reason of lower total annual cost of the CD and CDOS models compared to the DS and DSOS models is the aggregation of order quantity of retailers from the supplier to DC and hence, the impact of this aggregation on purchasing price. To better understand the influence of purchasing price, we changed the average purchasing prices in the quantity discount structure (equation 4.1) by dividing each breakpoint price by 10 or multiplying it by 10 and 20. For example, we have the following quantity discount structure when the prices are divided by 10:

4 Evaluation and Results of the Four Strategies

$$c = f(Q) = \begin{cases} c = 7.50\$/item & 1 \leq Q \leq 1,000 \\ c = 7.40\$/item & 1,000 < Q \leq 3,000 \\ c = 7.30\$/item & 3,000 < Q \leq 7,000 \\ c = 7.15\$/item & 7,000 < Q \leq 15,000 \\ c = 7.05\$/item & 15,000 < Q \leq 26,000 \\ c = 6.90\$/item & 26,000 < Q \end{cases} \quad (4.23)$$

The results in Table 4.29 show a decreasing trend for TAC of the DSOS model as the average purchasing price increases. However, the optimal result is not achieved when we have lower or higher purchasing prices in the CD and CDOS models. To further explain, with the new values we assigned to the purchasing price, the advantages of the CD and CDOS models over the DS model decreases for either lower or higher prices (Figure 4.25).

Table 4.29: Impact of purchasing price on total annual cost

Purchasing price divided by 10						
	Total annual cost (\$)	Q_n^* (units)	Q_0^* (units)	R_n^* (units)	R_0^* (units)	% in- crease/decrease over the DS model
DS	473,958	1,651.74	-	97.37	-	-
DSOS	490,340	2,062.70	-	94.41	-	3.456
CD	462,811	1,000.01	15,000.15	60.96	1,460.63	-2.352
CDOS	462,885	1,090.90	16,363.50	60.96	1,416.22	-2.336
Purchasing price multiplied by 10						
DS	41,637,400	96.01	-	97.37	-	-
DSOS	41,690,700	128.99	-	95.33	-	0.128
CD	40,557,200	466.667	7,000.05	60.96	1,460.63	-2.594
CDOS	40,532,900	466.667	7,000.05	60.96	1,416.22	-2.653
Purchasing price multiplied by 20						
DS	83,030,400	64.10	-	97.37	-	-
DSOS	83,109,200	109.60	-	97.75	-	0.095
CD	81,051,600	466.667	7,000.05	60.96	1,460.63	-2.383
CDOS	81,002,300	466.667	7,000.05	60.96	1,416.22	-2.443

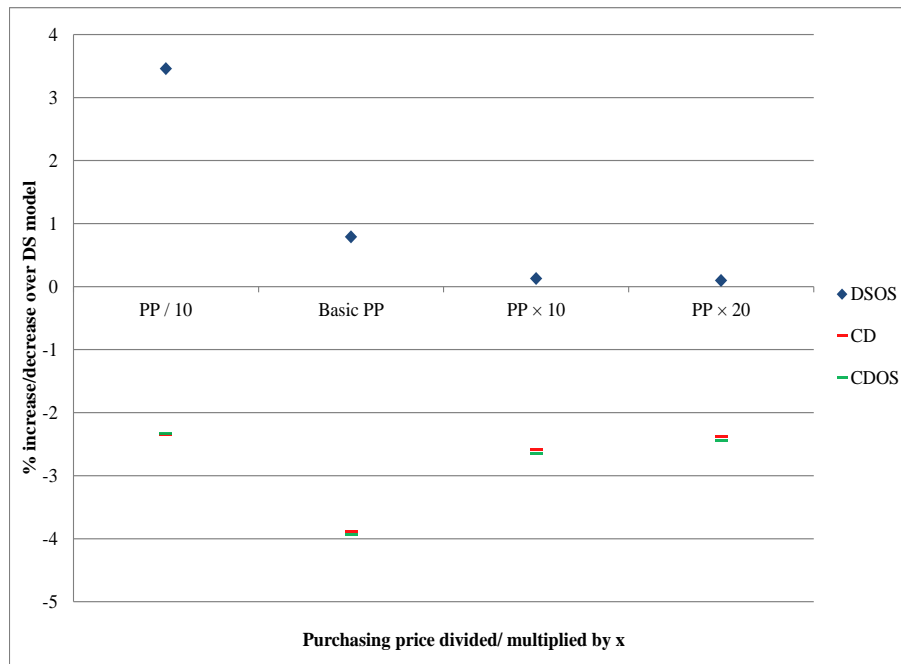

Figure 4.25: Impact of change in purchasing price on TAC

With higher purchasing prices, the order quantity of the DS and DSOS models decreases. However, for the CD and CDOS models, it first decreases but then remains the same (Figure 4.26). On the other hand, except for the case where the basic average purchasing price is multiplied by 20, the reorder points of order splitting models are lower than the related non-order splitting models.

We did a detailed analysis to understand changes in total annual cost. During this process, we realized that the changes in TAC are not due to purchasing cost. In the DSOS model, the purchasing cost is always equal to purchasing cost of the DS model. The same applies to the CD and CDOS models. In the CD and CDOS models, the percentage decrease over the DS model is approximately %4.7 for all given values of average purchasing price (Table 4.30). This result shows that the purchasing price does not directly impact the relative value of TAC of the DSOS, CD and CDOS models over the DS model. However, as we discuss below, it influences other logistic cost elements.

The results indicate that the transportation and ordering costs of the DSOS, CD and CDOS models have a decreasing trend over the DS model as the average purchasing price decreases (Figure 4.27 and 4.28).

4 Evaluation and Results of the Four Strategies

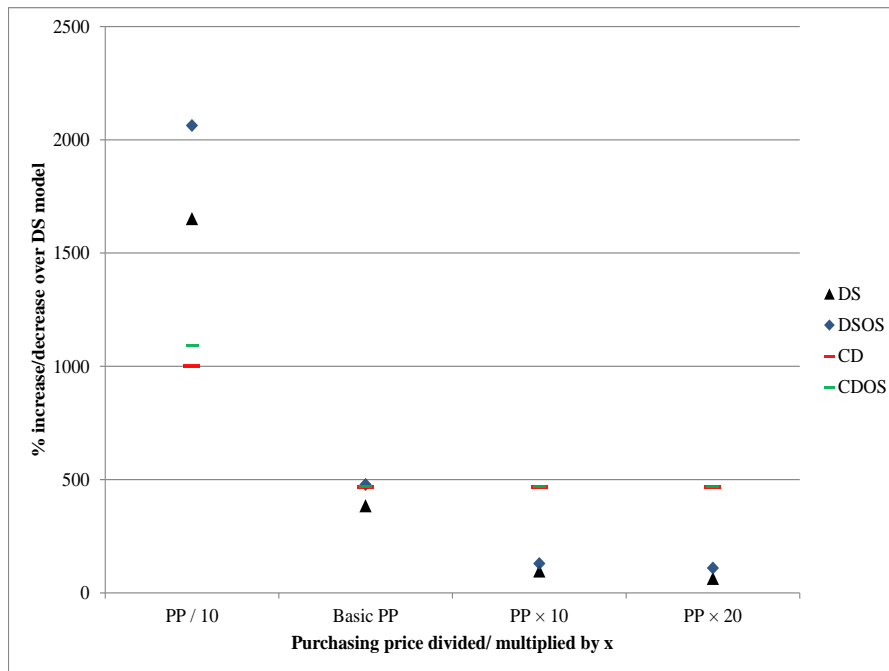

Figure 4.26: Order quantity for changes in purchasing price

In addition, the relative cycle cost of the DSOS model over the DS model gradually decreases as well with the increase in average purchasing price. The only exception is for the case where average purchasing price is multiplied by 20. This is because the order quantity of the DS model at this point does not decrease proportional to the order quantity of the DSOS system.

On the other hand, cycle stock cost in the CD and CDOS models significantly increases with the increase in average purchasing price (Figure 4.29). Therefore, the trade-off is between transportation and ordering costs, on the one hand, and cycle stock cost, on the other hand.

Table 4.30: % increase/decrease in PC over the DS model for different purchasing prices

	PP divided by 10	PP multiplied by 10	PP multiplied by 20
DSOS	0	0	0
CD	-4.729	-4.666	-4.666
CDOS	-4.729	-4.666	-4.666

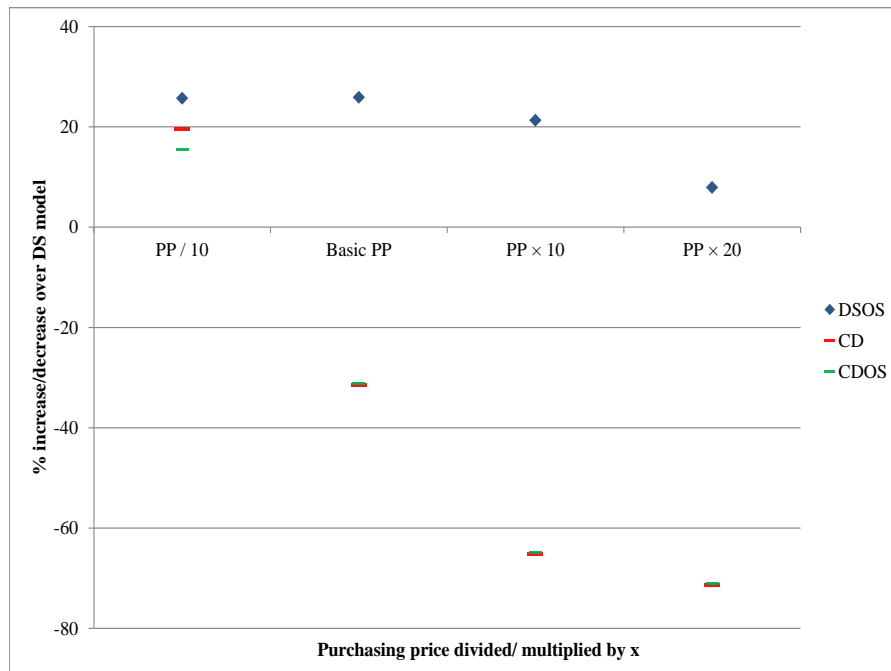

Figure 4.27: % increase/decrease in TC over the DS model for different purchasing prices

4.2.3 Summary of the Results

In previous subsections, we did the numerical analysis for basic models and sensitivity analysis of important parameters. The results show that in all cases (with the selected parameter values) the CD and CDOS models have lower TAC while the DSOS model has higher TAC when compared to the DS model. However, the magnitude of TAC is dependent on the value of the studied parameters. Moreover, in most cases the CDOS model performs better than the CD model. Generally, as the percentage increase/decrease in TAC of the models is dependent on the increase/decrease in the value of the parameters, we cannot absolutely claim whether higher or lower values of these parameters improve or worsen the TAC of the DS, CD, and CDOS models over the DS model.

4 Evaluation and Results of the Four Strategies

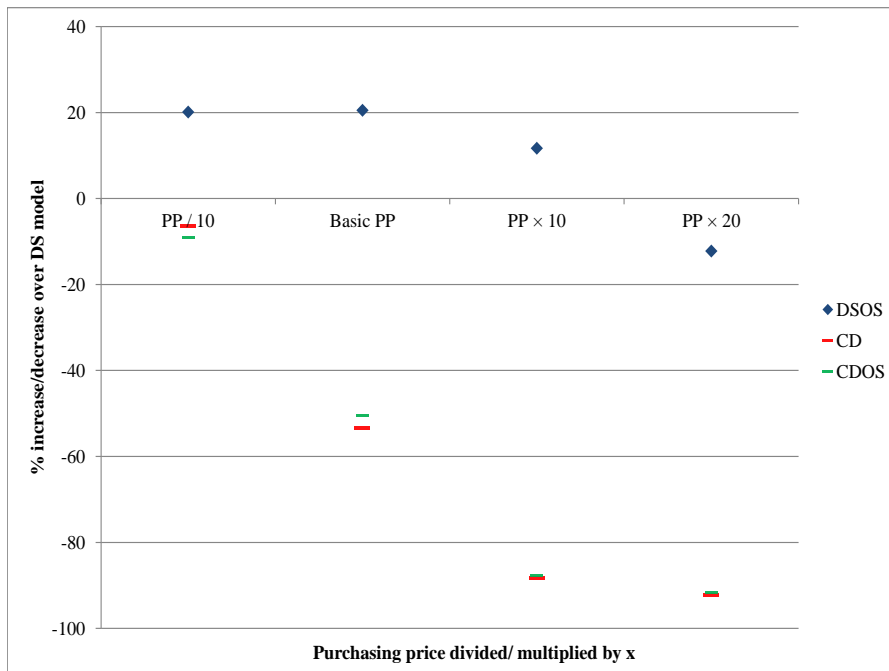

Figure 4.28: % increase-decrease in OC over the DS model for different purchasing prices

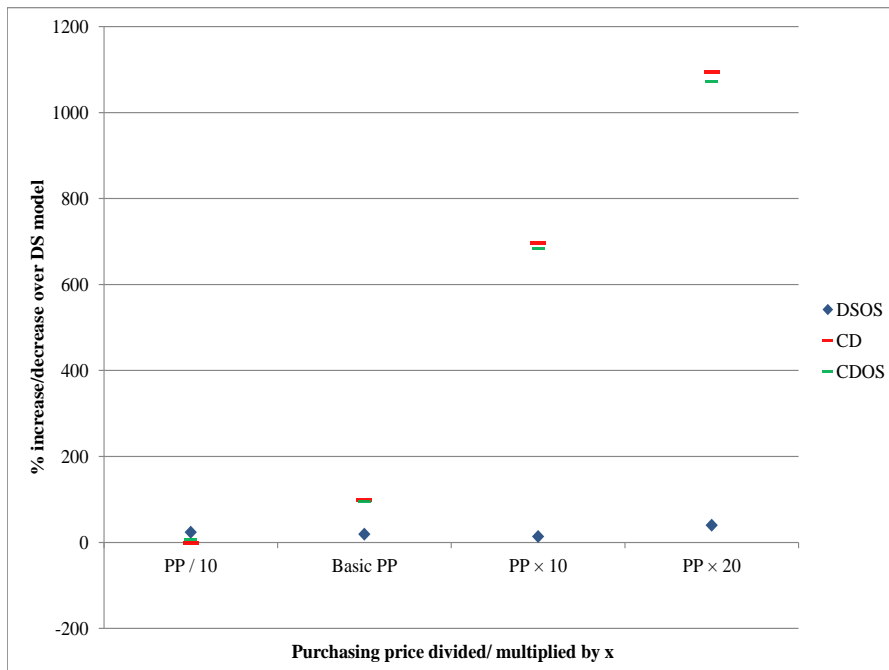

Figure 4.29: % increase/decrease in CSC over the DS model for different purchasing prices

5 Discussion and Summary

5.1 Discussion of the Findings

In chapter 4, we presented the results of the evaluation. We found out that a DSOS has always a higher TAC than a DS model for the given values of the parameters. With this result, we have answered the first research question. We also discovered that among the four developed models, the CDOS model offers the best results with respect to TAC. Next after the CDOS model, the CD model performs the best. Therefore, the answer to the second and third research questions is now provided.

From these results, we can conclude that at the presence of quantity discount offers by the supplier, consolidation of order quantity of individual retailers can have a great impact on total annual cost because it reduces the purchasing price. According to our results, this reduction is noteworthy as the purchasing cost covers the majority of total logistics cost. Thus, even small reductions in purchasing cost can cause great savings. If quantity discounts exist, the CDOS and CD strategies seem to perform much better when compared with the DS and DSOS strategies. This is in line with the work of Munson and Hu (2010) who concluded that centralization of purchasing leads to larger purchase quantities and while the retailers hold inventory, they can still benefit from a discounted purchase price. Although we did not run sensitivity analysis for different quantity discount structures, it is trivial that the magnitude of this benefit is dependent on this structure.

The consolidation also impacts the total transportation cost. This is because the shipments benefits from lower unit transportation cost when the order quantity is larger. On the other hand, if the order quantity of multiple retailers is aggregated and placed by the DC, the whole system bears only one order placement cost.

In contrast to the DSOS model, the advantages of the CD and CDOS models over the DS model are more sensible if the average demand is lower. This

5 Discussion and Summary

means that higher demand rates diminish the advantages of consolidation. Furthermore, when the number of retailers is higher, the CDOS and CD models perform much better over the DS and DSOS models. Again, this indicates the impact of consolidating the order quantity of more retailers on purchasing cost. However, there is a limit to this improvement.

The CDOS model is also more beneficial than the DS model if the order quantity is more evenly split. In addition, the CD and CDOS models perform better when lead time mean is higher. However, increase in coefficient of variation only improves the performance of the CDOS model over the DS model and shrinks the advantages of the CD model. This finding supports the argument that order splitting is a strategy which pools the uncertainty in lead time (Oeser, 2010). Finally, higher purchasing prices do not necessarily result in better performance of the CD and CDOS models. It is important to know that the changes in TAC, when we do a sensitivity analysis of average purchasing prices, are not due to purchasing cost. According to our results, purchasing price does not directly impact the relative value of TAC of the DSOS, CD and CDOS models over the DS model. In fact, purchasing price should be viewed from the aspect that how it influences transportation, ordering and inventory costs. Therefore, one should consider the trade-off between transportation and ordering costs, on the one hand, and cycle stock cost, on the other hand.

As the results of our basic models indicate, even without including the purchasing cost, the CDOS would be the preferred strategy over the CD if the order quantity of both systems is the same. This is proved in our basic models where order quantity equals 466.67 for both models. This indicates that consolidation of individual order quantities weakens the advantages of a non-order splitting system (lower transportation and ordering costs) over an order splitting system while the inventory reduction advantages of the order splitting system still exist. Furthermore, a general understanding of the results demonstrates that almost in all cases considered in our research work, the CDOS model slightly performs better than the CD model (even though they have different order quantities).

We also found out that in those cases where the order quantity of the CDOS and CD models are not equal, the CDOS model has a larger order quantity. On the other hand, the reorder point of the CDOS model is always smaller than the CD model. There is, however, exception where the split proportion is %10-%90. This is not surprising since the delivery proportion of the first

shipment is so small and requires higher reorder point to prevent shortages.

The results further illustrate that even if the suppliers offer quantity discounts, the DS is preferred over the DSOS system. The DSOS has larger order quantity than the DS system. This is in accordance with the findings of previous research works. Therefore, the general inference is that by splitting the order quantity (when it is supplied by a single seller), it is more likely that buyers obtain quantity discounts (Chiang and Chiang, 1996). However, in our work, quantity discounts play no role in direct shipping models because the order quantity of both systems stands between the same price breakpoint. Only if the intervals are sufficiently small, it is probable that offering a quantity discount influences the total cost of order splitting. As shown in results, this is the higher transportation cost of the DSOS model which greatly influences the total cost.

Our findings also indicate that the total annual cost of the DSOS model over the DS model decreases for higher average daily demand and coefficient of variation of lead time. Previous research works also confirm that order splitting is worthwhile when coefficient of variation is high (Chiang and Benton, 1994; Thomas and Tyworth, 2007) and demand rates are relatively high (Thomas and Tyworth, 2007). We also proved that the shipment of a higher proportion of order quantity by the second delivery improves the total cost of the DSOS model. The results of the research work by Meena and Sarmah (2013) confirm our results. They conclude that the minimum total cost is achieved when the split proportion is %10 and %90 for the first and second portion, respectively. Moreover, Sajadieh and Eshghi (2009) also conclude that order quantity should not necessarily be split equally. This is, however, in contrast to the optimal solution of our fourth model (CDOS model) where the split proportion is %50-%50.

Another finding is that longer lead time improves the DSOS model over the DS model. Therefore, the longer the lead time the better the performance of the DSOS model. This is contrary to the results of Ramasesh et al. (1991) who discuss that order splitting performs better when the mean and variability in the lead times (assumed to be exponential) are lower. Lastly, it is trivial that an increase or decrease in the number of retailers has no impact on total annual cost of the DSOS and DS systems.

The fact that order quantity is larger in the DSOS model than in the DS model while reorder point is smaller support the findings of Chiang and Benton

(1994), Chiang and Chiang (1996), and Tyworth and Ruiz-Torres (2000). The lower reorder point means that order splitting provides a better service level than non-order splitting model.

5.2 Summary

A main concern of many supply chain managers is to implement strategies which practically result in reduced inventory cost. This is because space is an expensive asset in many regions. This encourages academics and practitioners to work on strategies that may decrease the cost of inventory. However, appropriate attention should be paid to all main logistic costs so that a decrease in one cost does not cause an increase in other costs. In fact, a supply chain can greatly reduce total annual cost even if either of inventory or transportation cost is not optimal. Therefore, managers can also focus on strategies which reduce purchasing cost.

In the literature, there are plenty of works which have discussed that order splitting reduces inventory carrying costs. However, there are examples that prove the disadvantages of order splitting over non-order splitting model in case realistic transportation cost functions are selected and used. This point was first argued by Thomas and Tyworth (2006) who discussed that, at the presence of realistic transportation cost functions, order splitting is advantageous in specific situations. Unfortunately, this important point is still ignored in many later research works.

In this work, we reviewed the literature on order splitting to see which logistic cost elements are included in the literature. We divided the research stream in two periods, the research works by 2006 (till the work of Thomas and Tyworth in 2006), and after 2006. We concluded that there is no research work that has appropriately included all main logistic cost elements when modeling order splitting problem (Chapter 2).

Then, we developed models to compare the total logistic cost of an order splitting system (DSOS model) with the traditional logistic system (DS model). We involved all the main logistic cost elements including purchasing, transportation, ordering, cycle stock, safety stock, and in-transit stock costs in our model. Therefore, we can claim that we have extended the work of previous researchers. Furthermore, Thomas and Tyworth (2007) proposed a research gap where a single supplier receives an order and delivers it in two

or more shipments sequentially to take advantage of actual information about future delivery and reduce the variability of the demand. We also filled this gap in the literature.

Additionally, we developed an approach and proposed a case where order splitting can perform better than a non-order splitting system. This was done by assuming a multi-echelon system consisting of a supplier, a distribution center (DC), and multiple retailers, where the order quantity of individual retailers is consolidated by the DC and delivered by the supplier to the DC in two separate shipments (CDOS). We also compared this Consolidated Distribution Order Splitting (CDOS) model with a Consolidated Distribution (CD) model but without order splitting (Chapter 3).

To test our proposed models, we ran numerical analysis using “*Mathematica version 10.0*”. The KPI “percentage increase/decrease over the DS model” was used to achieve integrity in making comparisons between the results. Therefore, the evaluation of the DSOS, CD, and CDOS models is performed with respect to the DS model. In line with the work of Thomas and Tyworth (2007), the results of our basic models indicate that the DSOS model has a worse performance over the traditional Direct Shipping (DS) model. Moreover, the CDOS model performs much better than the DS and DSOS models and slightly better than the CD model.

We also performed sensitivity analysis for average daily demand, number of retailers, split proportion, lead time mean, coefficient of variation of lead time, and average purchasing price. For the given values of the above-mentioned parameters, we got the following conclusions. Similar to the results of the basic models, the general conclusion of sensitivity analysis is that the DSOS model always performs worse than the DS model. On the other hand, the CD and CDOS models always perform much better than the DS and DSOS models. The main reason is the great decrease in purchasing cost due to aggregated demand of retailers. In addition, the CDOS performs slightly better than the CD. The other finding is that order quantity of the DSOS model is always higher than order quantity of the DS model. On the other hand, the order quantity of the CDOS model is either equal to (in most cases) or larger than the order quantity of the CD model. We also concluded that order splitting models have a lower reorder point than the related non-order splitting models (Chapter 4). To summarize, the CDOS strategy provides an opportunity to implement an advantageous order splitting system. It actually takes advantage

of demand consolidation.

5.3 Research Limitations and Future Directions for Research

In this work, we assumed that the order is placed on a single supplier. A traditional approach to order splitting is that order quantity is split and placed on multiple suppliers. We believe that at the presence of a quantity discount structure, purchasing cost can be an important element in calculating the cost of an order splitting system. It is very often that suppliers offer quantity discounts to the buyers to motivate them to order larger quantities. Therefore, if a quantity is supplied by two or more suppliers, it is probable that it falls within lower price breakpoints resulting in higher purchasing prices. The inclusion of quantity discount structure is also important in multi-echelon systems where the retailers and DC all are a single entity and the retailers place the orders to the supplier via the DC. Similarly, in a multi-echelon system, if the aggregated orders are split and placed on multiple suppliers, it is probable that it falls in lower price breakpoints. Therefore, as a limitation to our work, we suggest further research when two or more suppliers in multi-echelon systems deliver the order quantity.

In our work, we did not include the changes in incremental ordering cost multiplier A . Even when A is 2 (in our models), we realized that the ordering cost is not that high to significantly influence the total annual cost. However, future research can consider the impact of increase or decrease in A . Another shortcoming of our work is that order quantity is only split in two shipments. Some researchers (Chiang and Chiang, 1996; Abginehchi et al., 2013) have investigated the impact of multiple deliveries on a system total cost. Further works can extend our research to multiple delivery case.

Bibliography

- Abginehchi, S. and Farahani, R. (2010). Modeling and analysis for determining optimal suppliers under stochastic lead times. *Applied Mathematical Modeling*, 34:1311–1328.
- Abginehchi, S., Zanjirani-Farahani, R., and Rezapour, S. (2013). A mathematical model for order splitting in a multiple supplier single-item inventory system. *Journal of Manufacturing Systems*, 32:55–67.
- Biçer, I. (2015). Dual sourcing under heavy-tailed demand: an extreme value theory approach. *International Journal of Production Research*, 53:4979–4992.
- Boone, C., Craighead, C., and Hanna, J. (2007). postponement: an evolving supply chain concept. *International Journal of Physical Distribution & Logistics Management*, 37:594–611.
- Burgin, T. (1972). Inventory control with normal demand and gamma lead times. *Operational Research Quarterly*, 23:73–80.
- Burke, G., Carrillo, J., and Vakharia, A. (2007). Single versus multiple supplier sourcing strategies. *European Journal of Operational Research*, 182:95–112.
- Burke, G., Carrillo, J., and Vakharia, A. (2008). Heuristics for sourcing from multiple suppliers with alternative quantity discounts. *European Journal of Operational Research*, 186:317–329.
- Cachon, G. and Terwiesch, C. (2009). *Matching supply with demand: An introduction to operations management*. New York: McGraw-Hill/Irwin.
- Cai, X. and Du, D. (2009). On the effects of risk pooling in supply chain management: Review and extensions. *Acta Mathematicae Applicatae Sinica*, 25:709–722.

Bibliography

- Cheng, F. and Ye, F. (2011). A two objective optimisation model for order splitting among parallel suppliers. *International Journal of Production Research*, 49:2759–2769.
- Chiang, C. (2010). An order expediting policy for continuous review systems with manufacturing lead-time. *European Journal of Operational Research*, 203:526–531.
- Chiang, C. and Benton, W. (1994). Sole sourcing versus dual sourcing under stochastic demands and lead times. *Naval Research Logistics*, 41:609–624.
- Chiang, C. and Chiang, W. (1996). Reducing inventory costs by order splitting in the sole sourcing environment. *Journal of the Operational Research Society*, 47:446–456.
- Dullaert, W., Maes, B., Vernimmen, B., and Witlox, F. (2005). An evolutionary algorithm for order splitting with multiple transport alternatives. *Expert Systems with Applications*, 28:201–208.
- Elderton, W. and Johnson, N. (1969). *Systems of frequency curves*. London: Cambridge University Press.
- Eppen, G. and Schrage, L. (1981). Centralized ordering policies in a multi-warehouse system with lead times and random demand. *TIMS Studies in the Management Sciences*, 16:51–67.
- Erkip, N., Warren, H., and Nahmias, S. (1990). Optimal centralized ordering policies in multi-echelon inventory systems with correlated demands. *Management Science*, 36:381–392.
- Ganeshan, R. (1999). Managing supply chain inventories: A multiple retailer, one warehouse, multiple supplier model. *International Journal Production Economics*, 59:341–354.
- Ganeshan, R., Tyworth, J., and Guo, Y. (1999). Dual sourced supply chains: the discount supplier option. *Transportation Research Part E*, 35:11–23.
- Ghodsypour, S. and O'Brien, C. (2001). The total cost of logistics in supplier selection, under conditions of multiple sourcing, multiple criteria and capacity constraint. *International Journal of Production Economics*, 73:15–27.

- Glock, C. (2011). A multiple-vendor single-buyer integrated inventory model with a variable number of vendors. *Computers and Industrial Engineering*, 60:173–182.
- Glock, C. (2012). Single sourcing versus dual sourcing under conditions of learning. *Computers and Industrial Engineering*, 62:318–328.
- Glock, C. and Ries, J. (2013). Reducing lead time risk through multiple sourcing: the case of stochastic demand and variable lead time. *International Journal of Production Research*, 51:43–56.
- Graman, G. (1999). *An analysis of capacitated packaging postponement*. PhD thesis, College of Business Administration, Cincinnati: University of Cincinnati.
- Graman, G. (2010). A partial-postponement decision cost model. *European Journal of Operational Research*, 201:34–44.
- Gürbüz, M., Moinzadeh, K., and Zhou, Y. (2007). Coordinated replenishment strategies in inventory/distribution systems. *Management Science*, 53:293–307.
- Gupta, O. and Kini, R. (1995). Is price-quantity discount dead in a just-in-time environment? *International Journal of Operations and Production Management*, 15:261–270.
- Hill, R. (1996). Order splitting in continuous review (q, r) inventory models. *European Journal of Operational Research*, 95:53–61.
- Hong, J. and Hayya, J. (1992). Just-in-time purchasing: single or multiple sourcing? *International Journal of Production Economics*, 27:175–181.
- IOMA (2002). *Handbook of logistics and inventory management*. New York: John Wiley & Sons, Inc.
- Janssen, F., de Kok, T., and van der D Schouten, F. (2000). Approximate analysis of the delivery splitting model. *Journal of the Operational Research Society*, 51:1136–1147.
- Kelle, P. and Miller, P. (2001). Stockout risk and order splitting. *International Journal of Production economics*, 71:407–415.

Bibliography

- Lau, H. and Lau, A. (1994). Coordinating two suppliers with offsetting lead time and price performance. *Journal of Operations Management*, 11:327–337.
- Lau, H. and Zhao, L. (1993). Optimal ordering policies with two suppliers when lead times and demands are all stochastic. *European Journal of Operational Research*, 68:120–133.
- Li, H. and Amini, M. (2012). A hybrid optimisation approach to configure a supply chain for new product diffusion: a case study of multiple-sourcing strategy. *International Journal of Production Research*, 50:3152–3171.
- Meena, P. and Sarmah, S. (2013). Multiple sourcing under supplier failure risk and quantity discount: A genetic algorithm approach. *Transportation Research Part E*, 50:84–97.
- Mishra, A. and Tadikamalla, P. (2006). Order splitting in single sourcing with scheduled-release orders. *Journal of the Operational Research Society*, 57:177–189.
- Mohebbi, E. and Posner, M. (1998). Sole versus dual sourcing in a continuous-review inventory system with lost sales. *Computers & industrial engineering*, 34:321–336.
- Mohr, J. and Spekman, R. (1994). Characteristics of partnership success: partnership attributes, communication behavior, and conflict resolution techniques. *Strategic Management Journal*, 15:135–152.
- Monahan, J. (1984). A quantity discount pricing model to increase vendor profits. *Management Science*, 30:720–726.
- Munson, C. and Hu, J. (2010). Incorporating quantity discounts and their inventory impacts into the centralized purchasing decision. *European Journal of Operational Research*, 201:581–592.
- Murphy, R. (1975). Inventory control with gamma demand and gamma lead times. *International Journal of Systems Science*, 6:81–85.
- Oeser, G. (2010). *Methods of risk pooling in business logistics and their application*. PhD thesis, Faculty of Business, Frankfurt: Europa-Universität Viadrina.

- Qi, X. (2007). Order splitting with multiple capacitated suppliers. *European Journal of Operational Research*, 178:421–432.
- Ramasesh, R., Ord, J., Hayya, J., and Pan, A. (1991). Sole versus dual sourcing in stochastic lead-times, q inventory models. *Management Science*, 37:428–443.
- Ryu, S. and Lee, K. (2003). A stochastic inventory model of dual sourced supply chain with lead-time reduction. *International Journal of Production Economics*, 81-82:513–527.
- Sajadieh, M. and Eshghi, K. (2009). Sole versus dual sourcing under order dependent lead times and prices. *Computers and Operations Research*, 36:3272–3280.
- Sajadieh, M. and Thorstenson, A. (2014). Comparing sourcing strategies in two-echelon supply chains. *Computers and Operations Research*, 45:108–115.
- Schwarz, L. (1989). A model for assessing the value of warehouse risk-pooling: Risk pooling over outside-supplier leadtimes. *Management Science*, 35:828–842.
- Sculli, D. and Shum, Y. (1990). Analysis of a continuous review stock-control model with multiple suppliers. *Journal of the Operational Research Society*, 41:873–877.
- Sculli, D. and Wu, S. (1981). Stock control with two suppliers and normal lead times. *The Journal of the Operational Research Society*, 32:1003–1009.
- Sedarage, D., Fujiwara, O., and Luong, H. (1999). Determining optimal order splitting and reorder levels for n-supplier inventory systems. *European Journal of Operational Research*, 116:389–404.
- Silbermayr, L. and Minner, S. (2013). A multiple sourcing inventory model under disruption risk. *International Journal of Production Economics*, 149:37–46.
- Tadikamalla, P. (1978). Application of the weibull distribution in inventory control. *Journal of Operational Research Society*, 29:77–83.

Bibliography

- Thomas, D. and Tyworth, J. (2006). Pooling lead-time risk by order splitting: A critical review. *Transportation Research Part E*, 42:245–257.
- Thomas, D. and Tyworth, J. (2007). Is pooling lead-time risk by splitting orders simultaneously worthwhile? *Journal of Business Logistics*, 28:169–192.
- Torrey, W. and Murray, D. (2015). An analysis of the operational costs of trucking: 2015 update. Technical report, Arlington: American Transportation Research Institute.
- Tsai, W. and Wang, C. (2010). Decision making of sourcing and order allocation with price discounts. *Journal of Manufacturing Systems*, 29:47–54.
- Tyworth, J. and Ruiz-Torres, A. (2000). Transportations role in the sole versus dual-sourcing decisions. *International Journal of Physical Distribution and Logistics Management*, 30:128–136.
- van Hoek, R. (2001). The rediscovery of postponement: A literature review and directions for research. *Journal of Operations Management*, 19:161–184.