

7.4 High Frequency Plasma Enhancement of a Conventional Spark Ignition System to Extend the Operating Range of a Modern Mass-Production Engine

Kevin Stark, Sven Gröger, Marcel van Delden, Gordon Notzon, Wolfgang Eifler, Thomas Musch, Peter Awakowicz

Abstract

Achieving future emission and fuel efficiency standards represents an increasingly challenging aspect in developing modern powertrains. Numerous alternative ignition systems have previously been proposed to replace or enhance the conventional transistor spark ignition concept. Up to now, the robust and simple design of the conventional system, few components and high maximum energy input into combustion chamber continue to justify its use. Rosenberger Hochfrequenztechnik GmbH & Co. KG is working with Ruhr University Bochum on extending this proven ignition concept. To this end, the conventional spark ignition system has been retained and expanded only with a path for coupling a high-power, high frequency (HF) signal. When a spark is conventionally generated, a low impedance conductive channel is formed between the spark plug's electrodes. Since the power input of a conventional ignition coil is limited, the HF signal energy is additionally introduced into this channel thereby creating a controllable and adjustable HF plasma discharge between the electrodes with a much larger plasma volume compared to the original spark. As both the duration and power of the HF plasma discharge can be arbitrarily set, the prerequisite energy for mixture ignition can also be provided beyond previous operating ranges. Experiments on a highly developed mass-production engine (2017 EA 211 Evo model, Volkswagen AG) showed that engine operation could be ensured in various, ignition-critical operating points. A significant fuel consumption advantage was exemplary found in terms of idling. At 1000 min^{-1} , an indicated mean pressure (p_{mi}) of 1 bar, and a corresponding standard deviation less than 0.1 bar, 14 g/kWh could be saved by the extended use of internal exhaust gas recirculation. In addition to engine results, the detailed design of the ignition system and measurement technology required for system analysis are also presented.

Kurzfassung

Das Erreichen künftiger Abgas- und Verbrauchsrichtlinien stellt bei der Entwicklung moderner Antriebsstränge eine zunehmend große Herausforderung dar. In der Vergangenheit wurde eine Vielzahl alternativer Zündsysteme vorgestellt, welche die konventionelle Transistor-Funkenzündung ersetzen oder erweitern sollten. Der robuste und einfache Aufbau, die geringe Anzahl an Bauteilen und der hohe maximale Energieeintrag in den Brennraum rechtfertigen dessen Einsatz jedoch bis heute. Die Firma

Rosenberger Hochfrequenztechnik GmbH & Co. KG arbeitet zusammen mit der Ruhr-Universität Bochum an einer Erweiterung dieses bewährten Zündkonzepts. Das konventionelle Funkenzündsystem wird hierfür beibehalten und lediglich um einen Pfad zur Einkopplung eines hochenergetischen, hochfrequenten (HF) Signals erweitert. Während des konventionell erzeugten Funkens entsteht zwischen den Elektroden der Zündkerze ein leitfähiger Kanal mit niedriger Impedanz. Da die Leistung der konventionellen Zündspule begrenzt ist, wird zusätzlich in diesen Kanal die Energie des HF-Signals eingebracht. Dadurch entsteht eine steuerbare HF-Plasmaentladung zwischen den Elektroden mit einem deutlich größeren Plasmavolumen verglichen mit dem Funken. Sowohl die Dauer als auch die Leistung der HF-Plasmaentladung können beliebig eingestellt werden. Dadurch kann auch außerhalb der bisherigen Betriebsbereiche die für die Entflammung des Gemischs notwendige Energie bereitgestellt werden. Versuche an einem hochentwickelten Großserien-Motor (2017 EA 211 Evo model, Volkswagen AG) zeigten, dass so der Motorlauf in verschiedenen, zündkritischen Betriebspunkten sichergestellt werden konnte. Im Bereich des Leerlaufs konnte beispielsweise ein signifikanter Verbrauchsvorteil festgestellt werden. Bei einer Drehzahl von 1000 min^{-1} , einem indizierten Mitteldruck (p_{mi}) von 1 bar und einer zugehörigen Standardabweichung kleiner als 0.1 bar konnten 14 g/kWh durch den erweiterten Einsatz von interner Abgasrückführung eingespart werden. Neben den motorischen Ergebnissen wird der detaillierte Aufbau des Zündsystems sowie die für eine Analyse des Systems notwendige Messtechnik vorgestellt.

1 Introduction

Exploiting the remaining optimization potential of current gasoline engines represents an increasingly major challenge for the industry. One such potential involves improving the combustion process. Studying the cylinder pressure curve of several combustion cycles over time shows that no combustion equals previous ones. While these cycle-to-cycle variations mainly influence driving comfort, they also impact the raw emissions of an internal combustion engine. Furthermore, increasing deviation could lead to an increase in fuel consumption, since a percentage of the optimal centre of heat release is deviated. A prerequisite for the development of modern internal combustion engines is therefore to optimally minimize these cycle fluctuations. Yet simultaneously, the aim is to continuously improve the combustion process's thermodynamic efficiency. Approaches such as the Miller combustion process, the use of high residual gas rates, as well as lean concepts serve to complicate flame propagation and consequently produce irregularity of combustion cycles [1].

The ignition of the mixture forms the basis of gasoline engine combustion. After local inflammation in the area of the spark plug, the flame front spreads independently through the combustion chamber. Modern ignition systems, which work according to the principle of transistor coil ignition, ensure safe ignition across wide operating ranges. Hence due to its relative simplicity, this ignition concept can be found in most automobiles since its invention. However, the constantly more stringent legislation governing consumption and exhaust gas is pushing this concept to its limits. In the following section, the basic structure of a conventional ignition system is described in order to comprehend those limits [2].

1.1 Fundamentals of ignition technology

The conventional transistor ignition system essentially comprises a spark plug, ignition coil, ignition output stage, as well as connection and suppression parts. Former multi-cylinder engines are operated by one ignition coil and an ignition voltage distributor, which connects the ignition coil to the respective spark plug. Modern gasoline engines are equipped with a single-spark ignition coil and an integrated output stage. Each spark plug mounted in the cylinder head is directly connected with this single-spark ignition coil. A minimal connection length between the ignition coil and the spark plug reduces electromagnetic radiation.

Single-spark ignition coils with integrated output stage fundamentally comprise two transformer-coupled coils. If the output stage is switched on by the engine control unit, current flows through the primary coil. The interruption of the primary current leads to the collapse of the magnetic field. Due to this rapid magnetic field change and high winding number of the secondary coil (ratio of about 1: 100 [3]), a high voltage of several 10 kV is induced. The energy stored in the ignition coil can be influenced by varying the timespan between switching on and interrupting the primary current.

Due to the direct contact of the secondary coil and the centre electrode of the spark plug, the parasitic capacitance of the spark plug is charged first. If the breakdown voltage is reached, the parasitic capacitance discharges in a spark plasma between the electrodes of the spark plug. In this phase, the spark plasma is a thin plasma channel with high electron density and high gas temperature that connect the electrodes. A plasma consists (amongst others) of electrons, ions and neutral gas particles. Due to the free charged particles (electrons and ions), the plasma channel is electrically conductive. In the second phase, the residual energy stored in the ignition coil discharges in the plasma channel, resulting in more diffused plasma with lower electron density. The burning voltage in this phase is a few hundred volts, depending on electrode gaps and turbulence in the combustion chamber.

At the ignition timing, (switching off the ignition coil) an ignitable air-fuel mixture must be located at the spark plug electrodes. For stoichiometric and homogeneous fuel-air mixtures ($\lambda = 1$) this condition is fulfilled. Resting, homogeneous and stoichiometric air-fuel mixtures need minimum ignition energy for combustion. To save natural resources, engine operating points that deviate from the stoichiometrically homogeneous mode are increasingly interesting. The energy requirement increases for the ignition of lean air-fuel mixtures ($\lambda > 1$) or with the higher addition of exhaust gas. Investigations in [4] clearly show that high flow velocity, high turbulence intensity, and non-stoichiometric engine operation ($\lambda \neq 1$) lead to increased minimum ignition energy.

Therefore, the development of alternative ignition systems helps to expand the operating range of gasoline engines and can increase their efficiency. In the past, the economic benefit often did not justify the technical effort. The mass production of alternative ignition systems in the automotive sector has so far been limited by the high additional costs compared to conventional robust ignition technology [4].

1.2 High frequency plasma enhanced spark ignition

Spark ignition, based on a single spark ignition coil and spark plug, is proven, robust and inexpensive ignition technology for the automotive sector. A certain operating win-

dow is specified by the use of conventional ignition systems. If environmental regulations or modified fuels force the expansion of this operating window, conventional spark ignition can be enhanced with high frequency (HF) plasma.

As previously mentioned, the spark forms a conductive plasma channel between the spark plug's electrodes. If an HF alternating voltage is simultaneously applied to the centre electrode of the spark plug, an HF alternating current can flow and subsequently an HF plasma discharge is formed between the electrodes. As a first big advantage, the HF plasma discharge is adjustable in duration and power. Typical burning durations are in the range of milliseconds with an active plasma power up to 150 W. The frequency of the applied HF voltage operates in the megahertz range, and generates a diffuse and large-volume plasma compared to conventional spark discharge (see Figure 5). An adjustment of the combustion chamber or spark plug is not required for the operation of the spark ignition system enhanced by HF plasma. In order to avoid power losses, the spark plug itself must be free of any internal resistance.

HF plasma enhanced spark ignition offers the advantage that the gasoline engine can still be operated with conventional spark ignition in its previous operating window. In addition, HF plasma can be added to extend the conventional operating window adjusted to the individual ignition situation, depending on exhaust recirculation, stoichiometry and others. The HF enhancement can therefore be switched on depending on the operating status, and can also be adjusted in terms of burning duration and power.

2 System Realization

2.1 Ignition System

To ensure efficient and cost-effective implementation, the new ignition system is based on a sophisticated combination of conventional components and new HF power components, as shown in Figure 1. On the one hand, the utilized conventional ignition coil (VW part number 05E 905 110) generates a high voltage pulse up to 45 kV. This is connected to the centre electrode of the conventional, resistor-free spark plug and generates the initial spark. On the other hand, an HF power amplifier generates a high frequency alternating signal. This is also connected to the centre electrode of the spark plug via a coupling network, and provides the energy for the HF plasma discharge.

7.4 High Frequency Plasma Enhancement of a Conventional Spark Ignition System to Extend the Operating Range of a Modern Mass-Production Engine

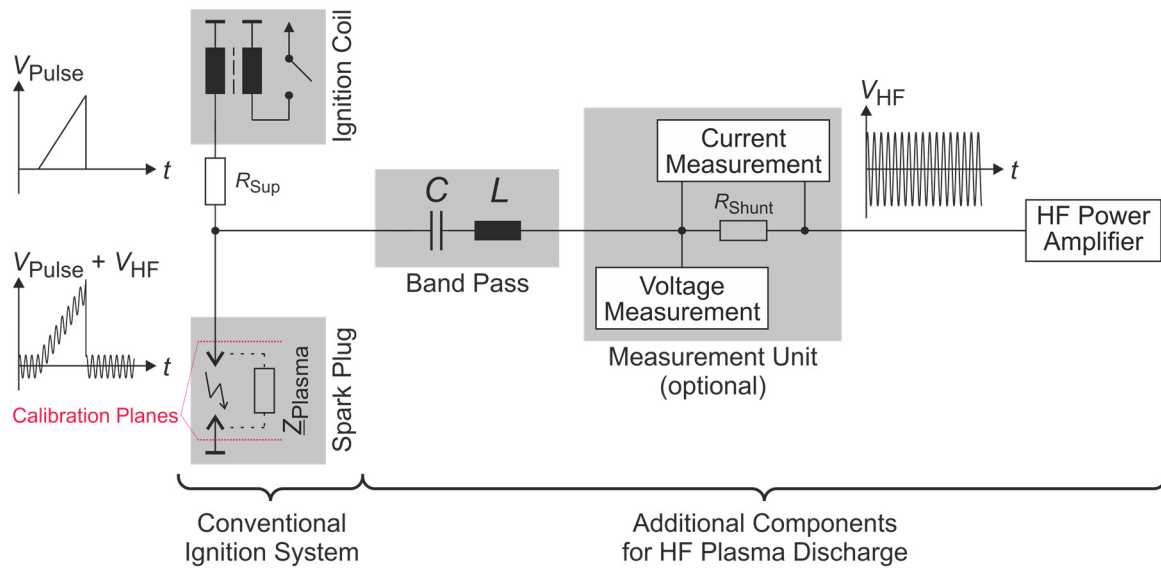

Figure 1: Block diagram of the new ignition system including optional electrical measurement unit.

The amplifier depicted in Figure 2 accords to the Class E principle and is based on a prototype in [5]. It is operated at a frequency of $f_0 = 10$ MHz and generates an active RMS power of 500 W at a load impedance of 50Ω . The electrical impedance of the conductive HF plasma discharge Z_{Plasma} varies over a wide range due to various conditions at the ignition timing in the combustion chamber. Examples include pressure, turbulence, temperature, and composition of the air-fuel mixture. Therefore, a matching network is integrated into the amplifier. This is optimized to provide a constant high output power over the wide range of load impedances typical for the new ignition system. Thus, for a resistance (real part of the impedance) in the range of $120 \Omega < R_{\text{Plasma}} < 500 \Omega$, the output power only varies by about 20%. Furthermore, the power can be adjusted via the supply voltage.

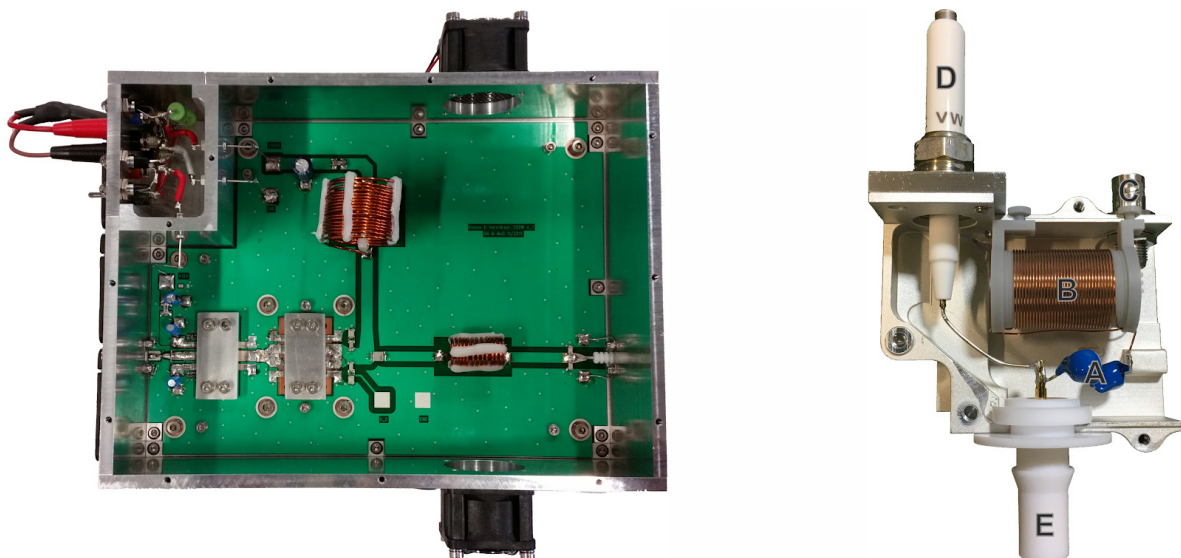

Figure 2: Photograph of the amplifier (left) and combiner box (right) with high voltage capacitors (A), air coil (B), MHV plug (C), auxiliary spark plug (D) and plug for internal resistance-free spark plug (E). Property of Rosenberger Hochfrequenztechnik GmbH & Co. KG.

The coupling network is used to decouple the high voltage pulse from the amplifier, and to couple the high frequency signal to the centre electrode. It therefore comprises an LC resonant circuit, which represents a band pass filter with the resonance frequency $f_0 = 10$ MHz. A cascade of two high voltage capacitors is used to block the high voltage pulse of the ignition coil, which are connected to the end of the spark plug's centre electrode. The capacitance C , and thus the load of the ignition coil, should be respectively low. Otherwise, the peak voltage of the high voltage pulse will decrease. The inductance L is connected to the capacitance on one side and to the MHV plug on the other. The latter is used to connect the optional measurement unit and the HF power amplifier. The inductance L should be respectively low as well to minimize power losses and critical thermal stress of the ignition system. The inductance is therefore realized as an air coil, because it does not exhibit any hysteresis losses. Concerning ideal components, the resonance frequency is

$$f_0 = \frac{1}{2\pi\sqrt{LC}}. \quad (1)$$

A trade-off between the inductance L and the capacitance C must therefore be made. Due to the comparatively low impedance of the HF plasma discharge, conventional spark plugs without internal resistor must be used. Otherwise, the power losses in the internal resistor would be significant and even higher than the power provided to the HF plasma discharge. Furthermore, the electrodes of spark plugs for modern gasoline engines often consist of platinum, iridium or a combination of both (e.g. NGK 05E905602). These precious metals are particularly suitable, as they exhibit good erosion resistance.

In order to integrate the suppression resistor R_{Sup} , which is required for the high voltage pulse, a conventional spark plug with internal resistance (auxiliary spark plug) is utilized for this prototype. Therefore, the bow-shaped ground electrode is removed and the tip of the centre electrode is connected to the end of the centre electrode of the resistor-free spark plug. The end of the auxiliary spark plug acts directly as a plug for the conventional ignition coil.

In order to ensure high electrical strength of the system, the following components are sealed: Coupling network together with MHV plug to connect the measurement unit / amplifier, auxiliary spark plug, and a plug for the resistor-free spark plug. This design, which is integrated in an aluminum housing optimized for installation space, is referred as "combiner box" in the following sections. The unsealed setup is shown in Figure 2. According to [6], a single amplifier is sufficient for operation on a multi-cylinder engine. Each individual cylinder requires only a dedicated combiner box equipped with an ignition coil. Thus, the additional hardware effort and consequently additional costs of the new ignition system are low compared to conventional ignition systems. The resulting entire ignition system for the four-cylinder series engine used is depicted in Figure 3.

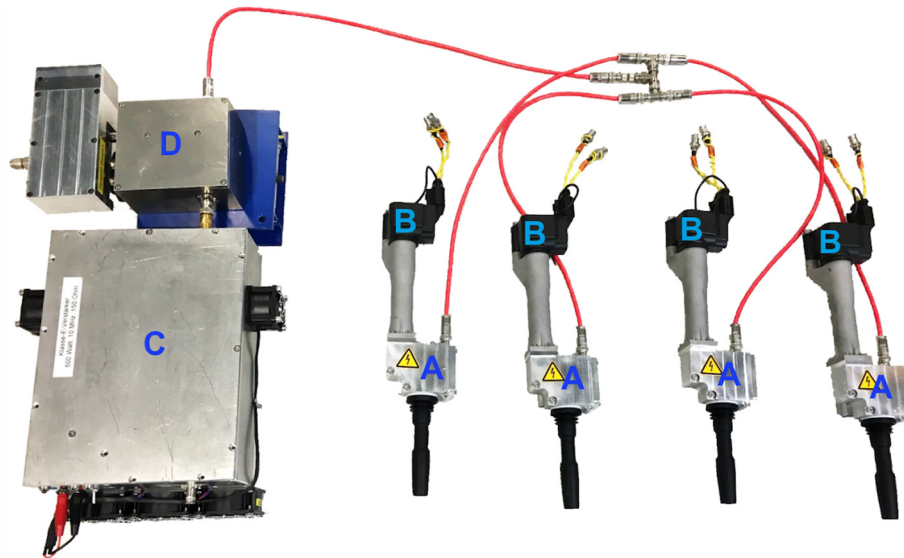

Figure 3: Photograph of the entire ignition system for a four-cylinder engine with four combiner boxes (A) and ignition coils (B), high frequency power amplifier (C), as well as electrical measurement unit (D). Property of Rosenberger Hochfrequenztechnik GmbH & Co. KG.

2.2 Electrical Measurement System

A measuring technique was developed to determine complex plasma impedance $\underline{Z}_{\text{Plasma}}$ and active plasma power P_{Plasma} over time. Based on measurement results, the output impedance of the HF power amplifier is matched to the complex plasma impedance $\underline{Z}_{\text{Plasma}}$ to maximize power transfer. Furthermore, active plasma power P_{Plasma} can be monitored and regulated.

For this purpose, a developed measurement unit is integrated between the band pass filter and the HF amplifier using MHV connectors, in order to minimize requirements for electric strength, see Figure 1. Two measuring points are located inside the measurement unit. The voltage measurement is realized using a capacitive voltage divider. The current measurement outputs a voltage proportional to the current through the shunt-resistor R_{Shunt} . Hence, two linearly independent measurements are available, which allow for system calibration. According to [7], a system error correction can be performed using a four-port to two-port reduction, and three easy-to-implement calibration standards Open, Short, and Match (OSM). The HF plasma discharge is heated between the spark plug's electrodes. In order to determine the electrical plasma parameters as accurately as possible, the calibration planes were chosen appropriately as illustrated in Figure 1. Accordingly, the calibration standards are placed between the electrodes. Regarding the Open calibration standard, no changes have been made to the spark plug. The Short calibration standard consists of a brass element to short the spark plug's electrodes. As the Match calibration standard, a 150Ω HF resistor is used, which is in the range of the active plasma resistance R_{Plasma} . The resistor is placed between the electrodes by means of a low-capacitance and low-inductance clamping fixture. This eliminates the need for a soldering process, which would damage the electrodes.

Since the individual system components are built up reproducibly, the calibration procedure needs to be performed only once and can then be transferred to other ignition systems.

By using OSM calibration, the complex plasma impedance

$$\underline{Z}_{\text{Plasma}} = R_{\text{Plasma}} + jX_{\text{Plasma}}, \quad (2)$$

consisting of resistance R_{Plasma} and reactance X_{Plasma} , is determined. Additionally, during the calibration process a voltage measurement at the Match calibration standard is performed once using a voltage probe. Thus, the complex plasma power

$$\underline{S}_{\text{Plasma}} = P_{\text{Plasma}} + jQ_{\text{Plasma}} = \underline{V}_{\text{Plasma}} \cdot \underline{I}_{\text{Plasma}}^*, \quad (3)$$

consisting of active power P_{Plasma} and reactive power Q_{Plasma} , is also determined. The complex voltage $\underline{V}_{\text{Plasma}}$ and the complex current $\underline{I}_{\text{Plasma}}$ are therefore also given by Ohm's law.

Using a Tektronix MSO4034 Digital Storage Oscilloscope (DSO), the output signals of the measurement unit and voltage probe are digitized with 250 MSa/s. The calibration process and evaluation of the measurements are performed automatically inside a developed software environment.

Generally speaking, a plasma is represented by a nonlinear, time-variant impedance. Therefore, the measured signals contain frequency components in multiples of the excitation frequency $f_0 = 10$ MHz. The high sampling frequency ensures that the sampling theorem is fulfilled. A second-order Goertzel algorithm is used to ensure fast and efficient signal evaluation at excitation frequency f_0 , performed in steps of 10 μs to achieve a 10 μs time resolution of electrical plasma parameters. The resulting 10 μs window length leads to a sufficiently high frequency resolution of 100 kHz.

For the following investigations, the spark plug was mounted into a pressure vessel with optical windows. The measurements were performed inside synthetic air (21% O_2 , 79% N_2) with 5 bar pressure, without air flow, and without turbulence. Figure 4 illustrates the measurement results of the electrical plasma parameters over time.

The falling edge of the ignition coil control signal is used here to trigger the DSO ($t = 0$ s). The HF source is turned on 200 μs before spark ignition, and is turned off 1 ms after spark ignition. Both limits can be set variably. Outside the chosen limits, the measurement results are noisy due to the absence of signal energy. In the 200 μs range before spark ignition ($t < 0$ s) there is no active plasma power P_{Plasma} , because no conductive channel between the electrodes exists ($R_{\text{Plasma}} \gg$). Furthermore, the measured RMS open-circuit voltage between the electrodes is $|\underline{V}_{\text{Plasma}}| \approx 540$ V. Right after spark ignition ($t > 0$ s), the active resistance decreases to $R_{\text{Plasma}} \approx 120 \dots 160 \Omega$, the RMS voltage decreases to $|\underline{V}_{\text{Plasma}}| \approx 110$ V, the RMS current increases to $|\underline{I}_{\text{Plasma}}| \approx 750$ mA, and the RMS active power increases to $P_{\text{Plasma}} \approx 70 \dots 80$ W.

In order to correlate the electrical measurements with optical investigations, time-synchronous measurements were performed. A very fast four-fold camera system (HFSC pro, produced by PCO) was used, comprising four single ICCD (intensified charge-coupled device) cameras with common optical input via beam-splitter optics. The four cameras can be controlled independently of each other. To observe the HF plasma discharge with burning duration of 1 ms time-resolved, the exposure time of each camera was selected to $t_{\text{exp}} = 250 \mu\text{s}$. Camera 1 is triggered when the ignition coil is switched off ($t = 0$ s, see Figure 4). Camera 2 is triggered after the end of the exposure time of camera 1, and cameras 3 and 4 according to cameras 2 and 3 respectively. This results in a sequence of four consecutive images with total exposure time of 1 ms. The image intensifiers of individual cameras were selected so that the intensity of the

four images is comparable. Figure 5 shows the time sequence of pure spark discharge (images A, B, C, D) and HF plasma enhanced spark discharge (images E, F, G, H). The spark discharge in Figure 5 A displays an intensively glowing spark channel between the spark plug's electrodes. The following pictures B, C and D depict the burnout of the spark with lower intensity. Figure 5 E shows the initial spark and HF plasma discharge. Due to the immediate takeover of the HF plasma discharge, a clear distinction between spark and HF plasma discharge cannot be established in this image. The comparison of Figures B, C, D with F, G, H clarifies that the HF plasma has a much larger volume and higher intensity. Both attributes have positive effects on ignition.

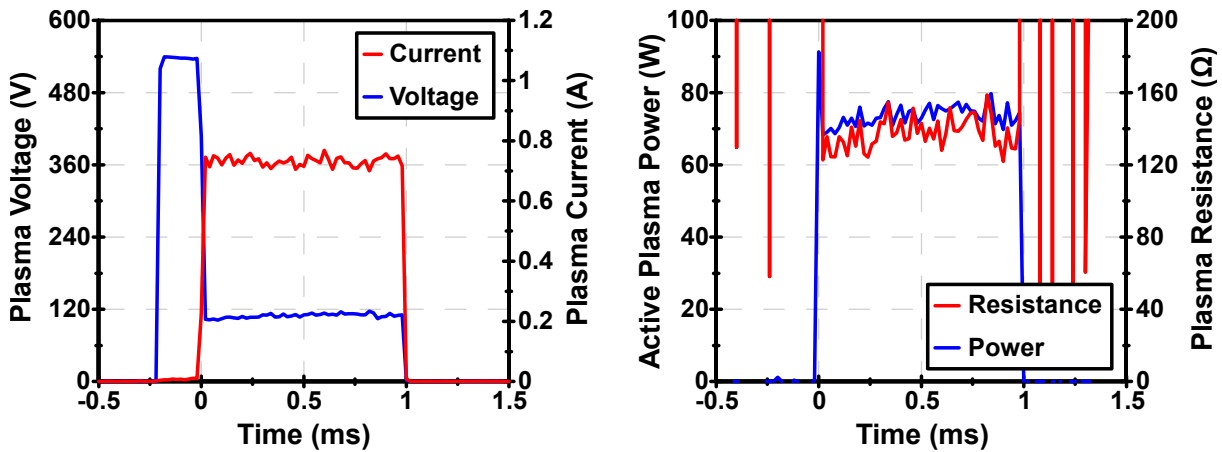

Figure 4: Time-resolved measurement of current and voltage (left) as well as active plasma power and active resistance (right) of HF plasma at 5 bar air in a pressure vessel.

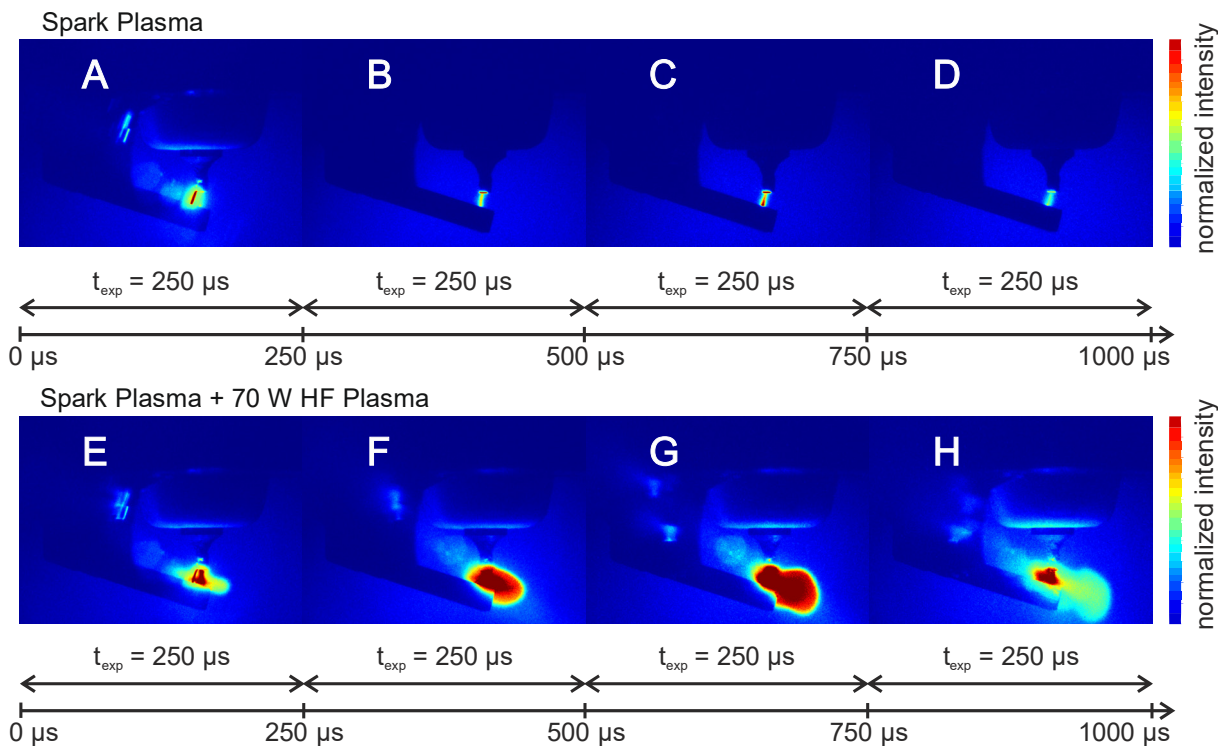

Figure 5: Time-resolved photography of spark plasma (top) and HF support plasma discharge (bottom) in a pressure vessel at 5 bar pressure in synthetic air.

3 Experimental Setup

A modern four-cylinder engine (2017 EA 211 Evo model, Volkswagen AG) was used to measure the following results. The high development level of the TSI engine provides a good basis for a valid and future-orientated estimate of the ignition system's potential. The gasoline engine is equipped with a Generation 4.0 direct injection system and an exhaust gas turbocharger with variable turbine geometry. A stroke/bore ratio of 1.15 results from 85.9 mm stroke and 74.5 mm bore diameter. The compression ratio is 12.5:1. Depending on the operating point, two cylinders can be deactivated by disabling the valve train. The Miller cycle (early closing of inlet valves) can be used by varying the timing of the inlet camshaft by up to 70° CA. The adjustment range of the exhaust camshaft (40° CA) allows variation of the internal recirculated exhaust gas rate, and reduction of the charge exchange losses. The combustion chamber masking, its geometric design, and high tumble concept of the inlet port increase the charge motion in the low RPM range. The nominal power of 96 kW is reached at 1.3 bar boost pressure. Further integrated technologies have a subordinate role in the operating range of an ignition system, and can be found in [8].

Due to its high development level, the test engine exhibits safe ignition conditions in conjunction with the series ignition system across almost all operating ranges. Delayed combustion and misfires can occur due to the exhaustion of secondary measures that increase efficiency. Such secondary measures can include dilution of the charge with high residual gas rates, as well as a considerable increase in air/fuel ratio.

The engine was operated on an engine dynamometer for the tests, which ensured safe operation in ignition-critical areas in addition to ideal monitoring options. The engine's RPM could be kept constant through the bivalent operation of the dynamometer brake (electric motor), even in the case of misfiring. The combustion process could be continuously analyzed during operation by using high and low pressure indication. The intake and exhaust gas systems were comparable to the installation in series vehicles. All tests were conducted with conditioned ambient air and powertrain at operating temperature to improve comparability.

4 Measurement Results and Discussion

The following measurements show a comparison between conventional ignition and ignition enhanced by HF plasma discharge. For the reference measurement, the ignition system presented in section 2.1 was operated without any additional energy from the high frequency amplifier. Comparative measurements have proven that this setup is representative for the series ignition system, since the influence of the band pass on the high voltage pulse is negligible. This setup allows the HF plasma discharge to be switched on and off during operation. The direct influence of additional ignition energy can be rated at constant operating points.

The tests show that the strongest influence of HF plasma discharge typically occurs in the range of critical ignition conditions. Figure 6 illustrates the curve of specific fuel consumption as a function of the camshaft timing "Intake open". An earlier opening of inlet valves increases the area of valve overlap, and thus increases the percentage of residual gas during charge exchange. The higher residual gas ratio increases inhomogeneity in the combustion chamber, and raises the mixture's heat capacity. In order to reduce the charge movement, the speed was set to $n = 1000 \text{ min}^{-1}$ and the load close to idling ($p_{\text{mi}} = 1 \text{ bar}$). Up to a camshaft timing of -5° CA TDC, there is no difference in

fuel consumption between the two systems. At a camshaft timing of -10° CA TDC, operation with conventional ignition was not possible due to delayed combustion and misfiring. In the further course, a significant consumption advantage (14 g/kWh) is evident by the use of the ignition system enhanced by HF plasma discharge. Due to the controllability of the additional energy input, an operating map-dependent precontrol is therefore reasonable. At critical operating points, corresponding additional power can be provided, while the mixture is ignited conventionally by coil discharge in the rest of the operating map.

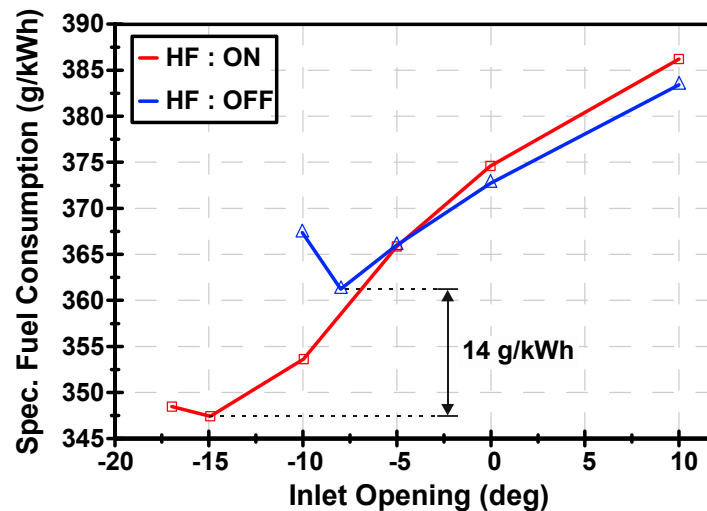

Figure 6: Inlet opening-resolved measurement of specific fuel consumption with (red) and without (blue) HF plasma enhancement at $n = 1000 \text{ min}^{-1}$, $p_{mi} = 1 \text{ bar}$.

An increase in the standard deviation of the indicated mean pressure of all cylinders above 0.1 was assumed as the test's termination condition as illustrated in Figure 7. In the non-ignition critical range (Inlet Opening $> -5^\circ$ CA TDC) there is no difference between the two systems with regard to the engine's smooth operation. Opening the inlet valves -8° CA TDC already leads to a significant increase in the standard deviation with conventional ignition. Switching on the HF plasma discharge eases this operating point, and achieves acceptable running smoothness up to a camshaft timing of -15° CA TDC.

Increased ignition energy due to using HF plasma discharge has a further effect on ignition delay time. Even where the conventional ignition system ensures inflammation, a reduction in ignition delay time is achieved. This effect increases with higher residual gas ratio, as shown in Figure 7.

7.4 High Frequency Plasma Enhancement of a Conventional Spark Ignition System to Extend the Operating Range of a Modern Mass-Production Engine

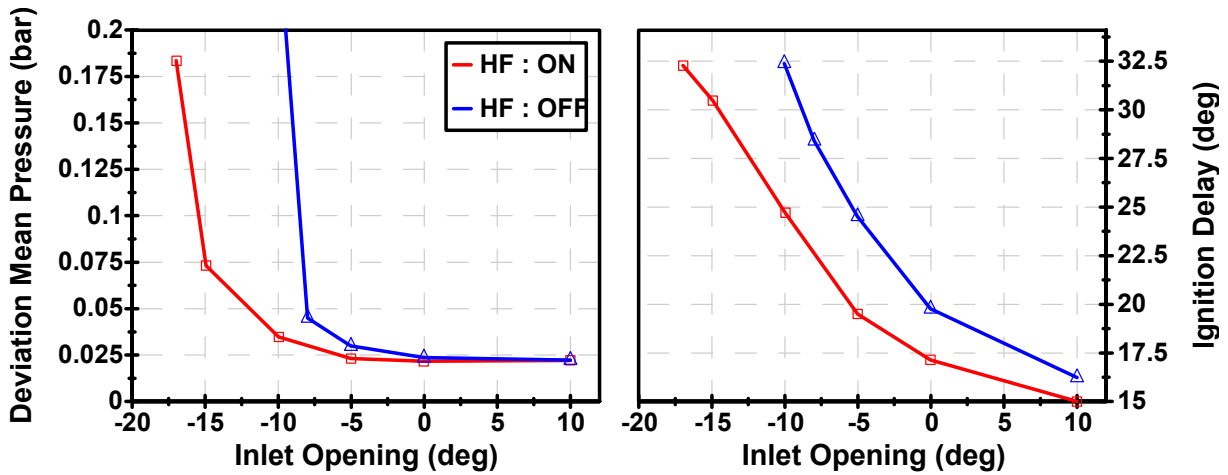

Figure 7: Inlet opening-resolved measurement of the deviation of indicated mean pressure (left) or ignition delay (right) with (red) and without (blue) HF plasma enhancement at $n = 1000 \text{ min}^{-1}$, $p_{mi} = 1 \text{ bar}$.

As described above, charge motion, residual gas rate and inhomogeneity of the mixture significantly influence inflammation capability. In order to reduce influencing factors, a measurement with higher charge motion and better homogeneity is presented below. For this, $n = 2000 \text{ min}^{-1}$ at an indicated mean pressure $p_{mi} = 2 \text{ bar}$ was selected. At this operating point, the critical ignition conditions were created by leaning the mixture, since the residual gas rate cannot be exactly quantified by varying the inlet camshaft timing. Figure 8 illustrates the mean value of the standard deviation of the indicated mean pressure of all cylinders as a function of the variation of air/fuel ratio. Even with reduced influencing factors, a clear advantage compared to conventional spark ignition can be noticed. Reduced ignition delay time can also be observed in Figure 8 (analogous to Figure 7).

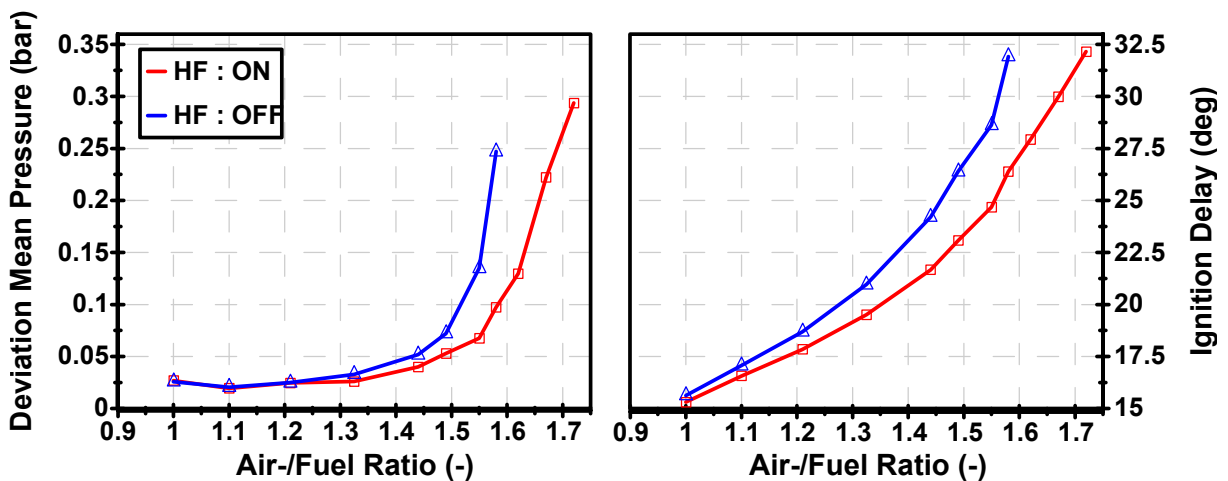

Figure 8: Air-/fuel ratio-resolved measurement of the deviation of indicated mean pressure (left) or ignition delay (right) with (red) and without (blue) HF plasma enhancement at $n = 2000 \text{ min}^{-1}$, $p_{mi} = 2 \text{ bar}$.

The presented results show that the additional energy enhanced through HF plasma discharge stabilizes the combustion in critical ignition areas. It should be noted that all

presented experiments were performed with electrode geometry, spark position and combustion chamber design optimized for the operation of conventional spark ignition and not for HF plasma operation. It is well-known that electrode geometry in particular strongly influences the stability of plasma. Figure 9 shows the power of the HF plasma discharge supplied to the combustion chamber during the experiment. Optimization of the electrode geometry and the resulting stabilization of plasma channel reduces the deviation of this additional energy input, which leads to a further increase in the mentioned advantages of HF plasma ignition.

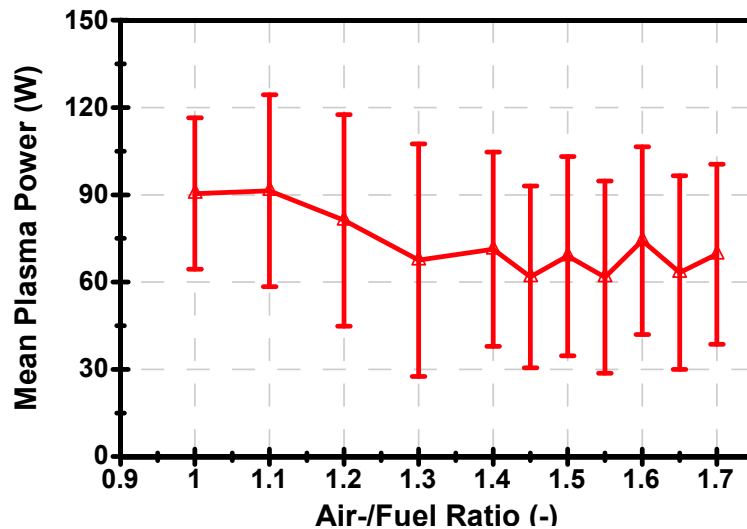

Figure 9: Mean value and measured value interval over 30 readings of time-averaged plasma power P_{Plasma} with 1 ms plasma duration at $n = 2000 \text{ min}^{-1}$, $p_{mi} = 2 \text{ bar}$ and variation of air-/fuel ratio

5 Summary

This article presented the enhancement of a conventional transistor spark ignition system with a high frequency plasma discharge. The simple integration, option of variable control of additional energy input, as well as large number of series components used serve to reinforce the multitude of application possibilities of the system. The tests proved that the operating range of a modern series engine could be extended. It was shown that significant consumption advantages could be achieved through secondary measures in critical ignition areas. At 1000 min^{-1} , a load close to idle, and a standard deviation of the indicated mean pressure less than 0.1 bar, the specific fuel consumption could be reduced by 14 g/kWh. The volume of HF plasma is clearly larger and the ignition delay is reduced compared to conventional sparks, while the burning duration is not significantly decreased.

The aim, to use as many series components as possible to demonstrate a significant influence of ignition enhancement by using HF plasma discharge, has been successfully fulfilled. Nevertheless, minor adjustments to electrode geometry and materials are advisable in order to exploit the system's full potential. The system concept allows an operating map-dependent precontrol. For particularly difficult ignition conditions an additional real-time control of the supplied HF plasma energy is conceivable.

Acknowledgements. The research and development of the HF plasma enhanced ignition system is funded by Rosenberger Hochfrequenztechnik GmbH & Co. KG. The authors would especially like to thank Martin Fuchs, Gunnar Armbrecht, Michael Wollitzer, and Gregor Reiner.

References

- [1] Internal Combustion Engine Fundamentals, John B. Heywood, 1988, ISBN 0-07-100499-8
- [2] Handbuch Verbrennungsmotoren, van Basshuysen, Richard, Schäfer, Fred, 2015, ISBN 978-3-658-04678-1
- [3] Bosch Grundlagen Fahrzeug- und Motorentechnik, Konrad Reif, 2011, ISBN 978-3-8348-8320-9
- [4] Grundlagen und Technologien des Ottomotors, Helmut Eichlseder, Manfred Klüting, Walter F. Piock, 2008, ISBN 978-3-3211-25774-6
- [5] G. Notzon, T. Busch, M. van Delden, and T. Musch: „A 500 W High Efficiency Class-E Power Amplifier for Heating a Variable Plasma Load at 10 MHz“, 10th German Microwave Conference, Bochum, DE, Mar. 2016, pp. 429 – 432
- [6] G. Armbrecht, P. Awakowicz, A. Bergner, M. Fuchs, S. Gröger, T. Musch, G. Notzon, M. van Delden, and M. Wollitzer: „Ignition Device and Method for Igniting an Air/Fuel Mixture“, WO002017207098A1, May 30, 2017.
- [7] Schiek, B. Grundlagen der Hochfrequenz-Messtechnik, 1999, ISBN 3-540-64930-1
- [8] Der neue 1,5-l-Vierzylinder-TSI-Motor von Volkswagen, Demmelbauer-Ebner, Persigehl, Görke, Werstat, MTZ, 02 2017