

PAPER • OPEN ACCESS

## Set-up of the cryogenic phase equilibria test stand CryoPHAEQTS

To cite this article: J Tamson *et al* 2019 *IOP Conf. Ser.: Mater. Sci. Eng.* **502** 012087

View the [article online](#) for updates and enhancements.



**IOP | ebooks™**

Bringing you innovative digital publishing with leading voices to create your essential collection of books in STEM research.

Start exploring the collection - download the first chapter of every title for free.

# Set-up of the cryogenic phase equilibria test stand CryoPHAEQTS

J Tamson<sup>1</sup>, M Stamm<sup>2</sup>, S Grohmann<sup>1,2</sup>

<sup>1</sup>Karlsruhe Institute of Technology (KIT), Institute of Technical Thermodynamics and Refrigeration, Engler-Bunte-Ring 21, 76131 Karlsruhe, Germany

<sup>2</sup>Karlsruhe Institute of Technology (KIT), Institute of Technical Physics, Hermann-von-Helmholtz-Platz 1, 76344 Eggenstein-Leopoldshafen, Germany

E-mail: jens.tamson@kit.edu

**Abstract.** The design of processes using cryogenic fluid mixtures requires fluid property data, which is unavailable today. In particular, this data is crucial to develop cryogenic mixed-refrigerant cycles for high-temperature superconductor (HTS) applications and to further optimize hydrogen liquefaction processes. CryoPHAEQTS, which is currently being built at KIT, will provide physical property data for fluid mixtures in a temperature range of 15–300 K and at pressures up to 15 MPa, including also mixtures with either flammable or oxidizing components (e.g. hydrogen, deuterium, oxygen). By direct sampling from an equilibrium cell, vapor-liquid equilibria (VLE) and vapor-liquid-liquid equilibria (VLLE) can be determined using gas chromatography. Solid-liquid equilibria (SLE) are measured using a calorimetric method. The measurement of heat capacities is implemented by combining two different flow measurement principles. In addition, the test stand offers optical access for a future upgrade with an optical measurement system that allows in-equilibrium measurements of both bulk transport properties by dynamic light scattering (DLS) and surface tension by surface light scattering (SLS).

## 1. Introduction

Precise physical property data of working fluids is the prerequisite of any process simulation and optimization. For vapor compression cycles commonly used in refrigeration and cryogenics, the fluid phase equilibria are of particular interest. While fluid properties of pure working fluids are available in e.g. REFPROP [1], properties of cryogenic fluid mixtures are mostly unknown apart from some binary mixture data.

Despite numerous efforts to develop predictive equations of state, experimental data is generally needed as reference points in order to fit the underlying model parameters. Several methods to measure fluid phase equilibria have therefore been developed. Dohrn et al. summarize the state-of-the-art of phase equilibria measurement techniques [2].

Following the classification in [2], an isothermal analytical approach with sampling through capillaries and gas phase circulation is used in our cryogenic phase equilibria test stand CryoPHAEQTS. An equilibrium cell containing the fluid mixture of interest is brought into isothermal conditions. Following the constant temperature, the corresponding equilibrium pressure builds up by evaporation or condensation. Once equilibrium is reached, all coexisting phases are sampled to analyze their compositions. CryoPHAEQTS allows measurements at



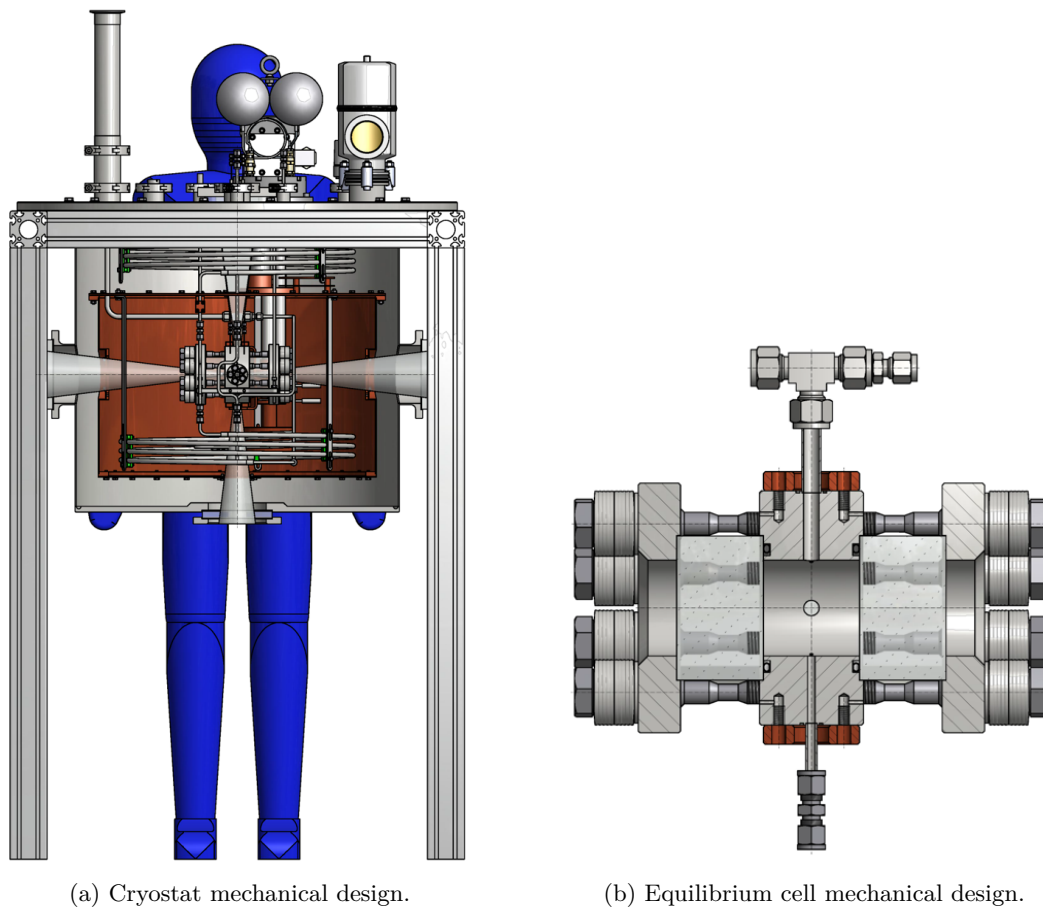

Figure 1: CryoPHAEQTS mechanical design.

temperatures from 15 K to 300 K and pressures up to 15 MPa. All non-toxic refrigerants can be investigated including oxidizing or flammable substances. The experimental results will contribute to develop cryogenic mixed refrigerant cycles (CMRC), which present an efficient cooling solution for high-temperature superconductors (HTS) and hydrogen liquefaction.

## 2. Set-up

The mechanical design of the main cryostat and the equilibrium cell is shown in figure 1. The piping and instrumentation diagram is shown in figure 2, where the instruments are indicated as tags. In the following, the mechanical design, the process design, the temperature management, the pressure measurement, the composition analysis and the measurement of the specific heat capacity are explained.

### 2.1. Mechanical design

All cold stainless steel parts are made of grade 1.4571. The cryostat vessel has a volume of 200 L and is protected with a bursting disk at  $p_{burst} \leq 0.5$  bar overpressure with regard to atmosphere. The equilibrium cell is made of a stainless steel cylinder with openings for sampling capillaries, temperature sensors and gas circulation. Both sides of the cylinder are covered with quartz glass windows that are fixed with stainless steel flanges using Helicoflex™ seals, spring washers and stress bolts. For thermalization, two copper braids are connected to the top and the bottom of the equilibrium cell.

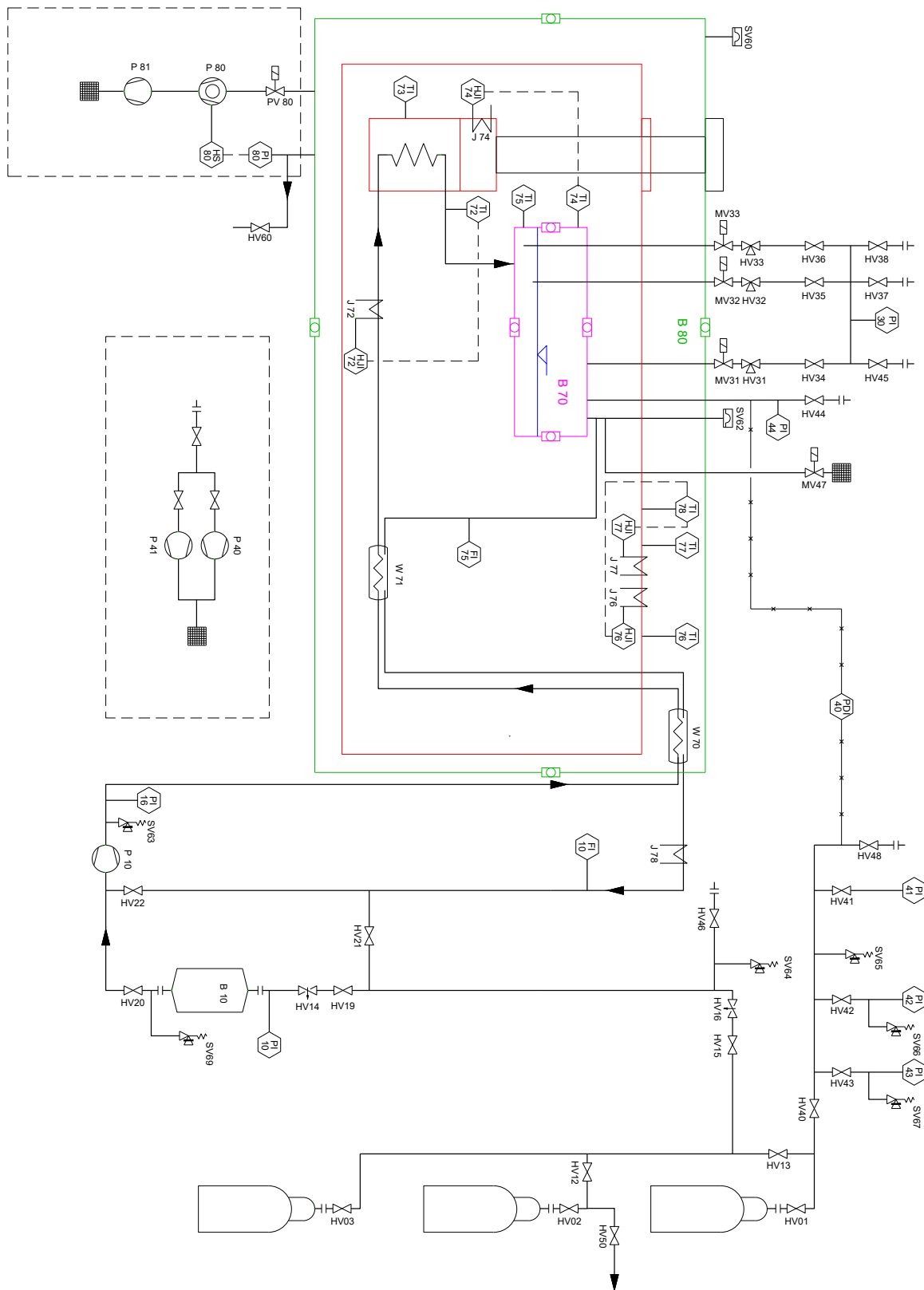

Figure 2: Piping and instrumentation diagram.

## 2.2. Process design

Gases are filled into the cycle through the high pressure valves (HV 01, HV 02, HV 03), cf. figure 2. The system can be evacuated by two vacuum pumps, one of which is oxygen compatible (P 40) and the other one (P 41) is ATEX-certified for usage with hydrogen. The gas mixture is circulated in the system by the gas circulator (P 10). It enters the cryostat (B 80) through two counter-flow heat exchangers (W 70, W 71) and is further cooled down in a tube coil attached to a pulse-tube cryocooler. The phase equilibrium emerges in the equilibrium cell (B 70). The gas phase is recirculated in order to accelerate the approach of equilibrium, pre-cooling the entering gas in the two heat exchangers (W 70, W 71). Warm-up to room-temperature is done by the electrical heater (J 78).

The determination of thermodynamic equilibrium states requires the measurement of the temperature, the pressure and all phase compositions. As shown in section 2.5, the equilibrium cell has three sampling capillaries that allow sampling from the gas phase as well as from two liquid phases. Thus, both vapor-liquid equilibria (VLE) and vapor-liquid-liquid equilibria (VLLE) can be investigated. The sampling of solid phases is not possible, but the liquidus line can be obtained by analyzing the liquid phase composition as soon as the first crystals form.

## 2.3. Temperature management

To ensure a constant equilibrium cell temperature, the heat loads by conduction, convection and thermal radiation must be minimized. The heat conduction through supports is reduced by hollow structures. Convection is avoided by placing the equilibrium cell in a high-vacuum vessel with an operating pressure of c.  $10^{-7}$  mbar. The high-vacuum pump system consists of the turbo-molecular pump (P 80), the scroll pump (P 81), the shut-off valve (PV 80) and the pressure sensor (PI 80). Heat load from thermal radiation is obstructed by an aluminum shield that surrounds all low-temperature components. The thermal shield is cooled via copper braids by the first stage of the pulse tube cryocooler that reaches 30 K at zero load. The shield temperature is controlled by two resistor heaters (J 76, J 77) placed on the top flange of the shield, and monitored at different positions by three class B Pt100 temperature sensors (TI 76, TI 77, TI 78).

The equilibrium cell is thermally anchored via two copper braids to a copper block, which is connected to the second stage of the pulse-tube cryocooler that reaches 7 K at zero load. The copper block is equipped with the electrical heater (J 74) in order to control the equilibrium cell temperature that is monitored by the two Cernox<sup>®</sup> temperature sensors (TI 74, TI 75). The additional tube coil cools the gas to a slightly higher temperature than the equilibrium cell in order to prevent unintended condensation of the feed gas. The temperatures of the fluid and the copper block are monitored by the Cernox<sup>®</sup> sensors (TI 72, TI 73) and fine-tuned by the cartridge heater (J 72).

## 2.4. Pressure measurement

Direct pressure measurement in the equilibrium cell through a capillary by the single sensor (PI 44) with a range of 0–15 MPa would yield measurement uncertainties that are insufficient for phase equilibrium measurement. Therefore, a secondary system is installed, whose working fluid is nitrogen. The pressure difference between the capillary and the secondary system is measured with the differential pressure transmitter (PDI 40). The pressure in the secondary system must hence be adjusted to the capillary pressure within the measurement range of the differential pressure transmitter by adding/releasing nitrogen. For the exact measurement of the secondary system pressure, there are three pressure sensors available that have higher accuracies in their respective measurement ranges of 5–15 MPa (PI 41), 1–5 MPa (PI 42) and 0–1 MPa (PI 43) compared to the sensor (PI 44). By using the secondary system, the sensors are not subjected

to the different working fluids that might compromise their integrity. A set-up with multiple sensors, on the other hand, would imply dead volumes that affect the phase equilibrium.

### 2.5. Composition analysis

There are three capillaries installed in three different positions in the equilibrium cell. These capillaries allow direct sampling in the  $\mu\text{L}$ -range by the ROLSI<sup>TM</sup> [3] valves (MV 31, MV 32, MV 33). The sampled volume is collected in a sampling cylinder that is evacuated and purged with the carrier gas used for the subsequent analysis by gas chromatography. Since the equilibrium cell can be operated at pressures below the threshold of 4 bar necessary for gas chromatography [4], the sample cylinder pressure can be increased by adding carrier gas as well.

### 2.6. Measurement of specific heat capacity

The specific heat capacity of the gas phase is measured by the combination of a thermal and a Coriolis flow meter. The thermal flow measurement (FI 75) is realized by the new WEKA Sense<sup>®</sup> flow sensor that works at cryogenic temperatures. Its measuring principle, which eliminates systematic errors but requires the specific heat capacity  $c_p$  as input parameter, is described in [5]. The Coriolis measurement (FI 10), on the other hand, takes place at room-temperature and yields the mass flow rate. The combination of the two sensor types hence yields the specific heat capacity  $c_p$  at constant pressure with the uncertainty of the Coriolis mass flow measurement, i.e. typically better than 1 %.

## 3. Summary and outlook

CryoPHAEQTS will deliver precise physical property data of cryogenic fluid mixtures in a broad temperature and pressure range. The phase equilibria are reached in an equilibrium cell with gas phase circulation. The temperature is measured by Cernox<sup>®</sup> sensors, the pressure through a secondary nitrogen system. After direct sampling from three capillaries in the equilibrium cell, vapor and liquid phase compositions are analyzed in a gas chromatograph.

The cryostat has six and the equilibrium cell four optical windows, offering access to optical measurements such as dynamic light scattering (DLS) and surface light scattering (SLS) in the future. Both experimental methods have already been applied to refrigerant mixtures [6]. With DLS and SLS, the transport properties (diffusivity, viscosity and thermal conductivity) as well as the surface tension can be obtained simultaneously with the phase equilibrium data. The gas circulation must be stopped in this case.

## References

- [1] 2018 Nist reference fluid thermodynamic and transport properties database (REFPROP) version 10
- [2] Fonseca J M S, Dohrn R and Peper S 2011 *Fluid Phase Equilibria* **300** 1–69
- [3] Guilbot P, Valtz A, Legendre H and Richon D 2000 *Analysis* **28** 426–31
- [4] Dettmer-Wilde K and Engewald W 2014 *Practical Gas Chromatography* (Springer)
- [5] Grohmann S 2014 *Cryogenics* **60** 9–18
- [6] Froeba A P and Leipertz A 2003 *Int. J. of Thermophysics* **24** 1185–1206

## Acknowledgements

The authors would like to acknowledge the support from the Karlsruhe School of Elementary Particle and Astroparticle Physics: Science and Technology (KSETA).