

# Photonics in Switching

We may not have pure photonic switching by the year 2000, but the new millenium's broadband hardware cannot be connected without photonic help.

•••••

H. Scott Hinton

One of the keys to the future of telecommunications companies will be their ability to provide new broadband services to both the business community and the residential customer. These new services include the transport of National Television Standards Committee (NTSC) video, enhanced quality television (EQTv), high-definition television (HDTV), switched video, high-data-rate file transfers, information retrieval, and animated graphics, in addition to being an interconnect for diskless workstations and local area networks/metropolitan area networks (LANs/MANs) [1]. With these new services will come the need for the equivalent of a broadband switching office. Such a system could require the capability of supporting in excess of 10,000 users with broadband channel bit rates exceeding 100 Mb/s. This implies a switching fabric the aggregate bit rate of which could be greater than 1 Tb/s. This fabric, or collection of different fabrics, could have to support both the conventional circuit-switching capabilities, as they currently exist on the network, and control packet services, such as ATM cells embedded in Synchronous Optical Network (SONET) streams of data, at perport costs similar to existing plain old telephone service (POTS). The hope of photonic systems is that, through the application of either the temporal or spatial bandwidth available in the photonic domain and the new architectures and fabrics that are conceived, these broadband systems and services will be economically realized [2].

## Strengths of the Optical Domain

Research in photonic switching fabrics can be categorized as systems based on either guided-wave or free-space optics. Typically, guided-wave optics have been concerned with the application of optical fiber and the utilization of the large temporal bandwidth available in guided-wave structures such as optical fiber, star couplers [3], and directional couplers [4]. This bandwidth transparency provides large-bandwidth analog channels, which can be used to transport many channels of digital

information. As an example, current single-mode optical fiber supports approximately 25 THz of communications bandwidth around the 1.5  $\mu\text{m}$  wavelength region. This offers the opportunity to multiplex many users, through either time division or spectral division, onto a single-mode fiber, thus reducing the cost per user of the required system hardware. Therefore, researchers have pursued both time-based switching fabrics (photonic time-slot interchangers and multiple access schemes such as time-division multiple access and code-division multiple access), and wavelength-based fabrics (wavelength interchangers and both wavelength-division multiple access and spectral code-division multiple access). Arguments for guided-wave optics include:

- Natural evolution from today's electrical technology, since it can integrate directly with electrical transmission lines
- Building on the existing fiber base present in the telecommunications network
- Many guided-wave optically transparent devices demonstrated in the laboratory
- Supporting optically transparent switching fabrics
- More developed and better understood technology than the free-space technology

Free-space optics, on the other hand, has been more concerned with using the available spatial bandwidth to increase the intrasystem connectivity and reduce the limiting effects of buses, low pin-out integrated circuits (ICs), printed circuit boards (PCBs), and multi-chip modules (MCMs). This approach is more concerned with extending the life of the electronics technology through the use of optical pin-outs and/or interconnects than replacing it. This new technology could be an important aid to electronics technology, since many of the high-performance high-density integrated circuits are pin-out-limited. This pin-out limitation forces unnatural system partitioning and limits architectural considerations in both computing and switching systems. Although there has been considerable progress in electronic packaging, such as C4 (flip-chip) and TAB bonding techniques [5], using light as a communications medium may be preferred, because light has been shown to be more energy-efficient when

---

H. SCOTT HINTON is head of the Photonic Switching Department at AT&T Bell Laboratories.

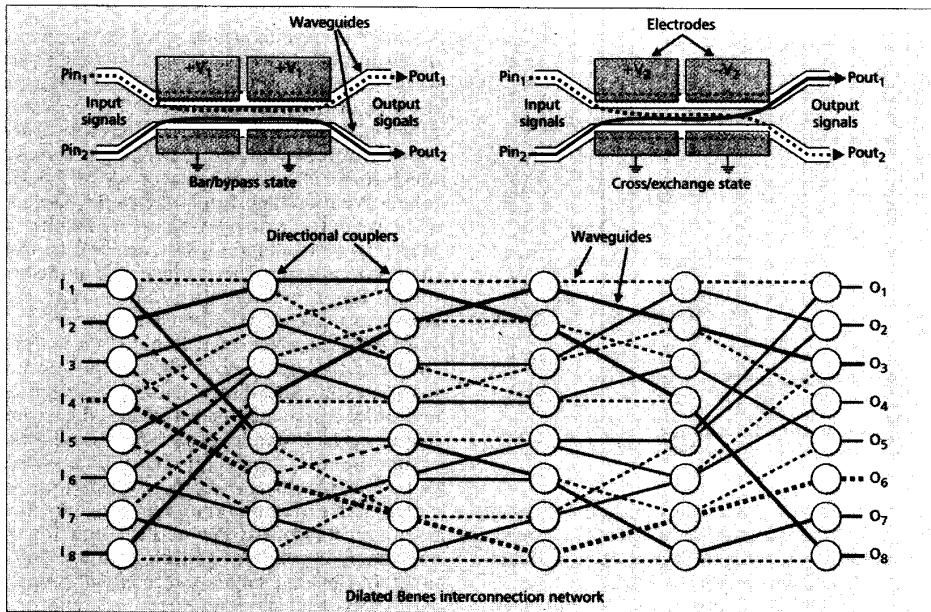

■ **Figure 1.** Directional coupler operation and interconnection network application.

the distance between communicating elements is greater than 1 mm. Work in this research area ranges from PCB-to-PCB interconnects to gate-to-gate interconnection of optical logic gates.

Research in free-space optics has been focused on multi-stage space-division switching fabrics, particularly large-dimension fabrics, where the need for a large number of connections is evident. The experimental work done to date has used symmetric SEED (S-SEED) arrays [6] as the switching nodes in the network, with bulk optical elements providing the optical interconnects required by the multi-stage networks. Other proposed switching nodes for these fabrics include other optical logic gates, such as optical logic etalons (OLEs) [7], nonlinear interference filters (NLIFs) [8], double heterostructure optoelectronic switches (DOESs) [9], vertical surface transmission electro-phonic (VSTEP) device arrays [10], or 2-D arrays of "smart pixels" in which the functionality of many nodes are integrated onto a single electronic IC [11]. Due to the potential large-scale integration of the switching nodes on each array (up to  $10^4$  nodes per array), this approach should eventually reduce the hardware cost of such a fabric and provide the capability of implementing a large-dimension switching fabric that could be used as either a packet or time-multiplexed switch. Leading-edge research in this area is currently exploring both the performance and cost issues associated with switching fabrics as a function of the granularity of the optical interconnects and the intelligence of the nodes. The potential advantages of this free-space interconnect technology include:

- Providing another dimension of freedom in routing signals.
- Potentially provides high integration density.
- Providing low power dissipation per pin-out.
- Inherent parallel structures can reduce latency. Through the development of new architectures and fabrics utilizing the parallelism of the available spatial bandwidth, new high-performance low-cost systems could emerge.

## Guided-Wave Technology

The guided-wave technology industry has focused its attention on the development of devices and systems that take advantage of the large bandwidth available in optical fiber. The desire to provide high-performance analog channels between users has led to switching fabrics that use and preserve this bandwidth transparency. To begin this section, there will be a review of directional-coupler-based space-division fabrics. There will then be a discussion of three proposed time-division-based switching fabrics. This will be followed by a brief description of two wavelength-division-based switching fabrics. Finally, there will be two multi-division fabrics discussed.

### Space-Division Fabrics

For over fifteen years, the mainstay of space-division guided-wave switching devices has been the directional coupler [12]. A directional coupler is a device that has two optical inputs, two optical outputs, and one control input, as shown in Fig. 1. The control input is electrical and has the capability of putting the device in the bar or bypass state—the upper (lower) optical inputs are directed to the upper (lower) optical outputs—or the cross (exchange) state—the upper (lower) optical inputs are directed to the lower (upper) optical outputs. The most advanced implementations of these devices have occurred using the titanium-diffused lithium niobate ( $\text{Ti:LiNbO}_3$ ) technology, although there has been some effort in building these structures in the gallium arsenide (GaAs) and InP/InGaAsP material systems.

The strength of directional couplers is their optical transparency, which provides the ability to control extremely-high-bit-rate information. Their use is limited by several factors: the electronics required to control them limits their maximum reconfiguration rate; the long length of each directional coupler prevents large-scale integration; and

.....  
*Research in free-space optics has been focused on multi-stage space-division switching fabrics, particularly large-dimension fabrics.*

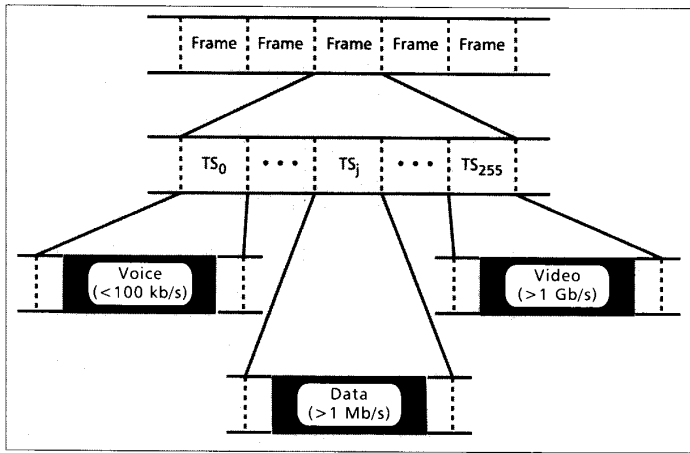

■ Figure 2. Universal time slots.

the losses and crosstalk associated with each device limit the maximum size of a possible network, unless some type of signal regeneration is included at critical points within the fabric.

Since directional couplers are  $2 \times 2$  nonblocking switches, they can be linked together to create larger interconnection networks. For point-to-point networks, the interconnection of these  $2 \times 2$  switching nodes can be accomplished using Clos, Benes, dilated Benes [13], banyan, omega, or shuffle network topologies [14]. As a result of the analog nature of directional couplers, they are susceptible to crosstalk between channels and signal loss. These noise and loss constraints limit the size of fabrics that can be built using these devices. To avoid the loss limitations, rearrangeably nonblocking networks such as Benes and dilated Benes networks have been pursued because their

total loss is logarithmically related to the size of the switch,  $O(\log_2 N)$ , as opposed to crossbar networks, the losses of which are linearly related to the size of the network,  $O(N)$ . The crosstalk problem, on the other hand, is reduced by choosing more robust networks, the control schemes of which do not allow both inputs of any  $2 \times 2$  device to be active at any time. In these networks, one input will have active information present while the other input will contain only the crosstalk noise from the previous stage. This is illustrated at the bottom of Fig. 1, where the solid lines represent active signal lines and the dotted lines are crosstalk noise. Note that all the couplers in any activated path have only one input active. Thus, as the information passes through a directional coupler, only a second-order crosstalk term can corrupt the desired output signal. Examples of such networks include dilated Benes, Ofman [15], and EGS networks [16]. This implies that the analog-type problems associated with directional-coupler networks have been architecturally avoided to allow for the implementation of large switching fabrics. Unfortunately, the long length of directional couplers and the large bending radii required in the integrated waveguides will limit the integration density of directional couplers to small networks less than  $32 \times 32$ . These smaller networks will then need to be interconnected to create the larger-dimension fabrics required for the future.

A good application of directional-coupler-based fabrics is a protection switch for fiber transmission facilities. In this environment, the only time the switch will need to be reconfigured is when a failure occurs in an existing path. Thus, high bit rates can be passed through the switch with moderate reconfiguration-rate requirements.

### Time-Division Fabrics

As a result of the large signal bandwidth available in optically transparent devices, the signal bit rate passing through the device can be much larger than the bit rate of any single user. In this situation, the information from the users can be compressed (in time) and share the transparent devices with many other users. There will be two types of time-division switching fabrics discussed in this section. The first two will be time-slot interchangers (TSIs), which actively rearrange the time slots in channels of time-multiplexed information. The third time-division-based switching fabric uses multiple access techniques to use the available temporal bandwidth of a star coupler.

A conventional time-division multiplexed (TDM) signal is normally composed of either a bit-multiplexed or block-multiplexed stream of information. A bit-multiplexed data stream is created by interleaving the compressed or sampled bit-synchronized bits from each of the users. This type of multiplexing is the method of choice for most transmission systems, since it requires the storage of only one bit of information for each user at any time. Unfortunately, most of the bit-multiplexed transmission systems are further complicated by adding pulse-stuffing and other special control bits to the data stream. Block-multiplexing, on the other hand, stores a frame's worth of information from each of the users and then orders the bits entering the channel such that each user's data is contiguous.

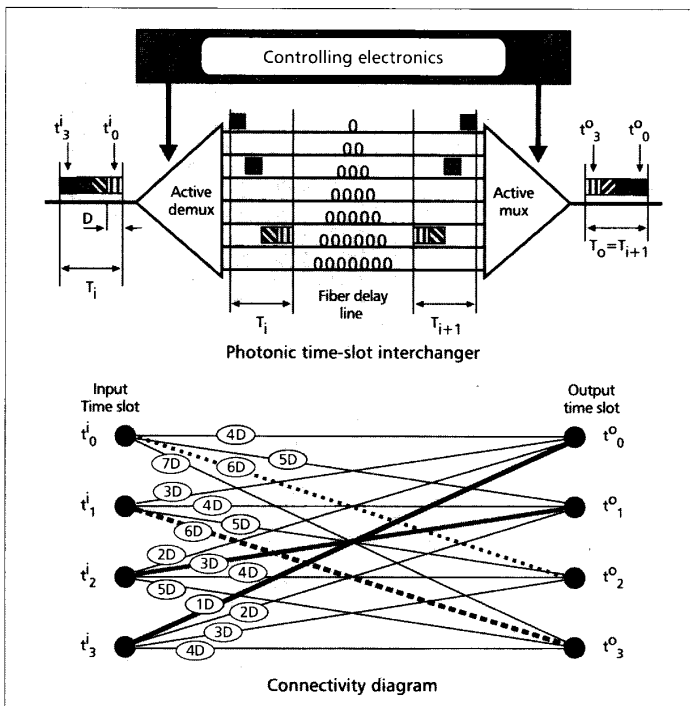

■ Figure 3. Fiber-delay-line-based TSI.

When used in a switching environment, block multiplexing requires the switching fabric to reconfigure only at block boundaries instead of bit boundaries, as in the case of bit-multiplexed data streams. By allowing a small amount of dead time between the block-multiplexed information, the requirements on the reconfiguration time of the fabric can be relaxed. This can be attractive for switching devices such as directional couplers, which, when fabricated into large switching arrays, have slow to moderate reconfiguration times.

A good application of the bandwidth transparency of optical fiber is through the use of universal time slots [17]. A universal time slot is a partitioned section of time, which can contain information transmitted at any bit rate (see Fig. 2). In this figure, a frame is composed of 256 time slots. Each time slot can contain information at any bit rate. For example, a time slot of voice would require approximately 100 kb/s, while an adjacent time slot could contain video information at a bit rate in excess of 1 Gb/s.

**Time-Slot Interchangers**—Switching can be achieved by interchanging the position, in time, of the time slots in a frame of time-multiplexed information. Most of the proposed photonic TSIs have been single-stage structures, in that the time slots of the input frame are directly mapped into the desired time slots of the output frame through the use of variable-length delay lines [18].

An example of such a TSI is shown in Fig. 3. In Fig. 3a, a time-multiplexed information stream with four time slots of duration  $\Delta$  comprise an input frame  $T_i$ . The output frame  $T_o$  leaving the TSI is delayed by one frame delay (for this example,  $T = 4\Delta$ ). To perform the TSI function, each of the input time slots is directed to the appropriate number of time-slot delays to reposition it into the desired output frame time slot. By comparing the input frame,  $T_i$ , to the output frame,  $T_o$ , it can be seen that the following interchanging of time slots has to take place:  $t_0^i \rightarrow t_3^o$ ,  $t_1^i \rightarrow t_2^o$ ,  $t_2^i \rightarrow t_1^o$ , and  $t_3^i \rightarrow t_0^o$ . The connectivity graph for this type of TSI is shown in Fig. 3b. This bipartite graph representation assigns the input and output time slots as the vertices (dots) and the edges as delays. The switching between time slots is achieved by choosing the appropriate delay, which creates a virtual channel between an input and output time slot. As an example, for the information in  $t_3^i$  to be switched to  $t_0^o$ , the delay line of  $1\Delta$  must be used. The thick lines represent the connections shown in Fig. 3a. Since there is a path between any input time slot and any output time slot, this single-stage network is fully connected. Also, since there are unique paths from each input time slot to each output time slot, the time-based network is also nonblocking.

Another approach to the implementation of a TSI is to move the input time slots through multiple stages of intermediate time slots prior to arriving in their desired output time slot [19]. For these structures, each stage does not have to be either fully connected or nonblocking. An example of a time-based butterfly interconnect is illustrated in Fig. 4. In the upper half of this figure, the hardware and connectivity graphs for two different periods of butterfly are illustrated. The three different delays are accomplished by either passing the information directly

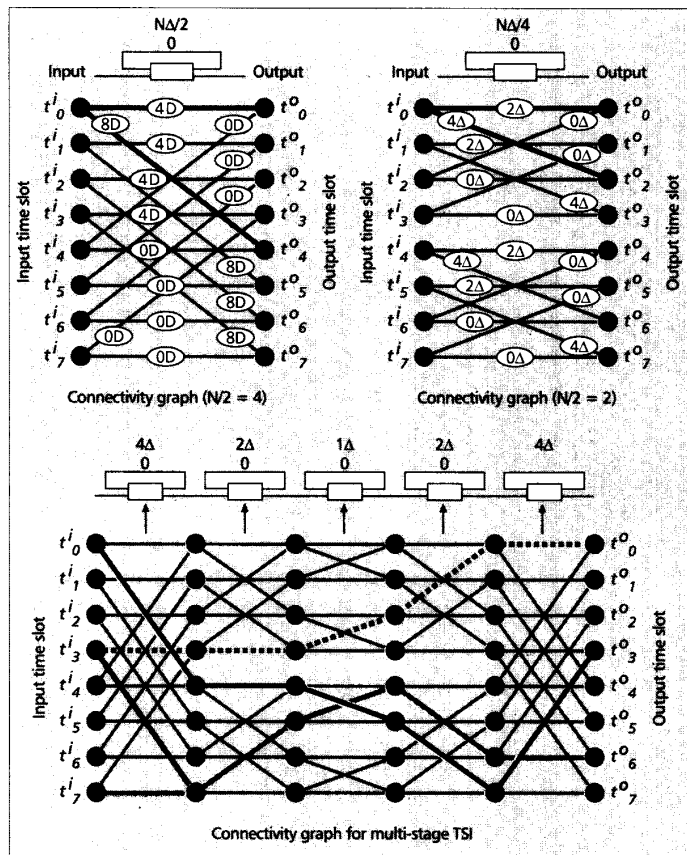

Figure 4. Multi-stage TSI.

from the input to the output, passing through the fiber delay line once ( $N\Delta/2$ ), or passing through the delay line twice  $N\Delta$ .

Through the use of multiple stages of time switches with different delays, the rearrangeably nonblocking Ofman network can be implemented [20]. This is illustrated in the middle of Fig. 4. It is composed of  $2\log_2 N - 1$  serially connected exchange/bypass nodes (directional couplers) and their associated delay lines. The connectivity of an  $8 \times 8$  multi-stage TSI is shown at the bottom of the figure. Three active paths are shown through the network.

**Multiple-Access Fabrics**—The time-based switching fabrics previously described assume that the users are time-multiplexed onto a single space channel, with each user associated with a particular time slot. The switching operation is provided by an active reconfigurable fabric that interchanges the temporal position of the time slots.

Thus, rearranged time-multiplexed information is then demultiplexed and delivered to the users. This process allows the creation of virtual connections, in time, between users. Multiple-access fabrics, on the other hand, provide a physical connection between all users with a global interconnect such as a bus or star coupler. This physical connection is then shared among all users in time to avoid contention. Ring networks are examples of switching fabrics based on a passive shared medium. The passive shared medium is typically

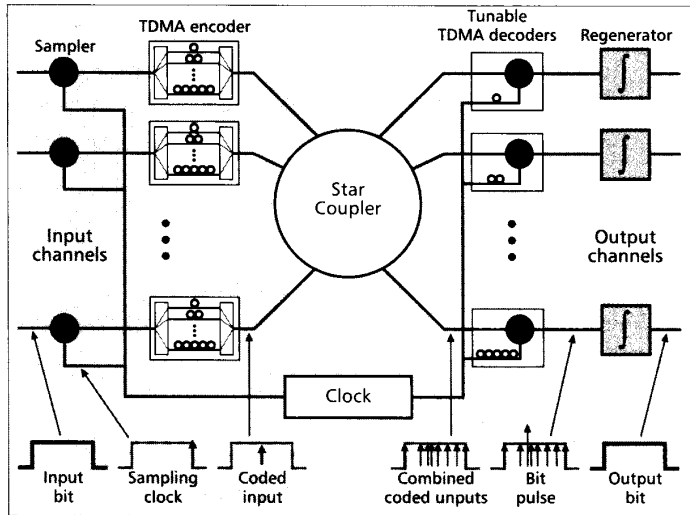

■ Figure 5. TDMA switching network.

an optical fiber accessed in time with either passive taps such as fiber couplers or directional couplers operating as active taps. For a synchronous ring structure, each user is assigned a unique piece of time (time slot) to read the information from the ring. Other users can send information to a user by entering information into the destination user's time slot. Access to the time slots is arbitrated by some form of centralized control. There are also many other schemes for using ring structures in switching applications, both with centralized control and distributed asynchronous control schemes based on packet structures [21].

Instead of using a single fiber as the shared passive media, a star coupler can be used. A star coupler is a device with  $N$  inputs and  $N$  outputs that combines all the input channels and redistributes them equally to all the outputs. A time-division multiple access (TDMA) fabric could then consist of time encoders on each input, the star coupler to combine and redistribute all the input signals, and finally, time decoders to select which input should be received. A fabric is referred to as a fixed-transmitter assignment (FTA) network if the encoders or transmitters are fixed, and the decoders or receivers can be adjusted to select any input. Conversely, a fixed-receiver assignment (FRA) network has fixed receivers and tunable transmitters [22].

An example of an FTA multiple-access net-

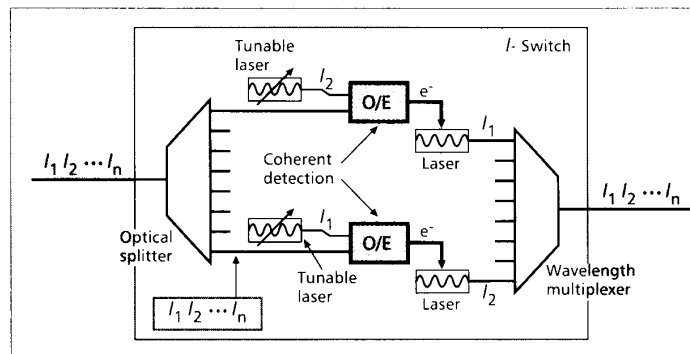

■ Figure 6. Wavelength interchanger.

work is illustrated in Fig. 5. For this fabric, the address associated with each output channel is the position, in time, of the sampled input signal. Thus, the effective address for the upper output channel is one unit of delay, while the address of the lower output channel is  $N$  units of delay. In this figure, all synchronous inputs are sampled and directed to a tunable TDMA encoder. The TDMA encoder sets the appropriate delay for the sampled input to match the delay required by the desired output channel. The outputs from all the TDMA encoders are then combined and distributed to all the decoders. Each decoder delays the clock signal the appropriate amount and then incoherently combines it with whatever light is present. If a sample is present, the combination of the delayed clock and the sample will combine to trigger a thresholding device, which will indicate that a bit is present. The sample will then be converted to a bit of the proper duration.

### Wavelength-Division Fabrics

Like the time-division fabrics discussed, fabrics based on wavelength channels can either rearrange or reconfigure the information present on the different wavelengths or share those wavelength channels through multiple-access techniques. This section will begin with a discussion of a proposed wavelength interchanger (WI). It will then be followed by a review of the work on switching fabrics based on multiple access to wavelength channels.

**Wavelength Interchanger**—Just as in the case of a TSI, where a switching function can be performed by interchanging the time slots in a time-multiplexed information stream, a WI can provide a switching function for a wavelength-multiplexed channel, as shown in Fig. 6 [23].

In this figure, a wavelength-multiplexed signal enters the  $\mu$ -switch. Since each user is associated with a unique wavelength, a connection can be made between two users by converting the transmitter's wavelength ( $\lambda_t$ ) to the receiver's wavelength ( $\lambda_r$ ). The wavelength-division multiplexed (WDM) signal enters the  $\lambda$ -switch, where the power is equally divided among  $n$  channels. Each of these channels will go through a coherent detection process in which the information on the desired input wavelength can be detected. This information is then used to modulate a fixed-output wavelength laser. The outputs of the fixed lasers, all of different wavelengths, will be combined onto a single fiber.

As a specific example, assume the information modulated on  $\lambda_n$  needs to be moved to the carrier  $\lambda_1$ . The fabric control will adjust the tunable laser associated with the fixed laser generating the  $\lambda_1$  carrier. This tunable laser will select the information on  $\lambda_n$ . This information will then modulate the fixed output laser of wavelength  $\lambda_1$ . Thus, the information on  $\lambda_n$  has been transferred to  $\lambda_1$ .

Figure 7 illustrates how a collection of WIs can be interconnected to create a larger-dimension fabric. The WIs are connected into a three-stage fabric through the  $\lambda$ -multiplexers and  $\lambda$ -demultiplexers. Since the combination of the  $\lambda$ -multiplexer, the  $\lambda$ -switch, and the  $\lambda$ -demultiplexer is equivalent to an  $n \times m$  switch, known network topologies can be used to create larger switching fabrics. As an example, a Clos network using this approach is shown in Fig. 7.

**Multiple Access Fabrics**—Another type of star-coupler-based architecture that has received a considerable amount of attention is wavelength-division multiple access (WDMA). This is schematically shown in Fig. 8. In this figure, the entering information is used to modulate a light source that has a unique wavelength associated with each input. The optical energy from all the input sources is combined and redistributed by a star coupler to all the output channels. The tunable filter on each output is tuned so that only the wavelength associated with the desired input channel can pass to the detector.

Thus, by varying the tunable filter, an output has access to any or all of the input channels. Several approaches to the tunable filters have been pursued. The first is to use movable gratings [24]. A second type of tunable filter could be a tunable Fabry-Perot etalon [25]. Finally, coherent detection could be used as the mechanism to select the desired wavelength [26].

#### Multi-Divisional Fabrics

In the early days of telecommunications switching, the switching fabrics used were space-division. With the advent of digitized voice, it became apparent that electronic hardware in the fabric itself could be reduced by adding the dimension of time to the space-division fabric. As an example, if a 1024 x 1024 space-division switch was able to switch 128 time slots/frame (1 frame = 125  $\mu$ s), then a switching fabric with a dimensionality of approximately 128,000 x 128,000 could be made (c.g., 4ESS<sup>TM</sup>).

An example of a potential 512 x 512 time-space-time (TST) switch is shown in Fig. 9. In this figure, the input lines are partitioned into sections of 32 lines, which are time-multiplexed onto a single space channel. Thus, each channel consists of 32 time slots. If the bit rate of the input signals is 150 Mb/s, then the time-multiplexed information stream will require a bit rate > 4.8 Gb/s ( $\approx$ 208 ps/b). This time-multiplexed signal then enters the TSI, where the 32 time slots can be interchanged. From there, the information enters the time-multiplexed space-division switch. (The advantage of multi-dimension switching is that the size of the space switch can be small.) The output of the space switch is directed to the output TSI, which is then demultiplexed to the output space channels. The difficulty with TST configurations is the timing requirements imposed upon the centralized control. As an example, to avoid any phase discontinuities on the output channels from the space switch, the time-multiplexed information stream entering the 16 x 16 switch must be bit-aligned. Assuming a 5-Gb/s bit rate implies that each bit has a pulse duration of 200 ps. Thus, to prevent these phase discontinuities on the output channels, all the input bits should be bit-aligned to within 10 ps of each other. This timing burden will be placed on the initial time-division multiplexer, or an elastic store will have to be placed on the input to the space switch (assuming that the controlling electronics can recognize variations of  $\approx$ 10 ps). To illustrate the critical packaging problem, if the length of fiber from 2 TSIs differs by 1 cm (assuming an index of refraction of 1.5 in the fiber), there will be a 50-ps difference in the bit arrival times at the space switch. In addition to the bit and frame alignment required by the space switch, each TSI will require

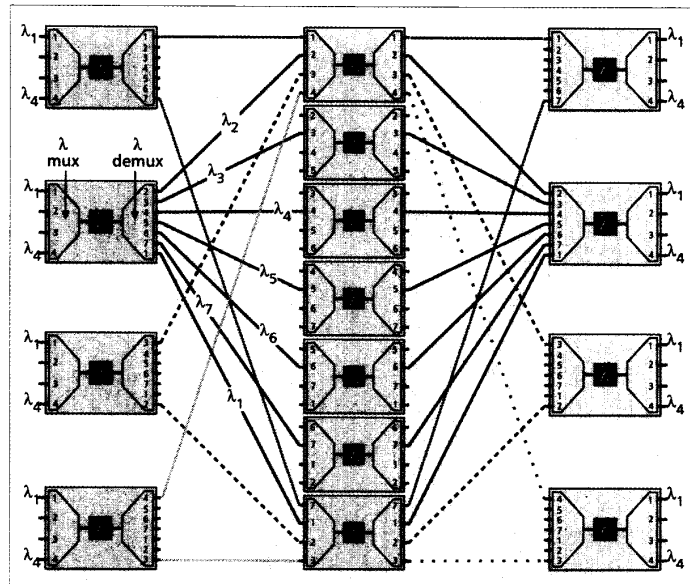

Figure 7. Clos multi-stage switched-wavelength network.

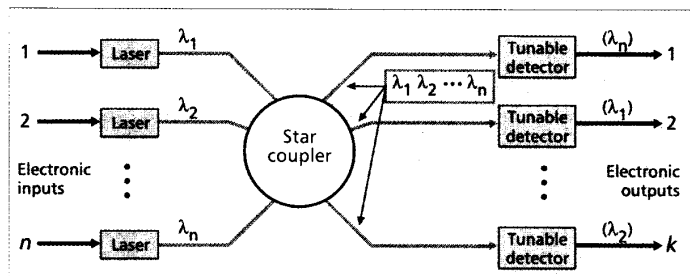

Figure 8. WDMA fabric.

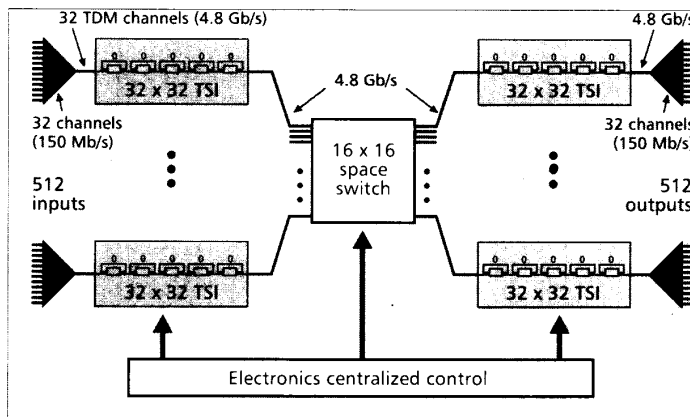
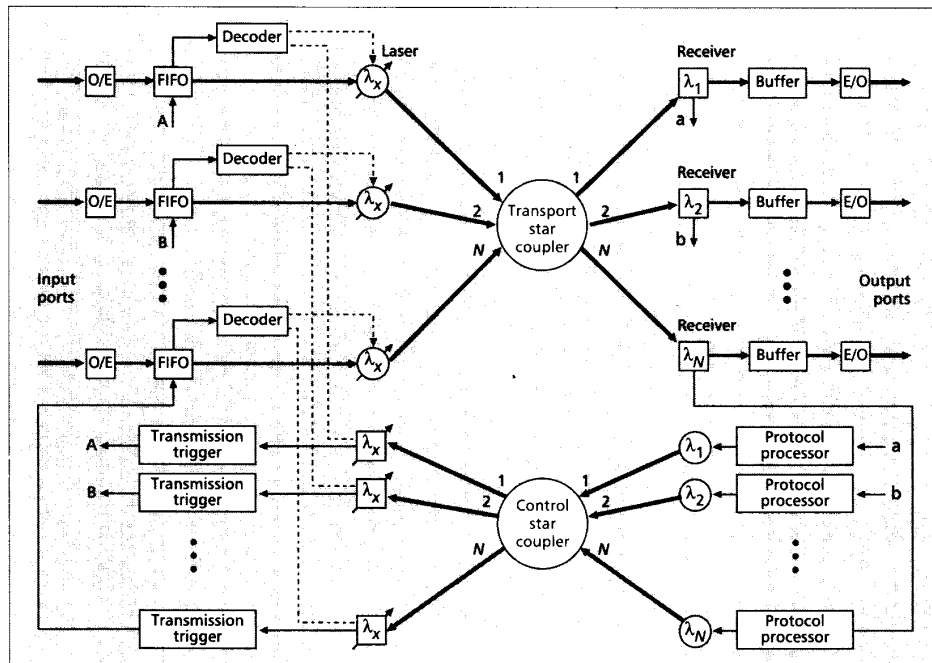

Figure 9. TST photonic fabric.

the alignment of bit and frame boundaries to prevent phase discontinuities on its output channel. The strength of the multi-dimension switching structures, such as this TST switch, is the minimal amount of hardware needed to build them. The cost is increased timing complexity.

Another example of a multi-dimension fabric is a packet switch. Such a switch is basically a space-division fabric, which can reconfigure itself rapidly to allow the sharing of space channels in time. HYPASS is an example of a packet-switching

.....  
 The main objective of free-space technology is to exploit the spatial bandwidth (pin-outs or connections) available in the optical domain.



■ Figure 10. HYPASS fabric.

fabric proposed using WDMA (see Fig. 10) [27]. In this fabric, the packetized information enters the fabric from the left, where it is initially stored in a first-in first-out (FIFO) buffer. The objective is to modulate the tunable laser tuned to the fixed wavelength of the designated output port, pass the information through the transport star coupler, and then receive the information at the desired output port. Prior to accessing the transport star coupler, it is necessary to check to see if the desired output port is busy. This is accomplished through the specialized control hardware. If an output port is available, the protocol processor associated with the fixed-wavelength receivers will turn on the laser associated with the particular output port, allowing light to enter the control star coupler. The tunable receivers attached to the control star coupler can tune to the wavelength of any of the output channels; if the signal is present, it will signal the input channel decoder to tune the laser to the appropriate wavelength and then command the FIFO to send the current packet to the desired output channel. Note that in this fabric, the packet address is converted to the specific wavelength of the output channel. Thus, the address in the fabric is the wavelength of light entering the transport star coupler.

### Free-Space Technology

The main objective of free-space technology is to exploit the spatial bandwidth (pin-outs or connections) available in the optical domain. This has allowed researchers to look for connection-intensive switching fabrics, as opposed to maximizing the available bandwidth in a limited number of connections (temporal bandwidth). The devices used in these free-space structures could be either large two-dimensional (2D) arrays of optical logic gates, such as S-SEEDs, VSTEPs, and NLIF, or

2D optoelectronic integrated circuits (2D-OEICs) or "smart pixels." 2D-OEICs in this case are devices composed of electronics (transistors) for information processing and photonics (e.g., detectors, modulators, lasers, and LEDs) for transporting the information between ICs. The optics used to interconnect free-space devices could be composed of either holographic elements or bulk optical elements such as lenses and mirrors. This section will begin by reviewing the "fine-grain" space-division fabrics associated with S-SEED devices. This will be followed by a discussion on how 2D-OEICs or smart pixels could be used as the building blocks for larger and more complex switching fabrics.

### S-SEED Devices and Systems

The S-SEED is a device with two inputs and two outputs, as shown in the upper half of Fig. 11. This device is composed of two multiple quantum well (MQW) p-i-n diodes electrically interconnected in series. When the diodes are connected in this fashion they become complementary, in that when one of the diodes is "on" the other will be "off." Thus, one of the diodes will be in the absorbing state while the other is in the transmissive state. This is illustrated in the characteristic curves shown in the figure. Perhaps the greatest strength of these devices is that changing states is a function of the ratio of the two input powers and not of the absolute intensity of the input beams. The optically bistable loop is centered around the point where the two inputs,  $P_{in0}$  and  $P_{in1}$ , are equal. From these figures, it can be seen that the device will remain in its current state until that ratio exceeds 1.3 or is less than 0.7. The importance of ratio switching is that the allowable noise on the signal inputs can be much greater than for a critically biased device.

The S-SEED can be configured such that it can operate as an S-R latch. This is illustrated in

the bottom half of Fig. 11. The inputs are separated into an  $S$  (Set) input,  $R$  (Reset) input, and a clock input, where the clock has approximately the same intensity for both inputs. The  $S$  and  $R$  inputs are also separated in time from the clock inputs, as shown in this figure. The  $S$  or  $R$  inputs are used to set the state of the device. When the  $S$  input is illuminated, the S-SEED will enter a state where the upper MQW p-i-n diode will be transmissive while the lower diode will be absorptive. When the  $R$  input occurs, the opposite condition will prevail. Since the energy required to change the state of the devices is a function of the ratio of the  $S$  and  $R$  inputs, when only one of these two inputs occurs diminished switching intensities are needed to change the device's state. After the device has been put in its proper state, the clock beams are incident on both inputs. Since the two clock beams are roughly equivalent in intensity, the ratio between the incident beams should be close to one, which will prevent the device from changing states. This higher-energy clock pulse will be used to transmit the state of the device to the next stage of the system. Since the  $S$  or  $R$  inputs are low-intensity pulses and the clock is a high-intensity pulse, a large differential gain, referred to as "time-sequential gain," may be achieved. These devices can also be operated as optical logic gates, such as OR, NOR, AND, and NAND, which allows them to be used to implement any digital switching node.

Using these devices as optical logic gates, different types of digital switching nodes can be implemented, as illustrated in Fig. 12 [28]. The triplet notation shown in this figure represents the following: number of inputs, number of outputs, and capacity of the node. The first two parameters of the triplet represent the number of inputs and outputs, while the third parameter indicates the number of channels that can be actively passed through the node at a given time. The (2,2,2) node has two inputs and two outputs, with the capability of having both inputs and outputs simultaneously active at any time. This node is topologically equivalent to a directional coupler; but since it is composed of digital gates, it does not have the bandwidth transparency of its analog counterpart. The (2,2,1) node in the center of the figure has two inputs and two outputs, although both outputs contain the same information; hence, the node has a capacity of one. In this node, the input AND gates select which input channel can pass its contents to the outputs. These nodes work well in networks designed to guarantee that only one input to a given node can be active at any time. Such networks include dilated Benes, Ofman, and EGS networks. Finally, there is the 2-Module, which is a simpler version of a (2,2,1) Node. This node also requires that the network guarantee that only one node input is active at any time, but is more restrictive than the previously described node. Since this node cannot block signals entering on the inputs, it requires that no signal be present on the unused input line.

An S-SEED can be used as a 2-Module, since it stores whatever information is presented to it from the previous stage in the network during the read cycle and then passes that information to the next stage when the clock signal is applied to it. To block a signal from passing through the S-SEED 2-Module, the clock signal is withheld from the

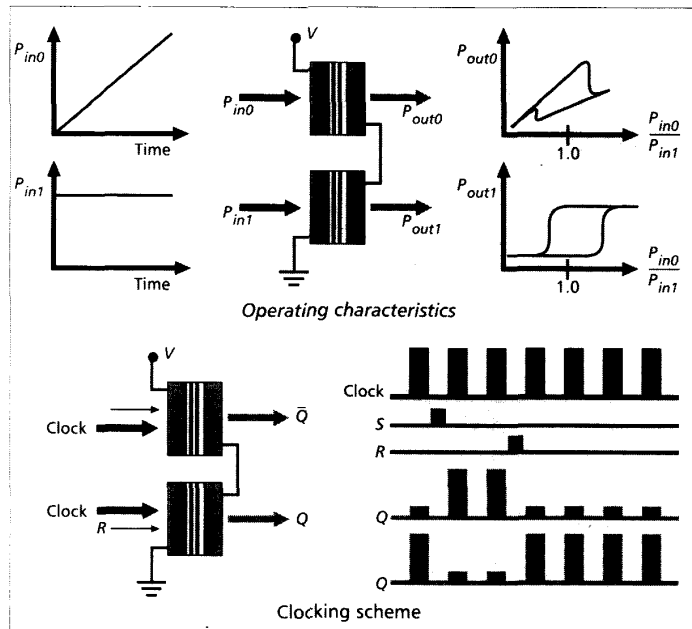

Figure 11. S-SEED operation.

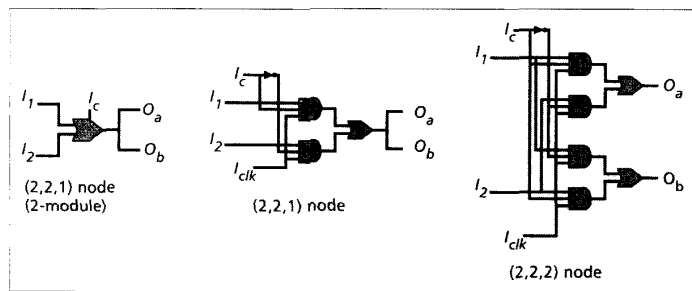
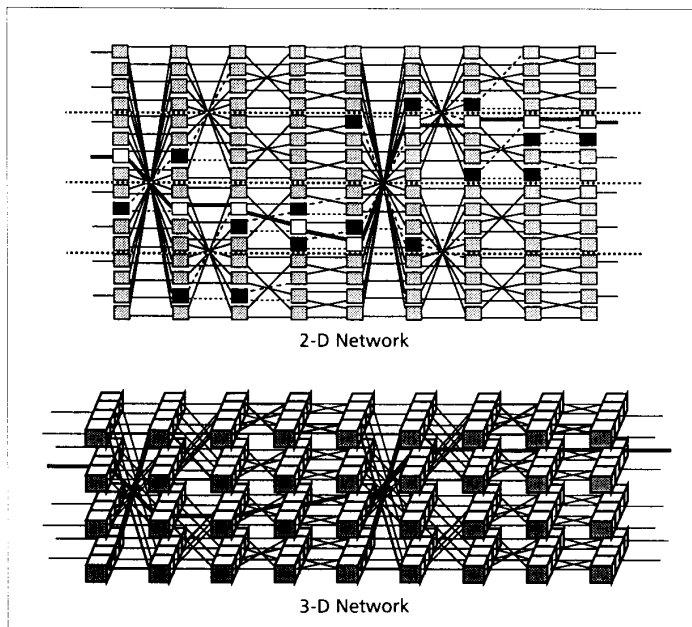

Figure 12. Switching nodes using logic gates.

previous device, thus preventing the stored information from transferring to the next stage in the network. This blocking or inhibiting of selected S-SEEDs could be accomplished through the use of a spatial light modulator to control which devices receive clock signals. An example of a multi-stage EGS network using 2-Modules is shown in Fig. 13. The upper half of the figure illustrates the 2-D EGS-crossover network. To convert this 2-D network to a 3-D network, the 2-D network is fan-folded at the dotted lines [29]. This creates a 3-D network using 2-D interconnects between the stages. Note that there are four independent crossover interconnects in the first stage, each lying in a vertical plane. The second crossover stage also forms a vertical plane. On the other hand, the interconnects in the third and fourth stages lie in horizontal planes.

To set up a path through the network, the thick lines—clock signals—are allowed to transfer information from the active nodes in a given stage to the next stage. Since the nodes are 2-Modules, only one of the two inputs present on each node can be active at any given time. To prevent corruption of the data entering the 2-Modules (S-SEEDs), the outputs of the undesired nodes are disabled by not receiving a clock signal, thus preventing a transfer of the information they contain. These disabled nodes





■ Figure 13. EGS-crossover interconnection networks.

are shown in black in the figure. Note that there is a complementary couple between each stage, composed of the active nodes and the disabled nodes. Thus, once a path through the network has been determined, the disabled nodes are easily determined as the unused nodes in the complementary couple. The path through the 3-D network is shown by a thick line at the bottom of the figure. A picture showing the optics that demonstrated the first six stages of a 32-bit-wide 32 x 32 network is shown in Fig. 14[30, 31]. Such a 32x32 EGS network would require 13 stages to be strictly nonblocking. The potential advantage of these fine-grained switching fabrics is that large-dimension fabrics could be possible in the future. As an example, a 1024 x 1024 non-blocking EGS fabric could be demonstrated using 19 S-SEED (64 x 128) arrays and their associated optical hardware [32].

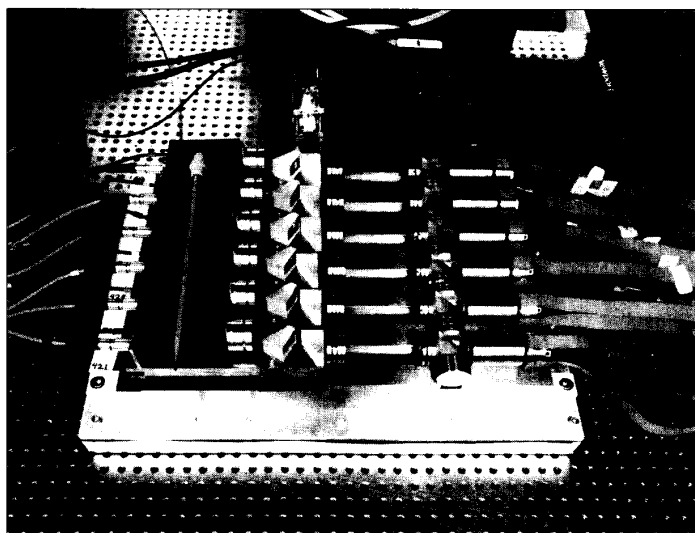

■ Figure 14. Telecom '91 fabric.

The strength of S-SEED devices is that large arrays of small devices with uniform characteristics can be fabricated—128 x 256 (32K) arrays have been fabricated. The weakness is that they require too much energy to operate. At the current time, these devices require approximately 1 pJ of energy to change states. Since these devices switch as a function of energy, this high switching energy will limit the system speed. In addition, there is still a large amount of research required to understand the packaging of these devices and their required hardware.

### 2D-OEIC Devices and Fabrics

To further take advantage of the spatial bandwidth available in the optical domain, integrated electronic circuits could be integrated with optical detectors (inputs) and modulators/microlasers (outputs). This mixture of the processing capabilities of electronics and the communications capabilities of optics will allow connection-intensive architectures with more complex nodes to be implemented. In addition, the gain provided by the electronic devices should allow high-speed operation of the nodes. In the simplest case, the 2D-OEICs, or "smart pixels" in this case, could be a large 2-D array of electronic nodes, such as (2,2,1), (2,2,2), or even (4,4,4) nodes. All the nodes in the 2-D array are electrically independent from each other, with the exception of a common ground and power supply. These "smart pixels" could also be developed to include the more complex circuitry necessary for self-routing nodes.

In general, 2D-OEICs need not be restricted to systems based on chip-to-chip interconnection. These structures could also be used to provide optical interconnection between MCMs or even PCBs. As an example, there could be 2D-OEICs—arrays of modulators, microlasers, and detectors—flip-chip-mounted on MCMs to provide the required MCM-to-MCM connectivity. These optical interconnects provide the advantage of lower on-chip power dissipation than their electrical counterparts when the distance between MCMs is greater than 1 mm and the bit rates are in excess of 100 Mb/s. A reduction of on-chip power dissipation should allow a greater gate density on the MCMs before thermal limit is reached. As an example, Fig. 15 illustrates a proposed 1024 x 1024 Clos network in which each of the three stages is composed of multiple electronic ICs mounted on an MCM. The three MCMs, each containing the hardware required for a single stage, would be connected with free-space interconnects. Note that there must be in excess of 4000 pin-outs per MCM!

### Future

Just as the telecommunications network has come to rely on optical fiber for transmission systems, so it will require the capabilities of photonics to solve the connectivity issues associated with future broadband hardware. The optical transparency will be required for busses and backplanes used in LANs, MANs, and frame-to-frame/board-to-board interconnection. On the other hand, as the ICs and MCMs of the future increase in gate density, so will the required number of pin-outs; hence the need for the spatial bandwidth of optics. Using this increased connectivity, new architectures

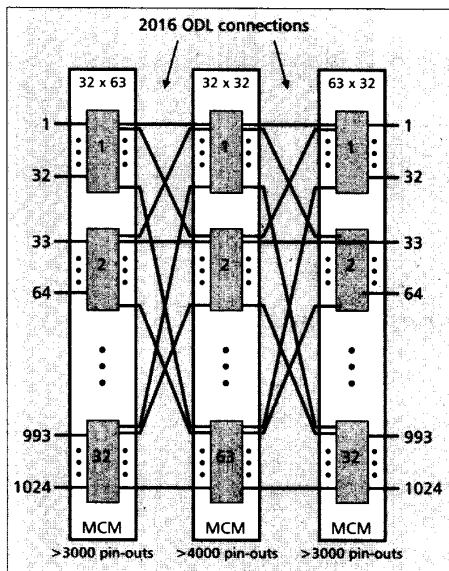

■ Figure 15. Clos network using MCMs and ODLs.

and systems will evolve that will meet the needs of processing terabits of information per second. Although it is unlikely that a purely photonic switch will be developed in the near future, it is certain that each succeeding generation of hardware will have more photonics embedded within it. There may not be pure photonic switching by the year 2000, but there certainly will be photonics in switching.

#### References

- [1] J. E. Berthold, "Broadband Electronic Switching," *OSA Proc. on Photonic Switching*, J. E. Midwinter and H. S. Hinton, eds., vol. 3, pp. 66-73, 1989.
- [2] H. S. Hinton, "Photonic Switching Fabrics," *IEEE Commun. Mag.*, vol. 28, no. 4, pp. 71-89, Apr. 1990.
- [3] M. E. Marhic, "Hierarchic and Combinatorial Star Couplers," *Opt. Lett.*, vol. 9, pp. 368-370, Aug. 1984.
- [4] R. V. Schmidt and R. C. Alferness, "Directional Coupler Switches, Modulators, and Filters Using Alternating Db Techniques," *IEEE Trans. on Circuits and Sys.*, vol. CAS-26, pp. 1099-1108, Dec. 1979.
- [5] R. R. Tummala and E. J. Rymaszewski, *Microelectronics Packaging Handbook*, New York: Van Nostrand Reinhold, 1989.
- [6] A. L. Lentine et al., "Symmetric Self-Electro-Optic Effect Device: Optical Set-Reset Latch, Differential Logic Gate, and Differential Modulator/Detector," *IEEE J. Quantum Elect.*, vol. QE-25, no. 8, pp. 1928-1936, Aug. 1989.
- [7] J. L. Jewell, M. C. Rushford, and H. M. Gibbs, "Use of a Single Non-linear Fabry-Perot Etalon as Optical Logic Gates," *App. Phys. Lett.*, vol. 44, no. 2, pp. 172-174, Jan. 15, 1984.
- [8] S. D. Smith, "Optical Bistability, Photonic Logic, and Optical Computation," *App. Optics*, vol. 25, no. 10, pp. 1550-1564, May 15, 1986.
- [9] G. W. Taylor, J. G. Simmons, A. Y. Cho, and R. S. Mand, "A New Double Heterostructure Optoelectronic Device Using Molecular Beam Epitaxy," *J. App. Phys.*, vol. 59, pp. 596-600, 1986.
- [10] K. Kasahara et al., "Double Heterostructure Optoelectronic Switch as a Dynamic Memory with Low Power Consumption," *App. Phys. Lett.*, vol. 52, pp. 679-681, 1988.

- [11] H. S. Hinton, "Architectural Considerations for Photonic Switching Networks," *J. Sel. Areas in Commun.*, vol. 6, pp. 1209-1226, Aug. 1988.
- [12] H. S. Hinton, "Photonic Switching Using Directional Couplers," *IEEE Commun. Mag.*, vol. 25, no. 5, pp. 16-26, May 1985.
- [13] K. Padmanabhan and A. N. Netravali, "Dilated Networks for Photonic Switching," *IEEE Trans. on Commun.*, vol. COM-35, no. 12, pp. 1357-1365, Dec. 1987.
- [14] T.-Y. Feng, "A Survey of Interconnection Networks," *IEEE Comp.*, pp. 12-27, Dec. 1981.
- [15] C.-T. Lea, "Bipartite Graph Design Principle for Photonic Switching Systems," *IEEE Trans. on Commun.*, vol. 38, no. 4, pp. 529-538, Apr. 1990.
- [16] G. W. Richards, U.S. Patent Nos. 4,993,016 and 4,991,168.
- [17] R. A. Thompson, R. V. Anderson, J. V. Camlet, and P. P. Giordano, "Experimental Modular Switching System with a Time-Multiplexed Photonic Center Stage," *OSA Proc. on Photonic Switching*, J. E. Midwinter and H. S. Hinton, eds., vol. 3, pp. 212-218, 1989.
- [18] H. Goto, K. Nagashima, and S. Suzuki, "Photonic Time-Division Switching Technology," *Photonic Switching: Proc. 1st Topical Mtg.*, T. K. Gustafson and P. W. Smith, eds., New York: Springer-Verlag, pp. 151-157, 1987.
- [19] S. V. Ramanan and H. F. Jordan, "Serial Array Shuffle-Exchange Architecture for Universal Permutation of Time-Slots," *Dig. Opt. Comp. II, SPIE*, vol. 1215, pp. 330-342, 1990.
- [20] J. P. Ofman, "A Universal Automation," *Trans. Moscow Math Soc.*, vol. 14, Providence, R.I.: Amer. Math Soc., pp. 200-215, 1967.
- [21] M. Skov, "Implementation of Physical and Media Access Protocols for High-Speed Networks," *IEEE Commun. Mag.*, pp. 45-53, June 1989.
- [22] P. R. Prucnal and P. A. Perrier, "A New Direction in Photonic Switching: A Collapsed-Network Space-Division Switching Architecture," *OSA Proc. on Photonic Switching*, J. E. Midwinter and H. S. Hinton, eds., vol. 3, pp. 212-218, 1989.
- [23] M. Fujiwara et al., "A Coherent Photonic Wavelength-Division Switching System for Broadband Networks," *Proc. 14th Euro. Conf. on Commun. (ECOC '88)*, Brighton, U.K., pp. 139-142, Sept. 11-15, 1988.
- [24] H. Kabrinski et al., "Demonstration of High Capacity in the LAMBDANET Architecture: A Multiwavelength Optical Network," *Elect. Lett.*, vol. 23, pp. 824-826, 1987.
- [25] I. P. Kaminow, P. P. Iannone, J. Stone, and L. W. Stulz, "FDM-FSK Star Network with a Tunable Optical Filter Demultiplexor," *Elect. Lett.*, vol. 23, pp. 1102-1103, 1987.
- [26] B. Glance et al., "Densely Spaced FDM Coherent Star Network with Optical Signals Confined to Equally Spaced Frequencies," *J. Lightwave Tech.*, vol. 6, no. 11, pp. 1770-1781, Nov. 1988.
- [27] M. S. Goodman et al., "Demonstration of Fast Wavelength Tuning for a High Performance Packet Switch," *Proc. 14th Euro. Conf. on Opt. Commun. (ECOC '88)*, Brighton, U.K., pp. 255-258, Sept. 11-15, 1988.
- [28] T. J. Cloonan and F. B. McCormick, "Photonic Switching Applications of 2-D and 3-D Crossover Networks Based on 2-Input, 2-Output Switching Nodes," *App. Optics*, vol. 30, no. 17, pp. 2309-2323, June 10, 1991.
- [29] T. J. Cloonan et al., "An All-Optical Implementation of a 3D Crossover Switching Network," *IEEE Photonics Tech. Lett.*, vol. 2, pp. 438-440, 1990.
- [30] J. L. Brubaker et al., "Optomechanics of a Free-Space Photonic Switch: The Components," *Optomechanics and Dimensional Stability, SPIE*, vol. 1533, pp. 88-96.
- [31] F. B. McCormick et al., "Optomechanics of a Free-Space Photonic Switch: The System," *Optomechanics and Dimensional Stability, SPIE*, vol. 1533, pp. 97-114.
- [32] T. J. Cloonan, G. W. Richards, F. B. McCormick, and A. L. Lentine, "Extended Generalized Shuffle Network Architectures for Free-Space Photonic Switching," *OSA Proc. on Photonic Switching*, H. S. Hinton and J. W. Goodman, eds., vol. 8, pp. 43-47, 1991.

#### Biography

H. SCOTT HINTON (M) received a B.S.E.E. in 1981 from Brigham Young University and an M.S.E.E. from Purdue University in 1982. In 1981, he joined AT&T Bell Laboratories, where he is currently Head of the Photonic Switching Department. He has been active in photonic switching systems research for the past eight years, and has published over 20 articles, co-edited 4 books, presented over 50 conference papers, taught three short courses, and has been awarded 12 patents.

•••••  
 There may not be pure photonic switching by the year 2000, but there certainly will be photonics in switching.