

Modeling carbon dynamics in an arid forest ecosystem

著者	Kawanishi Takuya, Egashira Yasuyuki, Abe Yukio, Kojima Toshinori
journal or publication title	Proceedings of EMEA 2005 in Kanazawa, 2015 International Symposium on Environmental Monitoring in East Asia -Remote Sensing and Forests-
page range	123-128
year	2005-11-28
URL	http://hdl.handle.net/2297/5954

Modeling Carbon Dynamics in an Arid Forest Ecosystem

Takuya KAWANISHI¹, Yasuyuki EGASHIRA², Yukio ABE³

Toshinori KOJIMA⁴ and Koichi YAMADA⁴

¹Graduate School of Natural Science and Technology, Kanazawa University,

Kakuma-machi, Kanazawa, 920-1192 Japan

²Department of Chemical Science and Engineering, Osaka University

1-3 Machikaneyama-cho, Toyonaka-shi, Osaka, 560-8531, Japan

³Graduate School of Life and Environmental Sciences, University of Tsukuba,

1-1-1 Tennodai, Tsukuba-shi Ibaraki-ken, 305-8577, Japan

⁴Department of Materials and Life Science, Seikei University,

3-1 Kichijoji-kitamachi 3-chome, Musashino-shi, Tokyo 180-8633, Japan

Faculty of Textile Science & Technology, Shinshu University,

*corresponding author: email: kawanisi@t.kanazawa-u.ac.jp

Key words: arid land afforestation, carbon dynamics, remote sensing, litter, soil

Abstract

A series of experiments have been carried out in Western Australia in order to develop the techniques for afforestation in arid lands. Remote sensing was used for evaluating the amount of biomass in the research area of 30 km x 50 km. We have developed models for growth of individual trees and also carbon dynamics in litter and soil. Now we need some models which connect the behavior of the individual tree to the dynamics of carbon in the forest scale ecosystems.

1. Introduction

Afforestation can be one of a few countermeasures for global warming. For effective sequestration of carbon dioxide, it is desirable to apply afforestation to large area. However, we do not want to consume lands that can potentially be used for future food production. Thus, afforestation in *arid* land is considered as a practical way for planting trees in large area, and a series of experiments are being carried out for developing and evaluating the techniques for arid land afforestation and reforestation, in Sturt Meadows near Leonora, Western Australia[1-5].

For estimating the potentials of several different afforestation techniques, we needed to evaluate the amount of biomass existing in the research area of 30 km x 50 km. By using remotely sensed data and with several ground truth efforts, we successfully estimated the amount of biomass in the area and also found that the amount of biomass can be correlated to the catchment area by a power law [3]. This suggests that there should be some topographical effects on the distribution of biomass, and that we should take this into account when we predict the amount of biomass.

We are developing models for estimating the effect of several arid land afforestation techniques, for this, attempts are made to connect the behavior of individual tree to the changes in the special distribution of biomass in the area.

2. Models

2.1 Structure of the model

We successfully have developed the individual tree growth model under the limited water availability, and also the litter and soil carbon dynamics model. Now we are integrating these two models. The next, rather challenging step is how we develop the model that will describe the

special distribution of the biomass. Here we only explain the concept of the litter and soil carbon dynamics model.

2.2 Carbon dynamics model in the litter and soil

In general, in forest ecosystems, litter and soil carbon play significant roles in carbon dynamics: not only that they retain as much as or more than carbon in plant bodies[6-8], but also the litter and soil carbon might become sources of carbon dioxide, if the trees were cut and not re-planted. Thus, carbon dynamics models for forest ecosystems usually incorporate litter and soil carbon dynamics[9-10].

Our findings in the project was that a significant amount of litter have seemed to flow out from the site, due to the flooding which occurs once in a year or every two years. Thus, we incorporate the physical removal of litter into the model.

Fig. 1 shows the structure of the model. The model consisted of three major compartments of carbon pools: plant body (WP), litter (WL) and soil (WS). Litter carbon was further divided into n sub-compartments according to their decomposition rates (WP_i , ($i=1, \dots, n$)).

Carbon flows between the compartments were as follows: NPP is put into plant body, and the plant body produces litter. Then, a part of the litter is removed physically by flooding water or winds, we represent this as run-off and subscript “run” is used for describing the phenomena. Another part of the litter is transformed into soil organic matter (humus), and the other part of the litter would be lost to respiration. As for soil carbon, carbon input was transformation from litter, and output is the respiration loss.

In this series of investigations, we set the carbon pool in the plant body a fixed value, and then the changes in carbon pools in litter fractions and soil were calculated. The annual litter production was assumed to be proportional to the amount of carbon in plant body and calculated as $k_{LF}WP$, where WP is the amount of carbon in the plant [kg m^{-2}] and k_{LF} is the rate constant [year^{-1}].

Annual litter production $k_{LF}WP$ then was divided into several parts according to their decomposition rates. We defined the mass ratio of the i -th fraction of the litter as x_i , thus, $x_i k_{LF}WP$ of carbon is put into the i -th sub-compartment of litter every year. i -th sub-compartment of the litter

decomposes (either lost via respiration or transformed into soil carbon) at the rate of $k_i WP_i$, and also lost via physical removal at the rate of $k_{run} WP_i$, where k_i and k_{run} are the first order rate constant [year^{-1}]: we assumed different decomposition rate constants but the same physical removal rate constant. Thus, the change of carbon in each litter fraction is described as follows.

$$\frac{dWL_i}{dt} = x_i k_{LF} WP - (k_{L,deg_i} + k_{run}) WL_i \quad (1)$$

$$\frac{dWL}{dt} = \sum_i \frac{dWL_i}{dt} \quad (2)$$

Annual physical loss of the litter via run-off, etc. is calculated as $k_{run} WL$, and was identical to the sum of $k_{run} WL_i$, and the total litter decomposition rate was calculated by Eq. (2).

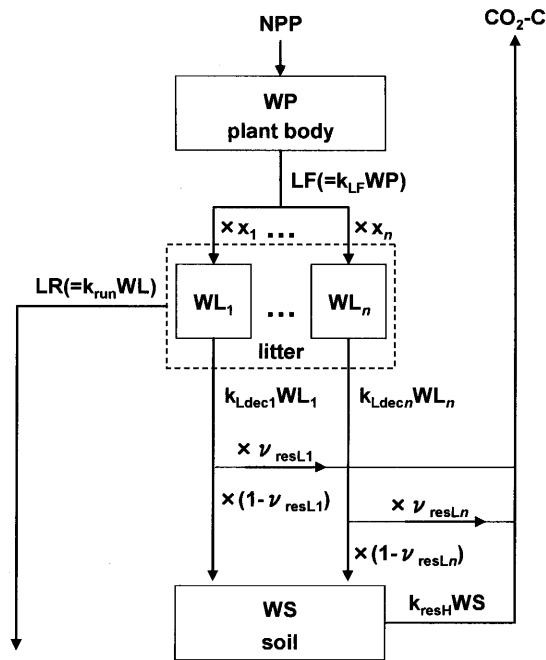

Fig. 1 Structure of Litter-soil carbon dynamics model.

In the decomposition of the litter, a part of the litter carbon was lost to respiration and the other part of the litter carbon was transformed to soil carbon. The ratio of respiration to transformation is different between the sub-compartments. We define the fraction of carbon lost to respiration of i -th sub-compartment of the litter carbon as v_{resLi} . Thus, the respiration loss of soil carbon was

$$\sum_i k_{L,deg_i} WL_i v_{resLi} \quad (3)$$

and carbon input to the soil carbon pool was

$$\sum_i k_{L,deg,i} WL_i (1 - v_{resLi}) \quad (4)$$

In the model, all the loss of carbon from soil was considered as respiration, and the rate of carbon loss was assumed to be first order.

$$\frac{dWS}{dt} = k_{resH} WS \quad (5)$$

3. Conclusion

Spatial distribution of biomass, including plant bodies and litter physically moved from original position, should be estimated if we want the ecosystem carbon storage change in arid land afforestation. For this, we may have to take into account the topographical effects, some kind of stochastic processes, etc.

References

- [1] Abe, Y., Kojima, T. and Yamada, K.; A large-scale afforestation in arid lands as countermeasures of CO₂, *J. Arid Land Studies*, **7**, 77-81 (1997).
- [2] Yamada, K., Kojima, T., Abe, Y., Williams, A. and Law, J.; Carbon sequestration in an arid environment near Leonora, Western Australia, *J. Arid Land Studies*, **9**, 143-151 (1999)
- [3] Abe, Y., Taniguchi, M., Suganuma, H., Saito, M., Kojima, T., Egashira, Y., Yamamoto, Y. and Yamada, K.; Comparative analysis between biomass and topographic features in an arid land, Western Australia, *J. Chem. Eng. Japan.*, **36**, 376-382 (2003)
- [4] Egashira, Y., Tomii, D., Ueyama, K., Takahashi, N., Kojima, T., Abe, Y., Saito, M. and Yamada Koichi; Development of integrated simulator of water transport and plant growth as an evaluation tool of arid land afforestation for CO₂ fixation, *J. Chem. Eng. Japan*, **36** (4) 383-390 (2003)
- [5] Takahashi, N., Tahara, K., Utsugi, H., Kojima, T., Egashira, Y., Abe, Y., Saito, M. and Yamada,

- K.; Water use efficiency of *Eucalyptus camaldulensis* growing in arid regions in Western Australia, **36**, 391-400, 2003.
- [6] Schlesinger, W. H.; Carbon balance in terrestrial detritus. *Ann. Rev. Ecol. Syst.*, **8**, 51-81 (1977)
- [7] Schlesinger, W. H.; Biogeochemistry. An analysis of global change, *Academic Press, San Diego*. (1997)
- [8] Houghton, R.A. and Skole, D.L; Carbon. Pp. In "The Earth as Transformed by Human Action", *Cambridge University Press, Cambridge*. 393-408 (1990).
- [9] Paul, K., Polglase, P., Bauhus, J., Raison, J. and Khanna, P.; Modelling change in litter and soil carbon following afforestation or reforestation: Calibration of the FullCAM 'beta' model, National Carbon Accounting System Technical Report No. 40, Australian Government (2003).
- [10] Moorhead, D.L. and Reynolds, J.F.; A general model of litterdecomposition in the northern Chihuahuan Desrt, *Ecol. Model.*, **56**, 197-219 (1991).