

Cooling system for the soft X-ray spectrometer onboard Astro-H

著者	Fujimoto Ryuichi, Mitsuda Kazuhisa, Yamasaki Noriko, Takei Yoh, Tsujimoto Masahiro, Sugita Hiroyuki, Sato Yoichi, Shinozaki Keisuke, Ohashi Takaya, Ishisaki Yoshitaka, Ezoe Yuichiro, Murakami Masahide, Kitamoto Shunji, Murakami Hiroshi, Tamagawa Toru, Kawaharada Madoka, Yamaguchi Hiroya, Sato Kosuke, Kanao Kenichi, Yoshida Seiji, DiPirro Mike, Shirron Peter, Sneiderman Gary, Kelley Richard L., Porter F. Scott, Kilbourne Caroline A., Crow John, Mattern Andrea, Kashani Ali, McCammon Dan, Herder Jan-Willem den
journal or publication title	Cryogenics
volume	50
number	9
page range	488-493
year	2010-01-01
URL	http://hdl.handle.net/2297/23933

doi: 10.1016/j.cryogenics.2010.02.004

Cooling system for the soft X-ray spectrometer onboard Astro-H

Ryuichi Fujimoto^{a,b}, Kazuhisa Mitsuda^b, Noriko Yamasaki^b, Yoh Takei^b, Masahiro Tsujimoto^b, Hiroyuki Sugita^c, Yoichi Sato^c, Keisuke Shinozaki^c, Takaya Ohashi^d, Yoshitaka Ishisaki^d, Yuichiro Ezoe^d, Masahide Murakami^e, Shunji Kitamoto^f, Hiroshi Murakami^f, Toru Tamagawa^g, Madoka Kawaharada^g, Hiroya Yamaguchi^g, Kosuke Sato^a, Kenichi Kanao^h, Seiji Yoshida^h, Mike DiPirroⁱ, Peter Shirronⁱ, Gary Sneidermanⁱ, Richard L. Kelleyⁱ, F. Scott Porterⁱ, Caroline A. Kilbourneⁱ, John Crowⁱ, Andrea Matternⁱ, Ali Kashani^{j,k}, Dan McCammon^l, Jan-Willem den Herder^m

^aFaculty of Mathematics and Physics, Kanazawa University, Kakuma-machi, Kanazawa, Ishikawa 920-1192, Japan

^bInstitute of Space and Astronautical Science, JAXA, 3-1-1 Yoshinodai, Sagami-hara, Kanagawa 229-8510, Japan

^cAerospace Research and Development Directorate, JAXA, 2-1-1 Sengen, Tsukuba, Ibaraki 305-8505, Japan

^dTokyo Metropolitan University, 1-1 Minami-Osawa, Hachioji, Tokyo 192-0397, Japan

^eInstitute of Engineering Mechanics and Systems, University of Tsukuba, 1-1-1 Tennodai, Tsukuba, Ibaraki 305-8573, Japan

^fRikkyo University, 3-34-1 Nishi-Ikebukuro, Toshima, Tokyo 171-8501, Japan

^gRIKEN, 2-1 Hirosawa, Wako, Saitama 351-0198, Japan

^hSumitomo Heavy Industries, Ltd., 5-2 Soubiraki-cho, Niihama, Ehime 792-8588, Japan

ⁱNASA Goddard Space Flight Center, Greenbelt, MD 20771, USA

^jNASA Ames Research Center, Moffett Field, CA 94035, USA

^kAtlas Scientific, 1367 Camino Robles Way, San Jose, CA 95120, USA

^lDepartment of Physics, University of Wisconsin, Madison, WI 53706, USA

^mSRON Netherlands Institute for Space Research, Sorbonnelaan 2, 3584 CA Utrecht, The Netherlands

Abstract

The Soft X-ray Spectrometer (SXS) is a cryogenic high resolution X-ray spectrometer onboard the X-ray astronomy satellite Astro-H which will be launched in 2014. The detector array is cooled down to 50 mK using an adiabatic demagnetization refrigerator (ADR). The cooling chain from the room temperature to the ADR heat-sink is composed of superfluid liquid He, a Joule-Thomson cryocooler, and double-stage Stirling cryocoolers. It is designed to keep 30 ℓ of liquid He for more than 5 years in the normal case, and longer than 3 years even if one of the cryocoolers fails. Cryogen-free operation is also possible in the normal case. It is fully redundant from the room temperature to the ADR heat-sink.

Key words: Space cryogenics (F), Adiabatic demagnetization (E), He II systems (E), Joule-Thomson coolers (E), Stirling (E)

1. Introduction

Astro-H, the 6th Japanese X-ray astronomy satellite [1], is being developed under extensive international collaboration between Japan and the US with European participation. It will

*Corresponding author. Address: Faculty of Mathematics and Physics, Kanazawa University, Kakuma-machi, Kanazawa, Ishikawa 920-1192, Japan. Tel.: +81-76-264-6072, Fax: +81-76-264-6055

Email address: fujimoto@se.kanazawa-u.ac.jp (Ryuichi Fujimoto)

be launched in 2014 from Tanegashima Space Center, using an H-IIA rocket. The Soft X-ray Spectrometer (SXS) onboard Astro-H is a high resolution spectrometer utilizing an X-ray microcalorimeter array [2]. Operated at 50 mK, it achieves a resolving power of 1000 or larger at 6 keV, more than one order of magnitude better than that of silicon detectors. With this performance, the SXS is expected to reveal merging of galaxy clusters or particle acceleration in the Universe. The telescope, the detector array, an adiabatic demagnetization refrigerator (ADR), an aperture cylinder and optical/infrared blocking filters, and their control electronics are developed by NASA, while the cooling system from the room temperature to the ADR heat-sink and the signal processing electronics are developed by JAXA.

In X-ray astronomy satellites, telescopes do not need to be cooled down. Only the cryogenic detector is kept at a low temperature. This means that a direct path of radiation from outside can be limited to a small aperture for focused X-rays. By using thin filters, background optical and infrared radiation can be significantly blocked. This makes a cooling system for X-ray satellites relatively small compared with that of infrared satellites. On the other hand, a cryogenic X-ray detector is usually only one of several payload instruments. It has to accommodate other warm instruments in a spacecraft, and hence, it is difficult to decouple the cooling system from the spacecraft. It also should be noted that, as the parasitic heat load becomes smaller, minor contributions ignored before could become crucial. Therefore, one must be very careful in the thermal design.

The X-Ray Spectrometer (XRS) onboard Suzaku (Astro-E2; launched in 2005) [3] was the first cryogenic X-ray detector in orbit [4]. It achieved 60 mK and energy resolution of 7 eV (FWHM) in orbit. However, there was a design problem. A small amount of the vented He gas from the He tank stayed inside the spacecraft and penetrated into the dewar guard vacuum, causing a thermal short and total loss of liquid He (LHe). The SXS is a successor of the Suzaku XRS, and will fulfill the science observations that the XRS was expected to perform with even better performance. One of the critical parts of the SXS is the cooling system. The design is based on the experience and lessons of the XRS and also makes the maximum use of the heritage of the XRS, Akari (Astro-F; launched in 2006) [5, 6], and SMILES [7, 8, 9], to satisfy the lifetime requirement of 3 years (goal: 5 years). As of June 2009, we are in the preliminary design phase.

In this paper, we describe the design of the SXS cooling system from room temperature to the ADR heat-sink as of June 2009.¹ Details of the ADR, cryocoolers, and He vent system are described elsewhere [10, 11, 12].

2. Requirements for the SXS cooling system

To satisfy the top level requirements, the SXS cooling system is required to keep the detector temperature at 50 mK with a temperature stability of $2 \mu\text{K}$ and with $>95\%$ efficiency for 3 years (and 5 years as a goal). An ADR is the only viable space-based cooling method that meets the temperature, stability, and recycle time requirements, and a double-stage ADR is selected as the last stage cooler [10].

The cooling chain from room temperature to the ADR heat-sink is required to keep its temperature at 1.8 K or less for 3 years or longer. The heat load of the ADR to the heat-sink is 0.2 mW on average. The detector assembly has JFETs operating at 130 K as readout circuits.

¹After this paper was written, we decided to adopt a ^4He JT cryocooler and another unit of an ADR instead of a ^3He JT cryocooler. This design change will be described elsewhere.

The primary heat-sink for the warm JFETs is the inner vapor-cooled shield (IVCS). The parasitic heat load from the 130 K JFETs to the ADR heat-sink strongly depends on the temperature of this heat-sink and is 0.3 mW if the IVCS temperature is 26–28 K. Thus, total heat load of the ADR and the detector assembly to the ADR heat-sink is 0.5 mW in the normal case.

From a reliability point of view, redundancy in case of failure of a single cryocooler is required for this cooling chain.

3. Design concept

The design concept of the SXS cooling system is given in Figs. 1 and 2. The cooling chain from room temperature to the ADR heat-sink is composed of superfluid liquid ^4He , a ^3He Joule-Thomson (JT) cryocooler, and double-stage Stirling cryocoolers (hereafter 2ST).

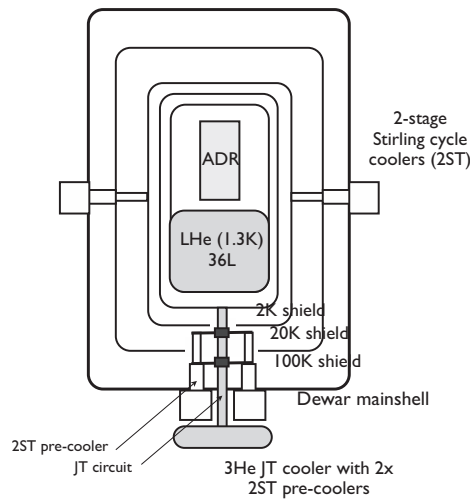

Figure 1: Design concept of the SXS cooling system.

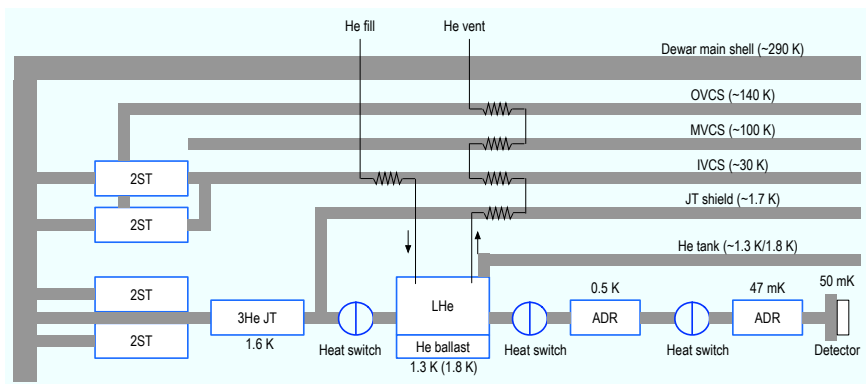

Figure 2: Conceptual thermal diagram of the SXS cooling system.

The starting point of the SXS cooling system design was that of the XRS. The XRS cooling system used LHe as a heat-sink for the ADR. Its goal was to limit the heat load to less than 1 mW such that 30 ℓ of LHe would last 2–3 years. For that purpose, it adopted solid neon as a second guard cryogen, and a single-stage Stirling cooler was used to cool the outermost vapor-cooled shield [13]. This provided a stable 17 K interface temperature and a clean (i.e., no microphonics) environment for the He tank and the detector. Although LHe had evaporated one month after the launch due to a design problem (location of the He vent), initial data suggested very good thermal performance as a cooling system [4]. However, we also found that using two cryogenes made the cooling system complicated, and ground operations hard to manage and risky.

Based on the XRS experience and lessons, we considered adopting cryocoolers for a more robust cooling system instead of cryogenes for the SXS. The first change is to replace the solid neon (17 K) with a 20 K-class cryocooler with a cooling power of 200 mW. This has already been demonstrated in orbit, by 2ST coolers on Akari [6]. According to thermal analysis, if we have four units of 2ST to cool the shield, the LHe lifetime is longer than 3 years in the normal case, and is still about 2 years even if one of the 2ST fails.

As the second change, we investigated adopting a 1–2 K-class cryocooler to further suppress the parasitic heat load to LHe. A likely candidate is the ^3He JT cryocooler being developed for SPICA [14, 15], which has a cooling power of 10 mW at 1.7 K. Currently, a ^4He JT cryocooler has been developed as a flight model for the SMILES instrument onboard the International Space Station and is scheduled to operate in orbit beginning in 2009 [9]. Development of the ^3He JT cryocooler is, however, at the breadboard/engineering model level and is not mature yet to replace the LHe completely. In addition, this cryocooler needs LHe for initial cooling or it takes a long time (>50 days) to cool down from room temperature. Therefore, we use it to reduce the parasitic heat load to the He tank. The design and present development status of the cryocoolers are described by Sato et al. in detail [11].

One of the concerns for the cryocoolers is the reliability of moving parts. In addition to the design improvements of the cryocoolers compared to Akari [11], we thought it essential to design the cooling system to be redundant for a failure of one cryocooler. We use two sets of 2ST to cool 20 K/100 K shields. A precooler for the JT cryocooler, which is composed of another pair of 2ST, is also doubled. They are operated with 50% power (50 W input) in the normal case. The JT circuit is not redundant, because heat load to the 2 K shield through the JT circuit is rather small even if it does not operate. With this design, LHe can be held for more than 5 years in the normal case and 3 years even if one of the cryocoolers fails as described in section 6. An advantage of this solution is that the JT cryocooler works as a functional redundancy for LHe (see section 7). Even if LHe is lost due to unexpected reasons like Suzaku XRS, the cooling system can be operated with the JT cryocooler. As a result, the cooling system is redundant down to the ADR heat-sink.

4. Mechanical and thermal design

In this section, we describe the design of the SXS dewar and the cooling system. Fig. 3 shows a cross sectional view of the SXS dewar. The detector array is cooled down to 50 mK using a double-stage ADR [10], with either LHe (~ 1.3 K) or the JT cryocooler (~ 1.8 K) providing the heat-sink for the ADR. The He tank is shielded by a JT shield, which is cooled with a JT cryocooler. There are three vapor-cooled shields (VCS); IVCS (inner VCS), MVCS (middle VCS), and OVCS (outer VCS). The IVCS and the OVCS are cooled by two units of 2ST shield coolers. The IVCS works as a mechanical support for the He tank. The IVCS, in turn, is suspended from

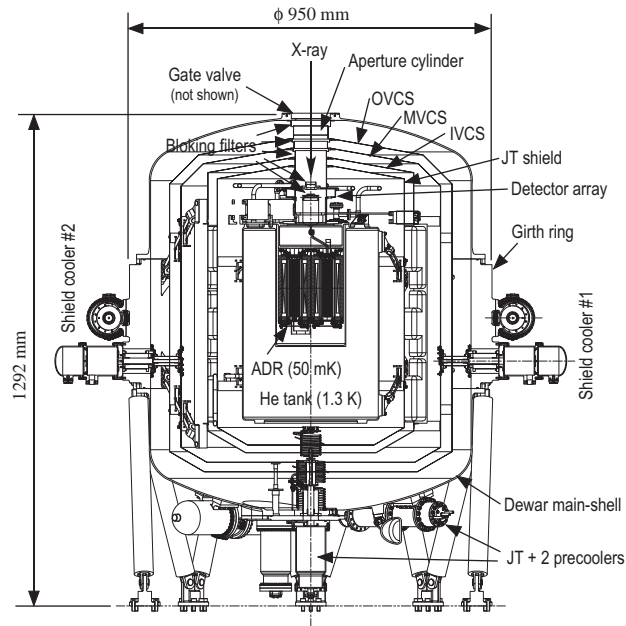

Figure 3: Cross section of the SXS dewar.

the dewar main-shell. The two 2ST shield coolers are attached to the girth ring of the dewar while the JT system is attached to the aft dome of the dewar. The JT system is composed of a JT circuit, three JT compressors, and two 2ST precoolers. The total mass of the dewar, not including the reflector described below and vent pipes described in section 5, is about 250 kg.

The nominal heat dissipation at the cryocoolers is 295 W ($50 \text{ W} \times 2$ at the shield coolers, $50 \text{ W} \times 2$ at the precoolers, and 95 W at the JT compressors), and about 460 W if all the cryocooler drive electronics are included. To achieve the thermal performance of the cooling system, the average external dewar surface temperature must be kept below 290 K. Moreover, all the cryocoolers must be operated below 30°C . On the other hand, all the JT compressors must be kept above -40°C , even if they are not operating. To satisfy these requirements, the main-shell surface is used as a radiator in addition to two dedicated radiator panels on the satellite ($2.1 \text{ m} \times 0.94 \text{ m}$). Note that the dewar is located inside the spacecraft structure, and only a part of the dewar surface is exposed to space. To use the dewar surface as a radiator efficiently, the dewar has a reflector around it where the dewar surface is not exposed to space, as shown in Fig. 4. Since the heat is generated only at the cryocooler locations, additional thermal paths (aluminum conductors and heat pipes) will be mounted on the dewar surface to spread the heat from the cryocoolers to the dewar surface.

5. He vent system

Figure 5 shows a schematic view of the plumbing and the valves of the dewar. The He tank is connected to the outside of the dewar through the He fill line and the He vent line. The dewar main-shell has vent valves to evacuate the guard vacuum and a gate valve for X-ray observations.

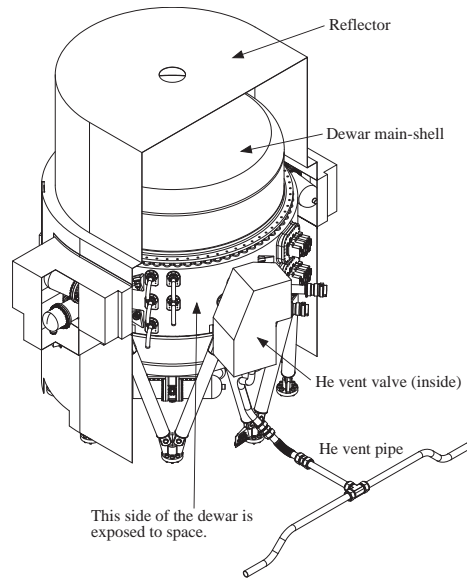

Figure 4: Schematic drawing of the reflector and the He vent pipe.

In orbit, superfluid LHe has to be confined in the He tank without gravity. For that purpose, a porous plug phase separator is used. At steady state, the He flow rate is extremely low ($\sim 25 \mu\text{g s}^{-1}$), and it is critical to suppress film-flow loss from the porous plug. For that purpose, a heat exchanger and a knife-edge device are used, to evaporate the film and cool the He tank by this evaporation [16]. Its design and development status are described by Ishikawa et al. in detail [12]. Just after the launch, the LHe temperature is higher than that of equilibrium. How much higher depends on the hold time after the LHe top-off operations without full cryocooler operations. In the worst case it could become 1.8–2.0 K and we need a flow rate of a few mg s^{-1} after we open the He vent valve to immediately begin cooling the LHe. Although calculations show that a single porous plug would accommodate this large flow, our baseline design has another porous plug optimized for initial large flow rate as a contingency, in addition to the nominal one. It is shut off using an electrically-driven cryo valve once the flow rate becomes small. A similar vent system was adopted by Akari and was demonstrated in orbit [6].

To keep 30 ℓ of LHe for more than 3 years, heat conduction due to residual He gas in the guard vacuum must be $\ll 1$ mW. This means that the He gas pressure must be $< 10^{-7}$ Pa. Even a small amount of He gas would violate this condition. Therefore, vented He gas must be completely kept away from the dewar and the spacecraft. Since the SXS dewar is not well exposed to space, we need an explicit vent path to ensure venting. This is shown in Fig. 4 as a He vent pipe. There are two exits in opposite directions in order to cancel momenta of the vented gas, although normally the flow is small and would not affect the spacecraft attitude and orbit control. A similar vent pipe is attached to the main-shell vent valve, and is routed to the other side of the spacecraft. Estimation of the backflow rate is underway by numerical simulation. In addition to these vent pipes, we are investigating sealing the main-shell guard vacuum from the outside of the dewar even in orbit, to completely prevent He gas from penetrating into it.

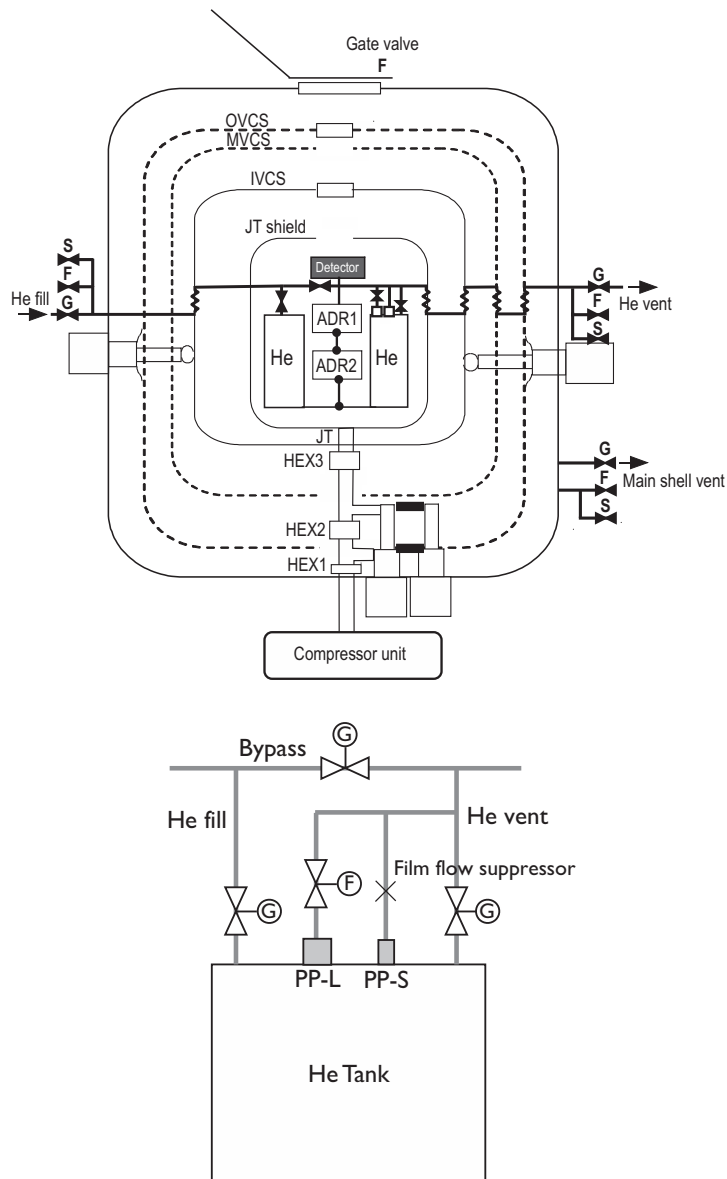

Figure 5: (Top) Schematic diagram of the plumbing and the valves. F, G, S are flight valves, valves for ground use, and safety valves, respectively. (Bottom) Schematic diagram of electrically-driven cryovalves and porous plugs (PP-L and PP-S) used to control the He flow.

6. Expected He lifetime in normal and cryocooler failure cases

We performed thermal analyses for the normal and failure cases. Failure of one cryocooler is considered, i.e., one shield cooler, the JT cryocooler, and one precooler of the JT cryocooler. The expected heat load to the He tank and lifetime of 30 ℓ of LHe are summarized in Table 1 for each case. In the normal case, the LHe lifetime can be extended to longer than 5 years and the goal is satisfied, while in all the failure cases, the lifetime is still longer than the requirement (3 years). Note that if the JT cryocooler fails, we have to operate two shield coolers with full power ($90 \text{ W} \times 2$) to lower the IVCS temperature ($\sim 20 \text{ K}$) and reduce the heat load to the He tank. If one precooler fails, the precooler tip temperature is not low enough to operate the JT cryocooler, and hence, the JT cryocooler does not work anymore. Therefore, we have to operate two shield coolers with full power in this case, too.

Table 1: Expected heat load and LHe lifetime in the normal case, failures of 1 shield cooler (SC), JT, and 1 precooler (PC).

Case	Cooler power (W)			Heat load to He tank (mW)	LHe lifetime (years)
	SC	PC	JT		
Normal	50×2	50×2	90	0.53	5.7
1 SC failure	90×1	50×2	90	0.83	3.6
JT failure	90×2	50×2	0	0.96	3.1
1 PC failure	90×2	90×1	0	0.99	3.0

7. Cryogen-free operation

The expected heat load to the JT cryocooler is about 5.2 mW in the normal case. This becomes 7.9 mW even if there is no LHe, which is still within the specification of the JT (10 mW cooling power at 1.7 K). This means that a cryogen-free operation is potentially possible in the normal case. This is very important from the reliability point of view, because it provides functional redundancy for a LHe failure like the XRS. Therefore, we investigated the possibility of a cryogen-free operation and implemented it into the cooling system design. Note that the ADR is designed assuming a worst case of 1.8 K as a boundary condition [10].

Firstly, thermal conductance between the He tank and the JT shield must be large enough so that the JT cryocooler can pump up heat from the He tank, the ADR, and the detector. However, it must be small when LHe exists and the He tank temperature is 1.3 K. This is solved by using a gas-gap heat-switch between the He tank and the JT shield. A gas-gap heat-switch controls its thermal conductance (on/off) using a getter and He gas [17]. When the getter is cold, it adsorbs He gas and opens the switch. When it is warmed, it releases gas to close the switch. In our system, this heat-switch is off (=heater off) when LHe exists, while it is turned on after the LHe runs out. A likely failure mode is that the switch remains off due to a He gas leak. In this case, there is no impact on the LHe lifetime, so long as the off-conductance is small enough. If the switch fails in the on-position, e.g., mechanical short during launch, the LHe lifetime becomes shorter than ~ 1 year. But this failure mode is very unlikely. Therefore, we conclude that the risk of having this heat-switch is very small, while it is essential after the LHe runs out.

Secondly, the heat load from the ADR during recycle (~ 10 J) must be kept below the cooling power of the JT cryocooler. The average heat load of the ADR is small, but most of the heat dissipation occurs during recycle, which could exceed the cooling power of the JT cryocooler. A possible solution is to have a thermal ballast, a sealed container of He gas and liquid which would undergo a phase transition in the temperature range of operation, to level the heat load that the ADR dumps during recycle. The baseline design is 4 g of He in a 4 ℓ volume tank. The need for the thermal ballast tank is under investigation, and will be decided based on the results of thermal analyses and thermal performance tests of the engineering model of the JT cryocooler.

If the cryocooler power is not available for a long time due to, for example, a spacecraft power crisis, LHe could be lost and the He tank temperature could become high. In the worst case, we have to start cooling down from room temperature. According to a transient analysis, it is possible to cool down the system from the room temperature with the cryocoolers alone, although it takes about 50 days. This will be experimentally demonstrated using an engineering model (EM) dewar.

8. Conclusion and future prospects

The preliminary design of the SXS cooling system from the room temperature to the ADR heat-sink is described. It is similar to that of the Suzaku XRS, but 2ST cryocoolers and a JT cryocooler are used instead of solid neon. Two 2ST units are used as shield coolers. A ^3He JT system, where two 2ST are used as precoolers, is adopted to cool the JT shield, to suppress parasitic heat load to the He tank. Each 2ST cryocooler is operated with 50% power (50 W input) in the normal case for redundancy. Heat dissipated at the cryocoolers (295 W in the normal case) is radiated from the dewar surface in addition to two dedicated radiator panels for the SXS, so that the average main-shell temperature is kept below 290 K. The lifetime achieved by this cooling system for 30 liters of LHe is 5.7 years in the normal case, and is still longer than 3 years even if one of the cryocoolers fails. This system works even if LHe is lost, i.e., cryogen-free operation is possible. For that purpose, a heat-switch is implemented between the He tank and the JT shield. A thermal ballast is under investigation to level the heat load of the ADR during recycle.

The He vent system is also described. In addition to a porous plug and film flow suppressor similar to the XRS, we plan to implement another porous plug optimized for large flow rate just after the launch. The SXS dewar has explicit vent pipes attached to the He vent valve and the main-shell vent valve, to ensure the vented He gas does not come back to the dewar and the spacecraft.

Although the cooling system is redundant for a failure of one cryocooler, reliability of the cryocoolers is essential. Performance tests and a lifetime test using the engineering model of 2ST and JT, which have just started, are very critical to finalize the design. Once the design is completed, we will start fabricating a full EM dewar with an ADR and a detector array in it. Tests using the EM dewar are planned in 2011, to verify the mechanical and thermal design as well as to confirm the scientific performance including susceptibility to cryocooler microphonics.

Acknowledgements

The authors are grateful to all the members of the Astro-H SXS team. RF acknowledges support by KAKENHI No. 19047001.

References

- [1] Takahashi T, et al. The NeXT Mission. SPIE 2008;7011:70110O
- [2] Mitsuda K, et al. The x-ray microcalorimeter on the NeXT mission. SPIE 2008;7011:70112K
- [3] Mitsuda K, et al. The X-Ray Observatory Suzaku. Publications of the Astronomical Society of Japan 2007;59(SP1):S1–S8
- [4] Kelley RL, et al. The Suzaku High Resolution X-Ray Spectrometer. Publications of the Astronomical Society of Japan 2007;59(SP1):S77–S112
- [5] Murakami H, et al. The Infrared Astronomical Mission AKARI. Publications of the Astronomical Society of Japan 2007;59(SP2):S369–S376
- [6] Nakagawa T, et al. Flight Performance of the AKARI Cryogenic System. Publications of the Astronomical Society of Japan 2007;59(SP2):S377–S387
- [7] Seta M, et al. Submillimeter-Wave SIS Receiver System for JEM/SMILES. Advances in Space Research 2000;26(6):1021–1024
- [8] Narasaki K, et al. Development of cryogenic system for SMILES. Advances in Cryogenic Engineering 2004;49B:1785–1794
- [9] Otsuka K, et al. Test results after refurbish of cryogenic systems for SMILES. Cryogenics 2010, in press
- [10] Shirron P, et al. ADR design for the soft X-ray spectrometer (SXS) instrument on the Astro-H mission. Cryogenics 2010, in press
- [11] Sato Y, et al. Development of mechanical cryocoolers for Astro-H/SXS. Cryogenics 2010, in press
- [12] Ishikawa K, et al. Porous plug and superfluid helium film flow suppressor for the soft X-ray spectrometer onboard Astro-H. Cryogenics 2010, in press
- [13] Fujimoto R, et al. Neon dewar for the X-ray spectrometer onboard Suzaku. NIMA 2006;559(2):648–650
- [14] Nakagawa T, Murakami H. Mid- and far-infrared astronomy mission SPICA. Advances in Space Research 2007;40:679–683
- [15] Sugita H, et al. Cryogenic infrared mission “JAXA/SPICA” with advanced cryocoolers. Cryogenics 2006;46:149–157
- [16] Shirron PJ, DiPirro MJ. Suppression of superfluid film flow in the XRS helium dewar. Advances in Cryogenic Engineering 1998;43:949–956
- [17] Nast T, Bell G, Barnes C. Development of Gas Gap Cryogenic Thermal Switch. Advances in Cryogenic Engineering 1982;27:1117–1124