

# Experimental Results for a Two-Material Passive di/dt Limiter

著者	Dawson F.P., Yamada Sotoshi, Iwahara Masayoshi
journal or publication title	IEEE Transactions on Maggetics
volume	31
number	6
page range	3734-3736
year	1995-11-01
URL	<a href="http://hdl.handle.net/2297/48333">http://hdl.handle.net/2297/48333</a>

doi: 10.1109/20.489754

EXPERIMENTAL RESULTS FOR A TWO-MATERIAL PASSIVE DI/Dt LIMITER

F.P. Dawson, S.Yamada\*, M. Iwahara\*

Department of Electrical and Computer Engineering  
University of Toronto, Toronto, Ontario, Canada, M5S-1A4

\*Department of Electrical and Computer Engineering  
Faculty of Engineering, Kanazawa University, Kanazawa 920, Japan

**Abstract:** The purpose of this paper is to experimentally verify the current limiting characteristics of a two material magnetic device consisting of a ferrite and permanent magnet material. A resonant pulsed excitation source and a 60 Hz ac source are used to test the characteristics of the device. The experiments confirm that there is a saturated and unsaturated inductance operating region and a current limiting and loss of current limiting kneepoint.

INTRODUCTION

Load growth and the attendant need for interconnection for reliability of supply has resulted in an increase in system fault levels. Solutions have to be devised to prevent the ratings of equipment such as circuit breakers and semiconductor devices from being exceeded. Current approaches to limiting fault currents are expensive, or are not reliable enough [1-6]. Recently, a passive type fault current limiter composed of permanent magnets and a low saturation flux density material was proposed [7,8]. This structure was found to offer poor transition characteristics between the normal and fault current level. The problem was resolved by proposing a structure with extended magnets [9]. Further improvements in the transition characteristics and cost reduction measures were facilitated by incorporating a third material with a saturation flux density higher than the permanent magnet flux density [10]. The purpose of this paper is to describe the experimental verification of the pulsed characteristics of a simple current limiter fabricated from two commercially available materials. Section 2 presents a simplified theoretical model for the characteristics of the prototype experimental device. Section 3 presents the experimental results obtained under the following test conditions; resonant pulsed excitation; sinusoidal voltage source excitation. Section 4 presents conclusions.

2. EXPERIMENTAL SETUP AND SIMPLIFIED ANALYSIS

Fig. 1 shows the device which is used to experimentally verify the characteristics of a simple passive unidirectional current limiter. Bipolar current limiting is achieved by connecting a second device in series with the first device where the coil on the second device is wrapped in the opposite direction. Two TDK HC71 ferrite E cores with a relative permeability of 3500 and a saturation flux density of .5T are separated by permanent magnet spacers with a thickness of 2 mm each. A five turn sensing coil is wrapped onto a bobbin 5.1 cm in length, followed by a 1000 turn excitation coil. The permanent magnets are made as thin as possible so as to obtain the smallest air gap and

thus the largest unsaturated inductance. The major items of practical interest in this device are shown in Fig. 2. They are the current kneepoint 1 ( $I_L$ ), the inductance below and above the kneepoint current 1, the current kneepoint 2 ( $I_{LL}$ ) beyond which the the device no longer limits the current, and the flux level at which demagnetization occurs. The demagnetization of the permanent magnet is designed to occur at a current which is larger than  $I_{LL}$  and the maximum fault current is designed to occur at a current which is less than  $I_{LL}$ .

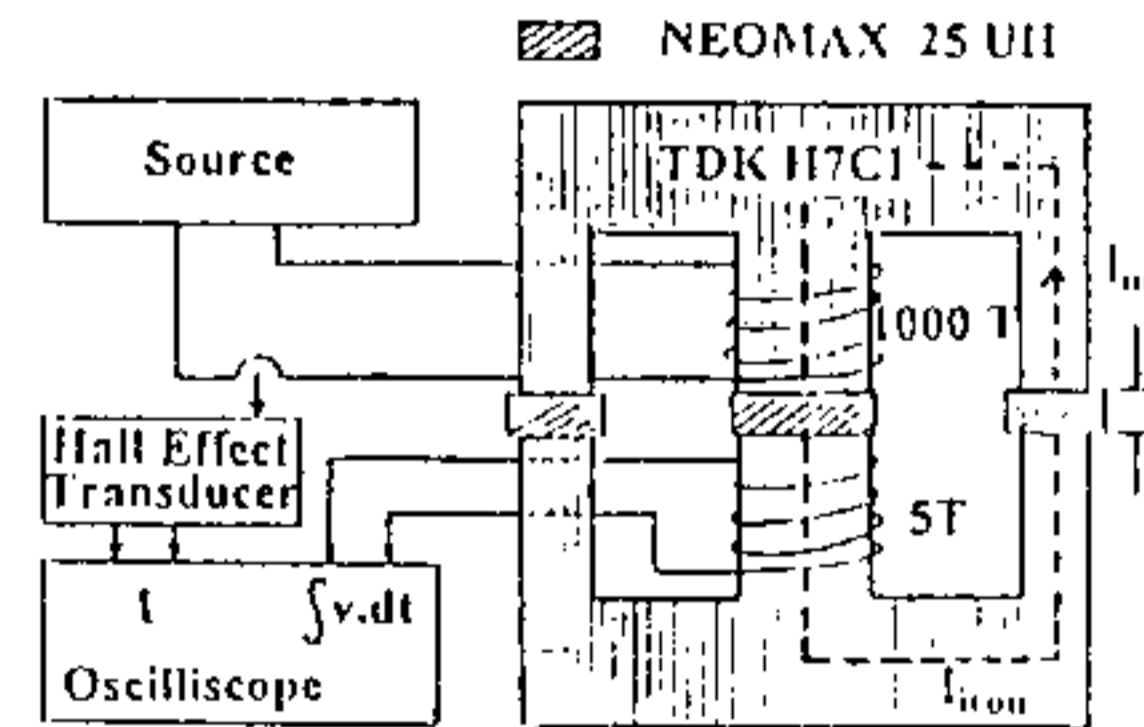

Fig.1 Prototype Fault Current Limiter

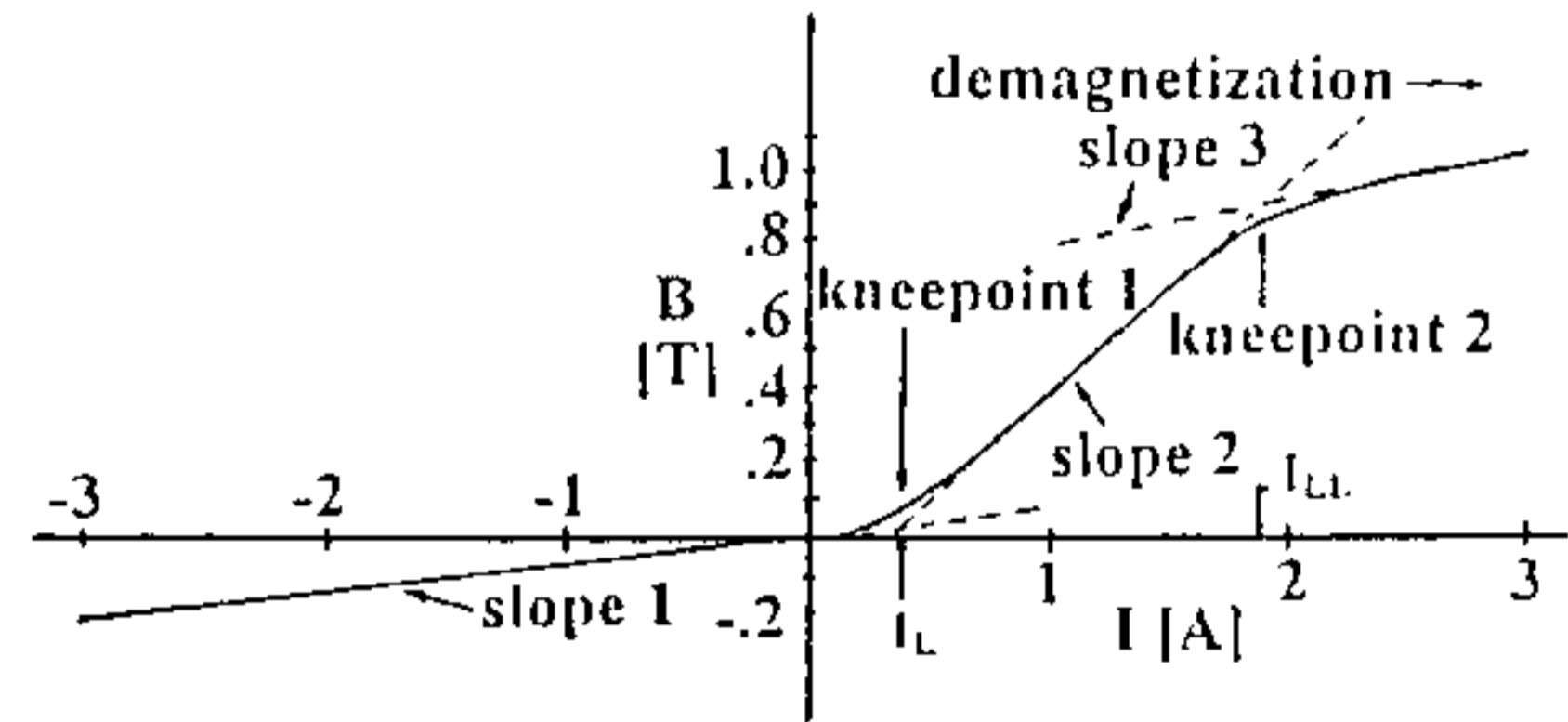

Fig. 2 Illustration of Performance Criteria

Simplified equations for the saturated inductance (slope 1 and slope 3), the unsaturated inductance (slope 2), and the approximate current Kneepoint at which limiting begins and at which limiting is suspended are given as follows.

Saturated Inductance Value

$$L_{sat} = \frac{\mu_o * N^2}{l_{bobbin}} * A_{bobbin} \tag{1}$$

Unsaturated Inductance Value

$$L_{\text{total}} = L_{\text{air}} * \frac{l_{\text{bobbin}}}{\frac{l_{\text{iron}}}{\mu_r} + 2 * l_m} \quad (2)$$

Current Kneepoint 1 (Limiting)

$$I_L = \frac{2 * B_r * l_m}{N * \mu_0} * \left[ 1 - \frac{B_r}{B_s} \right] \quad (3)$$

Current Kneepoint 2 (Loss of Limiting)

$$I_{LL} = I_L * \left[ \frac{1 + \frac{B_s}{B_r}}{1 - \frac{B_s}{B_r}} \right] \quad (4)$$

where  $l_{\text{iron}}$  is the mean path length of the ferrite core,  $l_m$  is the width of the permanent magnet shim,  $l_{\text{bobbin}}$  is the length of the coil assembly,  $B_r$  is the remanent flux density of the permanent magnet,  $B_s$  is the saturation flux density of the ferrite material,  $N$  is the number of turns and  $A_{\text{bobbin}}$  is the area of the coil.

**3. EXPERIMENTAL RESULTS**

Current measurements were made with a hall effect transducer. Flux versus current plots were obtained using an oscilloscope with a built in integrating function. The current limiter was connected by means of a switch to a 10,000  $\mu\text{F}$  capacitor charged to 9.5 volts. Fig. 3a shows the characteristic curves for the sensing coil voltage and the primary current versus time, after the switch is closed. Fig. 3b shows the same characteristic curve as Fig. 3a but with an initial capacitor voltage of 15 volts. Notice that the current limiting property for this particular level of excitation has been lost. Fig. 3c shows the volts-second integrals plotted versus the primary coil current for the conditions depicted in Fig. 3a and Fig. 3b. Hysteresis effects are not noticeable. This is to be expected since the

Pulse Characteristics

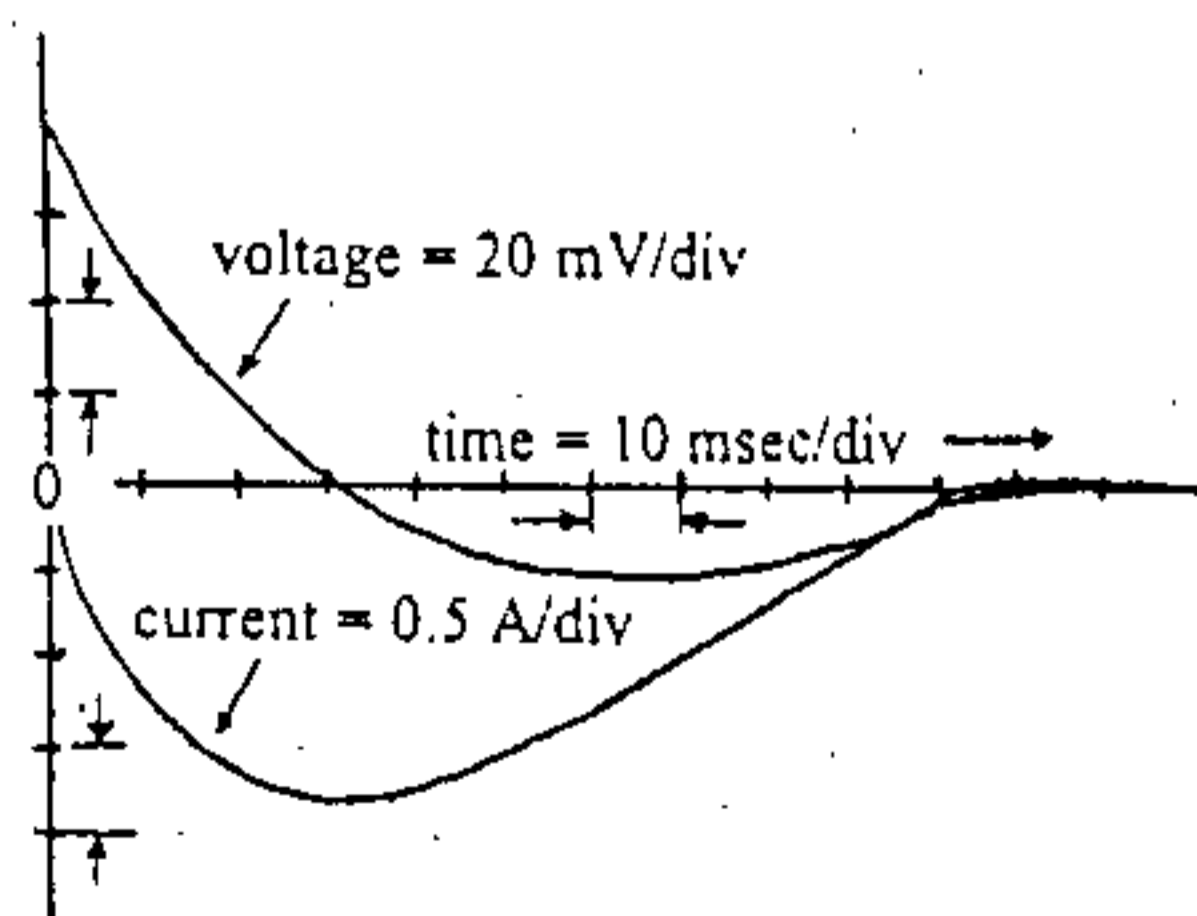

(a) induced voltage and current (initial voltage = 9V)

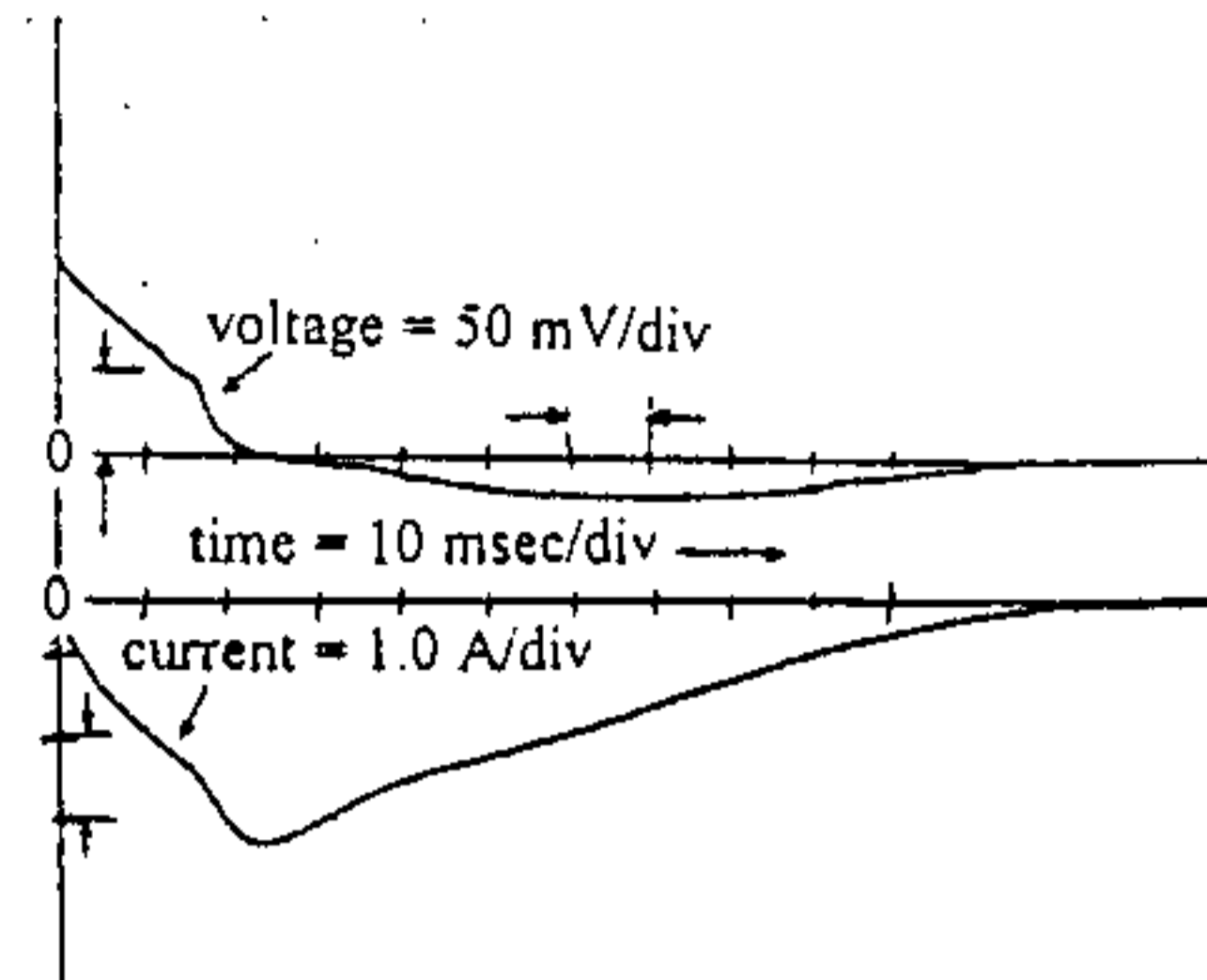

(b) induced voltage and current (initial voltage=15V)

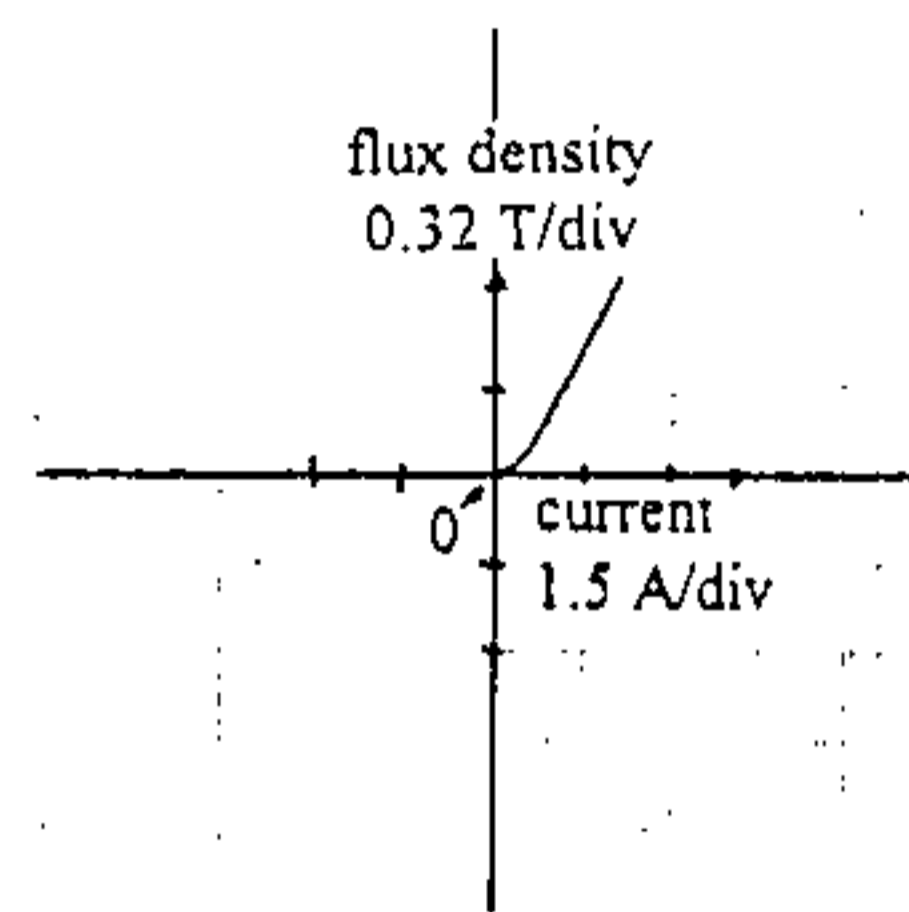

(c) volts-second integral versus current for (a) on left and (b) on right

**Fig. 3 Pulsed dc Time Domain and Flux versus Current Characteristics**

permanent magnet remains magnetized and thus a minor hysteresis loop with a small area is swept out below and above the permanent magnet recoil line.

AC Characteristics

Fig. 4a shows the characteristic curves for the sensing coil voltage and the primary coil current. Notice that the current limiting property is clearly seen for one value of current polarity but not the other. Fig. 4b shows the plot for the volts-second integral versus the primary coil current for the conditions depicted in Fig. 4a. Hysteresis effects are not noticeable. Table 1 shows the comparison between the calculated and experimentally observed design parameters.

Fig. 4a shows that the ratio of the clamped current and the unclamped current is approximately 2:1. This value is significantly less than the experimentally derived value of 12:1 corresponding to the ratio of the unsaturated and saturated inductance. The discrepancy between the two ratios is attributed to the large resistance of the 1000 turn coil. Consequently, the resistance rather than the saturated inductance influences the magnitude of the peak current during the positive half cycle.

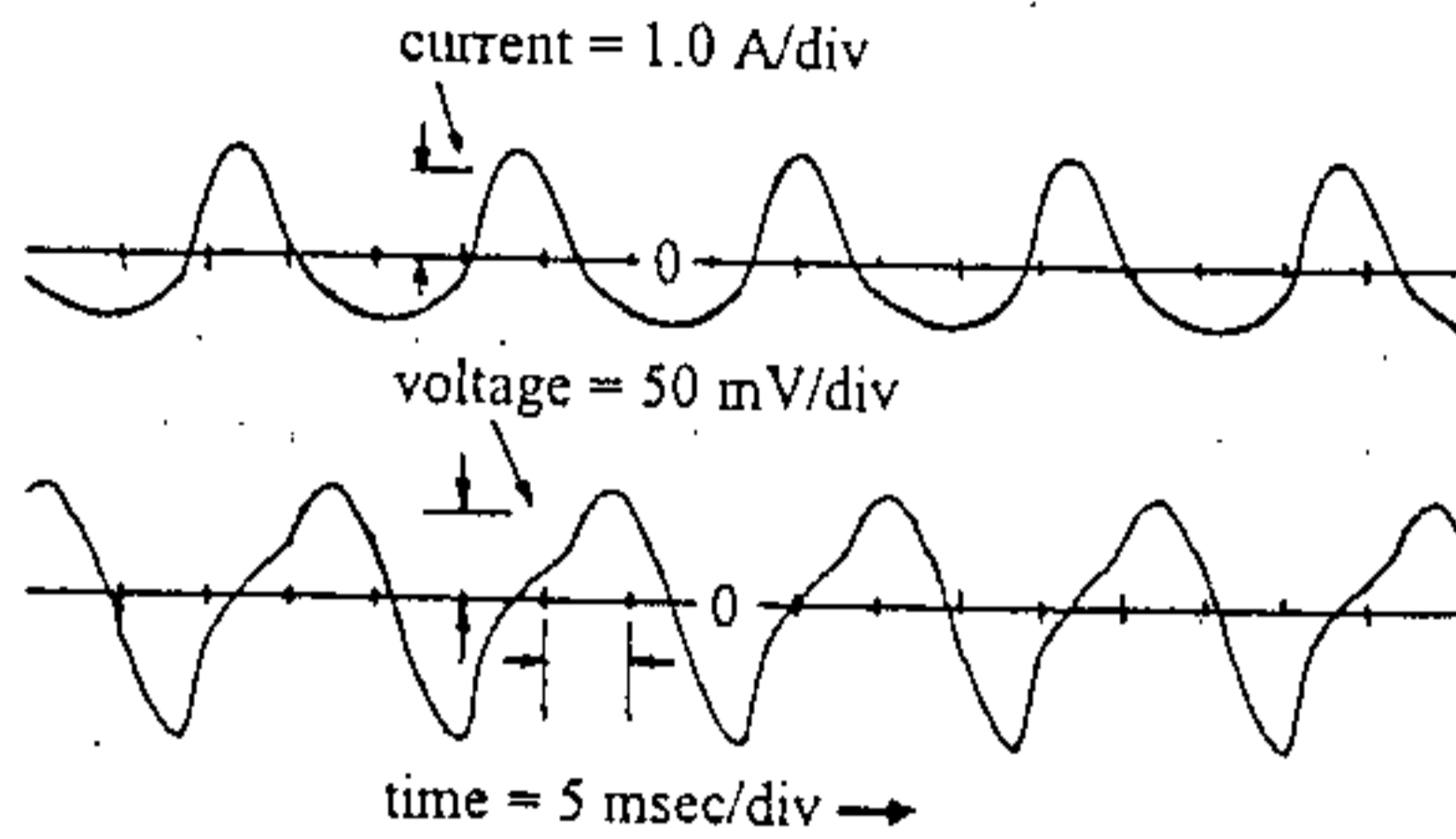

(a) induced voltage and current  
(ac voltage = 20 V<sub>rms</sub>)

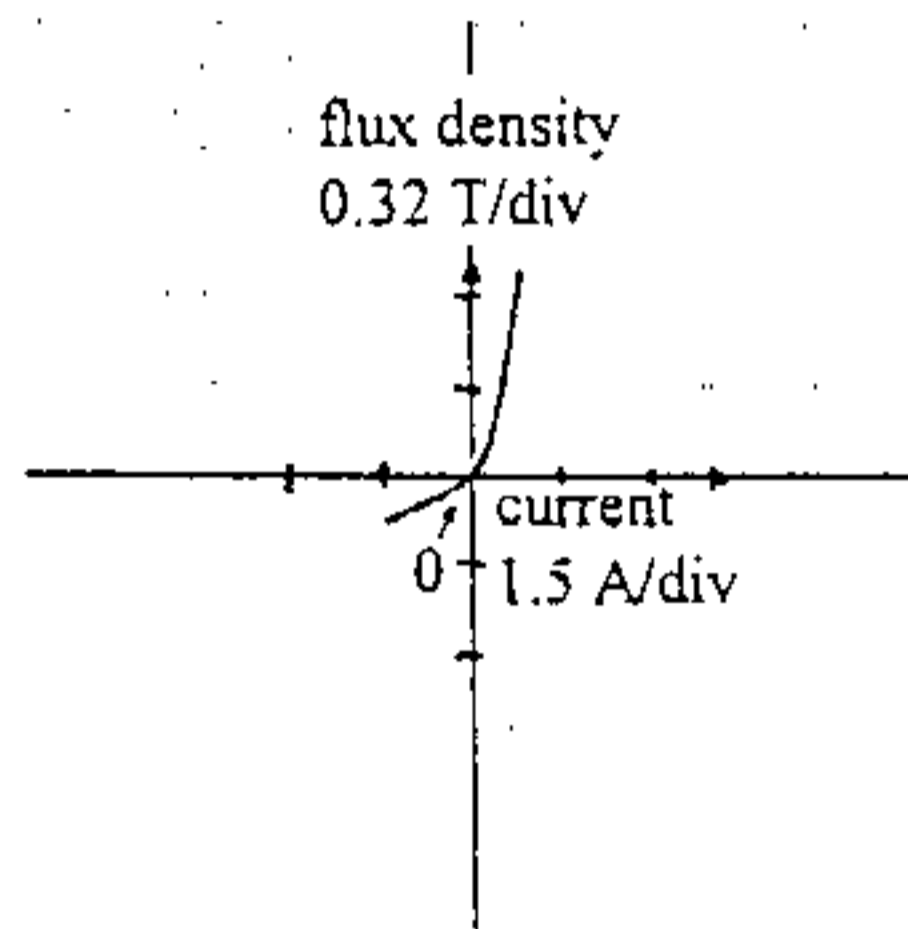

(b) volts-second integral versus current

Fig. 4 60 Hz time domain and Flux versus Current Characteristics

Table 1 Comparison of Experimental and Theoretical Performance Criteria

	analytical result	experimental result
slope 1	0.03 T/A	0.1 T/A
slope 2	0.31 T/A	0.4 T/A
slope 3	0.03 T/A	0.06 T/A
kneepoint 1	1.6 A	0.375 A
kneepoint 2	4.78 A	1.9 A

The analytical and experimental results are in qualitative agreement with each other. Deviations in the numerical results can be attributed to the nonuniform field distribution within the ferrite core material. This conjecture has already been shown to be true based on other results obtained from a finite element analysis [10].

## CONCLUSIONS

This paper has demonstrated that a composite magnetic structure consisting of permanent magnets and an iron core material of lower saturation flux density than the permanent magnet material can be exploited for use as a current limiting device. The experimental results are in qualitative agreement with the results obtained from the simplified expressions. Discrepancies between theory and experiment can be attributed to a non uniform field distribution within the ferrite core material. Improvements in the transition characteristics between the saturated and nonsaturated state can be facilitated by using a three material device. This device would be composed of a high saturation flux density material, a low saturation flux density material, and a permanent magnet. The remanent flux density of the permanent magnet material would lie between the values of the other two materials.

## REFERENCES

- [1] K. E. Gray, D. E. Fowler, "A Superconducting Fault-Current Limiter", *J. Appl. Phys.* 49(4), April 1978, pp 2546-2550
- [2] B. P. Raju, K. C. Parton, T. C. Bartram, "A Current Limiting Device Using Superconducting D.C. Bias: Applications and Prospects", *IEEE Trans. on Power Apparatus and Systems*, Vol. PAS-101, No. 9, September 1982, pp 3173-3177
- [3] P. Tixador et.al., "Hybrid Superconducting a.c. Fault Current Limiter: Principle and Previous Studies", *IEEE Trans. on Magnetics*, Vol. 28, No. 1, January 1992, pp 446-449
- [4] S. Shinizu, et.al., "Single-Line-to-Ground Fault Test of a 3-Phase Superconducting Fault Current Limiting Reactor", *IEEE Trans. on Magnetics*, Vol. 28, No. 1, January 1992, pp 442-445
- [5] D. Ito, et. al., "6.6kV/1.5kA-Class Superconducting Fault Current Limiter Development", *IEEE Trans. on Magnetics*, Vol. 28, No. 1, January 1992, pp 438-441
- [6] T. Ohnishi, et. al., *IEE of Japan Conference on Static Apparatus*, SA-91-67 (1991) (In Japanese)
- [7] S. Young, F.P. Dawson, "Application of a Passive dI/dt Limiter", *IAS Japan, Sapporo, Japan*, Aug. 27-29, 1991, pp E105-E107
- [8] S. Young, F.P. Dawson, A. Konrad, "Modeling of a Passive dI/dt Limiter", *IEEE Trans. on Magnetics*, Vol. 8, No.5, September 1992, pp. 3051-3053
- [9] S. Young, F.P. Dawson, A. Konrad, "An Extended Magnet in a Passive dI/dt Limiter", *Journal of Applied Physics*, 76(10), November 1994, pp.6874-6876
- [10] S. Young, F.P. Dawson, A. Konrad, "A Three-Material dI/dt Limiter", *Journal of Applied Physics*, 76(10), November 1994, pp. 6871-6873