

Eddy Current Testing Probe Composed of Planar Coils

著者	Yamada Sotoshi, Katou M., Iwahara Masayoshi, Dawson F.P.
journal or publication title	IEEE Transactions on Maggetics
volume	31
number	6
page range	3185-3187
year	1995-11-01
URL	http://hdl.handle.net/2297/48318

doi: 10.1109/20.490322

EDDY CURRENT TESTING PROBE COMPOSED OF PLANAR COILS

S. Yamada, M. Katou, M. Iwahara, *F. P. Dawson
 Laboratory of Magnetic Field Control and Applications
 Faculty of Engineering, Kanazawa University, Kanazawa 920, Japan
 *Department of Electrical and Computer Engineering
 University of Toronto, Toronto, Ontario, Canada, M5S-1A4

Abstract: This paper presents a new eddy-current probe composed of a micro-planar mesh coil and meander coil. The probe can be used to detect the existence and the size of cracks in metallic structures. Experimental results for the sensed output voltage of this device are presented. The output signal is shown to have a discrete nature. Also, the results show that the signal strength is weak and that an offset voltage exists. Improved probe characteristics are obtained by connecting two mesh coils in series, stacking the coils on top of each other and orienting the two coils 180° apart.

INTRODUCTION

Eddy current testing (ECT) is a nondestructive method used for locating cracks in metallic pipes and structural frames. Nondestructive testing (NDT) is increasingly being exploited to insure the ongoing safety of nuclear and chemical plants. There are currently two methods of ECT currently in use. One method relies on inducing eddy currents in a metallic structure under test [1]. The flux created by the the eddy currents changes the flux coupling the exciting coil and thus the coil's impedance. The impedance variation is then measured. Unfortunately, the output signal obtained using this method is very small. A second method uses an exciting coil to induce an eddy current within a test structure. A secondary coil measures the induced voltage generated by the eddy current's magnetic field. The magnitude of the induced voltage is higher than the value obtained using the impedance variation method, however, the high impedance of the coil results in an unacceptable noisy signal. This paper proposes the use of a dual planar micro coil structure to overcome the noise problem and to improve the measured signal strength [2]. The purpose of this paper is to experimentally demonstrate the improved characteristics of the new type of probe and to propose additional refinements which can further improve the quality of the measured output signal.

2. OPERATING PRINCIPLE OF PLANAR COIL TYPE ECT PROBE

Fig. 1(a) shows the layout diagram for the proposed ECT probe. The exciting coil is a meander type coil whereas the secondary coil is a mesh type coil with a pitch similar to that of the meander coil. The positioning of these two coils is shown in Fig. 1(b). Fig. 2(a) shows the equivalent 2-D magnetic model for the meander coil. The vertical component of magnetic field strength (H_n), measured along the dotted line denoted by 'Position of Testing Metal', is shown in Fig. 2(b). The distance 0 in Fig. 2(b) refers to the centre of the meander coil. Figs. 3(a)

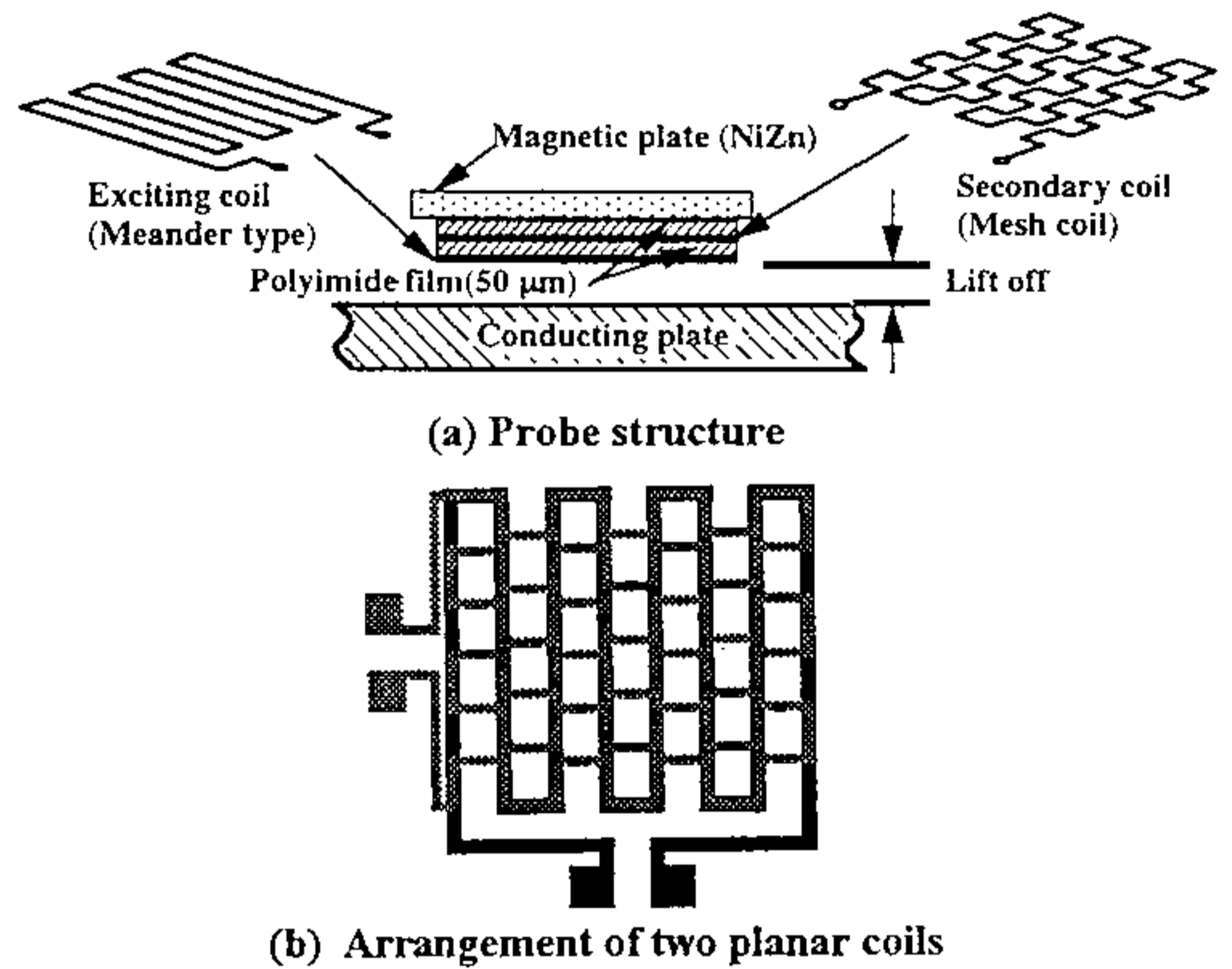
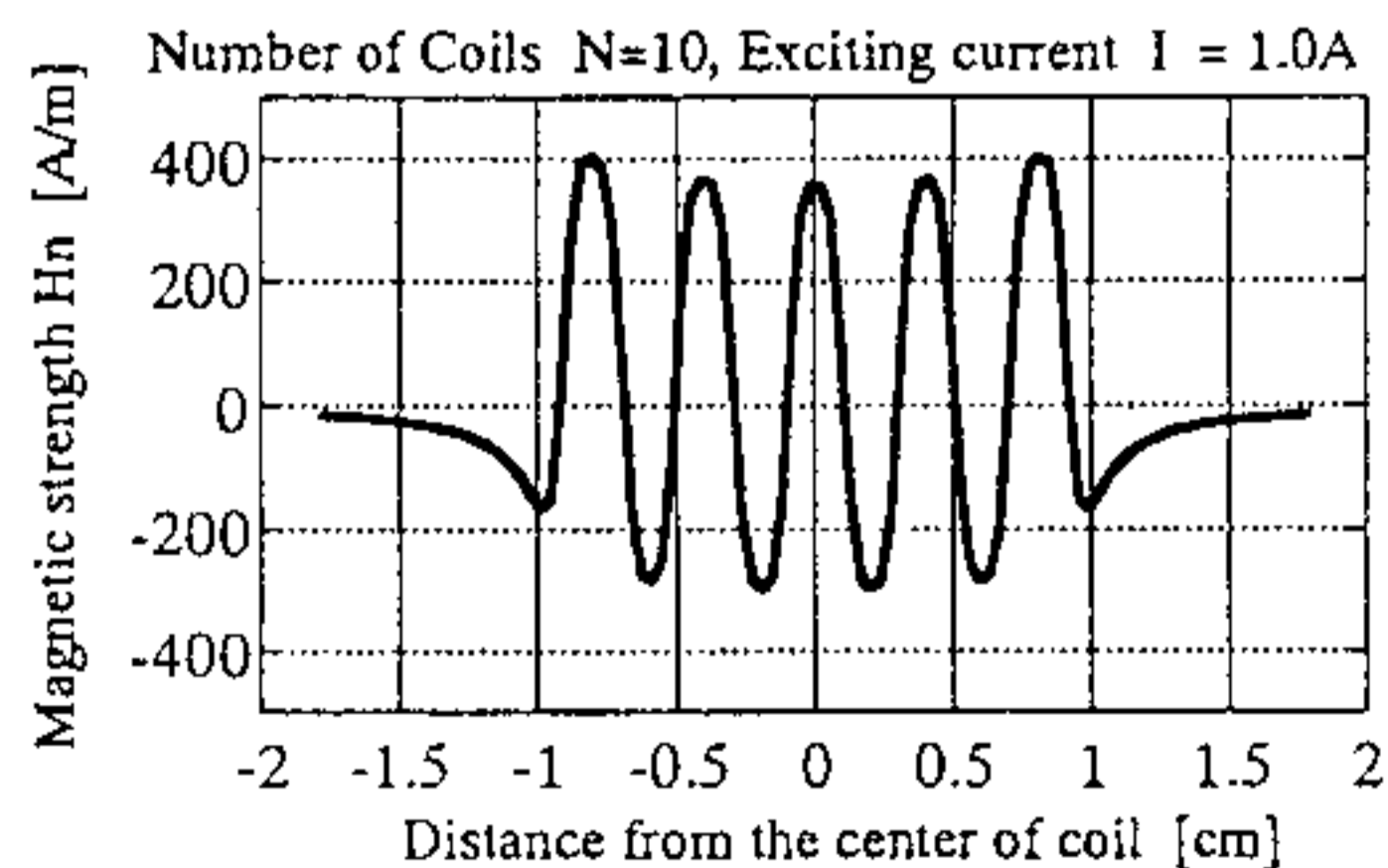
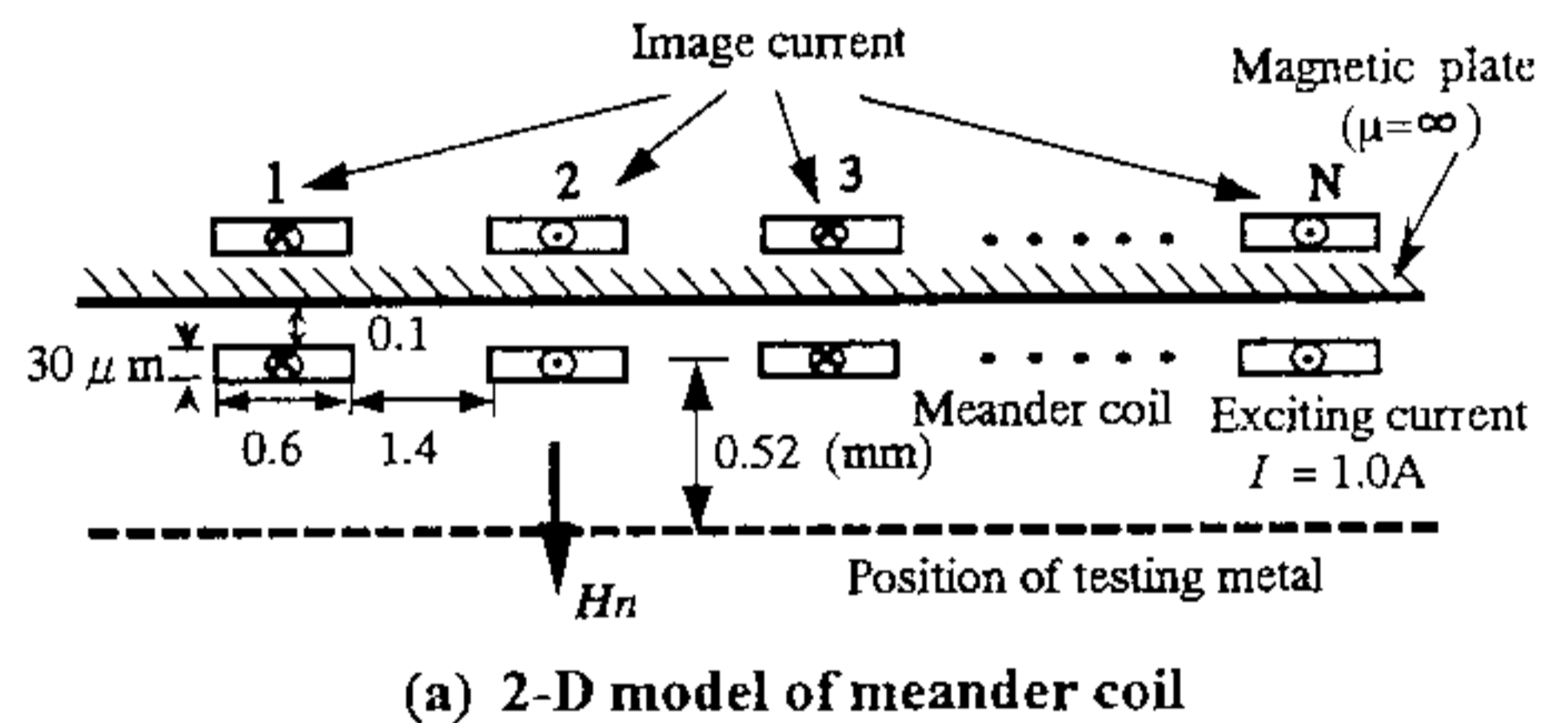

Fig.1 ECT Probe Composed of Two Kinds of Planar Coils



(b) Magnetic strength distribution with 0 distance coinciding with the centre of the meander coil

Fig. 2 Flux Density Distribution Generated by an Excited Meander Coil

and 3(b) show the pattern of eddy currents and flux which will be induced in a piece of metal not having and having a crack respectively. The mechanism by which a net variance in flux is produced is shown in Fig. 3c. The cross section of the mesh coil is represented by the shaded gray areas in Fig. 3(d). Only the flux variance, as shown in Fig. 3(c), is sensed.

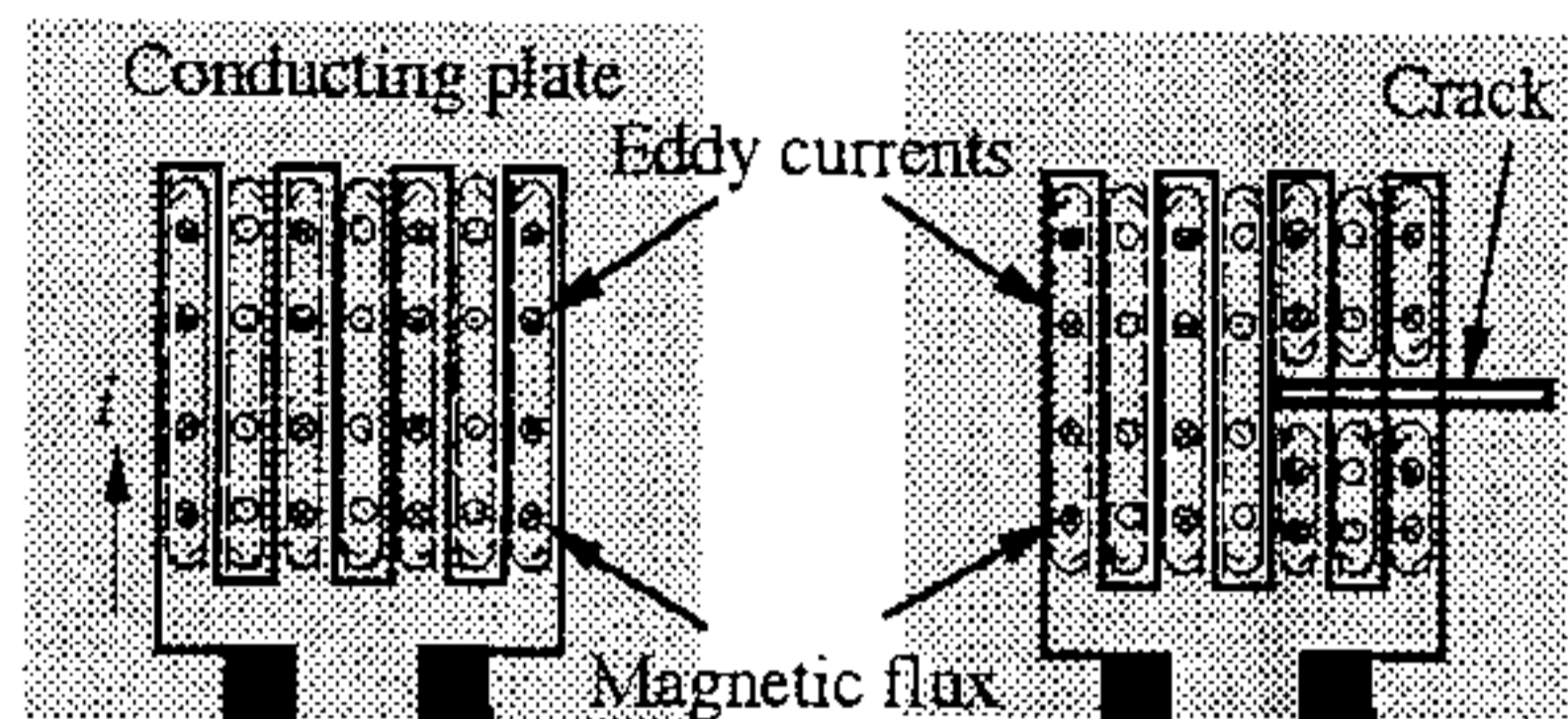

(a) Pattern of eddy currents when there is no crack (b) Pattern of eddy currents when a crack exists

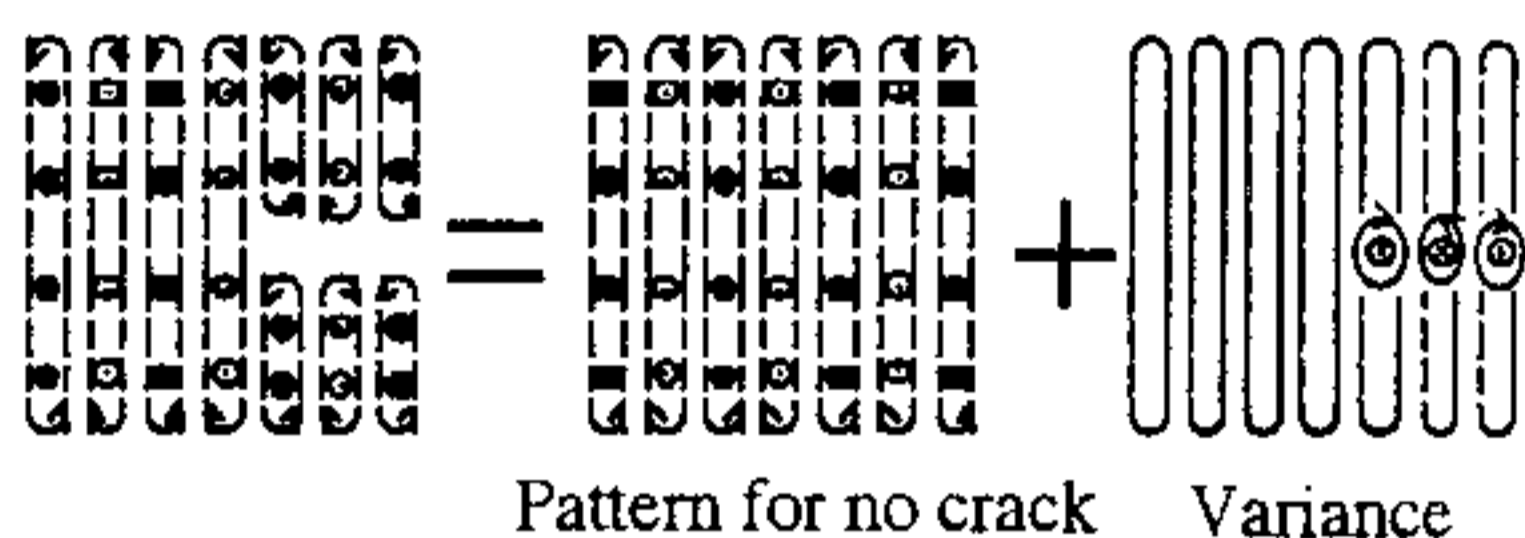

(c) Variance of flux distribution when a crack exists

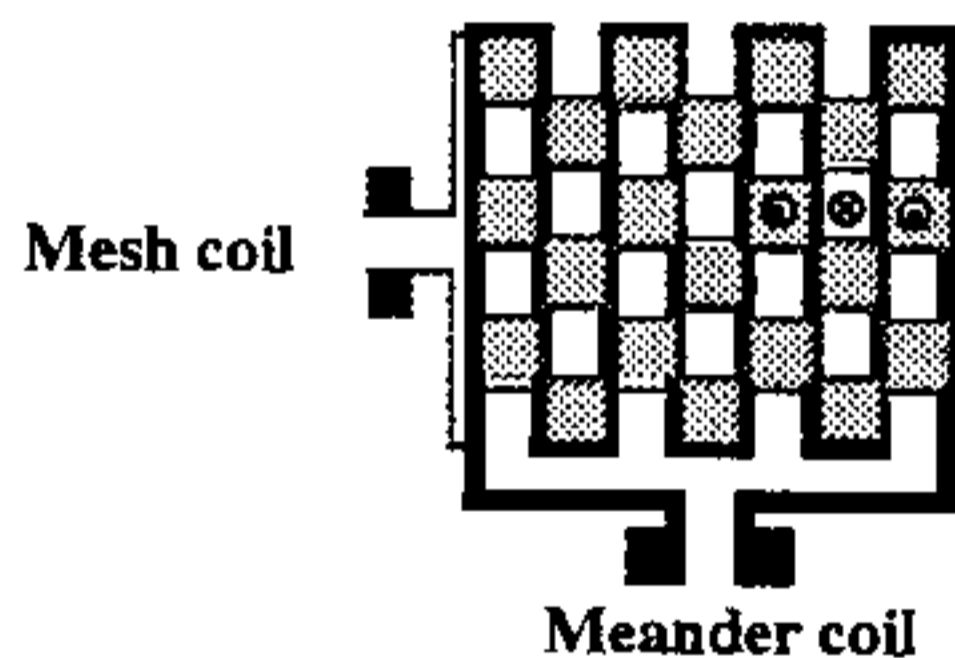

(d) Detection of variance flux using a mesh coil

Fig. 3 Eddy Current Pattern with and without a Crack and the Net Flux Sensed by the Mesh Coil

3. EXPERIMENTAL SETUP AND RESULTS

Fig. 4 shows the experimental apparatus which was used to conduct tests on the ECT probe. Figs. 5(a) and 5(b) show the dimensions of the meander coil and mesh coil respectively. Fig. 6 shows the dimensions of the crack which were used throughout the experiment. Figs. 7(a) and 7(b) show experimental results for the measured induced voltage for motion in parallel to the length of the crack and motion perpendicular to length of the crack. It is clear in both figures that the signal strength decreases as the clearance distance between the sensor and the metallic plate increases. Also measurements taken with small clearances clearly show the discrete nature of the field distribution. These results also show that there is a persistent offset error and that the measured output signal level is relatively low. The signal level strength

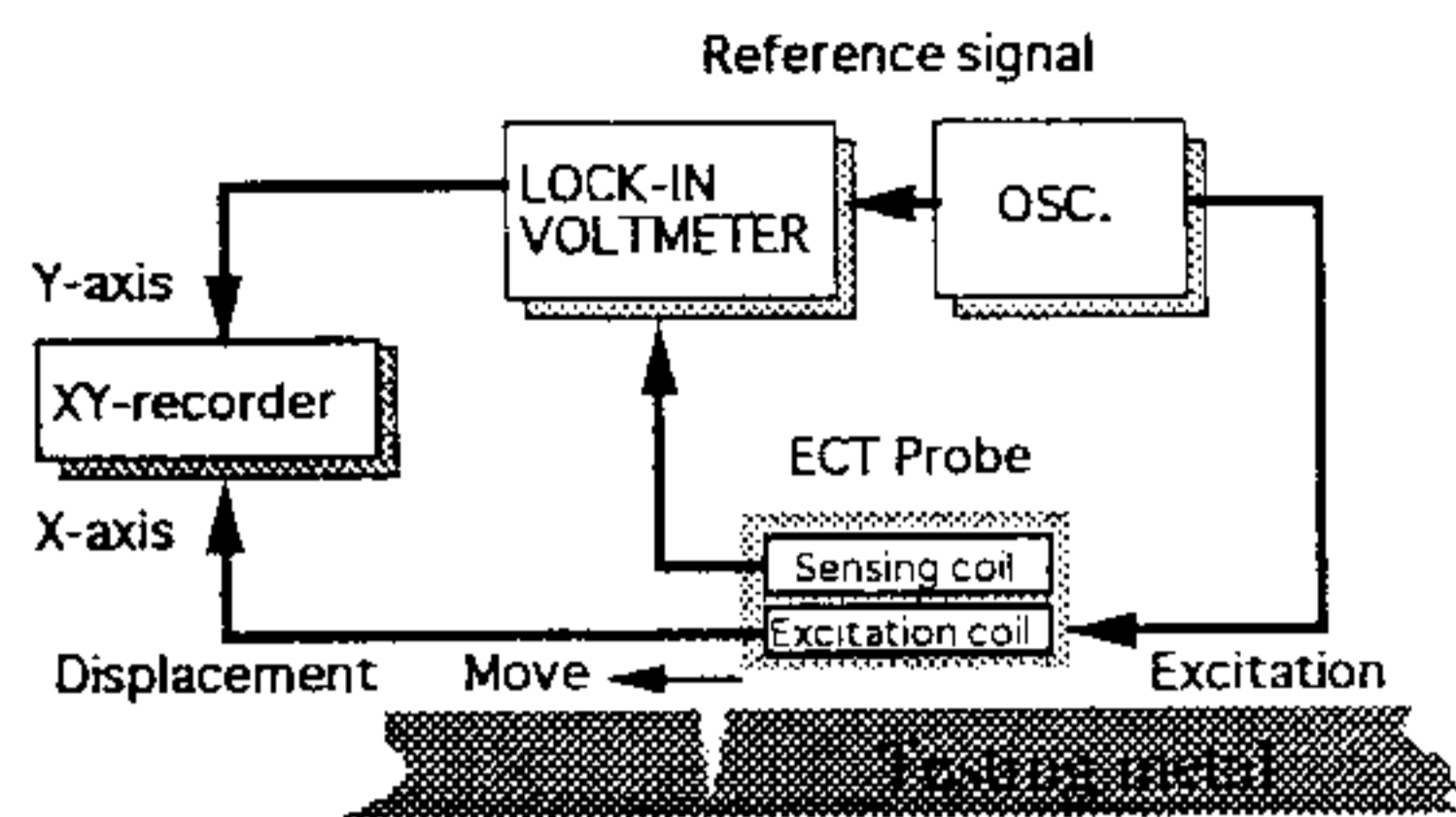

Fig. 4 Measurement System

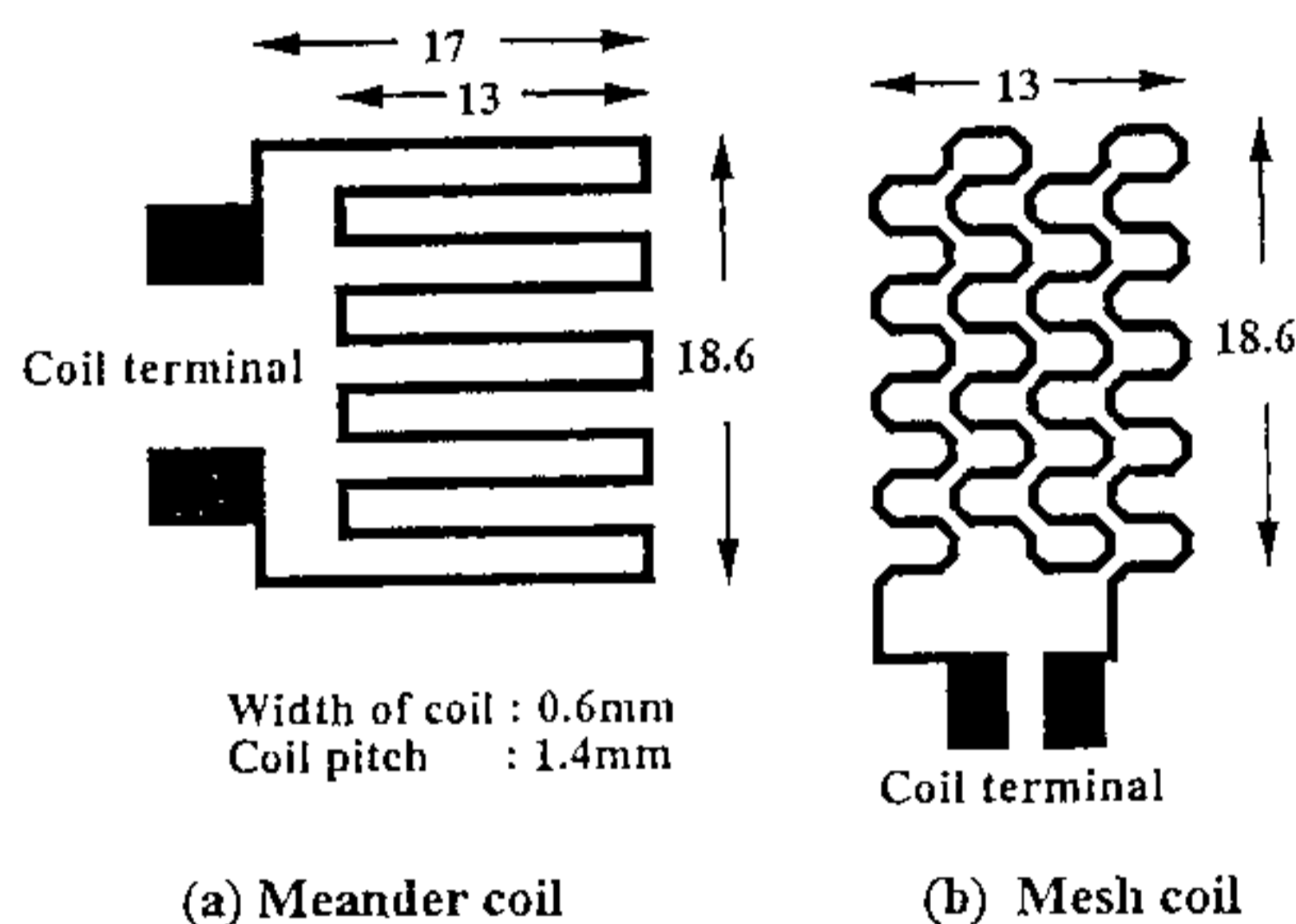

Fig. 5 Coil Pattern

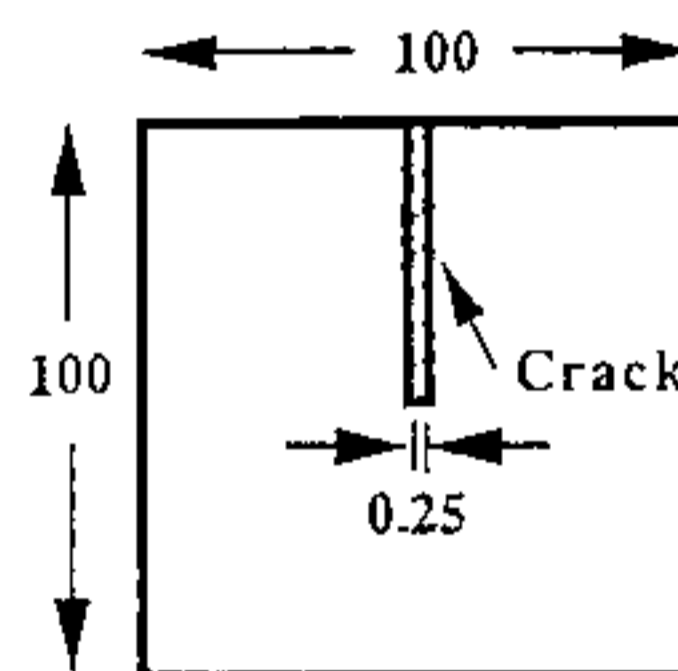
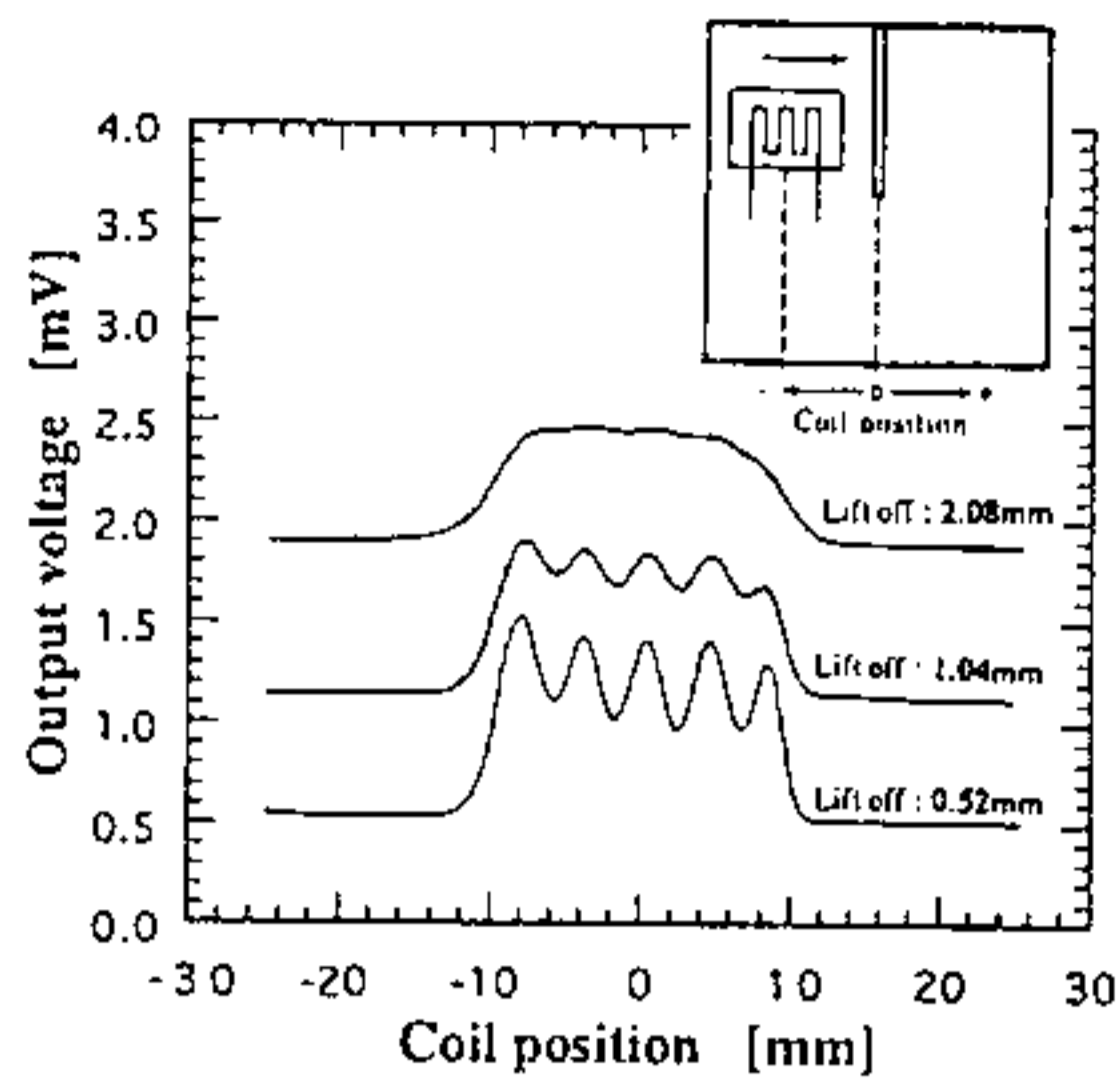

Fig. 6 Placement of a Crack in a Copper Plate

can be increased and the offset error reduced by considering a two coil structure. This is discussed in the next section.

4. EXPERIMENTAL RESULTS FOR AN IMPROVED STRUCTURE

Fig. 8 shows a coil construction which significantly reduces the offset error and increases the signal strength. Two mesh coils placed over top of each other are connected in series and are displaced 180° with respect to each other. This configuration results in the near cancellation of the offset voltage and a factor of two increase in the sensed voltage. Fig. 9 shows the dimensions of the meander and mesh coils which were used in this experiment. Figs. 10(a), 10(b), and 10(c) show the experimental results for the voltage measured across the top



(a) Crack length parallel to the motion of the coil assembly

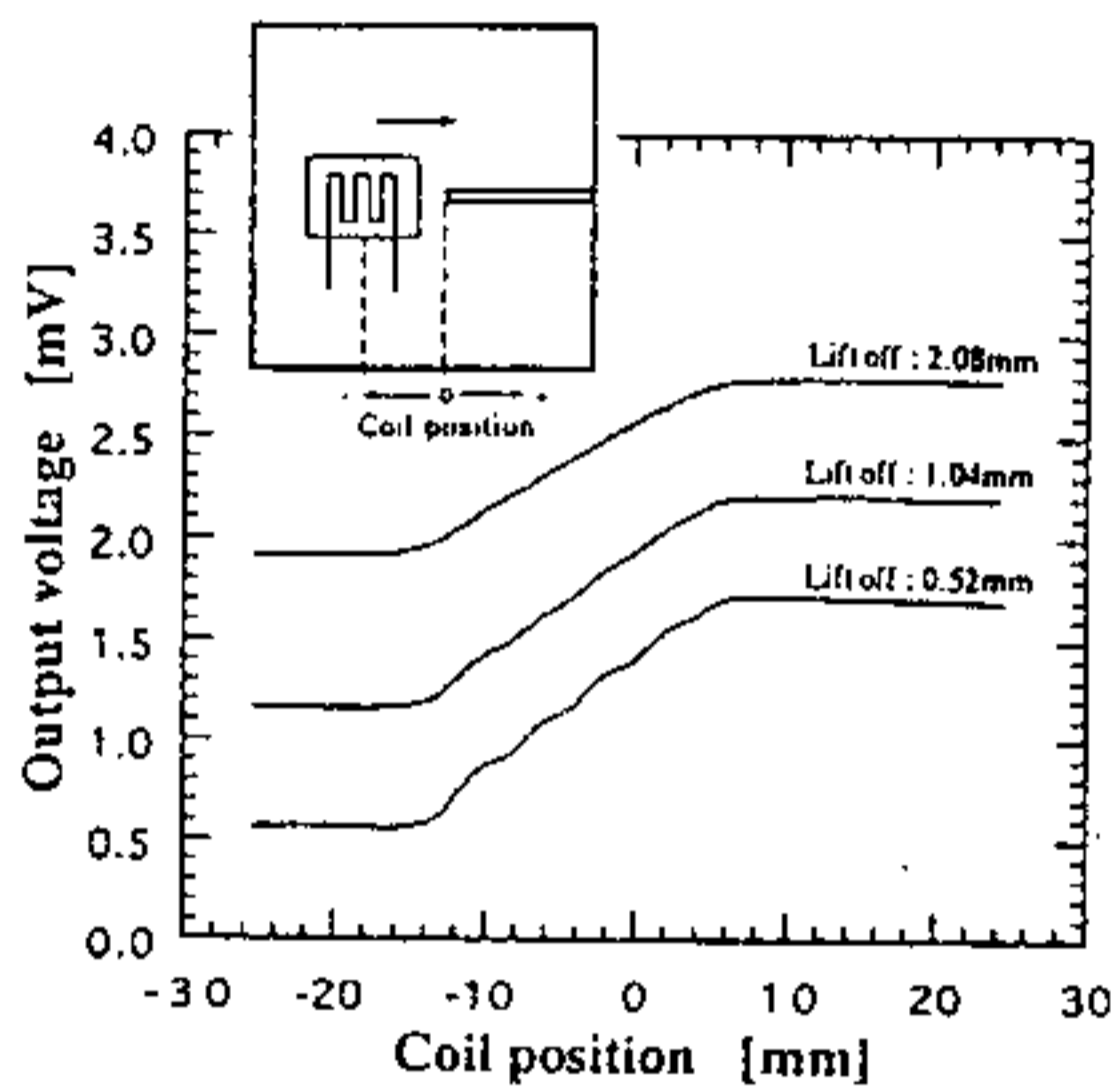

(b) Crack length perpendicular to the direction in motion of the coil assembly

Fig. 7 Induced Voltage as a Function of Test Structure to Coil Clearance and Crack Orientation

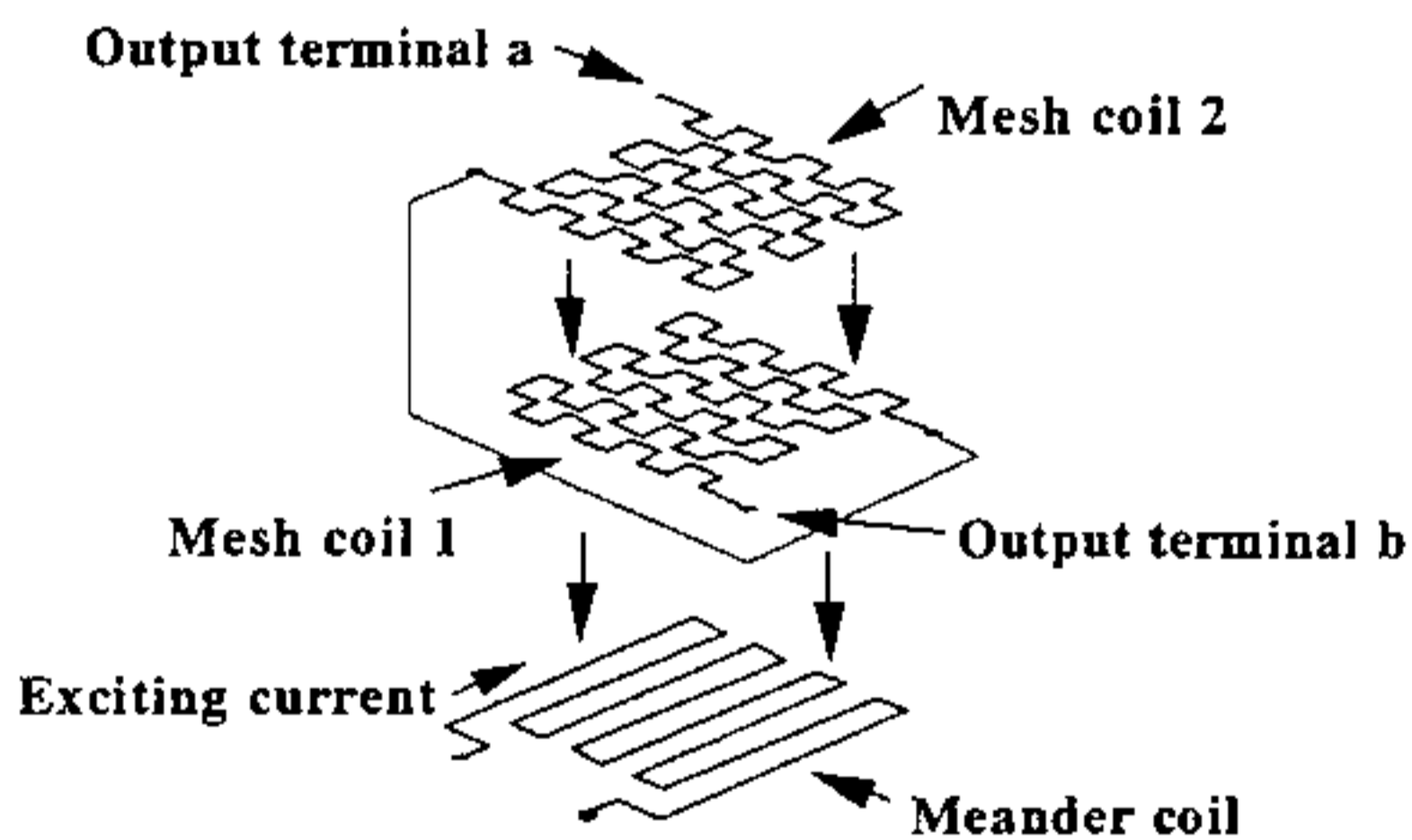

Fig. 8 Two Mesh Coil Configuration

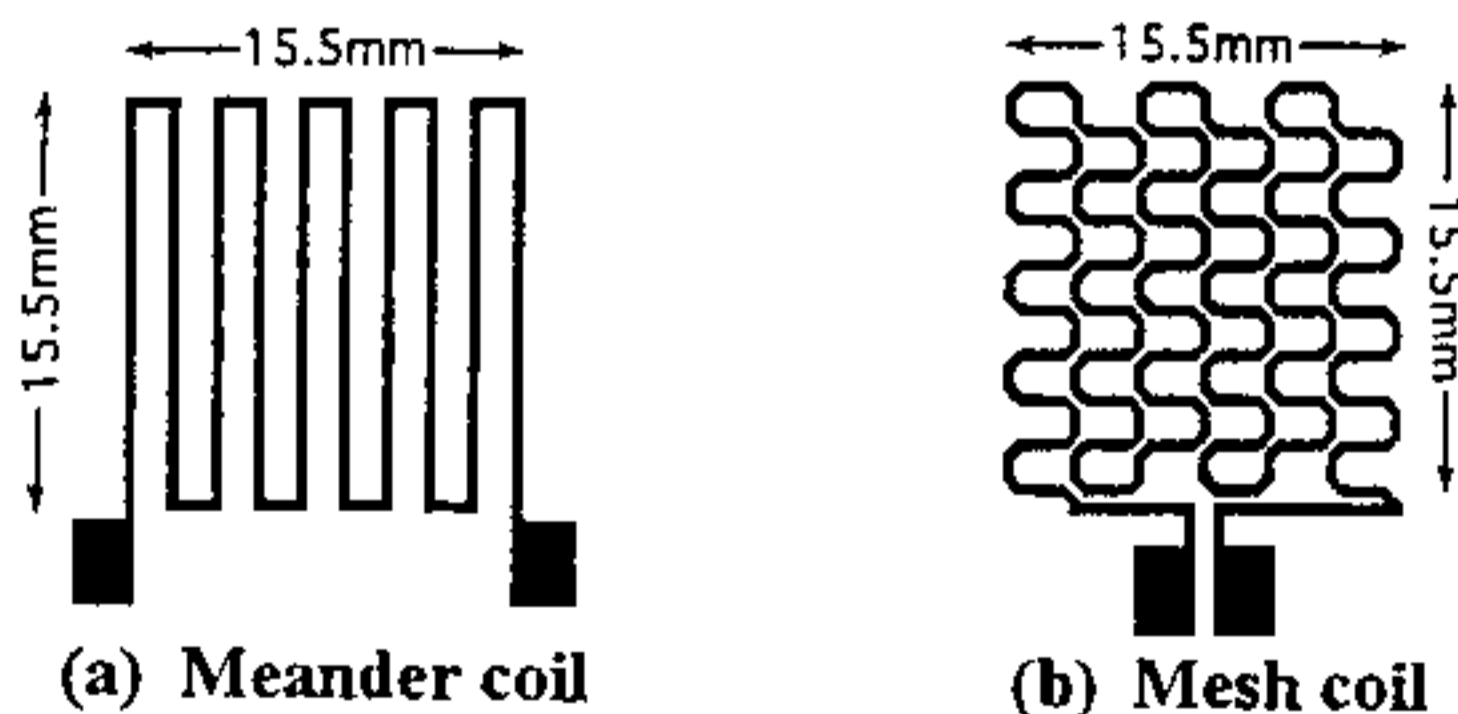
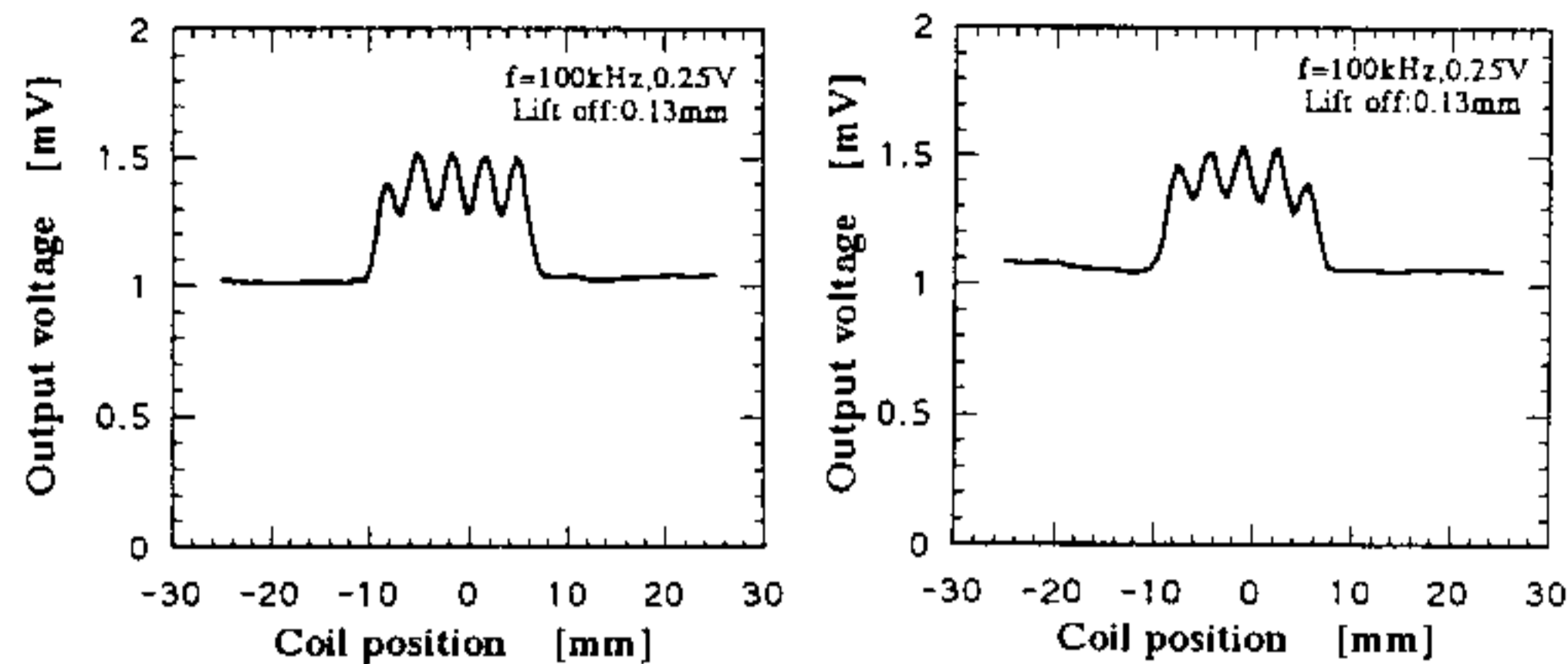
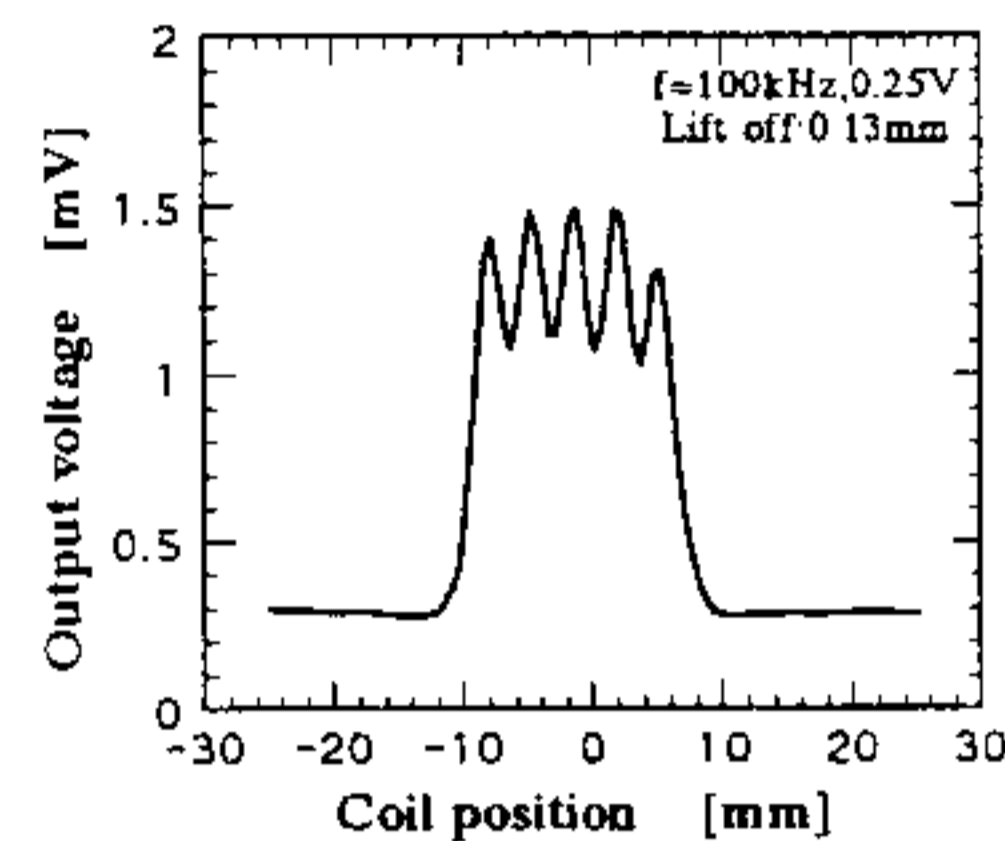

Fig. 9 Coil Structure



(a) Mesh coil 1 voltage

(b) Mesh coil 2 voltage



(c) Sum of voltage across mesh coil 1 and 2

Fig. 10 Experimental Results

coil, the bottom coil, and across the two coils respectively. The residual offset error is attributed to a misalignment in the two coils.

CONCLUSIONS

This paper has experimentally demonstrated that the signal obtained from a micro planar secondary mesh coil placed over top of an exciting meander coil is larger and has less output noise than the signals obtained from conventional eddy-current testing probes. The sensed output voltage waveform was shown to have a discrete nature with an interval governed by the pitch of the mesh coil windings. The experimental results showed that the signal levels were low and that an offset voltage existed. Increased signal strength and a reduction in the offset voltage were facilitated by constructing a two layer series connected mesh coil and orienting the two coils 180° apart. Experimental results confirmed the resultant increased signal strength and the lowering in the offset voltage.

REFERENCES

- [1] J. R. Bowler, S. A. Sabbagh, L. D. Sabbagh, "The Reduced Impedance Function for Cup-Core Eddy-Current Probes", IEEE Trans. on Magnetics, Vol. 25, No. 3, May 1989, pp. 2646-2649.
- [2] K. Kawabe, H. Koyama, K. Shirae, "Planar Inductor", IEEE Trans. on Magnetics, Vol. 20, No. 5, September 1984, pp. 1804-1807.