

Pulse glucometry: A new approach for noninvasive blood glucose measurement using instantaneous differential near-infrared spectrophotometry

著者	Yamakoshi Kenichi, Yamakoshi Y.
journal or publication title	Journal of Biomedical Optics
volume	11
number	5
page range	054028
year	2006-09-01
URL	http://hdl.handle.net/2297/3467

Pulse Glucometry: A New Approach for Non-invasive Blood Glucose Measurement Using Instantaneous Differential Near Infrared Spectrophotometry.

K. Yamakoshi

Kanazawa University
Graduate School of Natural Science
and Technology
Kanazawa 920-1192, Japan

Y. Yamakoshi

TYT Institute of Technology Corp.
Kanazawa 920-1167

Abstract: We describe a new optical method for non-invasive blood glucose (BGL) measurement. Optical methods are confounded by basal optical properties of tissues, especially water and other biochemical species, and by the very small glucose signal. We address these problems by using fast spectrophotometric analysis in a finger, deriving 100 transmittance spectra per s, to resolve optical spectra (900 to 1700 nm) of blood volume pulsations throughout the cardiac cycle. Difference spectra are calculated from the pulsatile signals thereby eliminating the effects of bone, other tissues, and non-pulsatile blood. A partial least squares (PLS) model is used with the measured spectral data to predict BGL levels. Using glucose tolerance tests in 27 healthy volunteers periodic optical measurements were made simultaneously with collection of blood samples for *in vitro* glucose analysis. Altogether 603 paired data sets were obtained in all subjects and 2/3rds of the data or of the subjects randomly selected were used for the PLS calibration model and the rest for the prediction. Bland-Altman and error-grid analyses of the predicted and measured BGL levels indicated clinically acceptable accuracy. We conclude that the new method, named Pulse Glucometry, has adequate performance for safe, non-invasive estimation of blood glucose.

Keywords: spectrophotometry; biomedical optics, infrared spectroscopy

Paper 0534R received Nov. 17, 2005; revised manuscript received Apr. 17, 2006; accepted for publication Jun. 22, 2006

1. Introduction

In vivo spectrophotometric analysis attracts attention due to its potential for allowing safe, convenient, non-invasive biochemical measurement. Whilst the prospects for general biochemical analysis are often proposed and discussed much of the attention has actually been focused on blood glucose (BGL) measurement because reliable BGL assessment is a vital part of self-care by the increasing number of diabetic patients worldwide. Optical methods apart, for more than four decades improved BGL monitoring based on other principles has also been sought, in particular to eliminate the need for the frequent, often painful, finger-pricking and blood analysis which, even today, remains the most

widely used method. Over this period several potential alternatives have emerged, including invasive implantable micro-sensors^[1, 2], the minimally invasive procedure of skin microporation using a laser or miniaturized lancets^[3], as well as transdermal measurement based on extraction of interstitial fluids through the skin using iontophoresis^[4, 5] or sonophoresis^[6]. The subject has been reviewed by several authors; see, for example ref. [7].

Truly non-invasive BGL measurement has been sought for many years and optical methods in general have appeared to offer very strong prospects for achieving this^[8, 9, 10]. These optical methods have included the measurement of the rotation of optical polarisation in the aqueous humor of the eye^[11, 12] or a colorimetric contact lens measuring in tear film^[13] or the use of near infrared spectroscopy, NIRS, in tissues such as the finger or the lip^[14, 15]. Raman spectroscopy has also been investigated for this purpose^[16]. Most of these methods have been explored

Address all correspondence to Prof. Ken-ichi Yamakoshi, Graduate School of Natural Science and Technology, Kanazawa University, Kakuma, Kanazawa 920-1192, Japan; Tel: +81-(0)76-234-4735; Fax: +81-(0)76-234-4739; E-mail: yamakosi@t.kanazawa-u.ac.jp

widely but to date, apparently, none has provided sufficiently precise and accurate measurements for reliable clinical use^[14]. The obstacles to success with *in vivo* NIRS for BGL measurement are, on the one hand, the very small *in vivo* spectral signal of glucose and, on the other hand the combination of interference from other absorbing species, multiple scatter in skin, muscle and bone, and the strong absorption bands of water^[9, 17, 18]. Indeed, the optical absorption spectrum of water effectively masks glucose absorption bands as determined with conventional NIR spectrophotometers. There are clearly substantial difficulties in using spectroscopic techniques for non-invasive measurement of glucose not least of which is that often methods used for assessing the validity of a given technique are not fully described by authors, as reported by Arnold and Small^[18].

We have recently designed a novel NIRS technique^[19], which we term *Pulse Glucometry*. This method has been designed to minimise, or remove, influences of many of the confounding factors by collecting optical data from pulsatile blood volume changes in tissue. There is a substantial literature describing uses of photoplethysmography for monitoring several physiological variables such as blood volume and flow, oxygen saturation and blood constituents such as glucose^[15, 20, 21, 22, 23]. The invention of pulse oximetry by Aoyagi^[24, 25] has had the most important clinical impact of all of these developments to date. The essence of this technique is to make photoplethysmographic measurements of arterial blood volume pulsations, typically at two wavelengths, one in the red and the other in the infra-red parts of the spectrum, then to derive simple ratios of these measurements to determine the relative proportions of the two most significant chromophores oxy- and deoxy-haemoglobin. The patent literature reveals many attempts to use spectrophotometric techniques to measure blood glucose and a method based on two-wavelength analysis of the arterial pulse signal has been proposed^[26]. The invention by these authors claims to use one wavelength which is “glucose sensitive” and a second wavelength which is “glucose insensitive” then, as with pulse oximetry, to use ratios of pulsatile-to-continuous components of the photoplethysmogram at each wavelength to derive an estimate of glucose concentration. Although this invention was classified as a granted patent in 1992 no instrument has yet been made available for use. In fact, this situation is characteristic of the non-invasive glucose monitoring field, where numerous

granted patents exist and no clinically accepted instrument is yet available.

This paper represents our first description of Pulse Glucometry together with preliminary *in vivo* results. There is clearly much more research to be done before all technical and clinical aspects of our method have been fully investigated. For example, we must thoroughly investigate further the performance of the chemometric methods of analysis which we have used, since there are many possible shortcomings as pointed out by others^[15, 18]. Nevertheless, we feel that the results obtained to date are sufficiently encouraging to report the method as one worth serious consideration in this field of non-invasive blood glucose monitoring.

Basic Principle of the Measurement

The method described here utilises spectrophotometric analysis in a tissue segment, such as a finger. Glucose exhibits several absorption bands between 0.7 μm and 2.5 μm and within this range it is of importance that there are broad and strong water absorption bands at 1.45 μm and 1.92 μm ^[27]. In order to avoid these bands it appears theoretically possible to use the combination region (2.0 μm to 2.5 μm), the first overtone region (1.54 μm to 1.82 μm) and the near infra-red region (0.7 μm to 1.33 μm). Glucose exhibits three absorption bands in each of these regions: 2.10 μm , 2.27 μm and 2.32 μm in the combination region; 1.73 μm , 1.69 μm and 1.61 μm in the first overtone region; 0.76 μm , 0.92 μm and 1.00 μm in the near infra-red region. Of these glucose absorption bands the latter in the near infra-red region are particularly weak^[14, 15]. To recover the glucose information in tissue having high water content multivariate analysis covering a suitable region of the optical spectrum must be used. The essence of our new approach is to utilise a blood volume change in a tissue segment under optical interrogation, such as a finger, and then, with a subtraction process, to derive changes in optical density (OD) in order to remove the influences of basal interfering elements.

We assume a simplified model of the tissue under interrogation, as shown in Fig 1, (left panel). This optical model comprises of three compartments: arterial; venous; and bloodless tissue. The optical interrogation of the tissue is carried out with a broad-spectrum light source having incident radiation intensity I_0 with the wavelength λ . Following absorption and scattering in each compartment we have transmitted radiation intensity, I_λ . The arterial blood volume changes in a pulsatile way throughout the cardiac cycle,

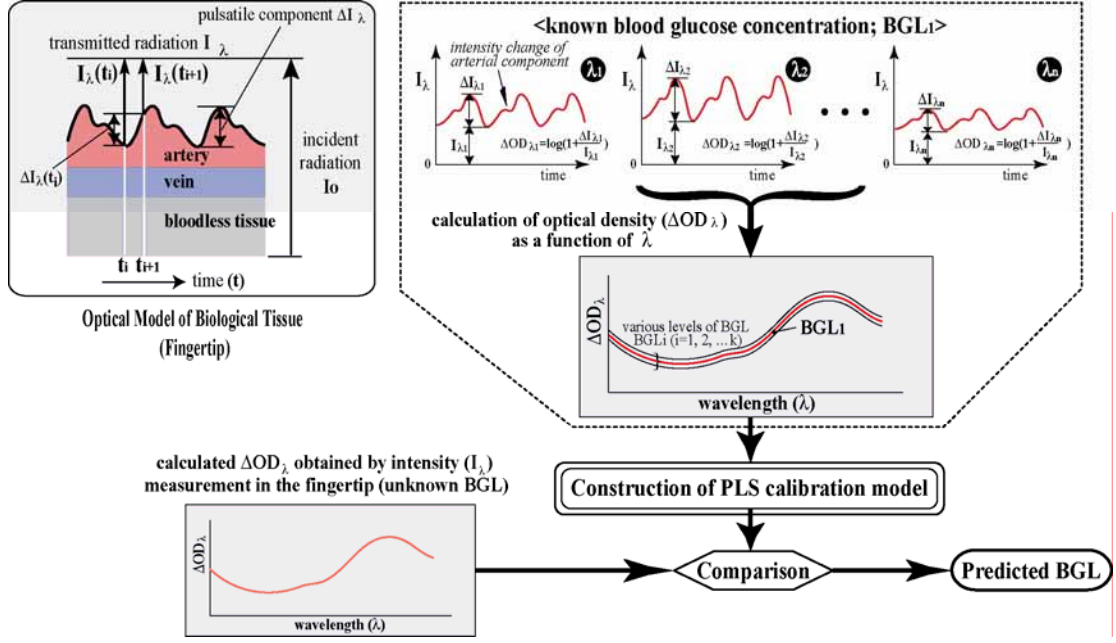

Fig. 1: Basic principle of non-invasive measurement of blood glucose concentration (BGL) using instantaneous differential near-infrared spectrophotometry. Optical model of the biological tissue (fingertip) is shown in the inset in the left panel. See text for explanation.

thereby producing small changes in the transmitted intensity, ΔI_λ . If the transmitted intensity, I_λ , is detected periodically at time intervals Δt during the cardiac cycle, we obtain a time series for I_λ :

$$I_\lambda(t) = (I_\lambda(t_1), I_\lambda(t_2), \dots, I_\lambda(t_n)) \quad (1)$$

and,

$$\Delta t = t_{i+1} - t_i \quad (2)$$

The time series will effectively represent the cardiac-related pulsatile intensity change superimposed upon the basal component, which relates to venous blood, bloodless tissue and non-pulsatile arterial blood. Differences between the optical densities at successive time intervals can then be obtained, since:

$$OD_\lambda = \log(I_0 / I_\lambda(t_i)) \quad (3)$$

$$OD'_\lambda = \log(I_0 / I_\lambda(t_{i+1})) \quad (4)$$

Subtracting OD_λ from OD'_λ we can obtain the difference of optical density at time t_i , ΔOD_λ , as:

$$\Delta OD_\lambda = \log \frac{I_\lambda(t_i)}{I_\lambda(t_{i+1})} = \log \left(1 + \frac{\Delta I_\lambda(t_i)}{I_\lambda(t_{i+1})} \right) \quad (5)$$

where, $I_\lambda(t_i) = I_\lambda(t_{i+1}) + \Delta I_\lambda(t_i)$

This subtraction has the effect of removing the venous and the tissue contributions to yield only the change in intensity due to the pulsating arterial blood compartment. If now the transmitted radiation is spectrally resolved into its component individual wavelengths it will be possible to recover a family of time-series, each member displaying the pulsatile intensity change present at one wavelength, as shown in Fig. 1 (upper panel). In order to implement this general principle in practice we use the peak-to-peak magnitude of each cardiac-related pulse. The magnitudes of the cardiac-related pulsatile intensity components at wavelengths $\lambda_1, \lambda_2, \dots, \lambda_n$ are given as $\Delta I_{\lambda_1}, \Delta I_{\lambda_2}, \dots, \Delta I_{\lambda_n}$. Based on equation (5) we can then convert these into changes in optical density $\Delta OD_{\lambda_1}, \Delta OD_{\lambda_2}, \dots, \Delta OD_{\lambda_n}$.

These data can also be viewed as spectra, for example over a near infra-red range, with ΔOD_λ plotted against wavelength, λ . If such spectra are derived at different levels of blood glucose concentration, BGL_i , we will obtain a family of spectra, as is illustrated schematically in Fig. 1(lower part), which may then be used for a multivariate analysis. As is common in multi-component spectrophotometric analysis we use a Partial Least Squares (PLS) calibration model in order to obtain predictions of BGL [8, 9, 10, 15, 18, 23, 27, 28]. The PLS model is first constructed by measuring blood glucose directly together with non-invasive optical measurements in a representative population. Then, for a given

subject, spectra of ΔOD_λ vs λ for the unknown BGL values derived from *in vivo* measurements are compared with the PLS-derived calibration model and predicted BGL values thereby calculated.

Materials & Methods

In order to obtain an instantaneous spectrum of the transmitted radiation through the tissue, we have developed a new, fast, spectrophotometer. Fig. 2 shows a block diagram of this system. It comprises of a light source (halogen lamp: maximum power; 150 W), an optical fibre bundle

in vitro assessment, we recorded sequential transmission spectra from a 1.0 mm cuvette containing water and then calculated the difference between sequential pairs of spectra. This indicated a spectral noise value of 20 μ AU over the chosen operating wavelength range from 900 to 1700 nm. We then inserted a neutral density filter having an attenuation of 2.0 AU into the optical path, in addition to the 1.0 mm cuvette containing water, and once again repeated the acquisition of sequential spectra together with calculation of the difference spectra. This gave us a spectral noise value of around 30 μ AU over the same wavelength range. Secondly, we ac-

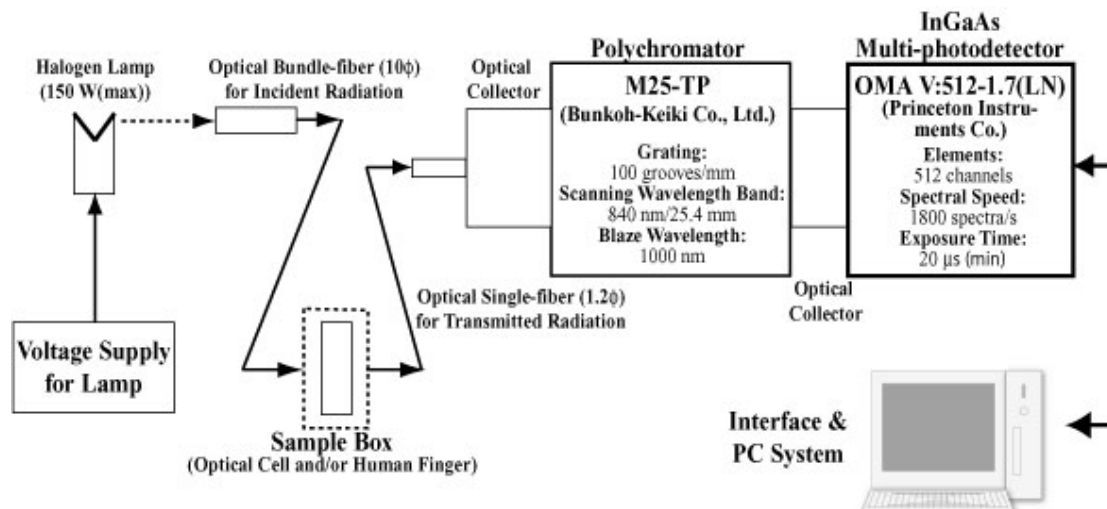

Fig. 2: Block diagram of the high-speed near infrared spectrophotometric system. See text for details.

of 10 mm diameter for the incident radiation and a single fibre of 1.2 mm diameter for receiving the transmitted radiation, a spectrometer (polychromator: M25-TP; Bunkoh-Keiki Co. Ltd., Japan), a linear, liquid nitrogen cooled (-50 - -100 \square), InGaAs photodiode-array (multi-photo-detector: OMA V: 512-1.7(LN); Princeton Instruments Co., USA), and a conventional PC with an appropriate interface. The spectrometer covers an effective wavelength range from 900 nm to 1700 nm with a resolution of better than 8 nm, and it has a maximum spectral rate of 1800 spectra/s with 1 MHz digitization (16 bits), and a minimum exposure time of 20 μ s. A key component of our instrument is the multi-photo-detector. The model we used has a particularly high specification, and in terms of dark current, linearity and stability it is at present probably one of the best commercially available worldwide (see detailed information: http://architect.wwwcomm.com/Uploads/Princeton/Documents/Datasheets/omav_512-17ln.pdf). The spectral noise of the instrument was evaluated both *in vitro* and *in vivo*. Firstly, for the *in*

quired sequential transmission spectra from a fingertip whilst an occlusion cuff was applied around the basal phalanx of the finger to halt blood circulation for a period of about 5 s. Once again this allowed us to derive difference spectra from the sequential pairs of transmission spectra to determine the spectral noise value, but it also enabled us to assess stability and repeatability over the 5-s period. The spectral noise level was found to be around 30 μ AU over the wavelength range of 900 to 1700 nm. For about 50 sequential measurements made over the 5-s period, with an exposure time of 10 ms in the multi-photo-detector, we found a spectral noise variation of around 0.5 %.

In order to carry out *in vivo* measurements glucose tolerance tests were carried out in 27 healthy volunteers, after obtaining informed consent (20-43 years old; 24 males and 3 females). The subjects were asked to abstain from food and alcohol from 9 pm on the previous day until the end of the experiment on the next morning. The experiment began at 9 am in a tempera-

ture-controlled room held at 25 °C. During the experiment the subjects were requested to sit quietly in a chair to undergo the test. Radiation intensity measurements were made in the left index fingertip at regular intervals before and after oral administration of glucose solution (75g/225ml: Trelan-G75; Shimizu Seiyaku, Co. Ltd., Japan) for a study period of 120 min. During the optical measurement the subject's left hand was held horizontally at heart level. In some subjects the interval between optical measurements was 10 minutes and in the remainder the interval was 5 minutes. Immediately after each optical measurement blood samples (about 3 ml) were collected from the cephalic vein of the left forearm. The sampled blood was immediately analyzed by an automatic blood analyzer (DRI-CHEM 7000; Fujifilm Medical Co. Ltd., Japan) to obtain the reference BGL value (measured BGL). The analyzer uses a colorimetric principle based on glucose oxidase contained within single-use multi-layer film elements. Quality control data accompanying each film element are entered into the analyzer thereby ensuring automatic updating of calibration with every use.

For the optical intensity measurements, the fingertip was placed carefully in an adjustable space between the ends of the transmitting and receiving fibres so as to contact softly with the skin (see the inset in Fig. 3). The intensity measurements were made for about 20-30 s (about 20-30 cardiac pulses), spectra being gathered at a rate of 100 s⁻¹. These conditions could achieve a measurement of the pulse component signal (ΔI_λ) superimposed on the intensity (I_λ) with a signal-to-noise ratio (SNR) of more than 25 dB over the wavelength range from 900 to 1400 nm and approximately 22 dB from 1400 to 1700nm. In the calculation of the change in absorbance (ΔOD_λ), however, since we have confirmed this SNR to be more than 20 dB above 1400 nm, we believe that the calculated ΔOD_λ is sufficiently accurate within the range from 900 to 1700 nm. In order to gain an impression of the instrument noise level we can see from the spectra shown in Fig 5 that there is noise just discernable on the tracing, especially at higher wavelengths.

In each subject during the 120-min study period 13 (10-min interval) or 25 (5-min interval) sets of the intensity measurements were made whilst the BGL was changing; the measured BGL values varied from about 80 to 220 mg/dl in all of the subjects. The beat-by-beat spectral data of blood

(ΔOD_λ) against a measured BGL were calculated to obtain an averaged spectral curve of ΔOD_λ obtained from stable and almost similar waveforms of the pulsatile intensity changes of 3-5 consecutive cardiac beats during the measurement interval of 20-30 s. The spectrum of ΔOD_λ was then normalised, using the value of the ΔOD_λ at 900 nm as 1.0 together with the minimum value of ΔOD_λ as 0. Thus 603 paired data sets of the measured BGL values and the normalised spectra of ΔOD_λ were obtained from the 27 healthy volunteers for use in the PLS modelling for which we employed the MATLAB™ PLS Toolbox 3.5 (Eigenvector Inc., USA). We have used 2/3^{ds} of the data for deriving the PLS calibration model and the remaining 1/3rd for prediction. Two methods for selecting the data were used: (A) In the first method we randomly selected 402 data sets for calibration and used the remaining 201 data sets for prediction; (B) In the second method we randomly selected 18 subjects, using all of their data for calibration, leaving the data from the remaining 9 subjects for prediction. The analysis based on method (B) then allowed us to plot the time-course of predicted and measured BGL in any of the 9 subjects.

Results

The optical data collected during each 20-30 s measurement period allowed transmittance spectra to be plotted and for the temporal changes throughout each cardiac cycle to be seen. Fig. 3 shows an example of a 3-dimensional representation of the transmitted radiation intensity in arbitrary units (a.u.) (I_λ a.u.: vertical axis, y), vs wavelength λ (nm, horizontal axis, x) and vs time

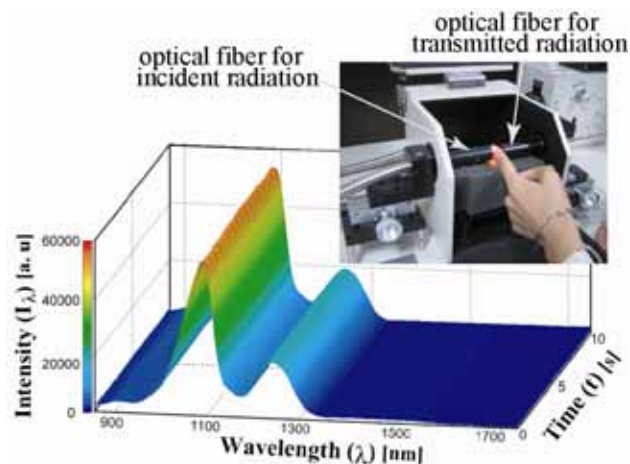

Fig. 3: An example of 3-dimensional display of transmitted radiation intensity (I_λ), wavelength (λ) and time (t) measured in the fingertip. Measuring scene is shown in the inset.

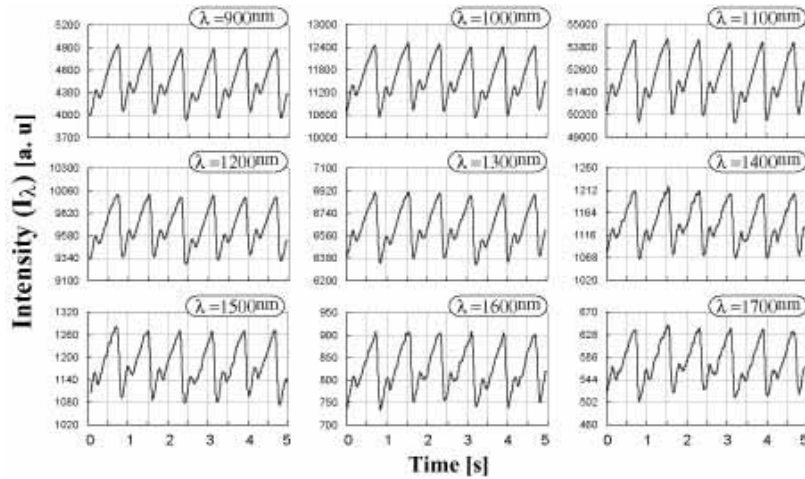

Fig. 4: Examples of pulsatile component (ΔI_λ) records superimposed on the transmitted radiation intensity (I_λ) measured from $\lambda = 900$ to $\lambda = 1700$ nm every 100 nm step obtained in the fingertip of the same subject in Fig 3.

t (s, horizontal axis, z) measured in the fingertip of a female subject. From these transmittance spectra it can be seen that the intensity exhibits a peak around 1100 nm and it is considerably decreased beyond approximately 1200 nm due to the strong absorption by the water component in the tissue, including blood. Pulsatile intensity changes with time, being of cardiac origin, can be seen as a ‘ripple’ on the peak intensity at 1100 nm. These pulsatile changes are then shown more clearly in Fig. 4 for specific wavelengths at 100 nm intervals from 900 nm to 1700 nm.

The PLS models were assessed by examination of the regression coefficient vectors [9, 10, 15, 18, 28]. Presence of positive peaks in the regression coefficients was seen in the spectral regions associated with glucose absorption indicating that these wavelengths have positive correlations to the tissue glucose content.

As mentioned above we used two methods for selecting sets of data for model calibration and

Fig. 5: (a) An example of the time course of the measured and predicted BGL values before and after oral administration of glucose solution indicated by the arrow, (b) averaged spectrum of optical density (ΔOD_λ) obtained from 4 consecutive cardiac beats at a point (I) in (a) calculated from the light intensities (I_λ and ΔI_λ), and (c) ΔOD_λ spectra which was normalised using the value of the ΔOD_λ at 900 nm as 1.0 together with the minimum value of ΔOD_λ as 0 in each calculated spectrum obtained at the points (I), (II), (III) and (IV) in (a). The time course was obtained from the analysis based on method (B).

prediction, method (A) involving the random selection of 402 data sets from the total 603 data sets and method (B) in which we randomly selected 18 subjects, using all of their data for calibration and the data from the remaining 9 subjects for prediction. Method (B) allows the time-course of measured and predicted BGL levels to be plotted for each individual subject and a typical example of such a time-course of measured BGL levels (Fuji DRI-CHEM) before and after administration of glucose solution is

shown in Fig. 5 (a). Using the pulsatile intensity measurements as shown in Fig. 4 the corresponding optical density changes, ΔOD_λ , were calculated for the whole spectral range and were then averaged for the measured cardiac beats to

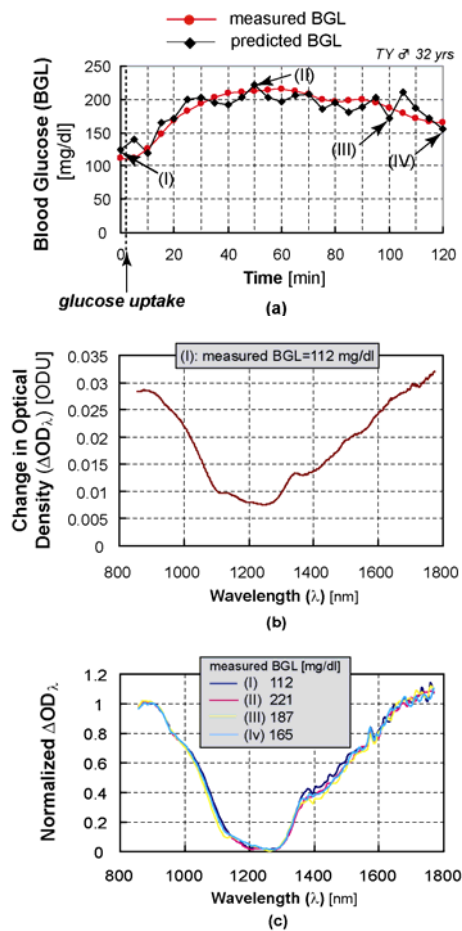

obtain a spectral curve of ΔOD : Standard deviations of the averaged ΔOD_{λ} spectral curves were within 1 % between 900 and 1300 nm and were within about 2 % beyond 1300 nm for the various BGL levels in the present glucose tolerance tests. An example of the averaged ΔOD_{λ} obtained from 4 consecutive cardiac beats is shown in Fig. 5(b), which corresponds to time point 'I' in Fig. 5(a). This procedure was repeated for all of the data collected during the glucose tolerance test, and the resulting spectra corresponding to the BGL values at time points 'I', 'II', 'III' and 'IV', are normalized and are shown in Fig. 5(c). Predicted values of BGL were subsequently calculated using the PLS model and are also plotted in Fig. 5(a) together with the blood analysis results.

For both method (A) and method (B) the paired data sets of the measured (Fuji DRI-CHEM) and predicted (Pulse Glucometry) BGL values were analysed by the Bland-Altman method [29] and

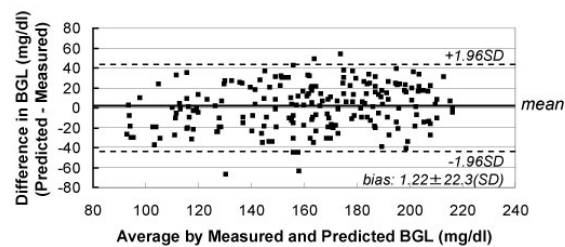

Fig. 6: Difference between predicted and measured BGL values plotted against their average (Bland-Altman plot) analysed by method (A). See text for further explanation.

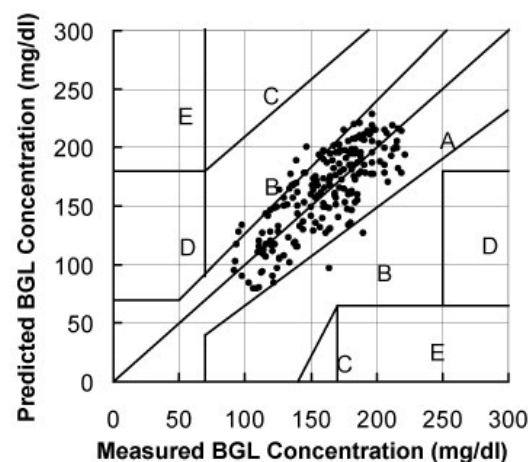

Fig. 7: A scatter diagram showing comparison of the predicted and measured BGL values by error-grid analysis obtained by method (A). Values in regions A and B are acceptable for clinical use. See text for explanation.

also using error-grid analysis [30]. The result of the Bland-Altman analysis for 201 paired data from method (A), corresponding to a range in measured BGL values from 93 to 216 mg/dl, is shown in Fig. 6. The bias and precision of the predictions obtained by Pulse Glucometry as compared with direct blood analysis averaged 1.22 ± 22.3 (mean \pm SD) mg/dl. Using method (B), with 129 paired data corresponding to a range in measured BGL values from 93 to 211 mg/dl, we found a bias and precision of -2.48 ± 21.9 (mean \pm SD) mg/dl.

The error-grid for the results of method (A) is shown in Fig. 7. This indicates that 181 data pairs (90.05 %) fell within region A, and 20 data pairs (9.95%) fell within region B. The error-grid analysis for method (B) showed that 119 data pairs (92.2%) fell within range A and 10 data pairs (7.8%) fell within range B.

These results indicate that, for both methods of analysis (A and B) the new method, Pulse Glucometry, was able to produce BGL estimates with precision and accuracy suitable for clinical purposes.

Discussion

The development of a reliable and convenient non-invasive method for blood glucose (BGL) monitoring in order to avoid the need for blood sampling has been the focus of intense efforts for several decades [1, 3]. Among the possible non-invasive approaches those based on optical methods have seemed attractive but to date there has been no report of an entirely successful instrument [31]. *In vivo* spectrophotometric analysis is confounded by a number of factors, especially the influences of absorption and scatter by numerous tissue components, such as water, bone, muscle, skin and the very many chemical constituents in blood other than glucose [17]. The strong absorption bands of water make the specific extraction of glucose absorption data technically difficult. Our approach is to utilise a change in the blood volume of an interrogated tissue segment, such as a fingertip, produced by the cardiac-related pulse in order to eliminate the basal interfering components. This approach may be compared with the widely used method of pulse oximetry which uses two specific wavelengths for oxygen saturation monitoring [32]. In this connection Heise et al [15] suggested the possible use of diffuse reflectance spectroscopy for glucose measurement on human oral mucosa and that pulsatile absorbance spectral measurement might be further investigated. These authors were unable to measure pulsatile spectra on the lip,

there apparently being problems of the spectral SNR as well as inadequate time resolution of their instrumentation.

We have used venous blood samples for the construction of our PLS model, since venous blood sampling is used clinically and arterial blood sampling was felt not to be justified in healthy volunteers. We have noted optical intensity changes reflecting venous blood volume changes with breathing. It is theoretically possible to use these intensity changes to calculate BGL levels, but the signals are not as clear and reliable as the arterial blood volume pulsations. It is known that arterial BGL values may be 10-20% higher, or more, than venous BGL values [33].

We have designed and constructed a spectrophotometric measurement system which is capable of deriving transmittance spectra from an adult human finger at sufficiently high speed to reveal cardiac-related pulsatile spectra over the near infra-red spectrum from 900 nm to 1700 nm. Reported *in vitro* absorption spectra of whole blood exhibit a large peak at around 1450 nm due to water. Interestingly, we found that the *in vivo* spectrum of the pulsatile blood compartment, as shown in Fig. 5(b) and 5(c), is consistently markedly different to the *in vitro* spectrum, especially in the wavelength range beyond 1300 nm. The reasons for this are at present unclear. However, in their paper on time-resolved near-infrared spectroscopy Nahm and Gehring [22] reported so-called “static” and pulsatile parts of finger tip optical density over the wavelength range from 600 nm to 1012 nm ($16,667\text{ cm}^{-1}$ to 9880 cm^{-1}). The “static” spectrum reveals the known water absorption band around 966 nm, with a magnitude of approximately 0.6 ODU (or AU). However, the water absorption band is missing in the spectrum derived from pulsatile signals, which only reveals a part of the haemoglobin spectrum appearing between 643 nm and 602 nm. These authors do not give a detailed explanation for this finding, merely stating that it can be explained by a strong influence of extra-vascular water on the static spectrum, but no estimates for the relative proportions of the intra-vascular and extra-vascular compartments in the fingertip are given. These authors use a multi-layer model of tissue comprising of bloodless tissue, intra-venous space and intra-arterial space. This model assumes, firstly, that scattering effects are ignored and, secondly, that changes in optical density due to cardiac-related pulsatile blood volume are created by changes in the pathlength of the intra-arterial space. Although it is not clear from the descrip-

tion of their experimental arrangement we assume that the positioning of their optical fibres for the incident and transmitted radiation is such that the finger is free to change diameter during the pulsatile changes in volume/pathlength. By contrast with their arrangement we specifically ensure that our optical fibres are fixed in gentle contact with the opposing surfaces of the finger such that the intra-fibre distance, and therefore the finger diameter, cannot change during the arterial pulse. In this case any changes in intra-arterial volume must be compensated for by opposite changes in intra-venous space. A simple analysis of this situation, bearing in mind that we derive difference spectra, suggests that this may lead to subtraction of the water spectrum. The obvious limitation of this simple analysis is that it does not fully account for changes in attenuation across the finger caused by scattering phenomena and we will study this further in our on-going research, but we now discuss scattering aspects further.

With respect to the matter of water absorption bands and to the critical issues of selectivity and choice of spectral range it is inevitable that scattering phenomena play an important role. Amerov et al [28] show in their *in vitro* studies of blood that the influence of glucose concentration on scattering is the dominant factor in what they refer to as the short-wavelength region. Their work elegantly shows that, *in vitro*, the most important mechanism is that of the influence of glucose uptake by blood cells on refractive index. In defining the three spectral ranges for their studies they do not make a clear distinction between the first-overtone range and the short-wavelength range, simply stating that both are included in the range spanning from 9000 cm^{-1} to 5400 cm^{-1} ($1.11\text{ }\mu\text{m}$ to $1.851\text{ }\mu\text{m}$). They do, nevertheless, demonstrate much greater statistical variation in the glucose concentration correlation plot when using a PLS calibration model with spectral information restricted to the narrow spectral region from 8500 cm^{-1} to 7300 cm^{-1} ($1.176\text{ }\mu\text{m}$ to $1.369\text{ }\mu\text{m}$). The measurements reported in our present paper, which were of course *in vivo* whole tissue not merely *in vitro* blood samples, were actually made over the range of $11,111\text{ cm}^{-1}$ to 5882 cm^{-1} (900 nm to 1700 nm). We therefore include both the first-overtone range and the restricted short-wavelength range used by Amerov et al. It is not clear at this stage what effect this has on the performance of our instrument for blood glucose predictions and the implications of this will be fully investigated in our future research. Suffice it to say that we believe that the influences of scatter are much more

complex in the *in vivo* situation as compared with the *in vitro* model.

The choice of spectral range is important for two reasons; firstly, it obviously influences the ability to recognise the target molecule from its known absorption bands amidst other absorbing species; secondly, it requires consideration of the likely wavelength-dependent effects of scattering phenomena that have a profound influence on optical pathlength. The matter of optical pathlength is critical in any attempt to derive quantitative measurements using spectrophotometry and this is especially important for *in vivo* determinations. Multiple scatter by tissues is a well-known and extensively studied phenomenon and many groups have made measurements of effective optical pathlength^[17]. Actual optical pathlength estimates in some tissues can be made, with varying degrees of precision and accuracy, by using what has been defined as the optical pathlength factor, ζ , which is given by the relationship $L_o = \zeta L$, where L_o is the optical pathlength and L is the physical pathlength^[17]. Some authors refer to this as the differential pathlength factor, or DPF. Measurements of ζ have been made in various tissues and, for example, human brain has ζ ranging from 4 to 5. ζ for the adult fingertip is of a similar magnitude so that if the physical pathlength of the fingertip is 10 mm the optical pathlength could be as much as 50 mm. This clearly has a significant impact on quantitative estimates using spectrophotometric methods.

Several authors, using either time-resolved or frequency domain measurements to measure the reduced scattering coefficient of various tissues (vascular and avascular), have reported wavelength-dependence following classical Mie theory^[34, 35]. Recent studies in the human fingertip over the range 850 nm to 1050 nm actually show clearly the expected linear fall in reduced scattering coefficient with increasing wavelength^[36]. Propagation of radiation through tissues is thus, naturally, influenced by wavelength, but is also influenced by the positioning of interrogating fibres and by applied pressure^[37]. In diffuse reflectance measurements, which are now popular for blood glucose determinations, the penetration depth and therefore the interrogated volume are related to the geometrical spacing between transmitting and receiving fibres^[10].

In common with many others using NIRS for either non-invasive chemical measurement or *in vitro* analysis we have used the multivariate statistical method of PLS regression. Although this method has the potential to provide meaningful predictions great care is needed since it has been

suggested that chance correlations can produce highly misleading results^[14, 15, 18, 31]. It has also been shown that use of time-correlated data as in conventional glucose tolerance tests can lead to false claims of model functionality^[38]. Using a phantom containing fat and aqueous protein solutions to simulate human spectra, but in the absence of glucose, these authors showed that if typical glucose tolerance test time profiles were used in assigning glucose concentrations to spectra within their phantom glucose data set, the PLS calibration models assessed with leave-one-out cross validation performed well; this is a very disturbing finding. In addition they found that models developed with the leave-one-out cross validation method were similar to those based on the use of an independent prediction set.

In order to establish validity of PLS models and their performance in specifically predicting glucose levels some authors employ an examination of the regression coefficient vector^[10]. We examined the vector and, using 5 latent variables, found generally narrow positive peaks at wavelengths characteristic of glucose absorption. For example, there was a positive peak around 1000 nm which is weakly associated with glucose and there was a further positive peak around 1620 nm which is strongly associated with glucose. The presence of these positive peaks at these wavelengths indicates that they have positive correlations with glucose.

In our experimental protocol we used glucose tolerance tests in order to change BGL levels. We then employed two methods for analysing the collected 603 data sets. In method (A) we randomly selected 402 data sets for calibration and used the remaining 201 data sets for prediction. In method (B) we randomly selected 18 subjects, using all of their data for calibration and leaving the data from the remaining 9 subjects for prediction. The reasoning behind this was that random selection from the total data set, as in the method (A), should reduce the possibility that the outcome of the analysis would be influenced by the time-correlated changes of blood glucose produced during the glucose tolerance test present in the data from an individual subject. By contrast, the outcome of the analysis based on the method (B), where all of the data from each of the randomly selected 18 individual subjects were included, has the potential to be influenced by the time-correlated BGL changes. The results as analysed using both the Bland-Altman method and the Clark error-grid were, however, very similar for the two methods, (A) and (B). This

suggests that the time-correlated changes in BGL do not, in fact, have an influence on the analysis.

This first study has been to present the new method of Pulse Glucometry for the non-invasive BGL measurement along with the design of an accurate and high-speed spectrophotometer system, and to evaluate the feasibility of this method using the limited spectral data sets with a multivariate calibration analysis. There is still much to be done to evaluate fully all aspects of this method.

The present instrumentation is laboratory-based and further development is required to investigate the feasibility of designing a small portable device suitable for patient use to achieve self-monitoring. It is also possible that the method could provide the possibility for non-invasive blood analysis of such substrates as triglyceride, albumin, cholesterol, glycated albumin, and so on. Further comprehensive studies will need to be carried out in order to investigate such possibilities.

Conclusions

We have described a new optical method, Pulse Glucometry, for non-invasive determination of blood glucose levels. A high-speed optical instrument has been successfully developed for gathering transmittance spectra from the adult human finger over the wavelength range of 900 to 1700nm. We have been able to determine cardiac-related pulsatile changes in optical density and, using a PLS calibration model for glucose, we have subsequently been able to derive blood glucose estimates non-invasively in twenty-seven healthy adult subjects during glucose tolerance tests. The results indicate that the technique can produce blood glucose estimates with acceptable precision and accuracy for clinical use. Since the present study is a first stage to validate the new method, further work is required to determine fully the performance of the instrument in diabetic subjects and also to assess the full potential of this method for clinical and research purposes.

Acknowledgment

The authors would like to give their sincere thanks to Professor Peter Rolfe, OBH Ltd., UK, for his valuable suggestions and comments on this work and for his assistance in preparing the manuscript. The authors would also like to thank Associate Professor Shinobu Tanaka, Mr Masamichi Nogawa, and Dr Takehiro Yamakoshi, for their technical assistance in this study. Financial support for this work was provided by SMC Corporation, Tokyo, Japan. SMC did not participate in the research in any way.

References

- 1 J. N. Roe and B. R. Smaller, "Bloodless glucose measurements," *Crit. Rev. Ther. Drug Carrier Syst.* 15, 199-241 (1988).
- 2 E. Csoregi, D. Schmidke and A. Heller, "Design and optimization of a selective subcutaneously implantable glucose electrode based on wired glucose oxidase," *Anal. Chem.* 67, 1240-1244 (1995).
- 3 D. Klonoff. "Non-invasive blood glucose monitoring," *Diabetes Care*, 20, 433-437 (1997).
- 4 J. Tamada, N. Bohannon and R. Potts. "Measurement of glucose in diabetic subjects on non/minimally invasive transdermal extraction," *Nature Med.* 1, 1198-1201 (1995).
- 5 G. Rao, P. Glikfeld and R. Guy "Reverse iontophoresis: Noninvasive glucose monitoring in vivo in humans," *Pharm. Res.* 12, 1869-1873 (1995).
- 6 J. Kost, S. Mitragotri, R. A. Gabbay, M. Pishko and R. Langer, "Transdermal monitoring of glucose and other analytes using ultrasound," *Nature Med.* 6, 347-350 (2000).
- 7 D.C. Klonoff "A review of continuous glucose monitoring technology". *Diabetes. Technol. Ther.* 7(5), 770 – 775 (2005).
- 8 M.R. Robinson, R.P. Eaton, D.M. Haaland, G.W. Koepp, E.V. Thomas, B.R. Stallard and P.L. Robinson. "Noninvasive glucose monitoring in diabetic patients: a preliminary evaluation". *Clin Chem.* 38(9), 1618-1622 (1992).
- 9 H.M. Heise "Applications of near-infrared spectroscopy in medical sciences", in *Near-Infrared Spectroscopy*, H.W. Siesler, Y. Ozaki, S. Kawata and H.M. Heise (eds.), Wiley-VCH, pp. 289 (2002).
- 10 K. Maruo, M. Tsurugi, M. Tamura and Y. Ozaki. "In vivo noninvasive measurement of blood glucose by near-infrared diffuse-reflectance spectroscopy". *Appl. Spectrosc.* 57(10), 1236 – 1244 (2003).
- 11 G. L. Cote, M.D. Fox and R.B. Northrop. "Noninvasive optical polarimetric glucose sensing using a true phase measurement technique," *IEEE Trans. Biomed. Eng.* 39, 752-756 (1992).
- 12 B. Guclu, G. A. Engbretson and S. J. Bolanowski, "Constrained optimization of Drude's equations eliminates effects of confounding molecules for the polarimetric measurement of glucose," *J. Biomed. Opt.* 9, 967-977 (2004).

-
- 13 R. Badugu, J.R. Lakowicz and C.D. Geddes, "A glucose-sensing contact lens: from bench top to patient". *Curr. Opin. Biotechnol.* 16(1), 100-107 (2005).
- 14 O. S. Khalil, "Non-invasive glucose measurement technologies: An update from 1999 to the dawn of the new millennium," *Diabetes Technol. Ther.* 6, 660-697 (2004).
- 15 H. M. Heise, A. Bittner and R. Marbach, "Clinical chemistry and near infrared spectroscopy: Technology for non-invasive glucose monitoring," *J. Near Infrared Spectrosc.* 6, 349-359 (1998).
- 16 A.M. Enejder, T.G. Seccina, J. Oh, M. Hunter, W. Shih, S. Sasic, G.L. Horowitz and M.S. Feld. "Raman spectroscopy for non-invasive glucose measurements". *J. Biomed. Opt.* 10(3), 1-9, (2005).
- 17 P. Rolfe, "In Vivo near infra-red spectrophotometry," *Ann. Rev. Biomed. Eng.* 2, 315-354 (2000).
- 18 M.A. Arnold and G.W. Small. "Noninvasive glucose sensing". *Anal. Chem.* 77(17), 5429 – 5439 (2005).
- 19 K. Yamakoshi, "A non-invasive blood constituent measuring instrument and measuring method," International Patent No. PCT/JP03/03587 (2003).
- 20 A.B Hertzman, "Photoelectric plethysmograph of the fingers and toes in man.", *Proc. Soc. Exp. Biol. Med.* 37, 529 (1937)
- 21 T. Aoyagi "Pulse Oximetry: its invention, theory, and future," *J. Anaesth.*, 17, 259-266 (2003).
- 22 W. Nahm and H. Gehring, "Non-invasive in vivo measurement of blood spectrum by time-resolved near-infrared spectroscopy", *Sensors & Actuators B* 29, 174-179 (1995).
- 23 H.M. Heise, A. Bittner and R. Marbach, "Near-infrared reflectance spectroscopy for noninvasive monitoring of metabolites", *Clin. Chem. Lab. Med.* 38(2), 137 – 145 (2000).
- 24 T. Aoyagi, M. Kishi, K. Yamaguchi and S. Watanabe. "Improvement of the ear piece oximeter". *13th Meeting of the Japanese Society for Medical electronics and Biological Engineering*; 90-91 (1974)
- 25 T. Aoyagi, N. Kobayashi and T. Sasaki "Apparatus for determining the concentration of a light-absorbing material in blood" US 4832484 (1989).
- 26 Y. Mendelson, R.A. Peura and H. Harjunmaa "Method and apparatus for monitoring blood analytes noninvasively by pulsatile photoplethysmography". US patent 5,137,023 (1992).
- 27 K. H. Hazen, M. A. Arnold and G. W. Small, "Measurement of glucose in water with first overtone near-infrared spectra," *Applied Spectroscopy*, 52, 1597-1605 (1998).
- 28 A.K. Amerov, J. Chen, G.W. Small and M.A. Arnold "Scattering and absorption effects in the determination of glucose in whole blood by near-infrared spectroscopy", *Anal. Chem.* 77, 4587-4594 (2005).
- 29 J. M. Bland and D. G. Altman, "Statistical methods for assessing agreement between two methods of clinical measurement," *Lancet*, 1, 307-310 (1986).
- 30 W. L. Clarke, D. C. Cox, L. A. Conder-Frederick, W. Carter and S. L. Pohl, "Evaluating clinical accuracy of systems for self-monitoring of blood glucose," *Diabetes Care*, 10, 622-628 (1987).
- 31 H. M. Heise, "Glucose, in vivo assay of," in *Encyclopedia of Analytical Chemistry; Applications, Theory and Instrumentation*, R. A. Meyers, Ed., pp. 1-27, John Wiley & Sons, Ltd., New York (2000).
- 32 P.Å. Öberg, "Optical sensors in medical care," in *Sensors in Medicine and Health Care*, P. Å. Öberg, T. Togawa and F. A. Spelman, Eds., pp. 15-43, Wiley-VCH Verlag GmbH & Co. KGaA, Weinheim (2004).
- 33 R. Haeckel, U. Brinck, D. Colic, H. U. Janka, I. Puntmann, J. Schneider and C. Viebrock, "Comparability of blood glucose concentration measured in different sample systems for detecting glucose intolerance," *Clin. Chem.* 48, 936-939 (2002).
- 34 M.S. Patterson, B. Chance and B.C. Wilson "Time resolved reflectance and transmittance for the non-invasive measurement of optical properties", *Appl. Opt.* 28, 2331-2336 (1989).
- 35 J.R. Lakowicz and K. Berndt "Frequency domain measurements of photon migration in tissues", *Chem. Phys. Lett.* 166, 246 (1990).
- 36 C. Abrahamsson, T. Svensson, S. Svanberg, S. Andersson-Engels, J. Johansson and S. Folestad. "Time and wavelength resolved spectroscopy of turbid media using light continuum generated in a crystal fibre", *Opt Exp*, 12(17), 4103-4112 (2004).
- 37 L.A. Sodickson "Lateral tissue inhomogeneity: a missing link in photoplethysmographic noninvasive measurement of arterial blood constituents", *Clin. Chem.* 45, 1687-1689 (1999).
- 38 M.A. Arnold, J.J. Burmeister and G.W. Small, "Phantom glucose calibration models from simulated non-invasive human near-infrared spectra", *Anal. Chem.* 70(9), 1773-1781 (1998).