

Identification of individual tree crowns from satellite image and image-to-map rectification

著者	Kubo Mamoru, Nishikawa Sun, Yamamoto Eiji, Muramoto Ken-ichiro
journal or publication title	International Geoscience and Remote Sensing Symposium (IGARSS)
page range	1905-1908
year	2008-01-01
URL	http://hdl.handle.net/2297/9571

doi: 10.1109/IGARSS.2007.4423198

Identification of Individual Tree Crowns from Satellite Image and Image-to-Map Rectification

Mamoru Kubo, Shu Nishikawa, Eiji Yamamoto and Ken-ichiro Muramoto
Kanazawa University, Kakuma-machi, Kanazawa 920-1192, Japan
E-mail : kubo@ec.t.kanazawa-u.ac.jp

Abstract—In forest area, there are few landmarks to be ground control points (GCPs) used for registration of satellite images or maps. Additionally, geographic information from the Global Positioning System (GPS) in field measurement survey is insufficient accuracy to identify individual tree crowns from satellite image. In this study, we propose the method of identifying individual tree crowns from satellite image using field measured data. First, in order to obtain the field measured data, we collected several information of individual trees in the test site. These are the tree stand locations, the distances between the tree trunk and outermost branch in eight directions, the diameter at breast height, and tree species. This survey was carried out on 20 September 2006. The area of this site is 160 meter by 80 meter, and there are about 60 canopy trees. Then, using the field measured data, we created the projected on-ground crown map which has the location and shape of individual trees. The each shape of tree crown is octagonal. Next, we detected the regions of tree crown from satellite image. In this study, we used an IKONOS panchromatic satellite image. The spatial resolution of analysis image is 1 meter per pixel. It can be recognized and identified an individual tree crown whose radius is more than 2 or 3 meter. Watershed algorithm was used for image segmentation, based on mathematical morphology considers gray-scale images to be sets of points in a three-dimensional space, the third dimension being the gray level. A gray scale landscape may be segmented according to the watersheds of the image. The segmented regions were classified to discriminate tree crown using the feature of spectral signature. Finally, we found out individual tree crowns related with field measured data from satellite image. Using a GCP by GPS equipment, we performed roughly registration of the satellite image to the projected on-ground crown map. For each tree crown in the map, we found out the same tree, which has the highest corresponding possibility to the tree crown in the map, among segmented regions obtained from satellite image. This tree-to-tree matching algorithm was performed using the fitness value of the location and octagonal shape of both tree crowns in image and map. We could obtain the optimum registration by affine transformation of highest fitness value without ground control points. Consequently, we could identify individual tree crowns from satellite image by image-to-map rectification.

Index Terms—Satellite image, tree crown identification, field measured data, tree-to-tree matching, image-to-map rectification.

I. INTRODUCTION

Forest composed of many trees has an important role in maintaining environmental conditions suitable for life on the earth. Satellite remote sensing technology is the effective method for management and monitoring of forest resources.

In recent years, high spatial resolution satellites were launched, thereby it is possible to obtain detailed informa-

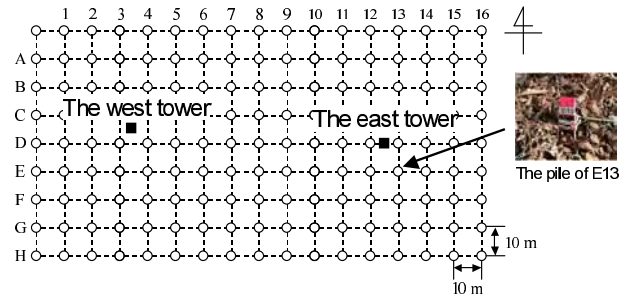

Fig. 1. The illustration of test area. The grid of 10 meter mesh is constructed using piles labeled alphabet and numeric characters. There are two flux towers to measure the exchanges of carbon dioxide between forest and atmosphere.

tion about earth's surface. The IKONOS satellite image can recognize and identify an individual tree crown, it is suitable to monitor a forest covering wide-area. In order to obtain forest management inventories at the stand level, IKONOS satellite images are analyzed instead of the interpretation of aerial photographs[1].

To identify tree crown detected from satellite image using field measured data, we requires high-accuracy image-to-map rectification. However, geographic information from GPS in field survey is insufficient accuracy to identify individual tree crowns from satellite image. Additionally, in forest area, there are few landmarks to be GCPs used for registration of satellite images or maps.

In this study, we propose the method to identify individual tree crown from satellite image by image-to-map rectification. This method is useful for forest management and monitoring.

II. DATA SET DESCRIPTION

The Kitasaku test site of this study is located in the deciduous mixed forest of Nagano prefecture in Japan. This area is 160 meter from west to east and 80 meter from north to south. In this site, there are two flux towers to measure the exchanges of carbon dioxide between forest and atmosphere. In addition, the grid of 10 meter mesh is constructed using piles labeled alphabet and numeric characters. The illustration of this site is shown in Fig.1.

A. Field Measured Data

Field measurement survey was carried out on 20 September 2006. 60 canopy trees with height of 16 to 18 meter were selected in order to create the projected on-ground map.

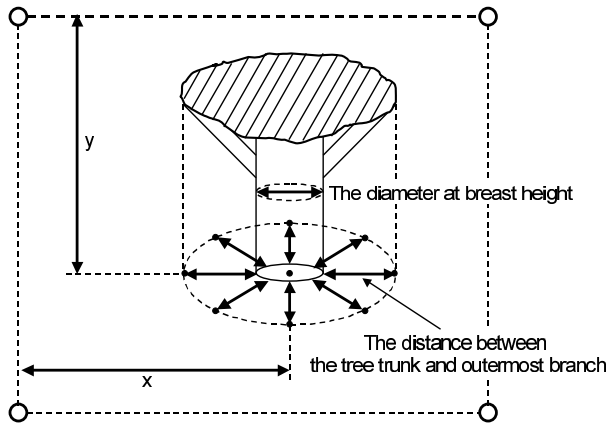

Fig. 2. In the field survey, we measured the tree stand location (x,y) in the labeled block, distances between the tree trunk and outermost branch in eight directions, and diameter at breast height.

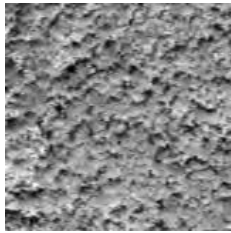

Fig. 3. The IKONOS panchromatic image of the study area. This area is 160 meter by 160 meter.

The relative location of the tree in this area is acquired by measuring the location in the labeled block where the tree stands. The following are the measurement parameters of each canopy tree in this survey:

- (1) tree stand location (x, y) in the labeled block;
- (2) distances between the tree trunk and outermost branch in eight directions (N, NE, E, SE, S, SW, W, NW);
- (3) diameter at breast height.

The positional information of the flux tower was also recorded. The illustration of the field survey is shown in Fig.2.

B. Satellite Image

The satellite data used in this study is an IKONOS panchromatic image. The spatial resolution of analysis image is 1 meter by pixel. It can be recognized and identified an individual tree crown whose radius is more 2 or 3 meter. The image was acquired on 25 August 2003. Fig.3 shows the IKONOS image of the study area. The size of image is 160 meter by 160 meter.

III. METHOD

Fig.4 shows the illustration of image-to-map rectification. First, using the field measured data, we create the projected on-ground map which has the location and shape of canopy trees. Next, we detect the region of tree crown from satellite image. Then, we perform roughly registration of the satellite image

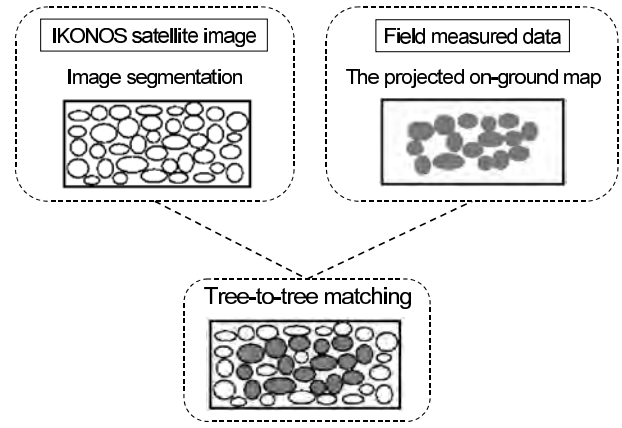

Fig. 4. The illustration of image-to-map rectification.

and the projected on-ground map. This is initial registration. Finally, performing tree-to-tree matching algorithm[2], we obtain the optimum registration and identify individual tree crowns.

A. The Projected On-Ground Map

The projected on-ground map is a figure that represents the location of canopy tree and the shape. The shape of tree crown in this study is octagonal. We obtained the projected on-ground map from the measurement data of 60 canopy trees.

B. Image Segmentation

The IKONOS panchromatic image was segmented using watershed algorithm[3]. Then, the segmented regions were classified to discriminate tree crowns using the feature of spectral signature. The segmented regions were converted to octagonal shape as well as the tree crowns in the projected on-ground map.

C. Tree-to-Tree Matching

Using the positional information of the east tower by GPS equipment, we performed roughly registration of the satellite image to the on-ground map. This is initial registration. Then, using affine transformation, the projected on-ground map is translated, rotated and scaled in order to find the optimum registration. In each overlap of registration, we performed tree-to-tree matching algorithm and calculated fitness value. When the fitness value becomes the maximum, we obtain the optimum parameters of affine transformation for rectifying satellite image to the map coordinate, and identify tree crowns. Fig.5 shows the flow diagram of tree-to-tree matching.

1) *Initial Registration:* Using the positional information of the east tower, we performed roughly registration of the satellite image to map. The latitude by GPS equipment is $35^{\circ} 24' 24.24''$ north and longitude is $138^{\circ} 24' 21.26''$ east.

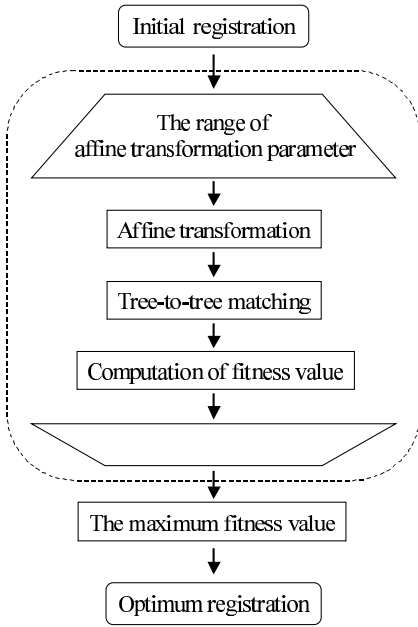

Fig. 5. Flow diagram of tree-to-tree matching.

TABLE I
THE AFFINE TRANSFORMATION PARAMETERS, RANGE AND STEP FOR SEARCH

Parameter	Range	Step
Translation: dx, dy	$-25 \leq dx, dy \leq 25$	1 meter
Rotation : θ	$-5 \leq \theta \leq 5$	0.5 degree
Scaling : s	$-0.9 \leq s \leq 1.1$	0.01

2) *Finding*: The projected on-ground crown map was overlapped to the satellite image using affine transformation. In order to find the optimum registration, we performed tree-to-tree matching and calculated fitness value in each overlap. The equation of the affine transformation is defined as:

$$\begin{pmatrix} x \\ y \end{pmatrix} = s \begin{pmatrix} \cos \theta & -\sin \theta \\ \sin \theta & \cos \theta \end{pmatrix} \begin{pmatrix} x_0 \\ y_0 \end{pmatrix} + \begin{pmatrix} dx \\ dy \end{pmatrix} \quad (1)$$

where (x_0, y_0) is the location of the east tower at initial registration. The affine parameters range of search and step size are shown in Table I.

3) *Matching*: For each tree crown in the map, we find out the same tree among segmented regions from satellite image, which has the highest corresponding possibility to the tree crown in the map. Fig.6 shows illustration of tree overlap. The degree of tree overlap is defined as:

$$OL[i][j] = \sqrt{\frac{A[i] \cap B[j]}{A[i]} \times \frac{A[i] \cap B[j]}{B[j]}} \quad (2)$$

where $A[i]\{i = 1 \dots 60\}$ is the tree crown in the projected on-ground map, and $B[j]\{j = 1 \dots N\}$ is the segmented region from satellite image. The region $B[k_i]\{k_i = 1 \dots N\}$ of the

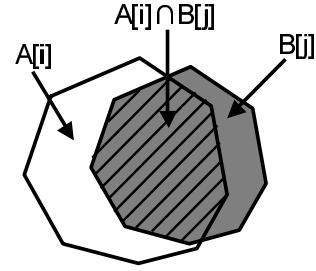

Fig. 6. The illustration of tree overlap. $A[i]$ is the tree crown in the projected on-ground map. $B[j]$ is the segmented region from satellite image.

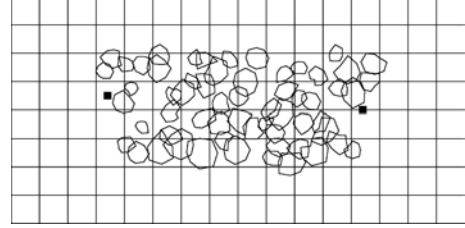

Fig. 7. The projected on-ground map of 60 canopy trees. The small squares are locations of flux towers.

highest value is defined as:

$$OL[i][k_i] \geq OL[i][j] \quad \text{for } j = 1 \dots N. \quad (3)$$

4) *Fitness value*: The tree-to-tree matching algorithm is performed using the fitness value of the location and octagonal shape of both tree crowns in the satellite image and the projected on-ground map.

The fitness value P at each overlap by affine transformation is defined as:

$$P = \frac{1}{60} \sum_{i=1}^{60} OL[i][k_i]. \quad (4)$$

When the fitness value becomes the maximum, we obtain the optimum parameters of affine transformation for rectifying satellite image to the map coordinate, and identify tree crowns.

IV. RESULTS

A. The Projected On-Ground Map

The projected on-ground map created from the measurement data of 60 canopy trees is shown in Fig.7. In this result, the small squares are flux towers.

B. Image Segmentation

Fig.8(a) shows the result of image segmentation. The number of segmented regions was 1439. The tree crowns were detected by classification. Fig.8(b) shows the 825 regions of tree crown.

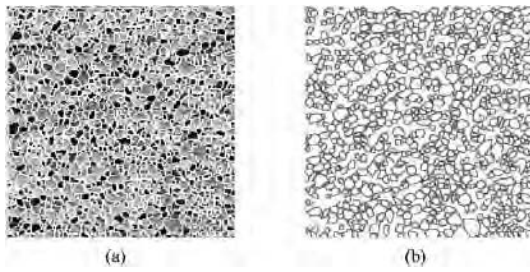

Fig. 8. (a) 1439 regions segmented from satellite image. (b) 825 regions of tree crown were detected by classification.

TABLE II
THE AFFINE TRANSFORMATION PARAMETERS AT OPTIMUM
IMAGE-TO-MAP RECTIFICATION

Translation: dx, dy	-8, 18 meter
Rotation : θ	2.5 degree
Scaling : s	0.99

C. Tree-to-Tree Matching

The affine transformation parameters at optimum image-to-map rectification is shown in Table II. The initial registration of tree-to-tree matching and the histogram of tree overlap are shown in Fig.9. The optimum registration of tree-to-tree matching and the histogram of tree overlap are shown in Fig.10. The average of the tree overlap at the optimum registration was increased from 0.4 to 0.55 compared to the initial registration. At initial registration, some tree overlap values were less than 0.1. By the optimum registration, the overlap values of all tree crowns were became more than 0.2. The locations of the towers in the projected on-ground map overlapped with the locations of the towers by visual inspection in satellite image. Using the method in this study, we obtained equivalent result with the accuracy of image registration by using ground control points. By the method in this study, the optimum registration were obtained without ground control points.

V. CONCLUSION

In this study, we proposed the method to identify tree crown from satellite image by image-to-map rectification. The tree-to-tree matching algorithm was performed using the fitness value of the location and octagonal shape of both tree crown in satellite image and field measurement map. We could obtain the optimum registration by affine transformation of highest fitness value without ground control points.

Furthermore, it became possible to obtain the spectral information such a normalized difference vegetation index (NDVI) from multi-spectral satellite data, about individual trees. This method is useful for forest management and monitoring.

ACKNOWLEDGEMENT

This research was supported in part by Grant-in-Aid for Scientific Research (C) from Japan Society for the Promotion of Science (No.18580259).

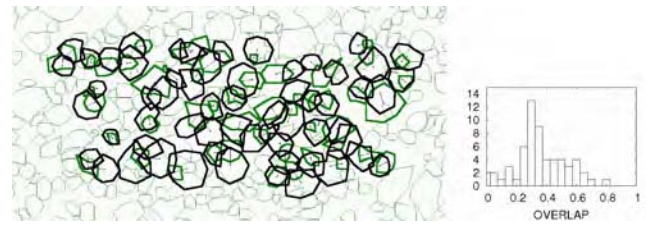

Fig. 9. The initial registration of tree-to-tree matching and the histogram of tree overlap.

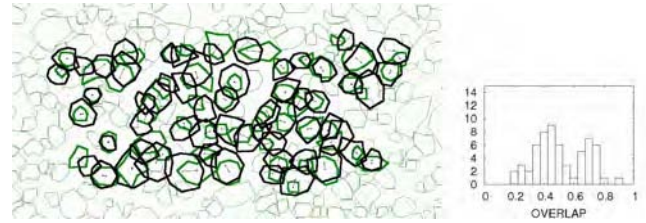

Fig. 10. The optimum registration of tree-to-tree matching and the histogram of tree overlap.

REFERENCES

- [1] F.A.Gougeon and D.G.Leckie, The individual tree crown approach applied to IKONOS images of a coniferous plantation area, *Photogrammetric Engineering & Remote Sensing*, vol.72, no.11, pp.1287-1297, 2006.
- [2] Xiaowei Yu, Juha Hyypä, Antero Kukko, Matti Maltamo, and Harri Kaatinen, Change detection techniques for canopy height growth measurements using airborne laser scanner data, *Photogrammetric Engineering & Remote Sensing*, vol.72, no.12, pp.1339-1348, 2006.
- [3] M. Kubo, K. Muramoto, Tree crown detection and classification using forest imagery by IKONOS, *Proceedings of IGARSS*, vol.6, pp.4358-4361, 2005.