

Date of publication xxxx 00, 0000, date of current version xxxx 00, 0000.

Digital Object Identifier 10.1109/ACCESS.2019.DOI

Robust and Efficient Energy Harvested-aware Routing Protocol with Clustering Approach in Body Area Networks

ZAHID ULLAH¹, IMRAN AHMED¹, TAMLEEK ALI¹, NAVEED AHMAD², Fahim Niza¹ and YUE CAO³

¹Center of Excellence in IT, Institute of Management Sciences, Peshawar, Pakistan.

²Department of Computer Sciences, University of Peshawar, Pakistan.

³School of Computing and Communications, Lancaster University, UK.

Corresponding author: Yue Cao (e-mail: yue.cao@lancaster.ac.uk)

ABSTRACT Wireless Body Area Network (WBAN) is one of the specialized branch of wireless sensor networks (WSNs), which draws attention from various fields of science, such as medicine, engineering, physics, biology, and computer science. It has emerged as an important research area contributing to sports, social welfare and medical treatment. One of the most important technologies of WBANs is the routing technology. For efficient routing in WBANs, multiple network operations such as network stability, throughput, energy efficiency, end-to-end delay and packet delivery ratio must be considered. In this research work, a robust and efficient Energy Harvested-aware Routing protocol with Clustering approach in Body area networks (EH-RCB), is proposed. It is designed with the intent to stabilize the operation of WBANs by choosing the best forwarder node, which is based on optimal calculated Cost Function (C.F). The C.F considers link SNR, required transmission power, distance between nodes and total available energy i.e. harvested energy and residual energy. Comprehensive simulation has been conducted, supported by NS-2 and C++ simulations tools to compare EH-RCB with existing protocols named as DSCB, EERP, RE-ATTEMPT, and EECBSR. The results indicate a significant improvement in EH-RCB in terms of end-to-end delay network stability, packet delivery ratio and network throughput.

INDEX TERMS Clustering, end-to-end delay, Harvesting, Network stability, packet delivery ratio, throughput, WBANs.

I. INTRODUCTION

DUE to advancement in communication technology and electronics, a newer type of network has emerged called as Wireless Body Area Networks (WBANs) which is becoming one of the prominent areas of research. It has been emerging because of its cost-effective nature, usage in wide spread applications and having the ability of remote monitoring [1]. It proposes encouraging services in different areas, such as mobile health-care, defence, industries, research and business [2].

WBANs is made up of heterogeneous wearable or implantable intelligent, small sized, low cost, low powered, light weighted invasive or non-invasive personal computing radio devices called as wireless sensor nodes. These sensor

devices operate in close proximity of human body, have the capability to sense/ observe the physiological & non-physiological parameters and then transmit it via wireless link to sink node [3]. Due to compact and small size, these sensor nodes are equipped with limited energy supply. These sensor nodes in most of the cases are non-rechargeable and non-replaceable as they are implanted inside the human body.

Nodes with limited battery energy not only imposes performance drawback, but also depletes quickly, limiting the service availability. Research efforts have been going on to develop energy efficient protocols, effective topology design and energy conservation schemes to minimize energy constraints. However, limited energy is still a critical issue that makes usage of WBANs less desirable. Addition to energy

limitation, high path-loss and short range of communication are other critical issues needed to be observed in WBANs. Furthermore, traditional routing protocols, which in most of the cases provide end-to-end communication solution, are less energy efficient. These routing protocols are not suitable for WBANs environment, due to high energy consumption in routing process. To cater this issue, the routing protocol specifically designed for WBANs that uses hop-to-hop (multi-hop) communication is recommended, because of its low energy consumption.

To cater the energy limitation issue, Energy Harvesting (EH) is another most promising approach. In this approach, a sensor node which is capable of harvesting energy, acquires energy from various sources present in surrounding environment such as body temperature, motion, vibration, ambient light etc. (as shown in Table 1) and converts it into usable energy (electrical), as described in Fig.1. EH provides a way to enhance WBANs life-time by providing a continuous energy supply to wireless sensor nodes. Still more effort is needed to make communication protocols, more optimized and energy efficient, specifically routing protocols and EH techniques, in order for it to be widely adopted. Therefore, there is a dire need of EH aware routing protocol, to optimize the operations of WBANs.

To solve the energy limitation issue and to enhance WBANs lifetime, a new scheme is proposed, namely Robust and Efficient Energy Harvested-aware Routing Protocol with Clustering Approach in Body Area Networks (EH-RCB). It mainly focuses on resolving path-loss, network life-time, end-to-end delay and packet delivery issues. In this scheme, sensor nodes are deployed at different location of the human body. In order to collect sensed data from the sensor nodes, two sink nodes are placed at the center in front and backside of the human body. Each sensor sends data to the sink using either direct communication or through intermediate forwarder node. Direct communication is done in two cases; either the sensed data is critical, or the sensor node is closer to the sink node.

- The network lifetime of WBAN can be enhanced by effectively and efficiently utilizing battery power of the sensor node and also with the use of EH mechanism. The EH helps in overcoming the energy shortage by continuously providing energy to wireless sensor node, that is generated from the surrounding environment.
- The path-loss or dis-connectivity in wireless link may occur due to frequent movement of human body. This issue is resolved by implementing an idea of using two sink nodes embedding with clustering technique. The proposed scheme uses clustering approach to enhance nodes connectivity with each other and to balance out the load on single sink node.
- Furthermore, for efficient communication, the proposed routing protocol optimizes the routing process by effectively using different parameters. To forward the sensed data from the sensor node to sink, the proposed protocol selects intermediate node (forwarder) among

the available neighbor nodes, by introducing a new kind of Cost Function (C.F). The proposed C.F is calculated using node total energy, distance from other node, link SNR and required transmission power (T.P). The used parameters in C.F, ensures efficient utilization of nodes resources to enhance the performance of WBANs.

The summarized working of the proposed protocol is briefly shown in Fig.3 and is further elaborated with detail in flowchart (shown in Fig. 9) and Algorithm 1. There are mainly five steps in the proposed protocol ie. Deployment, Initialization and Cluster formation, Cost Function calculation, Forwarder node selection and Data Transmission. Several simulation experiments are performed to evaluate the performance of proposed routing scheme. The results indicate that the proposed scheme achieves better performance in terms of residual energy, network life-time, throughput, end to end delay and packet delivery ratio as compared to some of the existing routing schemes.

This research paper is organized as follow: literature review, which comprises of some state-of-the-art techniques is presented in section II. Detailed background of WBANs is described in section III. An Overview of our proposed scheme (EH-RCB), its system model and motivation behind this works is presented in section IV. Simulation results of the proposed scheme and its comparison with other state of the art protocols are discussed in section V. Section VI concludes this research work.

II. LITERATURE REVIEW

Although lots of algorithms and schemes have been developed for conventional sensor network [7]–[13], they cannot be directly used in WBANs application due to different working environment. As evident by literature, and seen in Table 2, human body has a different wireless network environment from that of other traditional wireless networks [14]–[21]. Research can help in finding several major themes in the field of WBANs. These research themes include; device and hardware technology, application, security, MAC layer and network layer technologies. Typically, routing is one of the technologies among the core specific WBANs management technologies. Hence, researchers have proposed many routing schemes in WBANs, with the aim to maximize the network stability period, overcome path-loss issue, lower end-to-end delay and to make reliable communication. Some of those schemes are summarized below.

In [22], authors proposed Even Energy Consumption and Back Side Routing (EECBSR) protocol which is used for efficient and effective transmission of sensed data in WBANs. In this protocol, more attention is paid to uniform consumption of energy, in order to maximize network life-time and overcome the path loss problem for nodes that are attached to the backside of the human body. For this scheme, the Mobile ATTEMPT (M-ATTEMPT) protocol is analyzed and its improved scheme is proposed. The authors have claimed, based on the simulation conducted that EECBSR is a best amongst other protocol. The proposed scheme has shown

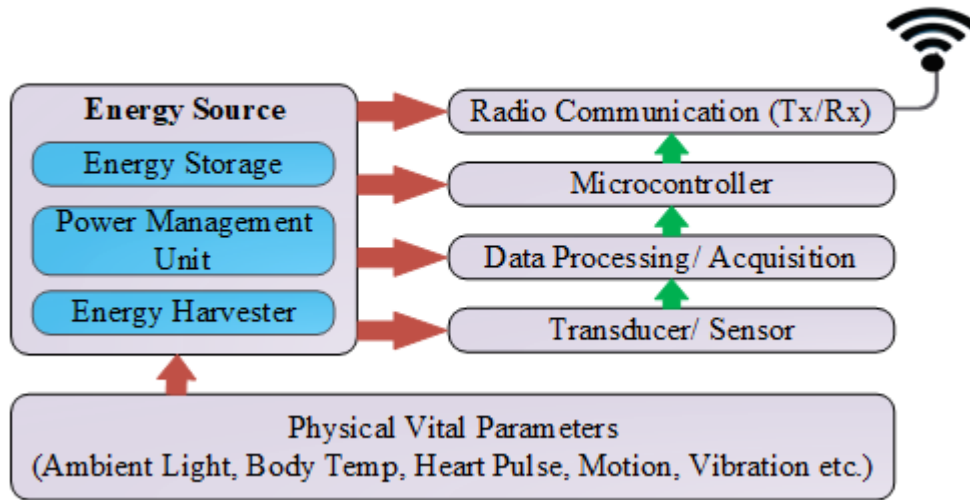

FIGURE 1. A Typical Energy Harvesting mechanism in Human Environment.

TABLE 1. VARIOUS ENERGY HARVESTING TECHNIQUES and DIFFERENT ASSOCIATED FACTORS

Energy Source [4]	Performance [5]	Sources	Nature	Transducer	Harvester Consideration	Efficiency	Nodes [6]
Ambient (Light)	100mW/cm ² (Direct Sunlight) 100uW/cm ² (Indoor & outdoor lighting)	Sun, Various indoor and outdoor lighting	Predictable but uncontrolled	Photovoltaic Cell	Light Intensity and Wavelength	10-24 percent	IRN (MicaZ) BLSH (Tmotesty) LTSN (Fleckl) HydroWatch (TelcosB) Helinote (Mica2)
Ambient (Thermal/ Heat)	60uW/cm ² at 5K gradient 135uW/cm ² at 10K gradient	Body, Sun, System losses	Fully Controllable and unpredictable	Thermo-electric element	Thermal gradient heat flux	0.1 percent 3 percent	Flex TEG wearable TEG
Bio-Mechanical vibration (Piezoelectric)	6uW/cm ³ 1.2 uW/cm ²	Blood pressure Heart beat	unpredictable and Uncontrollable	piezoelectric, Mass imbalance oscillation, electromagnetic induction, electrostatic Nano-generators	low energy and requires invasive procedure, Amplitude of vibration and resonant frequency	25-50 percent	AEM MEEG Piezoelectric MEEG
Bio-Mechanical vibration (Electromagnetic)	N/A 2mW/cm ³ /250uW/cm ²	Breathing Locomotion					Electronic MEEG
Ambient (Electromagnetic) radiation/ radio frequency)	0.1 uW/cm ² (Background) 1 mW/cm ² (Directed)	TV towers, base station, cell phones routers etc.	Partially controllable	Antennas	Distance from source and resonance of antenna	50 percent	-
Bio-chemical (Electrochemical)	0.93W at 100mmHg	Glucose, Lactate, Endo-cochlear potential	unpredictable & uncontrolled	Enzymatic biofuel cell, Endo-electronic chip	Low energy and requires invasive procedure	-	-

improved performance in terms of throughput and network stability in comparison with existing routing schemes.

The authors in [23], presented a new energy efficient routing scheme, named as NEW-ATTEMPT, which provides high bandwidth in heterogeneous WBANs. The Cost Function (C.F) is used to select the forwarder node to transmit the sensed data from the source to the destination sink node. The calculation of C.F is based on the remaining energy, the receiver distance and the data rate of the transmitter node.

Based on the experimentation results, the authors claimed that the proposed scheme is effective in terms of energy consumption and communication delay and it can be the best option for a healthcare monitoring system.

RE-ATTEMPT, [24] is another routing protocol that uses fixed deployment of sensors (nodes), based according to energy levels. This protocol uses single-hop communication for critical data delivery and hop-to-hop communication for the normal data delivery. RE-ATTEMPT protocol uses hop-

count metric to select forwarder node. The link having minimum hop-count is considered as the best path for communication.

The authors in [25] presented their hypothesis as a reliable, efficient in terms of power consumption and high stable network for WBANs. Total eight sensor nodes are used in this protocol. Two of these eight sensors are used to send critical data directly to the sink node. Other nodes use multi-hop communication by selecting forwarder node with the help of cost function. It is calculated by using distance and residual energy of the node.

Vahid et.al, presented an efficient forwarder node selection scheme for multi-hop communication in WBANs. To select next hop, the link cost function and minimum hop count are jointly used [26]. The link cost function is based on, free buffer space, residual energy of sensor node, and reliability of link with neighbor nodes. These parameters are used to meet QoS requirements with respect to end-to-end delay and to balance energy consumption. Comparative analysis with selected protocols, after extensive simulations, showed improvement in terms of data packets forwarded, energy consumption, packet delivery ratio and end-to-end delay.

New Relay based Thermal aware and Mobile Routing Protocol (RTM-RP) for WBANs is presented in [27]. It is mainly focused on to tackle the problems of high temperature and high consumption of energy. It is used in scenarios where mobility is crucial constraint to handle. In [28], Omar Smail et al. presented energy efficient, reliable and stable routing protocol for mobile WBANs. This protocol increases Lifetime of network by preserving nodes residual energy. For this purpose, an objective model is used which selects energy efficient paths that is having stable links.

Sriyanjana Adhikary et al. in [29], proposed an efficient multi-hop WBANs routing protocol. It provides efficiency in terms of improved network life-time, minimized transmission power, and packet delivery ratio. Forwarder nodes are selected based on the cost function, based on nodal transmission power, residual energy, velocity vector of receiver and node location from coordinator.

Dual Sink approach using Clustering in Body Area Network (DSCB) [30], mainly focused on network stability and path loss. DSCB protocol was developed with the aim to enhance network life-time, and to solve the path loss issue using clustering approach. In this protocol, sensor nodes are combined in two groups called as clusters with sink nodes as their cluster heads. The two sinks are placed in center on front and backside of human body. This protocol is designed in such a way that if a sensor node senses critical/emergency data, it is sent directly using single-hop communication to sink node. In case of normal data, sensor node has to choose forwarder node among nearby neighbors for multi-hop communication. This selection of forwarder node is based on cost function calculation, which uses distance from sink, residual energy, and transmission power as parameters. Extensive simulation of DSCB protocol was done using MATLAB simulator and the results are compared with existing protocols, named as

SIMPLE and DARE. The results shows better performance in terms of network stability, end to end delay and throughput.

The authors in [31], proposed Energy Harvesting Routing (EHR) protocol. It improves energy efficiency by taking EH as major factor in designing of routing protocol. The proposed scheme is divided into two parts. In first part, a hybrid routing metric is introduced, in which EH and residual energy parameters are combined, and its effects are checked. In second part, an updating mechanism is proposed, which maintain neighbor energy information dynamically. Using the neighbor information and hybrid metric, this protocol selects best next hop. Based on the simulations conducted, EHR outperforms its counterpart Energy Harvested routing schemes in terms of energy efficiency.

The authors in [32], proposed clustering based routing scheme, which is referred to as Distance and Energy-Aware Routing with Energy Reservation (DEARER). This protocol selects Cluster Head (CH) on basis of harvested energy and the distance to the sink node. It enforces other nodes (non-CH nodes) to preserve the generated energy for future use and is called as enabler nodes. CHs are selected among these enabler nodes and after the selection, these nodes are provided with more harvested energy to overcome the energy shortage issue. DEARER protocol outperforms other genie-aided and direct transmission routing protocols in terms of network stability.

An Energy aware Distributed Clustering Routing Protocol for Energy Harvesting WSNs (EDCPWSN) is proposed in [33]. For Cluster Head (CH) selection in distributed cluster routing, it uses harvested energy and residual energy in short term prediction horizon. In order to make this protocol as energy aware, a solar energy prediction model which is based on neural network is used. A node with stronger harvesting energy capability and residual energy has high probability in selecting as CH. To check for network throughput and number of alive nodes, the propose protocol is compared with LEACH protocol [34]. Simulation results depict that the proposed protocol works better in terms of balancing nodes energy consumption as compared to LEACH.

The authors in [35] propose Stability aware Geographic routing protocol for reliable data transmission in Energy Harvesting WSN (SGRP), which is based on photo voltaic model. Its main focus is on providing reliability in route selection and enhancing life-time of network. In order to achieve these goals, influence of link quality, which is also represented by rate of packet reception, is checked for network performance. This protocol outperforms its counterparts in terms of packet delivery ratio and energy consumption.

Power-Quality of Service (QoS) control scheme, called as PEH-QoS is made up of three modules [36]. In order to optimally utilize the available energy to achieve good QoS, these three modules interact with each other. This scheme makes sure that the sensor nodes efficiently sense the physiological parameters of human body and transmit it to medical server. To check this scheme for different human gestures (i.e. walking, relaxing, running, sleeping, cycling

TABLE 2. COMPARISON OF ROUTING PROTOCOL IN SENSOR NETWORKS

Protocol name	Energy Harvesting (Yes/No)	Energy efficiency (Yes/No)	Network Life-time (Yes/No)	Path-Loss (Yes/No)	Routing Metric (e.g. Temperature, cost of route.)	Delay (Very Low, Low, High and Very High)	Mobility Support (Yes/No)	Energy Consumption (Very Low, Low, High and Very High)	Scalability (Yes/No)	Network Type (Homogenous/Heterogenous)	Emergency support (Yes/ No)
EECBSR [22]	No	Yes	Yes	Yes	Small hop-count and residual energy.	Low	No	Low	No	Homogenous	No
NEW ATTEMPT [23]	No	Yes	Yes	No	Cost function based on Distance, Data rate and Residual Energy	Low	No	High	No	Homogenous	Yes
RE-ATTEMPT [24]	No	Yes	Yes	Yes	Minimum hop-count	Very Low	Yes	High	No	Homogenous	Yes
EERP [25]	No	Yes	Yes	No	Cost function based on minimum distance, and maximum residual energy.	Low	No	Low	No	Homogenous	Yes
ENSAM [26]	No	Yes	Yes	No	Small hop-count and Link cost function (freebuffer space, Residual energy and reliability of the link).	Very Low	No	Low	No	Homogenous	No
RTM-RP [27]	No	Yes	Yes	No	Energy efficient path is selected having stable link.	High	Yes	High	No	Homogenous	No
ESR [28]	No	Yes	Yes	No	Energy efficient path with stable link.	High	No	Low	No	Homogenous	No
New RP-WBAN [29]	No	Yes	Yes	No	Cost function based on Transmission power, velocity vector, location, and Residual energy.	High	No	High	No	Homogenous	No
DSCB [30]	No	Yes	Yes	Yes	Cost function based on Distance and Residual Energy.	Low	Yes	Low	No	Homogenous	Yes
EHR [31]	Yes	Yes	Yes	No	Energy harvesting, Residual energy, neighbor info and hybrid metrics to select forwarder node.	High	No	Low	No	Not Specified	No
DEARER [32]	Yes	Yes	Yes	No	Harvested energy and distance	Not Specified	No	Very Low	No	Homogenous	No
EDCPWSN [33]	Yes	Yes	Yes	No	Clustering Routing protocol based on Residual energy and Harvested energy.	Low	No	Very Low	Yes	Homogenous	No
SGRP [34]	Yes	Yes	Yes	No	Link Quality, hop-count and packet reception rate.	Low	No	Low	No	Homogenous	No
PEH-QoS [35]	Yes	Yes	Yes	No	Available energy, QoS, Delay, throughput and packet-loss	Low	No	Low	No	Not Specified	Yes
PROPOSED	Yes	Yes	Yes	Yes	Cost Function based on Transmission Power, link quality (SNR), distance, Harvested energy and Residual Energy.	Low	Yes	Very Low	Yes	Homogenous	Yes

etc.), extensive simulations have been conducted. It shows that the PEH-QoS application for medical node has high detection and energy efficiency as well as higher throughput of the system.

III. WBAN IN M-HEALTH: A BIRD EYE OVERVIEW

WBANs used for Mobile-Health (m-health) monitoring, as illustrated in Fig.2, is divided into three tier Tele-medicine system. This system is comprised of wireless body sensor network which monitors individual health parameters. Health monitoring system is further connected to medical server placed at top of the hierarchy through traditional network system (e.g. internet) [37].

A. TIER 1 (WBAN TIER)

In this Tier, each under observed individual is equipped with multiple small size wireless sensor nodes. These heterogeneous sensors are either strategically implanted or placed on the body as wearable devices. As described in Fig.2, these sensor nodes sense different body physiological parameters, such as pulse rate, blood pressure, EEG, EMG, ECG, motion, lactic acid etc.

To perform intra-WBAN Tier communication, these wireless sensor nodes uses radio waves to communicate with each other and with sink node, (which is also placed on human body). Sink node receives vital signs from sensors nodes, aggregates it and further passes this information to Personal Server (PS) through nearby access point or any other communicating device.

B. TIER 2

The second Tier is the PS tier, which is implemented in personal computer/laptop, Personal Digital Assistant (PDA) or

Mobile phone. Data gathered from sensor nodes in different formats such as graphical, digital, audio etc. are transferred to medical server using PS. It uses different technologies such as cellular mobile networks (2G-5G) or WLANs for communication with medical server placed at distant location.

C. TIER 3

It is composed of complex network of different interconnected devices, services, health-care professionals and medical service providers. This tier provides services to hundreds or even thousands of users using medical servers as central point. These servers keep medical records of individual users, and provide numerous other services to these users and other related stack holders. The responsibilities of the medical server include user authentication, acceptance and uploading of health-care related data, and its formatting, and analyzing, to recognize the seriousness of health anomalies. If the analyzed data shows that potential medical condition of the under observed individual is serious in nature, the medical server sends alarm signals to emergency care givers. The patients and their physicians can access the analyzed data at their locations via internet. The unde observed individual data is examined by the physicians to ensure that it is within expected defined health ranges (e.g. blood pressure, heartbeat rate etc.), and the prescribed or given health treatment is delivering the results.

IV. PROPOSED PROTOCOL

Robust and efficient Energy Harvested-aware Routing Protocol with Clustering approach in Body area network (EH-RCB) is proposed to address the issues of;

- Network stability, which is affected in WBANs due to limited node energy because of node small size.

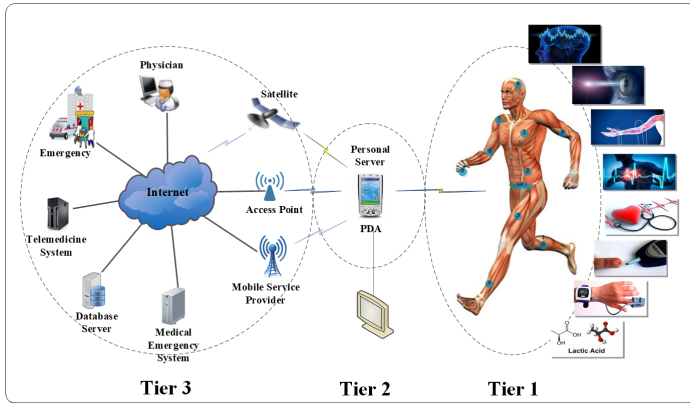

FIGURE 2. WBANs Three Tier Architecture

- Path-loss and end-to-end delay due to mobility and structure of human body.

The aim of this research is to enhance network lifetime, network stability, and communication throughput, and minimize transmission end-to-end delay. The schematic diagram of the proposed routing protocol is depicted in Fig.5, which briefly describes the working of the scheme. EH-RCB is composed of several phases, as shown in Fig.4, i.e. deployment, initialization, cluster formation, routing, time scheduling and transmission phases.

Under the general working of sensor networks, most of WBANs routing protocols follow the same schedule of working phases. In the first phase i.e. deployment, the sensors and sink nodes are deployed at their specific location in/on human body. Once all the nodes are deployed, they exchange *Hello* and *Reply* messages with each other, which comprises of different parameters, such as node location, node ID, total energy and the distance to the sink and other nodes. Based on this exchanged information, neighbor tables are created at each node, which is used in cluster formation and routing phases. During cluster formation phase, two clusters are formed with sink nodes as their respective CHs. All other sensor nodes join one of these two clusters, based on the available information. In routing phase, each node determines the path to the sink node by calculating Cost function (C.F) which uses link SNR, transmission power (T.P), location, distance (d), hop-count and total energy as parameters, which is also shown in Fig. 9 and Algorithm 1, of EH-RCP. To avoid collision on shared wireless medium, the CH assigns time-slots to each node using TDMA scheme in scheduling phase. Data transmission takes place only in assigned time-slot, whenever a node wants to send data to sink node.

A. DEPLOYMENT PHASE

In order to have a comprehensive data gathering from human body, total fourteen nodes along with two sink nodes are deployed on human body at different locations, as shown in Fig.5. For example, sink 1 is deployed in center of front

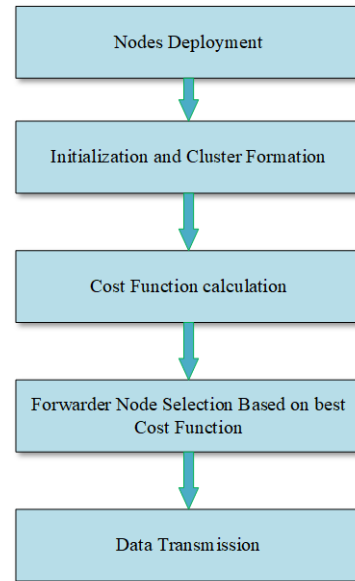

FIGURE 3. Main steps of the proposed protocol

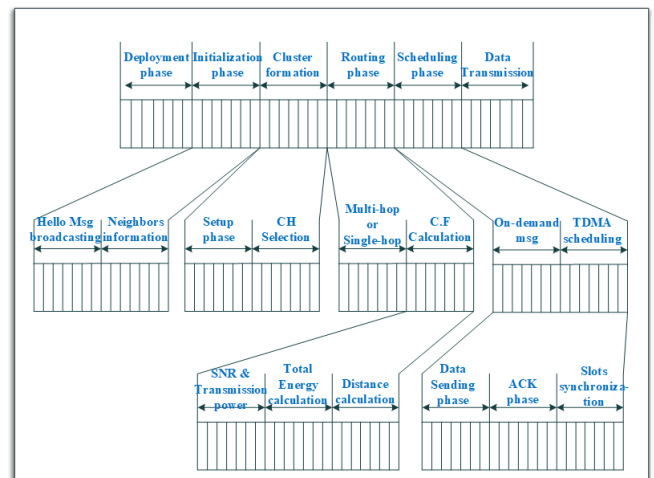

FIGURE 4. Phases of proposed routing protocol

side of human body at 0.30m and 1.01m on x-axis and y-axis respectively, which can also be seen in Table 3. To cater the energy limitation issue, and to provide a continuous energy supply from surrounding environment, each wireless sensor node is equipped with Energy Harvesting (EH) functionality. To cover the path-loss issue, both LoS and NLoS communications are addressed. Sensor node sends data only to that sink which is in its LoS. Sensed data by nodes is first checked for the criticality. If it is critical in nature, it will be sent directly to the concerned sink node. However, if it is normal data, it will follow multi-hop scenario.

TABLE 3. DESCRIPTION OF SENSOR NODES

Sensor	Description	x-axis (m)	y-axis (m)	Application Type	Power Consumption	Data Rate [15]	Bandwidth (Hz) [6], [32]
1	ECG Sensor	0.35	1.37	On-body	Low	288Kbps	100 – 1000
2	Glucose Sensor	0.38	1.01	In-body	Extremely Low	1600bps	0 – 50
3	Lactic acid Sensor	0.22	0.91	In-body	Low	400Kbps	0 – 1000
4	Pressure Sensor	0.33	0.17	On-body	Low	260Kbps	100 – 1000
5	EMG Sensor	0.07	1.09	On-body	Low	320Kbps	0 – 10,000
6	EEG Sensor	0.32	1.77	On-body	Low	43.2Kbps	0 – 150
7	Motion Sensor	0.08	1.45	On-body	High	35Kbps	0 – 500
8	EEG Sensor	0.33	1.77	On-body	Low	43.2Kbps	0 – 150
9	Pulse Oximeter Sensor	0.43	0.78	On-body	High	10 – 16Kbps	0 – 1
10	Motion Sensor	0.15	0.45	On-body	High	35Kbps	0 – 500
11	Blood Pressure Sensor	0.43	1.27	On-body	High	10 – 16bps	0 – 1
12	Respiration	0.20	1.37	On-body	Low	320Kbps	0 – 10,000
13	Glucose Sensor	0.38	1.01	In-body	Extremely Low	1600bps	0 – 50
14	Accelerometer/ Gyroscope	0.22	0.58	On-body	Low	40Kbps	0 – 500
Sink 1	Central Coordinator (front)	0.30	1.01	On-body	High	4Gbps	–
Sink 2	Central Coordinator (Back)	0.30	1.01	On-body	High	4Gbps	–

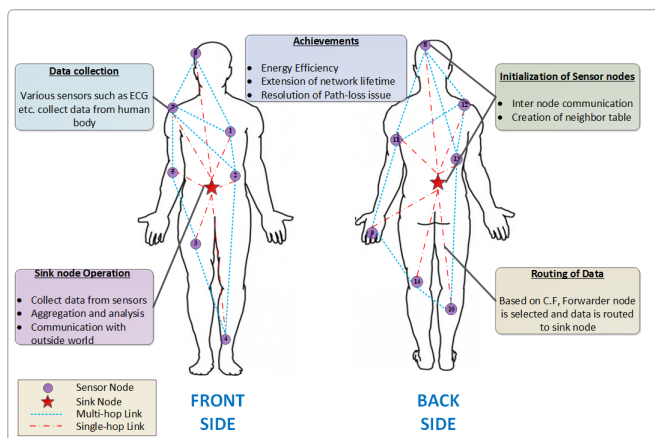

FIGURE 5. Schematic diagram of proposed scheme

B. INITIALIZATION PHASE

This phase begins by transmitting Hello messages from the two predetermined sink nodes. That is followed by Reply messages from all other sensor nodes in the network. Four main goals are achieved using these exchange of messages; each node in the network is informed completely about its (1) neighbors, (2) all possible routes leading to sink node, (3) position of the sink node, and (4) information about its respective CH. As shown in Fig. 6, each Hello packet contains source node ID ID_n , destination ID ID_{Dst} , distance d from source node n to the destination node $d(n, Dst)$ and total energy E_{Total_n} of a source node. E_{Total_n} is the combination of current residual energy $E_{Current_n}$ and Harvested energy $E_{Harvest_n}$ of a node n . The distance $d(n, Dst)$ among sensor nodes or to the sink node is calculated using Equation (1) [38].

$$d(n, Dst) = \sqrt{(X_n - X_{Dst})^2 + (Y_n - Y_{Dst})^2} \quad (1)$$

Every node keeps neighbor table, which is populated by

the data acquired after exchange of Hello and Reply packets. This information in neighbor table is used for selection of forwarder node. Every other node after reception of Hello packet, adds its own information to it and further broadcast it to its neighbors. The link is considered broken among neighbor nodes if the reply message is not received within defined time period. In this case, routing table is updated, and all related entries related to this neighbor is deleted.

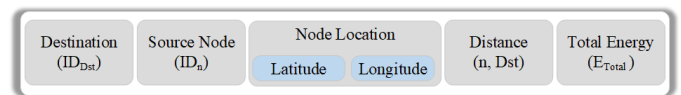

FIGURE 6. Hello and Reply Packet Format

C. CLUSTER FORMATION

In order to distribute load on single sink node and to ease the network convergence process, the wireless sensor networks are normally partitioned into different regions, called as clusters, each having its own Cluster Head (CH). Therefore, in this scheme, two clusters are formed, each having its own CH. Both sinks S1 and S2 are designated as CHs for their respective clusters as default. After designation, both CHs broadcast advertisement messages to all other sensor nodes using CSMA/CA access method in order to avoid collision in shared medium. To receive the advertisement, all sensor nodes (non-CH) must have to be in active mode. Each non-CH sensor node registers itself to one of the CH based on LoS and highest Received Signal Strength Indicator (RSSI) information that is heard in CH advertisement. If there is tie in the above two parameters, then sensor node joins the CH randomly. Both sink S1 and S2 are advanced nodes and their responsibilities as the CH is to receive the data from all sensor nodes in respective cluster, aggregate and then forward it to the access point.

D. SETUP PHASE

Once the sensor node has decided to which cluster it wants to join, it has to inform the respective CH about its cluster membership by transmitting the information back to the CH using CSMA protocol. During this process, both CH must be active by switching ON their transmission antennas.

E. SCHEDULING PHASE

Cluster formation phase is followed by scheduling phase. Once all the nodes get registered with their respective CHs, they need to be scheduled in for communication. In this phase, all sensor nodes in cluster are assigned time-slots by CH using TDMA scheduling technique. This time-slot schedule is propagated by CH to all the cluster members. There by allowing the nodes to use the same frequency band for communication based on different time-slots. In case when critical data is sensed, the sensor node is assigned a special guaranteed time-slot in Contention Free Period (CFP) from MAC super-frame. This ensure rapid delivery of critical data. For normal data delivery, nodes are assigned time-slots from Contention Access Period (CAP) in rapid succession one after the other.

F. DATA SENSING PHASE

In order to avoid the collision in shared wireless medium, each sensor node has to be in sleep mode. It is only allowed to be active for communication when its allocated time-slot is arrived. The nodes when gets active, it first checks its Total Energy E_{Total_n} , (as depicted in Equation (2)). E_{Total_n} is checked after pre-defined equal interval of time. If E_{Total_n} is found greater than defined ThresHold (T.H) value, then sensor node starts sensing else, it waits for another round. The sensed data is first checked for criticality. If the data at any point of time is found critical, then the concerned node sends it to the sink directly using single-hop communication (without any further checking), else data is sent to sink node through forwarder node using multi-hop scenario.

$$E_{Total_n} = E_{Current_n} + E_{Harvest_n} \quad (2)$$

The node residual/ current energy $E_{Current_n}$ at time t after setup the period P_{Setup} , can be expressed in Equation (3).

$$E_{Current_n^j}(t + P_{setup}) = E_{Current_n^j}(t) - E_{round_n^j}(t) + E_{Harvest_n^j}(t, P_{setup}) \quad (3)$$

$$0 < E_{Harvest_n^j}(x) < E_{Max_i}$$

Where E_{Max_i} is the node total battery capacity, $E_{round_n^j}(t)$ is the energy consumed during setup period P_{setup} round; and $E_{Harvest_n^j}(t, P_{setup})$ is the energy harvested during setup period P_{setup} . Initial energy $E_{Initial_n}$ is defined in initialization of the node before deployment phase is started.

G. ENERGY CONSUMPTION MODEL

There are various radio communication models that are proposed in literature [39], [40]. But due to simplicity in nature and relevance to our proposed work, we therefore, use first

order radio model [39], as shown in Fig.7.

The estimated total energy consumption $E_{Consume}$ in amplification, reception, aggregation and data transmission by any sensor node is calculated using Equation (4).

$$E_{Consume} = E_{Transmit} + E_{Receive} + E_{Circuit} \quad (4)$$

Where $E_{Transmit}$ and $E_{Receive}$ is the amount of energy consumed during data transmission and reception respectively and $E_{Circuit}$ is the consumed energy by the electric circuitry of a node. The energy consumption by a node n_i^j in setup period P_{setup} , starting at time t , in a round period is represented by Equations (5) and (6) as under;

$$E_{round_n^j}(t) = \int_t^{(t+P_{setup})} E_{Consume_n^j}(\Gamma) d\Gamma \quad (5)$$

$$E_{round_n^j}(t) = \int_t^{(t+P_{setup})} E_{Transmit_n^j}(\Gamma) + E_{Receive_n^j}(\Gamma) + E_{Circuit_n^j}(\Gamma) d\Gamma \quad (6)$$

To determine the expected required energy consumption for the data transmission and reception, the expression is shown in Equations (7), (8) and (9).

$$E_{Transmit}(k, d) = E_{Tx-circuit} * k + E_{Transmit-amp}(k, d) \quad (7)$$

$$E_{Transmit}(k, d) = E_{Tx-circuit} * k + \epsilon_{amp} kd^2 \quad (8)$$

$$E_{Receive}(k) = E_{Rx-circuit} * k \quad (9)$$

The distance between receiver and transmitter is represented by d . $E_{Receive}$ and $E_{Transmit}$ are the energy consumption for a packet length of k by the receiver and transmitter, respectively. Similarly, $E_{Rx-circuit}$ and $E_{Tx-circuit}$ are the per bit energy consumption by the receiver and transmitter circuitries, respectively. The type of radio amplifier is represented by ϵ_{amp} . As loss co-efficient l , is different for terrestrial wireless networks as compared to human body, so therefore Equation (8) can be rewritten in terms of l in Equation (10).

$$E_{Transmit}(k, d, l) = E_{Tx-circuit}k + \epsilon_{amp} nkd^l \quad (10)$$

Keeping in view the values of the above-mentioned parameters, receiving data is also a high cost operation. Therefore, the protocol in use should not only be focused on reducing the transmission power but also on minimizing the number of transmission and reception operation for every message.

H. ENERGY ANALYSIS FOR DIRECT AND MULTI-HOP COMMUNICATION

In WBANs, sensor nodes either use single-hop (direct) or multi-hop communication, which is based on nature of the scenario. If the distance between sensor node and the sink is greater, then single-hop transmission will consume more energy which result in early death of the node. This is only acceptable in case if either sink node is closer to the

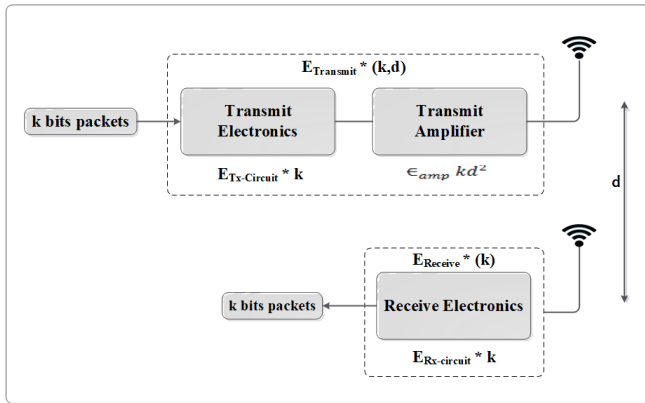

FIGURE 7. First order radio model [38]

transmitting node or data to receive is large enough for other normal nodes. In case of multi-hop communication, sensor nodes send data to sink through intermediate nodes. The data goes through n transmits and n receives which consume less energy as compare to single-hop communication. Depending on the relative costs of the radio circuitry and transmitting amplifier, the total energy of the whole system might be larger in multi-hop as compare to direct communication transmission to the sink node [18]. To understand this point, a linear network is shown in Fig.8.

The energy consumption of a node n in single-hop communication E_{Direct} while sending single k bit message with a total distance from node n to sink nr using Equations (7) to (9), is shown in Equations (11) to (13). The distance between the nodes is represented by r .

$$E_{Direct} = E_{Transmit}(k, d) \quad (11)$$

$$E_{Direct} = E_{Transmit}(k, d = n * r) \quad (12)$$

$$E_{Direct} = E_{Tx-circuit}(k) + \epsilon_{amp} * k * (nr)^2$$

$$E_{Direct} = k(E_{Tx-circuit} + \epsilon_{amp} * n^2 * r^2) \quad (13)$$

In multi-hop communication $E_{Multi-hop}$, as shown in Equations (14) to (17), every node sends the data to the nearest intermediate node while going to sink node. Thus, the node located at a distance nr from the sink node will require n transmits and $n - 1$ receives.

$$E_{Multi-hop} = n * E_{Transmit}(k, d = r) + (n - 1) * E_{Receive}(k) \quad (14)$$

$$E_{Multi-hop} = n(E_{Tx-circuit} * k + \epsilon_{amp} * k * r^2) + (n - 1) * E_{Tx-circuit} * k \quad (15)$$

$$E_{Multi-hop} = k((2n - 1)E_{Tx-circuit} + \epsilon_{amp} * nr^2) \quad (16)$$

Moreover, under the simplest definition;

$$E_{Transmit} = E_{Receive} \quad (17)$$

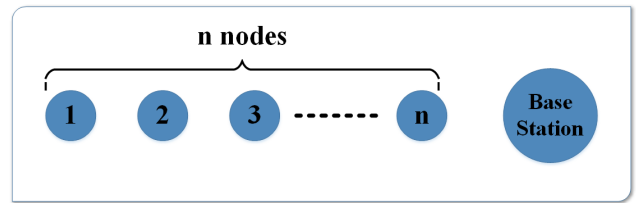

FIGURE 8. Simple Linear Sensor Network

I. ENERGY-HARVESTING MODEL

The estimated energy harvested $E_{Harvest_n}$ by a node n in a defined time period can be expressed in Equation (18) below, where the charging rate of node n in time Γ is represented by $\lambda_i(\Gamma)$.

$$E_{Harvest_n}(t, P_{Setup}) = \int_t^{(t+P_{Setup})} \lambda_i(\Gamma) d\Gamma \quad (18)$$

J. FORWARDER NODE SELECTION

In case the sensed data is normal, then number of hops towards the sink node is counted as also shown in flowchart (Fig. 9). If it is greater than zero, further steps towards forwarder selection are taken. Else node considers itself as directly connected to the sink and transmits the data directly. For multi-hop communication, node from its neighbor table is selected randomly. It checks that whether this neighbor node is previously rejected in the same round. If not, the SNR of the link is calculated. The node is rejected if its SNR is less than 1. This node information is recorded, and process is started again, else next steps are taken.

K. SNR CALCULATION

SNR is defined as the ratio of the power of environmental noise (unwanted signal) to the power of a useful signal (meaningful information), and is expressed in Equation (19).

$$SNR = \frac{P_{Signal}}{P_{Noise}} \quad (19)$$

Signals are also expressed using logarithmic decibels scale, because many of them have very wide dynamic range. Noise and signals, using the definition of decibels dB can be expressed in Equations (20) to (23);

$$P_{Signal,dB} = 10 \log_{10}(P_{Signal}) \quad (20)$$

And

$$P_{noise,dB} = 10 \log_{10}(P_{Noise}) \quad (21)$$

SNR can also be represented in decibels, as

$$SNR_{dB} = 10 \log_{10}(SNR) \quad (22)$$

While using Equation (19), we get,

$$SNR_{dB} = 10 \log_{10}(P_{Signal}/P_{Noise}) \quad (23)$$

L. COST FUNCTION COMPUTATION

Three different parameters are calculated which is further used in Cost Function (C.F) calculation as shown in Equation (25).

- 1) Transmission power ($T.P$) required in data transmission to the neighbor node as shown in Equation (24).

$$T.P = \frac{SNR}{\alpha} \quad (24)$$

("α" means path-loss exponent)

- 2) Neighbor node distance d , which is acquired using Equation (1).
- 3) Neighbor Total Energy E_{Total_n} is calculated, as described in Equation (2).

Total Energy E_{Total_n} is checked against defined energy ThresHold value (T.H). If E_{Total_n} is less than the $T.H$ value, this neighbor node is rejected to become forwarder node in this current round and its information is recorded. But if E_{Total_n} of this neighbor node is greater than $T.H$ value, then its $C.F$ is calculated.

$$C.F = \frac{E_{Total_n}}{d(n, Dst)} * T.P \quad (25)$$

Where $d(n, Dst)$ is the distance of the node from the sink, E_{Total_n} is the total energy of the node and $T.P$ is the transmission power required to send data from the node to the sink on the channel. After neighbor $C.F$ calculation, it is recorded and then it is checked whether this node is last node from neighbor table. If not, another node from neighbor table is selected and the whole process is repeated else neighbor with maximum $C.F$ is selected as forwarder. Data is forwarded to this newly selected forwarder node.

M. PATH LOSS MODEL

The quality of communication in WBANs is strongly influenced by path-loss. It occurs due to different impairments present in the human surroundings. One of the main causes of impairment is due to factor that the sensor nodes are implanted inside human body, which causes degrading in wireless communication. In case when two sensor nodes are in NLoS, the human body can cause power density reduction of electro-magnetic wave used by sensor node for communication. Reflection, refraction, absorption attenuation, distance between nodes, moist and dry air, rural and urban environment etc. are other factors which causes free space impairments in signal.

The model for Path loss (in dB) between receiving and transmitting sensor nodes in total distance d is expressed in Equation (26) [41], [42].

$$PL(d) = PL(d_0) + 10\alpha \log_{10}\left(\frac{d}{d_0}\right) + \sigma_s \quad (26)$$

Where, $PL(d_0)$ is the path-loss (in dB) at a distance d , using shadowing factor σ_s and path-loss exponent α . As Path-loss is dependent on frequency as well as distance, therefore it can be expressed in Equations (27) and (28).

$$PL_0 = 10\log_{10}\left(\frac{4d}{\lambda}\right)^2 \quad (27)$$

As $\lambda = \frac{c}{f}$, therefore Equation (27) can be rewritten as Equation (28) below.

$$PL_0 = 10\log_{10}\left(\frac{4\pi df}{c}\right)^2 \quad (28)$$

Wavelength is represented by λ , frequency of the propagating wave is denoted by f , L is the path loss in decibels, c is the speed of light and d specifies distance between receiver and transmitter.

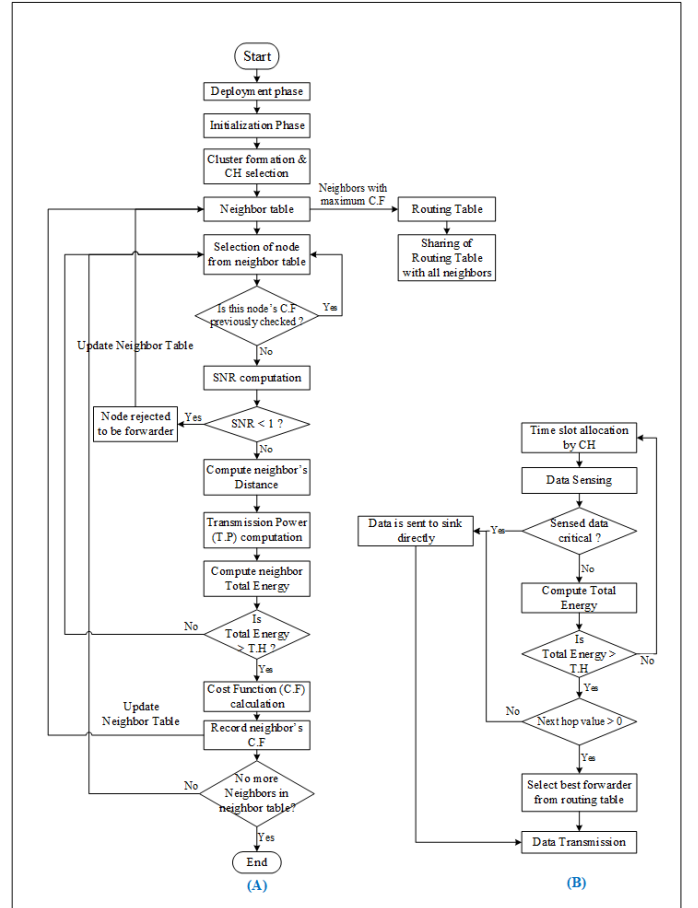

FIGURE 9. (A) Routing Flowchart (B) Data Transmission Flowchart

V. PERFORMANCE EVALUATION OF PROPOSED METHOD

To evaluate the performance of the proposed protocol, simulations in NS-2 and C++ are performed with different parameters. The acquired results of the proposed protocol are compared with some state-of-the-art protocols, namely DSCB [30], EERP [25], RE-ATTEMPT [24], and EECBSR [22], [25]. The comparisons are based on network stability, throughput, end-to-end delay and packet drop ratio. The WBAN topology used for proposed protocol as shown in Fig.5, depicts wirelessly networked wearable and implanted sensors

Algorithm 1 Algorithm for EH-RCP

```

1: Deployment Phase:
2: All nodes are deployed on human body at specified locations
3: Initialization Phase:
4: All nodes broadcast hello message
5: All nodes update their neighbors and routes to the sink information
6: Cluster Formation phase:
7: Based on the shared information two clusters are formed with pre-
   defined sink as Cluster Heads
8:  $N = [N_1, N_2, \dots, N_i]$  : //all nodes that send data to sink
9: Data sensing and Routing Phase:
10: if ( $N_i \neq$  normal data) then
11:   if ( $N_i E_{Total_n} > T.H$ ) then
12:     if ( $N_i$  Next-hop count value  $> 0$ ) then
13:       //Selection of Best forwarder node
14:       Select any neighbor node  $N_i$  from neighbor table
15:       if ( $N_i C.F$  bit = 1) then
16:         //C.F previously checked = 1, not checked = 0
17:         Select another neighbor node  $N_i$  from neighbor table
18:       else
19:         Compute  $SNR$  and ensure that it is higher than 1
20:         Compute Neighbor Distance  $d$ 
21:         Compute required Transmission Power  $T.P$ 
22:         Compute Neighbor  $E_{Total_n}$  :
23:         //( $E_{Total_n} = E_{Current_n} + E_{Harvest_n}$ )
24:         if ( $N_i E_{Total_n} < T.H$ ) then
25:           Select another neighbor node  $N_i$  from neighbor table
26:         else
27:           Calculate  $C.F$  of  $N_i$ 
28:           Record  $C.F$  and Update Neighbor Table
29:           Ensure all neighbors are checked
30:         else
31:           Send the data in single-hop to sink
32:         else
33:           Abort sending data and wait for another time.
34:         else
35:           Send the data in single-hop to sink
36:         end if
37:       end if
38:     end if
39:   end if
40: end if

```

that are placed on/inside the human body at different locations. These sensor nodes monitor human body physiological parameters such as Heart-rate, glucose level, blood pressure, motion, pressure etc. As shown in Fig.5 and Table 3, total fourteen sensor nodes are placed/implanted on human body. Each sensor is equipped with 0.8 Joule (J) of initial energy $E_{Current_n}$ along with integrated energy harvesting capability as shown in Table 4. The packet length for communication is set to 2000 bits.

A. NETWORK LIFE-TIME

Network lifetime represents the total operational time of the network, from the initialization point to death of last node. The network life-time depends upon the life of the used sensors. In Fig.10, the comparison of the proposed scheme with the existing protocols DSCB, EERP, RE-ATTEMPT, and EECBSR is done in terms of dead nodes with respect to rounds. It can be observed in Fig.10 and Table 5, that the first node of the proposed node dies at 4950th round, which is more than all other compared schemes. Similarly, the last nodes of all other schemes die at maximum of 10,000th round, whereas the last node of the proposed scheme dies af-

TABLE 4. PARAMETERS FOR SIMULATION OF THE PROPOSED PROTOCOL WITH THEIR VALES

PARAMETERS	VALUES
Simulation Area	2x2 m
Number of Sensor nodes	14 + 2 (sink nodes)
Positions of sensor nodes and sinks	Shown in Table 3
$E_{initial}$	0.8 J
$E_{Tx-Circuit}$	16.7 nJ/bit
$E_{Rx-Circuit}$	36.1 nJ/bit
$E_{Transmit-amp}$	1.97 e-9 j/b
Transmission DC current	10.5 mA
Reception DC current	17.5 mA
Wavelength (λ)	0.138 m
Frequency	2.4 GHz
Payload	2000bits

ter 12000th round. So, it can be concluded that the proposed protocol has higher network stability than other protocols. Improved performance of the proposed protocol in network stability period is due to the use of:

- 1) Energy harvesting scheme; as energy is continuously generated and is given to sensor node for its operation.
- 2) Two sink nodes, which gives the nodes an additional option to connect itself to one of the nearest sinks available and send the data. The placement of the sink in center of human body also helps other nodes, which able them for LOS communication

These two factors help in improving the performance of proposed protocol in extending network stability period to more than 12,000 rounds.

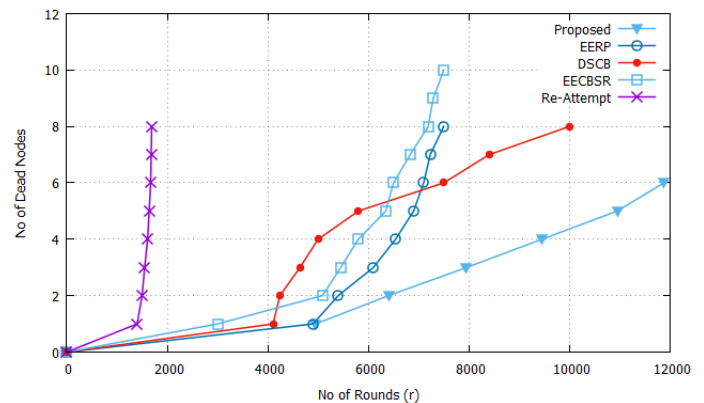
**FIGURE 10.** Average rate of dead sensors nodes vs. time**B. RESIDUAL ENERGY**

It is described as the sum of current/ remaining energy of the sensor node at any point of time/ round. In order to have extended network life-time, each node in the network has to work efficiently to minimize the energy consumption. Fig.11 shows the comparison of the proposed protocol with

TABLE 5. NUMBER OF DEAD NODES AT DIFFERENT INTERVAL OF TIME

S.No	Protocol Name	1st Node die at (rounds)	Number of dead nodes at different number of rounds (r)					
			1000r	2500r	5000r	7500r	10000r	12000r
1	Proposed	4950	0	0	1	2	4	6
2	DSCB	4105	0	0	4	6	8	8
3	EERP	4900	0	0	1	8	8	8
4	EECBSR	3000	0	0	1	10	10	10
5	Re-ATTEMPT	1400	0	8	8	8	8	8

DSCB, EERP, RE-ATTEMPT, and EECBSR based on average residual /remaining energy. It can be seen in Table 6, that the proposed protocol has overall maximum residual energy at different time interval with the exception in initial rounds. As it can also be seen in Fig.11, that more energy is consumed in initial stages due to intense calculation process of cost functions to select best forwarder node and best path. The energy consumption in proposed protocol, gets stable in later rounds as calculation of C.F is not needed, due to fully convergence of the network after some time. The energy consumption of other compared protocols is not stable; therefore, their sensor nodes die in quick session.

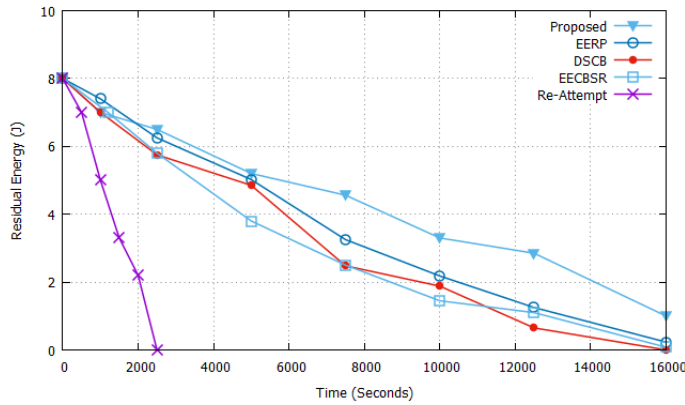

FIGURE 11. Comparison of residual energy vs. time

TABLE 6. CONSUMED ENERGY AT DIFFERENT INTERVAL OF TIME

S.No	Protocol Name	Energy (Joule) after different interval of time						
		0s	2500s	5000s	7500s	10000s	12500s	16000s
1	Proposed	8 J	6.5 J	5.20 J	4.56 J	3.30 J	2.85 J	1.0 J
2	DSCB	8 J	5.75 J	4.85 J	2.48 J	1.88 J	0.65 J	0.0 J
3	EERP	8 J	6.25 J	5.02 J	3.25 J	2.18 J	1.25 J	0.23 J
4	EECBSR	8 J	5.8 J	3.8 J	2.5 J	1.45 J	1.10 J	0.08 J
5	Re-ATTEMPT	8 J	0.0 J	0.0 J	0.0 J	0.0 J	0.0 J	0.0 J

C. END TO END DELAY

It is defined as the time lag between the transmitter and receiver node. Minimization of delay in communication is

an important and crucial factor in order to enhance network performance. As WBANs is normally used in human health-care applications, where on-time data delivery is of utmost importance. In many cases, the sensor nodes senses critical data, so it must be communicated to health care-givers on time without any delay. Keeping in view these factors, the proposed protocol is designed in such a way that it focuses on reducing the delay in the network. Simulation results as shown in Fig.12 and Table 7, attest that initially the proposed protocols performance is not significantly better in comparison with DSCB, EERP, RE-ATTEMPT, and EECBSR. The main reason for high end-to-end delay in proposed protocol at initial rounds is due to intense calculation of C.F and parameters used in it such as link SNR, distance, total energy, transmission power etc. As shown in Fig.12, the delay in proposed protocol is gradually decreased with time, because in later rounds the calculated information from earlier rounds is used and no further calculation is done which enhances the overall network performance. One of the other factors which enhances the network performance is due to the presence of two sink nodes. This enables the nodes for possible direct communication with each other, which in most cases, lessen the distance that results in low end-to-end delay. Further, the introduction of clustering mechanism helps in reducing burden on sink node. As it gathers data only from its cluster nodes.

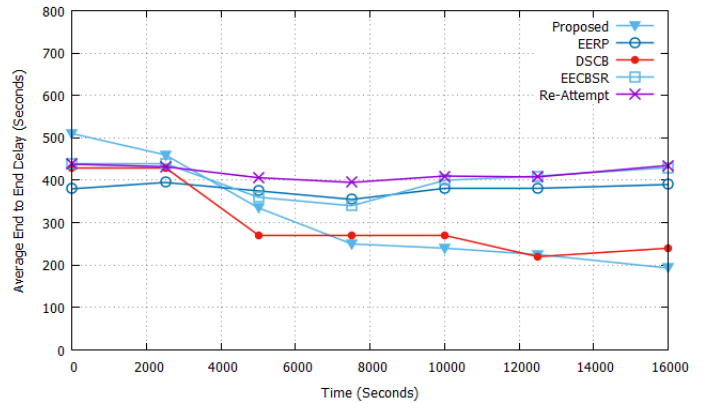

FIGURE 12. Comparison of End-to-End delay vs. time

TABLE 7. END-TO-END DELAY OF THE NETWORK

S.No	Protocol Name	Delay at time 0s	Delay after different interval of time (in milli seconds)					
			2500	7500	10000	10000	12500	16000
1	Proposed	510ms	460	335	250	240	225	193
2	DSCB	430ms	430	270	270	270	220	240
3	EERP	380ms	395	375	355	380	380	390
4	EECBSR	440ms	440	360	340	400	410	430
5	Re-ATTEMPT	438ms	432	406	395	410	408	435

D. THROUGHPUT

It is referred to as successful data packets delivery from the sensor node to sink in unit time. Normally there are two types of communication links used in WBANs which are; the link between the sensor and intermediate node and the link between intermediate node and sink. The link that connects sensor node and sink, called as direct link, can carry more data as compare to the link that connects two sensor nodes. In order to achieve high throughput, the communication protocol is designed in such a way that maximizes the use of direct link. In Proposed scheme, high throughput is achieved by deploying two sink nodes which increase the chances of direct communication from sensor node to the sink. Simulation results shown in Fig.13, shows that proposed scheme performs well in terms of throughput as compare to other protocols mentioned. It can also be viewed in the Table 8, that throughput of the proposed protocol is increased gradually with respect to time as compare to DSCB, EERP, RE-ATTEMPT, and EECBSR. Initially the throughput of the proposed protocol is almost similar to other protocols but in later stages the difference is increased, i.e. the proposed protocol achieves 45223 bytes of throughput that is higher than rest of the compared protocols.

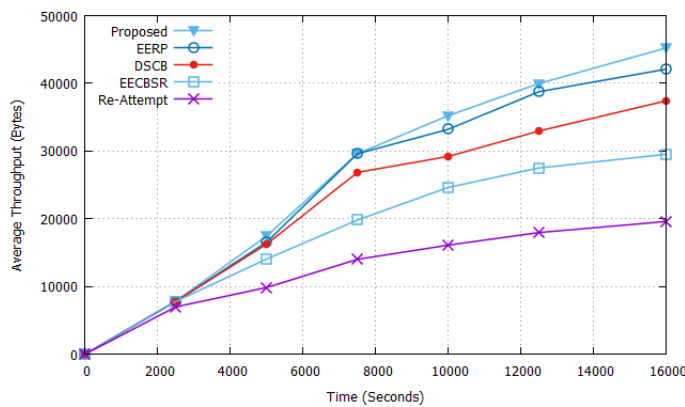

FIGURE 13. Average Network throughput vs. time

TABLE 8. NETWORK THROUGHPUT AT DIFFERENT INTERVAL OF TIME

S.No	Protocol Name	Throughput (packets sent to sink node)at various interval of time(s)						
		1000	2500	5000	7500	10000	12500	16000
1	Proposed	4600	7834	17455	29600	35220	39980	45223
2	DSCB	4590	7795	16251	26844	29198	32959	37417
3	EERP	4602	7798	16555	29600	33198	38761	42087
4	EECBSR	4598	7795	14051	19804	24618	27490	29520
5	Re-ATTEMPT	4520	6980	9840	14002	16100	17952	19592

E. PACKET DROP RATIO

Packet drop/ loss occurs when one or more packets of data travelling across a communication network fail to reach its destination. It is either caused by path-loss or congestion

in network or errors in data transmission system, typically across wireless networks. Simulation results shown in Fig.14 and Table 9, indicates that the proposed protocol has less packet drop ratio (PDR) as compare to DSCB, EERP, RE-ATTEMPT, and EECBSR. It can be viewed, that the PDR of the proposed protocol is 2.90 percent which is high from all other compared protocols except EECBSR whose packet drop ratio (PDR) is 3.18 percent. This initial worst performance is due to the rigorous process involved in network establishment and its convergence. As the network gets stable in later rounds, the PDR of the proposed protocol minimizes as compare to other protocols. The reason behind this better performance of proposed protocol in later rounds is, proper scheduling of data, i.e. normal data transmission is done in Contention Access Period (CAP) and whereas emergency data transmission in Contention Free Period (CFP) of MAC super-frame.

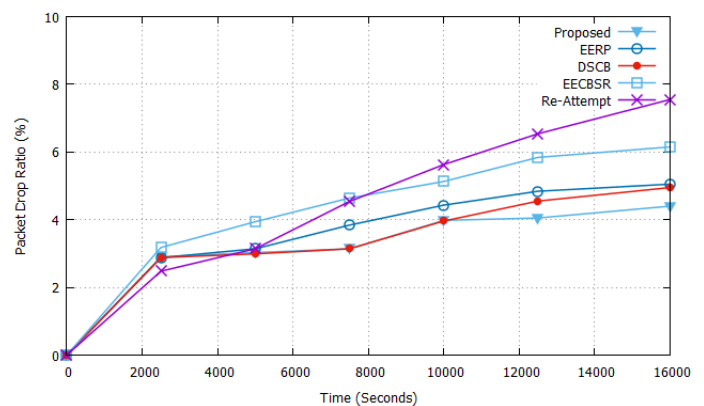

FIGURE 14. Packets drop ratio with respect to time

TABLE 9. PACKETS DROP RATIO AT DIFFERENT INTERVAL OF TIME

S.No	Protocol Name	Percentage of packets dropped at different interval of time)					
		2500s	5000s	7500s	10000s	12500s	16000s
1	Proposed	2.90	3.03	3.14	3.98	4.05	4.40
2	DSCB	2.88	2.99	3.14	3.96	4.55	4.95
3	EERP	2.88	3.14	3.84	4.43	4.84	5.05
4	EECBSR	3.18	3.94	4.64	5.13	5.84	6.15
5	Re-ATTEMPT	2.48	3.14	4.54	5.63	6.54	7.55

F. ENERGY GENERATION AND CONSUMPTION ANALYSIS

The average energy generation and consumption (in micro-Joules) of sensor nodes in four different modes i.e. receiving, idle, transmission and sleep during four different activities i.e. Running, Walking, Cycling and relaxing is shown in Fig. 15-21. Out of total fourteen sensor nodes used in the WBAN topology, only eight sensor nodes are selected randomly. The aim of simulating the proposed protocol and to acquire these results is to get in insight view of the overall network perfor-

mance. After analyzing the results, it is concluded, that more average energy is generated in harvesting process by nodes in idle mode during cycling activity, whereas less energy is generated in receiving mode during relaxing activity. This shows that, due to more movement of human body during less intense mode (i.e. sleep) more energy is harvested. Similarly, the average energy consumption is high in transmission mode during cycling activity and is less in sleep mode during relaxing activity.

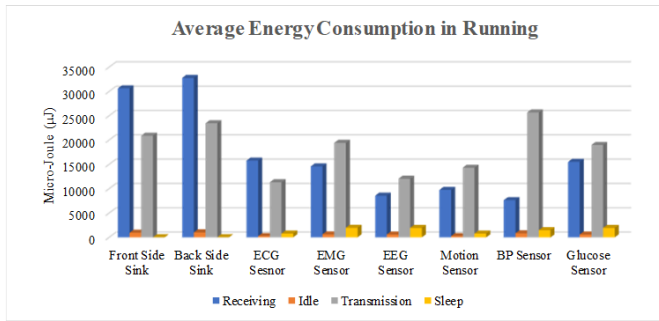

FIGURE 15. Average Energy Consumption during running

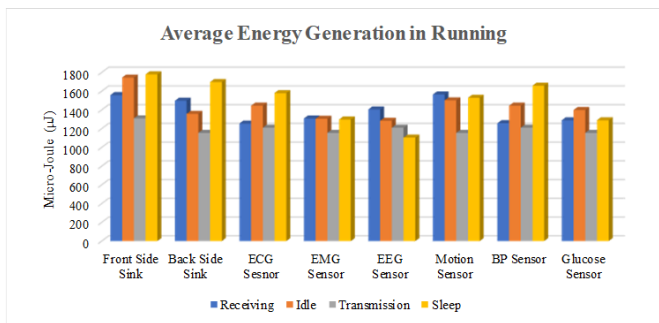

FIGURE 16. Average Energy generation during running.

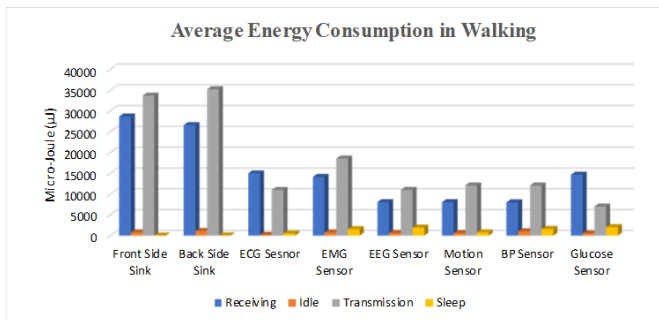

FIGURE 17. Average Energy Consumption during Walking.

VI. CONCLUSION

In this paper we have presented an Energy Efficient routing protocol for WBANs which uses Energy Harvesting (EH)

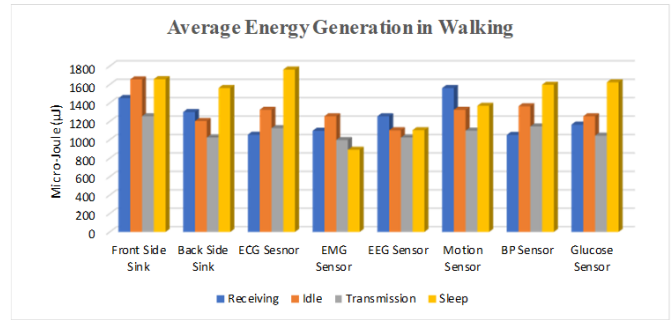

FIGURE 18. Average Energy generation during Walking

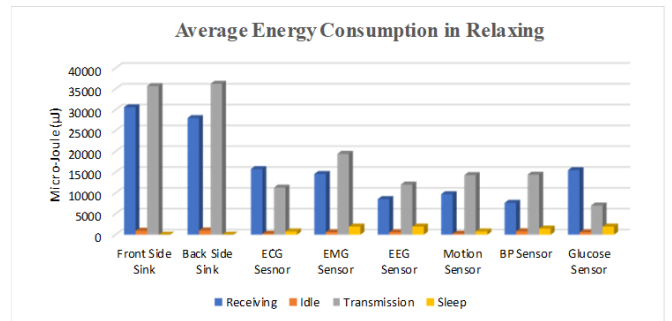

FIGURE 19. Average Energy Consumption during Relaxing.

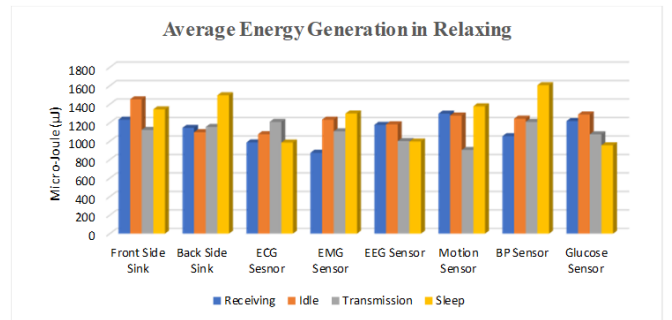

FIGURE 20. Average Energy generation during Relaxing

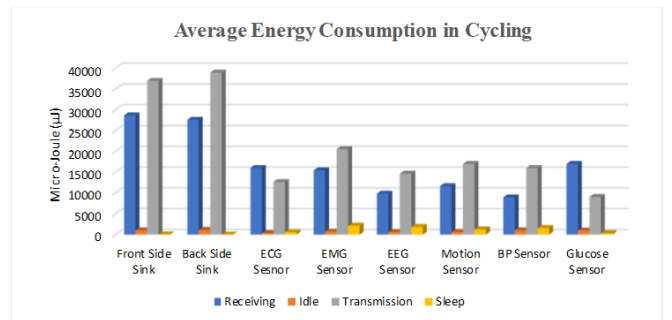

FIGURE 21. Average Energy Consumption during Cycling.

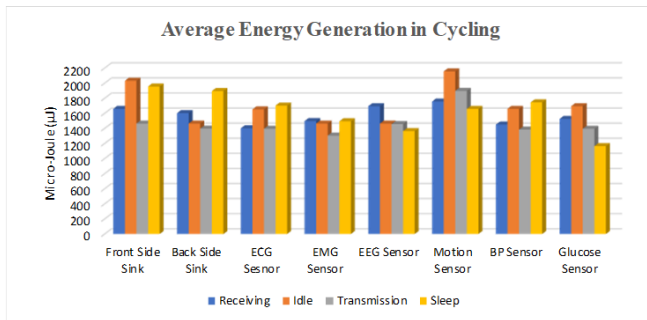

FIGURE 22. Average Energy generation during Cycling

mechanism along with clustering algorithm with dual sinks. In this protocol, we have used two sink nodes and fourteen sensor nodes on the human body. Our focus was to increase network life-time; therefore, we have used energy harvesting mechanism. Further we aimed to cover LoS and NLoS communication, therefore we used two sink nodes. Clustering approach is used to avoid the congestion on a single sink node, as only defined and limited nodes sends data to the designated sink node. The proposed protocol selects the best forwarder node for each node based on optimal calculated C.F that considers link SNR, required transmission power, distance and total available energy (i.e. harvested energy and residual energy). We have evaluated the performance of our proposed protocol on different parameters using NS-2 and C++. The results indicate that, the proposed protocol achieves lower energy consumption, minimum end-to-end delay, higher throughput, higher packet delivery ratio and ultimately higher network life-time than the DSCB, EERP, RE-ATTEMPT, and EECBSR protocol. Our future directions are focused on more energy efficiency and lower Bit Error ratio (BER) with nodes cooperation for efficient routing. As WBANs are application driven technology, our aim is to implement the presented protocol in any practical application.

REFERENCES

- [1] G. V. Crosby, C. A. Chin, T. Ghosh, and R. Murimi, "Wireless Body Area Networks in mHealth," in *Mobile Health*, ed: Springer, 2015, pp. 873-915.
- [2] S. Adibi, *Mobile health: a technology road map* vol. 5: Springer, 2015.
- [3] A. Muthulakshmi and K. Shyamala, "Efficient patient care through wireless body area networks—enhanced technique for handling emergency situations with better quality of service," *Wireless Personal Communications*, vol. 95, pp. 3755-3769, 2017.
- [4] F. Akhtar and M. H. Rehmani, "Energy Harvesting for Self-Sustainable Wireless Body Area Networks," *IT Professional*, vol. 19, pp. 32-40, 2017.
- [5] Movassaghi, Samaneh, Mehran Abolhasan, Justin Lipman, David Smith, and Abbas Jamalipour. "Wireless body area networks: A survey.", *IEEE Communications Surveys and Tutorials* 16, no. 3 (2014): 1658-1686.
- [6] F. K. Shaikh and S. Zeadally, "Energy harvesting in wireless sensor networks: A comprehensive review," *Renewable and Sustainable Energy Reviews*, vol. 55, pp. 1041-1054, 2016.
- [7] M. Khalid, Z. Ullah, N. Ahmad, M. Arshad, B. Jan, Y. Cao, et al., "A Survey of Routing Issues and Associated Protocols in Underwater Wireless Sensor Networks," *Journal of Sensors*, vol. 2017, 2017.
- [8] M. Amin, M. Abrar, Z. U. Khan, and R. Andusalam, "Comparison of OLSR and DYMO routing protocols on the basis of different performance metrics in mobile ad-hoc networks", *American Journal of Scientific Research*, pp. 34-57, 2011
- [9] M. Khalid, Z. Ullah, N. Ahmad, A. Adnan, W. Khalid, and A. Ashfaq, "Comparison of Localization Free Routing Protocols in Underwater Wireless Sensor Networks," *INTERNATIONAL JOURNAL OF ADVANCED COMPUTER SCIENCE AND APPLICATIONS*, vol. 8, pp. 408-414, 2017.
- [10] M. Khalid, Z. Ullah, N. Ahmad, H. Khan, H. S. Cruickshank, and O. U. Khan, "A comparative simulation based analysis of location based routing protocols in underwater wireless sensor networks," in *Recent Trends in Telecommunications Research (RTTR)*, Workshop on, 2017, pp. 1-5.
- [11] W. Khalid, Z. Ullah, N. Ahmed, Y. Cao, M. Khalid, M. Arshad, et al., "A taxonomy on misbehaving nodes in delay tolerant networks," *computers and security*, vol. 77, pp. 442-471, 2018.
- [12] M. Arshad, Z. Ullah, N. Ahmad, M. Khalid, H. Cruickshank, and Y. Cao, "A survey of local/cooperative-based malicious information detection techniques in VANETS," *EURASIP Journal on Wireless Communications and Networking*, vol. 2018, p. 62, 2018.
- [13] Arshad, Muhammad, Zahid Ullah, Muhammad Khalid, Naveed Ahmad, Waqar Khalid, Duri Shahwar, and Yue Cao. "Beacon trust management system and fake data detection in vehicular ad-hoc networks." *IET Intelligent Transport Systems* (2018).
- [14] M. R. Yuce and J. Khan, *Wireless body area networks: technology, implementation, and applications*: CRC Press, 2011.
- [15] B. Yuvaradni, D. Dhanahsri, G. Sonali, T. Gauri, and M. S. Thite, "Health monitoring services using wireless body area network," *Imperial journal of interdisciplinary research*, vol. 2, 2016
- [16] R. Negra, I. Jemili, and A. Belghith, "Wireless Body Area Networks: Applications and Technologies," *Procedia Computer Science*, vol. 83, pp. 1274-1281, 2016.
- [17] M. Ghamari, B. Janko, R. S. Sherratt, W. Harwin, R. Piechockic, and C. Soltanpur, "A survey on wireless body area networks for healthcare systems in residential environments," *Sensors*, vol. 16, p. 831, 2016.
- [18] S. Ullah, H. Higgins, B. Braem, B. Latre, C. Blondia, I. Moerman, et al., "A comprehensive survey of wireless body area networks," *Journal of medical systems*, vol. 36, pp. 1065-1094, 2012.
- [19] Zhou, Huan, Hui Wang, Xin Chen, Xiuhua Li, and Shouzhi Xu. "Data offloading techniques through vehicular ad hoc networks: A survey." *IEEE Access* 6 (2018): 65250-65259.
- [20] Huang, Chung-Ming, Yu-Fen Chen, Shouzhi Xu, and Huan Zhou. "The vehicular social network (VSN)-based sharing of downloaded geo data using the credit-based clustering scheme." *IEEE Access* 6 (2018): 58254-58271.
- [21] Zhang, Heng, Yifei Qi, Huan Zhou, Jian Zhang, and Jing Sun. "Testing and defending methods against DOS attack in state estimation." *Asian Journal of Control* 19, no. 4 (2017): 1295-1305.
- [22] I. Ha, "Even energy consumption and backside routing: An improved routing protocol for effective data transmission in wireless body area networks," *International Journal of Distributed Sensor Networks*, vol. 12, p. 1550147716657932, 2016.
- [23] S. Singh, S. Negi, A. Uniyal, and S. K. Verma, "Modified new-attempt routing protocol for wireless body area network," in *Advances in Computing, Communication, and Automation (ICACCA)*(Fall), International Conference on, 2016, pp. 1-5.
- [24] A. Ahmad, N. Javaid, U. Qasim, M. Ishfaq, Z. A. Khan, and T. A. Alghamdi, "RE-ATTEMPT: a new energy-efficient routing protocol for wireless body area sensor networks," *International Journal of Distributed Sensor Networks*, vol. 10, p. 464010, 2014.
- [25] R. A. Khan, K. H. Mohammadani, A. A. Soomro, J. Hussain, S. Khan, T. H. Arain, et al., "An energy efficient routing protocol for wireless body area sensor networks," *Wireless Personal Communications*, vol. 99, pp. 1443-1454, 2018.
- [26] V. Ayatollahitafii, M. A. Ngadi, J. bin Mohamad Sharif, and M. Abdullahi, "An Efficient Next Hop Selection Algorithm for Multi-Hop Body Area Networks," *PloS one*, vol. 11, p. e0146464, 2016.
- [27] M. el Azhari, A. Toumanari, R. Latif, and N. el Moussaid, "Relay based thermal aware and mobility support routing protocol for wireless body sensor networks," *International Journal of Communication Networks and Information Security (IJCNIS)*, vol. 8, 2016.
- [28] O. Smail, A. Kerrar, Y. Zetili, and B. Cousin, "ESR: Energy aware and Stable Routing protocol for WBAN networks," in *12th International Wireless Communications and Mobile Computing Conference (IWCMC 2016)*, 2016.
- [29] S. Adhikary, S. Choudhury, and S. Chattopadhyay, "A new routing protocol for WBAN to enhance energy consumption and network lifetime," in

Proceedings of the 17th International Conference on Distributed Computing and Networking, 2016, p. 40.

- [30] Z. Ullah, I. Ahmed, K. Razzaq, M. K. Naseer, and N. Ahmed, "DSCB: Dual sink approach using clustering in body area network," *Peer-to-Peer Networking and Applications*, pp. 1-14, 2017.
- [31] Y. Cao, X.-Y. Liu, L. Kong, M.-Y. Wu, and M. K. Khan, "EHR: Routing Protocol for Energy Harvesting Wireless Sensor Networks," in *Parallel and Distributed Systems (ICPADS)*, IEEE 22nd International Conference, pp. 56-63, 2016.
- [32] Y. Dong, J. Wang, B. Shim, and D. I. Kim, "DEARER: A distance-and-energy-aware routing with energy reservation for energy harvesting wireless sensor networks," *IEEE Journal on Selected Areas in Communications*, vol. 34, pp. 3798-3813, 2016.
- [33] J. Li and D. Liu, "An energy aware distributed clustering routing protocol for energy harvesting wireless sensor networks," in *Communications in China (ICCC)*, 2016 IEEE/CIC International Conference on, 2016, pp. 1-6.
- [34] W. B. Heinzelman, A. P. Chandrakasan, and H. Balakrishnan, "An application-specific protocol architecture for wireless microsensor networks," *IEEE Transactions on wireless communications*, vol. 1, pp. 660-670, 2002.
- [35] T. D. Hieu and B.-S. Kim, "Stability-Aware Geographic Routing in Energy Harvesting Wireless Sensor Networks," *Sensors*, vol. 16, p. 696, 2016.
- [36] E. Ibarra, A. Antonopoulos, E. Kartsakli, J. J. Rodrigues, and C. Verikoukis, "QoS-aware energy management in body sensor nodes powered by human energy harvesting," *IEEE Sensors Journal*, vol. 16, pp. 542-549, 2016.
- [37] Khan, Rahat Ali, and Al-Sakib Khan Pathan. "The state-of-the-art wireless body area sensor networks: A survey." *International Journal of Distributed Sensor Networks* 14, no. 4 (2018): 1550147718768994.
- [38] Z. A. Khan, S. Sivakumar, W. Phillips, and N. Aslam, "A new patient monitoring framework and Energy-aware Peering Routing Protocol (EPR) for Body Area Network communication," *Journal of Ambient Intelligence and Humanized Computing*, vol. 5, pp. 409-423, 2014.
- [39] W. R. Heinzelman, A. Chandrakasan, and H. Balakrishnan, "Energy-efficient communication protocol for wireless microsensor networks," in *System sciences*, 2000. Proceedings of the 33rd annual Hawaii international conference on, 2000, p. 10 pp. vol. 2.
- [40] I. Yoon, D. K. Noh, and H. Shin, "Energy-aware hierarchical topology control for wireless sensor networks with energy-harvesting nodes," *International Journal of Distributed Sensor Networks*, vol. 11, p. 617383, 2015.
- [41] N. Katayama, K. Takizawa, T. Aoyagi, J.-i. Takada, H.-B. Li, and R. Kohno, "Channel model on various frequency bands for wearable body area network," *IEICE transactions on communications*, vol. 92, pp. 418-424, 2009.
- [42] S. Ullah, P. Khan, N. Ullah, S. Saleem, H. Higgins, and K. S. Kwak, "A review of wireless body area networks for medical applications," *arXiv preprint arXiv:1001.0831*, 2010.



ZAHID ULLAH is Higher Education Commission (HEC) scholar and currently pursuing PhD in Computer Sciences at Institute of Management Sciences, Peshawar, Pakistan. He is working as Assistant Professor in Centre of Excellence in IT, at Institute of Management Sciences Peshawar, Pakistan. He received his BCS(Hons) degree in Computer Science from KPK, Agricultural university Peshawar, Pakistan in 2005 and Master (M-S) Degree in Telecommunication and Networking

from Gandhara University Peshawar, Pakistan in 2008. He has more than 14 years of practical and teaching experience in computer sciences and got hands on experience in different networking related devices. He has got several Cisco, Juniper and Microsoft international certifications in computer sciences field, especially in networks. His research interest includes Wireless Sensor Network, Underwater Sensor Networks, Wireless body area network, Internet of things, VANETS and Delay Tolerant Networks.



IMRAN AHMED is currently working as Assistant Professor at Institute of Management Sciences, Peshawar, Pakistan. He received his PhD degree in Electronics and Electrical Engineering from University of Southampton, UK. He did his MS-IT from Institute of Management Sciences, Peshawar, in Digital image and signal processing. He received B.Sc. degree in Computer Science and Mathematics from Edwardes College, Peshawar, Pakistan and M.Sc. degree in Computer Science

from University of Peshawar, Pakistan. Before joining IMSciences, he worked as Assistant Professor at Islamia College University, Peshawar, Pakistan. He is currently working in the area of Computer Vision, Features extraction, digital image and signal processing, Medical Image Processing, Biometric, Pattern Recognition, Wireless sensor networks/ Wireless Body Area Network and Data mining.



TAMLEEK ALI is currently working as Assistant Professor at Institute of Management Sciences, Peshawar, Pakistan. He received his PhD degree in Computer Sciences with specialization in network security from Institute of Management Sciences, Peshawar, Pakistan. He did his MS-CS from International Islamic university, Islamabad, Pakistan in 2008. He received his M.Sc. degree in Computer Science from University of Peshawar, Pakistan in 2002. Before joining IMSciences, he worked

as system engineer in IQRaNet Internet Service Provider. His speciality is remote attestation and trust in large distributed environments. He has several research publications in conference and international journals. He is currently working towards incorporating machine learning in large scale malware analysis.



NAVEED AHMAD is currently working as Assistant Professor in Department of Computer Science, University of Peshawar since April 2013. Prior to joining the department, he received PhD degree from the Institute for Communication Systems (ICS) formerly known as Centre for Communication Systems Research, at University of Surrey, Guildford, UK in March 2013. His research interest lies in Delay Tolerant Networks, Intelligent Transport System, Security and Privacy.



FAHIM NIAZ is a Visiting Lecturer in the Department of Computer Science at KPK Agricultural University Peshawar, Pakistan. He is also working as Secondary School Teacher of Information Technology (SST-IT) at Khyber Pakhtunkhwa Education Department Peshawar, Pakistan. He received his MCS degree from Institute of Management Sciences Peshawar and MS Computer Science from Bahria University, Islamabad. His research interests include IoT, Wireless Sensor Networks,

Underwater Sensor Network, Wireless Big Data and Delay Tolerant Networks.



YUE CAO received the PhD degree from the Institute for Communication Systems (ICS), University of Surrey, UK in 2013. He was the Research Fellow at ICS, University of Surrey, UK; Lecturer and Senior Lecturer at Department of Computer and Information Sciences, Northumbria University, UK; and has been the International Lecturer at School of Computing and Communications, Lancaster University, UK. His research interests focus on Intelligent Transport Systems.

He is the Associate Editor of IEEE Access, KSII Transactions on Internet and Information Systems, IGI Global International Journal of Vehicular Telematics and Infotainment Systems.

• • •