



FINAL PUBLISHABLE JRP REPORT

JRP-Contract number ENV55
 JRP short name MetNH3
 JRP full title Metrology for Ammonia in Ambient Air
 Version numbers of latest contracted Annex Ia and Annex Ib against which the assessment will be made
 Annex Ia: V1.0
 Annex Ib: V1.0
 Period covered (dates) From 01 June 2014 To 31 May 2017
 JRP-Coordinator Bernhard Niederhauser, METAS

Tel: +41 (0)58 387 02 62

Email: bernhard.niederhauser@metas.ch

JRP website address <http://metnh3.eu>

Other JRP-Partners
 JRP-Partner 2 BAM, Germany
 JRP-Partner 3 DFM, Denmark
 JRP-Partner 4 VTT, Finland
 JRP-Partner 5 NPL, United Kingdom
 JRP-Partner 6 PTB, Germany
 JRP-Partner 7 UBA, Germany
 JRP-Partner 8 VSL, Netherlands

REG-Researcher
 (associated Home Organisation)

Researcher name, title Christine Braban, Dr. Start date: 01/09/2014
 (Home organisation Short name, country) NERC, United Kingdom Duration: 30 months

Researcher name, title Olavi Vaittinen, Dr. Start date: 01/03/2015
 (Home organisation Short name, country) UH, Finland Duration: 18 months

Report Status: PU Public





TABLE OF CONTENTS

1 Executive Summary 3

2 Project context, rationale and objectives..... 4

 2.1 Project context 4

 2.2 Rationale..... 4

 2.3 Objectives 5

3 Research results 5

 3.1 Development of improved reference gas mixtures by static and dynamic gravimetric generation methods 5

 3.2 Development and characterisation of optical transfer standards 14

 3.3 Establishing the transfer from high-accuracy standards to field applicable methods 25

4 Actual and potential impact 32

 4.1 Dissemination activities..... 32

 4.2 Early impact 32

 4.3 Potential impact 34

5 Website address and contact details 35

6 List of publications..... 35

Abbreviations

CRDS	cavity ring-down spectroscopy
CRM	certified reference material
QCLAS	quantum cascade laser absorption spectroscopy
TDLAS	tuneable diode laser absorption spectroscopy
MIR	mid-infrared
MCT	mercury-cadmium-telluride (detector type)
NMI	national metrology institute
OTS	optical transfer standard

1 Executive Summary

Introduction

The capabilities developed in this project are the basis for improving quality assurance and quality control (QC/QA) measures, as well as attaining metrological traceability to the SI units. Improved calibration techniques are applicable by European air quality monitoring networks allowing for accurate and robust data of ammonia (NH₃) in ambient air. This is a prerequisite for short- and long-term assessment of the success of emission reduction measures.

The Problem

Measuring NH₃ in ambient air is a sensitive and priority issue due to its harmful effects on human health and ecosystems. However, there is a lack of regulation to ensure reliable ammonia measurements, namely in calibration capabilities for applicable analytical technology, an agreement on maximum allowed uncertainty, effective quality assurance and quality control (QC/QA) procedures, as well as in the infrastructure to attain metrological traceability.

In a recent intercomparison among European NMIs, substantial discrepancies for the analysis of certified reference materials (CRM) were found, despite the fact that the comparison was performed for amount-of-substance fractions far above typical ambient air levels. Moreover, the performance of the multitude of applied measurement techniques varies in both resolution and precision and they often lack in sufficient means for calibration. In addition, adsorption of NH₃ on instrument surfaces and chemical reactions on instrument inlets compromise the accuracy of the sample introduction. This threatens not only the credibility of instrumental performance but also the scientific value of extensive ambient air monitoring by national networks as well as the comparability of data across countries.

The Solution

The overarching objective of MetNH3 was to achieve metrological traceability for ammonia measurements in ambient air from primary certified reference material (CRM) and instrumental standards and the transfer to the field. To achieve these goals the project focussed on:

Developing improved reference gas mixtures by static and dynamic gravimetric generation methods of NH₃ amount fractions similar to those in ambient air based on existing methods for other reactive analytes.

Developing laser-based optical transfer standards.

Establishing the transfer from high-accuracy standards to field applicable methods by employment of characterised exposure chambers as well as field sites for validation and comparison experiments.

Impact

Output from the project has already been implemented by several groups of the targeted end-users:

Manufacturers of CRM are applying the findings to improve the long-term stability of CRM prepared by static gravimetry by avoiding adsorption losses (dominant uncertainty contribution) and by adapting their production process.

Improved and validated software for general least squares fitting including uncertainty propagation of input parameters has been used to implement a new spectral data evaluation method for a commercial spectrometer, enabling the required uncertainty propagation in compliance with the GUM and the determination of relevant metrological quantities such as uncertainty contributions and covariance.

The establishment of traceable, absolute laser-spectrometer as optical transfer standards for ammonia in air has the prospect of supplementing (and to a certain degree perhaps replacing) calibrations using reference gas mixtures.

The impact of newly produced CRM has enabled a laboratory assessment of currently employed diffusive uptake rates of passive sampler and denuders to be carried out for the first time.

In the framework of intercomparisons, not only passive samplers but also different extractive optical methods were tested, amongst others the OTS developed in this project. For the first time, on-site calibrations were carried out, employing the different calibration methods developed in this project.

2 Project context, rationale and objectives

2.1 Project context

Measuring ammonia in ambient air is a sensitive and priority issue due to its harmful effects on human health and ecosystems. Ammonia is the major precursor for neutralising atmospheric acids and thus affects the long-range transport of SO₂ and NO_x as well as the stabilisation of secondary particulate matter (PM₁₀, PM_{2.5} and aerosols). Depending on their location in the atmosphere, PM have either a negative or a positive radiative forcing potential by scattering or absorbing radiation, respectively. By additionally acting as cloud condensation nuclei, this potential is further enhanced. The eventual deposition of ammonia bound in various molecules contributes to eutrophication and acidification of land and fresh water and thus to a reduction in soil and water quality. This has negative effects on biodiversity and ecosystems. Moreover, high PM levels in the lower troposphere negatively affect human health by being closely related to a clustered occurrence of respiratory and cardiovascular diseases.

Ammonia emissions are estimated to have at least doubled over the last century across Europe. The primary causes for ammonia emissions are intensive agriculture (particularly fertilisation with urea), together with various non-agricultural sources such as sewage treatment, catalytic converters, anaerobic digesters (rapidly increasing since 2010) and industrial processes. Emissions from diesel vehicles will increase in the future, particularly in urban environments, due to the application of urea as a selective catalyst for reducing NO_x emissions.

Air pollution spreads across national borders and over long distances. In 1999 ammonia was included under the UNECE Gothenburg Protocol (revised in 2012), which is part of the convention on Long-Range Transboundary Air Pollution. The protocol was designed to reduce acidification, eutrophication and ground-level ozone by setting emissions ceilings to be met by 2010. The European Directive 2016/2284/EU on the reduction of national emissions of certain atmospheric pollutants sets individual emission ceilings for each member state to be met by 2020 for five pollutants (ammonia, sulphur dioxide, nitrogen oxides, volatile organic compounds and fine particulate matter) responsible for acidification, eutrophication and ground-level ozone pollution which leads to significant negative impacts on human health and the environment. The European Directive 2016/2284/EU, based on the revised Gothenburg Protocol, sets even more ambitious reduction commitments for 2030 so as to cut the health impacts of air pollution by half compared with 2005. This has led to the incorporation of ammonia measurements into national air monitoring networks.

However, there is a lack of regulation to ensure reliable ammonia measurements, namely in applicable analytical technology, maximum allowed uncertainty, quality assurance and quality control (QC/QA) procedures, as well as in the infrastructure to attain metrological traceability.

2.2 Rationale

Currently, ammonia concentrations in ambient air are determined mainly by the application of diffusive samplers and denuders. This method is quantitative and fairly reliable but ammonia is measured indirectly and in insufficient temporal resolution.

There are a multitude of instruments available applying spectroscopic techniques and allowing for direct measurements. However, they lack traceability and neither inlet systems nor relative humidity controls are sufficient to reliably control issues associated with ambient measurements of ammonia. Moreover, acquisition costs are considerable and they still require calibration with CRMs if no absolute measurement operation method is implemented.

CRMs for ammonia are commercially available in amount of substance fractions >30 μmol mol⁻¹. However, ammonia in ambient air occurs at amount of substance fractions between 0.5 and 500 nmol mol⁻¹, i.e. 60 to 60,000 times lower concentrations of CRM are required for the calibration of instruments applied for ambient air monitoring. The main reason for this discrepancy is a consequence of ammonia's high adsorptivity on various surfaces and reactivity with water, leading to unstable ammonia amount fraction measurement results and long stabilisation times. Such adsorption and desorption effects occur at all surfaces and therefore affect the traceability of ammonia measurements not only indirectly via reference gas mixtures in bottles but also directly by occurring in inlet and sampling systems of on-line instruments and diffusive samplers

The discrepancies among European NMIs found in recent intercomparisons are substantial for the analysis of certified reference materials (CRM) in spite of them having been analysed at 30 to 50 μmol mol⁻¹ and thus at

amount of substance fractions far above those of ambient air. Moreover, the performance of the multitude of applied measurement techniques varies in both resolution and precision. This threatens not only the credibility of instrumental performance due to insufficient means provided for calibration, but also the scientific value of extensive ambient air monitoring by national networks as well as the comparability of data across countries. These issues have to be overcome by the development of new analysis methods and novel approaches for the production of CRMs.

2.3 Objectives

The overarching objective of the project was to achieve metrological traceability for NH₃ measurements at ambient air concentrations using primary CRMs, and to develop instrumental standards for their application in the laboratory and in the field. This required the successful completion of the project's three objectives:

1. *To develop improved reference gas mixtures by static and dynamic gravimetric generation methods*

Realisation and characterisation of traceable preparative calibration standards (CRM as well as mobile generators) of NH₃ amount fractions similar to those in ambient air. This includes solving the problem of existing discrepancies between gas standards. The production/purification of a high purity matrix gas with validated levels of NH₃ is a prerequisite for the preparation of static and dynamic reference standard mixtures.

2. *To develop and characterise laser based optical spectrometric standards*

Evaluation of the applicability of a newly developed open-path (where the optical path is open to the environment) as well as of existing extractive measurement techniques and characterisation of both as optical transfer standards according to metrological principles.

3. *To establish the transfer from high-accuracy standards to field applicable methods*

Evaluation of existing measuring instruments for traceable measurement of NH₃ at ambient molar fractions (0.5 to 500 nmol mol⁻¹) under real air and laboratory conditions, and to evaluate and compare results to develop suitable sampling methods in order to promote long-term efficiency in monitoring of NH₃ reduction measures with at the required level of uncertainty. Finally, to provide validated measurement tools to enable EU SMEs developing new monitoring technologies to deliver improved instrumentation to the market.

3 Research results

3.1 *Development of improved reference gas mixtures by static and dynamic gravimetric generation methods*

3.1.1 **Adsorption of NH₃ on material surfaces and at different levels of humidity**

Several sources have reported adsorption effects occurring at surfaces of instrument inlets and on material surfaces. The large dipole of the NH₃ molecule and its hydrophilic properties are the reasons for its interaction with polar surface groups and its attraction to surface points where adsorbed or liquid water accumulates. Two main adsorption processes are therefore occurring on surfaces in contact with NH₃: physisorption and chemisorption.

If physisorption is the prevailing process, equilibrium between adsorption and desorption of the molecules will eventually be reached and effective NH₃ amount fractions will be detectable provided that no changes in temperature and pressure occur. In a dynamic system, this is a matter of stabilisation and thus of response time. In a static system such as pressurised gas cylinders with variability in temperature and pressure – the latter associated with cylinder filling level, – the equilibrium between adsorbed and desorbed molecules is dynamic and thus the number of molecules exiting the cylinder is continuously changing.

The process of chemisorption has to be absolutely avoided in the preparation of reference gas mixtures, since it is associated with chemical reactions occurring between different molecules (e.g. NH₃ and H₂O forming NH₄⁺ and OH⁻) on material surfaces and would lead to a permanent removal of NH₃ molecules and thus to a change in detectable amount fractions.

In the framework of MetNH3, tests were performed by METAS, REG(UH) and VSL assessing the magnitude of adsorption losses and recovery times in association with different material surfaces commonly applied in gas analysis. The experiment design closely followed the approach of Vaittinen et al. (2014). Adsorption of a 300 nmol mol⁻¹ NH₃ gas mixture in purified N₂ containing H₂O ≤ 1 μmol mol⁻¹ on pieces of previously cleaned tubing of different properties was assessed. The results of Table 1 are also published in Pogány et al. (2016).

Table 1: Adsorption of ammonia on surface materials

Surface material	Adsorption of NH ₃ / 10 ¹² molecules × cm ⁻²	Standard deviation (3 measurements) / 10 ¹² molecules × cm ⁻²
Stainless steel 316L	138	21
Electro-polished stainless steel 316L	72	11
Dursan ^{®1}	101	5
SilcoNert1000 ^{®1}	15	1
SilcoNert2000 ^{®1}	6	1
Teflon-perfluoroalkoxy (Teflon-PFA)	4	n/a

¹ SilcoTek Corporation <https://www.silcotek.com/> (accessed 16/03/2017)

It can be seen in Fig. 1 that stainless steel is the most and Teflon-PFA the least adsorbing material. The silica-based coating SilcoNert2000[®] applied to stainless steel surfaces by chemical vapour deposition proved to have similar properties as Teflon-PFA. SilcoNert2000[®] is currently state of the art in surface coating for reactive gas species. Thus many of the project partners have all stainless steel surfaces in contact with NH₃ coated with SilcoNert2000[®] in order to reduce adsorption by 95 % compared to uncoated stainless steel.

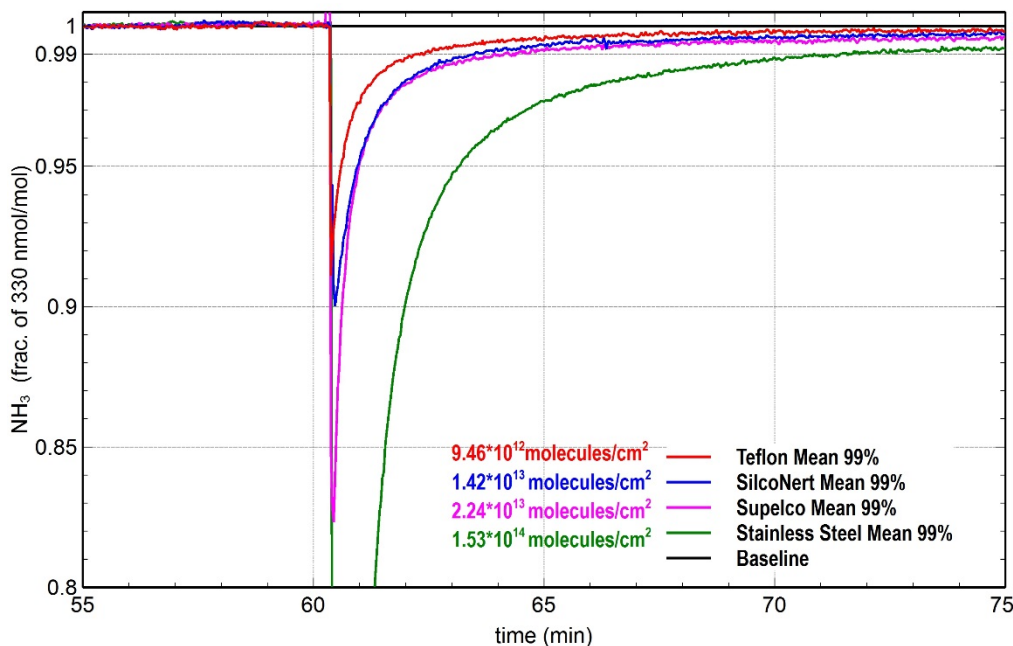

Figure 1: Results for the study on adsorption of NH₃ on different surface materials. An equal surface area of four different materials was flushed clean and dry and then exposed to a continuously produced NH₃ in N₂ gas mixture of (330 ± 4) nmol mol⁻¹. The amount of adsorbed molecules was calculated over time until concentrations recovered to 99 % of the initial values. The experiment was repeated three times on every material.

Competition between molecules of H₂O and NH₃ for adsorption on surface area is strong. Fast reaction kinetics between H₂O and NH₃ could lead to chemisorption depending on concentrations. The dissolution of NH₃ in multilayers of OH⁻ and H₂O is the cause of severe problems for the preparation of reference gas mixtures thus it was a task within MetNH3 to test the effect of different levels of humidity on the adsorption of NH₃ on surfaces. For this purpose, the previous adsorption experiments on different material surfaces were continued with NH₃ amount fractions at $(300 \pm 15) \text{ nmol mol}^{-1}$ but the dilution gas contained H₂O at amount fractions 10 - 25,000 $\mu\text{mol mol}^{-1}$.

It can be seen in figure 2 that with increasing rates of humidity, the number of adsorbed NH₃ molecules decreases until they reach a minimum at around 10,000 $\mu\text{mol mol}^{-1}$ (1 % or 40 % RH). When the humidity was increased to 11,000 $\mu\text{mol mol}^{-1}$ (1.1 % or 44 % RH), adsorption of NH₃ increased. This observed change of adsorption at 1.1 % humidity might indicate the removal of NH₃ molecules from the gas stream by another process than adsorption to the material surface. This process could be the chemical absorption of NH₃ into the H₂O layers forming at the material surfaces.

As spectroscopic measurements of NH₃ are corroborated by the presence of H₂O adsorption lines at similar wavelengths as those of NH₃, a request for reference gas mixtures at ambient air H₂O amount fractions has been raised. Based on the outcome of the adsorption experiments this request cannot be met for amount fractions H₂O $\geq 10,000 \mu\text{mol mol}^{-1}$. For lower amount fractions, experiments thoroughly assessing the potential effect of chemisorption at different amount fractions of H₂O $\leq 10,000 \mu\text{mol mol}^{-1}$ and associated uncertainty contributions would have to continue. Such mixtures would have to be generated dynamically on real-time with the measurements as adsorption/desorption processes can be monitored directly and equilibria will eventually be reached.

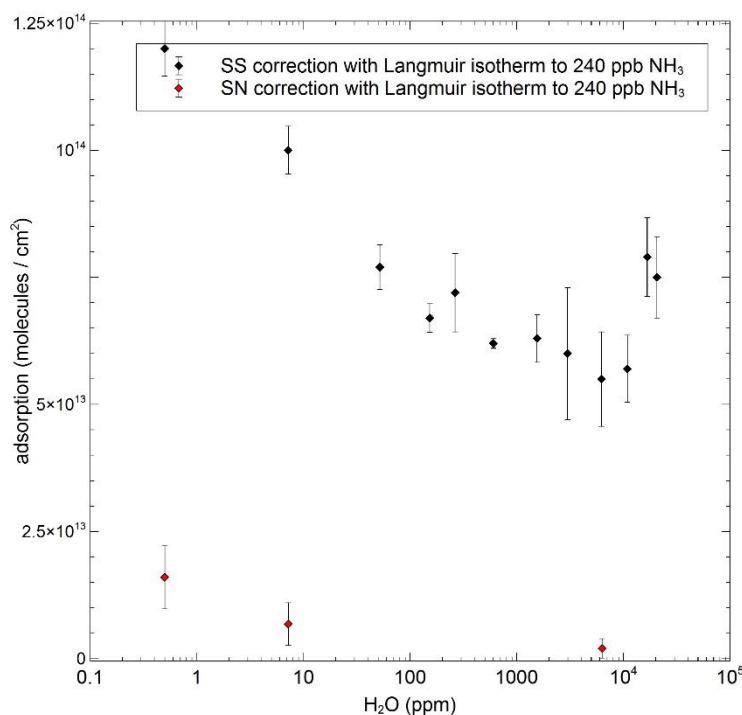

Figure 2: Results for the study on adsorption of NH₃ on different surface materials (electro polished stainless steel and SilcoNert2000®) at different levels of humidity. An equal surface area of four different materials was flushed clean and then exposed to a continuously produced NH₃ in N₂ gas mixture of $(240 \pm 3) \text{ nmol mol}^{-1}$ at different levels of humidity from dry $7 \mu\text{mol mol}^{-1}$ to ambient 10 mmol mol^{-1} of water H₂O. The amount of adsorbed molecules was calculated over time until concentrations recovered to 99 % of the initial values. The experiment on every material was repeated three times.

3.1.2 Development of improved static reference gas mixture standards

NPL and VSL have tested different cylinder types by performing a series of decant tests at the 100 and 10 $\mu\text{mol mol}^{-1}$ levels and performed stability tests on those mixtures over a period of up to 24 months.

VSL performed decanting and stability tests on three commercial types of gas cylinders: Spectra Seal (BOC), Aculife 4 (Air Liquide) and cylinders provided by Takachiho. At NPL, Spectra Seal cylinders (BOC) were tested for redundancy, and in addition, stainless steel cylinders which had been coated with SilcoNert2000[®]. All cylinders showed individual behaviour in adsorption on the interior surfaces. The stability tests performed at VSL (figure 3) show that:

- The ammonia mixtures of 100 $\mu\text{mol mol}^{-1}$ are stable for 24 months in both Aculife 4 and Spectra Seal cylinders within a 1 % relative uncertainty ($k = 2$)
- The ammonia mixtures of 10 $\mu\text{mol mol}^{-1}$ are stable for a period of 12 months within a 3 % uncertainty; cylinders under test were Aculife 4 (AC4), Spectra Seal (SS) and cylinders provided by Takachiho (T)

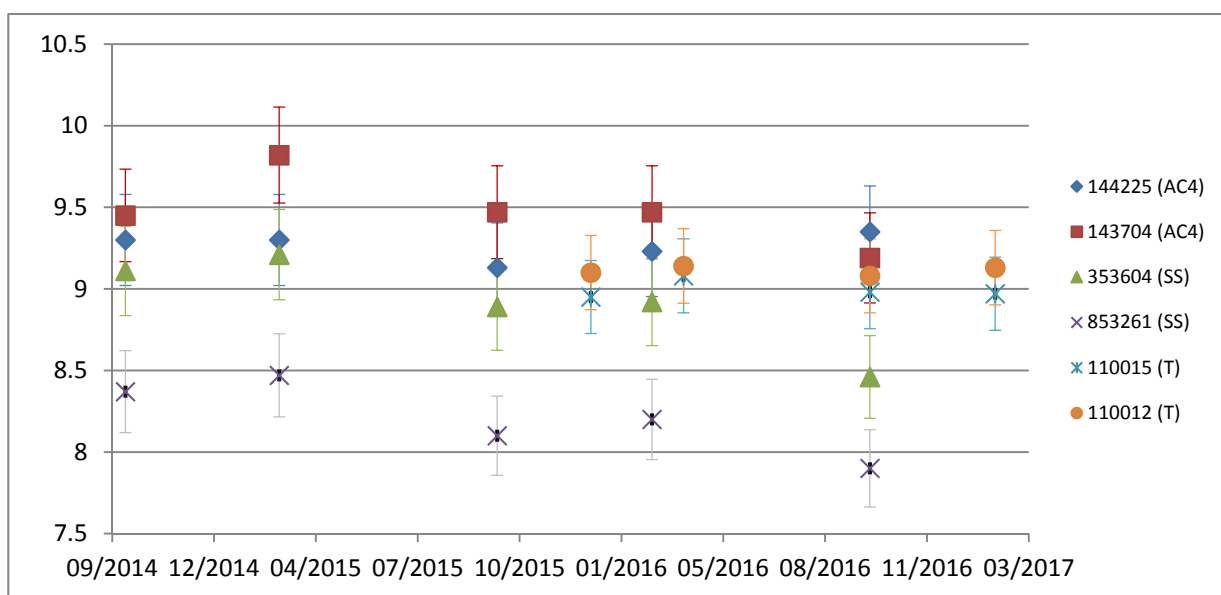

Figure 3: Results for the stability of 6 VSL mixtures at 10 $\mu\text{mol mol}^{-1}$ of NH_3 in nitrogen. The uncertainty bars represent an expanded uncertainty (with $k = 2$ for a coverage probability of approximately 95 %).

The stability measurements carried out at NPL (figure 4) show that:

- The ammonia standard mixtures are completely stable in the BOC cylinders at 100 $\mu\text{mol mol}^{-1}$ level and, after an initial small decay, are stable at 10 $\mu\text{mol mol}^{-1}$, over the time period studied;
- The SilcoNert2000[®] treatment applied to stainless steel cylinders is the most suitable for ammonia mixtures at the lowest level of the NH_3 amount fraction investigated i.e. 10 $\mu\text{mol mol}^{-1}$. No adsorption loss can be observed.

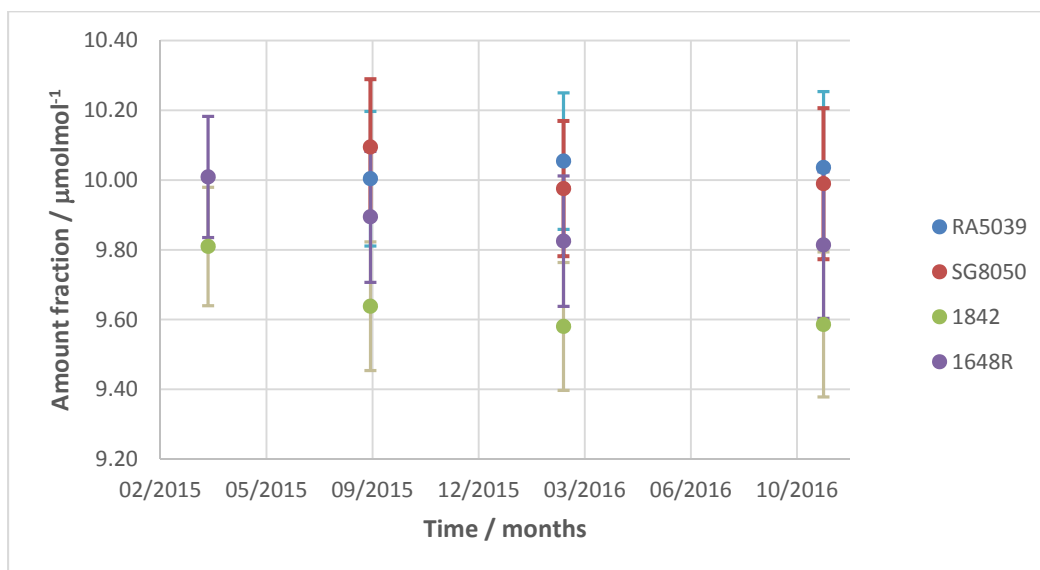

Figure 4: Results for the stability of 4 NPL mixtures at $10 \mu\text{mol mol}^{-1}$ of NH_3 in nitrogen of which RA5039 and SG8050 are SilcoNert2000 coated cylinders and 1842 and 1648R are BOC cylinders treated with Spectraseal. The uncertainty bars represent an expanded uncertainty (with $k = 2$ for a coverage probability of approximately 95%).

From these stability studies it can be concluded that:

- Adsorption losses over shorter and longer periods on CRM at the $100 \mu\text{mol mol}^{-1}$ level are negligible
- Adsorption losses over shorter and longer periods on CRM at the $10 \mu\text{mol mol}^{-1}$ level are significant and are the main contributor to the uncertainty budget unless they have been stored in commercially available stainless steel cylinder with SilcoNert2000® coating.

Over the course of MetNH3 VSL adapted its preparation procedure to reduce adsorption by minimising the surface exposed to NH_3 during decanting and by applying only coated materials. Moreover, the analysis and verification procedure for NH_3 mixtures were optimised, thus reducing the analytical uncertainty from 3 % relative to 1 % relative on the $30 \mu\text{mol mol}^{-1}$ amount fraction.

3.1.3 Development of improved dynamic reference gas mixture standards

At METAS a mobile instrument for the dynamic generation of SI-traceable NH_3 reference gas mixtures has been planned and realised. ReGaS1 (Reactive Gas Standard 1) is a development beyond the state of the art as it allows for the on-site permeation and dynamic dilution over two dilution steps and thus for the dynamic generation of NH_3 at ambient amount fractions ($0.5 - 500 \text{ nmol mol}^{-1}$) with $U_{\text{NH}_3} \leq 3 \%$ ($k = 2$).

The traceable dynamic generation of reference gas mixtures (RGM) according ISO standard 6145 combines the continuous, temperature and pressure dependent permeation of a pure substance into purified matrix gas with the dynamic dilution of the CRM to desired amount of fraction levels using thermal mass flow controllers (MFC) (parts 7 and 10 of ISO 6145). The method has the advantage of being fully traceable to SI standards, applicable over long time and flexible in the range of the generated amount fractions corresponding to ambient air levels. The application of two dilution steps reduced the required amount of dilution gas.

The uncertainty of the generated gas mixtures can be considerably reduced when the mass loss of the permeation source is monitored in a magnetic suspension balance. The greatest advantage of dynamic generation and dilution in the case of reactive gases such as ammonia (NH_3) is the possibility to avoid adsorption/desorption effects on surface walls by allowing the mixture to stabilise at equilibrium conditions. As shown before, stabilisation times can be greatly reduced by applying silica-based coating (e.g. SilcoNert2000 by SilcoTek) on gas wetted surfaces.

The disadvantages of dynamic generation/dilution are the labour intensive calibration of all individual components, and the fact that the resulting reference gas mixture cannot be certified. The ammonia RGM can

be used directly for the calibration of standard optical methods but the primary system is stationary in the laboratory and the demand for use of the magnetic suspension balance (MSB) at METAS is high. Moreover, end-users such as measurement networks require mobile calibration possibilities. Thus, it was decided to construct a transfer standard in the shape of ReGaS1, a dynamic reference gas generator for the mobile generation of RGM.

Description and specifications

For the dynamic generation and subsequent dilution of primary RGM in the laboratory, METAS combines the temperature and pressure dependent permeation through a selective polymer membrane of a pure substance stored in a permeation tube (Fine Metrology) into purified matrix gas (zero air, N₂ or synthetic air). Temperature and pressure are controlled in a permeation chamber, which is combined with an electromagnetic balance continuously measuring the resulting mass loss Δm over time Δt of the permeation tube (Stainless Steel magnetic suspension balance by Rubotherm) resulting in a permeation rate ($PR / \text{ng min}^{-1}$) for given initial conditions. The base mixture, i.e. the ammonia permeant in the carrier gas flow is dynamically diluted in one or two steps to cover the dynamic mixing ratio of 1 to 1000 and thus to desired amount of fraction levels using MFCs (Vögtlin red-y smart series).

All input quantities are fully traceable to national realisations of SI standards.

The applicability of the device under field conditions was a particular aim and so, Reactive Gas Standard 1 (ReGaS1) was constructed according to the flow path design in figure 5.

The single but most important difference between the stationary system using the MSB and the mobile ReGaS1 is the permeation oven (Dynacalibrator, VICI Int.) which is used in ReGaS1 to control the temperature of the permeation source instead of the permeation chamber. Since the permeation rate cannot be measured continuously in the permeation oven, it has to be determined in the MSB prior and after the transfer of the permeation tube into ReGaS1 (long-term stability). Temperature and pressure are kept constant in both devices to minimise the variability and thus the uncertainty of the generated base mixture. As depicted in figure 5, the flow of MFC_c (carrier gas flow) is used to dilute the permeant NH₃ to the base mixture.

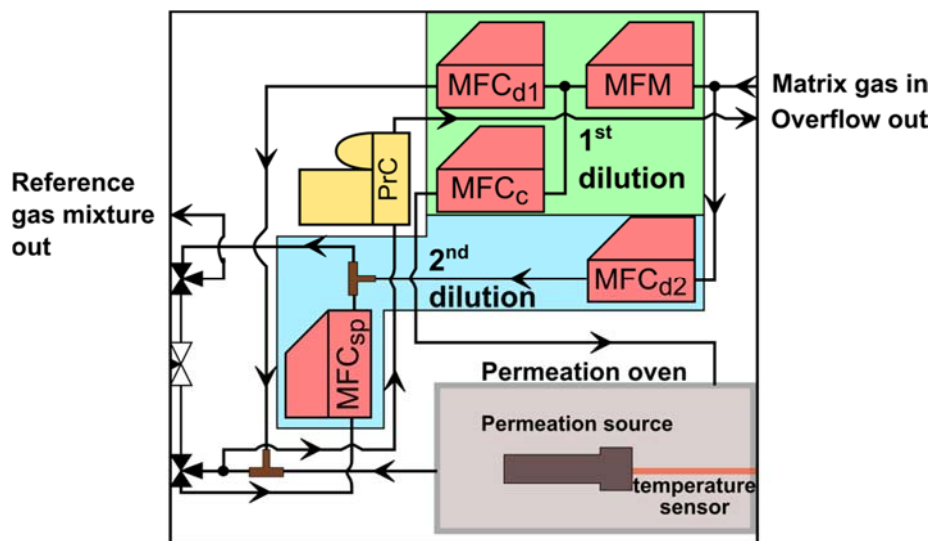

Figure 5: Schematic flow path of ReGaS1, see text below for explanations.

In order to reduce the amount fraction of the base mixture by a factor 20, MFC_{d1} is used. MFC_c and MFC_{d1} make the first dilution RGM, which can be used directly for calibration purposes in the molar fraction range 50 - 500 nmol mol⁻¹, provided $PR = 200 \text{ ng min}^{-1}$ and base gas flow = 0.3 L min⁻¹.

Should the desired amount fraction be of the order 0.5 – 50 nmol mol⁻¹ the NH₃ concentration of the first dilution can be diluted by up to another factor 250. For this purpose, a part of the first dilution becomes the base mixture and is split off (MFC_{sp}) and diluted in a second dilution step (MFC_{d2}). Two manual three-way valves are used to switch between the two dilution steps as well as one needle valve to regulate the pressure and flow.

As mentioned above, adsorption on gas-wetted surfaces can be greatly reduced by applying SilcoNert2000 on electro-polished stainless steel. Thus, the permeation oven, all tubing (1/8 and 1/4 outer diameter) as well as all connections (Swagelok), valves and MFC_{sp} in contact with the RGM were coated. The coating and thus the reduced adsorption make stabilisation times very short as can be seen in Figures 6 and 7 which depict the generated output flow connected to a CRDS (Picarro Inc.).

The housing is a 19 inch rack (Schroff, 10225-637) and the device is piloted via a CRIO-9030 Controller (National Instruments) and operated over an LCD Monitor Touch Panel 8.4".

Table 2: Components contained in ReGaS1

Acronym	Component	Art. No.	manufacturer
Permeation oven	Dynacalibrator 150 permeation oven	MT-Dynacal-150-C-SI2K	VICI International
PrC	EL-Press digital pressure controller	P-702CV-6KA0A-BAD-88-E	Bronkhorst
MFM	V-red-y Smart thermal mass flow controller 5-500 ml/min	GSC-A5TT-BB22	Vögtlin
MFC _{sp}	V-red-y Smart thermal mass flow controller 2-200 ml/min	GSC-A4TT-BB21	Vögtlin
MFC _{d1} MFC _{d2}	V-red-y Smart thermal mass flow controller 50-5000 ml/min	GSC-B5TT-BB23	Vögtlin
MFM	V-red-y Smart thermal mass flow meter 60-6000 ml/min	GSM-B9TT-BN00	Vögtlin
	Thermometer, Tweener, Thermistor, 220V	HART 1504-256	FLUKE
	Thermistor-Sensor 5kOhm	YSI46007	ELCAL AG

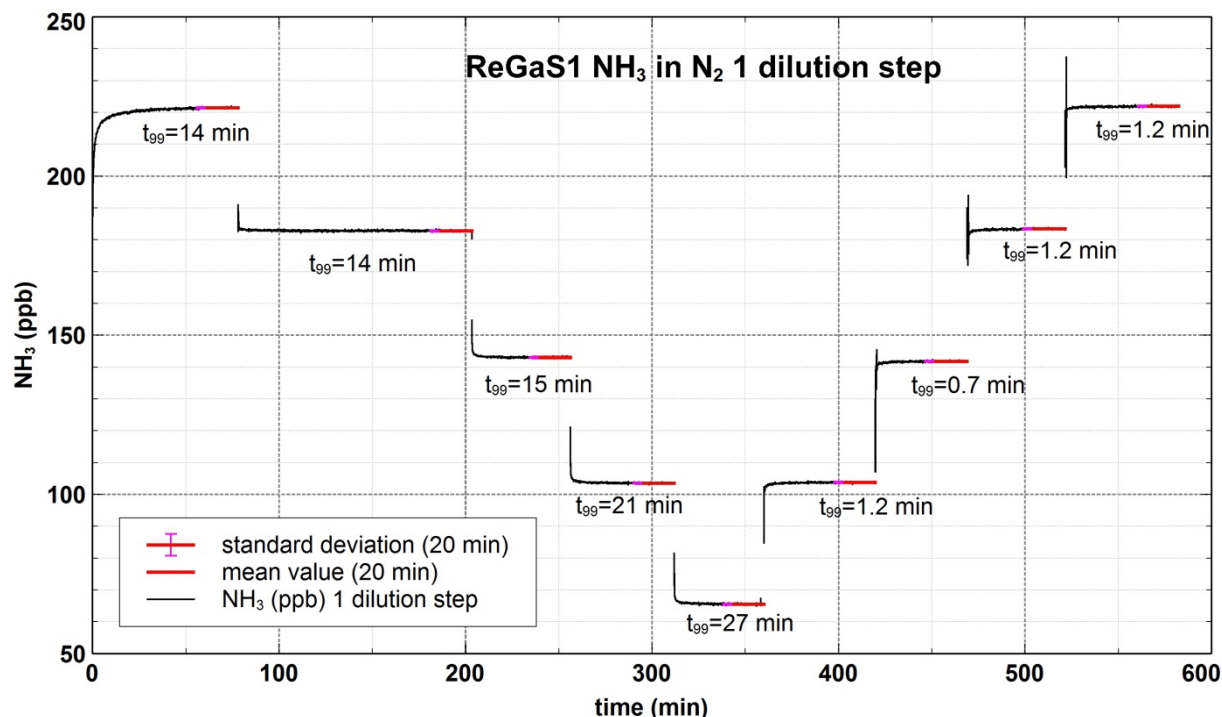

Figure 6: NH₃ amount fractions generated with one dilution step. Note that the individual parts of the instrument at that time have not yet been calibrated. The time t_{99} which passed until amount fractions had reached 99 % of the final stable amount fractions was determined. The standard deviation over the last 20 min of every step was calculated. The standard deviation is smaller than the measurement noise of the CRDS (1 ppb).

Stability of temperature and pressure yield a constant mass loss of the permeation unit ($U_{qmc} \leq 1 \%$, ($k = 2$)). Mass flow rates are modifiable within seconds and thus allow for readily changing the generated amount of substance fractions over two dilution steps covering the entire range of atmospheric amount fractions ($0.5 - 500 \text{ nmol mol}^{-1}$) with $U_{\text{NH}_3} \leq 3 \%$ ($k = 2$). The stabilisation time required to measure stable values is primarily depending on the adsorption on the surfaces of the comparator to be calibrated as can be seen in Figs. 7 and 8.

ReGaS1 was employed in the following MetNH₃ intercomparisons for generating reference gas mixtures with amount fractions $\leq 120 \text{ nmol mol}^{-1}$

- Jun 2016 Laboratory intercomparison UBA Langen, Germany
- Aug/Sep 2016 Field intercomparison CEH Edinburgh, Scotland
- Nov 2016 Laboratory intercomparison PTB Brunswick, Germany

The prerequisites for ReGaS1 in terms of amount of substance fractions as well as uncertainty ($0.5 - 500 \text{ nmol mol}^{-1}$ at $U_{\text{NH}_3} \leq 3 \%$, ($k = 2$)) could be met. The user feedbacks were positive throughout with particular emphasis on the user friendliness and the vast flexibility in the generated amount fractions.

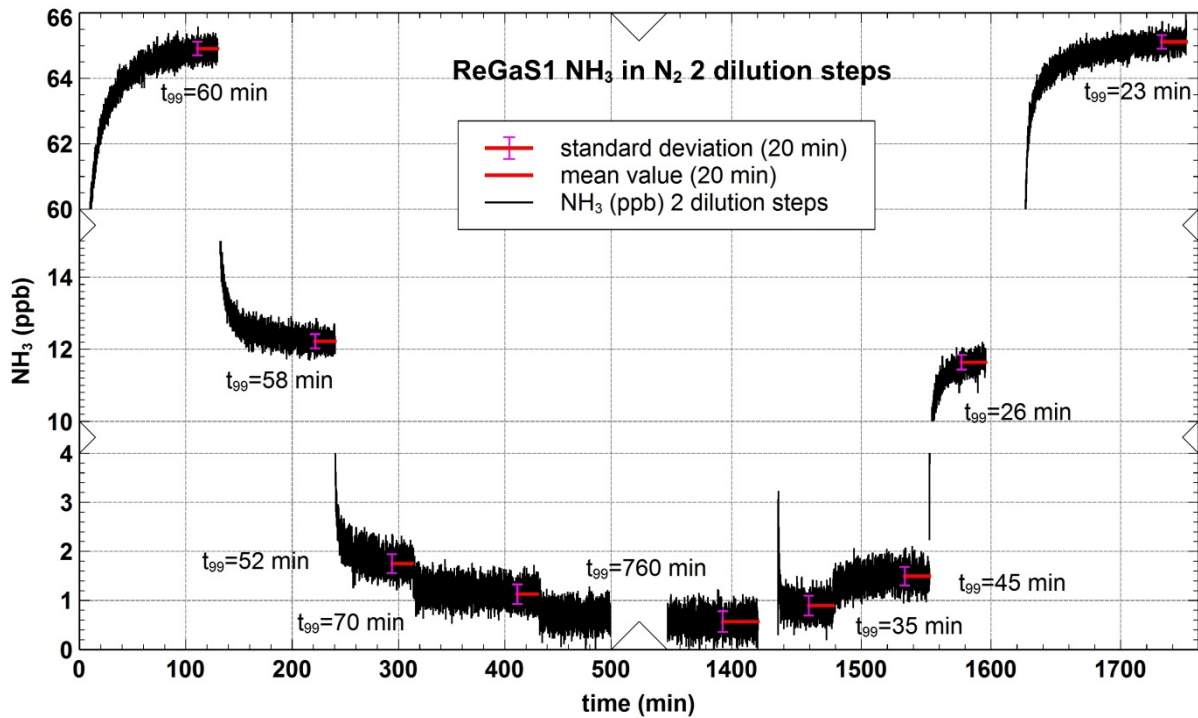

Figure 7: NH₃ amount fractions generated with two dilution steps. Note that the individual parts of the instrument at that time have not yet been calibrated. The time t_{99} which passed until amount fractions had reached 99 % of the final stable amount fractions was determined. It can be seen that for amount fractions generated with two dilution steps, the stabilisation time is considerably longer. This is to a minor extent due to the fact that the gas mixture containing NH₃ passes one MFC which has a considerable surface. Stabilisation times of ReGaS1 are generally very fast and are here considerably masked by the stabilisation time of the CRDS. They are very long since its surfaces are not SilcoNert2000 coated. The standard deviation over the last 20 min of every step was calculated. The standard deviation is smaller than the measurement noise of the CRDS (1 ppb).

Uncertainty budget for the dynamic generated mixtures

Since the generated NH₃ RGM is determined using various input parameters, the corresponding uncertainty has to be quantitatively estimated and reported. The uncertainty budget is established and calculated according to GUM guidelines using GUM Workbench Professional (ISO/IEC Guide 98-3:2008, *Uncertainty of measurement - Part 3: Guide to the expression of uncertainty in measurement*). It was the aim for the mobile reference gas generators to be able to generate NH₃ RGM 0.5 – 500 nmol mol⁻¹ at $U_{NH_3} \leq 3 \%$, ($k = 2$). The relevant input quantities are permeation rate (determined via the temperature and pressure dependent loss of mass over time) and gas flow and their associated uncertainties. A further relevant contribution, particularly for amount fractions requiring the second dilution step, is the purity of the matrix gas (figure 9).

ReGaS1 NH₃ reference gas mixtures: preliminary uncertainty budget

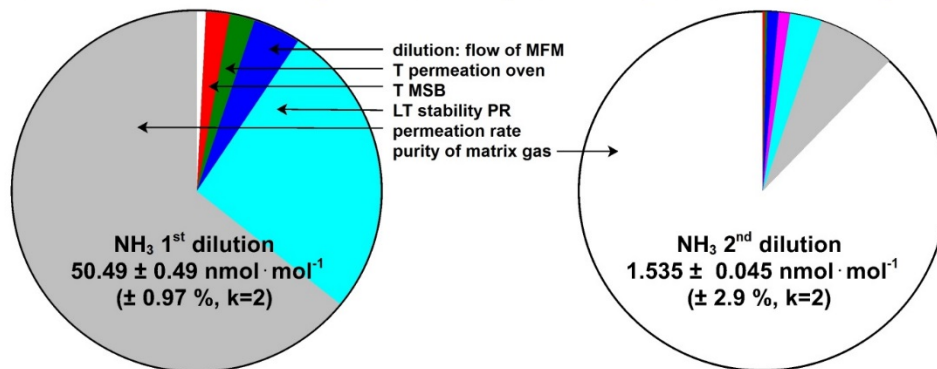

Figure 9: Relative contributions to the uncertainty budgets for RGM generated with ReGaS1. Left: One dilution step. Right: Two dilution steps.

Conclusions

A mobile reference gas generator (Reactive Gas Standard 1 - ReGaS1) was planned, constructed, characterised and validated successfully at METAS. It combines the temperature and pressure dependent permeation method with the dynamic dilution of the base mixture over two dilution steps. ReGaS1 can be used for the dynamic generation of 0.5-500 nmol mol⁻¹ with U_{NH₃} <3 % to calibrate optical instruments in the laboratory and in the field. Important prerequisites for stable and reliable generation with low uncertainties are stable ambient temperature conditions (± 0.5 °C optimal) and high-purity matrix gas. A second reference gas generator following the same principle was constructed at BAM.

3.2 Development and characterisation of optical transfer standards

3.2.1 Extractive OTS

An extractive, commercial cavity ring-down (CRDS) instrument by Picarro Inc. (Model G2103) with a detection limit ≤ 1 nmol mol⁻¹ was used by PTB as a starting point to develop an OTS. This included the following steps:

- Developing a spectral model that is fitted to CRDS spectra to perform absolute ammonia amount fraction measurements
- Developing a new spectral data evaluation routine that can include the uncertainties in the spectral model parameters in compliance with the GUM; in collaboration with DFM
- Calibration of CRDS instrument sensors
- Re-measuring required spectral parameters (line strengths) of ammonia with improved measurement uncertainty (see publication list, Pogány et al., 2016) to lower the measurement uncertainty of the OTS
- Metrological characterisation of the OTS: linearity, stability & drift, effect of ambient temperature changes, cross-interference; the latter in collaboration with REG(NERC)
- Performing validation measurements of dynamic reference gas mixtures; in collaboration with METAS
- Implementing the approach in a field comparison of ammonia analysers; in collaboration with REG(NERC)

Some of these steps are elaborated in the following:

Development of a Spectral Model

The commercial CRDS instrument serving as starting point of the OTS measures spectra in the near infrared at about 1.5 μm in a narrow spectral window, covering about 0.7 cm⁻¹. The spectrum is scanned at discrete wavenumber set points with a step size of about 0.02 cm⁻¹ yielding 36 (averaged) data points per spectrum. In Figure 10 we show a simulation of the scanned spectral region for typical measurement conditions in air, including the analytes ammonia (10 nmol mol⁻¹), carbon dioxide (400 μmol mol⁻¹), and water (10 mmol mol⁻¹). As one can see, the air spectrum is rather complex. The complexity of the spectrum, paired with the relatively sparse spectral sampling, made the development and regression of a detailed spectral model necessary. The spectral model that was developed for this purpose approximates the measured spectrum based on available and self-measured absorption line parameters and the Voigt profile¹. By restricting all model input parameters to available absorption line data, as well as measured temperature and pressure, and adjusting the amount fractions of ammonia, carbon dioxide, and water to yield the best fit of measured spectrum and spectral model, we can derive fitting results (ammonia amount fraction estimates) with an uncertainty in the low percent range.

The model includes overall 18 absorption lines and neglects weak lines which do not significantly contribute to the experimental spectra². In Figure 11, we show the spectral model, evaluated for typical measurement conditions.

¹ The restriction to the Voigt profile is due to the limited availability of line parameters which are required to describe higher order profiles. Computational speed when fitting higher order profiles may also become problematic.

² This restriction was a necessary compromise between model accuracy and computational cost when fitting.

In a collaboration of NPL and Picarro within the MetNH3 project (Martin et al., 2016, see publication list), water interference through broadening was identified as a potential source of bias. The water broadening contribution was therefore included in the model (the required broadening parameter was published by NPL and Picarro).

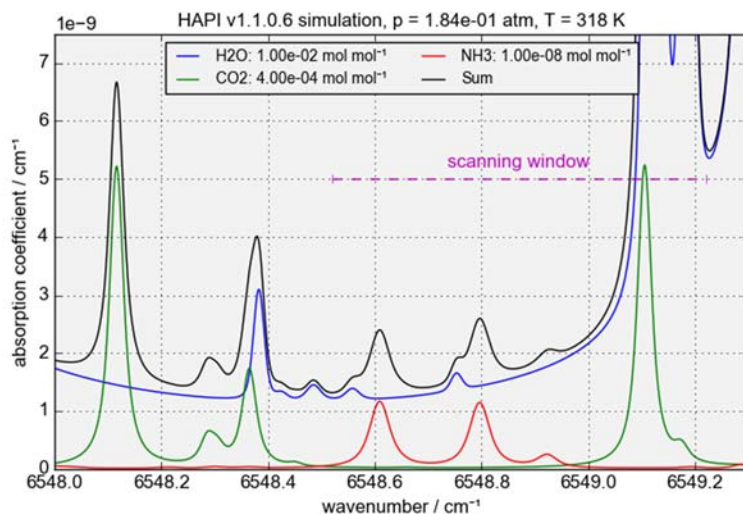

Figure 10: Simulation of an air spectrum containing 10 nmol mol⁻¹ ammonia, 400 μmol mol⁻¹ carbon dioxide, and 10 mmol mol⁻¹ water. The scanning window of the commercial near-IR CRDS instrument is indicated by a magenta line. The simulation was prepared using the HITRAN application programming interface³.

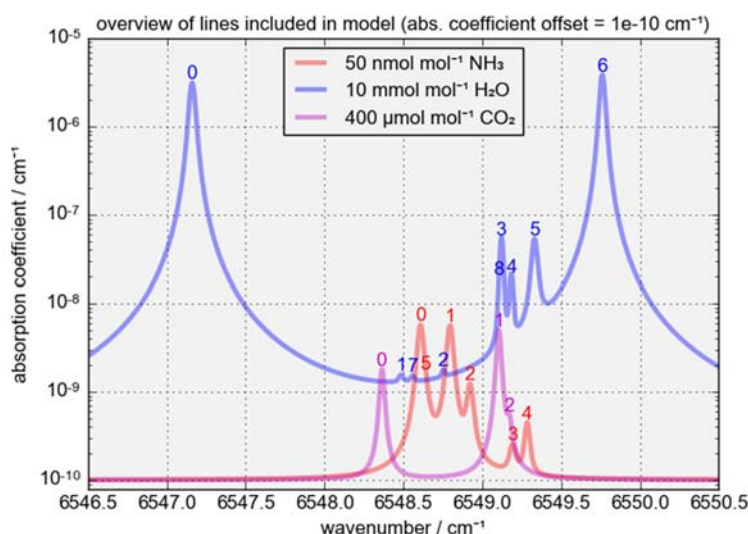

Figure 11: Spectral model, evaluated for typical measurement conditions. Absorption lines are labelled with a line index for identification.

Development of New Spectral Data Evaluation Routine

The spectral model requires a multitude of absorption line parameters as input. The uncertainty of these parameters, which describe the (pressure and temperature dependent) position, width, and intensity of the probed absorption lines, must be propagated to the final amount fraction results that are yielded by fitting the spectral model to measured CRDS spectra. The same is true for the input data that was measured by the CRDS instrument, i.e. temperature, pressure, and the CRDS spectrum. For this purpose, a general least squares fitting software that includes GUM compliant uncertainty propagation was provided by DFM. The fitting software, which is written in the programming language Python, was improved and extended during the

³ R.V. Kochanov et al., HITRAN Application Programming Interface (HAPI): A comprehensive approach to working with spectroscopic data, *J. Quant. Spectrosc. Radiat. Transfer* **177**, 15-30 (2016).

collaboration with PTB, and validated using reference data sets from NIST. PTB developed a software interface to DFMs fitting software to fit CRDS spectra. The developed software provides the metrologically relevant uncertainty figures, an uncertainty budget, and covariance of the OTS measurement results.

For each fitting result, the least squares software automatically performs an evaluation of the compatibility of fitting function (model) and measurement data, based on a chi-square test. The chi-square test is helpful to identify unusual measurement conditions. This is due to the fact that the spectral model can only be a good approximation to the measured spectrum if measurement conditions match the conditions for which the model was evaluated (e.g. pressure, temperature, matrix gas composition). Therefore, for example, significant cross-interference will lead to a failing of the chi-square test.

Calibration of CRDS Instrument Sensors

Pressure and temperature sensors of the OTS instrument were calibrated against traceable sensors, which is a prerequisite to performing traceable measurements. The accuracy of the wavenumber axis is another crucial factor. The wavenumbers reported by the instrument are indirectly verified due to the chi-square test. This is, similar as for measurement conditions, due to the fact that the spectral model cannot approximate the measured spectral data well if the reported wavenumbers are (too) biased. This was tested by systematically scaling the measured wavenumbers. Fitting with different scaling factors and evaluating the chi-square test confirmed that the reported wavenumbers should be accurate within 1 %. The wavenumber references for this verification are the (pressure-shifted) molecular transition wavenumbers.

Improved Spectral Parameters

The spectral parameters which usually constitute the highest contribution to the ammonia amount fraction are line strengths. Roughly speaking, these parameters quantify how much light is absorbed by a particular molecular transition (how intense an absorption line is) per unit concentration and are used in absolute laser-spectrometric measurements to translate the spectroscopic signal into the amount fraction.

By performing TDLAS measurements on pure ammonia, the line strengths of the three main ammonia lines probed by the CRDS instrument were re-determined. Compared to line strengths compiled in the popular absorption line database HITRAN, the results were found to be smaller by about 6 %, and the measurement uncertainty could be decreased by a factor of 3 to 10 to $U_{\text{rel}} = 1$ to 3% ($k=2$) (see publication list, Pogány et al., 2016).

Lower uncertainty in the ammonia line strengths is a key factor for improving the overall uncertainty of the OTS spectral data evaluation. The line strength of the two dominant ammonia absorption lines (labelled 0 and 1 in Figure 1) are still the most relevant parameters in the uncertainty budget, despite the improved uncertainty.

Metrological OTS Instrument Characterization (Selected Tests)

The **linearity** of the OTS instrument was confirmed by measuring a dilution series of ammonia in synthetic air, prepared from a pressure cylinder with $10 \mu\text{mol mol}^{-1}$ nominal amount fraction, see Figure 12. The R^2 value of a linear fit is very close to 1 (0.999953) indicating good linearity.

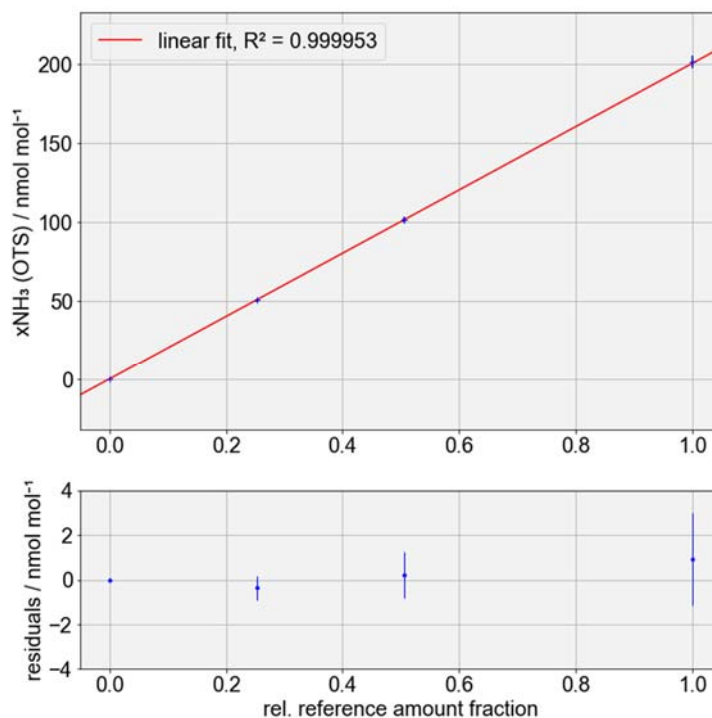

Figure 12: Linearity test of OTS. Reference gas mixtures were prepared by dilution from a pressure cylinder. By normalizing the prepared amount fractions to the highest prepared amount fraction, the (only nominally known) amount fraction of ammonia in the pressure cylinder cancels out. Assuming sufficient stability of the amount fraction in the pressure cylinder over a course of several days (duration of the linearity test), the linearity of the relative prepared amount fractions depends only on the linearity of employed mass flow controllers, which is better than 0.5 % according to manufacturer specifications. The experiment shows no obvious deviation from linear behaviour.

Cross-sensitivity to H₂O (a major concern for ambient measurements) was tested by performing measurements of dry and humidified gas mixtures prepared with the dynamic generators ReGaS1 (NH₃ in air) and PReHAGS (humidity in air), which are both outcomes of the MetNH₃ project. A piston flow calibrator was used as flow comparator to accurately balance flows when switching between dry gas mixtures and humid gas mixtures, such that the ammonia amount fraction provided to the instrument is not significantly altered. In Figure 13 we show three spectra which were measured when switching from dry conditions (red dots and trace) to humid conditions (green) and back to dry conditions (blue). For these measurements, we derived ammonia amount fractions of 60.2 ± 1.5 , 59.6 ± 1.9 , and 60.3 ± 1.5 nmol mol⁻¹, respectively ($k = 2$). The differences of the measured amount fraction for the dry measurements to the humid measurement amount to 0.6 ± 1.0 and 0.7 ± 1.0 nmol mol⁻¹, respectively, i.e. the difference is not significant for $k = 2$.⁴ Thus, from these measurements, no significant cross-interference to H₂O was found.

⁴ Note that the uncertainties of the amount fraction differences are somewhat smaller than the uncertainties of the measured amount fractions due to covariance of the amount fraction results.

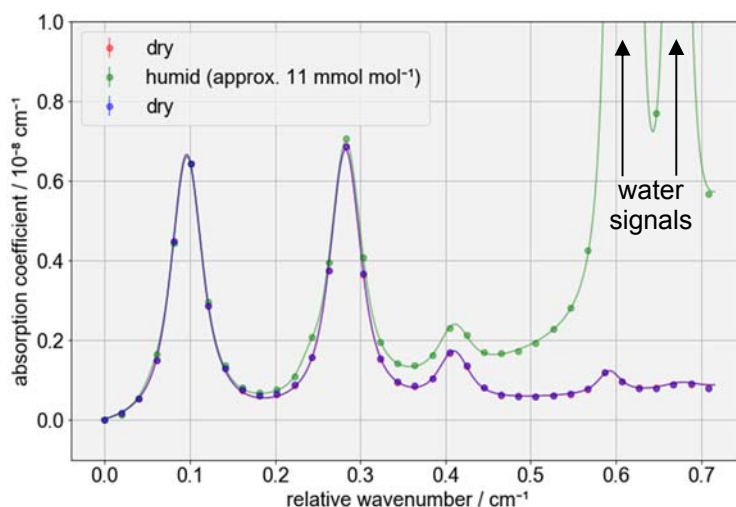

Figure 13: Measured CRDS spectra (dots) and fitted models (lines) from humidity cross-interference tests (measured in succession). The water amount fraction was about 11 mmol mol⁻¹ in the humid measurement.

Cross-sensitivities to compounds other than H₂O were also investigated. Trace levels of NO, O₃, and SO₂ (about 0.1 μmol mol⁻¹) did not significantly affect OTS measurement results (measured at about 16 nmol mol⁻¹).

Validation measurements using dynamic reference gas mixtures

OTS measurements were performed with dry reference gas mixtures supplied by the portable reference gas generator ReGaS1, a permeation-based dynamic transfer standard developed by METAS in the course of the MetNH3 project. Measurements were done over the course of 5 months, during joint measurement activities of PTB and METAS. For each comparison measurement, care was taken to allow long enough stabilization time.

In Figure 14 we show the deviation of OTS results to reference values provided by ReGaS1. A linear fit of the data reveals an average deviation of about + 6 % ± 1 % from OTS results to ReGaS1 reference values. Only for one measurement at about 50 nmol mol⁻¹, we find the OTS results and the reference value to be metrologically compatible for the coverage factor $k = 2$. This points at some overlooked bias, either on the OTS or generator side or also on both sides. The relatively high variance in the agreement of OTS results and reference values may point at sampling artefacts.

From the ReGaS1 measurements we also compared OTS results to results derived from the factory calibration of the instrument. The deviation was found to be + 1.1 % ± 0.4 % plus an offset of 0.93 ± 0.05 nmol mol⁻¹, i.e. the results agree rather well.

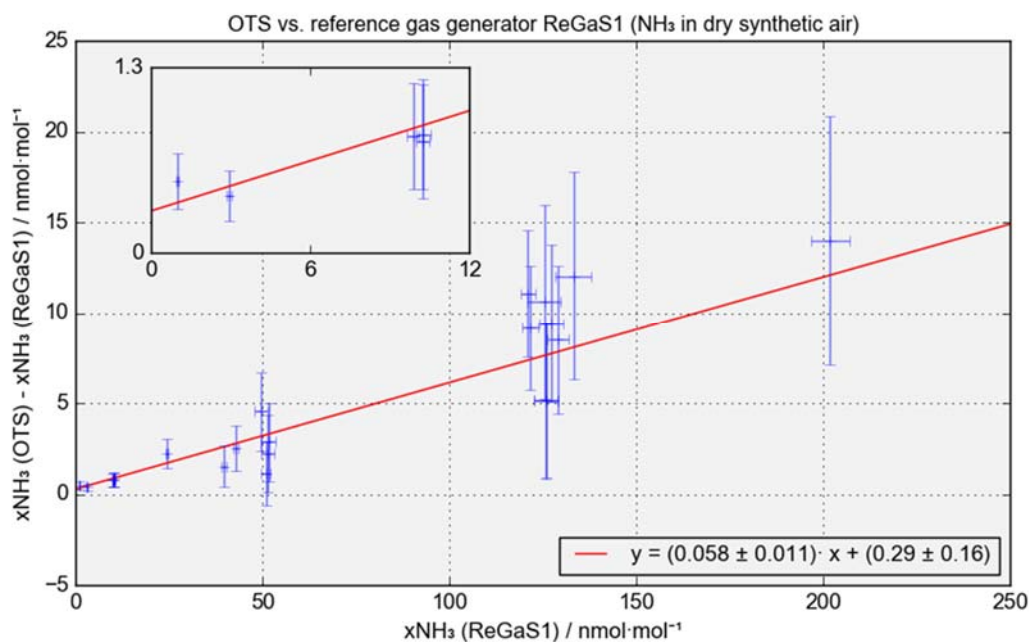

Figure 14: Plot of ReGaS1 reference values vs. difference to OTS results

Field trial

The OTS was part of the MetNH₃ field campaign held on a field side close to Edinburgh, Scotland, in August 2016. OTS results and metadata were analysed to derive the instrument performance under field conditions. Also, OTS results were compared against the CRDS instrument factory calibration (Figure 17). The factory calibration included a new water correction which was a result of the NPL/Picarro collaboration mentioned above. The comparison, performed only on data where the ammonia amount fraction was rather stable (amount fraction ≤ 50 nmol mol⁻¹) shows that OTS results and the factory calibration deviate only by a small offset of about 0.28 nmol mol⁻¹ and scale almost equally, i.e. the agreement is very high. The instrument temperature and pressure stabilisation were found to perform well under field conditions, as shown in the time series and histograms in Figure 15, despite significant variations (up to 25 °C) of the ambient temperature.

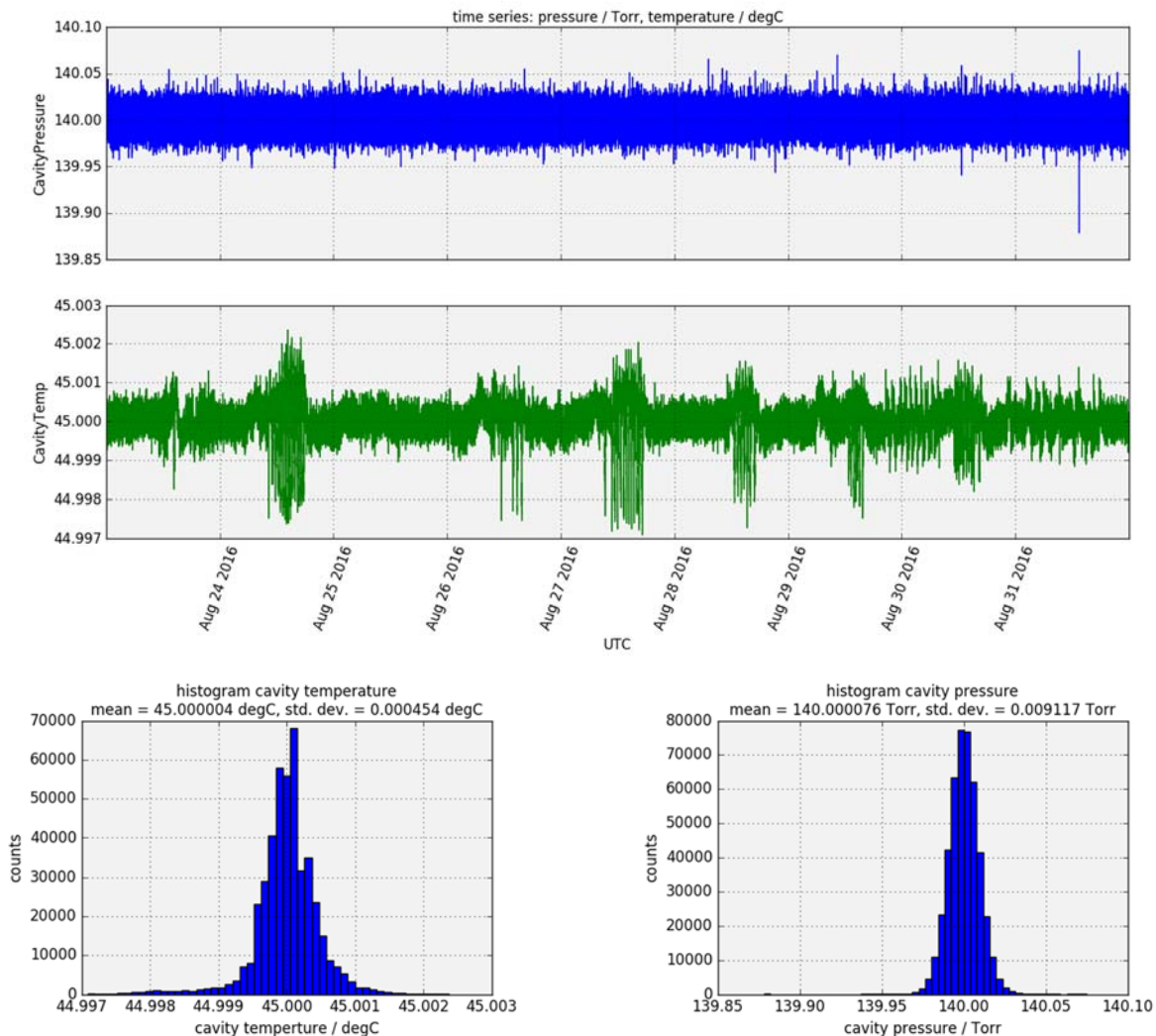

Figure 15: Top – time series of CRDS cavity pressure (blue) and temperature (green) during field trial. Bottom – associated histograms.

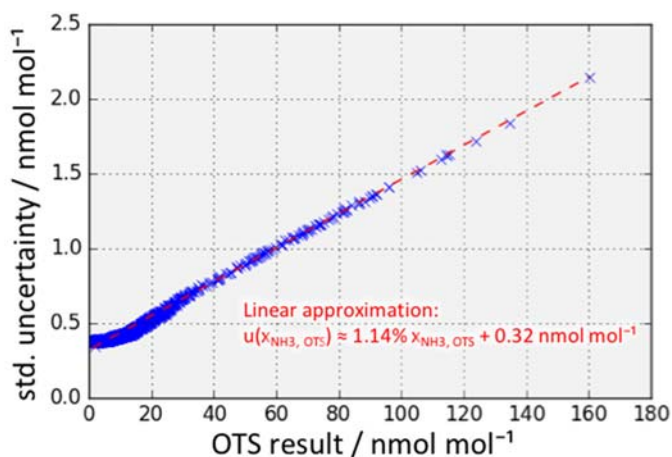

Figure 16: Uncertainty of OTS results from field trial.

From a plot of the OTS results versus the associated standard uncertainties (Figure 16), we find that 1.14 % plus 0.32 nmol mol⁻¹ is a reasonable approximation of the standard uncertainty. This was derived for amount fractions ranging from about 1 to about 160 nmol mol⁻¹ with a time resolution of 5 minutes (spectra averaged in 5 minute windows). The lower uncertainty bound (0.32 nmol mol⁻¹) is due to limitations in the spectral model and spectral noise.

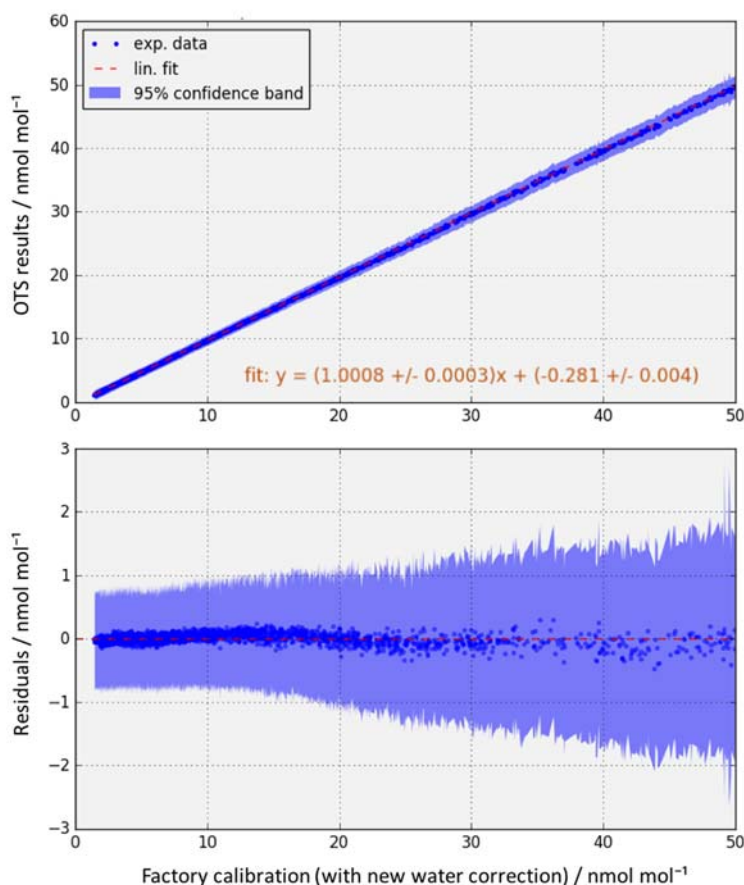

Figure 17: OTS results vs. factory calibration from measurement results of the field trial.

Concluding Remarks: Extractive OTS

The presented research demonstrated that an OTS for ammonia in air which performs absolute laser-spectrometric amount fraction measurements may be derived from commercial instrumentation. New software tools were developed to enable the evaluation of complicated and sparsely sampled spectra. The software provides GUM compliant uncertainty figures, an uncertainty budget, covariance, and performs a chi-square test which serves as a quality check to evaluate spectral model and measurement data compatibility. The data evaluation method is not restricted to the OTS developed in MetNH3 and may be applied to other spectrometers and analytes.

Molecular parameters required for the spectral data evaluation were measured with improved uncertainty, enabling OTS fitting results in the low percent range. Cross-interference to H₂O and other trace gases was not found to be significant. Linearity was found to be high. Stability under field performance in terms of gas properties was found to be only slightly worse than under laboratory conditions, but not affecting the measurement results.

Despite these positive findings, the objectives described in Section 2.3 can only be viewed as partly fulfilled. Traceability of the extractive OTS is so far prevented due to the fact that traceable measurement results for several molecular parameters which enter the spectral model are not available. This concerns most air broadening coefficients of the probed ammonia lines which constitute a significant fraction of the overall uncertainty budget. Also, a verification of absorption coefficients measured by the CRDS instrument was so

far not possible. The comparison to the generator ReGaS1 indicates furthermore a significant bias, for which the source could not be identified, and significant variance, potentially through sampling, which is so far not included in the uncertainty budget.

Nevertheless, the work done in the project provided new tools for uncertainty propagation in spectral data evaluation, applicable also beyond the MetNH3 project, and improved spectral line data. The performed characterization demonstrates that the extractive OTS instrument is a solid basis for a traceable spectrometer, and critical developments towards traceable measurements were achieved. Remaining limitations have to be removed in future endeavours. Most importantly, the source of the bias to ReGaS1 must be identified.

3.2.2 Sampling-free OTS

VTT developed an open-path spectrometer based on quantum cascade laser absorption spectroscopy (QCLAS) and open-path multipass setup. The sampling-free approach eliminates measurement inaccuracies related to ammonia adsorption on surfaces on extractive measurement systems. A schematic picture of the developed instrument is shown in Figure 18:

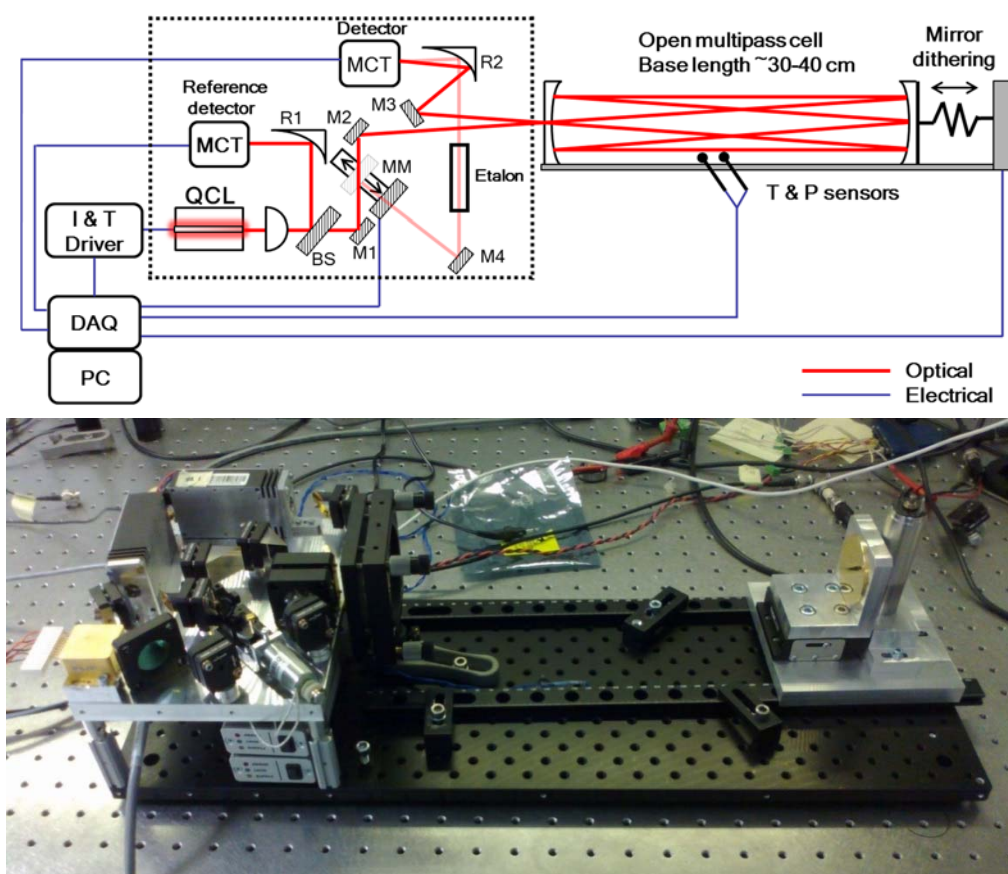

Figure 18: Top – Schematic picture of VTT's sampling-free spectrometer. DAQ: data acquisition card, PC: computer, I & T: laser current and temperature driver, QCL: quantum cascade laser, BS: beam splitter, M1-M4; mirrors, MM: moving mirror, R1-R2; off-axis parabolic mirrors; MCT; mercury cadmium telluride detector, T & P: ambient temperature and pressure sensors. Bottom – Photograph of sampling-free spectrometer.

The mid-infrared (MIR) beam exiting a quantum cascade laser (QCL) is coupled into an open path Herriot type multi-pass cell which has a base length (d) of 34.45 cm and an optical path length (L) of 17.248 m. The radius of curvature (R) of the mirrors is 60 cm. The cell is equipped with traceable temperature, humidity and pressure sensors (Vaisala Combined Pressure, Humidity, and Temperature Transmitter PTU300). The wavelength tuning range of the QCL is calibrated using a solid Ge-etalon. The acquired detector (MCT) signal is processed in real time with a custom MATLAB software algorithm.

The instrument probes strong ammonia fundamental absorption lines in the mid-infrared (MIR) which enhances its sensitivity down to the required nmol mol^{-1} levels. The targeted absorption features are a manifold of six lines at about 1103.5 cm^{-1} (see Figure 199). Line data from the HITRAN database (2012 edition) is employed in the spectral data evaluation.

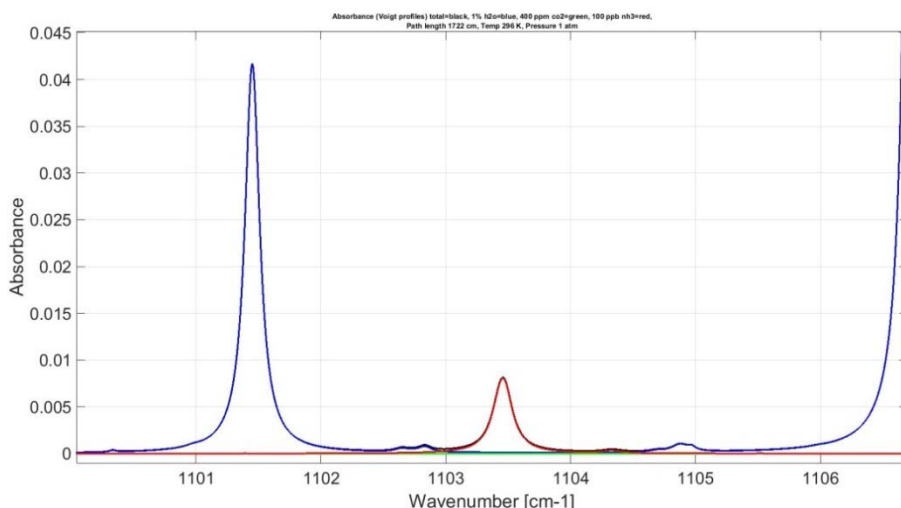

Figure 19: Simulation of 100 ppb ammonia (red line) spectrum with the presence of 1 % water (blue line), 400 ppm CO₂ (green line).

Validation of the accuracy of the measured ammonia amount fractions was done by measuring gas mixtures with varying ammonia amount fractions in the 0 - 250 nmol mol^{-1} range. Ammonia samples were prepared by an evaporation method where known ammonia/water gas mixtures are mixed with compressed ambient air. The uncertainty of the ammonia amount fraction in the prepared mixtures is 1.4 %. The calibration curve in Figure 20 shows the response of the spectrometer as a function of the ammonia amount fraction. The generated ammonia concentrations were measured and confirmed with a Picarro NH₃ analyser, which was calibrated against the extractive OTS developed at PTB.

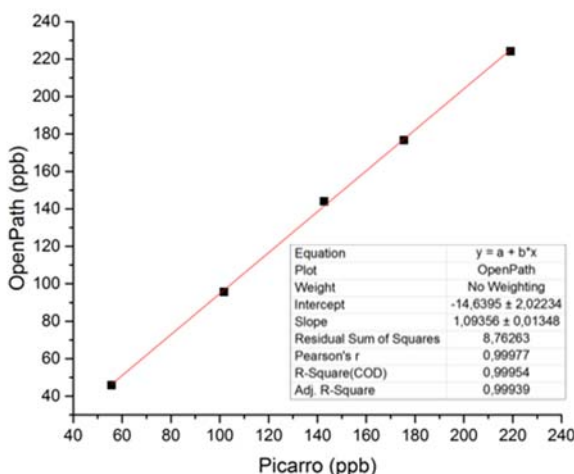

Figure 10: calibration curve of the open-path analyser. The solid red line is linear least-squares fit.

The typical standard deviation of the measurement signal was 2.5 ppb with 1 s measurement interval. However, there is about 5 ppb offset in the open-path signal compared to the Picarro analyser within the whole measurement range. As conclusion, a detection limit of 5 ppb in 1 s (2σ) was reached with the open-path

analyser. However, the real minimum detection limit of the spectrometer was rather around 40 ppb, limited by the fitting routine. The limited tuneability and unstable behaviour of the QCL and especially open-path Herriot cell construction caused background fluctuations and fitting errors with the small ammonia concentrations (below 50 ppb). This is also the major source of uncertainty in the measurement.

Spectral interference of water vapour to the measurement was taken into account by measuring the absolute water concentration using a humidity sensor and fitting overall 13 water lines simultaneously in the measured spectrum. Water absorption does not affect to the ammonia measurement itself which is demonstrated in Figure 21, where the water concentration is not seen to affect linearity even though it is varied between 0.3 and 1.1 %.

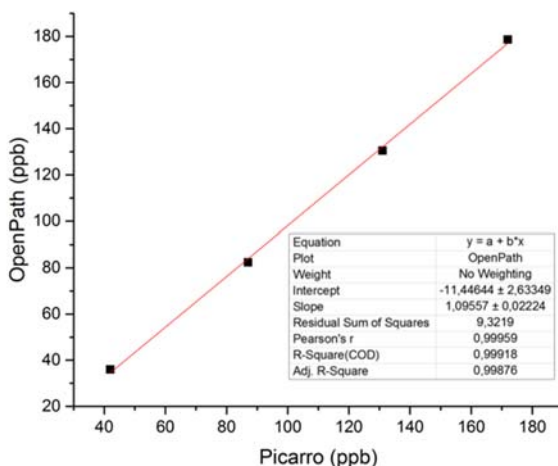

Figure 11: A calibration curve of the open-path analyser with varied water concentration. The water concentrations from lowest to highest ammonia concentration were 0.3, 0.5, 0.8 and 1.1 %, respectively. The solid red line is linear least-square fit.

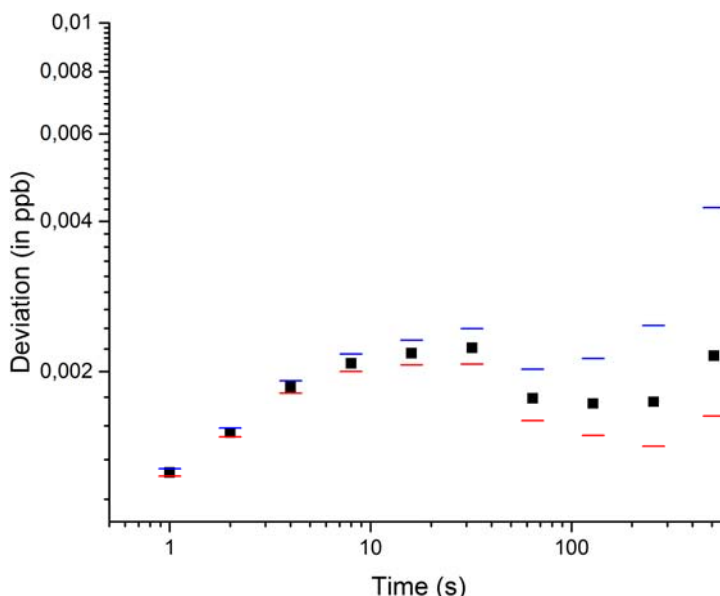

Figure 12: Allan deviation of the open-path spectrometer measured at 45 ppb of ammonia

The stability of the spectrometer was investigated by determining the Allan deviation from measurements with an ammonia concentration of 45 ppb. Figure 22 shows a typical Allan deviation plot of the system. It shows

that there is some low frequency fluctuations probably due to the unstable QCL signal and Herriot cell which are preventing longer averaging times.

Concluding Remarks: Sampling-free OTS

A sampling-free spectrometer was developed and validated during the project. Even though problems with spectral fitting due to unstable operation of the selected laser module and constructed optical setup were encountered, limiting system sensitivity at ammonia concentrations below 50 ppb, the system gave clear evidence for the applicability of a sampling-free spectrometer as OTS for reactive molecules like ammonia. By fitting the spectrum using high quality spectrum parameters it is possible to perform an absolute measurement with no need for calibration with reference gas or use of a separate sampling system and sample gas transportation or filtration. System response time was in practise instant over several orders of magnitude (2 – 3 orders of magnitude tested) in concentration. Consequently, this enables also to fully benefit from inherent linearity of laser spectroscopic method over several orders of magnitude (at least 4 – 5 orders of magnitude). Compared to extractive systems where it is common to measure T90 time (rise time 90 % of final value) in minutes this is a tremendous advantage especially in case high concentration peaks of ammonia are expected. Due to limited possibilities for calibration and background measurement in an open-path device system, stability is an essential property. In this aspect, further development is needed for the constructed spectrometer.

3.3 Establishing the transfer from high-accuracy standards to field applicable methods

3.3.1 Inlets and aerosol testing

Ammonia is a sticky molecule that readily interacts with water, acids and aerosol phase chemicals both in the atmosphere and on surfaces.

Ammonia monitoring systems will typically have a length of inlet, potentially a filter (either externally, internally or both). There are fittings and connections, which transition between the inlet and the internal plumbing of the analyser, which often result in pressure changes between the inlet and the inside of the instrument.

The focus of this work is on developing a systematic, practical approach to quantify effects of inlet material and aerosol loading on instrument response: what performance can reasonably be expected in during field deployments, what might the best inlet material be and are 'aged inlets' appropriate?

Potential effects that may be observed include:

1. Equilibration with relative humidity and temperature – enhanced adsorption or desorption as a function of time
2. Aerosol impaction on the inlet walls – chemical interactions and water thermodynamic equilibrium will change

Inlet surface material properties will change as a function of time. To assess the breadth of experimental set ups, a questionnaire was sent to the ammonia monitoring community in spring 2015 and the results informed the preparation of coated inlets. The three most critical selection parameters for the inlet types are: material, diameter and length.

Material: 71 % of responses used some form of Teflon plastic, as such both PTFE and PFA were selected for testing. 25 % responses use a form of stainless steel; SilcoNert2000 coated stainless steel was chosen as this is designed specifically to be low adsorption surface. Also selected, was LDPE as this is used effectively in low-cost passive samplers, for low adsorption and low cost.

Diameter: 53% respondents used either ¼" OD or 4mm ID tubing, as such all tubing used during testing is ¼"OD (4mm ID).

Length: The length of inlets used by the community range from a few centimetres to 50m. 44 % respondents use an inlet length between 1-5 metres, whilst 75 % use an inlet of 5 metres or less. For the testing, we have chosen a length of 2m as a compromise.

Four test aerosol coatings were also selected: Sodium Chloride – sea salt aerosol fraction, ammonium nitrate, ammonium sulphate and humic acid sodium salt – proxy for organic aerosol fraction.

The inlets were connected to the NPL CATFAC (Controlled Atmosphere Test Facility), providing a constant source of ammonia (~10ppb) at a constant humidity (70 %). The inlets were substituted into the sample line of

the Picarro. An example of the response curve of the instrument with three different clean inlet materials is shown in Figure 23. Though the switch from the direct sampling to sampling through the 2 m length of inlet was rapid, a short burst of external air has led to some challenges in data interpretation. The initial results show that under the conditions there is a significant response time due to equilibration with the inlet surfaces and that some aerosols increase the response time. Methods for quantifying the response time are being assessed. Also the potential for developing a switching valve to investigate this process with CATFAC further are being considered. However these experiments were successful as the first demonstration of the potential for ambient aerosol to systematically change the response time and measurements of instruments in the field.

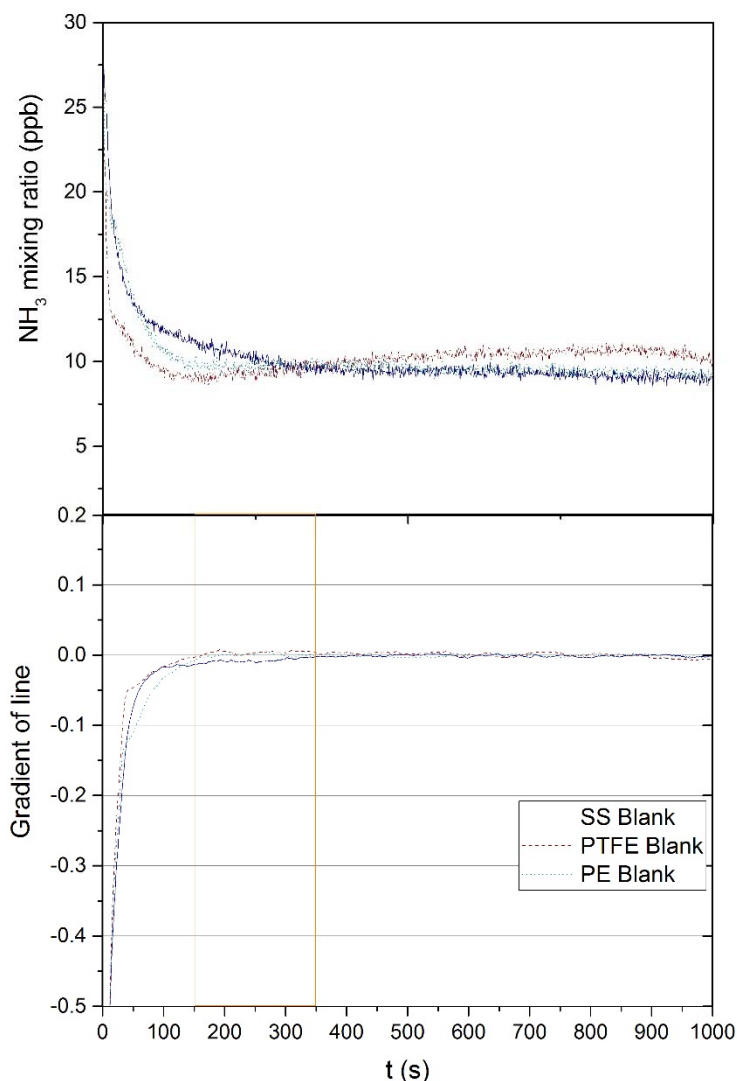

Figure 133: Response curve of the NPL CATVAC Ammonia Chamber with SS, PTFE and PE inlet materials

3.3.2 Designing a relative humidity and aerosol generator for testing instrument responses

Ammonia interacts strongly with atmospheric water and also with ambient particulate matter (also termed aerosol or PM). Inlet (and instrument) surfaces and ambient aerosol effects on ammonia metrology techniques are frequently the limiting factor for instrument response and quantitative measurement of ambient ammonia concentrations. However this interference with the quantitative measurement of ammonia is very poorly documented and in particular indicative response characterisation of instruments with typical background aerosol concentrations and relative humidities is not routinely checked or reported.

At the CEH (Centre for Ecology and Hydrology), NERC constructed and checked the tools necessary to develop an interactions assessment which would improve metrology of ambient ammonia measurements and

data quality assurance. In normal operations an instrument would be calibrated with a pure ammonia standard using a certified gas cylinder or using a traceable dilution system. For the interactions assessment a system response characterisation could be undertaken where likely aerosol effects can be checked with a known aerosol and RH combinations. Used systematically this could allow intercomparison of the performance of different systems and given a partly traceable measure of response characteristics.

A mobile aerosol flow tube - mixing system for systematic introduction of aerosol to sample flows was developed for instrument testing. The Portable Relative Humidity and Aerosol Generation System (PReHAGS) (Figure 24) was designed for the calibration and testing of ammonia monitoring analysers in both laboratory and field conditions. The system is able to generate and deliver aerosol in variable concentrations over a wide relative humidity range, in order to test the efficacy of the analysers to monitor ammonia under these conditions.

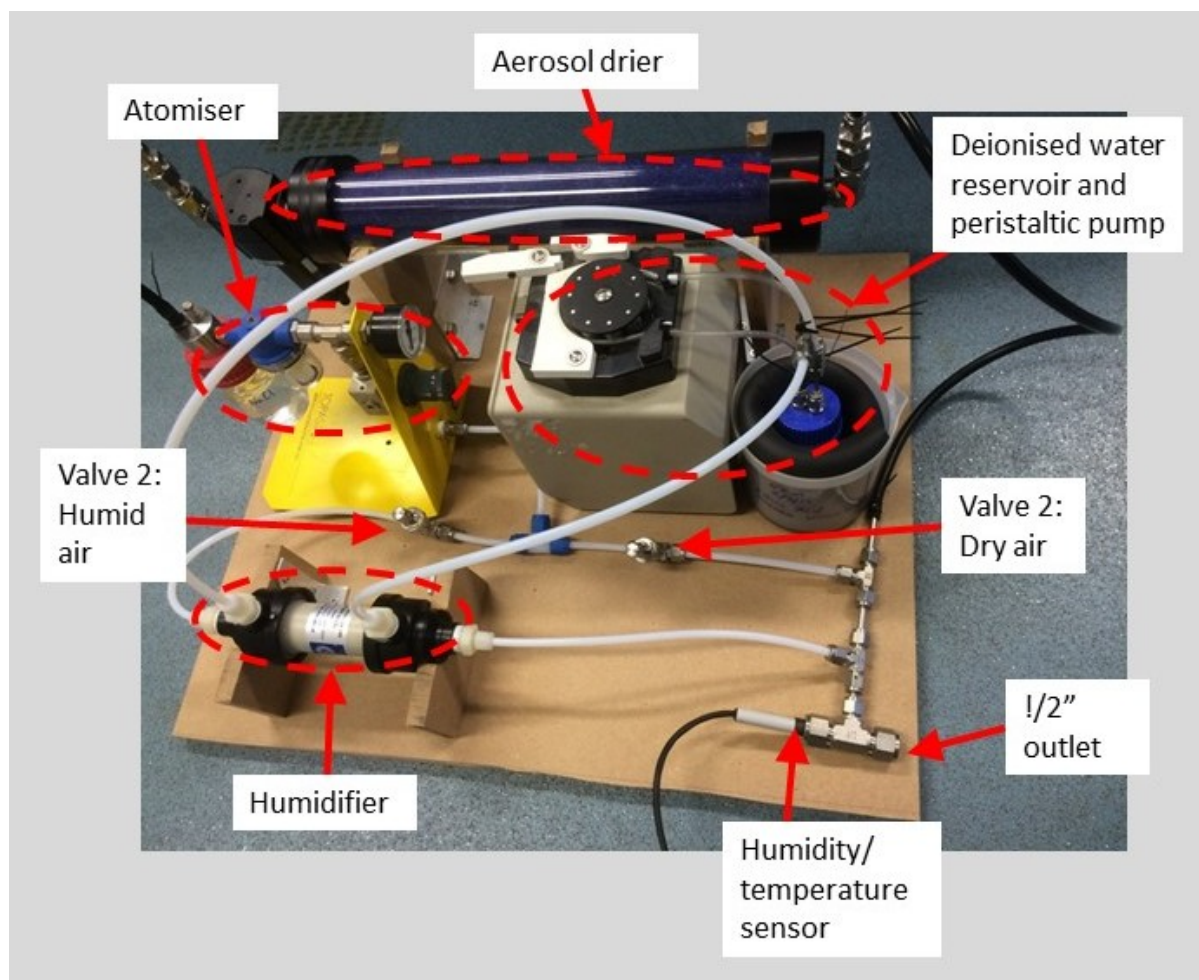

Figure 24: Portable Relative Humidity and Aerosol Generation System (PReHAGS)

The PReHAGS system was tested in the laboratory and results indicate that the system is capable of delivering aerosol mass in the range of 0-100 $\mu\text{g m}^{-3}$ with total flows up to 15 slpm and a RH range of 10 – 90 % at 20 °C.

Testing in the laboratory was primarily undertaken with sodium chloride (NaCl). A summary of results with three different NaCl solution concentrations (100, 500 and 1000 ppm) are shown in Table 3. The system reproducibly produced aerosol and by varying the solute concentration the mass output and particle size can be varied, with an approximately linear increase in particle mean diameter as a function of solution concentration at constant pressure. Also aerosol mass load in the output flow increases with both solution concentration and atomiser pressure, allowing a reproducible set of conditions which should allow the setup to be used in the field. Depending on the target for the specific experiments or characterisation being done, settings can be used to indicate the approximate characteristics of the aerosol composition delivered with

varying sodium chloride solution concentrations and atomiser outlet pressures at sample flow rate of 15 slpm. Other solutes and flow rates should be characterised depending on the intended characterisation. The PReHAGS system developed within MetNH₃ is a prototype system which would be applicable for laboratory application.

Table 3: Aerosol characteristics for solutions of sodium chloride at different atomiser outlet pressures. Measurements were made using a TSI 3936 SMPS. The range from 3 repeat measurements is given.

[NaCl] _{aq} (ppm)	Particle diameter (nm)		Aerosol mass range (µg m ⁻³) as fn of P _{atomiser} (bar)				
	Median	Mean	2.0	2.5	3.0	3.5	4.0
100	35.2-37.4	40.7-44.7	2.0-2.5	4.0-4.5	6.0-6.6	7.3-7.7	8.7-10.9
500	39.8-42.0	49.5-51.6	9.6-12.0	17.2-18.7	28.2-29.6	38.2-39.8	44.6-45.6
1000	42.7-45.1	55.0-57.5	28.9-30.2	47.0-53.5	54.1-59.6	73.2-79.4	89.7-101.1

3.3.3 Evaluating existing instrument and setups for traceable measurement of ammonia at ambient molar fractions (0.5 to 500 nmol mol⁻¹) under real air and artificial conditions (CATFAC)

As part of the planned NH₃ sensor validation programme, NPL’s Controlled Atmosphere Test Facility (CATFAC) was commissioned in the early stages in MetNH₃ and employed for the first systematic exposure testing of ambient ammonia passive samplers. Seven 28-day exposure tests at different concentrations with ALPHA, Gradko, PASSAM and Radiello diffusive samplers (14 days), and DELTA denuders. The exposed samplers were returned to the different manufacturers for analysis. Figure 25 shows the percentage deviation reported by each participant from the known traceable concentrations of NH₃. Some measurements were in good agreement with the known traceable reference concentrations while other devices exhibited over-reading and under-reading thereby clearly demonstrating the need for this validation work to be carried out.

The results were employed to **determine new values of the diffusive sampling rates for the devices tested**. Table 4 summarises the provisional data obtained. This work has provided the tools to improve the chain of traceability for low concentration ambient measurements of ammonia.

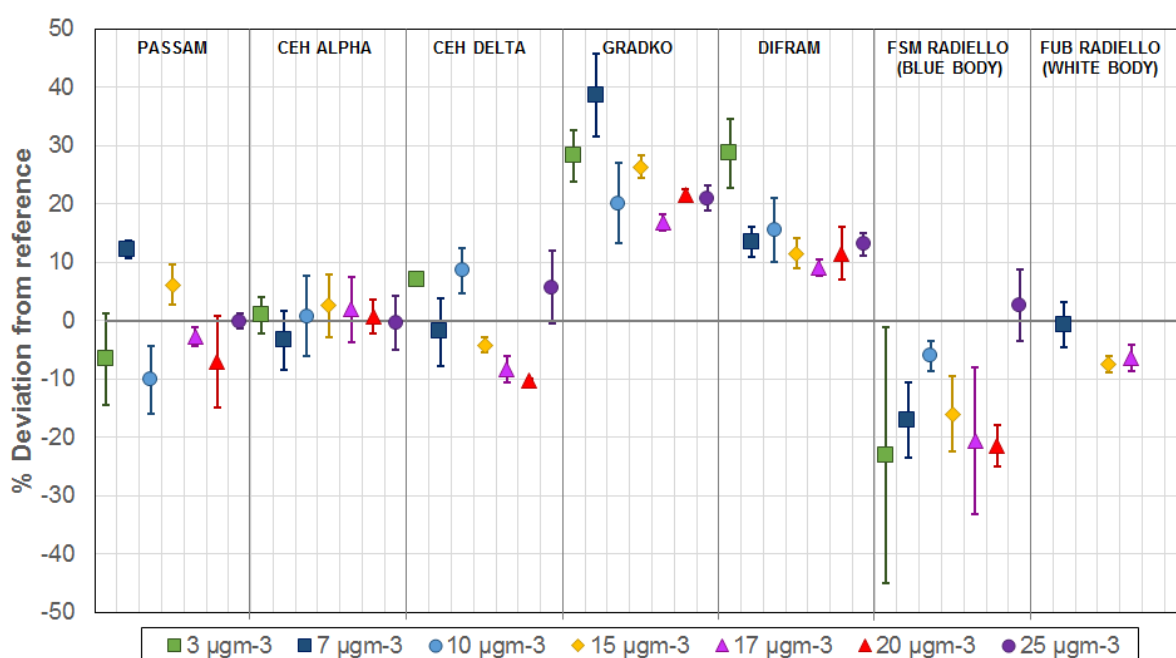

Figure 25: Summary of the mean of the reported NH₃ concentrations for diffusive and pumped samplers tested in the CATFAC, expressed as a percentage deviation from the reference values.

Table 4: Summary of NPL CATFAC measured and manufacturer diffusive sampling rates of NH₃ passive samplers.

Manufacturer	Diffusive sampler	Sampling Rate (this work), $\vartheta / \text{m}^3 \text{h}^{-1}$	R ² Value	Reference temp. (this work), /°C	Sampling rate (manufacturer data), $\vartheta / \text{m}^3 \text{h}^{-1}$	Reference temp. (manufacturer data)/ °C
CEH	ALPHA sampler	$(3.51 \pm 0.23) \times 10^{-3}$	0.999	20 ± 1	3.45×10^{-3} 3.24×10^{-3}	20 10
Gradko	3.5 cm diffusion tube	$(2.01 \pm 0.11) \times 10^{-4}$	0.997	20 ± 1	1.62×10^{-4}	20
Gradko	DIFRAM-400	$(3.17 \pm 0.18) \times 10^{-3}$	0.997	20 ± 1	2.82×10^{-3}	20
PASSAM	Passam ammonia sampler	$(1.85 \pm 0.16) \times 10^{-3}$	0.990	20 ± 1	1.89×10^{-3}	20
Istituti Clinici Scientifici Maugeri (ICS Maugeri)	Radiello sampler (standard blue body)	$(1.14 \pm 0.12) \times 10^{-2}$	0.986	20 ± 1	1.37×10^{-2} 1.41×10^{-2}	20 25
FUB	Radiello sampler from ICS Maugeri (white body)	$(1.29 \pm 0.13) \times 10^{-2}$	0.999	20 ± 1	1.37×10^{-2} 1.41×10^{-2}	20 25

3.3.4 Evaluating and comparing results produced with field measuring methods: Passive sampler intercomparison

Currently there is no regular quality assurance programme for ammonia passive samplers despite widespread use of these samplers across Europe and the rest of the world. In order to improve standards and begin to embed quality assurance in the measurement of ambient ammonia using passive samplers, within MetNH₃ a passive sampler intercomparison was planned to enable side-by-side exposure of the samplers to varying levels of ammonia in the field. From this experiment and in parallel the NPL CATFAC experiment also within Work Package 3 of MetNH₃, sufficient information and protocols could be developed. The method and infrastructure developed will then be available for future studies. The aim of the intercomparison exercise was to:

- 1) develop the equipment to compare different passive samplers

- 2) deploy the equipment to the Whim Bog ammonia line source site
- 3) expose ammonia passive samplers simultaneously at different points which are exposed to significantly different ammonia concentrations
- 4) at one point measure NH₃ using a well-calibrated continuous automatic instrument in parallel to passive samplers.

All the passive samplers taking part in the study were simple and easy to use. Clear and easy to understand instructions were provided by all suppliers. Shelter design was for most a similar principle. Feedback from the field deployment and staff suggestions for improvements were provided. All samplers were exposed in triplicate. The majority of laboratories returned data from the triplicate samplers with a precision of better than 15 % (as defined as the relative standard deviation (SD) of the three measurements). Where issues were observed it was at either high NH₃ (12 m point) or very low NH₃ concentrations (ambient). These issues can potentially be understood from sampler saturation at the high levels, analysis method limit of detection at low levels and occasionally dilution errors.

For QA, laboratory and transport blanks were included in the intercomparison. The final part of the intercomparison was the distribution of standard solutions. The high resolution NH₃ instrument (AiRRmonia) was deployed at the 32.5 m point to give the hourly concentration of NH₃ for comparison. The passive sampler intercomparison result is summarised in figure 26. Recommendations include that end users apply temperature specific uptake rates to ambient measurements and consider particulate background levels and meteorology.

Further QA exercises using the methodology developed here are being rolled out for annual national and international use by CEH.

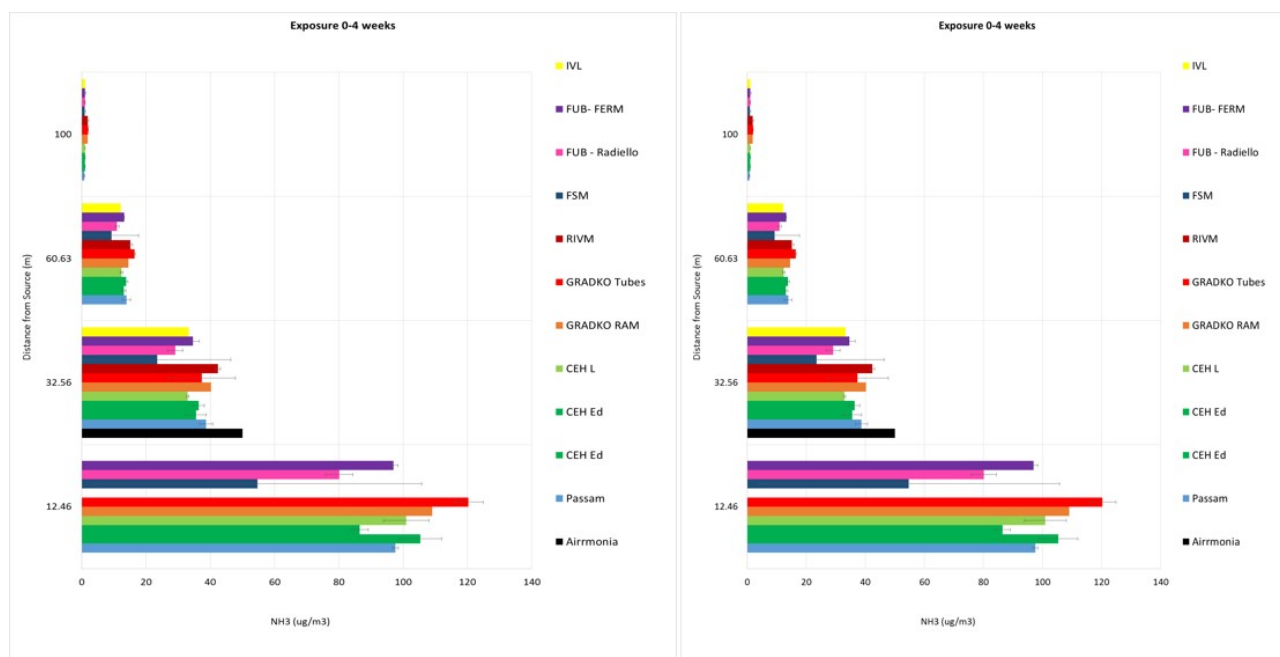

Figure 26: Results from passive sampler intercomparison, LHS: Week 0-4; RHS: Week 4-8

3.3.5 Evaluating and comparing results produced with field measuring methods: Active sampler intercomparison

The Easter Bush NH₃ intercomparison deployed 16 instruments and samplers over the period of one month (15th August – 16th September 2016) at an intensively managed grassland. Technologies included absorption spectrometry, DOAS and wet chemistry methods. A commercial CRD instrument was identified as a potential traceable method through MetNH₃ calibrations and characterisation in the MetNH₃ partner PTB and NPL laboratories. During the campaign both ambient and elevated NH₃ conditions were experienced with concentrations ranging between <1-300 ppbv.

METAS- and PTB-developed portable calibration systems were deployed and field tested during the intercomparison. Challenges with inlets, ambient conditions and practical logistics were overcome and most instruments were compared against the calibration systems at the beginning and end of the experiment.

For higher resolution measurement methods an NH₃ intercomparison was held at an intensively managed grassland in south east Scotland from the 21 August 2016 to the 1st September 2016. In total 15 participants, including SMEs, Regional and national institutions and MetNH₃ project partners took part in the intercomparison and 10 different measurement technologies were applied. Several techniques were replicated but with different field set-ups, which has allowed an assessment of the effect of set-up on ammonia measurement to be undertaken. A provisional summary of the ammonia concentration measurement made over the full intercomparison period by all instruments is shown in figure 27. It is expected that a peer-review publication will be submitted.

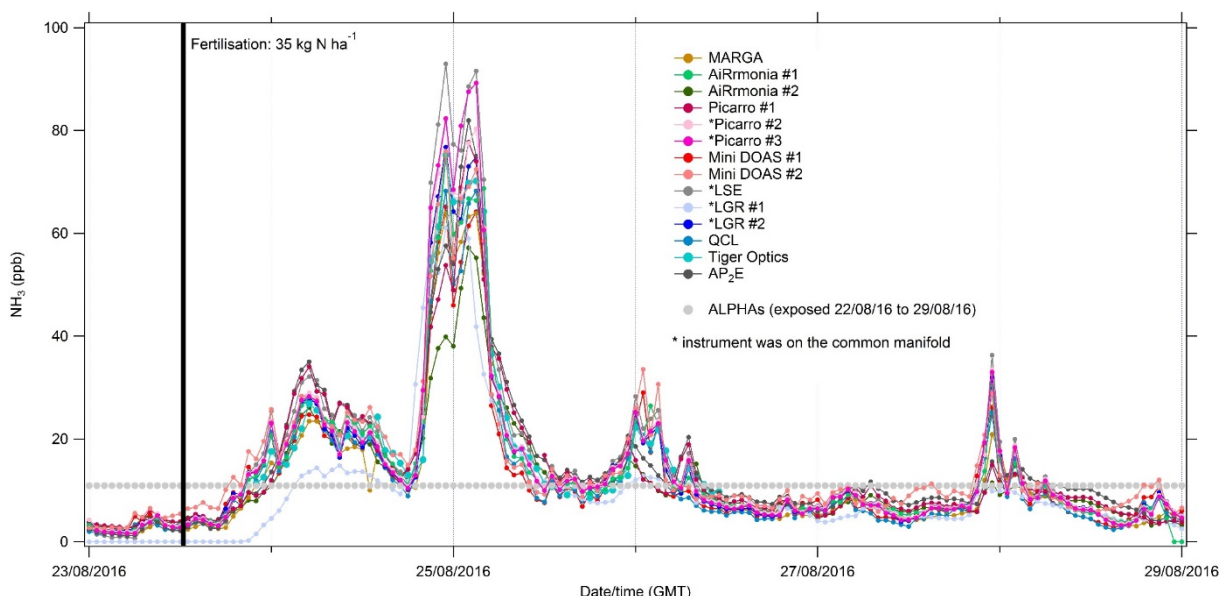

Figure 27: Summary of results from field intercomparison 2016

3.3.6 Protocols to promote long-term efficiency monitoring of ammonia reduction measures

Ammonia is released into the atmosphere in significant amounts through agriculture processes directly linked to the production of food and feed. It forms part of the reactive nitrogen fraction and, despite the fact of enormous benefits from its use as nitrogen fertilizer to sustain a growing population, serious side effects have been described, which have in general a negative impact on ecosystem health and biodiversity. Countries across Europe have country-level specific pollution control systems to try and cut emissions and internationally this is coordinated by the International Nitrogen Initiative (INI, <http://www.initrogen.org>).

It is clear that the measurement of ammonia must be driven by policy requirement or research need, and the range of techniques available from passive sampler to traceable transfer-standard spectroscopy need to be linked up metrologically, through standards, intercomparisons and good routine quality assurance and control. A good practice guide was written to summarise the outcome of the MetNH₃ work, as applied to practical ambient ammonia measurements. Table 5 summarises the ranges for consideration:

Table 5: Uncertainty ranges for ammonia measurement

Temporal resolution	Uncertainty	Method Documentation
1 day - 1 month	<30%	CEN standard or ISO or EMEP defined
Maximum daily	<10%	CEN standard or ISI publication defined

10 Hz- Hourly	Better than 5% or RESEARCH level	User provided; Research evidence
---------------	----------------------------------	----------------------------------

4 Actual and potential impact

4.1 Dissemination activities

4.1.1 Scientific publications

This project has generated four scientific publications and the list is available in section 6.

4.1.2 Presentations

The project's activities and results have been disseminated, with 37 presentations on targeted scientific events such as EGU 2015/2016/2017, AGU 2015/2016, GAS 2015 (including award for best poster), INI 2016, OPD 2016, FOA 2016 and at the NH₃ workshop at Hildesheim 2015/2016 and at events for a broader audience, e.g. Pittcon 2015, and CIM 2015 and at trade fairs (Control 2015, Sensor and Test 2015). MetNH3 results are continued to be presented after the end of the project, e.g. at GAS 2017 and at the NH₃ workshop at Hildesheim 2017. Organisation of dedicated scientific events

Two MetNH3 workshops on the progress in ammonia metrology and on ammonia measurement methodology, respectively, were organised and attracted a total of 90 participants. The workshops consisted of scientific presentations from partners and stakeholders on all relevant subjects thus offering a valuable platform for the exchange of knowledge.

Moreover, a splinter meeting was organised in the framework of EGU2017 where the results of the spectroscopic measurements of the MetNH3 field intercomparison were communicated to and discussed with researchers, representatives of measurement networks and instrument manufacturers.

4.1.3 Engagement with standardisation and metrological committees

Project partners are closely linked to stakeholders and to end-users by being members or service providers of key national or international environmental monitoring networks and by participating in standardisation activities: CEN/TC 264/WG 11 Ambient air quality - Diffusive samplers for the determination of gases and vapours - Requirements and test methods, other TC 264 Working Groups, ISO/TC 146 Air quality, and ISO/TC 158 Analysis of gases, CCQM Gas Working Group and EURAMET TC METCHEM or by collaborating with National Environmental Institutes. An advisory board consisting of members of research institutes and air monitoring networks as well as of the European Institute for Environment and Sustainability has been set up.

The MetNH3 coordinator was invited to give a presentation on the project during the 34th meeting of the CCQM Gas Analysis Working group GAWG and results were presented during the EURAMET TC-MC, SC Gas Analysis meeting.

Within the course of the project, the results of MetNH3 were presented in the nitrogen cycle meeting of WMO-GAW and to the UNECE Task Force for Measurement and Modelling. The transfer of findings from the metrology research to the end-users from industry and the atmospheric measurement community is the main motivation for the tree "Good Practice Guides" shortly available and will be continued beyond the duration of MetNH3.

4.2 Early impact

Accurate, stable and traceable CRM and validated measurement methods are the bases for achieving comparability and standardisation as well as reducing the uncertainty of measurement results across networks and among various analytical techniques.

The results of the study on the stability of gas mixtures pressurised in cylinders have presented several times to specialist gas producers yet, for commercial mass production, selling gas mixtures in stainless steel cylinders coated with a silica-based material is currently not cost-effective, as costs of stainless steel cylinders are much higher compared to conventional aluminium cylinders. The coating cannot be applied to all aluminium alloys. A successful collaboration between a partner and a speciality gas manufacturer confirmed reduced adsorption on their cylinders treated with a proprietary method.

Furthermore, the new findings on adsorption reduction will support the organisers of the key comparison CCQM K-117, which is planned for 2018 in the preparation of the cylinders. Furthermore, the discrepancies observed in a previous key comparison (CCQM K-46) between the applicants of different analytical techniques should be reduced considerably due to hopefully reduced adsorption losses. This will allow the participating NMIs to make claims for CMCs at lower levels of uncertainty.

One publication on the current state of NH₃ measurements in ambient air has been published.

The impact of this project was ensured by the extensive network of the consortium members, which also includes the leading SMEs developing analytical instruments for measuring ammonia in ambient air. Collaborations with mainly industrial participants have been finalised, of which the collaboration with Picarro Inc. has already led to a peer reviewed publication which was awarded joint runner-up for NPL's Rayleigh Award. In addition to implementing the results of this study, a new data evaluation algorithm, to their NH₃ analysers they are also reducing the adsorption on the instrument surfaces by applying the silica-based coating.

DFM improved and validated software for general least squares fitting including uncertainty propagation of input parameters. PTB used this software to implement a new spectral data evaluation method for a commercial spectrometer, enabling the required uncertainty propagation in compliance with the GUM and the determination of relevant metrological quantities such as uncertainty contributions and covariance. DFM's least squares fitting software and PTB's implementation to the evaluation of spectral data may serve as the basis for further absolute laser-spectrometers, since the implementation is flexible and transferable. Molecular parameters that link the ammonia amount fraction to spectroscopic measurement signals were measured and published by PTB. This data served as input parameters in PTB's data evaluation. The data evaluation was further refined by using data on ammonia absorption line broadening through water, determined in collaboration between NPL and Picarro, Inc. and published by Martin et al., 2016. A mobile humidity and aerosol generator developed by REG(NERC) was used by PTB to characterize cross-interference of the extractive spectrometer to water.

Validated ammonia measurement data of high quality from air monitoring networks are vitally important for identifying changes due to the implementation of environmental policies, for minimising the uncertainties in current emission inventories and for providing independent verifications of atmospheric model predictions.

The impact of newly produced CRM has enabled a laboratory assessment of currently employed diffusive uptake rates of passive sampler and denuders to be carried out for the first time. These indirect wet chemical methods are the most widely employed measurement instruments because they are low cost and can be deployed over a very wide geographical area. However, up to now, the accuracy of such devices has not been well characterised and there is no established traceability infrastructure to underpin their accuracy. The measurement of traceable diffusive uptake rates with an uncertainty in the range of 5 %-11 % has delivered improved agreement between different designs of samplers in field collocation studies. It has also provided the tools to determine the relative expanded uncertainty for ammonia measurements at a number of key concentrations. An example is the annual critical load of 3 µg m⁻³ where the uncertainty is of the order of ± 20 %. These findings will be a key input for documentary standards of CEN TC264 Air quality WG11 Ambient air quality - Diffusive samplers for the determination of gases and vapours - Requirements and test methods. Moreover, dissemination activities are promoting the findings in the EEA European Measurement and Monitoring Programme EMEP.

The second MetNH₃ field intercomparison brought together 15 participants, including SMEs, regional and national institutions and MetNH₃ project partners and 10 different measurement technologies were applied. Several techniques were replicated but with different field set-ups, which has allowed an assessment of the effect of set-up on ammonia measurement to be undertaken. It is expected that a peer-review publication will be submitted and the observations from the exercise incorporated into the good practice guide for measurement of ambient ammonia concentrations in the field and application to policy evidence.

The results of the laboratory and the field studies are expected to be published in peer reviewed journals.

Additional value is added to this study as it is the first NH₃ field intercomparison which applied SI-traceable, on-site calibration facilities for the calibrations of the different analysers. These facilities were developed in the framework of MetNH₃: The first is a dynamic dilution facility applying thermal mass for controllers coupled to reference gas mixtures in cylinders. The set-up could be used to calibrate instruments requiring high sample gas flow rates. The second device applied was a mobile reference gas generator combining permeation and

dynamic dilution over two steps with thermal mass flow controllers in order to generate reference gas mixtures directly at ambient amount fractions. This instrument is a first of its kind.

A copy of the mobile reference gas generator developed and constructed within MetNH3 has been commissioned by the partner's national air pollution monitoring network to be applied for traceable calibrations of analysers for various reactive compounds (e.g. NH₃ and NO₂).

4.3 *Potential impact*

Establishing traceable, absolute laser-spectrometer as optical transfer standards for ammonia in air has the prospect of supplementing (and to a certain degree perhaps replacing) calibrations using reference gas mixtures. On a long-term perspective, OTS instruments may be used to calibrate ammonia analyser in a side-by-side comparison, with ambient air as the test gas. This would reduce down-times and would save time and money for air monitoring networks. It is conceivable that instrument manufacturers more actively target the development of absolute spectrometers (some already advertise their instruments as absolute) due to the findings of the MetNH3 project.

The collaboration between METAS, PTB and VTT led to the construction of traceability chain between several instruments: gas generator by METAS, extractive CRDS spectrometer (OTS) by PTB, sampling free spectrometer (OTS) by VTT, and another commercial CRDS spectrometer which was transported between the two laboratories. This comparison yielded valuable information on behaviour, accuracy and applicability of developed methods and standards in different practical situations. All these can be used as reference devices in future studies.

From the CATFAC chamber, passive and active field intercomparisons and the inlet testing, simple guidelines for documenting quality control and assurance of ammonia measurements have begun and in the future years CEH and MetNH₃ partners can work to enable the incorporation of knowledge developed in MetNH3 for studies ranging from site impact, ecosystem monitoring and long term air quality stations. Within the planning for WMO-GAW, EMEP and other global networks, the standards for good quality field-applicable should become routine. Given the spatiotemporal variability of ammonia in the landscapes of Europe traceability will enable confidence in the detecting change. Ammonia remains one of the few anthropogenic pollutants predicted to increase in the twenty first century.

The following points are planned to be implemented within the coming years:

- a. CEN Ammonia passive sampler review and CEN protocol finalised
- b. UK and global quality assurance in line with CEN standard for passive samplers
- c. Regular use of calibration systems developed in MetNH3 (ReGaS1 and OTS) in long term monitoring

The work published by Martin et al. in on the improved spectroscopic fitting of water in ammonia measurements has improved the awareness in the spectroscopy community of the co-adsorption of ammonia and water and thus the potential for biases in atmospheric measurements when water concentrations of the measured air are not taken into account. Several extractive optical instrument manufacturers, particularly participants of the MetNH3 field intercomparison were able to assess the quality of their instrument in the course of this study.

The global air quality community is aware of the important role of NH₃ in atmospheric chemistry and the pressure to reduce emissions has been increased by the latest revision of the European Directive 2016/2284/EU. For MetNH3 project partners it has been a task to raise awareness for the importance of SI-traceability as the key to comparability of measurements obtained at different places and at different times. Knowledge has been transferred via publications, presentations on various occasions and during meetings with stakeholders.

The most commonly applied techniques for monitoring the development of NH₃ emissions are indirect measurements via dry and wet chemical methods. The work of MetNH3 project partners offers revised diffusive uptake rates for a variety of applied passive samplers. Optical instruments for direct and high-resolution measurements require calibration with reference gas mixtures or with an OTS. SI-traceable CRM with low uncertainties are being made available to end-users for applications in laboratories and in the field.

5 Website address and contact details

<http://metnh3.eu>

For further information on the project contact Mr. [Bernhard Niederhauser](#), METAS.

6 List of publications

1. Andrea Pogány et al.: A metrological approach to improve accuracy and reliability of ammonia measurements in ambient air. *Meas. Sci. Technol.* (2016) **27** 115012
2. Nicholas A. Martin et al.: The application of a cavity ring-down spectrometer to measurements of ambient ammonia using traceable primary standard gas mixtures. *Appl. Phys. B* (2016) 122: 219
3. A. Pogány et al.: Metrology for ammonia in ambient air – concept and first results of the EMRP project MetNH3. *Proceedings of the 17 International Congress of Metrology*, 07003 (2015)
4. A. Pogány et al.: High-Accuracy Ammonia Line Intensity Measurements at 1.5 μm . *Imaging and Applied Optics 2016*, paper JT3A.15

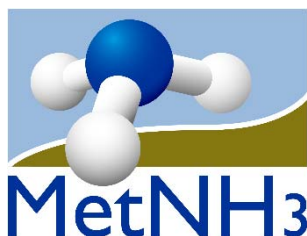

JRP-Partners

METAS (Federal Institute of Metrology), Switzerland. [Bernhard Niederhauser](#)

BAM (Federal Institute for Materials Research and Testing), Germany. [Dr. Carlo Tiebe](#)

DFM (National Metrology Institute), Denmark. [Dr. David Balslev-Harder](#)

VTT MIKES Metrology (National Metrology Institute), Finland. [Dr. Timo Rajamäki](#)

NPL (National Metrology Institute), United Kingdom. [Dr. Nicholas Martin](#)

PTB (National Metrology Institute), Germany. [Dr. Niils Lüttschwager](#)

UBA (Federal Environment Agency), Germany. [Dr. Klaus Wirtz](#)

VSL (National Metrology Institute), The Netherlands. [Janneke van Wijk](#)

Researcher Excellence Grants

NERC CEH Centre for Ecology and Hydrology, United Kingdom. [Dr. Christine Braban](#)

UH University of Helsinki, Finland. [Dr. Olavi Vaittinen](#)

