

Northumbria Research Link

Citation: Bortot, Eliana, Springhetti, Roberta, deBotton, Gal and Gei, Massimiliano (2015) Optimization of Load-driven Soft Dielectric Elastomer Generators. *Procedia IUTAM*, 12. pp. 42-51. ISSN 2210-9838

Published by: Elsevier

URL: <http://dx.doi.org/10.1016/j.piutam.2014.12.006>
<<http://dx.doi.org/10.1016/j.piutam.2014.12.006>>

This version was downloaded from Northumbria Research Link:
<http://nrl.northumbria.ac.uk/38897/>

Northumbria University has developed Northumbria Research Link (NRL) to enable users to access the University's research output. Copyright © and moral rights for items on NRL are retained by the individual author(s) and/or other copyright owners. Single copies of full items can be reproduced, displayed or performed, and given to third parties in any format or medium for personal research or study, educational, or not-for-profit purposes without prior permission or charge, provided the authors, title and full bibliographic details are given, as well as a hyperlink and/or URL to the original metadata page. The content must not be changed in any way. Full items must not be sold commercially in any format or medium without formal permission of the copyright holder. The full policy is available online: <http://nrl.northumbria.ac.uk/policies.html>

This document may differ from the final, published version of the research and has been made available online in accordance with publisher policies. To read and/or cite from the published version of the research, please visit the publisher's website (a subscription may be required.)

www.northumbria.ac.uk/nrl





IUTAM Symposium on Mechanics of Soft Active Materials

Optimization of load-driven soft dielectric elastomer generators

Eliana Bortot^a, Roberta Springhetti^a, Gal deBotton^b, Massimiliano Gei^{a,*}

^aDepartment of Civil, Environmental and Mechanical Engineering, University of Trento, Via Mesiano 77, I-38123 Trento, Italy;

^bDepartment of Mechanical Engineering, Ben-Gurion University, PO Box 653, Beer-Sheva 8410501, Israel.

Abstract

The performance of energy harvesting generators based on dielectric elastomers is investigated in this contribution. The amount of energy extracted by a four-step load-driven cycle is constrained by structural instabilities due to the loss of tension, the electric breakdown and the ultimate stretch ratio. To identify the optimal cycle complying with these limits, we formulate a constraint optimization problem proving the dependency of the generator performance on the ultimate stretch ratio and, moreover, a universal limit on the dielectric strength beyond which the optimal cycle is independent of this parameter. Thus, we reveal that there is an upper bound on the amount of harvested energy that depends only on the ultimate stretch ratio.

© 2014 The Authors. Published by Elsevier B.V. This is an open access article under the CC BY-NC-ND license (<http://creativecommons.org/licenses/by-nc-nd/3.0/>).

Peer-review under responsibility of Konstantin Volokh and Mahmood Jabareen.

Keywords: Energy harvesting; electro-active polymers; smart materials; optimization; electroelasticity

1. Introduction

A particularly promising technology to harvest energy from renewable resources such as sea waves, wind, human gait and others is that based on soft dielectric elastomers (DEs)^{1,2,3,4,5,6,7}. A dielectric elastomer generator (DEG) is a highly deformable parallel-plate capacitor made out of a soft DE film coated with two compliant electrodes on its opposite faces. The capacitance depends on the deformation undergone by the film (through both the faces area and the thickness), hence it changes during a load and release cycle resulting from the interaction of the device with its environment. This variability can be exploited to extract electric energy by initially stretching, then charging the capacitor and subsequently releasing the stretch and collecting the charge at a higher electric potential.

A few recent papers are dedicated to the analysis of the performance of DEGs and the identification of the more profitable electromechanical loading strategies during which the energy gain is maximized. The contour of the region of admissible states, which is dictated by typical failure modes of DEs was examined in⁸ within the framework of finite electroelasticity. A method to measure the produced energy and the efficiency of a balloon-like generator was developed in⁹. In¹⁰ various choices of electromechanical cycles for energy harvesting are presented. An equibiaxial loading configuration of the device is assumed in¹¹, who considered viscous effects too, while a polymeric oscillating water column was proposed in^{5,6}. The possible benefits from embedding ceramic particles in a soft matrix on the amount of generated energy was considered in¹².

* Corresponding author. Tel.: +39 0461 282523; fax: +39 0461 282599.
E-mail address: massimiliano.gei@unitn.it (Massimiliano Gei).

In the present work we focus on dielectric elastomer generators subjected to a four-stroke electromechanical cycle, in which an external oscillating force powers the stretch and contraction cycle. It is assumed that the device deforms under a plane-strain condition that simulates the effect of transverse constraint due to a supporting frame. Taking into account the properties of the elastic dielectric and the operating conditions dictated by the external environment, with the aid of a constrained optimization algorithm, our goal is to identify those cycles that produce the maximum energy. This, in turn, will shade light on the relative role of the various failure mechanisms and provide guidelines for choosing suitable elastic dielectrics for the DEG. Time-dependent effects such as viscosity and loading frequencies are neglected and the results are determined assuming a conservative behaviour of the elastic dielectric.

The generator may undergo different failure mechanisms which must be avoided to ensure proper functioning and long service life of the device. In the assumed plane-strain conditions the possible limits on the DEG performance are set by the electric breakdown threshold, a state of loss of tension with consequent buckling instability, and mechanical failure represented by the maximal allowable longitudinal stretch. These failure limits identify a contour of an admissible operational domain that can be depicted in the stress-stretch and the electric potential-charge planes. In both representations the area enclosed within this contour is equal to a theoretical upper bound on the maximal energy that may be harvested from the DEG⁸. The shape of the contour leads us in this work to distinguish between two types of optimal cycles depending on whether or not the electric breakdown limit is attained during the cycle.

We conclude the work with numerical analyses of two representative cases depending on the maximal allowable stretch for the cycle: the first corresponds to a relatively stiff dielectric elastomer with a limited range of reversible stretches, whereas the second deals with a ductile elastomer that may be stretched a few times its referential length. For both cases, general dimensionless analyses are carried out first for the two different types of optimal cycles. Eventually, the analysis is specialized to two specific materials, a natural rubber and an acrylic elastomer, and the final results are given in a dimensional form.

2. Electro-elastic modelling of a soft energy harvester

In the course of this section we recall only those results that are pertinent to the subsequent analysis of DEGs. These are based on the comprehensive analyses of dielectric layers subjected to electromechanical loading carried out in^{13,14,15}. Essentially, a DEG is a stretchable capacitor, the basic idea behind its operating principle consists in its ability to change the capacitance with deformation. To clarify this concept, consider a dielectric elastomer occupying domains B_0 and $B \in \mathbb{R}^3$ in the reference and the deformed configurations, respectively. These are schematically illustrated in Fig. 1. Throughout, cartesian coordinate systems are adopted in order to identify the positions of a point \mathbf{x}_0 and $\mathbf{x} = \chi(\mathbf{x}_0)$ in the two configurations, respectively. Here, χ is the mapping from the reference to the deformed configurations and $\mathbf{F} = \partial\chi/\partial\mathbf{x}_0$ is the deformation gradient.

We consider an ideal dielectric film which is homogeneous, isotropic, hyperelastic, incompressible ($J \equiv \det \mathbf{F} = 1$), lossless and with no electrostrictive behaviour^{16,17,18,19}. The film is stretched from the reference to the deformed configuration by a combination of (i) a mechanical force per unit undeformed length s along direction 1 induced by the environment which is the primary source for the energy invested into the system, and (ii) an electric field generated by an electric potential ϕ between the two stretchable electrodes applied on the opposite surfaces of the film at $x_2 = 0$ and h .

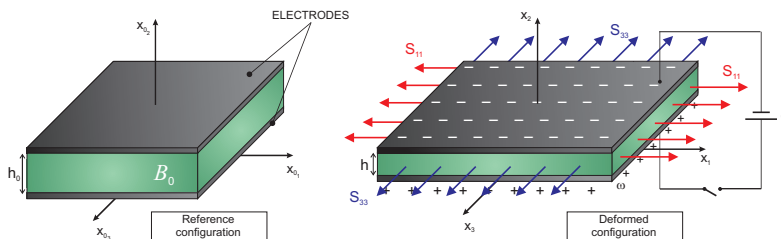

Fig. 1. Reference and deformed configurations of a soft dielectric elastomer generator deforming in the $\{x_1, x_2\}$ -plane under plane-strain conditions.

Neglecting fringing effects and assuming isotropy, the electromechanical deformation undergone by the film is homogeneous and can be represented by the deformation gradient $\mathbf{F} = \text{diag}(\lambda, \lambda^{-1}, 1)$, where λ is the principal stretch ratio along x_1 . Outside the capacitor the electric fields vanish, and the uniform electric field induced by the applied electric potential inside the film is $\mathbf{E} = [0, E, 0]^T$. Recall that \mathbf{E} is conservative admitting the representation $\mathbf{E} = -\text{grad}\varphi(\mathbf{x})$, with φ being the electrostatic potential field such that $\phi = \varphi|_{x_2=0} - \varphi|_{x_2=h}$, i.e. $E = \phi/h$. In view of the homogeneous fields developing in the film, the applied force s can be easily related to the nominal total stress \mathbf{S} , which is divergence free when body forces are null. Thus, along the prescribed loading path $\mathbf{S} = \text{diag}(S_{11}, S_{22}, S_{33})$, where $S_{11} = s/h_0$, $S_{22} = 0$ and S_{33} is the reaction to the kinematic plane-strain constraint. The energy conjugate to the electric field \mathbf{E} is the electric displacement field \mathbf{D} , which is divergence free in the absence of free charges in the material. Within the context of this work it is advantageous to represent the electric fields in terms of their referential counterparts $\mathbf{E}_0 = \mathbf{F}^T \mathbf{E} = [0, E_0, 0]^T$, with $E_0 = E/\lambda$, and $\mathbf{D}_0 = \mathbf{J}\mathbf{F}^{-1}\mathbf{D}$. In¹⁶ it is shown that the former is conservative and the latter is divergence free.

The electroactive hyperelastic incompressible material is assumed to be governed by an isotropic augmented energy-density function $W(\lambda_1, \lambda_2, \lambda_3, E_0)$, where λ_1, λ_2 and λ_3 are the principal stretch ratios satisfying the incompressibility constraint $J = \lambda_1\lambda_2\lambda_3 = 1$. The constitutive equations thus read

$$S_{ii} = \frac{\partial W}{\partial \lambda_i} - p \frac{1}{\lambda_i}, \quad D_0 = -\frac{\partial W}{\partial E_0}, \quad (1)$$

where p is the unknown hydrostatic pressure, D_0 is the sole non-vanishing component of \mathbf{D}_0 , namely $\mathbf{D}_0 = [0, D_0, 0]^T$, and no sum is implied on the components S_{ii} .

To illustrate the main features of the load-driven DEG, we adopt the simplest form of energy-density W , i.e. the one derived from neo-Hookean elasticity, namely

$$W = \frac{\mu}{2}(\lambda_1^2 + \lambda_2^2 + \lambda_3^2 - 3) - \frac{\epsilon}{2} \left(\frac{E_0}{\lambda_2} \right)^2. \quad (2)$$

Here μ is the shear modulus of the material and $\epsilon = \epsilon_r \epsilon_0$ its permittivity being ϵ_r the relative dielectric constant and $\epsilon_0 = 8.854 \text{ pF/m}$ the permittivity of vacuum. In the present case $\lambda_1 = \lambda, \lambda_2 = \lambda^{-1}, \lambda_3 = 1$ and Eq. (2) implies that $D_0 = \epsilon \lambda^2 \phi / h_0$. Accordingly, the charge on the electrodes per unit of their undeformed area ω_0 can be related to the stretch ratio λ and the electric potential ϕ because the boundary condition on both sides corresponds to $\omega_0 = D_0$.

In the sequel we find it advantageous to rephrase the equations in terms of the *dimensionless* variables

$$\bar{S}_{11} = \frac{S_{11}}{\mu}, \quad \bar{S}_{33} = \frac{S_{33}}{\mu}, \quad \bar{\phi} = \frac{\phi}{h_0} \sqrt{\frac{\epsilon}{\mu}}, \quad \bar{\omega}_0 = \frac{\omega_0}{\sqrt{\epsilon\mu}}. \quad (3)$$

Next, with the aid of Eq. (2) the components of the applied stress can be related to λ and ϕ . Accordingly, during the harvesting cycle the relations between the applied stress, the applied electric potential, the resulting stretch ratio and the charge accumulated on the electrodes are:

$$\bar{S}_{11} = \lambda - \frac{1}{\lambda^3} - \bar{\phi}^2 \lambda, \quad \bar{S}_{33} = 1 - \frac{1}{\lambda^2} - \bar{\phi}^2 \lambda^2, \quad \bar{\phi} = \frac{\bar{\omega}_0}{\lambda^2}. \quad (4)$$

3. The load-driven harvesting cycle and the area of admissible configurations

A few possible harvesting strategies, which are primarily distinguished according to the control parameters chosen for the four-stroke cycles, are discussed in¹⁰. Here we focus on the cycle illustrated in Fig. 2: along two of the strokes the longitudinal stress S_{11} due to the external load is fixed, whereas along the other two strokes the device is electrically isolated and the charge ω_0 in the electrodes is held fixed. The order of these strokes and their role in the harvesting cycle are:

- a mechanical loading stroke A–B: the work produced by the external oscillating force during its rise from minimal to maximal values is stored in the elastically stretching generator. In terms of the dimensionless

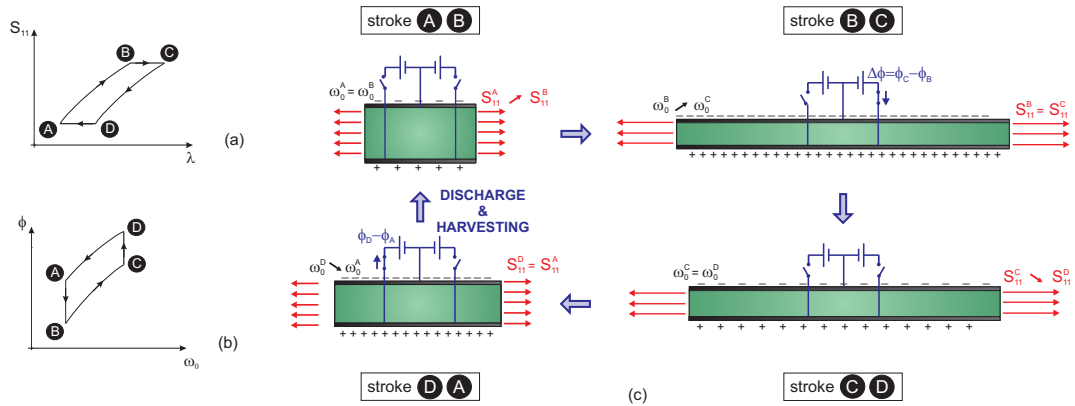

Fig. 2. The harvesting cycle plotted on the mechanical plane (a) and the electrical plane (b), characterization of the four strokes with a service battery at the right and a storage battery at the left (c); all the plots in the descriptive sequence in (c) are referred to the initial state of the single stroke.

variables, \bar{S}_{11} increases from its minimal value at A to its maximal value at B, while the charge on the electrodes is fixed ($\bar{\omega}_0^A = \bar{\omega}_0^B$). Due to the stretching of the film the capacitance of the DEG increases and the electric potential drops;

- an electrical charging stroke B–C: the electrodes are charged by means of an external service battery such that the electric potential between them is $\Delta\bar{\phi} = \bar{\phi}_C - \bar{\phi}_B > 0$. Along this step the stress is held constant ($\bar{S}_{11}^B = \bar{S}_{11}^C$). Thanks to the attraction between the two charged electrodes the film further shrinks in the x_2 -direction and elongates in the x_1 -direction. When this stroke terminates the film attains the largest stretch ratio during the cycle (λ_C);
- a mechanical unloading stroke C–D: during the decline of the external force from its maximal to minimal values the film shrinks while the charge in the isolated electrodes is fixed ($\bar{\omega}_0^C = \bar{\omega}_0^D$). The thickening of the shrinking film results in an increase of the electric potential to $\bar{\phi}_D$, which is the largest value of $\bar{\phi}$ along the cycle;
- an electrical energy-harvesting stroke D–A: the charge deposited in stroke B–C is redeemed at a higher electric potential with an appropriate electrical circuit. This energy-harvesting stroke is executed with a fixed load ($\bar{S}_{11}^D = \bar{S}_{11}^A$), nonetheless, due to the decrease in the electric potential between the electrodes and hence the associate decrease in the attracting force between them, the film further shrinks.

The cycle can be presented on the thermodynamical planes illustrated in Figs. 2(a) and (b), with Fig. 2(a) corresponding to the mechanical S_{11} – λ plane and Fig. 2(b) to the electrical ϕ – ω_0 plane. In passing, we note that in practice strokes B–C and D–A are substantially shorter than the mechanical loading and unloading strokes. Thus, the applied external force should be considered as a continuously oscillating force, so that, when it attains its maximal and minimal values, appropriate electrical circuits are temporarily connected to the electrodes.

The four-stroke harvesting cycle described above is characterized by the four equalities presented in Fig. 2(c). These induce the following relations among the corresponding eight dimensionless independent variables:

$$\begin{aligned} \bar{\omega}_0^A = \bar{\omega}_0^B &\Rightarrow \bar{\phi}_A \lambda_A^2 = \bar{\phi}_B \lambda_B^2, & \bar{S}_{11}^B = \bar{S}_{11}^C &\Rightarrow \lambda_B - \frac{1}{\lambda_B^3} - \bar{\phi}_B^2 \lambda_B = \lambda_C - \frac{1}{\lambda_C^3} - \bar{\phi}_C^2 \lambda_C, \\ \bar{\omega}_0^C = \bar{\omega}_0^D &\Rightarrow \bar{\phi}_C \lambda_C^2 = \bar{\phi}_D \lambda_D^2, & \bar{S}_{11}^D = \bar{S}_{11}^A &\Rightarrow \lambda_D - \frac{1}{\lambda_D^3} - \bar{\phi}_D^2 \lambda_D = \lambda_A - \frac{1}{\lambda_A^3} - \bar{\phi}_A^2 \lambda_A. \end{aligned} \quad (5)$$

In order to ensure a proper operational condition of the device, all feasible cycles must lie inside the region of admissible states for the generator. The contour line enveloping this region is defined by the following possible failure modes of the DEG:

- electric breakdown (EB): this failure occurs when the electric field E reaches the dielectric strength of the material E_{eb} . In dimensionless form the dielectric strength is $\bar{E}_{eb} = E_{eb} \sqrt{\epsilon/\mu}$. The corresponding portions of

the failure envelopes surrounding the region of admissible states in the mechanical and the electric planes are prescribed in terms of the curves:

$$\bar{S}_{11} = \lambda - \frac{1}{\lambda^3} - \frac{\bar{E}_{eb}^2}{\lambda}, \quad \bar{\phi} = \frac{\bar{E}_{eb}^2}{\bar{\omega}_0}; \quad (6)$$

- ultimate stretch (λ_U): this failure takes place when the magnitude of the stretch attains a critical value λ_U at which mechanical failure initiates. The curves that correspond to this failure mode in the mechanical and the electric planes are, respectively:

$$\lambda = \lambda_U, \quad \bar{\phi} = \frac{\bar{\omega}_0}{\lambda_U^2}; \quad (7)$$

- loss of tension ($S_{33}=0$): to avoid failure due to buckling¹⁸ of wrinkling in compression²⁰ it is required that the two in-plane stresses be positive. This failure mode is associated with the geometrical configuration of the device and is related to the small thickness of the film. A comparison between eqs. (4)₁ and (4)₂ for the two stresses reveals that the inequality $S_{33} \geq 0$ is more restrictive than $S_{11} \geq 0$. Therefore, by manipulating these expressions it is found that the portions of the failure envelopes corresponding to loss of tension along the x_3 -direction in the two pertinent planes are characterized by the curves

$$\bar{S}_{11} = \lambda - \frac{1}{\lambda}, \quad \bar{\phi} = \frac{\bar{\omega}_0}{1 + \bar{\omega}_0^2}. \quad (8)$$

We finally add a fourth formal condition ($E=0$), which is not related to a failure of the system, requiring that the direction of the electric field is not reversed during the cycle, i.e. $E \geq 0$.

4. Optimization of the harvesting cycle

According to the four-stroke cycle described in Section 3, the energy-density generated per unit shear modulus is

$$H_g = \frac{\tilde{H}_g}{\mu V_0} = \int_B^C \bar{\phi} d\bar{\omega}_0 + \int_D^A \bar{\phi} d\bar{\omega}_0. \quad (9)$$

The sum of the two integrals at the right-hand-side of Eq. (9) is equal to the area bounded within the cycle in the electrical plane in its dimensionless form (see Fig. 3). For later reference we recall that, since H_g is an energy extracted from the system, its sign is negative.

Evaluating the integrals and expressing the constant nominal stresses \bar{S}_{11}^B and \bar{S}_{11}^A in terms of the relevant stretches and of the dimensionless nominal electric potentials via Eq. (4)₁, the explicit expression for the dimensionless harvested energy turns to

$$H_g = \frac{1}{2}(\lambda_A - \lambda_D) \left[\lambda_D (3\bar{\phi}_D^2 - 1) + 2\lambda_A + 3\lambda_D^{-3} \right] + \frac{1}{2}(\lambda_C - \lambda_B) \left[\lambda_B (3\bar{\phi}_B^2 - 1) + 2\lambda_C + 3\lambda_B^{-3} \right]. \quad (10)$$

Note that the expression for H_g involves only the squares of the variables $\bar{\phi}_B$ and $\bar{\phi}_D$. Therefore it is convenient to derive $\bar{\phi}_B^2$ and $\bar{\phi}_D^2$ from conditions (5) as functions of the stretches λ_A , λ_B , λ_C and λ_D and substitute them in (10). This will lead to an expression for H_g in terms of the four characteristic stretches. Similar developments can be followed for the constraints defining the failure envelope.

In order to determine the optimal cycle through which the maximum energy can be harvested while keeping it within the region of admissible states, we formulate the following constrained optimization problem:

$$\text{find } \min_{\Lambda} H_g[\lambda_A, \lambda_B, \lambda_C, \lambda_D],$$

with $\Lambda = [\lambda_A, \lambda_B, \lambda_C, \lambda_D]^T$ and the minimum is sought since $H_g \leq 0$. The optimization is to be evaluated under the following constraints:

– on the stretches

$$\lambda_C = \lambda_U, \quad 1 \leq \lambda_A \leq \lambda_U, \quad 1 \leq \lambda_B \leq \lambda_U, \quad 1 \leq \lambda_D \leq \lambda_U. \quad (11)$$

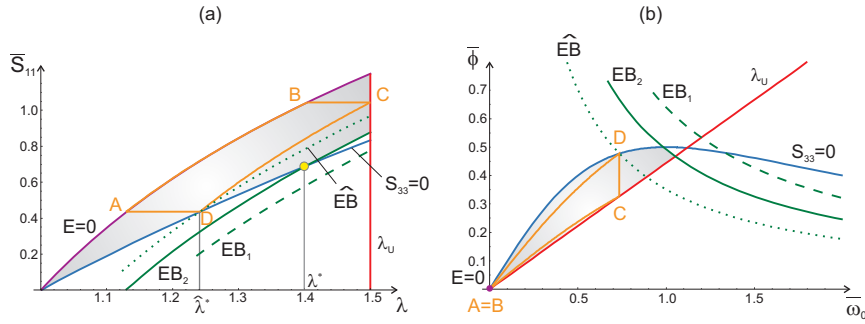

Fig. 3. The optimal cycle (ABCD, in light gray - orange online) for a DE with $\lambda_U = 1.5$ and $\bar{E}_{eb} \geq 0.5922$ plotted on the mechanical plane (a) and the electrical plane (b). Regions of admissible states are painted in grey. The dashed and the continuous curves EB_1 and EB_2 correspond to $\bar{E}_{eb} = 0.8$ (Case 1) and $\bar{E}_{eb} = 0.7$ (Case 2a), respectively. The dotted curve \hat{EB} corresponds to the transition between Cases 2a and 2b, at which $\hat{E}_{eb} = 0.5922$.

The constraint $(11)_1$ enabled us to substitute λ_U for λ_C reducing the set of optimization variables Λ to $\Lambda_R = [\lambda_A, \lambda_B, \lambda_D]^T$; – on the D state

$$S_{33}^D[\lambda_A, \lambda_B, \lambda_D] \geq 0, \quad \bar{E}_D[\lambda_A, \lambda_B, \lambda_D] \leq \bar{E}_{eb}^2. \quad (12)$$

These constraints require the compatibility of the D state with the failure modes due to loss of tension and electric breakdown. More details can be found in²¹.

5. Numerical results

Results of the optimization procedure are illustrated hereafter for two choices of ultimate stretch ratios that are typical for commercial DEs. However, before we proceed with the numerical results, it is useful to distinguish between two types of failure envelopes.

5.1. Classification of possible failure envelopes

A comparison between expressions $(6)_1$ and $(8)_1$ for the stress according to the failure modes (EB) and $(S_{33}=0)$ reveals the possible existence of an intersection point at which simultaneous failures may take place. This is possible only if $\bar{E}_{eb} \leq 1$, and the combined failure occurs at stretch ratio $\lambda^* \equiv (1 - \bar{E}_{eb}^2)^{-1/2}$ (see Fig. 3). If $\bar{E}_{eb} > 1$ these two parts of the failure envelope do not intersect and the limit (EB) is not attainable by the DEG. Because the failure modes (EB) and $(S_{33}=0)$ may induce an independent limit on the stretch ratio of the film, we are led to the following distinction between two possible cases:

- Case 1: if $\lambda_U \leq \lambda^*$ the optimal cycle lies in the envelope dictated by $(S_{33}=0)$, (λ_U) and $(E=0)$, whereas the (EB) failure is unattainable;
- Case 2: if $\lambda_U > \lambda^*$ the failure mode (EB) must be accounted in order to enclose the region of admissible states.

5.2. Low ultimate stretch ratio

We consider first an elastic dielectric with a relatively small range of recoverable strains, $\lambda_U = 1.5$. For this relatively small stretch limit the failure curves $(S_{33}=0)$ and (EB) do not intersect along the contour of the admissible domain as long as $\bar{E}_{eb} \geq 0.7454$. This corresponds to Case 1 where (EB) is not attainable. In Fig. 3 the curve EB_1 that corresponds to $\bar{E}_{eb} = 0.8$ demonstrates this case. Smaller values of \bar{E}_{eb} correspond to Case 2, for which we encounter the following two occurrences:

- Case 2a: in the range $\hat{E}_{eb} < \bar{E}_{eb} < 0.7454$ the optimal cycle is once again the one depicted in Fig. 3, where $\hat{E}_{eb} = 0.5922$. This sub-case is illustrated with the aid of the curve EB_2 that corresponds to $\bar{E}_{eb} = 0.7$. Thus, in a manner similar to the one observed for Case 1, the optimal cycle at point D is not limited by the dielectric strength of the material.

– Case 2b: whenever $\bar{E}_{eb} \leq \hat{E}_{eb}$, the harvesting stroke of the optimal cycle starts at the point where the failure mechanisms ($S_{33}=0$) and (EB) are simultaneously activated, with $\lambda_D = \lambda^*$.

Note that the transition between these two sub-cases at \hat{E}_{eb} entails the coincidence of two points. The first is the intersection point of the two boundaries of the failure envelope ($S_{33}=0$) and (EB), at which $\lambda = \lambda^*(\bar{E}_{eb})$. The second point corresponds to point D of the cycle in the limit $\bar{E}_{eb} = \hat{E}_{eb}$, where \hat{E}_{eb} is the minimal value of the dielectric strength above which the failure curve (EB) is not attainable. This transition is demonstrated in Fig. 3 (for $\lambda_U = 1.5$), where the dotted line represents the failure curve ($\hat{E}B$) for $\hat{E}_{eb} = 0.5922$. The stretch ratio at this point is $\hat{\lambda}^* = \lambda^*(\hat{E}_{eb}) = 1.2410$.

Table 1. Typical results for optimal cycles for DEs with $\lambda_U = 1.5$ and different values of \bar{E}_{eb} .

\bar{E}_{eb}	λ^*	λ_D	$ H_g $	$\Delta\bar{\phi}$	Failure at D
> 0.7454	unessential	1.2410	0.0639	0.3266	($S_{33}=0$)
0.6	1.25	1.2410	0.0639	0.3266	($S_{33}=0$)
$\hat{E}_{eb} = 0.5922$	1.2410	1.2410	0.0639	0.3266	($S_{33}=0$) & (EB)
0.4	1.0911	1.0911	0.0400	0.1940	($S_{33}=0$) & (EB)

Characteristic results for the optimal cycle determined for moderately stretchable DEs are summarized in Table 1 for a few values of the dielectric strength. Together with the amount of energy attained during the optimal cycle $|H_g|$, we also list the stretch ratio λ^* at the intersection between the two failure curves (EB) and ($S_{33}=0$), the stretch ratio λ_D , the dimensionless activation electric potential $\Delta\bar{\phi}$ which is the potential supplied to the DEG during the electrical charging stroke B–C, and the anticipated failure mode at point D. We note that for values of $\bar{E}_{eb} > \hat{E}_{eb}$ the maximal amount of harvested energy is fixed, while for lower values of \bar{E}_{eb} the amount of extractable energy rapidly decreases.

5.3. High ultimate stretch ratio

In a manner similar to the one discussed for the moderately stretchable elastomers, Case 2 is further subdivided into Case 2a for $\hat{E}_{eb} < \bar{E}_{eb} < 0.9428$ and Case 2b for smaller values of \bar{E}_{eb} . The transition value of the dielectric strength for the stretchable DEs is $\hat{E}_{eb} = 0.8263$. In agreement with our previous discussion, as long as $\bar{E}_{eb} > \hat{E}_{eb}$ the optimal cycle is unaffected by the failure curve (EB), while if the dielectric strength of the material is smaller than the transition value, the optimal cycle does depend on the failure curve (EB).

We observe that a two fold decrease in the dimensionless dielectric strength ($0.83 \rightarrow 0.4$) results in almost a four fold decrease in the dimensionless harvested energy ($0.27 \rightarrow 0.073$), cf. Table 2. Yet, we stress again that for $\bar{E}_{eb} > \hat{E}_{eb}$, the amount of energy harvested is fixed.

5.4. Optimal material parameters

The non-dimensional analyses carried out in subsections 5.2 and 5.3 demonstrate that there is a fine balance between the dielectric strength and the ultimate stretch ratio of the DE. Thus, on one hand at low values of E_{eb} the amount of extractable energy is low, and on the other hand larger values of E_{eb} may be unattainable depending on the ultimate stretch ratio. In Fig. 4 we highlight this result with the aid of a universal curve which is plotted on the λ_U – \bar{E}_{eb} plane. The continuous curve shows the variation of \hat{E}_{eb} as a function of λ_U . The optimal cycle of a DEG based on a dielectric, whose pair of electromechanical properties $\{\lambda_U, \bar{E}_{eb}\}$ is located beneath this curve, will depend on \bar{E}_{eb} (Case 2b) and the amount of energy that may be harvested from this DEG is rather small, as discussed before. If the couple of the material characteristics $\{\lambda_U, \bar{E}_{eb}\}$ is located above this curve (Cases 1 and 2a), the optimal cycle and hence the amount of harvested energy does not depend on \bar{E}_{eb} and the DE full potentiality is not exploited. Thus, in order to extract the maximum from the DEG it is recommended that its couple of electromechanical properties $\{\lambda_U, \bar{E}_{eb}\}$ be as close as possible to the universal curve shown in Fig. 4.

Table 2. Typical results for optimal cycles for DEs with $\lambda_U = 3$ and different values of \bar{E}_{eb} .

\bar{E}_{eb}	λ^*	λ_D	$ H_g $	$\Delta\bar{\phi}$	Failure at D
> 0.9428	unessential	1.7756	0.2724	0.1630	$(S_{33}=0)$
$\hat{E}_{eb} = 0.8263$	1.7756	1.7756	0.2724	0.1630	$(S_{33}=0)$ & (EB)
0.6	1.25	1.25	0.1658	0.0833	$(S_{33}=0)$ & (EB)
0.4	1.0911	1.0911	0.0727	0.0485	$(S_{33}=0)$ & (EB)

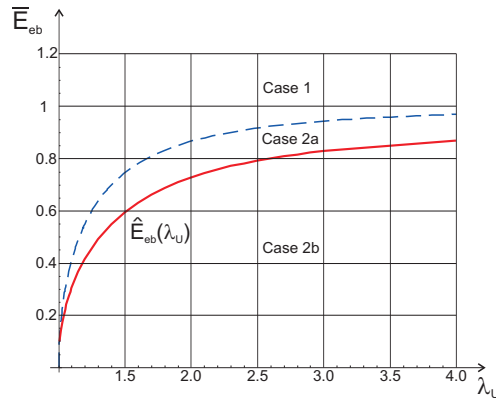

Fig. 4. A universal curve (continuous) that distinguishes between two classes of DE films depicts function $\hat{E}_{eb}(\lambda_U)$; the dotted curve represents the transition between Cases 1 and 2.

5.5. DEGs based on commercially available materials

We apply the analysis previously described to two specific commercially available DEs, the acrylic VHB-4910 and the acrylonitrile butadiene rubber (NBR). The VHB-4910, produced by 3M, is a polyacrylate dielectric elastomer available as a pre-cast 1 mm thick polyacrylate adhesive foam. The acrylonitrile butadiene rubber (NBR) is a synthetic elastomer, produced by co-polymerization of acrylonitrile (ACN) and butadiene rubber (BR). The pertinent electromechanical properties of the two materials listed in Table 3 have been reported in²².

The dielectric strength of these materials, which commonly depends on the applied pre-strain, deserves a particular attention. Thus, we recall that in common EAP applications the films are pre-strained in order to reduce the film thickness and increase the breakdown strength^{23,24}. As an example, the data reported in²³ for VHB-4910 demonstrate that the electric breakdown limit ranges between 20 MV/m in the unstrained state and 218 MV/m in the case of 500% equibiaxial strain. Accordingly, in the sequel two typical values are assumed for the dielectric strength, $E_{eb1} = 20$ MV/m and $E_{eb2} = 100$ MV/m.

Table 3. Physical properties assumed for the elastic dielectrics.

Material	μ [kPa]	ϵ_r	\bar{E}_{eb1}	\bar{E}_{eb2}
VHB-4910 ²²	83.4	4.7	0.4468	2.2338
NBR ²²	1333.4	14	0.1928	0.9642

To enable a comparison between the performance of load-driven DEGs based on these materials, we took the VHB-4910 as a benchmark and determined the maximal stresses ($S_{\max} = S_{11}^B$) attained along the optimal cycles corresponding to all four possible combinations of E_{eb_1} , E_{eb_2} , $\lambda_U = 1.5$ and $\lambda_U = 3$. The four resulting stresses are listed in Table 4. Next, we determined limits on the maximal stretch λ_C of the NBR such that, during the optimal cycles dictated by these stretches and the pair E_{eb_1} and E_{eb_2} , the same maximal stresses will be developed. The resulting stretch ratios for the NBR, together with the harvested energy and the normalized activation potential, are also listed in Table 4. In this table we also list these materials classification (M-C) according to Fig. 4. In agreement with the one order of magnitude larger shear modulus of the NBR, the respective stretches that correspond to similar maximal stresses are an order of magnitude smaller for the NBR.

Table 4. The harvested energy-density μH_g , activation electric potential per referential unit thickness $\Delta\phi/h_0$ and material classification M-C, determined for the optimal cycles according to the dielectric strength limits and the maximal stretch ratios λ_C determined for the maximum stresses S_{\max} .

Material	$E_{eb_1} = 20 \text{ MV/m}$					$E_{eb_2} = 100 \text{ MV/m}$				
	S_{\max} [kPa]	μH_g [kJ/m ³]	$\Delta\phi/h_0$ [kV/mm]	λ_C	M-C	S_{\max} [kPa]	μH_g [kJ/m ³]	$\Delta\phi/h_0$ [kV/mm]	λ_C	M-C
VHB-4910	94.2	3.99	9.9	1.5	(2b)	87.0	5.33	14.62	1.5	(1)
NBR	94.2	0.37	15.4	1.024	(2a)	87.0	0.32	14.81	1.022	(1)
VHB-4910	246.3	7.60	2.5	3	(2b)	240.5	22.72	7.3	3	(1)
NBR	246.3	1.86	18.2	1.059	(2b)	240.5	2.48	23.3	1.064	(1)

At a first sight we deduce from Table 4 that the amounts of energy extractable from the VHB-4910 are an order of magnitude larger than those available for the NBR (when the load or the traction on the DEG are specified). This is due to the extensibility of the former and in spite of the fact that the dielectric constant of the VHB-4910 is substantially smaller than that of the NBR. The critical impact of the stretchability of the film can be further observed when comparing the results determined for the NBR in the second line of Table 4. We note that there is a small difference between the maximal stretch ratios λ_C in favor of the material with the lower dielectric breakdown. Nonetheless, this small difference is responsible for approximately 20% more energy that can be produced with a DEG based on the NBR with smaller E_{eb} .

Another important observation concerns the importance of the classification of the materials. In particular we note the differences in the energies harvested from the VHB-4910. In the first line of Table 4 the energy associated with the VHB-4910 for smaller dielectric strength is comparable with the one extracted from the material whose dielectric strength is 5 times larger. This is because the material with larger dielectric breakdown is associated with Case 1, according to which this larger dielectric strength is not reached during the optimal cycle, so that the potential of the material remains unexpressed. Along the third line of Table 4, where VHB-4910 with larger stretchable domain is considered the situation is somewhat different: the energy extracted from the material with larger E_{eb} is approximately three times the one extracted from the one with smaller E_{eb} . This is because the pair $\{\lambda_U, \bar{E}_{eb}\}$ for the material with larger dielectric breakdown is closer to the universal curve shown in Fig. 4, suggesting that this material is closer to the optimal balance between the ultimate stretch ratio and the dielectric breakdown.

6. Concluding remarks

We investigated the performance of load-driven DE generators made up of a dielectric film coated with compliant electrodes at both sides, undergoing electromechanical cycles in a plane-strain condition. The cycle assumed in our study is composed of the following four strokes: (i) through-thickness thinning and longitudinal stretching driven by an increasing external force at constant electric charge; (ii) application of an electric potential under constant load

allowing charge deposition onto the electrodes; (iii) longitudinal contraction under a decreasing mechanical load and constant electric charge, with the correspondingly electric potential increase; (iv) discharge of the gain charge at a constant load. Overall, a net amount of electrostatic energy is released over a single cycle. In order to identify the best cycle throughout which maximum energy can be harvested, a constraint optimization problem was formulated accounting possible failure modes of the DEG. The failure modes taken into consideration are electric breakdown, mechanical rupture due to an over stretching of the film and the development of instabilities due to loss of tension. These were characterized in terms of appropriate limits on the electrical field, the maximal stretch ratio and the stresses developing in the film.

Acknowledgements

EB acknowledges the support of IUTAM for a travel support grant. MG acknowledges ESNAM (European Scientific Network for Artificial Muscles) COST Action MP1003 for supporting STSM no. 16757.

References

- Anderson I.A., Gisby T.A., McKay T.G., O'Brien B.M., Calius E.P. Multi-functional dielectric elastomer artificial muscles for soft and smart machines. *J. Appl. Phys.* 2012; **112**: 041101.
- Chiba S., Waki M., Kornbluh R., Pelrine R. Current status and future prospects of power generators using dielectric elastomer. *Smart Mater. Struct.* 2011; **20**: 124006.
- Kornbluh R.D., Pelrine R., Prahlad H., Wong-Foy A., McCoy B., Kim S., Eckerle J., Low T. From boots to buoys: promises and challenges of dielectric elastomer energy harvesting. In: Y. Bar Cohen and F. Carpi (Eds). *Electroactive polymer actuators and devices (EAPAD)*, Vol. 7976, Bellingham, WA; 2011.
- McKay T.G., O'Brien B.M., Calius E.P., Anderson I.A. Soft generators using dielectric elastomers. *Appl. Phys. Lett.* 2011; **98**: 142903.
- Vertechy R., Fontana M., Rosati Papini G.P., Bergamasco M. Oscillating-water-column wave-energy-converter based on dielectric elastomer generator. In: Y. Bar Cohen (Ed). *Electroactive polymer actuators and devices (EAPAD)*, Vol. 8687, Bellingham, WA; 2013.
- Vertechy R., Fontana M., Rosati Papini G.P., Forehand D. In-tank tests of a dielectric elastomer generator for wave energy harvesting. In: Y. Bar Cohen (Ed). *Electroactive polymer actuators and devices (EAPAD)*, Vol. 9056, Bellingham, WA; 2014.
- Antoniadis I.A., Venetsanos D.T., Paspaspyridis F.G. DIESYS – dynamically non-linear dielectric elastomer energy generating synergetic structures: perspective and challenges. *Smart Mater. Struct.* 2013; **22**: 104007.
- Koh S.J.A., Zhao X., Suo Z. Maximal energy that can be converted by a dielectric elastomer generator. *Appl. Phys. Lett.* 2009; **94**: 262902.
- Kaltseis R., Keplinger C., Baumgartner R., Kaltenbrunner M., Li T., Mächler P., Schwödauier R., Suo Z., Bauer S. Method for measuring energy generation and efficiency of dielectric elastomer generators. *Appl. Phys. Lett.* 2011; **99**: 162904.
- Lallart M., Cottinet P.J., Guyomar D., Lebrun L. Electrostrictive polymers for mechanical energy harvesting. *Journal of Polymer Science part B: Polymer Physics* 2012; **50**: 523–535.
- Huang J., Shian S., Suo Z., Clarke D.R. Maximizing the Energy Density of Dielectric Elastomer Generators Using Equi-Biaxial Loading. *Adv. Funct. Mat.* 2013; **23**: 5056–5061.
- Bortot E., Springhetti R., Gei M. Enhanced soft dielectric composite generators: the role of ceramic fillers. *J. Eur. Ceram. Soc.* 2014; **34**: 2623–2632.
- deBotton G., Tevet-Derec L., Socolsky E.A. Electroactive heterogeneous polymers: analysis and applications to laminated composites. *Mechanics of Advanced Materials and Structures* 2007; **14**: 13–22.
- Bertoldi K., Gei M. Instability in multilayered soft dielectrics. *J. Mech. Phys. Solids* 2011; **59**: 18–42.
- Shmuel G., Gei M., deBotton G. The Rayleigh-Lamb wave propagation in dielectric elastomer layers subjected to large deformations. *Int. J. Nonlinear Mech.* 2012; **47**: 307–316.
- Dorfmann A., Ogden R.W. Nonlinear electroelasticity. *Acta Mech.* 2005; **174**: 167–183.
- Gei M., Roccabianca S., Bacca M. Controlling band gap in electroactive polymer-based structures. *IEEE-ASME Trans. Mechatron.* 2011; **16**: 102–107.
- Gei M., Colonnelli S., Springhetti R. The role of electrostriction on the stability of dielectric elastomer actuators. *Int. J. Solids Structures* 2014; **51**: 848–860.
- McMeeking R.M., Landis C.M. Electrostatic forces and stored energy for deformable dielectric materials. *J. Appl. Mech.* 2005; **72**: 581–590.
- Puntel E., Deseri L., Fried E. Wrinkling of a stretched thin sheet. *J. Elasticity* 2011; **105**: 137–170.
- Springhetti R., Bortot E., deBotton G., Gei M. Optimal energy-harvesting cycles for load-driven dielectric generators in plane strain. *IMA J. Appl. Math.* 2014; in press.
- Jung K., Lee J., Cho M., Koo J.C., Nam J., Lee Y., Choi H.R. Development of enhanced synthetic elastomer for energy-efficient polymer actuators. *Smart Mater. Struct.* 2007; **16**: S288–S294.
- Kofod G., Kornbluh R., Pelrine R., Sommer-Larsen P. Actuation response of polyacrylate dielectric elastomers. *J. Intell. Mater. Syst. and Struct.* 2003; **14**: 787–793.
- Tröls A., Kogler A., Baumgartner R., Kaltseis R., Keplinger C., Schwödauier R., Graz I., Bauer S. Stretch dependence of the electrical breakdown strength and dielectric constant of dielectric elastomers. *Smart Mater. Struct.* 2013; **22**: 104012.