

Northumbria Research Link

Citation: Buttress, A.J., Hargreaves, G., Ilchev, A., Monti, T., Sklavounou, A., Katrib, J., Martin-Tanchereau, P., Unthank, M.G., Irvine, D.J. and Dodds, C.D. (2019) Design and Optimisation of a Microwave Reactor for Kilo-Scale Polymer Synthesis. Chemical Engineering Science: X. p. 100022. ISSN 2590-1400 (In Press)

Published by: Elsevier

URL: <https://doi.org/10.1016/j.cesx.2019.100022>
<<https://doi.org/10.1016/j.cesx.2019.100022>>

This version was downloaded from Northumbria Research Link:
<http://nrl.northumbria.ac.uk/38847/>

Northumbria University has developed Northumbria Research Link (NRL) to enable users to access the University's research output. Copyright © and moral rights for items on NRL are retained by the individual author(s) and/or other copyright owners. Single copies of full items can be reproduced, displayed or performed, and given to third parties in any format or medium for personal research or study, educational, or not-for-profit purposes without prior permission or charge, provided the authors, title and full bibliographic details are given, as well as a hyperlink and/or URL to the original metadata page. The content must not be changed in any way. Full items must not be sold commercially in any format or medium without formal permission of the copyright holder. The full policy is available online: <http://nrl.northumbria.ac.uk/policies.html>

This document may differ from the final, published version of the research and has been made available online in accordance with publisher policies. To read and/or cite from the published version of the research, please visit the publisher's website (a subscription may be required.)

www.northumbria.ac.uk/nrl



Accepted Manuscript

Design and Optimisation of a Microwave Reactor for Kilo-Scale Polymer Synthesis

A.J. Buttriss, G. Hargreaves, A. Ilchev, T. Monti, A. Sklavounou, J. Katrib, P. Martin-Tanchereau, M.G. Unthank, D.J. Irvine, C.D. Dodds

PII: S2590-1400(19)30029-2
DOI: <https://doi.org/10.1016/j.cesx.2019.100022>
Article Number: 100022
Reference: CESX 100022

To appear in: *Chemical Engineering Science: X*

Received Date: 12 November 2018
Revised Date: 14 March 2019
Accepted Date: 5 April 2019

Please cite this article as: A.J. Buttriss, G. Hargreaves, A. Ilchev, T. Monti, A. Sklavounou, J. Katrib, P. Martin-Tanchereau, M.G. Unthank, D.J. Irvine, C.D. Dodds, Design and Optimisation of a Microwave Reactor for Kilo-Scale Polymer Synthesis, *Chemical Engineering Science: X* (2019), doi: <https://doi.org/10.1016/j.cesx.2019.100022>

This is a PDF file of an unedited manuscript that has been accepted for publication. As a service to our customers we are providing this early version of the manuscript. The manuscript will undergo copyediting, typesetting, and review of the resulting proof before it is published in its final form. Please note that during the production process errors may be discovered which could affect the content, and all legal disclaimers that apply to the journal pertain.



Design and Optimisation of a Microwave Reactor for Kilo-Scale Polymer Synthesis

Buttress, A.J.^a, Hargreaves, G.^a, Ilchev, A.^a, Monti, T.^a, Sklavounou, A.^a, Katrib, J.^a, Martin-Tanchereau, P.^b, Unthank, M.G.^c, Irvine, D.J.^a, Dodds, C.D.^a.

^a Advanced Materials Research Group, Faculty of Engineering, University of Nottingham, NG7 2RD, UK.

^b AkzoNobel, Stonygate Lane, Gateshead, NE10 0JY, UK.

^c Department of Applied Sciences, Northumbria University, Newcastle upon Tyne, NE1 8ST, UK.

Keywords: Microwave; Volumetric Heating; Polyester; Batch Reactor

Abstract

Current industrial production of polymer resins is generally undertaken in large multi-tonne stirred tank reactors. These are characterised by relatively slow heating and cooling cycles, resulting in long vessel cycle times and extended production campaigns. In this work we present a design for a hybrid microwave/oil jacket proof of concept system capable of producing up to 4.1 kg of polymer resin per batch. By exploiting rapid volumetric heating effects of microwave energy at 2.45GHz, we have optimised the synthetic regime, such that a 3.7 kg batch of polyester resin pre-polymer can be made in only 8 hours 20 minutes, with higher molecular weight (M_n 2,100) compared to the conventional process taking 22 hours 15 minutes (M_n 1,200), yielding an increase in synthesis rate of at least 265%. The increase in polymer molecular weight also suggests a higher conversion was achieved over a shorter time scale.

1. Introduction

Polymer materials are ubiquitous to modern life and find use in a huge range of applications including: structural composites; paints and coatings; packaging; as well as fabric fibres. Consequently, global production reached ~322 million tonnes in 2015. [1] However, increasing demand from emerging higher performance markets, coupled with cost pressures on established manufacturers, means that innovative solutions to increase manufacturing efficiency must be found. Industrial production of polymer resins is generally undertaken in large stirred tank reactors heated by oil or steam jackets. [2] These reactors, although well-established, are characterised by long heating/cooling cycles, temperature gradients across the reaction mixture associated with heat transfer from the vessel walls and limitations on mass transfer. As a result, depending on the polymer system, vessel cycle times can vary from six hours to several days. Thus, even relatively small reductions in vessel cycle time can yield significant economic benefits for manufacturers. Process Intensification (PI) is now widely recognised by the chemical industries as one of the most promising approaches to deliver drastic improvements in chemical manufacturing and processing. It is based on the development of new innovative systems and techniques, which deliver faster production rates, with less energy, in smaller equipment with less waste. [3]

Microwave heating technology has the potential to significantly contribute to the goals of process intensification. It is characterised by energy efficient, volumetric heating, from which significantly enhanced heating rates are achievable. It can also be applied with a great degree of control over energy delivery to the system, and in some cases, dependant on specific properties of individual phases/materials, a selective heating effects can be achieved [4, 5]. Furthermore, dipole polarisation by the oscillating electromagnetic field of the microwave

energy has shown to enhance reaction kinetics. Effectively demonstrating localised heating at molecular scales of reactive functional groups [6-8]. Its application in small-scale chemical synthesis is well established and there have been a number of reviews in this area [4, 9-12]. With reports of: (a) acceleration of reaction rates by factors of up to 3 orders of magnitude, (b) higher overall product yields and (c) reductions in unwanted side reactions improving product quality. [13, 14] Recent work has suggested that rate enhancements and regio-selectivity are caused by preferential energisation of functional groups/bonds; lowering of activation energies at catalytic sites; and/or selective microwave absorption of polar intermediates. [9, 15]. Currently, it is generally accepted that the observed benefits arise via enhanced heating rates and a volumetric heating effect through the bulk of the reaction mixture. [15, 16]

A good account microwave synthesis of nanomaterials is provided by [17], which includes a discussion of microwave applicator types and geometries, key components, their function and materials of construction. This paper also summarises a range of microwave based solvothermal synthetic routes to produce nanoparticles in a range of crystal morphologies from ZnO [18]. Hydroxyapatite doped with a number of lanthanoid elements in nanoparticles having a small particle size distribution (grain size 8 – 40nm) has also been reported. In this work, the nanoparticle size is controlled via the time and temperature of the reaction [19, 20], principally owing to the ability to accurately control microwave energy delivery to the reaction.

Microwave assisted extraction is also an important area. Applications include the remediation of oil contaminated drill cuttings, which has been achieved via selective heating of the aqueous phase and subsequent steam stripping of the hydrocarbon contaminants [21]. And in a similar manner, remediation of hydrocarbon contaminated soils [22]. Microwave Assisted Extraction (MAE) of valuable natural products from organic matter has also been

demonstrated, characterised by enhanced reaction time and yield without any degradation in product quality [23-25].

Microwave synthesis has also been applied to the synthesis of Metal Organic Frameworks (MOFs). A highly porous class of material comprising of a network-like structure of metal ions co-ordinated to organic ligands [26]. MOF synthesis via microwave heating has been shown to afford significant reductions in overall reaction time, in conjunction with a greater degree of control over the size distribution and morphology of the product crystals [27].

The application of microwave heating to polymer synthesis is also well founded. Radical initiated; ring opening; and step growth polymerisations have been extensively reported. [12, 15, 28, 29] .

The vast majority of this work has been undertaken using commercially available laboratory microwave equipment, typically producing only a few tens of grams. However, a range of larger scale systems has also been reported [30]. Translating positive laboratory results to commercial scale implementation of the technology is a recognised challenge.

In this paper we consider the commercially important class of step-growth poly-condensation systems, synthesised in a novel hybrid microwave reactor capable of producing up to 4.1 kg (5.0 litres) of a polyester resin. We then present an optimised processing regime which is used to synthesise a polyester pre-polymer 265% faster and with significantly enhanced process control, compared to samples produced in the same reactor using conventional (oil based) heating.

2. Integrating Electromagnetic Engineering with Chemical Systems

The performance of a process using microwave technology requires understanding and integration of a range of disciplines to achieve the desired outcome. Underpinning the

successful scale-up of microwave technology with chemical systems is the holistic consideration of the propagation of electromagnetic energy through a microwave applicator and its interaction with chemical mixture. This interaction is affected by a number of factors including: the dielectric properties of the individual phases within the mixture, the geometric configuration of the applicator – in which the material is treated, the means by which material is held/transported through it, and how microwave energy is delivered to the applicator. As a result, the design exercise is an iterative one in nature. Beginning with dielectric property measurements of the material(s) to be heated, which is then used to generate electromagnetic designs of the microwave system, which are improved upon until the desired outcome is achieved. This methodology has been established and used successfully in the design and evaluation of other large scale microwave systems. [5]

3. Experimental

3.1. System Configuration

The design of the microwave (MW) hybrid reactor is based on a commercially available 5l capacity oil jacketed steel reactor heated via a Julabo oil system (model HT60-M2). These vessels are currently used in industrial laboratories to research and develop polymer formulations before they are scaled up to commercial manufacture. Typically these are fitted with a glass or Polytetrafluoroethylene (PTFE) lid, in which a number of ports for distillation; charging of reagents, stirring and temperature monitoring are located. These need to be retained in microwave system, so a key activity in the design was a metal over-lid, a microwave in-feed section, and choking structures associated with each open port. These serve as a means of conveying microwave energy to the reagent mixture by creating the desired resonance and field pattern, whilst also sealing the system from the environment to prevent microwave leakage. The choking structures used were specifically designed to

attenuate the microwave field dependent on the materials in which they contain. For example, the distillation port consisting of a glass column; packing and the distillate material itself.

They serve as intrinsic safety systems which contain the microwave energy within the reactor, whilst still enabling open ports for the dean-stark distillation trap for example. This enables system compliance with Occupational Health and Safety (OHS) limits of $<5\text{mW}/\text{cm}^2$ and Electromagnetic Compatibility standards. [31]. A schematic of the system is shown in Figure 1.

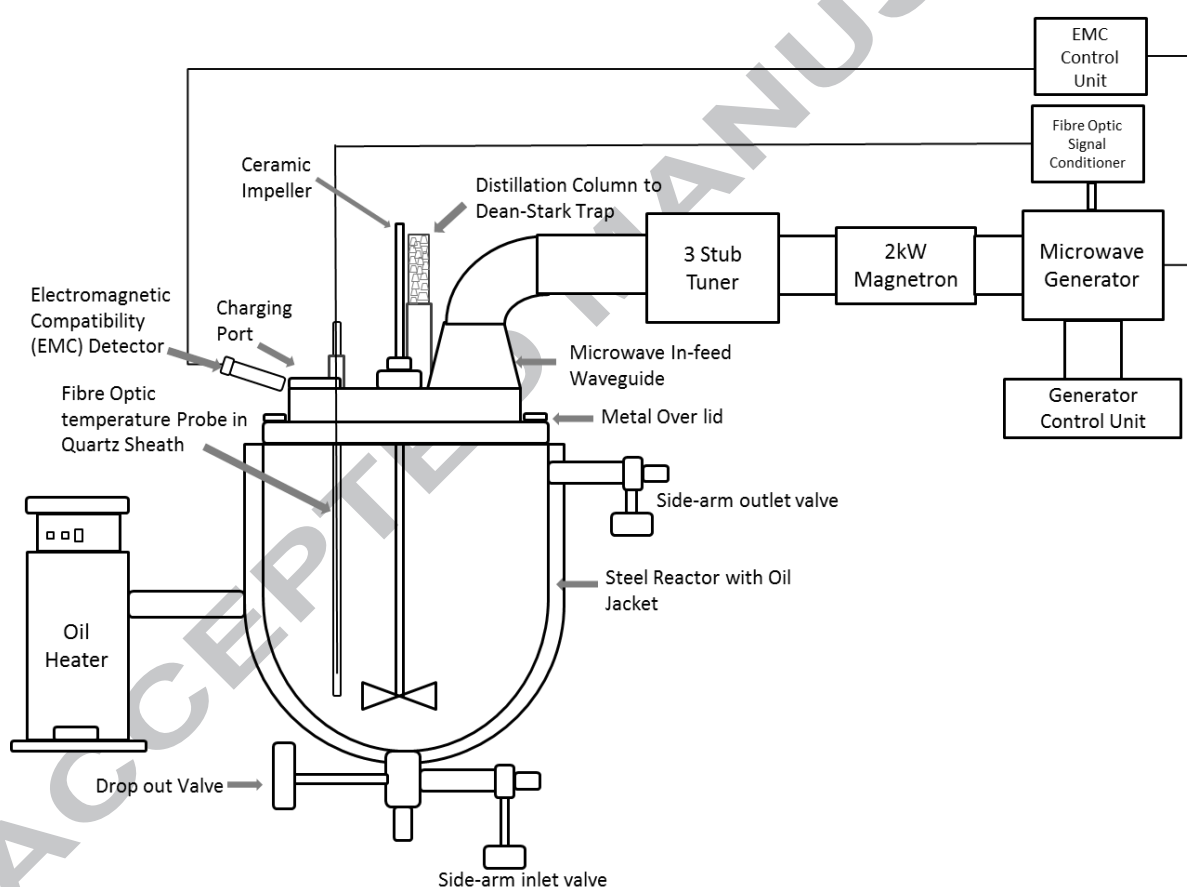

Figure 1: As-built 5L hybrid oil/microwave reactor

Microwaves are supplied to the reactor using 2 kW Sariem microwave generator operating at 2.45 GHz (model GMP20KIP56M230FST3IR). Reaction temperature is measured using a fibre optic temperature probe and associated signal conditioner (model FISO FTI-10), enclosed within a quartz sheath. The measured temperature is outputted to a Sariem generator

control unit (model GMP20KIPG3). This enables either a power or temperature set-point to be defined in order to control microwave power delivery to the main body of the reactor. Impedance matching is achieved using an S-Team 3-stub automatic tuning unit (model STHT). An Electromagnetic Compatibility (EMC) Detector (model MLT 442) is interlocked into the E-Stop line of the generator, to prevent microwave leakage from the reactor should the charging port be opened during microwave operation.

3.2. Design of the Reactor using Dielectric Properties and Finite Element Method (FEM) Modelling

The aim of the design process was to derive a system which optimises the interaction of the propagating microwave electric field with the reaction mixture. Acceleration in reaction rate is dependent on having the maximum volume of the reaction mixture being heated by the microwave energy – the previously mentioned volumetric heating effect. The spatial uniformity of the electric field intensity within the reactor itself is crucial to achieving a uniform heating of the reaction medium. In order to achieve this, electromagnetic modelling based on measured dielectric properties of the reaction mixture was developed to understand and to optimise the behaviour of the system during operation. This was based on the Finite Element Method (FEM), using COMSOL Multiphysics electromagnetic simulation software. The design procedure involved constructing a tetrahedral mesh of the reactor and reaction mixture. At each intersection point, Maxwell's equations were calculated to derive magnitude of the electric field and power density distribution (amount of power absorbed into the load), which together predict the heating behaviour of the reaction mixture during processing and thereby overall performance of the system. This then allowed the geometry of the key components – waveguide in-feed sections; metal lid and choking structures to be designed (section 3.3). Further details of the methods used are described in [32].

3.2.1. Dielectric properties of polyester resin

The dielectric properties of a material govern its interaction with the applied microwave energy and the resulting heating characteristics. [10] In this work we use the dielectric properties of a polyester in the electromagnetic design of the system. This is the same polymer used in the subsequent experimental work, further details of which are given in section 3.4. A 20 g sample of this polyester was synthesised in a Sariem Miniflow microwave reactor. This was intermittently sampled every 10 minutes and the dielectric properties measured by the cavity perturbation technique. [6] The cavity perturbation method was chosen as it is known to be better suited to measurements of low loss materials and can be used with granular materials whereby a <300mg of sample is held in a quartz tube. [33] As the requirement for the specimen size is very small, the sample is easily prepared and no calibration is required as the measurement are based on change in Q factor and resonant frequency between an empty and loaded quartz tube. The measurement error for ϵ' is less than 2 % [33] The error in the dielectric measurements of samples taken from the Sariem microwave reactor during the early stages of the reaction (10 – 120 min) and at elevated temperatures (>150 °C), was significant. Above 150°C, the sample continues to react within the measurement tube. This changes the chemical composition of the sample, making it non-representative of the mixture. Also loss of reactants through the poly-condensation itself and evaluation of bubbles within the sample changes both the total mass and volume during the measurement. This affects the volume and density of the sample and therefore does not accurately represent the bulk properties of the reaction medium, therefore introduced error into the measurement.

As such, for the purposes of designing the microwave reactor, the dielectric properties of the reaction mixture measured towards the end of the synthesis procedure (temperature 230°C and 300min) were used in the electromagnetic simulations of the system.

Table 1 presents dielectric properties at 2.45 GHz of the materials used for simulation. Samples of the polymer reaction mixture sampled after 300 min reaction time, and measured at 25°C and 230°C using the cavity perturbation technique. Dielectric properties of Quartz, PTFE and Syalon ® were extracted from literature.

Table 1: Dielectric properties of the reaction mixture and reactor components measured by the cavity perturbation technique [6]

Sample	Dielectric Constant (ϵ')	Dielectric Loss (ϵ'')
Polyester (at 25°C after 300min reaction time)	1.7	8.0×10^{-4}
Polyester (at 230°C after 300min after 300 min reaction time)	2.5	1.1×10^{-1}
Quartz	4.2	7.2×10^{-5}
Syalon ® ceramic	8.1	Lossless
PTFE	2.1	Lossless

3.3. Electric Field Propagation through the Reactor using Computer Simulation

The aim of this design process was to ensure that the physical dimensions of the reactor, in particular the inner and outer lid; waveguide in-feed section and reactor body itself, yield a homogenous electric field distribution within the system. This ensures that the energy can be

coupled effectively into the material and provide relatively uniform heating of the reaction medium. The power dissipation density in a material due to radio frequency heating is a function of internal electric field strength within the material, the frequency of the electromagnetic energy and the dielectric properties of the material. For a uniform electric field, the power dissipation density (P_d) is given by Equation 1 [34].

$$\text{Equation 1} \quad P_d = \omega \varepsilon_0 \varepsilon'' E^2 + \omega \mu_0 \mu'' H^2$$

Where P_d is the power dissipation density (W/m^3); ω is $2\pi f$ (rad/s) f is the frequency of applied electromagnetic energy (Hz); ε_0 is the permittivity of free space (8.854×10^{-12} F/m); ε'' is the dielectric loss factor; E is the electric field strength in the material (V/m); μ_0 is the permeability of free space ($4\pi \times 10^{-7}$ H/m); μ'' is the magnetic loss factor; H is the magnetic field strength in the material (A/m).

An extremely fine tetrahedral mesh (10 elements per wavelength) was generated in the system to improve the accuracy of electric field distribution. The model consists of 2631556 elements. The simulation was run on an Intel workstation with eight Dual Core 2.5 GHz Xeon processors, 192 GB RAM on a Windows 7 64 bit operating system.

3.3.1. Simulation Procedure

For the design procedure, the corresponding dielectric properties of the polyester: $\varepsilon' = 2.153$ and $\varepsilon'' = 0.11$ were used in the simulation (see Table 1). Figure 2 presents a 3D model of the hybrid system. The system is fed via a WR340 (86.36×43.18 mm) waveguide at a frequency 2.45 GHz. The stirrer is made from a technical ceramic which is a low loss, essentially microwave transparent material, with the inner lid being made of Polytetrafluoroethylene (PTFE). In order to maximise the homogeneity of the electric field and thereby microwave

heating, the geometry of the in-feed waveguide taper was optimised to allow the smooth propagation of the dominant mode (mode carrying the highest amount of energy) and to minimise any unwanted spurious modes (unwanted field propagation). This approach ensured that the transmission of the incident power to the load was maximised and minimised any power reflected back to the generator. Magnitude of simulation time was ca. 56 minutes.

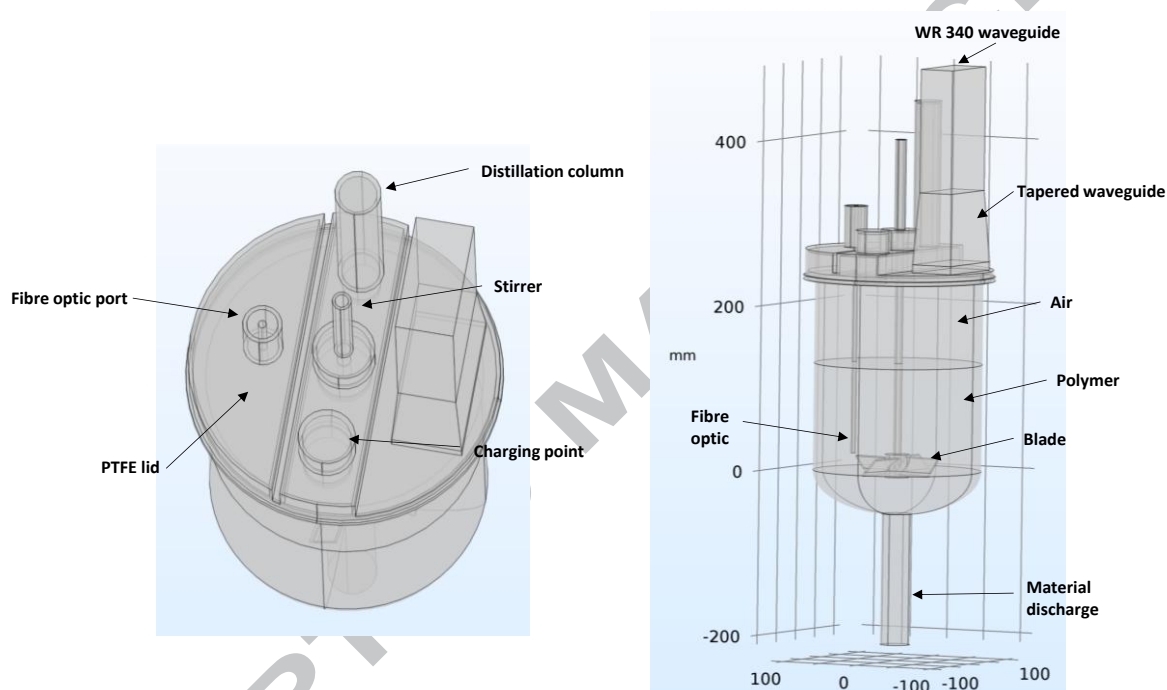

Figure 2: 3-dimensional model of the 5l reactor showing the final lid design, various ports; impeller stirrer, fibre optic thermocouple and microwave in-feed waveguide.

Figure 3 shows 3D electrical field distribution and in particular the microwave energy inside the main feed. [34] Despite the impeller blade and shaft being made from a low loss ceramic, some high field patterns are observed around the edges of the stirrer itself. This can be attributed to edge effects, whereby electric field concentrations occur at edges of materials exposed to the microwave field and the difference of dielectric constant between the two materials – in this case the edges of the impeller blades and the reaction mixture. However,

this effect is common in any microwave process and would occur naturally between materials with different dielectric properties.

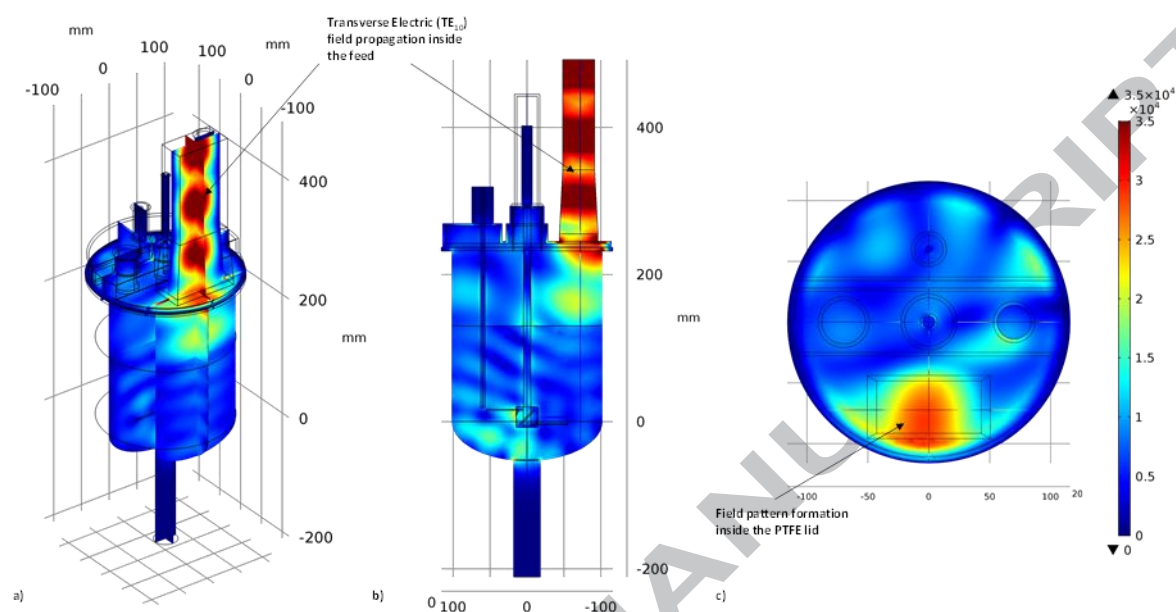

Figure 3: Electric field distribution inside the reactor, a) slice through the width of the waveguide, b) slice through the middle of the depth of the waveguide, c) slice through the top view of the lid side

It can be seen from Figure 3, that the highest electric field intensity is found within the waveguide sections of the in-feed port. This corresponds to the input energy from the microwave generator. It can be seen that the electric field intensity within the lower two-thirds of the reactor, which corresponds to the volume of the reaction mixture, is significantly lower because the energy is being absorbed via polarisation mechanisms of the reaction mixture itself, which is then subsequently converted to heat. It can also be seen that a resonant field pattern is established in the reaction mixture volume, which in conjunction with mechanical stirring, would yield volumetric heating, optimising the heating efficiency of the system and contributing the desired acceleration in reaction rate.

The system is designed to deliver maximum microwave energy during processing to the reaction mixture to optimise heating efficiency. The effect on absorbed power of impeller blade position within the reaction mixture was also evaluated. The simulation was repeated for impeller blade angles between 0 to 80°C in 10° increments, corresponding to one full rotation of the stirrer. Variation in absorbed power was less than 0.18% and therefore the rotating stirrer had no effect on heating profile of the reactor.

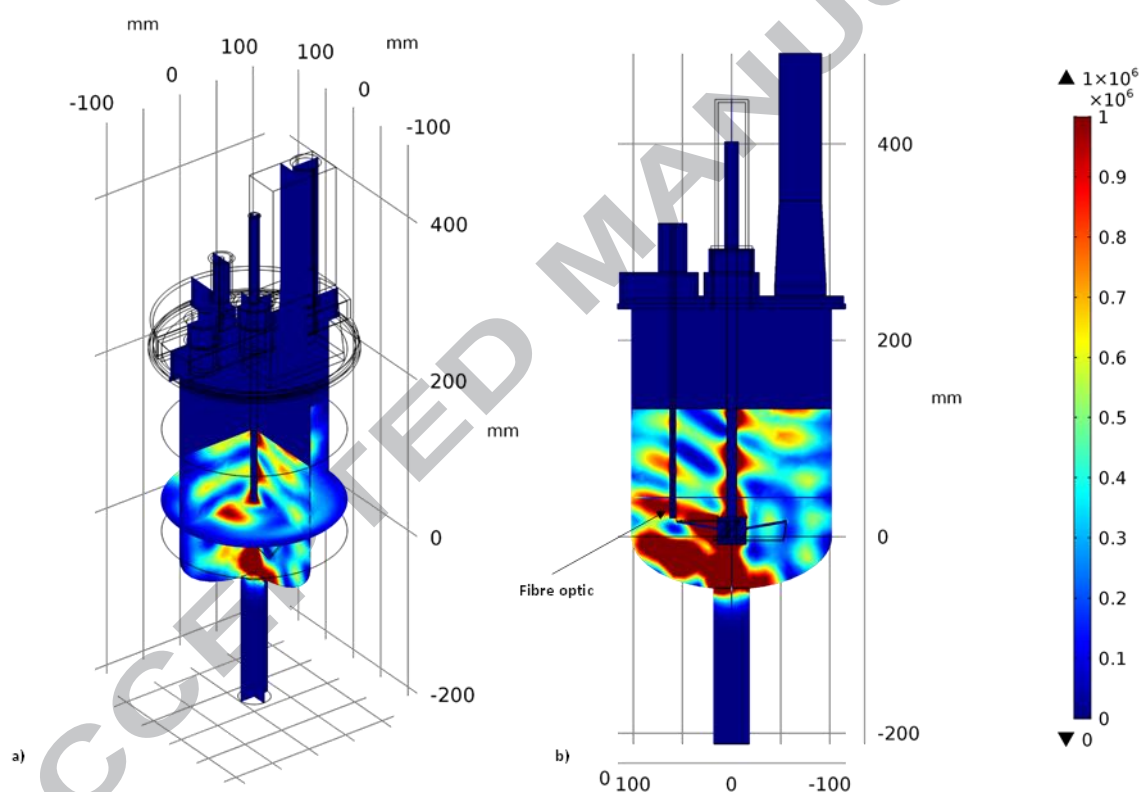

Figure 4: Power density distribution inside the load, a) Volumetric power density loss inside the reactor, b) cut 2D plan showing the stirrer and the fibre optic thermocouple

Figure 4 represents the power loss density inside the reaction mixture, with a total volume inside the reactor of 4.9 litres, corresponding to the mass sum of reactants producing the polymer with a density of 1.0g/ml. The field shows resonance (series of hot spots) inside the

material for a fixed position of the stirrer. The heating profile is greatest towards the opposite side of the microwave in-feed, this can be attributed to asymmetric configuration and the introduction of a glass sheath (containing the fibre optic temperature probe), which exhibits a possible higher order mode (Transverse magnetic TM_{01}) leading to a higher degree of heating. However, practically this is not an issue, as the stirrer rotates within the reaction mixture to provide higher homogeneity of treatment. It can be seen from Figure 4 (b) that the highest power distribution through the reaction mixture is on the far side of the reactor from the microwave in-feed. It also occurs within the lower portion of the reaction volume. The simulation shows multiple field resonance inside the reactor resulting in the propagation of a number of different modes (electromagnetic field patterns). This results in the reaction mixture being exposed to microwave energy through its entire volume, allowing homogeneous treatment, particularly when the stirrer is rotating. The simulations show that significant improvements in heating efficiency, compared to conventional heating from the reactor walls (oil jacket) are possible using this design approach.

3.4. Polyester Study System

The study system used in the experimental work is a polyester. While the specific applications of this formulation cannot be disclosed, it is a commercially available product and finds use in a number of important end-use sectors. In all trials, a fixed stirrer speed of 150rpm was used in accordance with the standard synthetic protocol for this polyester. It is synthesised in two stages. In the first stage a molar excess of di-hydroxyl is reacted with a di-carboxylic acid in the presence of a proprietary catalyst at 230°C until a clear resin is produced. Water of condensation is removed from the reactor via a distillation column and open dean-stark trap. After 24 hours, the reaction mixture is sampled and its hydroxyl concentration value (OH_v) measured by titration. A small addition of di-alcohol is added calculated from the reaction mixture OH_v and a defined set-point, to account for that which

may be lost during the distillation. Total yield at the end of stage one is 3.7 kg. In the second stage, a mixture of two di-acids is added and the reaction mixture processed until no further evolution of distillate is observed. The dean-stark trap is closed and a vacuum is then applied. The reaction is then continued until the measured concentration of acid groups falls below a defined set-point. The final polymer material is then discharged from the reactor. Total yield of the final stage two product resin is 4.1 kg

4. Results

The experimental programme evaluating the performance of the reactor consisted of two phases as shown in Figure 5. Firstly, the polyester is synthesised using a standard laboratory protocol provided by the industrial collaborator. This synthesis was undertaken using both Conventional Heating (CH) and Microwave Heating (MWH). The objective of this was to benchmark the system performance to evaluate using the standard synthesis regime, what impact, if any, there was of the heating mode, on the properties of the final product.

In the second phase of the experimental programme, the stage 1 synthesis of the polymer was optimised using MWH, so that the process benefits of the microwave based reactor could be quantified. This was chosen because the stage 1 polymer is typically synthesised in 24 hours, as opposed to up to four days for the final polymer. This enabled more trials to be conducted in a given time-frame, as the focus at that point was to evaluate the performance of the microwave reactor. The optimisation involved achieving the greatest acceleration in reaction time, balanced with minimising mass of di-ol lost through co-distillation with the condensate water. This reflects the commercial value of any process improvement – in this case, reducing vessel cycle time via increasing batch production rates and minimising time taken for in-process adjustment due to reagent loss through processing.

The standard laboratory synthesis regime used in the AkzoNobel commercial development laboratories for the study polyester was not optimised to yield the greatest acceleration in reaction time. Rather the regime was typically used to investigate formulation changes and thereby was one of convenience. However, the heating profile of the standard synthetic regime was tailored to minimise co-distillation of the di-ol with the water of condensation - so called glycol losses. This was achieved by using a relatively slow rate of reaction temperature increase to 230°C, generally <10°C/hour.

Given this, a set of secondary control trials were required, in which the optimised reaction profile derived from MWH trials was replicated (as far as possible) using conventional oil heating. This then gave a robust evaluation of the process benefits of reactor operated in microwave heating mode.

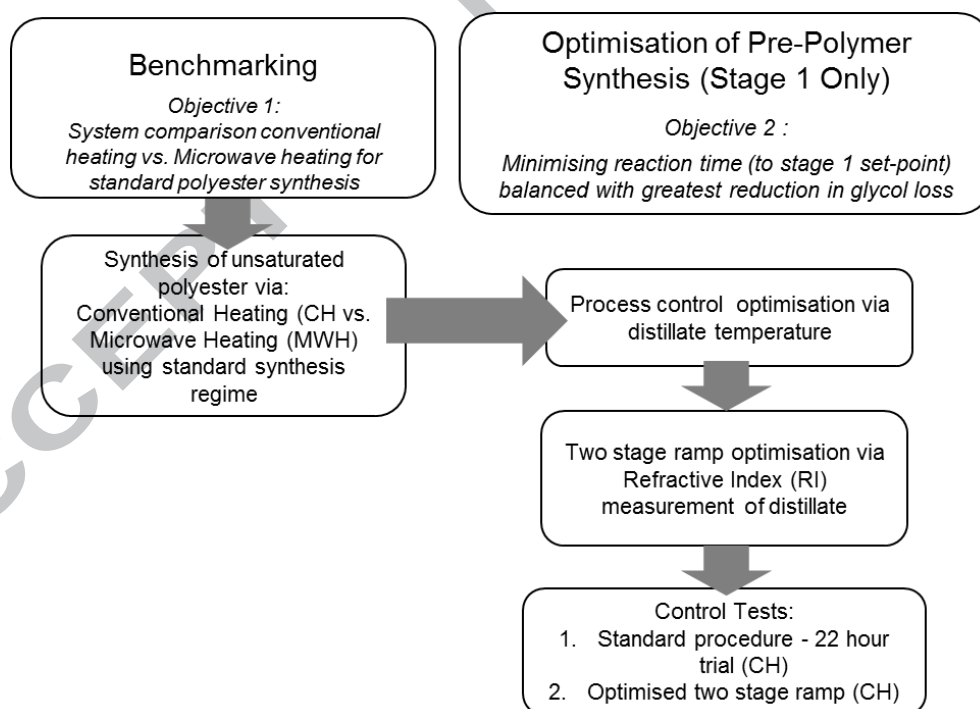

Figure 5: Overview of the experimental regime used to evaluate the performance of the 5l hybrid microwave polymer reactor

4.1. Conventional vs. Microwave Synthesis

In the first phase of the experimental work comparison between syntheses of the polyester using Conventional Heating - CH (oil heated jacket) and Microwave Heating (MWH) was undertaken. This was to evaluate if the product composition was equivalent irrespective of heating mode used. An aspect of critical importance when subsequently looking towards further scale-up of the technology. For these trials using CH, following addition of the reagents, the reaction temperature was increased at a rate of $6^{\circ}\text{C}/\text{h}$ to reaction temperature of 230°C using a programmable function of Julabo oil heater. For the MWH trials, the forward input power was manually adjusted to keep the heating rate as close to the CH control trial as possible. After 8 hours, the system was programmed in 6 automated steps to increase the reaction temperature to 230°C applying a power of 800W - the average used over the manual adjustment of the power input during the first 5 hours of the synthesis. The temperature profile for these trials is shown in Figure 6 for the stage 1 reaction. It can be seen that during the first 8 hours of the synthesis the temperature profiles are comparable. However, during the MWH trial, six temperature set-points were pre-programmed into the microwave generator control system using a constant input power of 800W. Once the temperature set-point is reached, the system cycles the power on and off to maintain the set-point for a defined amount of time, before implementing the next. During the six ramp phases, the incremental temperature rise was $\sim 46^{\circ}\text{C}/\text{h}$ between the temperature set-points. It is suggested that the reason an input power of 800W yielded a higher than expected increase in reaction temperature at each set point, is due to a smaller volume of condensate water being evolved as the reaction progresses. Energy lost from the system is proportional, in part, to the rate of condensate distillation. As the rate at which evolved water is distilled drops, energy is retained in the reaction mixture and so yielded a higher ramp in temperature between set-

points. This is expected in a step-growth reaction mechanism, as the monomer concentration decreases as oligomeric units are formed. In both cases (microwave and conventional synthesis), the total yield of polyester was 3.7kg.

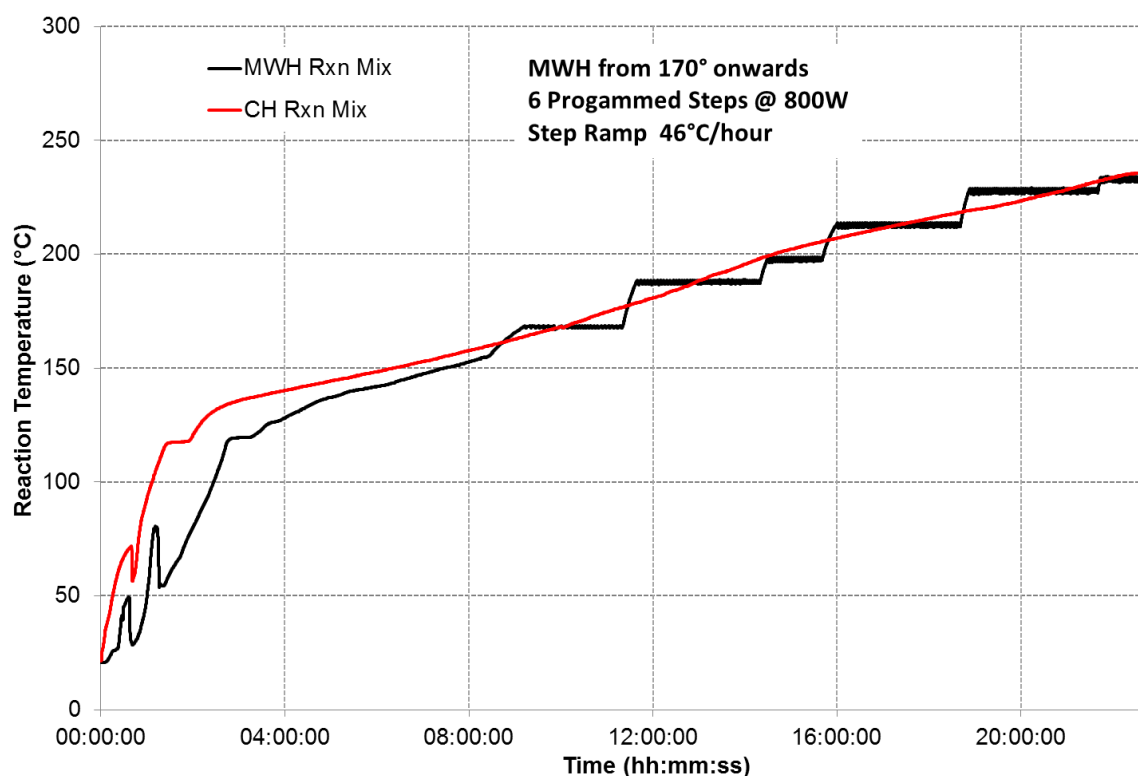

Figure 6: Comparison of reaction mixture temperature of CH vs. MWH synthesis of polyester during in the first stage

The product was characterised using Nuclear Magnetic Resonance (NMR) and Gel Permeation Chromatography (GPC). ^1H (δH) NMR spectra were recorded at 25 °C using a Bruker DPX-300 spectrometer (300 MHz) or Bruker AV-400 (400 MHz) and chemical shifts were recorded in δH (ppm). Samples were prepared as solutions in either deuterated chloroform (CDCl_3) or deuterated methanol (MeOD), depending on conversion level to which chemical shifts were referenced (residual chloroform at 7.26 ppm, residual methanol at 3.31 ppm). Analysis of the spectra was conducted using MestReNova 10 software. GPC analysis was performed using an Agilent 1260 Infinity series High Performance Liquid

Chromatogram (HPLC) with an online degasser, isocratic pump, automated liquid sampler, thermostatted column oven and differential refractive index detector. The columns used consisted of 2×7.5 mm I.D. by 300 mm L - Agilent PLgel Mixed E, 3 μ m particle size Columns (Linear Separation range – up to 25 kg.mol⁻¹ relative to Polystyrene). With a 7.5mm ID by 50 mm L – Agilent PLgel 3 μ m column guard. The eluent used was tetrahydrofuran (THF), HPLC grade, ≥ 99.99 %, inhibitor free. Preparation of sample involved dissolving the sample in THF (1 – 2 mg/mL) and then passing the sample through syringe filters (Whatman, 25 mm, 0.2 μ m). Once dissolved, the analysis was conducted by flowing the sample through the columns at 1 mL/min at 40 °C. Data was analysed using Astra 6.1 software (Wyatt technology, USA). An in depth account of the methods used in this work (and others) to characterise the polymer can be found in [35].

Compositional analysis of the polymer material confirms that the benchmarking samples are of equivalent molecular composition. NMR and GPC data is shown in Table 2. The stage 2 polymer synthesised via microwave heating has a marginally higher molecular weight average (M_w) compared to the conventional equivalent. It also has a higher Dispersity (\mathcal{D}) indicating that the distribution of molecular weights of the polymer is higher and would be expected in step-growth polymerisation.

Table 2: CH vs. MWH benchmarking samples compositional data by NMR and GPC

Heating Mode	Stage	NMR	GPC			
		M_n	M_n (g.mol ⁻¹)	M_w (g.mol ⁻¹)	M_p (g.mol ⁻¹)	Dispersity (\mathcal{D})
CH	1	2,200	2,500	5,200	5,000	2.36
MWH		2,050	2,400	4,900	4,600	2.39

CH	2	2,410	2,700	9,000	9,000	3.37
MWH		2,650	2,700	9,800	9,600	3.69

Note: M_n – number average molecular weight; M_w – weight average molecular weight; M_p – peak average molecular weight

For reference, GPC chromatograms for CH and MWH runs are shown in Figure 7. Again the results confirm that irrespective of whether the heating mode is via the oil jacket (CH) or by microwave (MWH), the synthesised polymer material is of equivalent composition under comparable processing conditions.

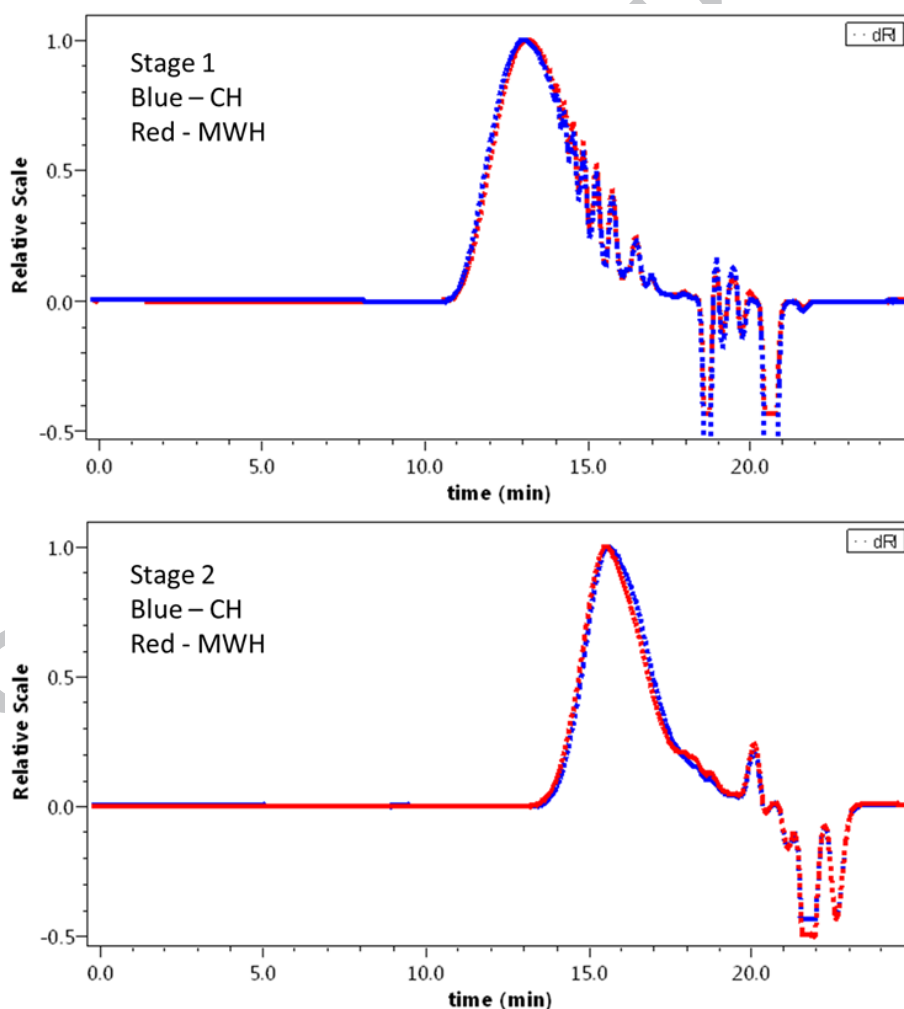

Figure 7: GPC chromatograms of polyester synthesis under CH and MWH

4.2. Optimisation of first stage synthesis under MWH

The benchmarking trials demonstrated that the hybrid 5L system could be used to synthesise polymer product under microwave heating with equivalent composition to that produced using a conventional oil heated jacket in the hybrid system. Subsequent work then sought to optimise the processing regime of the stage 1 synthesis to achieve the maximum increase in reaction rate, whilst maintaining reagents within the reaction vessel, thereby minimising glycol lost to the distillate.

4.2.1. Optimisation Trials

An issue in this synthesis, is the co-distillation of unreacted di-ol with the water of condensation, as the reaction proceeds. Given a reaction temperature of 230°C and a distillation temperature of the di-ol of ca. 200°C, the optimisation trials sought to seek a balance between increasing the reaction rate, whilst maintaining the maximal amount of di-ol (glycol) in the reactor. Thereby minimising so-called glycol losses. The target loss was <10mg KOHg⁻¹ (herein referred to as unit loss). A qualitative assessment of glycol losses is used during stage 1 of the standard synthetic regime. This is as follows: Low (<5 units); Medium (5 – 10 units); and High (>10 units).

Given the distillate temperature is proportional to glycol content of the evolved distillate, a K-type thermocouple was used to measure the temperature at the head of the distillation column. By monitoring this temperature, an estimation of the impact of processing conditions – reaction temperature as a function of applied microwave power, could be made to optimise the process. The general form of the optimisation procedure is shown in XXX.

An exemplar sighter trial is shown in Figure 8.

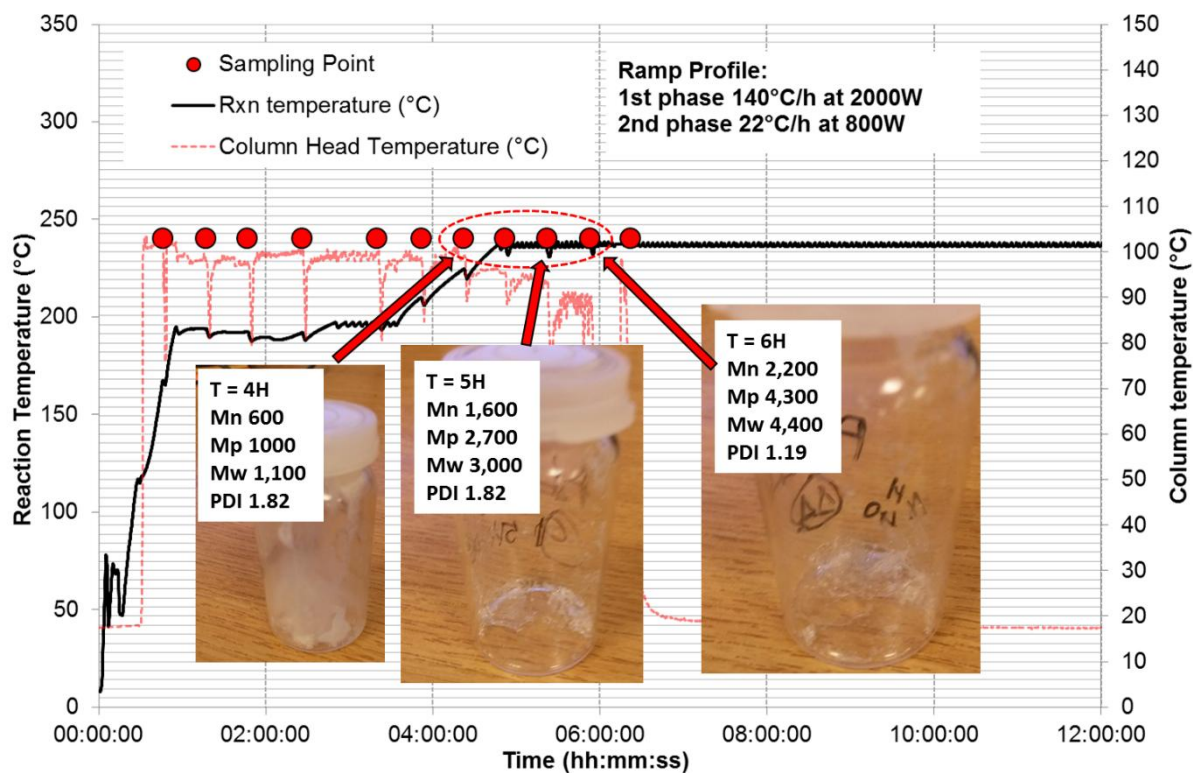

Figure 8: Typical temperature profile of the MWH two stage ramp optimisation trials. Images show the transition to reaction mixture clarity corresponding to consumption of the monomer reagents.

A two stage ramp was derived for MWH of Stage 1. This was based on monitoring of the temperature at the head of the distillation column. Following the addition of the acid and catalyst, the reaction temperature is increased at a rate of 140°C/h at full power (2000W) to just below the boiling point of the glycol (195°C). Then held at this point using a power of 700-800W until the distillate temperature, measured at the head of the Dean-Stark apparatus, drops to 2°C less than its value at the start of the distillation. This was then considered to be when the rate of reaction slowed, thereby evolving less water and causing the corresponding drop in distillate temperature. At this point, the temperature is increased to 230°C by applying a power of 800W, which yielded a 2nd stage ramp of 22°C/h . The reaction mixture was sampled intermittently throughout the first ca. 6 hours of the reaction. These samples were submitted for GPC analysis, as well as evaluated for clarity of the mixture. Clarity is an

estimation of when at least one of the acid functionalities of the di-acid have reacted in the polymer, thereby rendering any remaining di-acids soluble in the molten polymer. It is used as a visual quality control check to ensure that any samples collected from the mixture are representative for subsequent analysis (typically via GPC).

This is a good estimation of when the reaction is complete, because for this particular polymer system, the di-acid remains as a suspension, causing the reaction mixture to appear cloudy until fully reacted, after which a clear resin is produced. For industrial production, this is an important qualitative check, as sampling before the batch has reached clarity can result in erroneous results on analytical quality control testing – due to the potential inhomogeneous distribution of the di-acid within the reaction mixture. It can be seen from Figure 8 that the transition to clarity in these trials, occurred between 5 and 6 hours after the start of the reaction. The temperature is then maintained until 24h after the addition of the acid and catalyst, before discharging the material from the reaction vessel. This was then repeated in triplicate. The time to reaction temperature was 3 hours, giving an overall ramp rate of ca. $61.7^{\circ}\text{Ch}^{-1}$. Average di-ol loss for these triplicate runs was $14.3 \pm 4.2 \text{ mgKOHg}^{-1}$.

4.2.2. Optimisation by Distillate Refractive Index

The overall glycol loss in the optimisation runs was still considered prohibitively high as they fell into the qualitative range >10 units. Sighter trials had shown that attempting to raise the reaction temperature $>190^{\circ}\text{C}$ within the first 2 hours of the reaction caused an excess co-distillation of the glycol monomer from the reactor and corresponded to a measured increase in the distillate temperature. To further optimise the processing regime, the glycol content of the distillate was quantified by refractive index (RI) measurement, calibrated against aqueous solutions of known glycol concentration

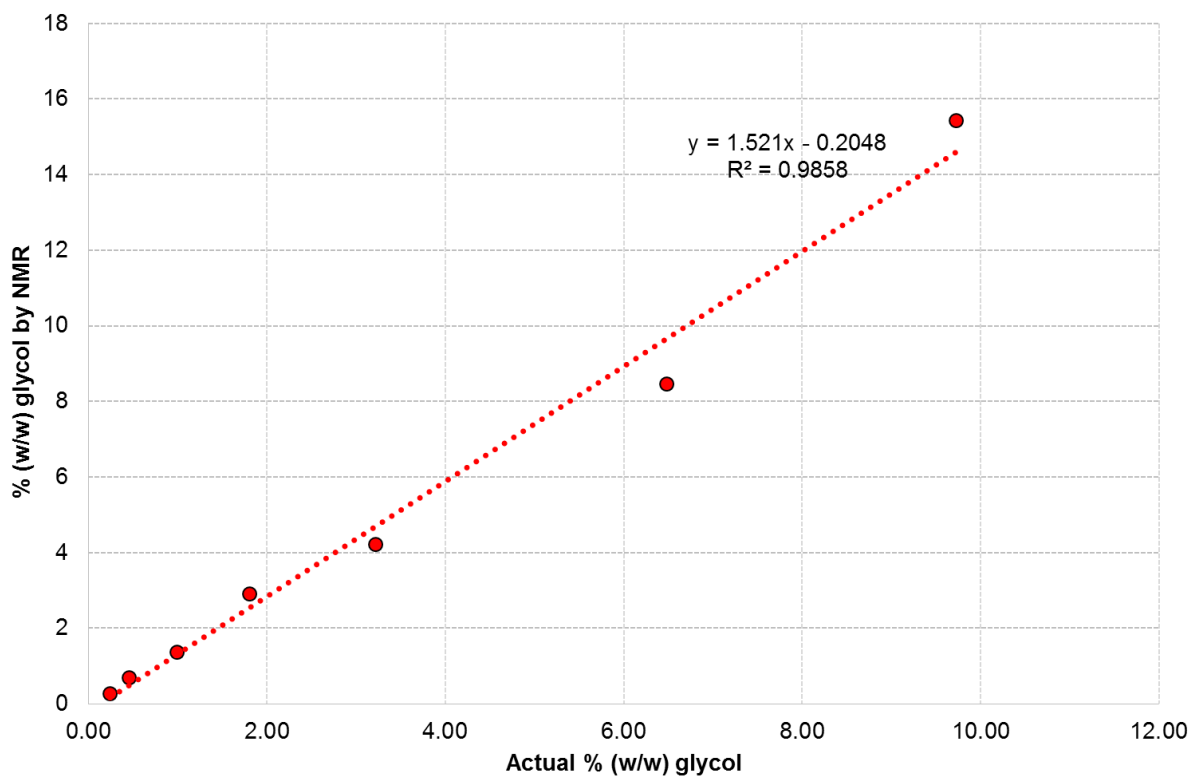

Figure 9: Calibration plot used to calculate glycol content of distillate aliquots collected

The distillate was collected in 30 – 40 ml aliquots and the refractive index immediately measured. This enabled the processing regime to be further optimised to minimise glycol losses, balanced against the fastest reaction rate, in real time, as the reaction progressed.

Two processing regimes were investigated, denoted as a ‘fast’ and ‘slow’ ramp to the reaction temperature. The refractive index of these was measured after filtration through a 0.2 μ m PTFE filter, as traces of the di-acid had also been previously identified in the bulk distillate. The reaction temperature profiles and corresponding measured RI of the collected distillate samples is shown in Figure 10.

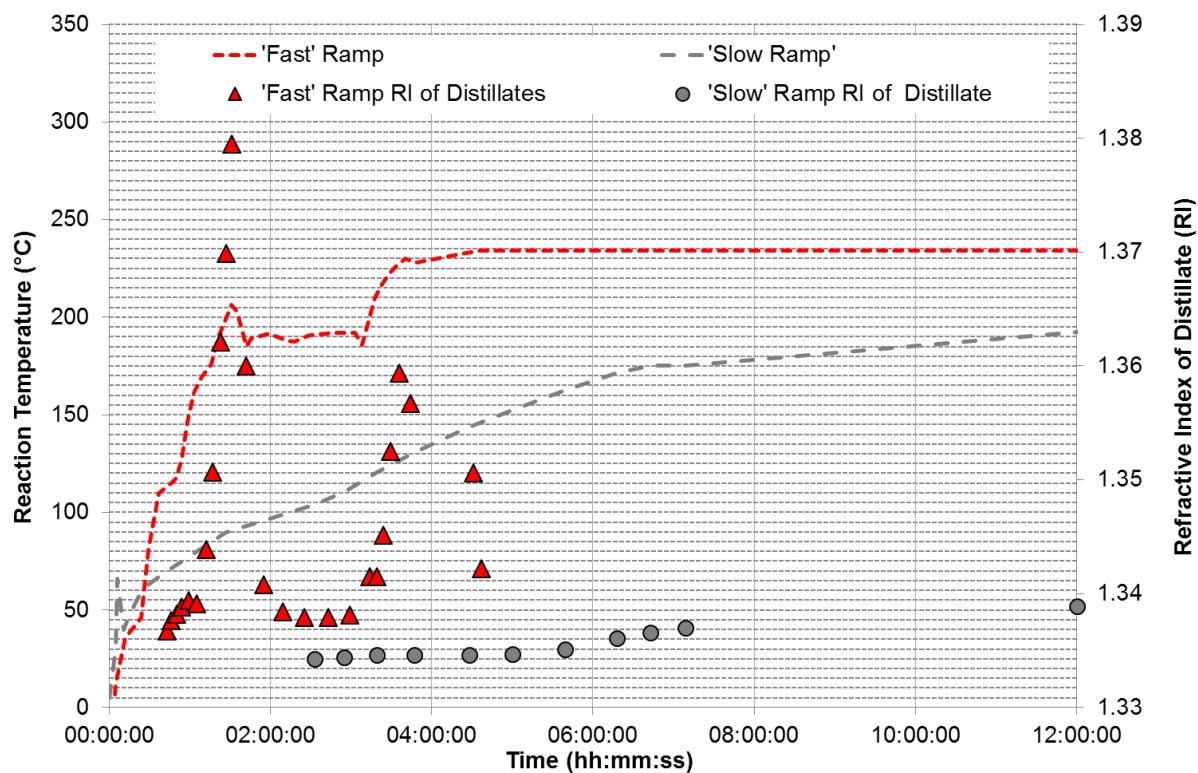

Figure 10: Effect of temperature ramp rate on co-distillation of di-ol with water of condensation during stage 1 polyester synthesis

In the 'fast' trial, to further reduce overall processing time, the temperature was increased straight through to 230°C at 1400W. However, by monitoring the RI of the distillates, it can be seen significant increase in RI is observed when the reaction temperature approaches 170°C, peaking at 200°C at the boiling point of the di-ol. At this stage, the temperature was dropped and maintained at 195°C, then ramped again (much like the initial MWH sighter tests) to the processing temperature. This again correlated with an increase in RI, and thereby di-ol content of the distillate, was well as an increase in distillate temperature (not shown in the figure). Reconciling the mass balance by RI (85.5g) with that measured by OHv (85.7g), showed excellent agreement in this case for evaluating the loss of the di-ol during distillation of the condensate of reaction. The glycol loss in this trial was 23.8 units, much higher than the initial two stage ramp profile. It can be seen from Figure 10 that the spikes in RI measurement (and therefore di-ol concentration) in the distillates of the 'fast' trial,

correspond to the rapid increases in reaction temperature between 120 - 200°C and again at 195-230°C. The results also demonstrate that excellent process control over energy delivery to the system is achievable. Dropping the applied microwave power from 1400W to 0W when the reaction temperature reached 206°C (corresponding to the highest measured RI of the distillates) immediately resulting in both a drop in reaction temperature and also RI of the subsequently collected distillate fractions, demonstrating a low degree of heat latency within the system.

In the 'slow' trial, a moderate applied power of 450 – 700W was used and adjusted to achieve a steady increase in reaction temperature, the overall ramp rate was around 19°C h⁻¹. The overall di-ol loss measured by OHv was 6.2 units (21.9g) and the mass balance by RI 7.6 units (27.5g). It can be seen that reducing the ramp rate results in a significant drop in overall glycol loss, compared to the 'fast' run, but this is at a cost of an increase in processing time. By increasing the reaction temperature at a slower rate, a greater fraction of di-ol can react to form oligomeric units, resulting in less free di-ol to be co-distilled with the water of condensation.

4.3. Optimised Stage 1 Microwave Synthesis

The previous trials showed that increasing the reaction temperature prematurely – before monomeric units have reacted to oligomers, results in excessive loss of di-ol from the system. Further trials, ultimately led to a modification of the two stage ramp, whereby the reaction mixture heated at 1400W then held at a temperature of 170°C for 2 hours using an applied power of 700 W in order to react the monomeric units to form oligomers, then heated at a slower rate of 27°C h⁻¹ to 230°C using 800W. The optimisation procedure used in this work is summarised in Figure 11.

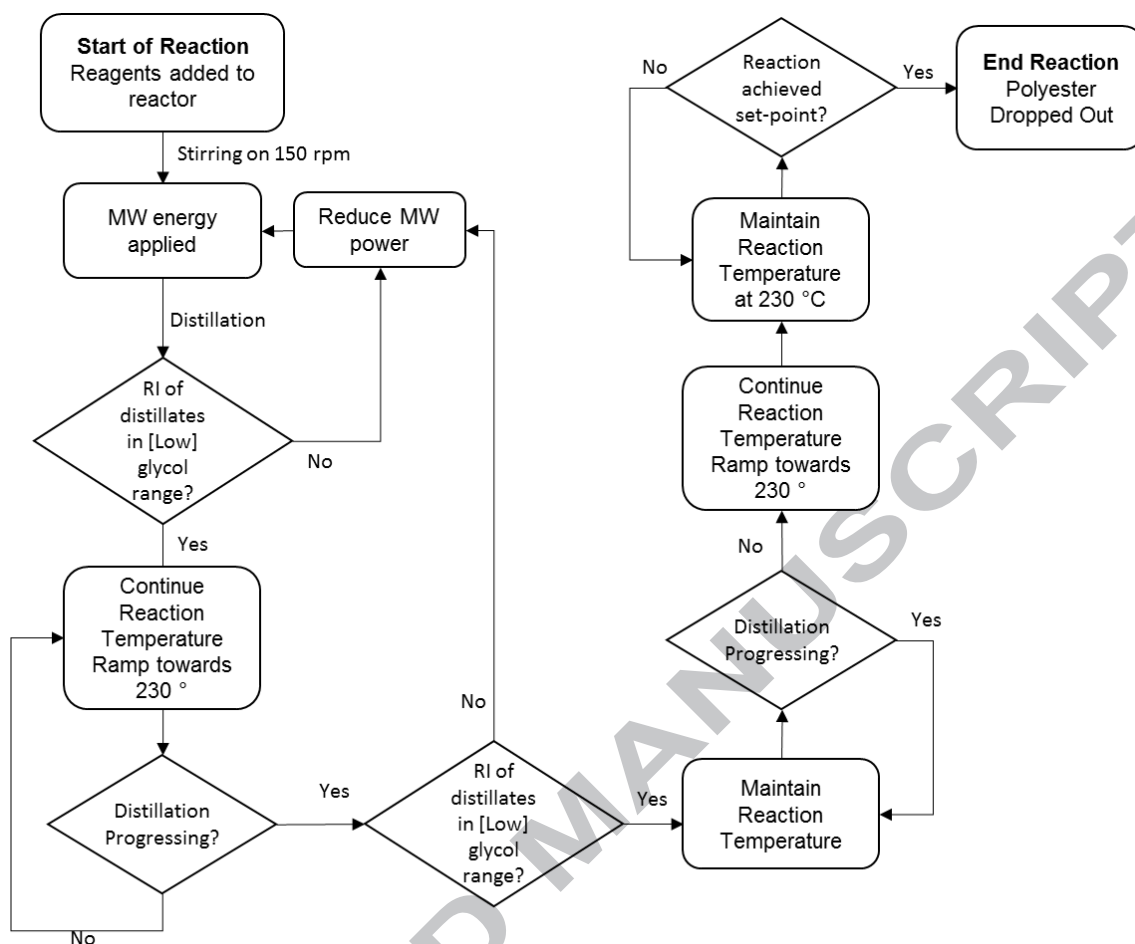

Figure 11: Process optimisation procedure used for synthesis of the polyester study system

The optimised trial was repeated in triplicate with sampling of the reaction mixture every hour during the first two runs and without sampling in the final one to evaluate the effect which this may have had on reaction rate and glycol loss. This was undertaken since the microwave system is switched off during sampling of the reactor and opened through the charging port to collect. The reaction profile and cumulative loss of glycol is shown in Figure 12. Note the shaded area in the figure is the standard deviation in the temperature over the triplicate repeat runs. This was compared to a control run in which the same heating profile was replicated using conventional (oil) heating, in order to differentiate the performance of the two heating modes applied to the same reactor.

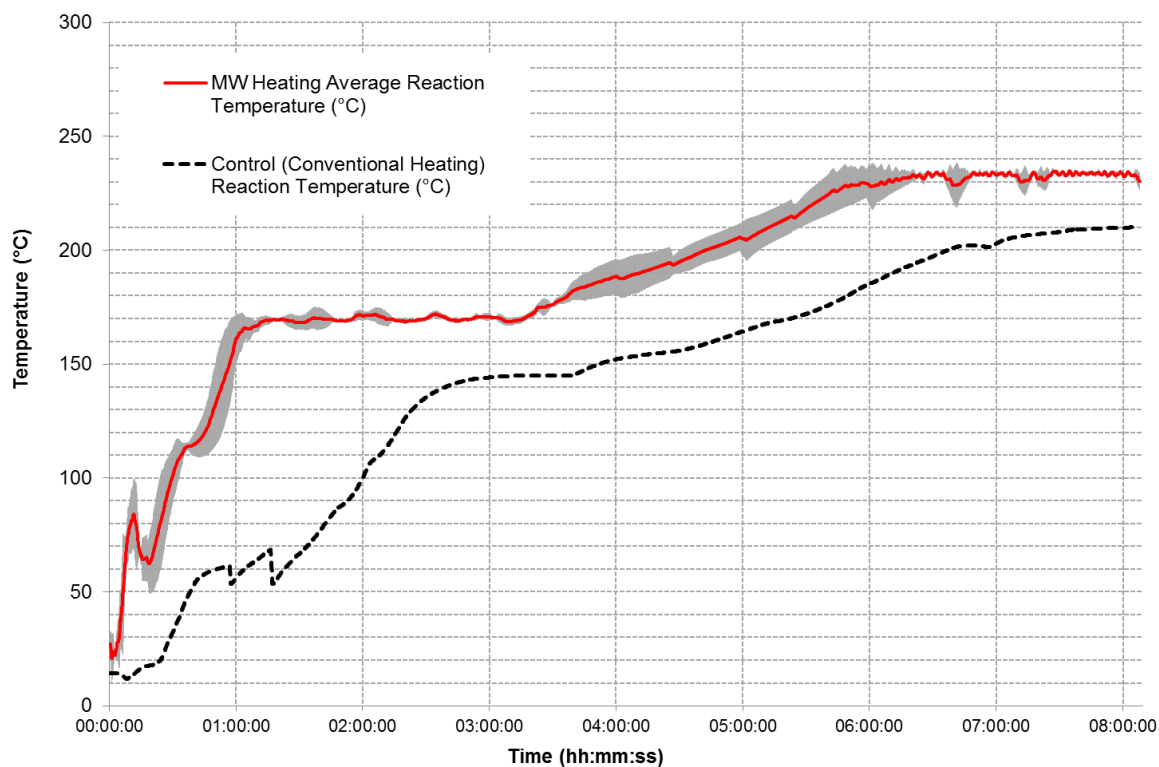

Figure 12: Reaction profile of the optimised two stage MWH process, compared to the same two stage ramp using CH. Note shaded area is temperature standard deviation over the triplicate MWH repeats.

Considering the MWH runs, it can be seen that the ramp stages (time 00:00:00 to 01:00:00 and ca. 03:15:00 to 06:30:00), had a greater variability in temperature compared to the temperature maintenance phases. This is because across the three runs, a fixed microwave power is used. Therefore energy delivery to the system can be very accurately controlled. The variability observed is attributed to the balance of input power and heat losses to the wider environment. These heat losses being proportional to ambient air temperature. For example, a series of earlier triplicate tests was undertaken to examine the variability in glycol loss without operator input into the reaction. On addition of the di-acid and catalyst to melted di-ol, a fixed microwave power of 800W was applied until the reaction temperature was achieved. It was observed that, with all other variables constant, when the ambient air

temperature was 16°C, time to 230°C was 05:41 (hh:mm), whereas at 20°C, the time was 05:20 (hh:mm). An 21 minute increase, attributed to a reduction in heat losses from the reactor to the environment as the ΔT is marginally lower.

Compositional data including measured OHv and AV data is presented in Table 3. It can be seen from the table that sampling at 1hourly intervals of the reaction mixture has an effect on both overall glycol loss from the system and the overall conversion of monomeric units to relatively high molecular weight oligomer and polymer. It can be seen from Table 3, that intermittent sampling of the reactor, in which the MW's were switched off for approximately 5 minutes, showed that this had an effect on both glycol loss and overall molecular weight. Resulting in a reduction in M_w of ca. 300 gmol^{-1} , compared to the trial without sampling.

Table 3: Compositional data for the triplicate optimised processing regime compared to replicating the two stage optimised procedure using oil heating (CH1) the standard reaction procedure (CH2)

Run No.	Reaction Time ^a (hh:mm)	Acid Value (mgKOHg ⁻¹)	Glycol Loss by OHv (mgKOHg ⁻¹)	Glycol Loss by RI (A.U)	GPC			
					M _n (g mol ⁻¹)	M _w (g mol ⁻¹)	M _p (g mol ⁻¹)	Dispersity Đ
MW1	08:21	16.2	2.8	2.3	2,100	3,900	4,000	1.86
MW2	08:05	21.4	3.9	1.7	1,800	3,800	3,700	2.11
MW3*	08:21	11.6	3.1	2.0	2,100	4,900	5,100	2.33
CH1	08:50	21.8	n.a.	1.8	1,600	2,800	2,600	1.75
CH2	22:15	29.4	Not measured	Not measured	1,200	2,500	1,600	2.08

Note: ^a – reaction time defined as time between first addition of di-ol and discharge of product; * - no intermittent sampling of reaction mixture at hourly intervals. n.a. – not applicable

In order to differentiate the effect of the heating mode (oil or microwaves) from the operating regime, an attempt was made to replicate the optimised two stage heating regime using oil jacketed heating. In this case, the ramp profile of the oil temperature was set to match that of the MW based tests (Table 3 run No. CH1). It can be seen from Figure 12 that a significant lag in the bulk reaction temperature was observed. This is attributed to thermal lag within the reaction mixture on account of heat transfer from the heated walls the centre of the reactor. Whereas in the MW heated case, heating through the bulk of the reaction mixture, greatly reduces the spatial temperature differential and enables the target reaction temperature to be achieved quicker.

It can be seen from Table 3 that at an equivalent reaction time the measured AV of CH1 is significantly higher than that found in run MW3. This corresponds to a higher concentration of monomer and polymer units with acid functional groups remaining unreacted and a therefore lower conversion. Higher measured acid values are associated with a lower degree of conversion [36]. It can therefore be concluded that the optimised MW heating regime is in excess of 265% faster than conventional heating in the same reactor. Note that the measured AV of CH1 at 22:15 (hh:mm) from the start of the reaction, was still 29.4 units, some 14 units above that at which the reaction is considered complete. Extrapolating the drop in acid value calculated from GPC data taken from the last three samples collected during the trial suggests the reaction would have been complete in 23:20 (hh:mm), suggesting a potential increase in reaction rate to the equivalent acid value set-point of 279%. Furthermore, comparing this to the attempted replication of this test (Table 3 CH2) using oil heating, showed in this case, conventional heating was unable to match the performance of the microwave system. Characterised by significantly higher AV (29 vs. 12 mgKOHg⁻¹) on the final sample and lower molecular weight of the polymer product.

The performance of this system has been evaluated using a polyester resin. However, it could be used to process a range of other polymer types, including alkyds and polyamides. Currently this hybrid system does not have any effective capacity to cool the reaction mixture, so would be unsuitable to evaluate the synthesis of polymer resins with any significant exotherm associated with them. In addition, the performance enhancements reported in this paper are specific to the evaluated polyester. It is reasonable to suggest that significant enhancements in both reaction rate, and process control are also achievable for other polymer resin systems, provided that both volumetric and selective heating effects from which the process benefits are derived are retained in each case. Quantification of such benefits must be derived from extensive reactor specific synthetic optimisation programs, as

reported in the present work. It would be possible to develop a more generalised approach to this optimisation program. However, this would require significant automation of the system, as the dominant processing issues for each resin class can change. This automation would likely require a potential range of in-line sensors (for detecting glycol in the distillate for example), from which compositional information could be inferred, then feeding back into the reaction control system. While certainly possible, this was not the focus of the present work.

5. Conclusions

A hybrid chemical reactor capable of producing up to 5L of polyester resin per batch has been designed and built. The system is based on an existing oil jacketed reactor. In this design we have adapted using an inner PTFE and outer metal lid such that microwave energy at 2.45GHz can be applied at a power of up to 2kW to the reactor body itself. The volumetric heating effect of microwave energy has been exploited to optimise the synthesis of a polyester study system, by controlling glycol losses to a Dean-Stark trap. This has yielded a two stage heating profile of the reaction mixture that can produce ca. 4 litres of resin prepolymer at least 265% faster than the current reaction procedure for this resin. Attempting to replicate this optimised reaction profile using conventional (oil heating) showed a significant thermal lag within the reaction mixture. This was characterised by relatively low number average molecular weight (M_n 1,200) and high acid and hydroxyl value (21.8 and 62.2) respectively suggesting incomplete conversion of oligomeric units to the target polymer. The optimised reaction procedure gave a polymer with number average molecular weight (M_n) of 2,100 and acid and hydroxyl values of 11.6 and 47.7 respectively in a reaction time of only 8 hours 20 minutes. Compared to the standard reaction procedure M_n 1,600 with acid value

29.4 and hydroxyl value 56.4 in 22 hours 15 minutes. The enhancement in synthesis rates is attributed to volumetric heating of the complete reaction volume as described by the electromagnetic simulations undertaken during the design phase of the work.

Acknowledgements

This work was supported through an Engineering and Physical Sciences Research Council (EPSRC) Impact Acceleration Account (IAA) Award.

ACCEPTED MANUSCRIPT

References

1. (GmBbH), P.M.r.G.P.C.M.I., *World Plastics Production 1950 - 2015*. 2016.
2. Joseph Schork, F., *Design and Operation of Polymerization Reactors*, in *Monitoring Polymerization Reactions*. 2013, John Wiley & Sons. p. 345-361.
3. Stankiewicz, A.I. and J.A. Moulijn, *Process intensification: transforming chemical engineering*. Chemical engineering progress, 2000. **96**(1): p. 22-34.
4. Lidström, P., et al., *Microwave assisted organic synthesis—a review*. Tetrahedron, 2001. **57**(45): p. 9225-9283.
5. Buttress, A., et al., *Towards large scale microwave treatment of ores: Part 1—Basis of design, construction and commissioning*. Minerals Engineering, 2017. **109**: p. 169-183.
6. Smith, A.D., et al., *Dielectric properties of free-radical polymerizations: molecularly symmetrical initiators during thermal decomposition*. Industrial & Engineering Chemistry Research, 2010. **49**(4): p. 1703-1710.
7. Smith, A.D., et al., *Temperature Dependence of the Dielectric Properties of 2, 2'-Azobis (2-methyl-butyronitrile)(AMBN)*. Industrial & Engineering Chemistry Research, 2010. **49**(6): p. 3011-3014.
8. Adlington, K., et al., *Mechanistic investigation into the accelerated synthesis of methacrylate oligomers via the application of catalytic chain transfer polymerization and selective microwave heating*. Macromolecules, 2013. **46**(10): p. 3922-3930.
9. de la Hoz, A., A. Diaz-Ortiz, and A. Moreno, *Microwaves in organic synthesis. Thermal and non-thermal microwave effects*. Chemical Society Reviews, 2005. **34**(2): p. 164-178.
10. Kappe, C.O., *Controlled microwave heating in modern organic synthesis*. Angewandte Chemie International Edition, 2004. **43**(46): p. 6250-6284.
11. Kitchen, H.J., et al., *Modern microwave methods in solid-state inorganic materials chemistry: from fundamentals to manufacturing*. Chem. Rev, 2014. **114**(2): p. 1170-1206.
12. Wiesbrock, F., R. Hoogenboom, and U.S. Schubert, *Microwave-assisted polymer synthesis: state-of-the-art and future perspectives*. Macromolecular Rapid Communications, 2004. **25**(20): p. 1739-1764.
13. Sinnwell, S. and H. Ritter, *Recent advances in microwave-assisted polymer synthesis*. Australian Journal of Chemistry, 2007. **60**(10): p. 729-743.
14. Stefanidis, G.D., et al., *A helicopter view of microwave application to chemical processes: reactions, separations, and equipment concepts*. Reviews in Chemical Engineering, 2014. **30**(3): p. 233-259.
15. Hoogenboom, R. and U.S. Schubert, *Microwave-Assisted Polymer Synthesis: Recent Developments in a Rapidly Expanding Field of Research*. Macromolecular Rapid Communications, 2007. **28**(4): p. 368-386.
16. Komorowska-Durka, M., et al., *A concise review on microwave-assisted polycondensation reactions and curing of polycondensation polymers with focus on the effect of process conditions*. Chemical Engineering Journal, 2015. **264**: p. 633-644.
17. Dąbrowska, S., et al., *Current trends in the development of microwave reactors for the synthesis of nanomaterials in laboratories and industries: a review*. Crystals, 2018. **8**(10): p. 379.
18. Wojnarowicz, J., et al., *Effect of microwave radiation power on the size of aggregates of ZnO nps prepared using microwave solvothermal synthesis*. Nanomaterials, 2018. **8**(5): p. 343.
19. Smoleń, D., et al., *Hydroxyapatite nanopowder synthesis with a programmed resorption rate*. Journal of Nanomaterials, 2012. **2012**: p. 7.

20. Kuśnieruk, S., et al., *Influence of hydrothermal synthesis parameters on the properties of hydroxyapatite nanoparticles*. Beilstein journal of nanotechnology, 2016. **7**(1): p. 1586-1601.
21. Robinson, J., et al., *Scale-up and design of a continuous microwave treatment system for the processing of oil-contaminated drill cuttings*. Chemical Engineering Research and Design, 2010. **88**(2): p. 146-154.
22. Buttress, A., et al., *Development and evaluation of a continuous microwave processing system for hydrocarbon removal from solids*. Chemical engineering journal, 2016. **283**: p. 215-222.
23. Lee, C.S., et al., *Enhancing natural product extraction and mass transfer using selective microwave heating*. Chemical Engineering Science, 2016. **149**: p. 97-103.
24. Racoti, A., et al., *Microwave assisted hydro-distillation of essential oils from fresh ginger root (*Zingiber officinale* Roscoe)*. Journal of Essential Oil Research, 2017. **29**(6): p. 471-480.
25. Routray, W. and V. Orsat, *Microwave-assisted extraction of flavonoids: a review*. Food and Bioprocess Technology, 2012. **5**(2): p. 409-424.
26. Furukawa, H., et al., *The chemistry and applications of metal-organic frameworks*. Science, 2013. **341**(6149): p. 1230444.
27. Thomas-Hillman, I., et al., *Realising the environmental benefits of metal-organic frameworks: recent advances in microwave synthesis*. Journal of Materials Chemistry A, 2018. **6**(25): p. 11564-11581.
28. Nguyen, N.T., et al., *Understanding the acceleration in the ring-opening of lactones delivered by microwave heating*. Tetrahedron, 2014. **70**(4): p. 996-1003.
29. Nguyen, N.T., et al., *Facile one-spot synthesis of highly branched polycaprolactone*. Polymer Chemistry, 2014. **5**(8): p. 2997-3008.
30. Horikoshi, S., et al., *Microwave Chemical and Materials Processing*. 2018: Springer.
31. Committee, I.E. and I. CISPR11, *Industrial, scientific and medical (ISM) radio-frequency equipment-electromagnetic disturbance characteristics-limits and methods of measurement*. Consolidated, Consolidated Edition, 2003. **4**.
32. Zimmerman, W.B., *Multiphysics modeling with finite element methods*. Vol. 18. 2006: World Scientific Publishing Company.
33. Katrib, J., et al., *Improving the design of industrial microwave processing systems through prediction of the dielectric properties of complex multi-layered materials*. Journal of materials science, 2015. **50**(23): p. 7591-7599.
34. Metaxas, A.a. and R.J. Meredith, *Industrial microwave heating*. 1983: IET.
35. Hunt, B.J. and M.I. James, *Polymer characterisation*. 2012: Springer Science & Business Media.
36. Ravve, A., *Principles of polymer chemistry*. 2013: Springer Science & Business Media.

Dr. Adam Buttriss
Advanced Materials Research Group
University of Nottingham

Highlights

- A hybrid microwave reactor producing up to 4.1 kg of polyester resin is reported
- Increase in reaction rate of 265% compared the conventional (oil heated) synthesis
- Higher final product molecular weight (2,100g/mol vs 1,200g/mol) also achieved

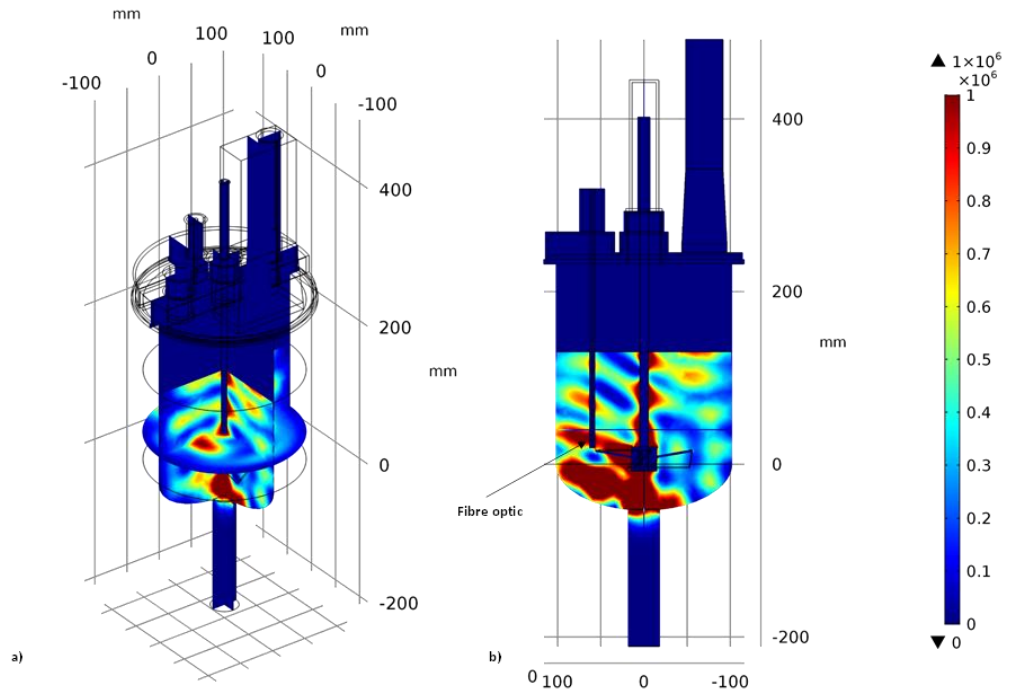
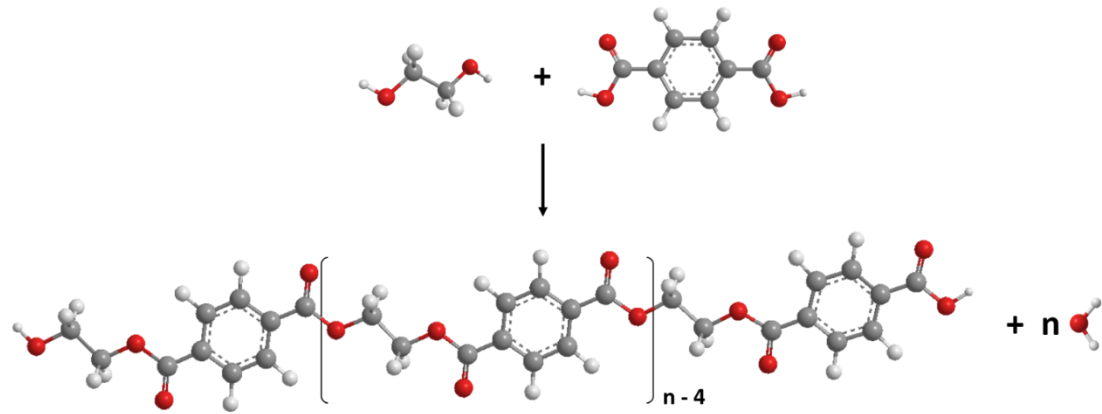

- **Microwave reactor for multi-kilo polyester synthesis**
- **Accelerated reaction rate >265%**
- **Enhanced process control**

Declaration of interests

The authors declare that they have no known competing financial interests or personal relationships that could have appeared to influence the work reported in this paper.

The authors declare the following financial interests/personal relationships which may be considered as potential competing interests:

Signed

Dr. Adam Buttress



12th November 2018