

Srikanth Kavuri

PERFORMANCE ASSESSMENT OF NARROWBAND IOT FOR INTELLIGENT CARGO TRANSPORTATION

Faculty of Computing and Electrical Engineering
Master of Science Thesis
February 2019

ABSTRACT

SRIKANTH KAVURI: Performance Assessment of Narrowband IoT for Intelligent Cargo Transportation

Tampere University

Master of Science thesis, 55 pages

February 2019

Master's Degree Programme in Information Technology

Major: Communication Systems and Networks

Supervisors: Dr. Dmitri Moltchanov, Asst. Prof. Sergey Andreev

Examiners: Dr. Dmitri Moltchanov, Asst. Prof. Sergey Andreev

Keywords: NB-IoT performance, LTE narrow band, cargo ships, smart transportation

Narrow Band Internet of Things (NB-IoT) is the most advanced technology standard for short message services, such as sensor data, developed by 3GPP Release 13 and beyond. The NB-IoT is deployed over Long Term Evolution (LTE) Advanced Pro infrastructure and theoretically, it offers extended coverage up to 40 km from the base station. The objective of this thesis is to analyze the performance of NB-IoT technology in cargo shipment tracking using LTE cellular networks across the coastal line. Currently, about fifty thousand cargo ships use onboard Satellite communication system for all sorts of information exchange with the onshore data centers. The Satellite communication will continue to exist, even after deployment of NB-IoT.

Apart from the machine critical data of the cargo ships, the non-emergency periodic short messages for polling meteorological and container metadata such as temperature, humidity, gaseous detection, etc. will be crucial for the quality of the shipment and the traceability. In this thesis, we analyze deployment of NB-IoT sensors for cargo container to track and provide metadata about the condition of goods. We evaluate three implementation methods of NB-IoT for cargo ships, optimize the coverage and enhance the battery life of the sensor equipment. The main idea is to offload non-critical information that would otherwise use expensive Satellite links, thus embrace the NB-IoT technology at offshore and reduce the financial stress on the cargo shipments.

In the first method, all the sensors transfer the periodic data directly to the coastal LTE network when the ships sail in close proximity to the shore. In the second method, the sensors transfer data to an LTE base station installed locally on the ship and then accumulated information will be relayed to onshore LTE network over NB-IoT channel. In the third method, an Unmanned Aerial Vehicle (UAV/ Drone) base station will collect the data from the onboard sensors; it then relays the information to the onshore LTE network. For all methods, when there is no LTE coverage, the accumulated data will be sent over the Satellite link, which will be available onboard.

The assessment confirms the hypothesis that the packet loss probability reduces when the base station is located close to the sensor, where the number of retransmissions will be reduced, and more uplink resources will be available. For direct access scenario, a large number of users contend for Random Access Channel (RACH) simultaneously after entering into the LTE coverage. The packet will be dropped after reaching the maximum number of attempts for the RACH resources. As per the simulated results, mean lifespan of a sensor is greatly affected by the LTE network availability and random access procedure, during which the sensor spends most of the energy for transmissions. The mean transmit delay will be higher with second and third methods where the ship BS, UAV BS accumulate packets until they find the LTE network or relays the data to the Satellite link if the LTE outage is longer. This performance assessment provides technical insights for the maritime industry to embrace the NB-IoT for tracking and condition monitoring of shipment.

PREFACE

Firstly, I would like to thank Dr. Dmitri Moltchanov for mentoring and guiding me with the topic and motivating throughout the thesis work. It was helpful to receive timely feedback on my work and providing a roadmap. It was a great experience working for this thesis where, I experienced research methodology, materializing the basic idea into a scientific work.

I must thank Tampere University administration for providing me an opportunity and making a hassle-free ecosystem for the internationals. Also thankful for the entire faculty and co-students helped me in enriching my knowledge and cooperated for the term that I spent on the Master's degree.

I consider this is one of the milestones achieved in the journey of life and would dedicate this achievement to my family, who sacrificed and supported me no matter what may come.

Tampere, 17 February 2019

Srikanth Kavuri

CONTENTS

1. INTRODUCTION	1
1.1 Massive Machine Type Communication	2
1.2 Smart Applications of NB-IoT Technology	5
1.3 Use Case for Autonomous Vessels	7
1.4 State of the Art of Internet of Things technology	8
2. NB-IOT TECHNOLOGY AND EVOLUTION	10
2.1 NB-IoT Specification and Deployment Options	11
2.2 NB-IoT Frame Structure	12
2.3 Coverage Assessment	21
2.4 Energy Consumption	23
3. NB-IOT FOR CARGO SHIPS	26
3.1 Deployment options	26
3.1.1 Direct Access with Coastal LTE Network	26
3.1.2 Interface with Ship Base Station	28
3.1.3 Interface with Unmanned Aerial Vehicle Base Station	31
3.1.4 Backup Plan during LTE Network Outage	32
3.2 System Model	33
3.3 Connectivity Assessment	34
3.4 Simulation Model for RACH	35
4. NUMERICAL ASSESSMENT	42
4.1 System input parameters	42
4.2 Packet loss performance analysis	43
4.3 Mean transmit delay analysis	46
4.4 Mean sensor lifespan analysis	48
5. CONCLUSION	51
REFERENCES	53

LIST OF FIGURES

Figure 1.	<i>M2M traffic growth [9].</i>	3
Figure 2.	<i>NB-IoT applications [7].</i>	5
Figure 3.	<i>LTE based IoT technologies [7].</i>	10
Figure 4.	<i>NB-IoT deployment options [14].</i>	11
Figure 5.	<i>LTE Narrowband Downlink frame structure [35].</i>	12
Figure 6.	<i>NB-IoT Primary Resource Block</i>	13
Figure 7.	<i>Narrowband Control Channel Elements format</i>	16
Figure 8.	<i>NB-IoT Uplink frame format.</i>	16
Figure 9.	<i>LTE NB Preamble format</i>	18
Figure 10.	<i>NB-IoT Random Access Procedure</i>	19
Figure 11.	<i>NPRACH Preamble Repetitions.</i>	20
Figure 12.	<i>NB-IoT Downlink coverage.</i>	22
Figure 13.	<i>NB-IoT Uplink coverage</i>	23
Figure 14.	<i>Power Saving Mode [37].</i>	24
Figure 15.	<i>extended Discontinuous Reception mode [37].</i>	25
Figure 16.	<i>Direct interface with onshore LTE network</i>	26
Figure 17.	<i>Radio LOS and horizon distances (option 1)</i>	27
Figure 18.	<i>Interface with ship mounted base station</i>	29
Figure 19.	<i>Radio LOS and horizon distances (option 2)</i>	29
Figure 20.	<i>Using mobile IoT base station using UAV.</i>	31
Figure 21.	<i>Radio LOS and horizon distances (option 3)</i>	32
Figure 22.	<i>Backup network during LTE network Outage.</i>	33
Figure 23.	<i>Connectivity model for direct access.</i>	34
Figure 24.	<i>Connectivity model for UAV Base station</i>	35
Figure 25.	<i>Poisson Process.</i>	37
Figure 26.	<i>Poisson superposition process.</i>	37
Figure 27.	<i>Queuing mechanism at relaying point.</i>	38
Figure 28.	<i>Direct access implementation</i>	41
Figure 29.	<i>Ship BS and UAV implementation.</i>	41
Figure 30.	<i>Packet losses over the offered load</i>	43
Figure 31.	<i>Packet loss probability as a function of offered traffic load</i>	45
Figure 32.	<i>Packet loss probability as a function of BS intensity</i>	45
Figure 33.	<i>Packet loss probability as a function of preamble attempts</i>	46
Figure 34.	<i>Mean delay as a function of offered traffic load</i>	47
Figure 35.	<i>Mean delay as a function of BS intensity</i>	47
Figure 36.	<i>Mean delay as a function of preamble attempts</i>	48
Figure 37.	<i>Mean sensor lifetime as a function of offered traffic load.</i>	49
Figure 38.	<i>Mean sensor lifetime as a function of BS intensity.</i>	49
Figure 39.	<i>Mean sensor lifetime as a function of preamble attempts.</i>	50

LIST OF TABLES

Table 1.	<i>Comparison of IoT technologies</i>	5
Table 2.	<i>LTE PRB indices for cell connection in in-band operation [13]</i>	12
Table 3.	<i>NPDSCH carrying SIB1-NB [3]</i>	14
Table 4.	<i>MIB parameters</i>	15
Table 5.	<i>TBS for NPDSCH carrying SIB1-NB</i>	15
Table 6.	<i>SIB2 parameters for RACH</i>	16
Table 7.	<i>Downlink Control Indicator Formats</i>	17
Table 8.	<i>Uplink resource allocation</i>	17
Table 9.	<i>Scheduling delay (Format N1)</i>	16
Table 10.	<i>Subframe allocation for NPDSCH</i>	16
Table 11.	<i>Uplink resource unit combinations</i>	17
Table 12.	<i>NPRACH parameters</i>	18
Table 13.	<i>LTE Narrowband Preamble types</i>	19
Table 14.	<i>Downlink power budget for NB-IoT</i>	21
Table 15.	<i>Uplink power budget for NB-IoT</i>	22
Table 16.	<i>eDRX cycle length comparison</i>	25
Table 17.	<i>System parameters</i>	33
Table 18.	<i>class Coverage parameters</i>	38
Table 19.	<i>class Energy parameters</i>	39
Table 20.	<i>class Node parameters</i>	39
Table 21.	<i>class Rach parameters</i>	40
Table 22.	<i>System input parameters summary</i>	42

LIST OF SYMBOLS AND ABBREVIATIONS

dB	Decibels
CP	Cyclic Prefix
DRX	Discontinuous Reception
EARFCN	Evolved-UTRA Absolute Radio Frequency Number
GHz	Giga Hertz
GSM	Global System for Mobile
HD-FDD	Half Duplexing-Frequency Division Duplexing
IoT	Internet of Things
LPWAN	Low Power Wide Area Networks
LOS	Line Of Sight
LTE	Long Term Evolution
MAC	Media Access Control
MCL	Maximum Coupling Loss
MIB	Master Information Block
NB-IoT	Narrowband IoT
NF	Noise Factor
NPBCH	Narrowband Physical Broadcast Channel
NPDCCH	Narrowband Physical Downlink Control Channel
NPDSCH	Narrowband Physical Downlink Shared Channel
NPRACH	Narrowband Physical Random Access Channel
NPSS	Narrowband Primary Synchronization Signal
NPUSCH	Narrowband Physical Uplink Shared Channel
NRS	Narrowband Reference Signal
NSSS	Narrowband Secondary Synchronization Signal
OFDMA	Orthogonal Frequency Division Multiple Access
PHY	Physical Layer
PLMN	Public Land Mobile Network
PRB	Primary Resource Block
PSM	Power Saving Mode
QAM	Quadrature Amplitude Modulation
QPSK	Quadrature Phase Shift Keying
RAR	Random Access Response
RNTI	Radio Network Temporary Identifier
RRC	Radio Resource Controller
SC-FDMA	Single Carrier FDMA

SF	Sub Frame
SFN	Super Frame Number
SIB	System Information Block
SNR	Signal to Noise Ratio
TA	Tracking Area
TBS	Transport Block Size
UAV	Unmanned Aerial Vehicle
UE	User Equipment
3GPP	3rd Generation Partnership Project

h	hour
kbps	kilo Bits Per Second
kHz	kilo Hertz
km	kilo meter
km/h	kilometer per hour
m	meter
ms	milli seconds
MHz	megahertz

1. INTRODUCTION

In this chapter, the objective of the thesis and the current state-of-the-art technologies for Massive Machine Type Communication (mMTC) are detailed. The focus is to describe various applications of IoT, the use case for the marine industry and the IoT offerings to enhance the profitability and automate the cargo shipment industry.

For the smart supply chain management, smart cities, smart factory, and autonomous vehicular transportation, use of IoT technologies to optimize the service times and improve efficiency. Shipment tracking is one of the key factors for the cross border trading and an opportunity to embrace the IoT technology. Goods are transported by rail/ road, cargo ships. Some of the goods, such as pharmaceuticals, vegetables, and semiconductors, need extreme safety and good preservation procedures in place. Monitoring of the leakages, gases, moisture, temperature, etc. are required while the cargo is on its way.

An average cargo ship carries more than two thousand containers [36] that need a lot of crews to inspect each container periodically to avoid any wastage/ contamination. In that context, it is necessary to proactively track the goods health and report to the on-shore server farm/ data center timely to enact. In this thesis, we assess different NB-IoT implementations for cargo ships to track containers condition and its traceability. It also enables the e-commerce giants to estimate and optimize the delivery time and automate loading and unloading the goods at the designated ports. The sensor device, which works on battery power, polls metadata periodically to the gateway.

The NB-IoT compliant sensor device can work as long as 10 years with battery power (assuming the tiny packet dissemination for a given interval). The smart sensors, which collect metadata from the containers on the cargo ship, will alert the shipping companies for necessary action on time. The current state of the art technology for any offshore communication is limited to the Satellite communication system. Offloading some of the sensor data from Satellite link to the coastal LTE network while the ship sails across the coastal line will drastically reduce the expense on the communication system.

The NB-IoT offers extended coverage, longer battery life, and relatively improved throughput compared to that of other LPWAN technologies. Since NB-IoT is cellular

based networking protocol, it offers enhanced security and authentication mechanism. Although in a static scenario, the NB-IoT technology supports up to 52574 end devices per cell sector [2], in this thesis, we assumed the scenario where the sensors will be moving which causes a sudden spike in the number of end devices attempting to access the channel on the base station. When multiple cargo ships, those containing thousands of IoT sensors, pass through the same base station, it is almost impossible for the base station to provide uplink resources, packet loss as a result.

1.1 Massive Machine Type Communication

The industry body ITU has characterized the 5G network as enhanced Mobile Broadband (eMBB), Ultra reliable low-latency communications (URLLC), and mMTC. The NB-IoT/ mMTC are outlined in 3GPP Release 15 and 16. The 5G Alliance endorses 5G mobile networks for factory automation and process industry.

The Machine type communication (MTC) is the latest advancement in industrial communication. The 3GPP has initially specified MTC under LTE-M deployment, in Release 12, 13 and 14, further classified as Cat 0, Cat M1, Cat M2, non-BL. The mMTC provides a platform to the instrumentation, processing equipment, sensors to communicate via wired or wireless channels. It aims to improve industrial productivity and efficiency, thus increasing the factory output and open opportunity for new business models. In the context of industry 4.0, mMTC will assist to fully automate the control systems, extract metadata, process it and upload to the cloud.

The digitization of the factory and fully autonomous production will be backed by the mMTC in the near future. In the context of smart cities, every metering device, safety and surveillance equipment, environmental monitoring sensors will communicate with the cloud without human-in-loop using LPWAN technologies. In contrast to the eMBB, the primary function of mMTC is to collect and process a massive number of small data packets over a given interval, compromised with the available data rate and the latency.

As per the Cisco's M2M traffic forecast, the number of connected devices will be doubled by 2022 while the traffic volume will be quadrupled during the same time. New technologies to evolve to meet the demand from the industry still cost less and sustain for long operation. It is also important to have a unified infrastructure to cater to various applications.

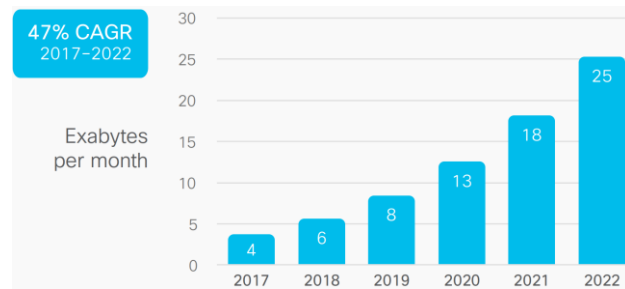

Figure 1. M2M traffic growth [9].

NB-IoT: The 3GPP body has originally defined NB-IoT standard under Release 13 and 14 based on LTE network Cat NB1 and Cat NB2. The NB-IoT is specially designed to provide deep coverage in indoors, low power consumption, highly dense deployment, need of just 200 kHz bandwidth for one Primary Resource Block (PRB). It uses SC-FDMA modulation for uplink and OFDM for downlink communication. It can be flexibly deployed in LTE, 5G and GSM bands as well, also deployable alongside the existing LTE carrier or make use of guard bands. Theoretically, NB-IoT offers up to 40 km coverage using Cyclic Prefix (CP) Format 1 and about 8 km using CP Format 0 [35]. However, the data rate depends on the load on the base station and the density of sensors within a cell site.

The NB-IoT is primarily designed for machine type communication that requires small bursts but many transmissions. The coverage offered by NB-IoT is significantly larger compared to that of other LPWAN technologies. It fully suits for metering, monitoring of the environment, equipment and also human health condition, tracking, etc. which does not guarantee the low latency communication, but still works as best effort based. It offers improved security and integrity to the user data as it is deployed over cellular infrastructure, which is equipped with encryption, authentication of user data. Since NB-IoT uses licensed spectrum, less interference from the other devices operating in same spectrum.

EC-GSM-IoT: Extended coverage GSM IoT is another cellular based LPWAN technology that co-exists with 2G, 3G, and 4G mobile networks. It supports backward compatibility with the existing GSM infrastructure. Due to the usage of the low carrier frequency, it provides improved coverage and low complexity echo system. The 3GPP body has confirmed the EC-GSM-IoT specification in Release 13. It is deployed in In-band GSM band, works with GMSK and 8 PSK modulation schemes, supports 33 dBm, 23 dBm transmit power classes. Due to the low transmit power; the sensor lifetime will be 10 years and the end device work in PSM or eDRX modes. The main applications are short messages, IoT packets, and voice.

LTE-M: The LTE-M technology was specified by 3GPP Release 13. It uses 1.4 MHz bandwidth and allows IoT devices to directly connect to the 4G network with coverage > 156 dB Maximum Coupling Loss (MCL). IoT devices can feature either Power Saving Mode (PSM) or extended Discontinuous reception (eDRX) mode. It uses OFDMA, 16 QAM in downlink and SC-FDMA, 16 QAM modulation schemes in up-link. LTE-M suits for the less dense sensor applications where no additional infrastructure is feasible to deploy such as gateways. LTE-M has edge over other technologies when it comes to the low-latency; also, the data rate is quite promising. The main applications are smart metering, smart homes, asset tracking.

LoRaWAN: Long Range WAN is a non-cellular LPWAN technology designed for IoT applications. It uses LoRa or FSK modulation schemes and deployed in industrial, scientific and medical (ISM) radio bands 2.4 GHz and 5 GHz. The frequency usage can be different for different countries. It uses chirp spread spectrum (CSS) that makes it robust while handling the noise and fading. The LoRa end devices always connect to the local gateways, which then relay the data to the central servers. Due to its heavy dependence on the gateway and the usage of ISM band, the end devices might experience interference from the other devices within the ISM frequencies. The IoT devices are classified into three categories in LoRa, i.e. Class A, Class B, and Class C. LoRa features multicasting that suits for mass message distribution.

SigFox: It is another non-cellular LPWAN technology that provides long-range IoT coverage, it uses conventional radio propagation using BPSK. It works in sub-GHz ISM band, uses ultra-narrow band channels (UNB), which suits for the MTC traffic. It uses DBPSK, GFSK modulation schemes for uplink and downlink. The end device can transmit 140 messages per day of payload size of 12 bytes. It does not feature data encryption. As SigFox offers up to 100 bits/sec data rate, it is suitable for small datagram applications. It can also be noted that the bandwidth is quite low and low radiating frequency, thus the longer communication range as a result. The main applications are pet, device tracking, monitoring the environmental conditions, industry utilities monitoring.

The following Table 1 describes the principle differences among different IoT technologies.

Table 1. Comparison of IoT technologies

	NB-IoT	EC-GSM-IoT	LTE-M	LoRa	SigFox
Bandwidth	200 kHz	200 kHz	1.4 MHz	125 kHz	100 Hz
MCL	164 dB	164 dB	156 dB	155 dB	160 dB
Data rate	250 kbps	140 kbps	1 Mbps	50 kbps	100 bps
Band	Licensed LTE	Licensed GSM	Licensed LTE	915 MHz	< 1 GHz
Range	15 km	15 km	5 km	15 km	50 km
Power class	23 dBm	33 dBm, 23 dBm	23 dBm, 20 dBm	14 dBm	14 dBm

1.2 Smart Applications of NB-IoT Technology

The primary applications of the Internet of Things are industrial equipment connectivity, home appliances and wearables. Some of those require high throughput and some applications require low latency. Some IoT technologies offer high throughput as detailed in the above section. NB-IoT provides a blend of low latency and average throughput compared to the other LPWAN technologies. Due to the enhanced security and data encryption, it suits for a wide variety of applications as explained in the following.

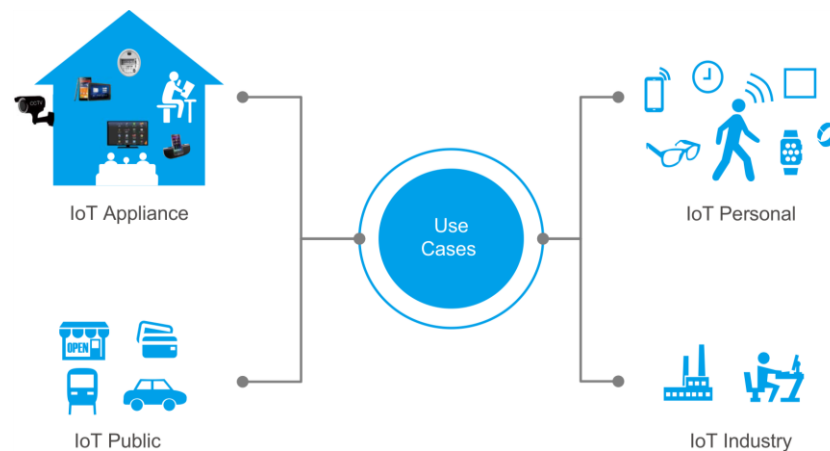
**Figure 2.** NB-IoT applications [7].

Healthcare Industry: At present smart wearables are capable of connecting with the mobile phones, through which the human body metadata (such as temperature, pulse, humidity, etc) periodically and transmit to the cloud for tracking the health. Thus, preventive measures can be taken for any anomaly at the early stage of disease. Enabling NB-IoT technology for the wearables, which lasts for ten years, will be more efficient as it does not depend on the mobile phone as a gateway anymore.

Having NB-IoT enabled implant for the patients, especially those with a disability will do health monitoring round the clock without human intervention. Additionally, the tiny sensors can be attached to the refrigerators, which tracks the condition of medicines, vaccines, etc. for preserving them for a long duration. The NB-IoT sensor is safe for patient monitoring, due to the low radiating power, which does not harm to the human.

Goods transportation: Most of the shipments, especially white goods can be tracked during transportation from the warehouse to the customer location. During the transit, the condition of the item such as any leakages or extreme temperature/ vibration, can be monitored and alert the person in-charge for immediate action. Since most of the countries have good mobile penetration, the tracking of consignment will be hassle-free while IoT sensors poll the data periodically.

For large e-commerce companies, IoT sensors will automate the goods movement and optimize the transit routes for the subsequent orders. Other non-cellular based LPWAN technologies do not support this feature, as their infrastructure is not interoperable. Using this case study, a container can be tracked from the source to destination including the sea cargo shipment using LTE networks infrastructure across the globe.

Smart home/ Utilities: Currently home electronics like TV, air conditioning, refrigerator, washing machine, lights, water pumping etc. are monitored and controlled by a human. By embedding the NB-IoT sensors to these electronics, one can operate them remotely using mobile applications. Due to the advantage of deep penetration inside the house, with low power budget (-164.4 dBm), NB-IoT sensors have edge over other contemporary IoT technologies. As it is deployed over LTE networks and utilizes only 200 kHz channel for each PRB, it offers a massive number of user access at lower costs.

The sensors do not always be in *connect* mode with the base station, they will enter into idle mode until next duty cycle, hence battery life is 10 years long; it ideally suits for all kinds of home automation applications. It suits for the low bandwidth applications, such as smart metering (electricity/ water/ gas), facility management, smart parking, as it supports the coverage up to eight kilometers in dense urban area, even can reach the basement of the house.

Precision farming: The NB-IoT sensors can solve some of the challenges faced by the dairy farmers, where they had to manually check the temperatures, water, and food quality and adjust the environment for improved production and health of the cattle. It is worth to make cattle wearable and monitor their health for preventive and corrective

measures. In addition, their position can be tracked in case they moved away from the dairy farm. In the future, the data can be analyzed and provide an optimized solution to the farming industry for good practices.

When it comes to the agriculture and fishery, NB-IoT assists to digitize and produce meaningful data for optimizing the farming condition. The quality and quantity of water, soil quality testing, and environmental data can be periodically collected and analyzed to improve the farming yield. It can also solve the problem of preservation and reduces possible contamination. The correct preservation procedures can only be derived from the existing data, which is possible with the IoT. The storage and preservation techniques can be fully automated, thus the overall farming income increases with the technology in place.

1.3 Use Case for Autonomous Vessels

The autonomous vessels will be equipped with hundreds of instrumentation equipment, proximity sensors, and situational awareness sensors and carry thousands of containers. Smart containers and intelligent machinery will take over the human job in automated vessels [10], it means a lot of additional space for goods on the ship and less expense for the transportation companies. It is only possible with a robust communication system on board, other than conventional satellite links. The NB-IoT suits for carrying the short payload such as environmental condition data, instrumentation health report, periodic maintenance related information.

Although NB-IoT provides access for the sensor network on the vessel, it needs a gateway to push the sensor data to the cloud via satellite or onshore LTE network. Due to the extended coverage factor, floating NB-IoT base station could offload the data when it discovers the LTE network, especially in the North Sea where most of the Oilrigs had fiber optic connection to the cloud. Conventional Wi-Fi, BLE, legacy 4G networks cannot suffice the need for massively connected devices, as the end devices choke the uplink resources. One LTE NB base station with customized configuration can handle thousands of sensor equipment alongside the voice and broadband services.

Condition monitoring: The main application for the autonomous vessels is to track the container health and itemize the loaded, unloaded goods at designated ports. The NB-IoT supports bidirectional communication that makes it to operate the container remotely through micro controllers, interfacing with the IoT sensor. The sensor lifespan is quite long, that will reduce the maintenance and the cost for the massive deployment, yet the

same sensor connects seamlessly with inland LTE network. NB-IoT supports encryption, authentication, and differential services, ensures the safety and quality of the trade at offshore. It provides safe communication that can defend from the pirates and hackers.

Intelligent machines: All the instrumentation, metering equipment onboard can reliably use NB-IoT to relay the data to the cloud. It helps to proactively identify the faults of the equipment and action before any interruption. It is possible to control some of the instrumentation equipment remotely through NB-IoT interface, where they are susceptible for latency. The onboard machines need to poll data periodically and on-demand basis, there is no limit on the amount of data and the frequency of transmission, NB-IoT has edge over other protocol in this requirement as the offered data rate can be up to 250 kbps and any number transmissions as long as the load is optimal.

Localized services: The IoT devices will collect some of the critical information from SA sensors in and around the ship and relay to the local server onboard, which will perform data analytics locally to take certain action. It reduces the need for additional infrastructure on ships and unifies the mode of communication. Since the movement of the vessel is relatively slow and there exist systems on board to detect the objects at far distances, the response time need not be in microseconds for the vessel operation. In that context, the NB-IoT offers extended connectivity for the massive sensors devices. However, the latency will not be hours, but limited few seconds considering good throughput.

1.4 State of the Art of Internet of Things technology

The existing LPWAN technologies are SigFox, LoRa, Weightless SIG, nWave, Dash7, LTE Cat-M, and NB-IoT. Firstly, non-cellular technologies are meant to work in ISM bands, which causes a lot of interference from other devices. Those IoT devices, form a star topology, requires a gateway to relay the data to the cloud. Secondly, cellular-based IoT technology provides end-to-end payload authentication, encryption, which are not robust within ISM band implementation. Thirdly, LTE NB-IoT, LTE-M are globally approved by 3GPP body, hence no proprietary, copyright against the use of this technology while others were protected by their alliances.

Due to the globally unique framework for cellular-based IoT technologies, it is easy to deploy and utilize roaming, interoperable features among different operators in different regions. The non-cellular based LPWAN technologies require a dedicated infrastructure to function, while NB-IoT co-exists with LTE, 5G networks, less capital investment as a

result. NB-IoT is an integral part of LTE Advanced Pro, 3GPP Release 13. At present, most of the telecommunication service providers have already deployed LTE Advanced Pro. Adding additional carriers within the cell site will instantaneously scales up to thousands of connected devices.

The NB-IoT is designed to connect a massive amount of devices, allowing the payload of 1600 Bytes. It supports small data granularity and deep penetration to the indoors, and basement devices. Compared to the contemporary IoT technologies, NB-IoT offers extended coverage and less resource hungry. When the sensors are mobile, a lot of resources will be consumed for retransmissions and repetitions. The same NB-IoT sensors can work very well while the containers transit through rail/ road transportation providing end-to-end tracking mechanism per container.

When a cargo ship is fitted with thousands of sensors, which attempts to access the nearby base station simultaneously, due to the sudden spike in traffic, the packet loss will be high. It also affects the battery life of the sensors that have to be efficient for deployment. We will analyze the performance metrics; packet loss, sensor lifespan, base station density and mean transmit delay. We will then evaluate the options for improving the coverage via direct access, relaying base station on ship, UAV base station onboard. By implementing the NB-IoT sensors, the supply chain inventories can be very well optimized through big data analytics.

This thesis is organized as follows:

- Introduction briefs the main idea of this thesis and its organization.
- NB-IoT technology and evolution details the specification, scheduling and coverage analysis, and energy consumption details.
- NB-IoT for cargo ships describes the deployment models, their pros and cons, system modeling, connectivity assessment and the brief description of the simulation model.
- Numerical assessment explains NB-IoT resources evaluation, performance metrics.
- The conclusion provides overall insights into NB-IoT solution for the offshore environment.

2. NB-IOT TECHNOLOGY AND EVOLUTION

In this chapter, the NB-IoT technology evolution is detailed. The NB-IoT specification and various deployment options, the frame structure are elaborated. The coverage assessment for the use of cargo ships and its energy consumption for different modes are explained.

The 3GPP standardized NB-IoT technology under Release 13. It is cellular based LPWAN technology. As NB-IoT is an open standard, the end device will work in different operator networks and spectra. It supports both IP and non-IP data traffic and needs minimal signaling over the radio interface. NB-IoT's access network remains the same as the legacy LTE network. The main difference is that NB-IoT node will always contend for the uplink channel and then establish the session, while the end device will be in *connect* mode in legacy LTE. The NB-IoT does not support handover, but the end device needs to establish session every transmission.

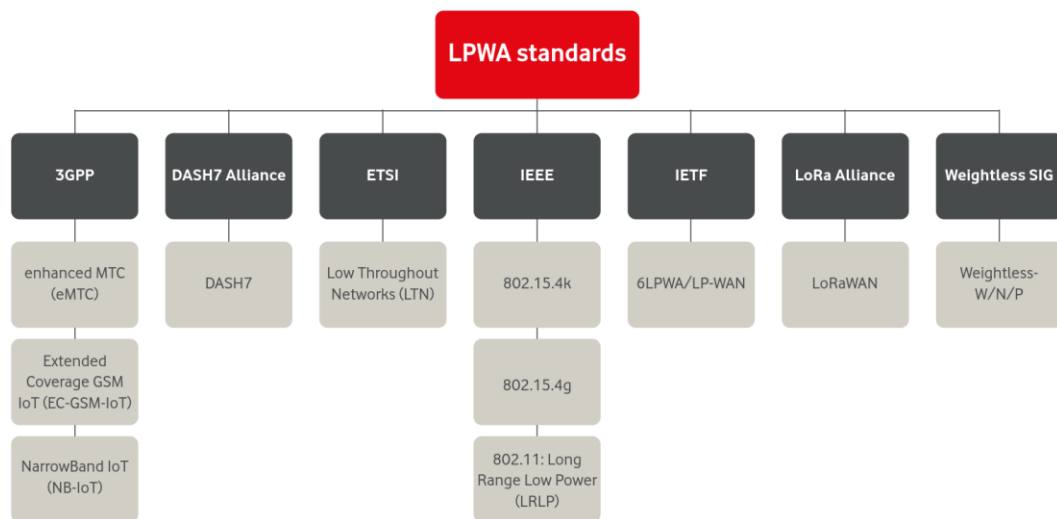

Figure 3. LTE based IoT technologies [7].

The NB-IoT solution does not suit for delay sensitive applications due to high latency and duty cycle, it also not suits for bandwidth and power-hungry applications like streaming, audio/video file transfers, mesh-type signaling. The global cellular network penetration is greatly improved today and shaping towards handling machine type communication. In the context of industry 4.0, there will be millions of factory equipment, which will connect to the IoT platform for proactive maintenance and data analytics.

Since NB-IoT does not collaborate with other radios, it will only not support all other LTE Advanced network features. Cellular-based IoT solution provides enhanced secured, scalable and reliable service compared the other IoT technologies. The initial random access procedure for LTE NB is slightly different compared to that of legacy LTE, which got simpler. It will be detailed in the following section.

2.1 NB-IoT Specification and Deployment Options

The NB-IoT works in Half Duplex (HD) mode and Frequency Division Duplexing (FDD), the uplink and downlink transmissions use different frequency resources. The UL and DL transmissions are separated by at least one subframe for switching between transmit and receive function. It will support on either LTE band or GSM band. It has the following advantages: reusing GSM spectrum, deep signal penetration, cheap chipset design, and power efficiency as long as 10 years of battery life using PSM and DRX modes, improved security procedures, scalability. The main purpose of it is to handle the short messages but less frequent and hundreds of sensors within the cell site.

Conventional IoT technologies need dedicated infrastructure, while NB-IoT will be implemented over LTE-M2 (LTE Advanced Pro) cellular networks. Due to the narrowband carrier design and SC-OFDM in the uplink transmission, resource utilization is more flexible. The MCL offered by NB-IoT technology is 164 dB in both uplink and downlink, comparatively improved MCL than all other LPWAN technologies. The 3GPP has defined the following frequency bands for NB-IoT deployment: 1, 2, 3, 5, 8, 11, 12, 13, 17, 18, 19, 20, 25, 26, 28, 31, 66, and 70. The NB-IoT's PRB has 180 kHz bandwidth that is channelized into 12 subcarriers of 15 kHz tone spacing using OFDMA.

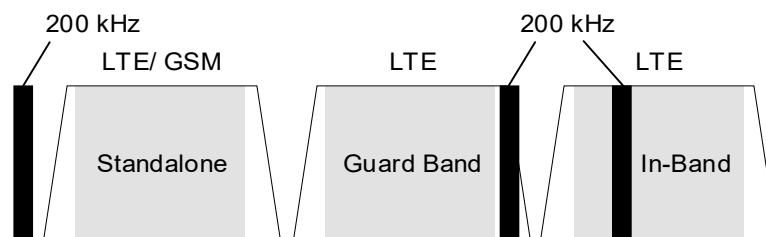

Figure 4. NB-IoT deployment options [14]

The uplink channel uses SC-FDMA to provide both single tone (3.75 kHz or 15 kHz) and multi tone (3.75 kHz and 15 kHz). As illustrated in Figure 4, in Standalone mode, the NB-IoT will re-use the available bandwidth in both GSM and LTE spectrums. In Guard band mode, it utilizes the guard band of the LTE spectrum as for NB-IoT PRB. While in in-band mode, it will utilize one of the LTE carrier resource blocks. The below Table 2

shows the supported indices in LTE in-band operation, 1.4 MHz bandwidth is not supported due to the resource clash between LTE and NB-IoT. In contrast to the legacy LTE, the NB-IoT has three coverage enhancement levels, i.e CE0, CE1, and CE2 where CE2 refers to the poor coverage area.

Table 2. LTE PRB indices for cell connection in in-band operation [13]

LTE system bandwidth	3 MHz	5 MHz	10 MHz	15 MHz	20 MHz
LTE PRB indices for NB-IoT synchronization	2, 12	2, 7, 17, 22	4, 9, 14, 19, 30, 35, 40, 45	2, 7, 12, 17, 22, 27, 32, 42, 47, 52, 57, 62, 67, 72	4, 9, 14, 19, 24, 29, 34, 39, 44, 55, 60, 65, 70, 75, 80, 85, 90, 95

2.2 NB-IoT Frame Structure

Downlink Scheduling

The downlink scheduling is similar to the legacy LTE network. Only one session is permitted and uses two antennas for TX diversity. The NB-IoT has the following physical channels: NB Physical Broadcast Channel (NPBCH), NB Physical Downlink Shared Channel (NPDSCH), Narrowband Physical Downlink Control Channel (NPDCCH), NB Primary Synchronization Signal (NPSS), NB Physical Secondary Synchronization Signal (NSSS)

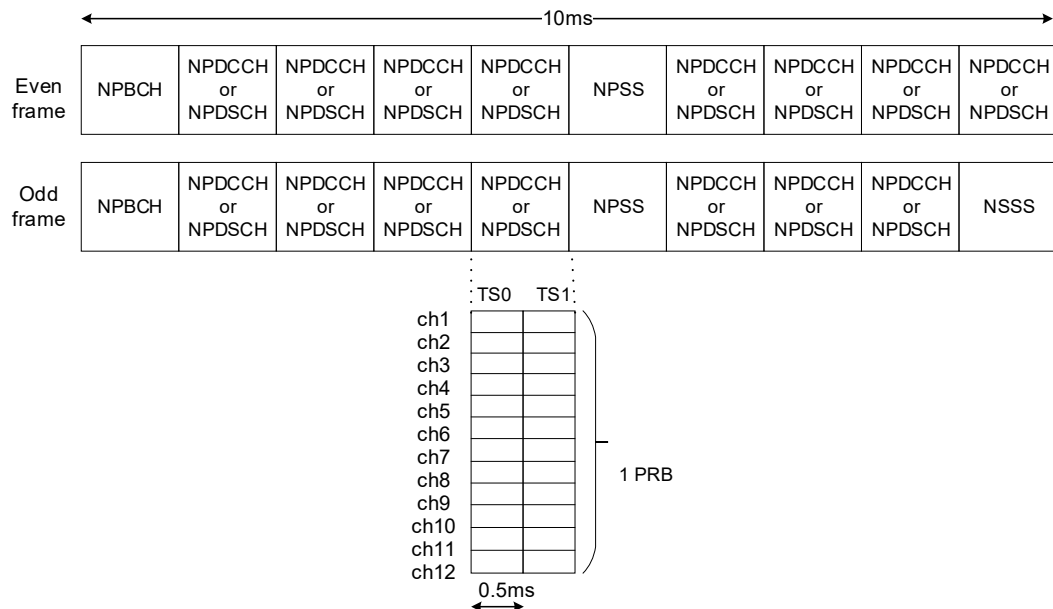

Figure 5. LTE Narrowband Downlink frame structure [35]

Primary Resource Block

The NB-IoT is an integral part of LTE Advanced Pro network, one of the LTE resource block 180 kHz is dedicated for the NB-IoT. In the context of NB-IoT PRB is 180 kHz which is then divided into 12 subcarriers. Each carrier will be split into two subframes. Each subframe accommodates 7 OFDMA symbols, and use QPSK modulation. LTE NB-IoT frame structure for downlink channel is similar to that of legacy LTE with few parameters introduced to cope with the IoT requirements. Each radio frame is 10 ms that comprises 10 subframes of 1 ms each as illustrated in Figure 5.

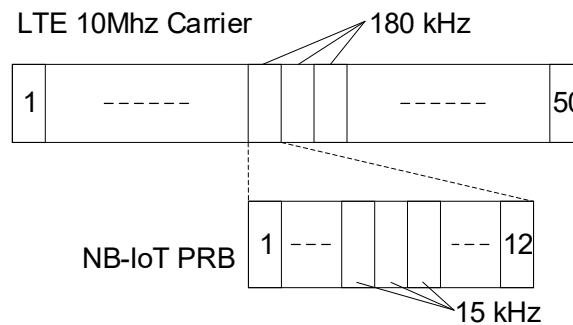

Figure 6. NB-IoT Primary Resource Block

The Narrowband reference signal (NRS) assists the end device for channel estimation and helps for the Tx diversity.

Narrowband Primary Synchronous Signal (NPSS)

The NPSS provides the synchronization in both time and frequency in the preliminary channel acquisition. Unlike legacy LTE that contains three primary synchronization signals, the NB-IoT has one NPSS for all cells which simplifies the detection process. The NPSS will be broadcasted for every 10 ms and it will be transmitted on subframe 5 of every downlink radio frame. In the initial transmissions, the end device will be unaware of the deployment mode and use of the subframe for LTE traffic. To avoid the collision with the LTE subframes, there will be a secondary synchronization signal that will be transmitted on subframe 9. The NPSS uses Zadoff-Chu signal as the following form (3GPP TS36.211-10.2.7.1):

$$d_l(n) = S(l) \cdot e^{-j(\pi u n(n+1)/11)}, \quad n = 0, 1, \dots, 10, \quad (1)$$

where the Zadoff-Chu root sequence index $u = 5$ and $S(l)$ for different symbol indices l is given by following table.

Cyclic prefix length	$S(3), \dots, S(13)$										
Normal	1	1	1	1	-1	-1	1	1	1	-1	1

Narrowband Secondary Synchronous Signal (NSSS)

The NSSS will determine the cell ID and further information about the frame structure. There are 504 cell IDs that are unique and valid physical IDs. Unlike legacy LTE's SSS whose periodicity is 5 ms, the NB-IoT NSS is transmitted on the 10th subframe, with a periodicity of 20 ms and sequence repetition will be 80 ms periodicity. Narrowband secondary synchronization signal comprises 132 number sequence that uses m-sequence as mentioned in the following:

$$d(n) = b_q(m)e^{-j2\pi\theta_f n} e^{-j\pi u n'(n'+1)/131}, \quad (2)$$

where $n = 0, 1, \dots, 131$,

$$n' = n * \text{mod}(131),$$

$$m = n * \text{mod}(128),$$

$$u = N_{ID}^{N_{cell}} \text{mod}(126) + 3,$$

$$q = \lfloor N_{ID}^{N_{cell}} / 126 \rfloor,$$

The binary sequence $b_q(m)$ is given by Table 10.2.7.2.1-1 (3GPP TS36.211). The cyclic shift θ_f in frame number n_f .

Narrowband Physical Broadcast Channel (NPBCH)

The Narrowband Physical Broadcast Channel carry the physical characteristics of the system which is called Master Information Block (MIB). It has a combination of eight blocks of 80 ms resource blocks. To avoid the clash with LTE signaling channels, NPBCH will not be transmitted in initial three symbols. Its periodicity is 640 ms. It carries 34 bits of information as described in the following.

Master Information Block

MIB carries the system information to get SIB1. The SIB1 comprises the system information to attain other SIBs. The MIB has periodicity as 640 ms, it carries the critical information for the end devices in the initial phase of the connection establishment with the LTE network. The initial transmission will be started on subframe 0 and then repetitions will occur on subframe 0 of all other radio frames. The MIB information is sent over 8 independent decodable blocks having 80 ms span.

Table 3. NPDSCH carrying SIB1-NB [3]

<i>schedulingInfoSIB1-r13</i>	Number of NPDSCH repetitions
0, 3, 6, 9	4
1, 4, 7, 10	8
2, 5, 8, 11	16
12-15	Reserved

The number of NPDSCH repetitions will be decided based on incoming SIB1 information from the base station (Table 3). The physical layer data size for the corresponding upper layer information is referred to Transport Block Size (TBS). The below Table 5 describes the transport block size for the I_{TBS} index number provided in SIB1.

Table 4. MIB parameters

Parameter	Description
<i>systemFrameNumber-MSB (4 bits)</i>	This parameter determines the system timing.
<i>hyperSFN-LSB (2 bits)</i>	A group of 1024 radio frames is one hyper frame. This number helps to estimate the timing.
<i>schedulingInfoSIB1 (4 bits)</i>	This number determines the NPDSCH repetitions.
<i>systemInfoValueTag (5 bits)</i>	This information is for the end device to check the validity of SI messages.
<i>ab-Enabled (1 bit)</i>	It indicates whether the access barring is enabled.
<i>operationModeInfo (7 bits)</i>	This value indicates the mode of operation if standalone, guard band or in-band mode.
<i>spare for future use (11 bits)</i>	Reserved for future use.

The transport blocks size is different for the uplink and downlink. As per 3GPP TS 36.213 [3], in NB-IoT, the end device will choose the transport block size ranged from 2 bytes to 125 bytes depends on the upper layer overhead. Non IP traffic needs comparatively lower size, while IP traffic needs larger block size due to the overheads. The maximum allowed transport block for the NPDSCH is 680 bits (85 Bytes) Table 5.

Table 5. TBS for NPDSCH carrying SIB1-NB

I_{TBS}	0	1	2	3	4	5	6	7	8	9	10	11	12	13	14	15
TBS	208	208	208	328	328	328	440	440	440	680	680	680	Reserved			

System Information Base

The Signaling Information base is transmitted over NPDSCH. SIB carries the cell selection information, cell access information, and scheduling information. Its periodicity is 2560 ms and it carries cell access information contains barred status, Public Land Mobile Network identity list, tracking area code, Cell ID and intra frequency reselection. Cell selection information contains minimum receiver level and minimum quality level. Optionally SIB has the following information as well, Frequency band indicator, *downlinkbitmap*, NRS-CRS-Power Offset, SI window Length, SI-Radio Frame Offset.

Downlink bitmap determines which subframe to be used for downlink transmission. Radio Frame Offset is used to calibrate the start of SI window. SI-periodicity provides periodicity in terms of radio frames. SI window length provides window size for the SI messages in ms.

Signaling Information Block 2 is carried by NPDSCH channel, that contains RRC, UL power control, preamble power ramping, UL CP length, subframe hopping, UL EARFCN values. RRC carries the following information: *rach-ConfigCommon-r13*, *bcch-Config-r13*, *pcch-Config-r13*, *nprach-Config-r13*, *uplinkPowerControlCommon-r13* [4].

Table 6. SIB2 parameters for RACH

Parameter	Description
<i>preambleTransMax-CE</i> (3, 4, 5, 6, 7, 8, 10, 20, 50, 100, 200)	The maximum number of preambles transmission.
<i>powerRampingParameters</i> (<i>powerRampingStep</i> , <i>preambleInitialReceivedTargetPower</i>)	The power sensitivity and ramping step values.
<i>rach-InforList</i> (<i>ra-ResponseWindowSize-r13</i> , <i>mac-contentionResolutionTimer-r13</i>)	The RACH response window size, contention resolution time.

Narrowband Physical Downlink Control Channel (NPDCCH)

The Narrowband Physical Downlink Control Channel alerts the end device of downlink and uplink resource allocation. The NPDCCH contains downlink control information (DCI), a logical block. It has two formats as illustrated in Figure 7. The Narrowband Control channel element (NCCE) composes of six frequency resources in a subframe. In format 0, there will be only one NCCE, and two NCCEs in format 1.

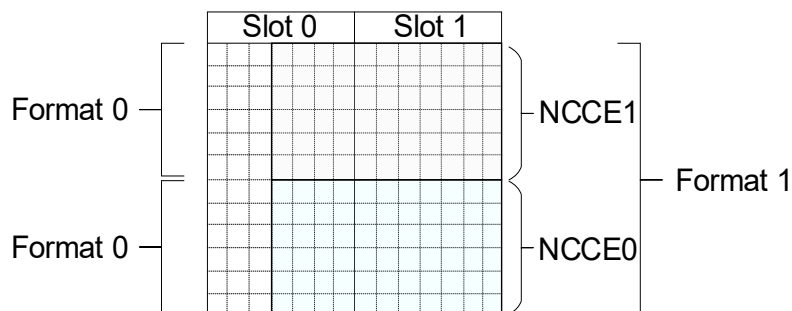

Figure 7. Narrowband Control Channel Elements format

Downlink Control Indicator (DCI): Downlink control indicator carries the critical information such as scheduling delay, resource assignment, subcarrier indication. DCI is categorized into three formats as stated in the below table. Format N0 corresponds to the uplink resource scheduling, Format N1 is primarily meant for downlink scheduling related to the NPDSCH resources.

Table 7. Downlink Control Indicator Formats

DCI format	Bit Length (size)	Purpose/ Usage
N0	23	UL Grant (NPUSCH Scheduling)
N1	23	DL Scheduling (NPDSCH Scheduling) RACH initiated by PDCCH Order
N2	15	Paging and direct indication

Downlink Control Indicator Format 0: It carries Subcarrier indication, Resource assignment, Scheduling delay, Modulation and coding scheme, Repetition number and Redundancy version. Subcarrier indication on the uplink is indicated as per the following Table 8 [3].

Table 8. Uplink resource allocation

Subcarrier indication field (I_{sc})	Set of Allocated subcarriers (n_{sc})
0 - 11	I_{sc}
12 - 15	$3(I_{sc} - 12) + \{0, 1, 2\}$
16 - 17	$6(I_{sc} - 16) + \{0, 1, 2, 3, 4, 5\}$
18	$\{0, 1, 2, 3, 4, 5, 6, 7, 8, 9, 10, 11\}$
19 - 63	Reserved

After attaining the uplink resources, the end device decides transmission block size for the uplink transmission, and the I_{RU} is the corresponding index for the number of resource blocks (N_{RU}) required. The uplink resource mapping is done based on the DCI information obtained from the base station [3], also the timing advancement will be decided as per the signaling information. The maximum delay expected for transmission is 64 frames. The maximum number of NPUSCH repetitions are limited to 128 to control the battery drain for the end device. If the end user is in a poor coverage area, the base station requests for maximum number of repetitions to ensure the delivery of the signaling. Uplink repetitions; the base station can make up to 2048 repetitions to the end device.

Downlink Control Indicator Format 1: It has similar parameters that of format 0, but for downlink channels. The following Table 9 specifies the scheduled delay for the corresponding DCI value obtained. Table 10 specified the number of downlink subframes reserved for the given index value.

Table 9. Scheduling delay (Format N1)

I_{Delay}	k_0	
	$R_{\text{max}} < 128$	$R_{\text{max}} \geq 128$
0	0	0
1	4	16
2	8	32
3	12	64
4	16	128
5	32	256
6	64	512
7	128	1024

Table 10. Subframe allocation for NPDSCH

I_{SF}	N_{SF}
0	1
1	2
2	3
3	4
4	5
5	6
6	8
7	10

Uplink Scheduling

The uplink scheduling is the same as the legacy LTE network. The NB-IoT has the different preamble structure which makes it more robust for the long distance communication. The NB-IoT has the following physical channels: De-modulated Reference Signal (DMRS), NB Physical Uplink Shared channel (NPUSCH), NB Physical Random Access Channel (NPRACH).

Narrowband Physical Uplink Shared Control channel

The NPUSCH composed of either 3.75 kHz or 15 kHz channels. As illustrated in Figure 8, the 15 kHz channels have 20 sub frames (each 0.5 ms) in time scale and each slotted resource carry seven symbols information using OFDMA. Similarly, the 3.75 kHz channels have five subframes in time scale with 48 bearers.

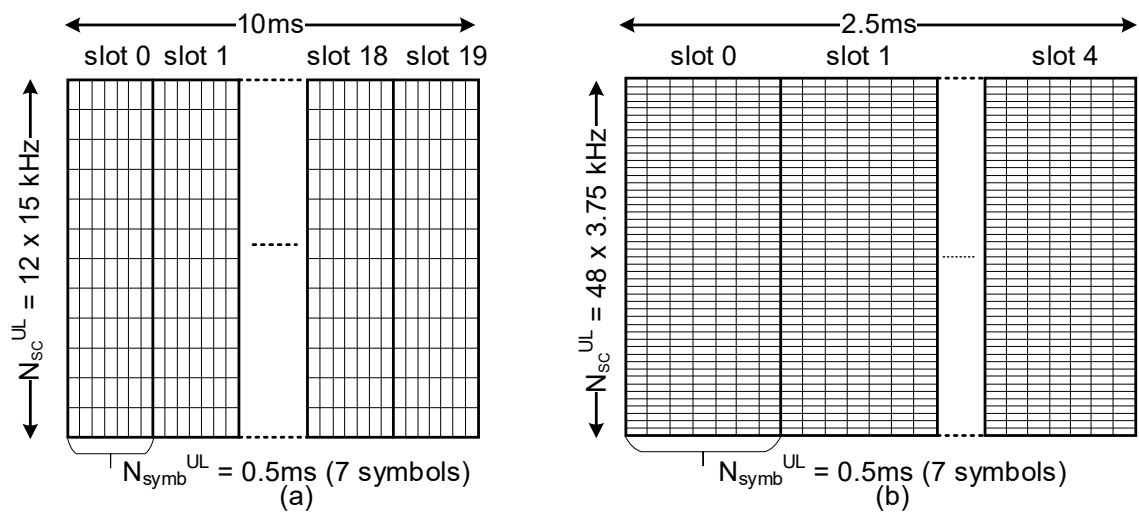

Figure 8. NB-IoT Uplink frame format

In contrast to the legacy LTE, the uplink resources are divided into different resource units as shown in the following Table 11. It accommodates both single tone and multi-tone based on the end device capability. The base station provides the starting index of frequency, and time position on the grid through DCI, which needs to be used by the end device. For example, if the resource unit (RU) 3 is selected (Format 1), the UE occupies three subcarriers and the transmission lasts for 8 slots (or 4 ms). The NPUSCH Format 2 is mainly used for the uplink control information.

Table 11. Uplink resource unit combinations

NPUSCH Format	Δf	N_{sc}^{RU}	N_{slots}^{UL}	N_{symb}^{UL}
1	3.75 kHz	1	16	7
	15 kHz	1	16	
		3	8	
		6	4	
		12	2	
2	3.75 kHz	1	4	
	15 kHz	1	4	

Narrowband Physical Random Access Channel

The NPRACH is one of the critical and primary channels in the initial phase of transmission. Before the end device gets time and frequency resources for transmission, firstly it listens to the broadcast information from the base station. The NPRACH resources are allocated per CE group. The periodicity of the NPRACH resources will be from 40 ms to 2560 ms. The starting time and frequency for the Random access resources are provided in the broadcast channel. The NPRACH resources occupy a group of 12, 24, 36 or 48 channels, this information is provided by the base station.

The frequency resource can further differentiate either single tone (either 3.75 kHz or 15 kHz) or multi-tone (both frequencies) depends on the requirement. End device decides the initial time and frequency for the uplink transmission and the repetitions will be calculated based on the algorithm, which hops the frequency for every other subframe. The preamble sequence is derived based on the Zadoff-Chu sequence as described in the following section. In contrast to the legacy LTE, the preamble will be repeated for robust operation in NB-IoT. The base station provides the following parameters to the end device to assist the initial access.

Table 12. NPRACH parameters

Parameter	Description
<i>nprach-Periodicity</i>	The RACH resource periodicity {40, 80, 160, 240, 320, 640, 1280, 2560}
<i>nprach-StartTime</i>	The index on time scale for the resource grid for the RACH resource {8, 16, 32, 64, 128, 256, 512, 1024}
<i>nprach-SubcarrierOffset</i>	The index on frequency scale {n0, n12, n24, n36, n2, n18, n34, spare1}
<i>nprach-SubcarrierMSG3-RangeStart</i>	The value to estimate subcarrier index for UE support for multi-tone msg3 {zero, oneThird, twoThird, one }
<i>maxNumPreambleAttemptCE</i>	The maximum preamble re-attempt limit {n3, n4, n5, n6, n7, n8, n10, spare1}
<i>numRepetitionsPerPreambleAttempt</i>	The number of preamble repetitions permitted per attempt. { n1, n2, n4, n8, n16, n32, n64, n128}
<i>npdcch-StartSF-CSS-RA</i>	The first subframe for NPDCCH common search space: StartSF * MaxRepetitions \geq 4. {v1dot5, v2, v4, v8, v16, v32, v48, v64}
<i>npdcch-Offset-RA</i>	It index of first subframe for NPDCCH common search space. {zero, oneEighth, oneFourth, threeEighth}

In principle, the base station allocates the RACH resources based on the coverage level. There are three levels which are categorized based on the MCL value. However, the network operator can manually set the number of resources supporting the particular coverage level. The UE calibrates the received signal strength and decides the coverage level, based on which the number of re-transmissions shall take place.

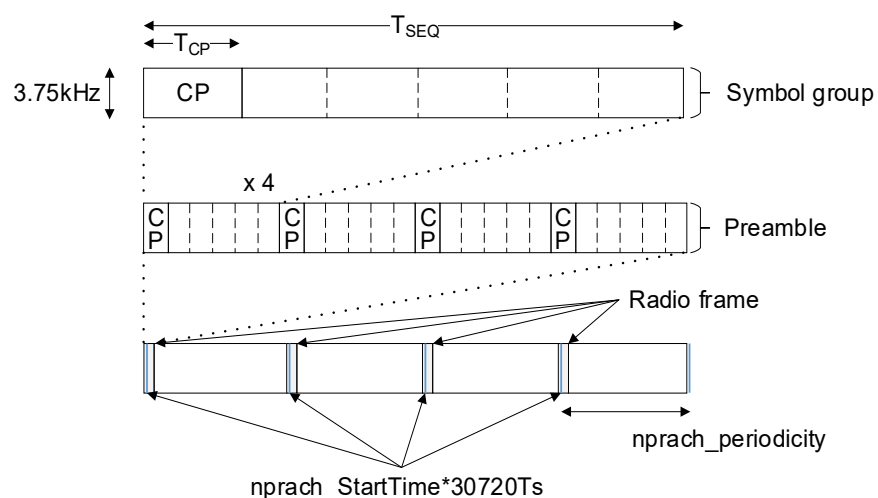
**Figure 9.** LTE NB Preamble format

LTE Narrowband Preamble: The LTE NB has two types of preamble formats. As illustrated below, the preamble is made up of CP and the 5 sequence groups. Each preamble comprises 4 repetitions of symbol groups. The CP length will be either 67 μ s in format 0 or 267 μ s in format 1.

Table 13. LTE Narrowband Preamble types

Preamble format	T_{CP}	T_{SEQ}
0	2048Ts	5 * 8192Ts
1	8192Ts	5 * 8192Ts

Each preamble is repeated 4 times, however, every time the transmitting frequency hops as per the equation stated in 3GPP TS36.211 10.1.6.2. Only the starting subcarrier is allocated as per SIB information received from the base station, next hop is deduced from the same equation. This hopping is limited to the 12 subcarriers.

Random Access procedure

As illustrated in Figure 10, it starts with base station broadcasting the synchronization signals to the UEs. During NPSS, UE gets time and frequency synchronized to the base station. During the NSSS, UE detects the frame structure and physical cell identity. After synchronization, UE listens to the broadcast channel (NPBCH) for uplink scheduling information. Upon retrieving MIB information, UE knows the access barring status, operation mode, SFN, Hyper SFN, and SIB1 scheduling information. Upon searching through SIB1, UE gets to know the minimum receiver level, PLMN ID, TA code, cell status, and scheduling information.

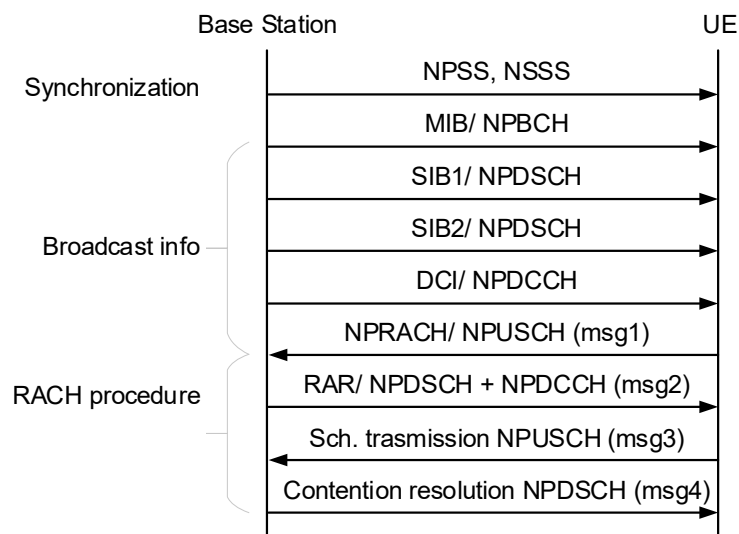

Figure 10. NB-IoT Random Access Procedure

SIB2 contains the radio resource configuration, time advancement, NPRACH configuration, uplink/downlink scheduling information. The downlink control information (DCI) carries the resource allocation for random access procedure, also the scheduling delay. Upon reading the uplink resource allocation, for random access procedure, the UE adjusts the uplink timing as per the downlink control indicator information, and then start to transmit the preamble over randomly chosen frequency. As described in section 0, the preamble comprises five symbol groups transmitted over different frequencies. Depends on the scheduling information received in SIB, UE repeats the preamble at a maximum of 128 times. Figure 11 illustrates four repetitions on the uplink frame.

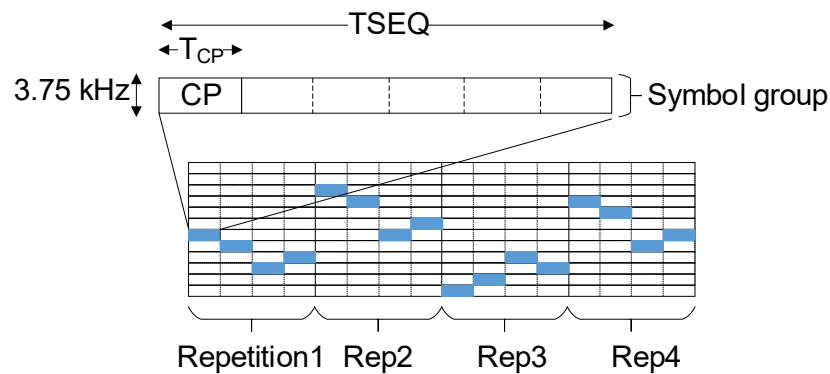

Figure 11. NPRACH Preamble Repetitions

Contention mechanism:

Random access preamble allocation: The base station broadcasts Random Access (RA) preamble information. The UE transmits the preamble during the random access resource provided. There could be a collision with other UEs which is detected at the base station. *Random Access Response (RAR) allocation:* The UE then listens to the RAR window for time/frequency resource information. Based on the information, the UE adjusts its uplink time and gets ready for radio resource request.

Radio Resource Request: UE initiates a Radio Resource Control (RRC) re-request to the base station to fulfill the number of bytes of information it wants to send. *Contention resolution:* The base station at this stage decodes the request and reverts an identifier that is uniquely assigned for the UE. Only the correct user can decode it and succeed with RACH procedure.

2.3 Coverage Assessment

In this section, we estimate the link budget for both uplink and downlink NB-IoT channel. We consider that The minimum SNR required at -6 dBm and relatively high noise factor 6 dB. The NB-IoT PRB is 180 kHz that produces low noise floor compared to the high bandwidth. This assumption fits the requirement of the thesis, where the coverage for the sensors will be poor.

Downlink power budget

As per the 3GPP, the transmitting power at the base station is 43 dBm. In this estimation, the transmitting antenna gain and the losses are assumed as zero. Apply the general link power budget equation to estimate the MCL:

Table 14. Downlink power budget for NB-IoT

Parameter	Value
P_{TX} – Transmit Power	43 dBm
G_{TX} – Transmit antenna gain	0 dBi
L_{TX} – Transmission loss	0 dB
SNR_{min} –SNR sensitivity	-6 dBm
B – Channel bandwidth	180 kHz
NF – Noise factor	6 dB
G_{RX} – Receiver antenna gain	0 dBi
L_{RX} – Receiver losses	0 dB

$$L = P_{TX} + G_{TX} - L_{TX} - SNR_{min} + 174 - 10 \cdot \log_{10}(B) - NF + G_{RX} - L_{RX}, \quad (3)$$

where L (dB) = 164.44 dB

With the above assumptions, the MCL is estimated as 164.44 dB is 20 dB gain compared to the GSM signal and the highest ever offered by any IoT technologies. This MCL ensures that the signal penetration is as deep as it can reach indoors and the basements. The coverage will be greatly improved based on the above estimation. Coverage distance for different frequency bands are estimated using free space path-loss model (FSL).

$$FSL_{(dB)} = 32.44 + 20 \cdot \log_{10}(d_{km}) + 20 \cdot \log_{10}(f_{MHz}), \quad (4)$$

Figure 12 illustrates the downlink coverage distance for various frequency bands (LTE and GSM). In the urban area where the noise factor is quite high, the coverage will be very less in all bands, especially in 1900 MHz band it is just below 10 km. However, in this thesis, the assumption is that the coastal area will have less interference and can be considered a rural condition. At noise figure 5.0, the coverage distance will be about 22

km from the base station, which is quite efficient with the transmission power budget of 43 dBm.

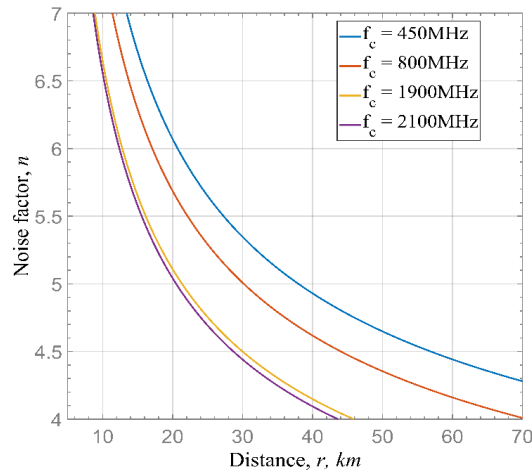

Figure 12. NB-IoT Downlink coverage

The lower bands provide extended coverage, but the data rates will be minimal. Utilizing the LTE band will reduce the coverage compared to that of GSM. However, the interference from other ISM band signaling will be one of the factors that affect the performance of the system. While the base station has no obstacles or the noise factor is less the NB-IoT downlink resources will support 40 km radius. The number of downlink resources will be over-utilized by the base station if more devices are located far away, which require many repetitions. If the coverage needs to be extended further, the transmit power need to be increased, however, it is not standardized as per the 3GPP framework.

Uplink power budget

In the uplink scheduling, NB-IoT supports two granularities, single tone (either 3.75 kHz or 15 kHz) and multi-tone (3.75 kHz and 15 kHz). As per the 3GPP, the transmitting power at the end device is 23 dBm. In this estimation, the transmitting antenna gain and the losses are assumed as zero. Below assumptions are interpreted for this case study in uplink:

Table 15. Uplink power budget for NB-IoT

Parameter	Value
P_{TX} – Transmit Power	23 dBm
G_{TX} – Transmit antenna gain	0 dBi
L_{TX} – Transmission loss	0 dB
SNR_{min} –SNR sensitivity	-6 dBm
B – Channel bandwidth	3.75 kHz and 15 kHz
NF – Noise factor	3 dB
G_{RX} – Receiver antenna gain	0 dBi
L_{RX} – Receiver losses	0 dB

For the carrier bandwidth 3.75 kHz, L (dB) = 164.25 dB and for 15 kHz subcarrier, L (dB) = 158.23 dB, which is improved compared to the other IoT technologies. The bandwidth of the IoT device is optional for the use cases.

As the uplink bandwidth will be as less as 3.75 kHz, it provides improved coverage compared to that of 180 kHz uplink bandwidth. Since the IoT device uses battery power, the transmit power is limited to 23 dBm (Power class 3) to serve for a longer duration. Coverage distance for different frequency bands are estimated using FSL.

From Figure 13, it is observed that for 1900 MHz band provides about 7 km in the urban environment where the interference, noise is quite high. In the rural condition, where the noise factor will be about 5.0, the coverage will be about 15 km from the base station. Despite the fact that the MCL remains 164.25 dB while transmitting using 3.75 kHz bandwidth.

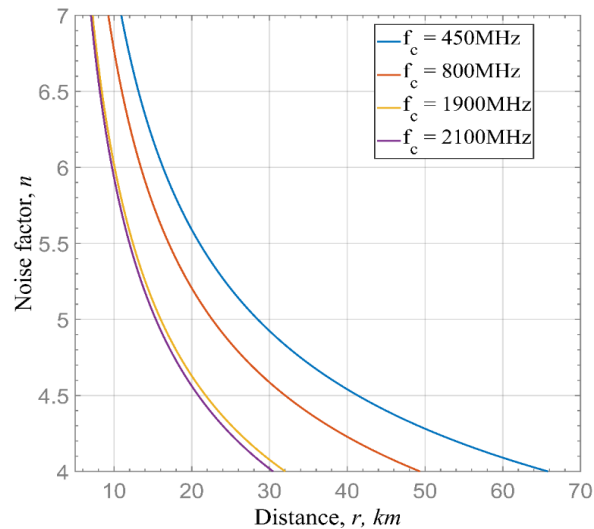

Figure 13. NB-IoT Uplink coverage

When the sensor uses multi-tone, the MCL will be reduced to 158.23 dB, which is still high for the indoor and basement scenarios. The only limiting factor for the greater coverage is the sensor battery, which has to be efficient and durable. It is possible to use class 5 (20 dBm) or class 6 (14 dBm) devices based on the requirement, which offers extended sensor lifespan.

2.4 Energy Consumption

As per the 3GPP, the NB-IoT compliant sensor shall support 10-year battery life. In line with the requirement, it introduced two power saving features: i.e. PSM and eDRX. The notion of power saving is to turn off the end device for a certain duration and turn on

after a predefined cycle, that conserves the battery power. Although the both PSM and eDRX aimed to conserve energy, the purposes are a bit different.

PSM mode suits for the application where the data transmission is less frequent, while eDRX mode suits for frequent data transmission. PSM mode provides longer battery life compared to that of eDRX due to long idle times as explained in the following.

Power Saving Mode

The 3GPP body has specified the PSM mode procedure in TS 23.682 (Release 12). It is mainly applicable where the end device static in nature which does not require connection procedure frequently. PSM has no support in the circuit-switching domain on the network side [5]. PSM should only be used by the UEs using the packet-switching domain, SMS and mobile originating IMS or circuit-switching services. As illustrated in Figure 14, there are three stages in PSM.

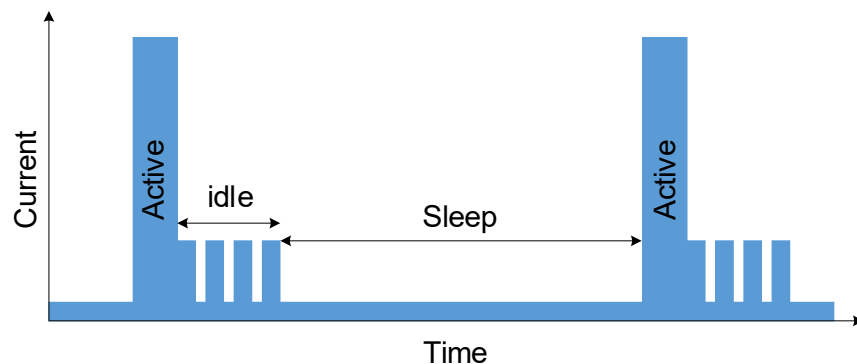

Figure 14. Power Saving Mode [37]

In Active cycle, UE transmits the data and then change the status to receive (idle) during which UE decodes the incoming messages. If no further action required, the device will enter into sleep mode. The end device will request active time value when connects to the base station in order to activate PSM mode. The base station which supports the PSM mode will acknowledge the usage of PSM mode and provide the active time value to the end device.

This mode is primarily suitable for static sensors connected to the legacy LTE network where no need of re-establishing a connection. The paging window remains constant, but the value can be extended by the network provider accordingly.

The LTE core network registers the active time value assigned to the end device, and it can be updated when the end device wants to modify. While the device is in sleep period, the base station will accumulate the incoming messages and pushed to the end

device once it is activated. The end device can sleep a maximum of 413 days and the maximum awake time is 186 minutes.

extended Discontinuous Reception mode

This implementation is an advancement in power conserving methods, the end device periodically enters into idle mode to listen to the incoming messages, instead of directly jumping to the active cycle. Hence, there will be a lag in listening to the paging messages, which is still tolerable for NB-IoT devices. It is beneficial if the incoming messages are frequent, as this mode simply increase the end device availability to receive.

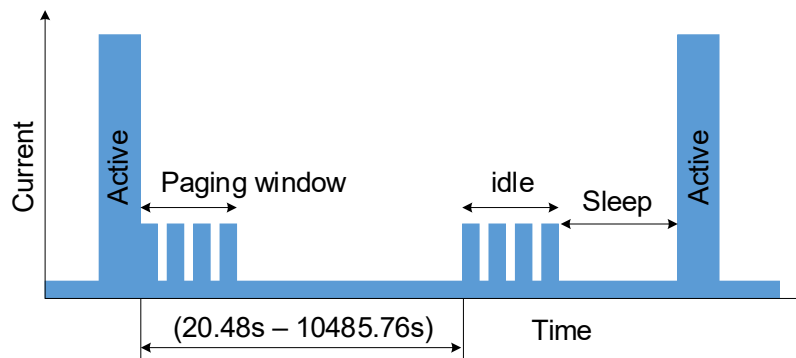

Figure 15. extended Discontinuous Reception mode [37]

This mode suits for the cases where the user moves frequently that requires establishing connection. The base station will still buffer the incoming data until the end device is connected. The following Table 16 shows the eDRX cycle length comparison between LTE M1 and NB-IoT. Due to the longer eDRX cycle, NB-IoT device lasts longer than LTE M1 device. It means the Cat M1 availability is higher that does not impose many delays, it suits for machine type communication.

Table 16. eDRX cycle length comparison

Cat M1 (seconds)	NB-IoT (seconds)
5.12	20.48
10.24	40.96
20.48	81.92
40.96	163.84
81.92	327.68
163.84	655.36
327.68	1310.72
655.36	2621.44
1310.72	5248.88
2621.44	10485.76

3. NB-IOT FOR CARGO SHIPS

In this chapter, the implementation methods, coverage analysis, their advantages, and shortcomings are described. In addition, the system model, connectivity assessment and simulation model are briefed.

3.1 Deployment options

In this section, the NB-IoT implementation scenarios are explained. It is worth noting that the Class 3 NB-IoT sensors suit best for the monitoring purpose as the transmitting power is limited to 23 dBm, which covers longer distances.

3.1.1 Direct Access with Coastal LTE Network

In this method, each container will be fitted with NB-IoT sensor and they directly interface with the onshore LTE base station when it coverage. In general, the cargo ships sail in 15 km proximity to the shore most of the times, to be able to reach the shore in case of urgency. However, the distance to the coast varies timely and depends on various factors. In this thesis, it is assumed that the NB-IoT will be deployed in 900 MHz band that provides enhanced coverage. The base station is assumed to be located within 5 km distance from the coastal line. During the ideal scenario, the sensors on the ship will transmit the data directly.

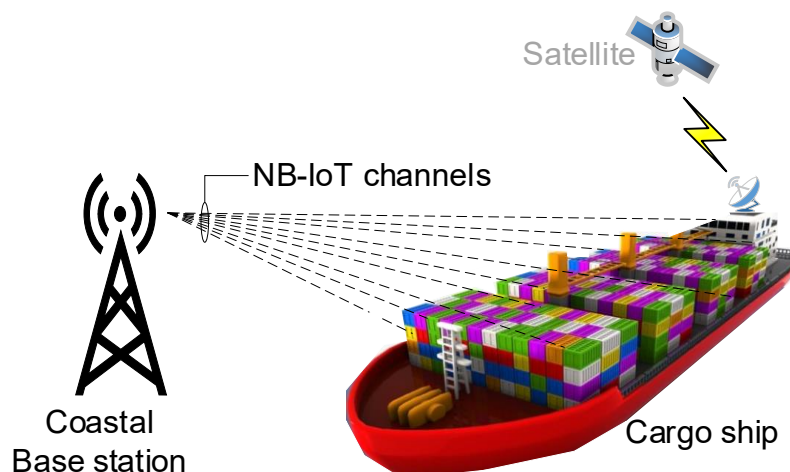

Figure 16. Direct interface with onshore LTE network

As detailed in section 2.2, the random access resources are allocated per CE as default. In this method, all the random access resources can be allocated for the CE2 where the coverage will be poor. It is important to note that, 3GPP introduced repetitions in NB-IoT for improved diversity gain and the number of repetitions will be 2048 in downlink and 128 times in uplink for poor coverage. This causes a significant bottleneck for the uplink resources, also the downlink utilization is low as the information has to be repeated for all the sensors attempting to access the base station. In addition, the latency of the data packets can be up to 10 seconds due to the repetitions.

As per the NB-IoT standard, the CP and preamble vary based on the service requirement. The preamble format 0 with CP length $66.67 \mu\text{s}$, serves up to 10 km radius. The distance between the base station and the sensors is assumed to be greater than 20 km for the analysis. Therefore, the preamble format 1 with a CP length of $266.7 \mu\text{s}$ suits the purpose here, which could bear the delays. Even though the preamble and uplink data are repeated, the mean transmits delay will remains minimal in this method.

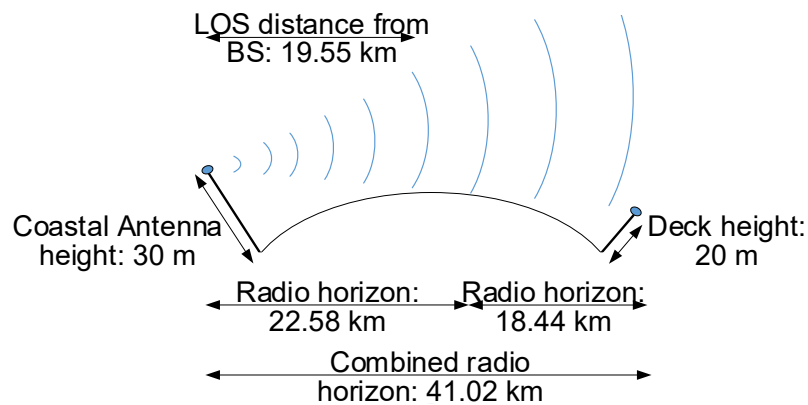

Figure 17. Radio LOS and horizon distances (option 1)

As per the coverage assessment analysis in section 2.3 and Figure 17, the NB-IoT complaint sensor can transmit up to 22 km while the noise factor is 5.0. Likewise, the base station can transmit up to 30 km at the same level of the noise factor. The Line of sight (LOS) distance from the coastal base station, whose antenna is mounted at 30 m height, is about 20 km. Although the LOS is the key metric for successful transmission, we also need to consider the radio horizon distance from the transmitter to the receiver. In this method, the combined radio horizon is 41 km while the sensors are assumed to be mounted on the cargo ship whose deck is 20 m above the sea level.

The coverage will be at least 19 km and a maximum of 40 km depending on the LOS and the frequency band used for the deployment. In this method, the sensors may experience longer outages, during that time the data packets will be sent to the Satellite gateway. Once the LTE network is discovered, all the sensors attempt to access the random

access channels. With the current state of the art technology, the devices will not get the channel due to the huge contention. This problem can be mitigated by randomly distributing the back-off value, this workaround may reduce the collision to some extent. The following are the advantages and shortcoming of this implementation.

Advantages: Sensor information can be relayed via cheaper LTE network rather than expensive Satellite link to the cloud. Each container health reports can be flexibly reported to the cloud, no dependency on other sensors onboard. Direct access deployment will reduce the failures in the communication chain.

Shortcomings: The maximum LOS distance is approximately 19 km from the coastal base station, after which the sensors have to resort satellite link. If multiple jumbo cargo ships pass through the same base station, assuming 3×10^4 K sensors attempting to access the channel simultaneously leaves the base station no choice, but to bar the access for certain duration. Eventually, a tiny amount of data could be transmitted. Due to high volumes of access requests, NB-IoT resources are wasted for RACH, instead of actual uplink/downlink data traffic.

3.1.2 Interface with Ship Base Station

This implementation is an extension and optimization to the previous method. From the above scenario, when the sensors experience LTE network outage and discover the network, all of them tries to send data. The LTE access network will be overloaded with the random access mechanism and the resources are over-utilized for the repetitions. If the sensor reaches the maximum number of preamble attempts, it will drop the packet. The NB-IoT sensors are quite economical in hardware design, those can store limited information and do not have different radio modules to transmit the data via different LPWAN technology. From the previous scenario, it is observed that the sensor battery will be drained due to maximum repetitions and the poor coverage.

In order to address the above-mentioned concerns, the base station needs to be located within the coverage, which helps to cut down the battery consumption of the sensors onboard. If the base station is always available for the sensors, the access network will have handful resources and no need for the retransmissions. Unlike the previous method (direct access), there will not be a sudden spike in the traffic load on the base station due to the evenly distributed load. Ideally, each cargo ship needs to be fitted with a base station that also compliments for other mobile services.

The base station will be installed and its antenna will be mounted at 30 m altitude. Note that the ship deck will be at least 20 m from the mean sea level, adding to the antenna height it will be 50 m. This will ensure the longer coverage distance from the ship base station to the onshore LTE base station. In this method, the base station accumulates the received data packets over a period (preferably, for the packet inter generation time). When it discovers onshore LTE network, it will establish a connection via NB-IoT interface. The NB-IoT uplink channel offers 250 kbps using multi-tone transmission, 20 kbps using single-tone.

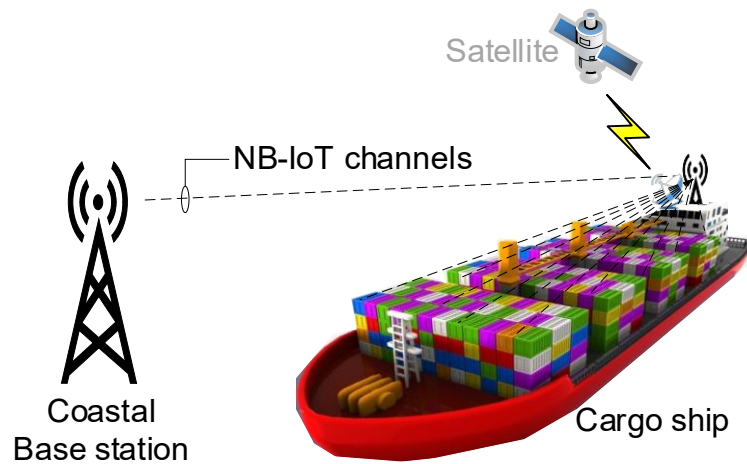

Figure 18. Interface with ship mounted base station

If each sensor produces 200 bytes of payload per node for an hour, and the base station accumulates the data for two hours, all 2000 sensors produce 0.8 MB data. With multi-tone transmission, the data can be transmitted in 25.6 seconds. Hence, the coastal base station will only receive one request from the ship base station for the channel access. When multiple ships sail across the coast, the base station will only spend a few resources for the offshore communication. If no coverage until the predefined window, then the data will be forwarded to the satellite gateway onboard.

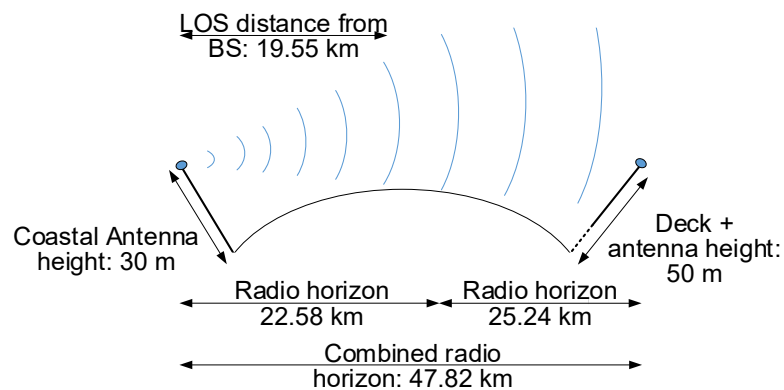

Figure 19. Radio LOS and horizon distances (option 2)

As per the below estimate (Figure 19), with the given antennas heights the combined radio horizon will be 47 km where the LOS is about 20 km. With 43 dBm transmit power, good LOS and unobstructed path; the base station can transmit up to 40 km. In this method, the communication link is mainly between ship base station to the coastal base station. We consider this link will be NB-IoT interface that can suffice the requirement of sending sensor data. The legacy LTE signal cannot reach longer distance compared to the NB-IoT, provides 164 dB MCL, that is tailored for the sensor data and serve long distance as well.

Therefore, to relay the aggregated data, the power consumption will be quite low and the base station can offer extended coverage since its transmitting power is 43 dBm, which is higher compared to that of the sensor. Due to the shorter communication distance, all the NPRACH resources can be configured to support CE level 0 that requires minimal repetitions. Hence, the congestion will be avoided on the ship base station. Although the mean transmit delay from sensor to the ship base station will be minimal, the overall mean transmit delay to the onshore data center will be depended on the communication link from ship BS to the coastal BS, the interval over which the aggregated data will be relayed.

It is imperative to dimension the number of sensors, amount of traffic and the sampling interval for installing the base station on ships, as some of the recent cargo ships capable of carrying 20 thousand containers (fitted with one sensor each) which is challenging. In light of offshore LTE network availability; this implementation will benefit the operators to relay the data even for the longer distances.

Advantages: The packet loss will be reduced compared to the previous case, which uses direct access. The problem of excessive contention in the access network is minimized. Sensors lifetime will be significantly improved since the base station is just a few tens of meters from the sensors and not necessary to retransmit all data all the time. The coastal base station will not face any congestion even in the peak traffic hours. Since NB-IoT interface is utilized and the antenna is mounted at high altitude on the ship, the coverage will be improved to 40 km.

Shortcomings: The overall transmit delay will be higher compared to that of direct access implementation, due to packet accumulation at ship BS. The coverage distance is not significantly improved. It requires capital investment to install a base station on the ship and maintain it. The ship BS will be the single point of failure if no failsafe mechanism in place.

3.1.3 Interface with Unmanned Aerial Vehicle Base Station

This implementation will be a combination and optimized version of the previous two methods. Firstly, there has to be a mechanism to avoid the access network overloading, secondly, the communication distance shall be significantly improved, and thirdly the sensor lifetime shall be longer. To increase the communication distance, the transmitting power of the sensors cannot be increased that will drain the battery. The ship base station addresses the access congestion and the repetition problems, but it only offers 40 km communication distance. To address this problem, an UAV mounted base station that acts as the IoT access point will be installed on the cargo ships.

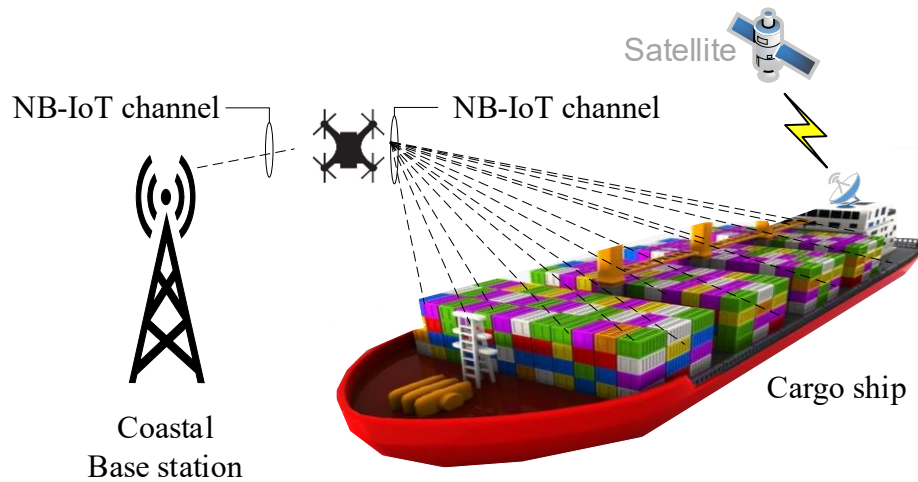

Figure 20. Using mobile IoT base station using UAV

The UAV base station collects the sensor data and fly few a meters high and away from the ship. The maximum distance that UAV fly is same as the CE level 0. The UAV base station then aggregates the data for a predefined period and relays to the onshore coastal base station using NB-IoT interface. The UAV base stations maintain the queue which can hold the packets up to inter packet generation time. The coverage can be extended substantially from the sensors to onshore LTE network.

While the UAV flies at an altitude of 100 m it provides the LOS distance 35.7 km. The radio horizon between the UAV to the sensors is 60 km, and 64 km to the coastal base station. Thus, the overall communication link can be 36 km to 123 km using UAV base station. The limiting factor is the transmitting power of LTE base station that allows a maximum of 40 km in good environmental conditions.

The UAV in loop extends the coverage to 20-40 km without modifying the existing NB-IoT interface. Multiple UAVs will be deployed on the cargo ship to ensure the longer LTE network availability. The packet loss at the sensors will be nullified in this method. If no

LTE coverage available to the UAV, it will relay the accumulated data to the Satellite link. The mean transmit time will be high compared to that of direct access implementation, as the local BS accumulates the data for some period.

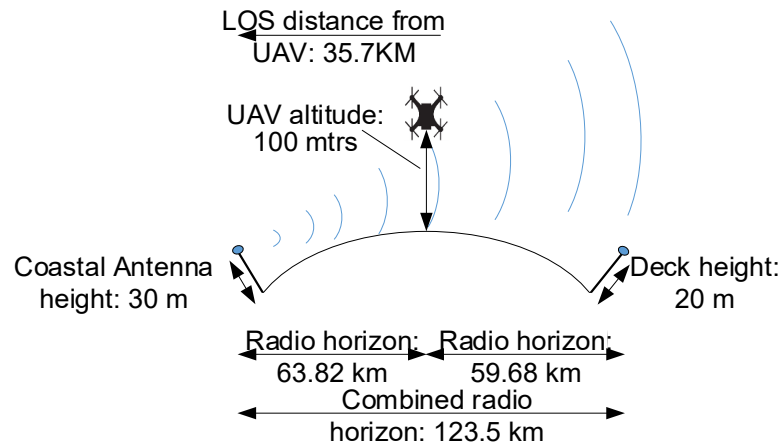

Figure 21. Radio LOS and horizon distances (option 3)

Advantages: Packet loss will be zero since the NB-IoT configuration is setup for the CE level 0. The coverage distance will be up to 80 km from the coastal base station. Sensor lifetime will be greatly improved than direct access implementation, as the UAV will be in close proximity to the ship. Due to multiple UAVs deployed on board, the communication link will be resilient.

Shortcomings: Interference and spectrum overlap among the multiple UAV base stations may through challenges in operation. The transmit delay will be higher in this method; it does not suit for the applications that require prompt action. Rough weather in the sea will be harmful to the UAV operation. Pirates and hackers are possible risks for UAV operation.

3.1.4 Backup Plan during LTE Network Outage

As detailed in the above sections, the coverage can be extended up to 80 km from the costal LTE base station to the cargo ship. Always, when the LTE coverage is not discovered, the accumulated packets will be redirected to the conventional satellite channel. For ship BS and UAV implementation there can a mechanism to detect the LTE coverage on the go and re-route the packets to Satellite channel in the absence of the LTE/ EGSM coverage for a long duration (eg: 4 hrs).

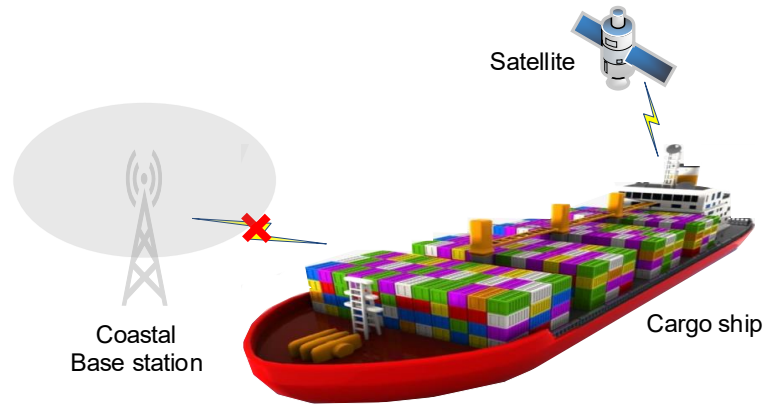

Figure 22. Backup network during LTE network Outage

This failsafe mechanism is only to assure the reliability of the packet delivery. The mean transmit duration will be higher as the latency will be due to the summation of packet buffering on local BS and then relaying to the satellite link.

3.2 System Model

The system comprises LTE Narrowband complaint random access procedure, which features NB-IoT. The idea is to simulate the congestion scenario on NB-IoT access that occurs for the case study of cargo containers tracking using onshore LTE network. The system is designed to emulate the initial contention mechanism for different implementations mentioned in the above section. The random access mechanism is detailed in section 2.2.

Table 17. System parameters

Parameter	Value
N	Number of sensors
Λ	Packet arrival intensity
$Y1$	Mean connect duration
$Y2$	Mean outage duration
T_{delay}	Excessive delay threshold
C	Max. RACH channels
T_{RACH}	RACH periodicity
K	Number of RACH repetitions
M	Max. preamble repetitions
E	Battery capacity
F	Message frequency/day
S	Packet size
a	Width of the coast that can be reached from the ship
b	distance between the ship and coastal line
r	NB-IoT BS coverage
L	RV_uniform var(0, a)
Λ	BS spatial intensity of
v	Velocity of the ship

Assumptions: It is assumed that the base stations will be located within 5 km range from the coastal line. Base station density has been assumed based on the ideal scenario. The NB-IoT base station antennas are not tilted mechanically, to provide enhanced coverage into the sea. The Container ship sails approximately 18-60 km away from the coastal line most of the times. The velocity of the ship is 37 kmph on average. All RACH resources are capable of supporting CE level 3 with MCL of 164 dB. All the sensors are assumed to get channel allocated after successful RACH procedure.

Metrics of interests

In this thesis, we primarily focus on three metrics i.e, packet loss probability (end-to-end), mean transmit delay and sensor lifespan. The packet loss probability for the given system parameters against the overall network load (intensity of packets generated) will provide the insights of the practical implementation challenges. The mean transmit delay is another metric to estimate how the system evolved over the given traffic load, and the availability of the LTE network, as well as the preamble retransmissions. Sensor lifespan is another metric that will be crucial to estimate the performance of the system, it will be assessed against the given traffic load, LTE network availability, and the preamble retransmissions.

3.3 Connectivity Assessment

The base station will be located within a km from the coastal line as illustrated in the following Figure 23. The cargo ship fitted with NB-IoT sensors assumed to be sailing across the coast in trajectory v . The connectivity with the coastal infrastructure for both direct access and Ship base station implementations is modeled as follows.

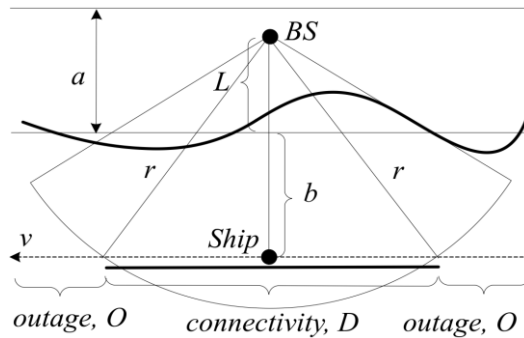

Figure 23. Connectivity model for direct access

In the above illustration, the cargo ship will be sailing within b kilometers away from the coastal line, which is the coverage distance of the base station. L is the distance from the base station to the seawaters. The base station coverage is r km radius, D is the

duration that a ship spends within a base station coverage and O is the duration during which there will not be coverage from the onshore LTE network. Mean duration that a ship spent within the coverage is represented as follows:

$$E[D] = \int_0^a 2(b+x) \tan \cos^{-1} \left(\frac{b+x}{r} \right) \frac{1}{a} dx \quad (5)$$

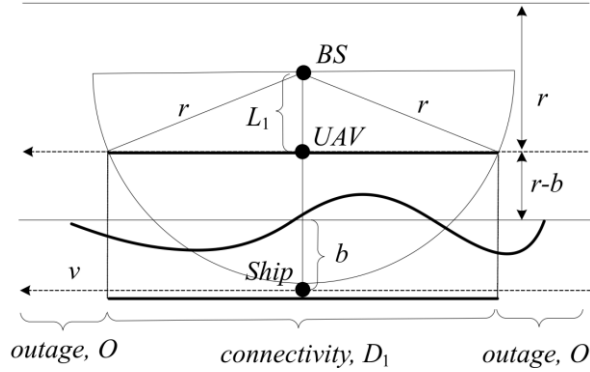

Figure 24. Connectivity model for UAV Base station

The connectivity model for the UAV assisted NB-IoT is illustrated in Figure 24. In this illustration, the UAV can fly a few kilometers towards the coast using prior learned positioning knowledge, still reachable to the sensors on the ship. The maximum distance that UAV can fly is the radius of the UAV base station coverage r . The maximum distance between sensors to the onshore LTE base station can be $2r$ kilometers. The connectivity duration $D1$ will significantly improve using UAV based solution under the same condition that of direct access and Ship base station.

$$E[D] = \frac{r}{2r-b} \int_0^r \frac{2\sqrt{(r^2-x^2)}}{r} dx + \frac{r-b}{2r-b} \int_0^{r-b} \frac{2\sqrt{(r^2-x^2)}}{r-b} dx, \quad (6)$$

3.4 Simulation Model for RACH

Pseudo random-number generator

Two pseudo-random number generators are used to model the simulator. In order to emulate the RACH procedure, the simulator uses random.randit function which is an in-built function in python, to choose an integer of the given range. Secondly, to simulate the Poisson arrival process, random.expovariate function is used, which generates exponentially distributed interarrival times.

Event list

The event list is a set of events, whose execution time stamp is prefixed and arranged in incremented time scale. Each simulation will have an event list that can be deleted,

rescheduled and a new event can be inserted to the list. The event activation and deactivation can be done in the order of execution time. If the simulation time expires and the list is pending for execution, the residual events will not be simulated. It is possible to run single-thread or multi-thread simulations those share the event and prioritize the events that occur at same time.

Discrete Event Simulation

The system in the time domain evolves as a discrete sequence of event chronology. The system's state changes are consistent at a given time. A list of completed events and pending event schedule are tracked. Event scheduler handles the event registry to perform in the correct order. Unlike continuous simulator, the discrete event simulation has the feature to jump the time frame for event execution. The execution is performed in equal time slots throughout the simulation, during which the corresponding event takes place, thus faster execution.

Data collection techniques

Detecting steady state: The initial results produced from the simulator may not be accurate. During the steady-state period, the simulator stabilizes and yields consistent results. The simulator needs to run for a long duration to nullify the effect of the transient. After the long run the output data to split into small pieces and observe the duration after which the output data remains consistent. The output data will be reliable only after the system reaches the steady state.

Batch means: The simulation will be run once but for a long duration and then filter the desired variable. After removing the transient output, split the observations into batches of equal length. The last output value of the previous batch is likely to get correlated to the initial output value of the next batch. The batch means are uncorrelated and normally distributed. For a long simulation run, where more than 30 batches whose mean is uncorrelated and normally distributed, the confidence intervals are estimated as follows:

$$\left(\hat{E}[X] - 1.96 \frac{\sigma}{\sqrt{k}}, \hat{E}[X] + 1.96 \frac{\sigma}{\sqrt{k}} \right), \quad (7)$$

where $\hat{E}[X]$ is mean of the samples, σ is the standard deviation and k is the number of batches.

Packet arrival modeling

The packet arrival from the IoT sensors is characterized by Poisson process, inter-arrival times are exponentially distributed. The arrivals are independent and non-overlapping in time scale. As illustrated in the following Figure 25, Ar1, Ar1+Ar2 are the times when a new packet arrives, those follow an exponential distribution. The first arrival occurs after time t , while t is the mean time of the arrivals. The mean number of arrivals observed during a given time window is referred to arrival rate.

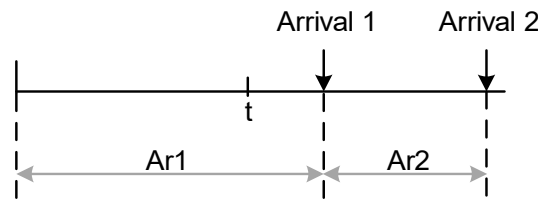

Figure 25. Poisson Process

The time interval can be parameterized as follows:

$$f_x(t) = \lambda e^{-\lambda t}, F_x(t) = 1 - e^{-\lambda t}, \text{ where } \lambda \text{ is arrival rate,} \quad (8)$$

In a given interval, the number of arrivals can be parameterized as:

$$P\{N = k\} = \frac{\lambda^k}{k!} e^{-\lambda}, \text{ where } \lambda \text{ is arrival rate,} \quad (9)$$

Poisson superposition process

As per the Poisson superposition process, the superposition of non-overlapping independent packet arrivals timeline of n nodes will result in an arrival rate which is the same as the summation of arrival rate. All the NB-IoT devices will transmit the packet at different intervals when modeling the base station to receive the packets from n nodes, it follows the Poisson process with the following superposition rule.

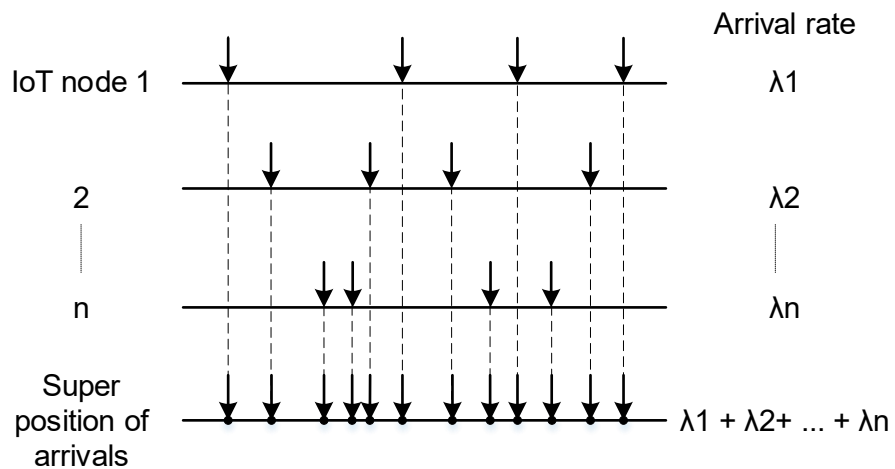

Figure 26. Poisson superposition process

Queuing mechanism

The LTE coverage will not available for some time for the cargo ships or partially available during which the data need to be transmitted. To address this problem, there shall be a queuing mechanism for the ship base station and UAV implementations. All the sensor data will be accumulated and then relay to the onshore LTE base station if the network is discovered within a predefined interval. During the network outage, as illustrates in Figure 27, packets from the IoT sensors will be queued as First In First Out (FIFO) model for infinite size. The excessive delay for the queuing will be set for the ship mounted base station and UAV based base station, after which the packet will be dropped from the queue. Whenever the network is restored, the packets will be relayed over NB-IoT channel to the onshore LTE base station.

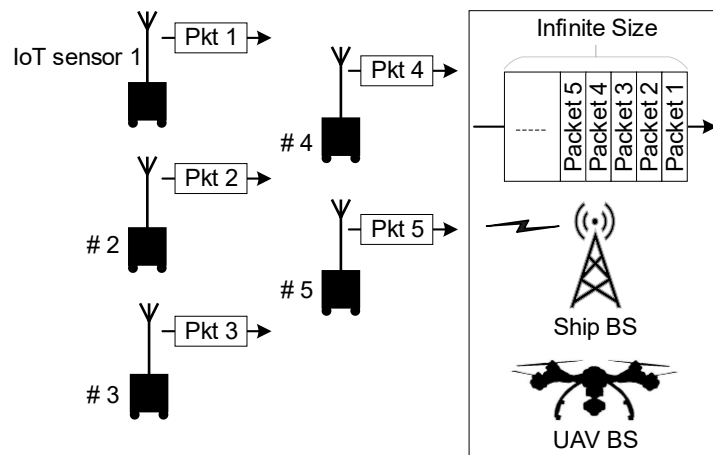

Figure 27. Queuing mechanism at relaying point

Python implementation

- **Class Coverage:**

The *coverage* class is a helper function to generate outage window slots for the desired case based on the input values provided. Firstly, the default constructor initials all the variables as zero. This function is called while the simulation is given the scenario. Input variables of this class:

Table 18. class Coverage parameters

Parameter	Description
<i>bs_intensity</i>	Base station intensity (Λ) unit/ km^2
<i>sim_runtime</i>	Simulation length in hours
<i>a</i>	Width of the coast in km
<i>b</i>	Distance between ship and coast in km
<i>r</i>	Base station coverage in km

Parameter	Description
$L1, L2$	Distance from BS to UAV trajectory left in <i>km</i>
v	Velocity of the ship in <i>km/h</i>

- **Class Energy:**

The *Energy* class performs two tasks for the simulation, i.e. calculating the *consumption* and *lifespan* of the sensor based on the input parameters. The consumption is determined based on the average energy spent for packet transmission. The lifespan of the sensor is measured based on the mean energy spent for a given scenario and the available battery capacity.

Table 19. *class Energy parameters*

Parameter	Description
consumption	
<i>retransmits</i>	Number of retransmissions in each CE
<i>idle_time</i>	It is the duration in sec over which the
<i>packet_size</i>	Packet size in Bytes
lifespan	
<i>mean_energy</i>	Mean energy spent per packet
<i>battery_capacity</i>	Battery capacity in Watt-hour
<i>interval</i>	The number of packets per day

- **Class Node:**

The *Node* class creates a node object and initiates the node parameters. The activate method inputs the parameters for the node to get activated. The get method will print the node details if want to check. The *Node* object captures the packet transmission dynamics. The input parameters are described as following:

Table 20. *class Node parameters*

Parameter	Description
<i>name</i>	The name of the sensor
<i>created_time</i>	The time stamp in s when the packet is created in the sensor
<i>transmit_time</i>	The time stamp in s when the packet is transmitted to the BS.
<i>tx_delay</i>	The transmit delay from the sensor to the base station in s
<i>tx_channel</i>	The transmit channel number 98: fails to transmit due to excessive delay 99: fails to transmit due to max preamble re-attempts finished
<i>tx_status</i>	F: Fails to transmit In-Progress: Either in outage or waiting for re-transmission Done: packet transmitted successfully.
<i>fail_attempt</i>	The number of preamble re-attempts
<i>failed_log</i>	The vector of timestamp with the failed transmission
<i>excess_delay</i>	The count of packet loss due to excess delay
<i>energy</i>	Energy consumed per each packet transmission

- **Class Rach:**

The *Rach* class is the primary function that performs the contention procedure and simulates all three scenarios designed for this thesis. The *contention_procedure* method takes the number of nodes contending for the channel during the given time slot and returns the success nodes and failed nodes separately. The *rach_direct*, *rach_ship_bs* and *rach_UAV_bs* methods take the following inputs and return various statistical information like the number of packet loss due to excess delay, packet loss due to maximum preamble reattempts, transmit delay, sensor lifetime, average energy spent. The code has been optimized to reuse ship BS scenario for UAV BS except for the outage intervals.

Table 21. *class Rach parameters*

Parameter	Description
<i>sim_runtime</i>	The overall simulation length
<i>lmbda</i>	The packet arrival intensity, <i>packets/h</i>
<i>Nodes</i>	The number of the sensor to be simulated
<i>bs_intensity</i>	The base station intensity, <i>unit/km²</i>
<i>re_attempt</i>	The maximum allowed preamble re-attempts in CE
<i>packet_size</i>	Packet size in <i>Bytes</i>
<i>battery_capacity</i>	Battery capacity in <i>Watt-hour</i>
<i>case</i>	2: for ship_bs scenario 3: for UAV_bs scenario

The following illustration provides a high-level implementation for all scenarios. The main difference is that in the ship BS and UAV implementation there exists a buffer that holds all the incoming packets from the sensors until the base station gets the opportunity to relay to the onshore LTE base station or the packet buffer time exceeds the packet intergeneration time.

In the following implementation the contention at ship base station/ UAV base station will be a bit congested, however, the local base station will be always in the coverage. Hence, almost every packet will be transmitted to the local BS. Whenever the local base station discovers the coastal LTE network, again the RACH procedure will be initiated. However, it requires only one NB-IoT channel to relay the buffered data from the ship which was aggregated from all sensors. The outage intervals are estimated based on some data points collected for The Republic of Africa coastal region, it may not be ideal around the globe, but just to provide an estimate.

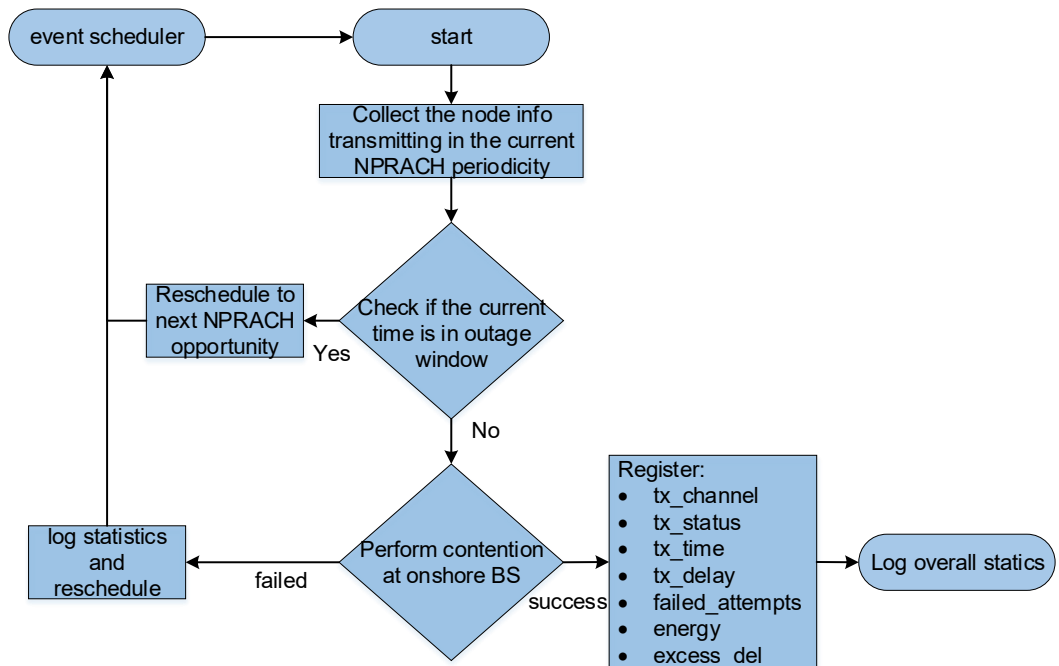

Figure 28. Direct access implementation

In this method, the ship base station and the UAV base stations are assumed to get the NB-IoT channel within least amount of uplink resources and the aggregated data will be transmitted with full data rate over a channel.

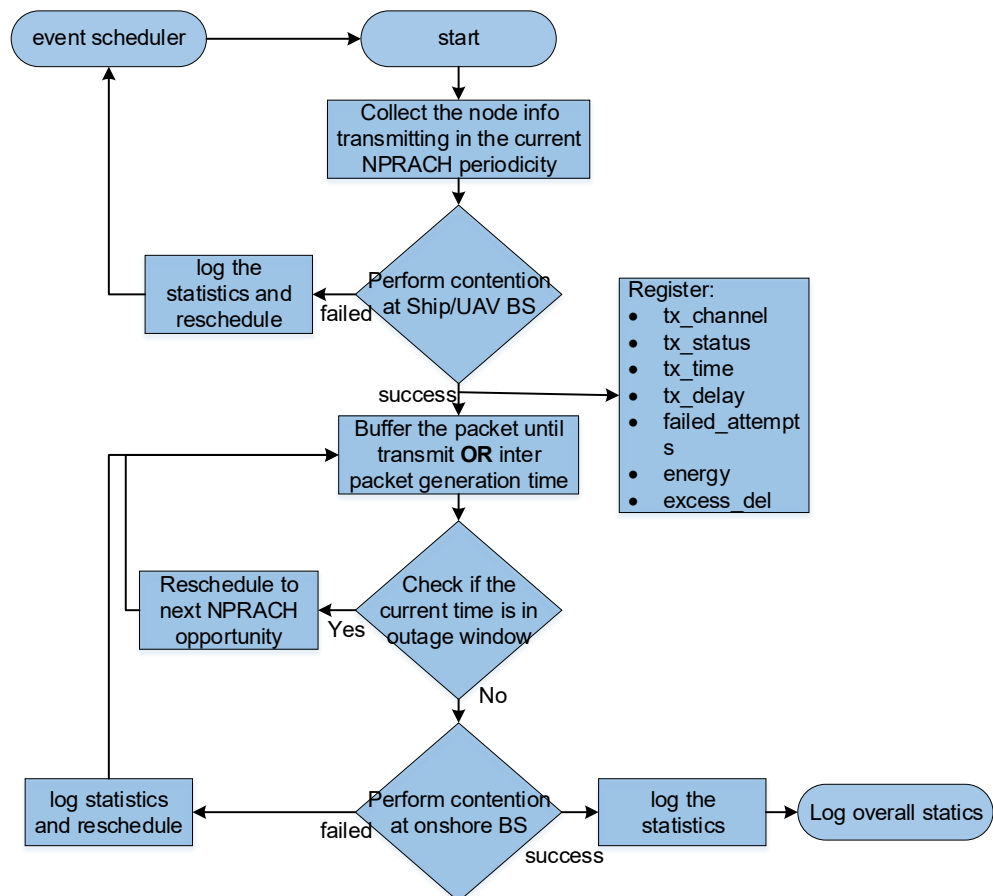

Figure 29. Ship BS and UAV implementation

4. NUMERICAL ASSESSMENT

In this section, the system input parameters to perform the analysis are listed. And the simulation results for all three implementation models of NB-IoT are elaborated in detailed. Each of the system metric tested against the given traffic load, base station presence, the preamble reattempts and explained the system response.

4.1 System input parameters

The system will be tested with the realistic scenario where the packet arrival intensity varies on the scale of 1.0 to 5.0. The RACH periodicity tested for this thesis is assumed to be 2.56 sec to mimic the real scenario. The coastal base station dynamics are assumed based on the information collected from The Republic of South Africa coastal region (*source: <http://www.cellmapper.net/>*). The following are the system input parameters set for assessing the performance of NB-IoT deployment for cargo ships.

Table 22. System input parameters summary

Parameter	Value
Number of sensors (N)	2000
Packet arrival intensity (λ)	Default value: 1 packet/h/sensor Variable: [0.1,...,5.0] packets/h/sensor
Mean connect duration ($Y1$)	Ref, Eq. 5 & Eq. 6
Mean outage duration ($Y2$)	Ref, Eq. 5 & Eq. 6
Excessive delay threshold (T_{delay})	Packet inter generation time
Max. RACH channels (C)	Default: 48 Options: {12, 24, 36, 48}
RACH periodicity (T_{RACH})	Default: 2560 ms Options: {40, 80, 160, 240, 320, 640, 1280, 2560}
Number of RACH repetitions (K)	Default: 128 Options: {1, 2, 4, 8, 16, 32, 64, 128}
Max. preamble repetitions (M)	Default: 10 [1,2,...,10]
Battery capacity (E)	1388 mAh [3.6 V]
Message frequency/day (F)	Default: 8 Variable: $\lambda * 24$
Packet size (S)	Default: 50 Bytes Variable: {50/ 100/ 200}
Width of the coast that can be reached from ship (a)	8 km

Parameter	Value
Distance between ship and coastal line (b)	10 km
NB-IoT BS coverage (r)	18 km
RV_uniform var(0, a) (L)	4 km
BS spatial intensity of (Λ)	Default: 0.1 Variable: [0.1, ..., 10]
Velocity of the ship (v)	37 km/h

4.2 Packet loss performance analysis

In this section, we assess the performance of the introduced and analyzed scenarios. As the considered service is not assumed to be of realtime nature and, in fact, heavily depends on the infrastructure availability on the coastal area in the most critical metric of interest is packet loss probability. We first start addressing the packet loss probability. We then proceed to investigate the mean packet delay at the air interface and finally study the mean sensor lifetime. The default system parameters are provided in Table 22.

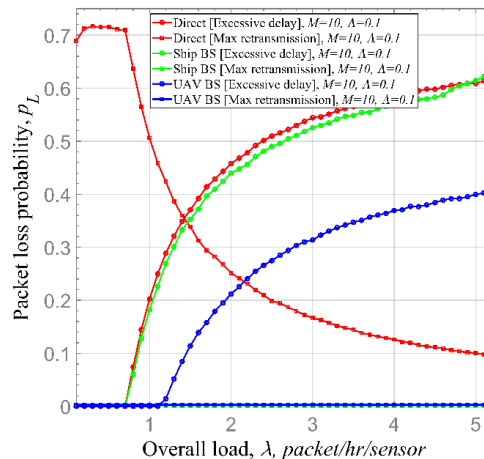

Figure 30. Packet losses over the offered load

Recall that in all the considered connectivity schemes, packet losses could happen as a result of both reaching the maximum number of preamble retransmission attempts or reaching the maximum packet lifetime. We first investigate how these components add to form the overall packet loss probability illustrated in Figure 30 for a maximum number of preamble retransmission attempts set to $M = 10$ and onshore density of NB-IoT BSs $\lambda_B = 0.1$ units/km². Analyzing the presented data, one may observe that there is a principle difference between loss components corresponding to direct access and Ship BS/UAV BS connectivity schemes.

Particularly, for all considered connectivity schemes the losses induced excessive delay of a packet is significant starting from around $\lambda = 0.1$ packets/h/sensor. The reasons are an irregularity in vessel coverage for a given choice of packet generation rate and density of onshore base stations. However, it is important to notice that although for direct access and ship base station scenarios the behavior of packet loss probability curves is quite close, the UAV-based connectivity scheme is characterized by milder losses. The underlying reason for this behavior is that UAV is positioned closer to the onshore improving the vessel coverage by increasing the temporal intensity of base stations that can be used for connectivity.

Analyzing the second component of the packet loss process shown in Figure 30, one may notice that losses caused by exceeding the number of preamble retransmission attempts are only experienced in the case of direct access scheme. For both ship BS and UAV BS connectivity schemes, these losses are negligible. This behavior is explained by two positive effects of Ship BS/ UAV BS schemes: (i) temporal spreading of packets transmission attempts at the sensor-Ship BS/ UAV BS NB-IoT interfaces, and (ii) multiplexing at the UAV/ Ship BS-Coastal BS NB-IoT interfaces.

Indeed, recalling that connectivity periods are interchanged with long outage periods for all three schemes, we observe that in the direct access scheme sensor become synchronized, that is, once vessel enters the coverage of a new onshore BS all the sensors start attempting to access the shared NB-IoT channel. Contrarily, in Ship BS/ UAV BS schemes sensors remain desynchronized while accessing NB-IoT channel drastically reducing the probability of exceeding the number of retransmission attempts.

Furthermore, once the data are transferred to the UAV BS/ Ship BS the joint the shared queue and transferred sequentially experiencing no competition for resources. Logically for direct access scheme, as losses caused by excessive delay increases we observe a decrease in losses caused by exceeding the number of preamble retransmission attempts. For small values of packet arrival intensity, we see that losses caused by a maximum number of retransmission attempts dominate. However, when intensity increases and becomes higher than approximately 1.5 packet/h/sensor the regime changes and more losses are experienced due to excessive delay.

As an intermediate conclusion, we may state that Ship BS/ UAV BS connectivity schemes efficiently deal with the problem of synchronization at the air interfaces leaving delay as the main factor affecting the packet loss probability. For direct access, scheme both factors play significant role.

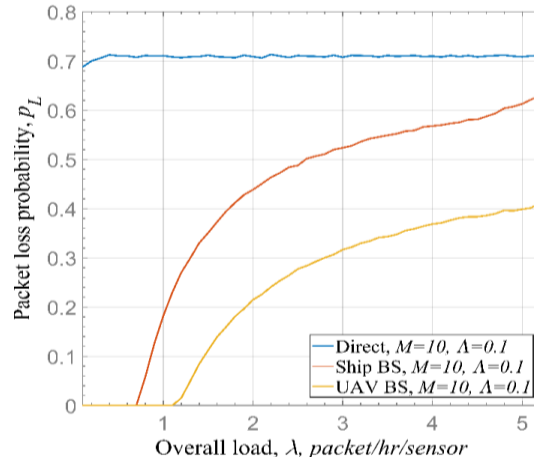

Figure 31. Packet loss probability as a function of offered traffic load

Aggregated packet loss is a key metric to analyze the system performance. Figure 31 shows aggregated packet loss probability as a function of system parameters. Analyzing the effect of the packet generation intensity, λ , we see that for direct access scheme it remains constant at approximately 0.7 for $M = 10$ and $\lambda B = 0.1$. Note that extremely high packet loss probability in light load conditions is explained by the fact that sensors access the medium in a synchronized way. When the arrival intensity increases, the mean duration between packet generation and, thus, the packet lifetime both decrease leading the system to excessive delay dominated regime.

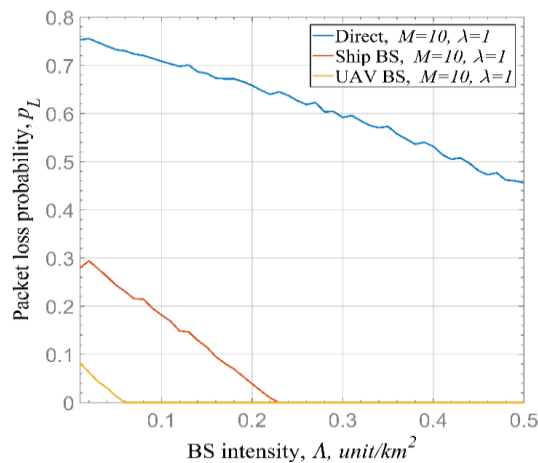

Figure 32. Packet loss probability as a function of BS intensity

For Ship BS/ UAV BS connectivity schemes, loss probability is negligibly low for small values of packet generation intensity and then drastically increases and λ becomes higher. In fact, the behavior of packet losses resembles that of the component induced by excessive delay shown in Figure 30. The effect of BS intensity on the packet loss probability is shown in Figure 32 for $M = 10$, $\lambda = 1$. Recall that the increase in the spatial density of BS increases the duration of connectivity intervals and reduces the outage

time. As a result, we see that for all considered connectivity strategies, the packet loss probability decreases.

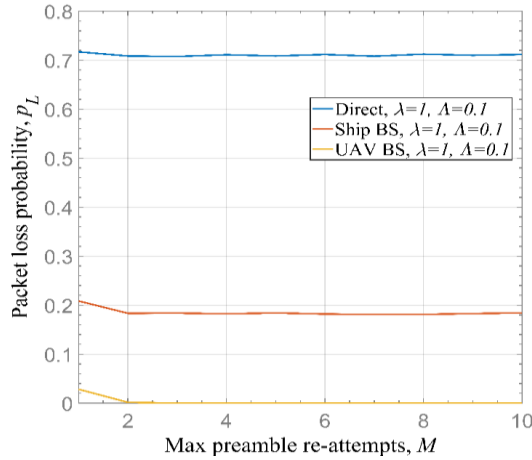

Figure 33. Packet loss probability as a function of preamble attempts

Observe that the trend is strictly linear. For direct access regime, even for extremely high BS densities on the order of 0.5 units/km², the packet loss probability is unacceptable for practical systems. At the same time using both UAV BS and Ship BS allows building an efficient service from the packet loss probability perspective for realistic ranges of BS intensities, i.e., smaller than 0.2 units/km². The use of UBS further improves performance as it allows to increase the duration of connectivity periods by allowing for more potential candidate base stations for connectivity.

4.3 Mean transmit delay analysis

The effect of preamble retransmission attempts is shown in Figure 33. Observe that for all schemes, a very limited performance improvement is observed when switching from $M = 1$ to $M = 2$. However, a further increase in M does not produce any substantial effect. The main reason is that packet losses in all considered schemes are mainly dominated by the connectivity process with onshore base stations.

Figure 32 and Figure 33 shows the effects of system parameters on the mean delay between the sensor and onshore BS. Analyzing the data illustrated in Figure 34, one may observe that the best performance is observed for direct access connectivity scheme. This interesting behavior is explained by the fact that in this scheme most of the packets arriving during the outage period are eventually lost as a result of two factors: relatively long outage periods and high contention at the beginning of the connectivity period.

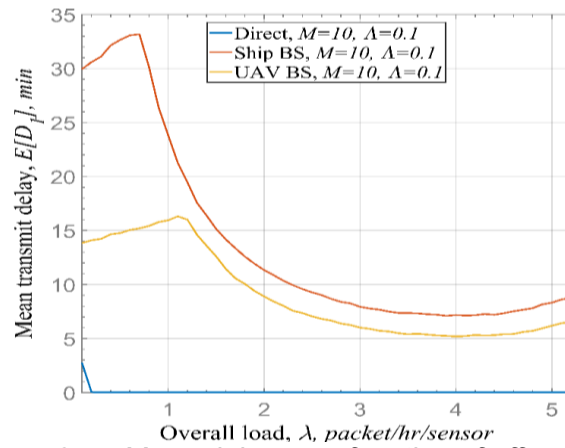

Figure 34. Mean delay as a function of offered traffic load

Since the presented delay is the mean delay conditioned on the successful packet delivery, the direct access scheme data on Figure 34 reflect only those situation when a packet arrives in the middle or close to the end of the connectivity interval. In these time periods, the system is underloaded and arriving packets are in most cases successfully delivered to the onshore BS experiencing small delays. Note that this is dominating factor for all considered dependencies for direct access scheme in Figure 34 and Figure 35.

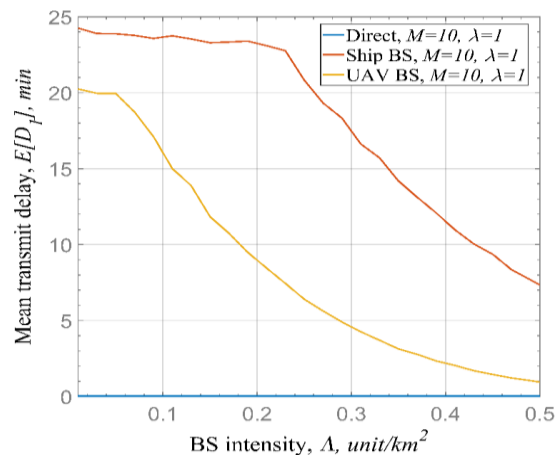

Figure 35. Mean delay as a function of BS intensity

Addressing Ship BS /UAV BS schemes, one may observe very specific behavior of the mean delay as a function on the packet arrival intensity in Figure 34. Particularly, for both schemes the mean delay first increases and then, starting from a certain value of λ , starts to decreases. The underlying reason for this complex behavior is that, up to the turning point, the system experiences relatively low loss probability tolerating outage intervals. Increasing the arrival intensity in these intervals will lead to conventional behavior of the stable system – the mean delays increases. However, when a certain limit of the packet arrival intensity is reached, losses start to accumulate, see Figure 31, and the mean delay starts to drastically decrease.

The effect of the density of onshore BS on the mean delay is illustrated in Figure 34. Analyzing the presented data, one may observe that for Ship BS/ UAV BS schemes the mean delay behavior is specific. Particularly, it remains almost constant for a certain density of BSs and then starts to decrease significantly. This is explained by the fact that up to this turning point the most of the outage intervals are large enough to induced losses as a result of the limited packet lifetime of $1/\lambda$ s.

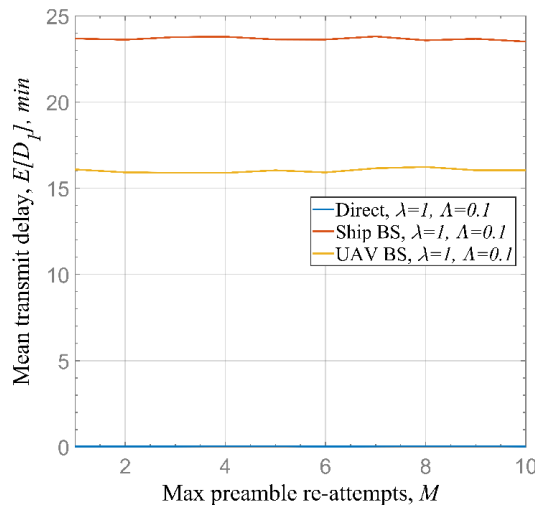

Figure 36. Mean delay as a function of preamble attempts

Once BS intensity is such that the mean outage interval becomes smaller than $1/\lambda$ not only packet loss probability reduces but also mean delay. Finally, similarly to packet loss probability, no noticeable effect of the number of preamble retransmission attempts on the mean delay is observed.

4.4 Mean sensor lifespan analysis

We finally proceed analyzing the effect of system parameters on the sensor lifetime, see Figure 37 and Figure 38. Recall that to calculate these values we have assumed a typical coin cell battery of 20 mAh. First, we note that the sensor lifetime for Ship BS and UAV BS schemes coincides as they rely on the relaying approach. Secondly, Ship BS/ UAV BS schemes are much efficient in terms of sensor lifetime compared to simple direct access scheme.

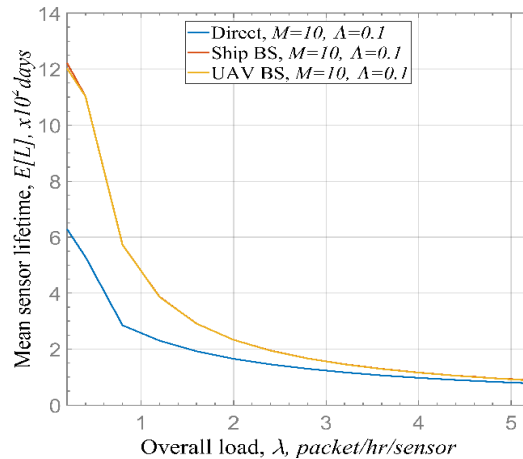

Figure 37. Mean sensor lifetime as a function of offered traffic load

The underlying reason is that for these schemes transmissions at the sensor-to-Ship BS/ UAV BS interfaces are desynchronized implying that less preamble retransmission attempts are required for packet delivery. Analyzing the dependence on the packet arrival rate, illustrated in Figure 37 one may deduce that for all three considered connectivity schemes the sensor lifetime decreases. Nevertheless, even for significantly high arrival intensity, for example 2 - 3 packets per hours per sensor, the mean sensor lifetime is approximately 200 days. When at most 1 packet is generated per hour Ship BS and UAV BS schemes may lead to lifetimes of high than a year.

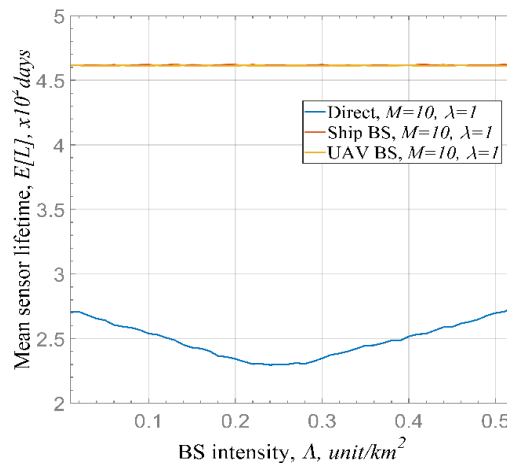

Figure 38. Mean sensor lifetime as a function of BS intensity

It is important to observe that the density of onshore BSs and a maximum number of re-transmission attempts do not produce any noticeable effects on the sensor lifetime of Ship BS/ UAV BS connectivity schemes. The underlying reason for this behavior is that due to relatively long outage intervals in the considered connectivity schemes, for practical system parameters, sensors spend most of the time in the active regime. Particularly, the increase in lifetime is only observed for non-practical intensities of BSs. This is also the reason why the lifetime is insensitive to retransmission attempts, i.e., in spite

the energy spent for actual transmission is significantly higher compared to that needed in the ready state, the fraction of time sensor actually transmit is insignificant.

The behavior of sensor lifetime is more complex, see Figure 38 and Figure 39. Particularly, when BS density increases the lifetime first decreases then reaches a turning point when a further increase in λB leads to higher lifetime. The reason is that the increase in λB decrease the duration of outage intervals and more sensors get opportunities for data transmission. However, due to synchronization effect, it these transmissions in most cases are unsuccessful consuming maximum possible amount of power in a sensor duty cycle. However, when the density of BS becomes greater than a certain value the longer connectivity intervals start to positively affect sensor lifetime.

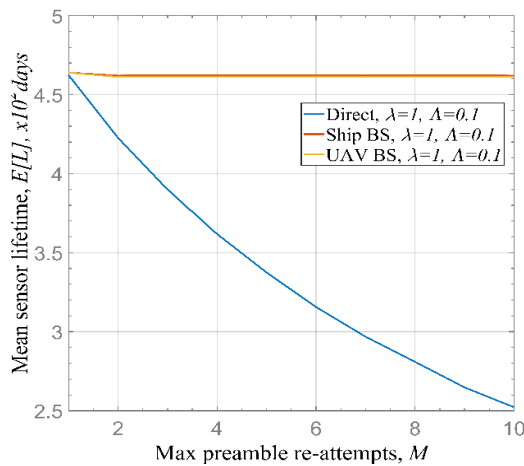

Figure 39. Mean sensor lifetime as a function of preamble attempts

Particularly, the packet loss probability and mean delay both decrease as seen in Figure 33 and Figure 36, implying less energy is spent on average for single packet transmission. Finally, the reason for decreasing sensor lifetime in response to increasing the maximum number of preamble retransmission attempts is that in this scheme most of the packets are unsuccessfully delivered irrespective of the number of attempts thus requiring the maximum amount of energy during a single sensor duty cycle.

5. CONCLUSION

In this section, the overall findings are described with reasoning. How the packet loss, sensor lifetime, mean packet delay get affected in each implementation is summarized to draw the conclusions. Also, the future scope of work for this thesis is briefed.

After performing the simulations based on realistic base station density information from the Republic of South Africa (RSA) region as a sample, the following conclusions are drawn:

- The packet loss will be too high with the given coverage and intensity of packet arrival for the direct access implementation. Except the least mean transmit delay during the onshore LTE coverage, as a system direct access implementation has yielded poor performance. The relay base station implementation has the edge due to the buffer mechanism and high availability to the sensors at all time.
- Base station density is the key parameter for the system's finest performance. While the density of base stations is quite low, the radio resource bottleneck results in packet loss and increased delay in transmission of data. The mean packet transmit delay at sensor would be nominal when the base station is always available to the sensor, thus long life to the IoT sensor. The mean sensor battery life will yield high while the sampling is 2 or 3 packets per day. While a local base station is onboard, the IoT sensor may last for 10+ years, as there is no need for repetitions and retransmissions.
- The max number of preamble attempt in CE level does not affect the overall successful transmission, but only a measure to limit the unnecessary battery draining. The maximum number of preamble re-attempts would show an effect on the sensor lifetime. Since the transmission of a packet requires high energy compared to that of reception or idle state, the battery gets drained with an increase in the number of preamble reattempts. Contention at the access network is inversely proportional to the system resource utilization.
- The coverage area will be increased to 80 km using UAV base station in the sea, considering the antenna height at a minimum of 30 m. It can further be increased if the sensor transmit power is increased. The data transmission rate also improved in this method, as it forms clustered network architecture to avoid congestion.

Future scope of work for the system

The following research work will be the roadmap for this thesis.

- Clustering the vessels with the available long distance communication protocols to relay the sensor information to coastal LTE network up to few hundreds of kilometers in the sea.
- In the context of increased maritime trade, buoy-based access points can be deployed in the sea across the coast where most of the vessels sail. A comprehensive study has to be performed to extend the IoT services in the sea.
- Although there are ongoing trials for balloon-based internet services in lands, it is also an area where the offshore ships can make use of such solution for the future use cases.

REFERENCES

- [1] 3GPP TS 36.306 V13.3.0, 3rd Generation Partnership Project; Technical Specification Group Radio Access Network; Evolved Universal Terrestrial Radio Access (E-UTRA); User Equipment (UE) radio access capabilities (Release 13), Sept - 2016.
- [2] 3GPP TR 45.820 V2.1.0, 3rd Generation Partnership Project; Technical Specification Group GSM/EDGE Radio Access Network; Cellular System Support for Ultra Low Complexity and Low Throughput Internet of Things; (Release 13), Aug-2015.
- [3] 3GPP TS 36.213 V14.2.0, LTE; Evolved Universal Terrestrial Radio Access (E-UTRA); Physical layer procedures (Release 14), Apr-2017.
- [4] 3GPP TS 36.321 V13.6.0, LTE; Evolved Universal Terrestrial Radio Access (E-UTRA); Medium Access Control (MAC) protocol specification (Release 13), Jun-2017.
- [5] 3GPP TS 23.682 V13.5.0, 3rd Generation Partnership Project; Technical Specification Group Services and System Aspects; Architecture enhancements to facilitate communications with packet data networks and applications (Release 13), Mar-2016.
- [6] LPWA technologies: Separating Fact from Fiction; White paper; March 2018; <https://www.sierrawireless.com/resources/white-paper/lpwa-fact-or-fiction/>
- [7] Narrowband-IoT: Pushing the boundaries of IoT; <https://www.vodafone.com/business/news-and-insights/white-paper/narrowband-iot-pushing-the-boundaries-of-iot>
- [8] 3GPP TS 36.211 V 14.2.0, LTE; Evolved Universal Terrestrial Radio Access (E-UTRA); Physical channels and Modulation (Release 14), Apr-2017.
- [9] M2M traffic growth: <https://www.cisco.com/c/en/us/solutions/collateral/service-provider/visual-networking-index-vni/white-paper-c11-741490.html>
- [10] Ship intelligence – Pushing the boundaries of technology; <http://www.rolls-royce.com/products-and-services/marine/services/ship-intelligence/remote-and-autonomous-operations.aspx>
- [11] Begishev, V., Petrov, V., Samuylov, A., Moltchanov, D., Andreev, S., Koucheryavy, Y. & Samouylov, K. (2018). Resource allocation and sharing for heterogeneous data collection over conventional 3GPP LTE and emerging NB-IoT technologies, Computer Communications, Vol. 120 pp. 93-101. <https://www.sciencedirect.com/science/article/pii/S0140366417306801>.
- [12] Chafii, M., Bader, F. & Palicot, J. (Apr 2018). Enhancing coverage in narrow band-IoT using machine learning, 2018 IEEE Wireless Communications and Networking Conference (WCNC), France, IEEE, pp. 1-6.
- [13] Changsheng Yu, Li Yu, Yuan Wu, Yanfei He & Qun Lu (2017). Uplink Scheduling and Link Adaptation for Narrowband Internet of Things Systems, IEEE Access, Vol. 5 pp. 1724-1734. <https://ieeexplore.ieee.org/document/7842562>.

- [14] Chen, M., Miao, Y., Hao, Y. & Hwang, K. (2017). Narrow Band Internet of Things, IEEE Access, Vol. 5 pp. 20557-20577. <https://ieeexplore.ieee.org/document/8038776>.
- [15] Jiming Chen, Kang Hu, Qi Wang, Yuyi Sun, Zhiguo Shi & Shibo He (2017). Narrowband Internet of Things: Implementations and Applications, IEEE Internet of Things Journal, Vol. 4(6), pp. 2309-2314. <https://ieeexplore.ieee.org/document/8076876>.
- [16] Joseph, O.J. (2018). Ultra-Narrowband Internet-of-Things Technologies, Available: <http://dSPACE.cc.tut.fi/dpub/handle/123456789/26178>.
- [17] Karakostas, B. (2017). Towards autonomous IoT logistics objects, The internet of things in the modern business environment, pp. 210-222. <http://www.econis.eu/PPN-SET?PPN=892929790>.
- [18] Li, S., Xu, L.D. & Zhao, S. (2018). 5G Internet of Things: A survey, Journal of Industrial Information Integration, Vol. 10 pp. 1-9. <https://www.sciencedirect.com/science/article/pii/S2452414X18300037>.
- [19] Liang Chen, Thombre, S., Jarvinen, K., Lohan, E.S., Alen-Savikko, A., Leppakoski, H., Bhuiyan, M.Z.H., Bu-Pasha, S., Ferrara, G.N., Honkala, S., Lindqvist, J., Ruotsalainen, L., Korpisaari, P. & Kuusniemi, H. (2017). Robustness, Security and Privacy in Location-Based Services for Future IoT: A Survey, IEEE Access, Vol. 5 pp. 8956-8977. <https://ieeexplore.ieee.org/document/7903611>.
- [20] Linghe Kong, Khan, M.K., Fan Wu, Guihai Chen & Peng Zeng (2017). Millimeter-Wave Wireless Communications for IoT-Cloud Supported Autonomous Vehicles: Overview, Design, and Challenges, IEEE Communications Magazine, Vol. 55(1), pp. 62-68. <https://ieeexplore.ieee.org/document/7823339>.
- [21] Mahjoubi, A., Mazri, T. & Hmina, N. (Oct 25, 2017). First Africa and Morocco NB-IoT experimental results and deployment scenario, Proceedings of the Mediterranean Symposium on smart city application, ACM, pp. 1-6. <https://dl.acm.org/citation.cfm?id=3175641>
- [22] Malik, H., Alam, M.M., Moullec, Y.L. & Kuusik, A. (2018). NarrowBand-IoT Performance Analysis for Healthcare Applications, Procedia Computer Science, Vol. 130 pp. 1077-1083. <https://www.sciencedirect.com/science/article/pii/S1877050918305192>.
- [23] Miao, Y., Tian, Y., Cheng, J., Hossain, M.S. & Ghoneim, A. (2018). RADB: Random Access with Differentiated Barring for Latency-Constrained Applications in NB-IoT Network, Wireless Communications and Mobile Computing, Vol. 2018 pp. 1-9. https://www.openaire.eu/search/publication?articleId=dedup_wf_001::f0f69f1a4f5720294a1e8dfb3d7b3476.
- [24] NB-IoT for D2D-Enhanced Content Uploading with Social Trustworthiness in 5G Systems (2017). in: Future Internet, MDPI AG, Basel, pp. 31.
- [25] N.P.G. Bhavani, P. Vaishnavi & K. Sujatha (Jan 1, 2017). Off-shore wind power as a pillar of energy transmission using IOT (OSWPETIOT), IEEE Conference Proceedings. <http://ieeexplore.ieee.org/stamp/stamp.jsp?tp=&arnumber=8389901>

- [26] Nan Jiang, Yansha Deng, Condoluci, M., Weisi Guo, Nallanathan, A. & Dohler, M. (2018). RACH Preamble Repetition in NB-IoT Network, *IEEE Communications Letters*, Vol. 22(6), pp. 1244-1247. <https://ieeexplore.ieee.org/document/8258982>.
- [27] Petrov, V., Samuylov, A., Begishev, V., Moltchanov, D., Andreev, S., Samouylov, K. & Koucheryavy, Y. (2018). Vehicle-Based Relay Assistance for Opportunistic Crowdsensing Over Narrowband IoT (NB-IoT), *IEEE Internet of Things Journal*, Vol. 5(5), pp. 3710-3723. <https://ieeexplore.ieee.org/document/7857676>.
- [28] Philip, B.V., Alpcan, T., Jin, J. & Palaniswami, M. (2018). Distributed Real-Time IoT for Autonomous Vehicles, *IEEE Transactions on Industrial Informatics*, pp. 1. <https://ieeexplore.ieee.org/document/8501581>.
- [29] Ratasuk, R., Vejlgard, B., Mangalvedhe, N. & Ghosh, A. (Apr 2016). NB-IoT system for M2M communication, 2016 IEEE Wireless Communications and Networking Conference, IEEE, pp. 1-5.
- [30] R. Boisguene, S.-C. Tseng, C.-W. Huang, and P. Lin, "A survey on NB-IoT downlink scheduling: Issues and potential solutions," in Proc. IWCMC, Valencia, Spain, Jun. 2017, pp. 547–551.
- [31] Sahoo, B.P.S., Chou, C., Weng, C. & Wei, H. (2019). Enabling Millimeter-Wave 5G Networks for Massive IoT Applications: A Closer Look at the Issues Impacting Millimeter-Waves in Consumer Devices Under the 5G Framework, *IEEE Consumer Electronics Magazine*, Vol. 8(1), pp. 49-54. <https://ieeexplore.ieee.org/document/8570917>.
- [32] Internet of Things: Architectures, Protocols, and Applications (2017). in: *Journal of Electrical and Computer Engineering*, Hindawi Limited, New York, pp. 1-25.
- [33] Shariatmadari, H., Ratasuk, R., Iraj, S., Laya, A., Taleb, T., Jäntti, R. & Ghosh, A. (2015). Machine-type communications: current status and future perspectives toward 5G systems, *IEEE Communications Magazine*, Vol. 53(9), pp. 10-17. <https://ieeexplore.ieee.org/document/7263367>.
- [34] Vuran, M.C., Salam, A., Wong, R. & Irmak, S. (2018). Internet of underground things in precision agriculture: Architecture and technology aspects, *Ad Hoc Networks*, Vol. 81 pp. 160-173. <https://www.sciencedirect.com/science/article/pii/S1570870518305067>.
- [35] Wang, Y.-E., Xingqin Lin, Adhikary, A., Grovlen, A., Yutao Sui, Blankenship, Y., Bergman, J. & Razaghi, H.S. (2017). A Primer on 3GPP Narrowband Internet of Things, *IEEE Communications Magazine*, Vol. 55(3), pp. 117-123. <https://ieeexplore.ieee.org/document/7876968>.
- [36] Review of Maritime Transport 2018, UNCTAD, pp-45. https://unctad.org/en/Publication-Library/rmt2018_en.pdf
- [37] 5G Americas: LTE and 5G Technologies Enabling the Internet of Things December 2016, pp-23, 31. www.5gamericas.org/files/3514/8121/4832/Enabling_IoT_WP_12.8.16_FINAL.pdf