



# Network Virtualization Technologies and Challenges

Cheick A. Konate, Joshua Oiseomaje, Mohammed Alyas, Scott Ivan, Zainab Altaweel  
 Advisor Dr. Omar Abuzagheh  
 Department of Computer Engineering,  
 University of Bridgeport, Bridgeport, CT

## Introduction

Network virtualization is dividing or combining hardware resources that the users can make use of, and every user has his own specific perspective, these resources can be nodes or links. Network virtualization became one of the most important technologies recently, The architecture and base platform of a NV hardware is crucially looked at for its importance in implementing an advanced consumer service. It also an important part is to follow the technical requirements when implementing the system.

## Why Network Virtualization?

virtualization could help the networks to provide better QoS and user experience. Meanwhile cost and energy usage is reduced because the resources are distributed more efficiently  
 There is a growing need for new optimization techniques in network virtualization due to the growth of server farms and cloud computing. High performance network connections are key to the evolution of network virtualization because of the exponential growth of I/O throughput on a daily basis.

## Network Virtualization Technologies

### Basic network components virtualization

- ⑩ Network Interface Cards (NICs) a single NIC can be shared across multiple instances of the virtual operating system.
- ⑩ Router virtualization technologies, like Routers in Virtual OS

### Link Virtualization

- ⑩ Like channel Multiplexing, where the link is divided among multiple transmissions simultaneously.

### Data Path Virtualization

- ⑩ The data is manipulated rather than the link itself. It can be achieved using:
- ⑩ Tags or labels for each packet such as VLANs and MPLS.
- ⑩ Tunneling.

## Virtual networks that uses the previous Technologies

- ❖ Overlay network: a new network can be implemented using an existing network infrastructure.
- ❖ Virtual Private Networks (VPN)
- ❖ Virtual Sharing Networks (VSN).

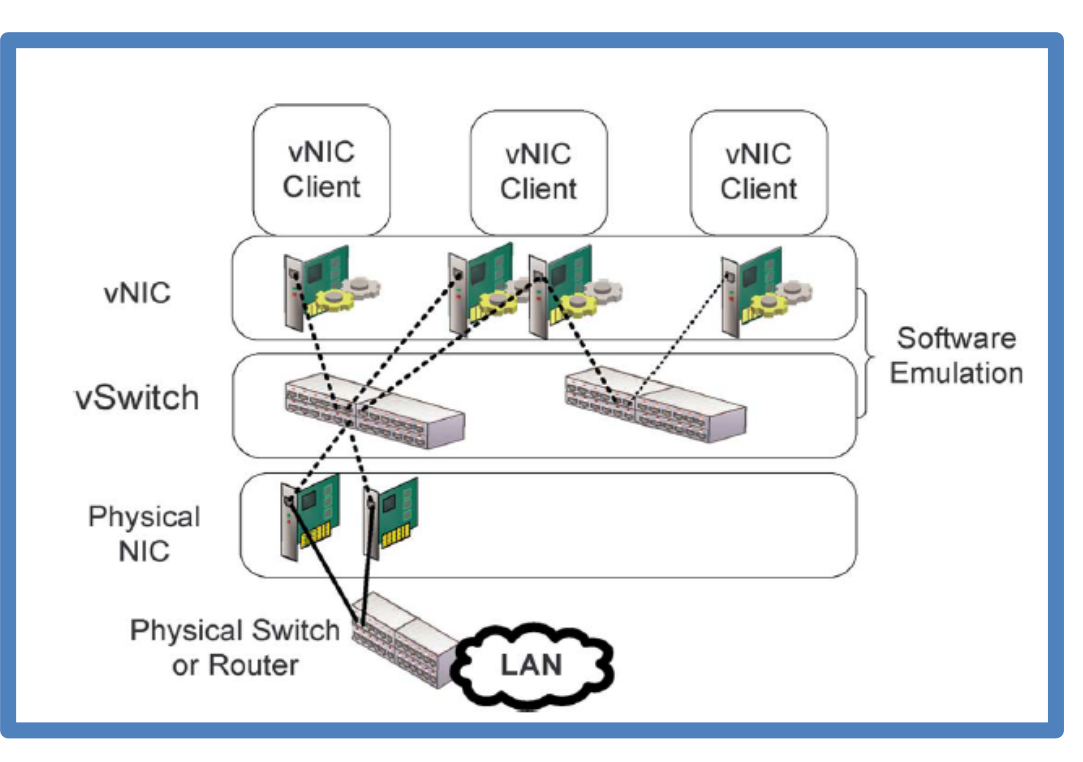

General NIC Virtualization Architecture

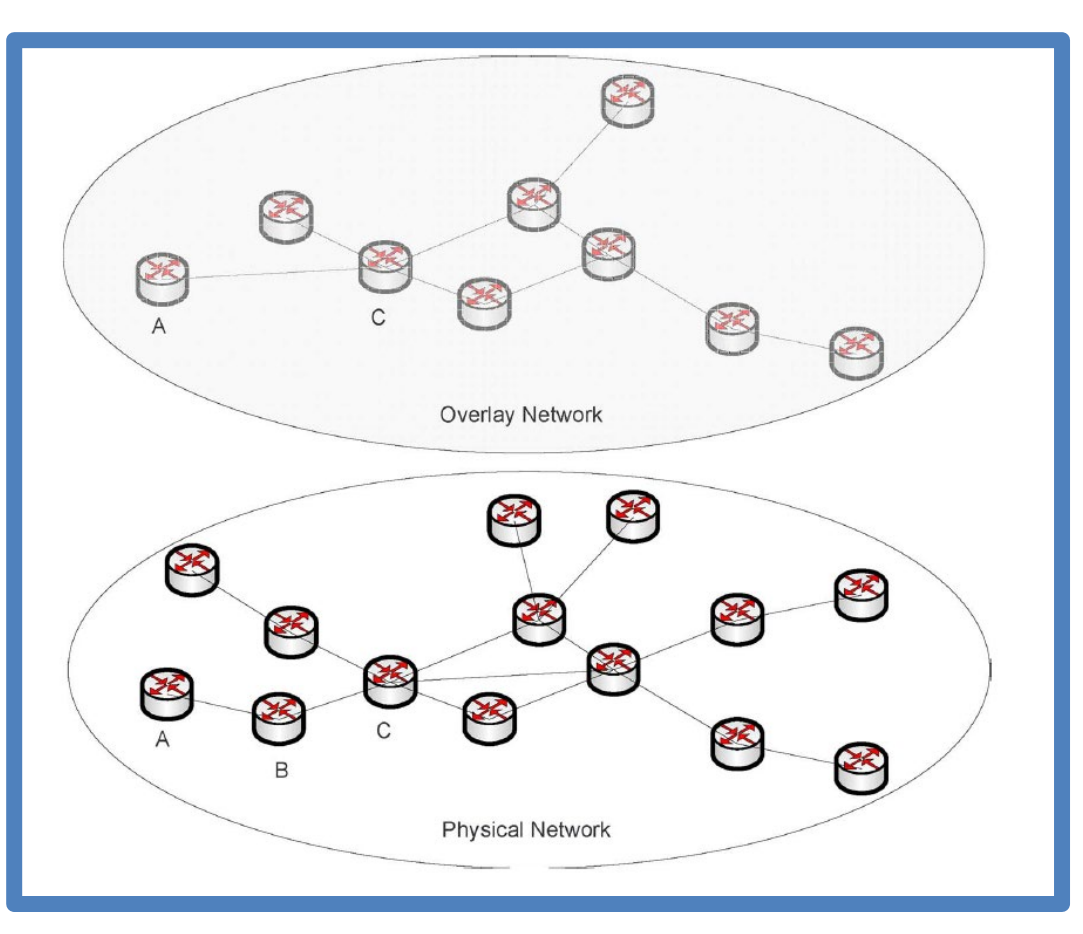

Overlay Network

## VNF Technical Requirements

The virtual network functioning needs to be design with split network load, distributed in numerous VMs, as considering the latency effects too. It has to gain the ability of collecting the information of the network performance, and other facts as the virtual switch. In designing it, the maximum performance level that we can achieve must be considered, in accordance to the Programmable hardware.

## VNF Security

In installing VNF, the operator has to make sure it network features and security is not disturbed. As it can be disadvantaged of having a non-owned data run through the owner system. Another threat to be avoided, is that router of the VM that share its physical systems that present complexity. Another security benefit that includes using a digital network is the capability to have digital firewalls disbursed in the course of the data center. Instead, security was the major factor.

## VNF Reliability

VNF is highly reliable compared to other network technologies. It need a software resilience adapted, to prevent error. As traffic also should be dealt with automatically. It should be able to transfer from a hardware to another without affecting the service. It must avoid the high rate of packet loss, and call drop rate.

## Optimization Technologies

Different techniques and technologies used for optimizing network virtualization include:

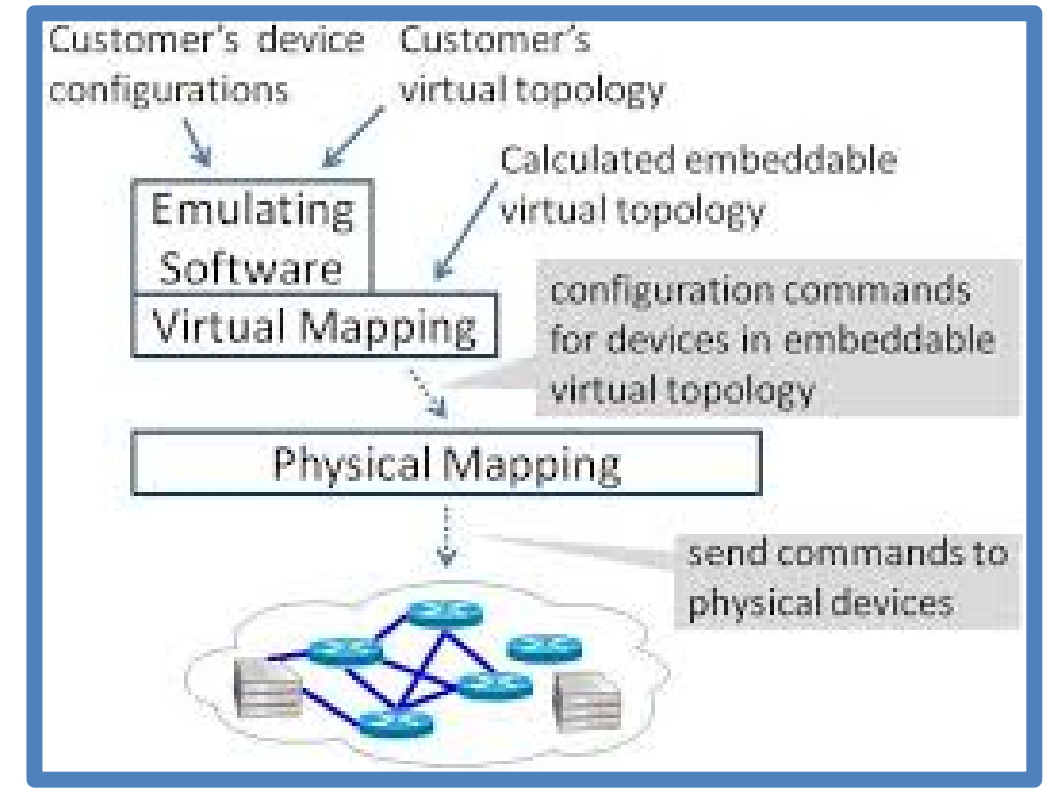
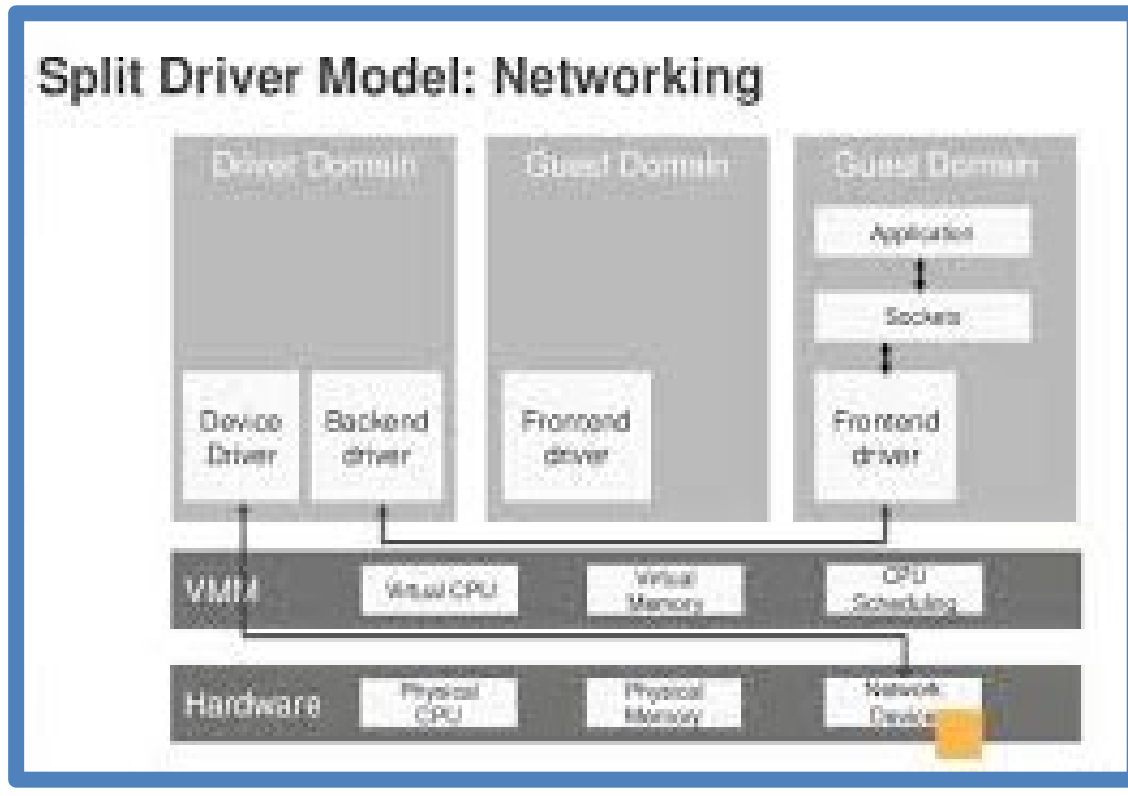
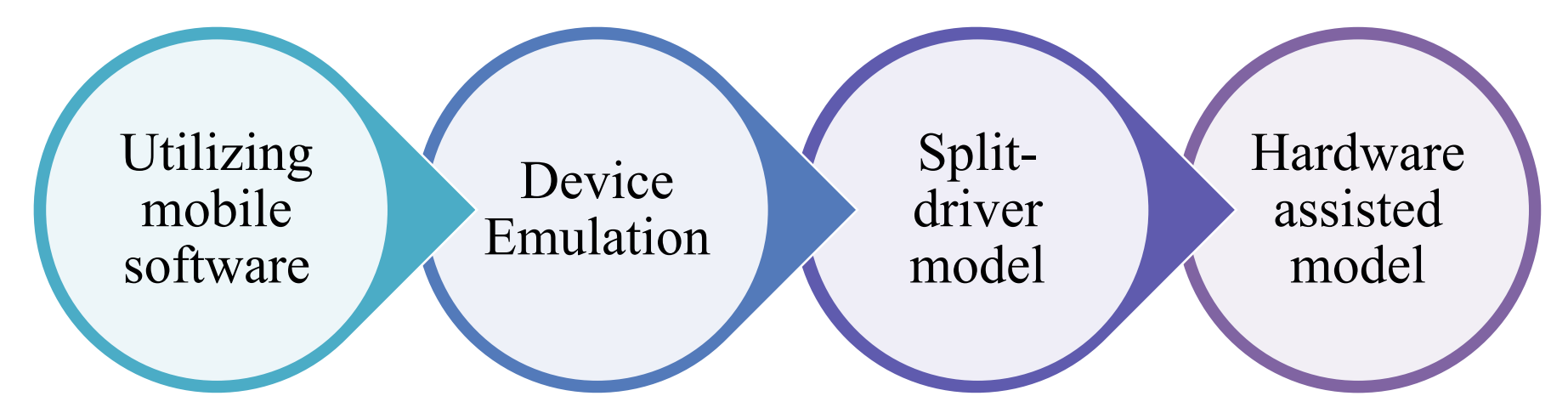

## NV Application in Cloud Computing

Cloud computing infrastructures will likely be a key component of future Internet architectures, owing to the many advantages of server and network virtualization, especially considering the emerging Network Function Virtualization and Software Defined Networking technologies. The cloud infrastructure will then determine the performance of the networking environment.

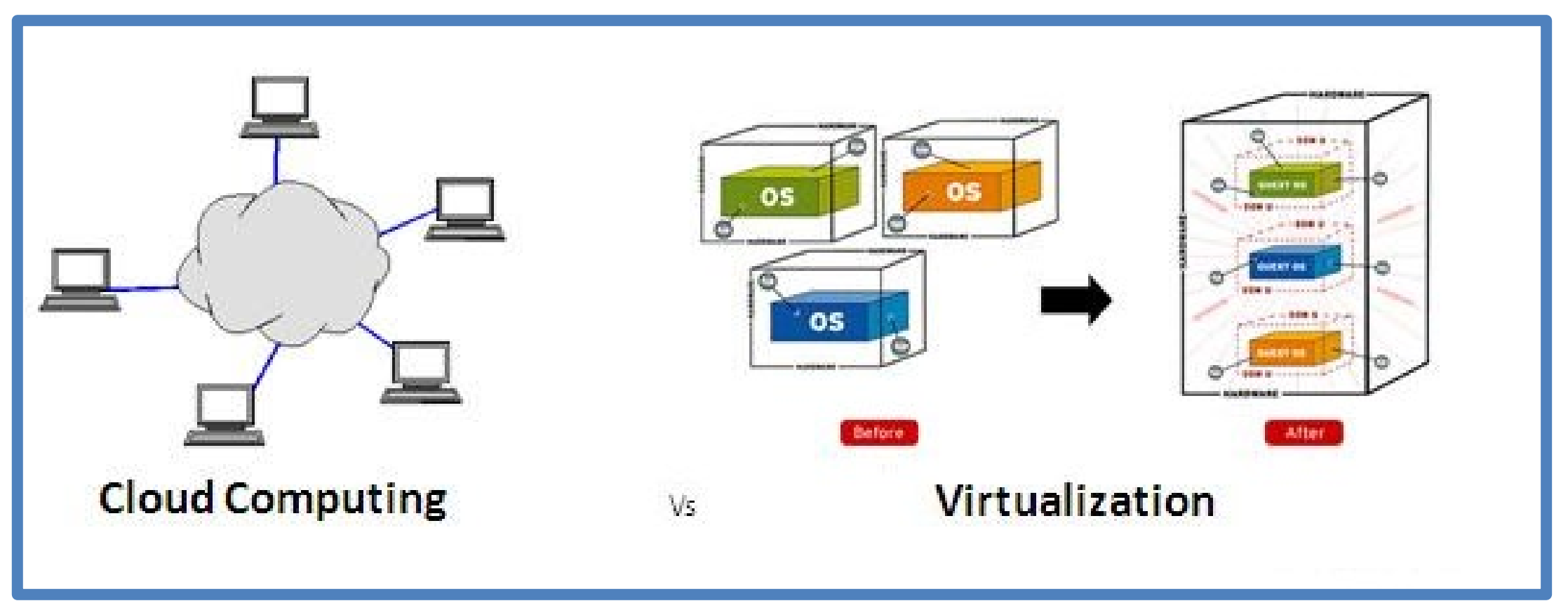

## Conclusion

In this research we have conducted a thorough study in network virtualization technologies, applications and challenges. We studied the standards of virtualization in computer networks, the capability to run unique logical network environments from a pooled set of physical network devices, all with automation supplied by way of software. Network virtualization is proposed to be an integral part of next-generation networking paradigm, provides flexibility, reduce cost, promotes diversity and promises security and increased manageability

## References

1. Zhou FF, Ma RH, Li J et al. Optimizations for high performance network virtualization. JOURNAL OF COMPUTER SCIENCE AND TECHNOLOGY 31(1): 107–116 Jan. 2016. DOI 10.1007/s11390-016-1614-x
2. Wang, A., Iyer, M., Dutta, R., Rouskas, G. N., & Baldine, I. (2013). Network Virtualization: Technologies, Perspectives, and Frontiers. Journal of Lightwave Technology, 31(4), 523-537. doi:10.1109/jlt.2012.2213796
3. Jain, R., & Paul, S. (2013). Network virtualization and software defined networking for cloud computing: A survey. IEEE Communications Magazine, 51(11), 24-31. doi:10.1109/mcom.2013.6658648
4. Xilouris, G., Kourtis, M., Mcgrath, M. J., Riccobene, V., Petralia, G., Markakis, E., . . . Bonnet, J. (2015). T-NOVA: Network functions as-a-service over virtualised infrastructures. 2015 IEEE Conference on Network Function Virtualization and Software Defined Network (NFV-SDN). doi:10.1109/nfv-sdn.2015.7387394
5. Bo Han, Vijay Gopalakrishnan, Lusheng Ji, and Seungjoon Lee (2015). Network Function Virtualization: Challenges and Opportunities for Innovations. HAN\_LAYOUT\_Author Page 90.