



Engineering
PERIODICALS
US000

University of Glasgow
DEPARTMENT OF
**AEROSPACE
ENGINEERING**



Sail Structural Analysis
Sabrina Maria Malpede

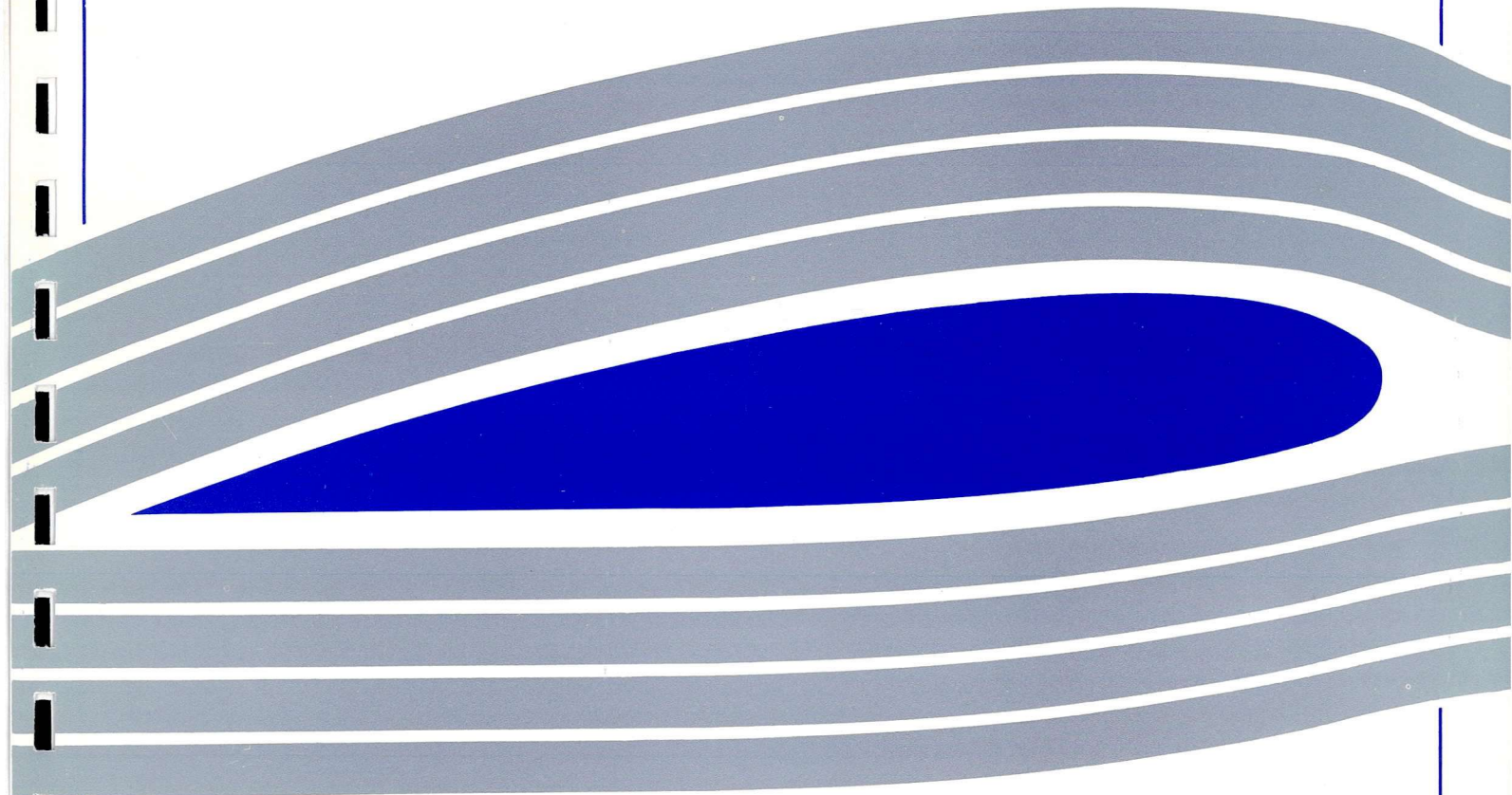

G.U. Aero Report No. 9820

Sail Structural Analysis

Sabrina Maria Malpede

Department of Aerospace Engineering

University of Glasgow

June 1998

Abstract

While a sailboat is sailing, aerodynamic and hydrodynamic forces are developed due to the interaction between the air flow and the sail plane and between the waves and hull, respectively. Because the sail is so flexible that it can easily be deformed by aerodynamic pressure the aeroelasticity is essential in this context. In fact, on one side the flow around the sail depends upon its shape, but, on the other side, the pressure resulting from the flow determines the shape of the sail. This means that the dynamic and the aerodynamic analysis have to be solved simultaneously.

The aim of the present report is to develop the structure analysis of a simple sail configuration composed of a jib, mast and its rig. For each element the structural analysis is developed using the finite element method. The analysis for the sails and the wires of the rig will be non linear due to their large displacements, while for the mast the linear structural analysis will be considered enough

CONTENTS

1. Introduction

2. Forces on the sailing yacht

3. The Structural Analysis

3.1. Non-linear structural analysis

3.2. The Sail

3.2.1. Geometry

3.2.2. Properties

3.2.3. Material

3.2.4. Construction methods

3.2.5. Trim

3.2.6. Finite element formulation for the sail: membrane element

3.3. The mast and the rig

3.3.1. Finite element formulation for the mast: beam element

3.3.2. Finite element formulation for the wires: cable element

4. Conclusion

References

1.Introduction

The aim of the present report is to write about the structural analysis of a sail configuration. It will be considered a simple configuration composed of a jib , mast and its rig.

The shape of a lifting surface, like a sail, [7], has significant effects on the lift and the drag generated. These effects are stronger in a yacht sail, because the sail is so flexible that it can easily be deformed by aerodynamic pressure. Hence aeroelasticity is essential in this context. In fact, on one side the flow around the sail depends upon its shape, but, on the other side, the pressure resulting from the flow determines the shape of the sail. This means that the dynamic and the aerodynamic analysis have to be solved simultaneously.

A first way to solve this aeroelastic problem is to subdivide it into two parts. On the one hand is the need to calculate the equilibrium shape under a given pressure. On the other hand, the necessary to compute the pressure distribution for a given sail shape. To solve the first problem, it is appropriate to give initial condition to the structural sail problem for a simple sail configuration.

A standard sailing yacht configuration, [18], consists of a hull on which there are the keel, rudder and sometimes a trim-tab. Several shapes are used for these three components which can be employed on different configurations: they can be united in one piece or divided into the keel-rudder and trim tab. It depends on the choices made by yacht designers . However, in all the configurations, they are like symmetric wings: the surface of the keel is bigger than the surface of the rudder and in order to generate the hydrodynamic force the keel needs an angle of attack (leeway angle).

There are three sails on a yacht, usually: the mainsail, the jib (or genoa) and the spinnaker. The mainsail and the jib have triangular form but, while the jib stretches forward from the mast, the mainsail stretches aft. The mast provides the support for the sails. The spinnaker is the biggest sail and it is more versatile due to the non occurability of its surface

In the next section, sails are described in more detail. The first part will consider the forces involved when a yacht is sailing, followed by a section about the structural analysis.

2.Forces on a sailing yacht

A monohull sailboat is considered sailing to windward in smooth water, [8]. Figure 1 shows the forces acting on the yacht: the aerodynamic forces due to the flow of wind on the sails and the hydrodynamic forces due to the interaction between the waves and the hull.

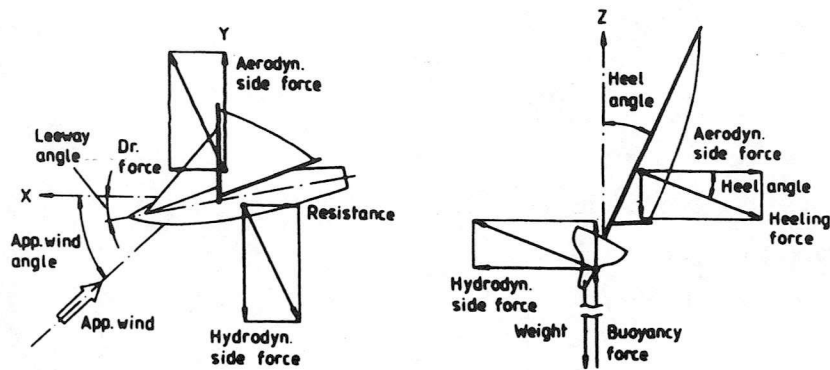

Figure 1: Forces on the yacht

A sail is like an aeroplane wing: the air travels faster on the leeward side than on the windward, and the resulting difference in pressure produces the aerodynamic forces. The *aerodynamic forces* on the sails (F_S) consist of a lift component (perpendicular to the apparent wind direction), and a drag component (parallel to the apparent wind direction). These sail forces can also be resolved into a driving force or thrust (T) parallel to the course sailed, and a heeling force (H) (or more precisely heeling moment) perpendicular to the course sailed.

The *hydrodynamic forces* (F_H) acting on the hull, keel, and rudder consist of a side force (S) perpendicular to the course sailed, and a drag force (D), parallel to the course sailed.

For the boat, to remain at a constant speed, it must be true

$$T = D$$

and to remain at a steady angle of heel, the heeling moment produced by the side force and the heeling force must be cancelled by a moment equal and opposite created by the buoyancy force (B) and the total weight of the boat plus the crew (W). This means that the following conditions must be satisfied:

$$B = W; \quad H = S; \quad W \cdot \overline{GZ} = H \cdot h;^1$$

Therefore, a keelboat must have a heel because the buoyancy forces B and the weight W must be out of the same line, so they can produce the righting moment.

Because the hydrodynamic forces acting on the boat depend on speed, leeway angle, and heel angle, and the aerodynamic forces depend on wind speed, apparent wind angle, heel angle, sail area and sail shape, the calculation of an equilibrium sailing condition is quite complicated. Today, the main methods used are Velocity Prediction Programs (V.P.P.)²,

¹In the third equation, GZ is the distance between the baricentre and the application point of the buoyancy force B , while h is the distance between the application points of the heeling force and the side force.

²V.P.P. : It is a semiempirical method, based on the resolution of the equation for the static equilibrium between the hydrodynamic and aerodynamic forces, which permits to evaluate the yacht performances under varying wind conditions. The V.P.P. considers the aerodynamic and hydrodynamic forces as function of the yacht speed, the heel angle and the leeway angle. Therefore, to solve these non linear equations, the program

[10], [11], [13]. Recently, Computational Fluid Dynamics (C.F.D.)³ has been increasingly applied, because it permits the calculation of the speed of the yacht in viscous fluid. There are, also, a lot of other methods, but none of these alone can be considered sufficient, but they are complementary. The applications of C.F.D. techniques could reduce some of the problems about model scale.

The dynamic equilibrium is more complex to achieve and there are several aspects to consider.

The first aspect is about the sail. In fact, the forces or the pressure distribution of the wind changes constantly and is affected by the shape of the sail, while the shape of the sail, through cloth stretch and flexing, is affected by the pressure distribution, or force on the sail; at the same time the pressure distribution on the sail stretches and flexes the sail material determining its shape.

The second aspect is about the dynamic motion that the yacht could assume. In fact, when a yacht is sailing to windward, it is easy to believe that the boat is affected by a pitch motion and a rolling motion, particularly when the spinnaker is loaded. As shown in figure 2, these motions are cyclic between their two maximum points. They influence the velocity and the direction of the wind that the crew experience. For all those reasons, those rhythmic motions originate time-varying aerodynamic and hydrodynamic forces.

To complicate matters further, a sail, being soft, will take up a curvature dependent on the

requires information about the stability properties (the designers can give these) and the value of the coefficient of aerodynamic and hydrodynamic forces at various external conditions of the sea and wind (that is the most complex part). Obviously, the calculations are iterative: they start with a value and direction of the wind and the required yacht speed and then calculate the stable configuration (heel and leeway angle) until the solution converges. The hydrodynamic forces carry over from the towing tank results, numerical prediction or semiempirical relation. It is difficult to achieve a good evaluation about the aerodynamic forces. It needs experimental data on the full scale sail because on the small scale model the stretch and other properties of the sail material change. The sail works at maximum lift coefficient and in condition of separated flow and the interaction between the various sails depend on many variables, so it is difficult to predict the sail forces on the small scale model. But full scale sails require considerable time and money to build them and the experiments involve two boats and many people and time to organise it. Lastly, the experiment depends on the weather.

Towing-Tank Testing: It consists in towing a model of the structures of the yacht and it permits to evaluate the hydro- and aerodynamic forces thanks to a dynamometer. Today, two are the principal techniques used, the main difference is about the degree of freedom of the model and the procedure. An issue that has been discussed extensively is the required size of the model and the turbulence stimulation required. The studies show that the error is bigger for the small scale model (10%-20%), while it is reduced for large scale model. They also show that if the turbulence stimulation is right, the error could be reduced for the smaller model. Today the information about the sea condition are empirical as The San Diego Wave Spectrum, because the numerical evaluation was failed.

The usual approach for sail force modeling is to develop a set of semiempirical coefficients, that can be corrected by the measure of the dynamometer on the real boat, by video cameras, photographing the shape of the sails during the sailing.

³ *C.F.D.*: There are a lot of computational programs to evaluate the hydrodynamic and aerodynamic forces, but their main problem is their measures in non-viscous flow. In fact, lately there are studies about the introduction of the viscosity and they have problems about the lead-time and the generation of the grid.

pressure distribution, as mentioned previously. This means that to achieve a condition of dynamic equilibrium is more difficult, and no attempt has been made to measure or calculate the sail force involved. In addition, the dynamic motions produce, simultaneously, time varying hydrodynamic forces, which lead to added resistance in waves. It is, therefore, very important to understand how damping can help this situation, and how the aerodynamic and the hydrodynamic force can contribute with each other.

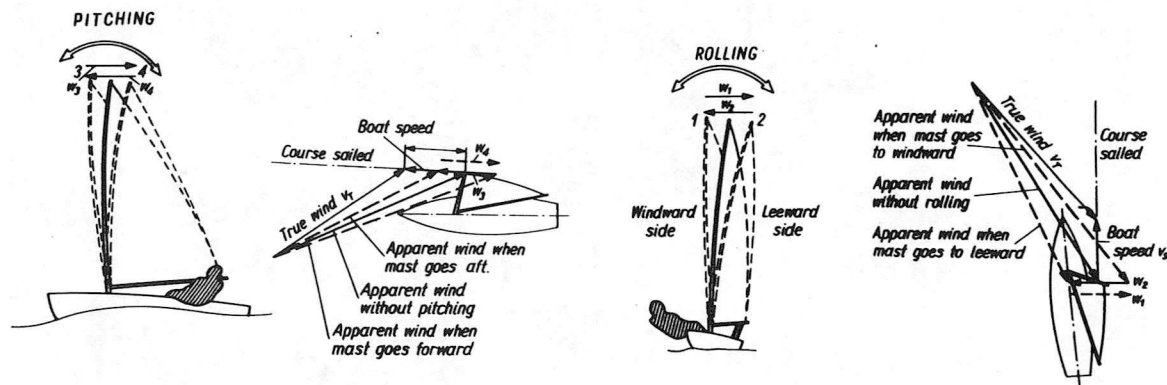

Figure 2: Dynamic motions

There are new methods, like computer vision, that permits visualisation of the dynamic motion of f.e.m. model of structures, checking some performance measurements for the sail.

All the new methods have the same targets, which are the main problems of Sail Design:

- to know, for a given sail plan, the proper sail shapes for each external condition of the sea and of the wind, to produce the best performances
- "how" to reproduce these chosen shapes, quickly.

Every sail-maker factory has developed their own system, but all of these methods use the same technology: they place video cameras at key locations on the boat to document sail shape while underway. They are able to correlate and record changes in sail shapes to be reproduced. During the reproduction they are able to compare the fastest shape for each wind and sea condition. The ability to look at sail after sail with the camera is also used to evaluate and mostly to improve the panel layout and the sail construction techniques. Of course, all of these methods are more expensive because of the technologies, the operators and the maintenance involved, but they are the most time efficient methods to improve sail and boat performances. So, the immediate future in this field is to continue with the camera technologies and to develop advanced software to use all the information and to obtain the best solution to the sail design problem in the real time during races.

3.The Structural Analysis

The simple sail configuration considered for the analysis is shown in the figure 3, where the

three fundamental elements are clearly distinguished: the sail, the mast and the rigs. Because the material and the operation of these elements are completely different from each other, a different structural analysis is required for each one. The first step is to analyse each structure separately and then combine them to obtain the solution for the integrated system.

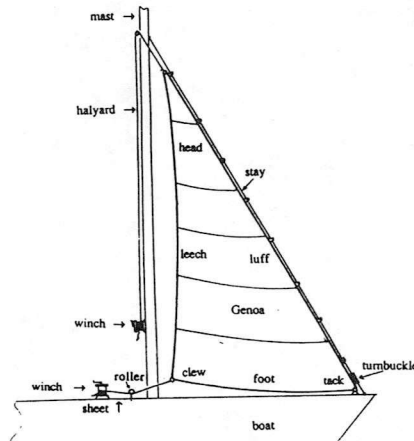

Figure 3: The jib with its rig

The typical shape of the jib and its rig, during the race, is characterised by large displacements from its initial configuration without wind. The sail is full and the rig is in tension because the mast is bending, and the wires are in tension to keep the sail shape.

3.1. Non-linear structural analysis

This last consideration and the discussion about the aeroelastic behaviour of the sail configuration, mentioned above, have the following implications:

- the displacements are large,
- the material behaviour may not be always linear elastic,
- the nature of the boundary conditions changes during the application of the loads,
- the displacements will not be a linear function of the applied load vector

To achieve a numerical structural analysis, the Finite Element Method should be used, building the most representative model possible. This means that it is necessary to choose the finite element for each of the structures, and the structural relations closest to reality.

The model is based on the need to treat a sail like an easily-deformed membrane structure, the mast like a deformable beam and the wire like a cable structure.

When the finite element model is obtained, the resulting numerical structural analysis will be non-linear, for the above reasons.

The basic problem in a general non linear analysis is to find the state of equilibrium of a body corresponding to the applied loads, [14].

The equilibrium condition of a system of finite elements, representing the body under applied load, can be expressed as:

$${}^tR + {}^tF = 0 \quad (1)$$

where the vector tR lists the externally applied nodal point forces in the configuration at the same time t , and the vector tF lists the nodal point forces, that corresponds to the element stresses in the equilibrium configuration. The equation (1) must express the equilibrium of the system in the current deformed geometry taking due account of all nonlinearities, and also must be satisfied throughout the complete history of a load application. As the constitutive relations are non-linear, the equilibrium equation cannot be solved directly. An approximate solution can be obtained by referring all variables to a previously calculated known equilibrium configuration and linearizing the resulting equations. This solution can be improved by iteration.

To solve the problem, in practice, the choice lies essentially between two formulations which have been termed Total Lagrangian formulation (T.L.)⁴ and Update Lagrangian formulation (U.L.)⁵. Both T.L. and U.L. formulations include all kinematics and non linear effects. Because the difference is only about the reference configuration, the numerical solution will give the same result. The choice between them depends on the finite element model and the constitutive laws used.

In the present formulation, the Total Lagrangian Formulation will be used, because it is assumed that the shape of the sail is known at the time $t=0$, corresponding to an unloaded configuration.

This discussion is relative to a general non-linear analysis for a continuum, but that forms the bases of general non-linear displacement finite element analysis. These equations, are used to develop the governing finite element equations.

The basic steps in the derivation of the governing finite element equations are:

- the selection of the interpolation functions between the internal point of each element and the nodal point and employing the same interpolations functions for the element co-ordinates;
- obtain the governing finite element equations for each element invoking the principle of virtual work⁶;

⁴In the Total Lagrangian formulation, all static and kinematics variables are referred to the initial configuration at the time $t=0$

⁵In the Update Lagrangian formulation, the same variables are referred to the configuration at the time t .

⁶The Principle of the virtual work relates to two distinct and separate systems in which the first is a set of forces in equilibrium (P and σ as the external forces and internal stresses, respectively), and the seconds a set of geometrically compatible deformations (U and ϵ as the displacements and strains, respectively).

The principle of virtual work states that for any system in equilibrium, the external virtual work must be equal to the internal virtual. In practice, one of the system always relates to a real or actual structure, in which some sort of solution is required, while the others is an imaginary or virtual system. Therefore, it is possible to have the option of establishing:

⇒ Theorem of virtual forces in which a real system of displacement and strain is coupled to a virtual system of forces and stresses

- linearize the obtained non-linear equations for each element;
- assemble the equations and solve, with the Newton-Raphson iterative solution method.

About the first step, there will be more details in the next paragraph, because it depends of the finite element used.

The problem, obtained from the P.V.W. formulation, [12], could be written as follow:

$$\exists U: F_{\text{int}}(U) = F_{\text{ext}} \quad (2)$$

or, in words, find the displacement node vector U , corresponding to an equilibrium and compatible system configuration, such that the calculated internal forces at each node, which balance the internal stresses, are equal to the external forces (or applied forces).

The non-linear system of equations (2) is solved by the standard Newton-Raphson method. The iterate (U^i) is constructed by:

$$U^0 = 0;$$

$$\forall i \geq 1, \left[\frac{dF_{\text{int}}}{dU}(U^{i-1}) \right] \cdot \{U^i - U^{i-1}\} = -\{F_{\text{int}}(U^{i-1}) - F_{\text{ext}}\};$$

where $\frac{dF_{\text{int}}}{dU}(U^{i-1})$ is the stiffness operator of the finite element system when the displacement of the free nodes is U^{i-1} .

The stiffness matrix for each finite element is derived below. First, it is important to consider the main difficulty in implementing software to compute the vectors:

$$F_{\text{int}}(U), \quad F_{\text{ext}}(U), \quad \frac{dF_{\text{int}}}{dU}(U)$$

particularly for the first iteration, because the stiffness matrix is singular if it is evaluated for the displacement vector $U^0 = 0$. For this reason the following structural analysis adopts a strategy of performing an initial linear analysis, to find an equilibrium and compatible configuration for the system, after which a non-linear solution is obtained using the displacement vector from the previous linear solution, U^0 . In this way, for the first iteration the stiffness matrix will be not singular, because the vector $U^0 \neq 0$.

Another problem concerns the velocity of the convergence of the iteration method adopted, because large displacement components are obtained from the first iteration, due to the ill conditioned stiffness matrix. To improve convergence the procedure outlined below is employed.

\Rightarrow Theorem of virtual displacements in which a real system of forces and stresses is coupled to a virtual system of displacements and strains.

The last one is used to derive the stiffness matrix in the non linear analysis and its formulation is

$$\sum P \cdot \delta U = \int_V \sigma \cdot \delta \epsilon dV$$

For any small scalar ΔU_{\max} positive, the Newton-Raphson procedure will be modified in the following way:

$$U^0 = U^i;$$

$$\forall i \geq 1$$

$$\Delta U^i: \left[\frac{dF_{\text{int}}}{dU}(U^{i-1}) \right] \cdot \{\Delta U^i\} = -\{F_{\text{int}}(U^{i-1}) - F_{\text{ext}}\};$$

$$U^i = U^{i-1} + \min\left(\frac{\Delta U_{\max}}{\|\Delta U^i\|}, 1\right) \cdot \Delta U^i$$

In this way the difference between two consecutive evaluated displacement components cannot be greater than the limited ΔU_{\max} . Convergence will be got when

$$\frac{\|F_{\text{int}}(U^i) - F_{\text{ext}}\|}{\|F_{\text{ext}}\|} \text{ and } \frac{\|U^i - U^{i-1}\|}{\|U_{\max}^{i-1}\|}$$

are smaller than a predetermined value. The final configuration for the system is dependent on the displacement vector U^i .

3.2. The Sail

To achieve the finite element model for the sail it seems very important to consider several problems involved in the definition of the shape and, also, of the structural properties of the sail. These problems are considered below, which the finite element formulation for a sail is given.

3.2.1. Geometry

The nomenclature for a full-scale sail is given in figure 4, [8], with the sail shape defined by sections at different heights and characterised by chord length, twist from the centreline and camber as a function of distance from the luff.

The important factors are :

- a) *the vertical depth⁷ distribution*: a good sail does not possess uniform depth from top to bottom: the depth will be greater at the head and flatter at the foot.
- b) *the max. depth and its location in a sail section*: there is no one ideal depth and no one ideal position of max. depth in all conditions, but for any given :
 - wind velocity
 - wind direction
 - sea condition
 - boat velocity

⁷The depth (or draft) is the sail curvature and usually it is defined as a percentual rate between the value of the max. curvature and the chord (straight line between the leech and the luff)

their required values are different for providing optimum performance, [18]. In light air and when the sea is flat, good depth is around 18%-19%, while the position of the max. depth is around 48% of the chord. As the wind increases, the designed depth may be as far forward as 38%-40%, while the section may be flatter. Fuller sails, or sails with large curvature, generate more power. Although this helps the boat to accelerate, it also makes the boat livelier and more difficult to be stopped by waves. So, a fuller sail works better in light air and a flatter sail works better from medium to heavy air. The required versatility for every sailing condition is achieved by adjustments and trimming⁸.

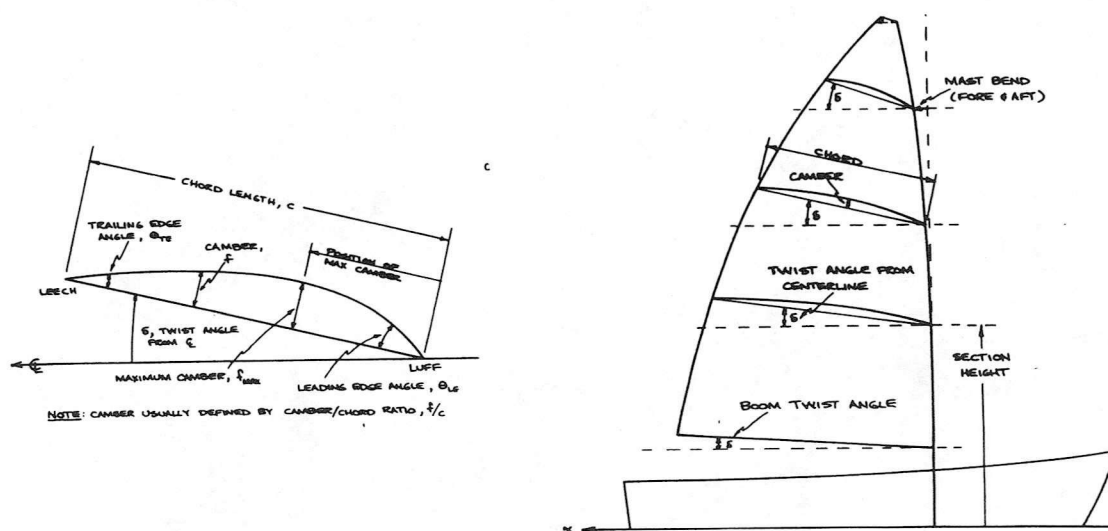

Figure 4: Geometric nomenclature for a sailing yacht

However, to get all this geometric information is very difficult. Several methods have evolved for measuring a sail's shape, [1]. These procedures find the draft and the draft position ratios at several elevations. Two of them find the shape while the sails are hoisted. They have the advantage of measuring the sail shape while the sail fabric is loaded and, hence, stretched by the wind. In a direct measurement procedure, the actual chords, depth and depth position are measured while the yacht is positioned in a slip. The shape parameters are measured with the aid of tape measures, rules etc. But, this procedure has the problem that when the yacht is in a slip, it is difficult to insure that the sails are trimmed for the maximum efficiency.

In response to these problems, a photographic technique has come into popular use. Here, the sail is marked with horizontal draft stripes at one quarter or one third of the elevation. Then, while the yacht is sailing at maximum efficiency, the draft stripes are photographed

⁸ See the paragraph 3.2.5.Trim

from the deck or from aloft. Later, the photographs are analysed by computer program to determine the shape parameters.

Today, the latter method is the most widely used, because the obtained measurements are relative to the real sail shape, and the errors negligible. However, at same time, it is possible to obtain only discrete information about the geometric parameters of the tridimensional sail surface. Hence, the first problem in the geometric definition is to get the surface using only limited information from a few section. Usually, the main information available are :

- max. depth;
- position of max. depth;
- twist referred to the boat centreline
- entry angle referred to the local chord;
- exit angle referred to the local chord;

at three or sometimes more sections, and also rig measurements:

- luff and foot length.

This means that it is necessary to find a method that can build a 3-dimensional surface using the above information. Actually, the sections are drawn using Bezier curves, [6]. In the present work, a new method is used, [4], that builds a surface using one extension of the technique of Bezier curves. The authors of this method have demonstrated that the surface obtained will be free of any local flatness and bulge and they define this surface as "smooth".

Their proposed construction method consists of:

- 1) construction of chord length spline mesh curves from the input data;
- 2) conversion of each cubic curve segment to a sextic Bezier curve;
- 3) determination of "off-boundary" control points and
- 4) determination of "internal" control points.

Concerning the first step, because the tangents at the first and the last point of a sail section are known (they correspond to the entry and exit angle), a smooth curve is built by fitting the tangents of a sequence of estimated internal points. These points are calculated applying the continuity conditions. This cubic Bezier curve is then elevated to 6. Subsequently, the "off boundary control" points are determined by imposing the condition that the tangent planes of the two patches along the common boundary curve coincide.

Using this method, it is possible to build a geometric model of the sail when only limited data are available. In fact the developed code uses only the following information:

- a) the co-ordinates of the origin of the local co-ordinate system⁹ (x_0, y_0, z_0) ;
- b) chord length;
- c) the co-ordinates of the max. depth (position and value of the max. depth (x_{\max}, y_{\max}));

⁹The local co-ordinates system has the origin of the first point of the leading edge of each section and with the x-axis along the chord of the section and the y-axis in the plane of the section

- d) entry angle α_{entry} (tangent angle to the leading edge in the local co-ordinate system);
- e) exit angle α_{exit} (tangent angle to the trailing edge in the local co-ordinate system);
- f) twist angle (angle between the x-axis of the local co-ordinate system and the X-axis of the global co-ordinate system).

This information is written in a data file, and read by the code, which builds the Bezier cubic curve in the two directions: along the section and along the mast. After that it builds the patches between two consecutive sections and the surface. The same code saves the co-ordinates of the points corresponding to the nodes in the finite element model.

3.2.2. Properties

From the importance of the depth distribution and magnitude, and, also the importance of maintaining the chosen configuration for the sail plane, the most desired sail properties are the following, [18], [19], [20]:

- *structural properties:*
 - a) low stretching: a sail's cloth can have different values of stretch in the different directions. The stretch can also be dependent on time: some materials, when initially loaded, will have a little stretch, but if the load is maintained over a long period of time, they will gradually elongate. When the load is removed, some of the materials will recover or return to their original dimensions. This tendency in sailcloth is known as *recovery*. Some cloth will never recover its initial dimensions. This non recoverable strength is known as *creep*. Stretch is caused by many things. some are geometrical, some are simply due to the elongation of the fibres. Stretch characteristics are very important in determining the optimum load for a cloth. Because the sail's cloths experience large displacements during a race, a low value of stretching is recommended .
 - b) high strength: it is very important to know the value of the breaking strength and the yield strength (when the material is not recoverable). It is also obvious to use a material with a high value of the yield point, and with linear constitutive stress-stretch relation, because , in this way, the constitutive relations for the material will remain linear, in its operating environment;
 - c) light weight: because low weight means higher velocity for the yacht and at the same time, low pitch and roll moment in light air (greater boat stability);
 - d) porosity, damage resistance, sunlight resistance: these properties lengthen the life of a sail.
- *max. wind range*: the lowest is the minimum wind required to fill a sail to its optimum shape, the highest is the max. value of the wind at which the sail holds its designed shape;
- *durability*;
- *handling*: the time to trim the sails must be low;
- *agility*: possibility to accelerate in a short time.

At this point, it is clear that to get a sail with high value of performance, the choice of material an the construction method is important .

3.2.3. Material

The last few years have seen a virtual explosion in the development of new sail fabric, largely as a result of the evolution of suitable synthetic films, [15], [19], [20].

Four basic cloth fibres are used in modern sail making: Nylon, Dracon, Kevlar and Spectra. All of these can be used alone, but often two or more are used in a composite construction that takes advantage of the virtues of each. These fibres work by increasing the strength of a sail's cloth along particular directions depending on the fabric. In fact, a woven cloth (figure 5.a) has threads running in two directions: *fill* threads run across the width and *warp* threads run along the length of the cloth, while the *bias* is any direction off the warp or fill. This means that, for example, a warp-oriented cloth is stronger in the long direction than in the fill.

Dracon, used for mains and jib, and *Nylons*, used for spinnakers, belong to the same cloth group. They are relatively inexpensive but degrade in sunlight and tend to stretch. Nowadays, they are used after particular processing e.g., resination and heat-treatments). These processes improve their stability and durability and reduce their non-recovery tendency .

Kevlar could be considered strong and resistant to stretch for its light weight. Sails made from Kevlar fibres have unbeaten shape holding ability over a wide range of wind conditions. They are also good handling properties due to their light weight. However, they are also susceptible to ultraviolet degradation, and break quickly when flogged or abraded. Kevlar can be used only in one direction: warp or fill, and this means maximum strength only in one direction. Hence, for these reasons, they are combined with Dracon or other fibres and more layers of Kevlar in different directions to obtain more multidirectional strength. This improvement of the characteristics means more weight and poorer sail handling.

Spectra fibre is a polyethylene variation, and it has high strength-to-weight ratio, but it is also expensive. Spectra has one important advantage over Kevlar, i.e. the flexibility, and also it is resistant to sunlight. For these reasons, it is recommended for large sails.

Laminates consist of a densely woven polyester substrate but also of additional layers of Mylar and Kevlar yarns of various weights and thicknesses. By laminating one or more layers of woven cloth or Mylar/Kevlar film, the cloth becomes more stable in directions other than warp or fill, and at the same time, gives better performance.

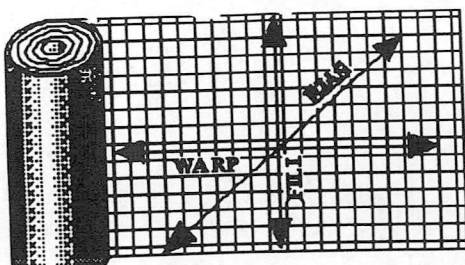

Figure 5.a: woven cloth

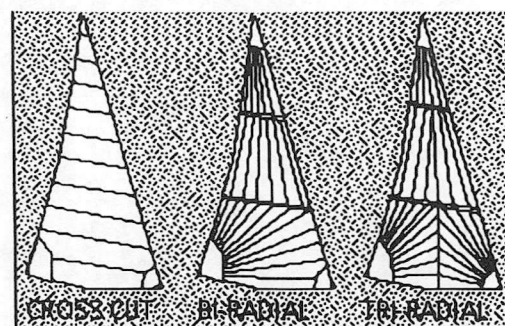

Figure 5.b: Construction method

3.2.4. Construction Method

To achieve more strength where the stress is high and, at the same time, a low weight, almost every sail maker tries to design sails on a computer, [20]. The greatest effort goes into building a sail that will keep its intended shape. The main construction methods (figure 5.b) are the following:

- 1) *crosscut* : the layout has all panels parallel to each other and perpendicular to the leech. Each panel has the greatest strength in the fill direction. This is the traditional layout for main and jib sails.
- 2) *bi-radial* : the layout consists of a set of radial panels emanating from the head and from the clew. A horizontal seam joins the two sections. Warp oriented fabrics are used.
- 3) *tri-radial* : the layout is like the bi-radial one, but this layout has radial panels from the three corners, and so there is a vertical seam also to join the three sections.

Each sail maker has their own construction method, based on a combination between the three methods above.

3.2.5. Trim

As mentioned previously, during a race it is possible to have different external conditions, and for each one there is a best configuration. This configuration can be obtained by adjustments and trimming. To make adjustments involves changing the amount and location of the depth, while to trim involves controlling the shape of the leech and its incidence angle.

Detailed below, for each sail is the principal method to achieve and maintain a configuration a [20].

The mainsail is used to increase the lift of the sail plan by increasing both the surface of the foil that the wind sees and the amount of curvature. So, the basic controls of the mainsail are:

- *luff tension*: if increased will reduce the draft ;
- *foot tension*: if increased will reduce the draft ;
- *leech tension*: if increased will straighten the shape will and decrease the twist ;
- *mast bend*: reduces the draft will decrease and flattens the sail.

The jib is positioned upstream of the mainsail, and therefore is the first sail that the wind see. The basic controls are the amount and location of the draft and the angle of entry, affected by:

- *luff tension*: if increased, will move the draft forward;
- *jib lead*: controlled by the tension on the leech and the foot, as well as the draft location in the upper and lower portion of the sail. If the jib is loaded aft, the draft will be forward at the top of the sail and aft at the bottom.
- *sheet tension*: controls the amount of the draft and the twist. A tight jib sheet will remove the draft from the sail.

- *headstay tension*: if increased, reduces the draft and flattens the entry angle.

The spinnaker is a versatile sail which can be used when the wind is blowing anywhere from 60 to 180 degrees. The optimal angle depends on the wind strength, the unique limits are governed by the maximum pole position and sheet position.

3.2.6. Finite element formulation for the sails: Membrane element

The sail cloth is very thin (about 0.5 mm) in respect to sail size, and is also flexible. Both properties had to the choice of membrane elements to discretize the sail. This means that variation of the mechanical quantities such as the displacement field, stresses and strains is neglected through the thickness. Hence the sail has in-plane but not flexural stiffness, and can only resist transverse loads by virtue of its curvature.

For the finite element analysis, [17], a typical triangular element is considered (figure 6).

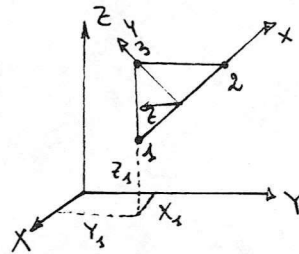

Figure 6: triangular element

If (X,Y,Z) is a global reference frame and (x,y,z) is an element Cartesian co-ordinate system,

$$\begin{Bmatrix} u(x,y) \\ v(x,y) \\ w(x,y) \end{Bmatrix}$$

is the displacement vector of a point $P(x,y)$ belonging to this element in the element Cartesian co-ordinate system.

The linear variation of these components, are

$$\begin{cases} u(x,y) = \alpha_1 + \alpha_2 x + \alpha_3 y \\ v(x,y) = \alpha_4 + \alpha_5 x + \alpha_6 y \\ w(x,y) = \alpha_7 + \alpha_8 x + \alpha_9 y \end{cases} \quad \text{where } \alpha_i \quad \forall i = 1 \dots 9 \text{ are unspecified coefficients.}$$

It is useful to express the α_i coefficients in term of the 9 nodal displacement components:

$$U = [u_1, v_1, w_1, u_2, v_2, w_2, u_3, v_3]^T,$$

evaluating the displacements at the three nodes:

$$\text{node 1: } \begin{cases} u_1 = u(x_1, y_1) = \alpha_1 + \alpha_2 x_1 + \alpha_3 y_1 \\ v_1 = v(x_1, y_1) = \alpha_4 + \alpha_5 x_1 + \alpha_6 y_1 \\ w_1 = w(x_1, y_1) = \alpha_7 + \alpha_8 x_1 + \alpha_9 y_1 \end{cases}$$

$$\text{node 2: } \begin{cases} u_2 = u(x_2, y_2) = \alpha_1 + \alpha_2 x_2 + \alpha_3 y_2 \\ v_2 = v(x_2, y_2) = \alpha_4 + \alpha_5 x_2 + \alpha_6 y_2 \\ w_2 = w(x_2, y_2) = \alpha_7 + \alpha_8 x_2 + \alpha_9 y_2 \end{cases}$$

$$\text{node 3: } \begin{cases} u_3 = u(x_3, y_3) = \alpha_1 + \alpha_2 x_3 + \alpha_3 y_3 \\ v_3 = v(x_3, y_3) = \alpha_4 + \alpha_5 x_3 + \alpha_6 y_3 \\ w_3 = w(x_3, y_3) = \alpha_7 + \alpha_8 x_3 + \alpha_9 y_3 \end{cases}$$

This is a system of 9 equations in 9 unknown coefficients α_i . Because the values of the nodal co-ordinates (x_1, y_1) , (x_2, y_2) , (x_3, y_3) , are known, it is possible to solve for α_i

$$\begin{cases} u(x, y) = (a_1 + b_1 x + c_1 y)u_1 + (a_2 + b_2 x + c_2 y)u_2 + (a_3 + b_3 x + c_3 y)u_3 \\ v(x, y) = (a_1 + b_1 x + c_1 y)v_1 + (a_2 + b_2 x + c_2 y)v_2 + (a_3 + b_3 x + c_3 y)v_3 \\ w(x, y) = (a_1 + b_1 x + c_1 y)w_1 + (a_2 + b_2 x + c_2 y)w_2 + (a_3 + b_3 x + c_3 y)w_3 \end{cases} \quad (3)$$

where:

$$\begin{aligned} a_1 &= (x_2 y_3 - x_3 y_2) / 2\Delta & b_1 &= (y_2 - y_3) / 2\Delta & c_1 &= (x_2 - x_3) / 2\Delta \\ a_2 &= (x_3 y_1 - x_1 y_3) / 2\Delta & b_2 &= (y_3 - y_1) / 2\Delta & c_2 &= (x_3 - x_1) / 2\Delta \\ a_3 &= (x_1 y_2 - x_2 y_1) / 2\Delta & b_3 &= (y_1 - y_2) / 2\Delta & c_3 &= (x_1 - x_2) / 2\Delta \end{aligned}$$

with

$$2\Delta = \det \begin{vmatrix} 1 & x_1 & y_1 \\ 1 & x_2 & y_2 \\ 1 & x_3 & y_3 \end{vmatrix} = 2(\text{area of triangle})$$

Then, if the element nodal co-ordinates and their displacements in the element co-ordinate system are known, the displacement components of a generic point P(x,y) internal to this element will be known. For this reason, the equations (3) are called "*ELEMENT SHAPE FUNCTIONS*".

The membrane element is incapable of sustaining flexural stresses. The stress components, at each point, are tangent to the curved surface of the membrane to equilibrate normal loads. As the loads change, the stresses and the local curvature change to maintain equilibrium and those changes are accompanied by significant displacements and rotations of the surface. Because the displacements and rotations of the fibres are large, the small deflection theory of

linear elasticity is inapplicable.

The non-linear displacement-strain relations are, for a typical element in the element coordinate system:

$$\left\{ \begin{array}{l} \varepsilon_x = \frac{\partial u}{\partial x} + \frac{1}{2} \left[\left(\frac{\partial u}{\partial x} \right)^2 + \left(\frac{\partial v}{\partial x} \right)^2 + \left(\frac{\partial w}{\partial x} \right)^2 \right] \\ \varepsilon_y = \frac{\partial v}{\partial y} + \frac{1}{2} \left[\left(\frac{\partial u}{\partial y} \right)^2 + \left(\frac{\partial v}{\partial y} \right)^2 + \left(\frac{\partial w}{\partial y} \right)^2 \right] \\ \gamma_{xy} = \frac{\partial u}{\partial y} + \frac{\partial v}{\partial x} + \frac{1}{2} \left[\left(\frac{\partial u}{\partial x} \frac{\partial u}{\partial y} \right) + \left(\frac{\partial v}{\partial x} \frac{\partial v}{\partial y} \right) + \left(\frac{\partial w}{\partial x} \frac{\partial w}{\partial y} \right) \right] \end{array} \right.$$

where the derivatives of element shape functions, will be obtained from the original function. For example, for the first strain component, the first derivative will be:

$$\frac{\partial u}{\partial x} = b_1 u_1 + b_2 u_2 + b_3 u_3 \quad \text{and so on.}$$

Then, the complete expression for the same strain component will be:

$$\varepsilon_x = b_1 u_1 + b_2 u_2 + b_3 u_3 + \frac{1}{2} \left[(b_1 u_1 + b_2 u_2 + b_3 u_3)^2 + (b_1 v_1 + b_2 v_2 + b_3 v_3)^2 + (b_1 w_1 + b_2 w_2 + b_3 w_3)^2 \right]$$

and so on for the other components. In matrix form:

$$\left\{ \begin{array}{l} \varepsilon_x \\ \varepsilon_y \\ \gamma_{xy} \end{array} \right\} = \left[\begin{array}{ccccccccc} b_1 & 0 & 0 & b_2 & 0 & 0 & b_3 & 0 & 0 \\ 0 & c_1 & 0 & 0 & c_2 & 0 & 0 & c_3 & 0 \\ c_1 & b_1 & 0 & c_2 & b_2 & 0 & c_3 & b_3 & 0 \end{array} \right] \left\{ \begin{array}{l} u_1 \\ v_1 \\ w_1 \\ u_2 \\ v_2 \\ w_2 \\ u_3 \\ v_3 \\ w_3 \end{array} \right\} + \frac{1}{2} \left[\begin{array}{cccccc} \frac{\partial u}{\partial x} & \frac{\partial v}{\partial x} & \frac{\partial w}{\partial x} & 0 & 0 & 0 \\ 0 & 0 & 0 & \frac{\partial u}{\partial y} & \frac{\partial v}{\partial y} & \frac{\partial w}{\partial y} \\ \frac{\partial u}{\partial y} & \frac{\partial v}{\partial y} & \frac{\partial w}{\partial y} & \frac{\partial u}{\partial x} & \frac{\partial v}{\partial x} & \frac{\partial w}{\partial x} \end{array} \right] \left\{ \begin{array}{l} \frac{\partial u}{\partial x} \\ \frac{\partial v}{\partial x} \\ \frac{\partial w}{\partial x} \\ \frac{\partial u}{\partial y} \\ \frac{\partial v}{\partial y} \\ \frac{\partial w}{\partial y} \\ \frac{\partial u}{\partial x} \\ \frac{\partial v}{\partial x} \\ \frac{\partial w}{\partial x} \end{array} \right\}$$

in symbolic form, it is possible to write:

$$\varepsilon = Bu + \frac{1}{2} A \vartheta$$

where:

$$A = \begin{bmatrix} \frac{\partial u}{\partial x} & \frac{\partial v}{\partial x} & \frac{\partial w}{\partial x} & 0 & 0 & 0 \\ 0 & 0 & 0 & \frac{\partial u}{\partial y} & \frac{\partial v}{\partial y} & \frac{\partial w}{\partial y} \\ \frac{\partial u}{\partial y} & \frac{\partial v}{\partial y} & \frac{\partial w}{\partial y} & \frac{\partial u}{\partial x} & \frac{\partial v}{\partial x} & \frac{\partial w}{\partial x} \end{bmatrix}$$

$$\vartheta = \begin{bmatrix} \frac{\partial u}{\partial x} \\ \frac{\partial v}{\partial x} \\ \frac{\partial w}{\partial x} \\ \frac{\partial u}{\partial y} \\ \frac{\partial v}{\partial y} \\ \frac{\partial w}{\partial y} \end{bmatrix} = \begin{bmatrix} b_1 & 0 & 0 & b_2 & 0 & 0 & b_3 & 0 & 0 \\ 0 & b_1 & 0 & 0 & b_2 & 0 & 0 & b_3 & 0 \\ 0 & 0 & b_1 & 0 & 0 & b_2 & 0 & 0 & b_3 \\ c_1 & 0 & 0 & c_2 & 0 & 0 & c_3 & 0 & 0 \\ 0 & c_1 & 0 & 0 & c_2 & 0 & 0 & c_3 & 0 \\ 0 & 0 & c_1 & 0 & 0 & c_2 & 0 & 0 & c_3 \end{bmatrix} \begin{bmatrix} u_1 \\ v_1 \\ w_1 \\ u_2 \\ v_2 \\ w_2 \\ u_3 \\ v_3 \\ w_3 \end{bmatrix} \quad \text{or in symbolic form } \vartheta = Gu$$

Substituting in the symbolic expressions for the strain, the result is

$$\varepsilon = \left(B + \frac{1}{2} AG \right) u$$

To describe the constitutive relations for the same sailcloth, it is important to remember that one of the sail maker's targets is to build a sail with the lowest value of stretch possible. Modern fibres such as Kevlar and Mylar, are quasi-inextensible, or in other words, variation of the length fibre and of the angle between fibres are small. This means that the strain is small. However, the stress-strain relations could be linear or non linear. Recalling the discussion about fibre orientation and the general layout of a sail, the sailcloth could be described as an orthotropic material, but to simplify the problem, initially the seam effect is neglected and the sail's material is considered homogeneous and isotropic. This simplification maintains the linear relation between strain and stress, but only one value for the elastic modulus is required.

Given the above assumptions, it is possible to use the "CONSTITUTIVE RELATIONS FOR LINEAR ELASTIC PLANE STRESS":

$$\sigma = D\varepsilon + \sigma_0$$

where: σ_0 is the initial stress vector;

D is the elastic matrix defined as:

$$D = \frac{E}{1-\nu^2} \begin{bmatrix} 1 & \nu & 0 \\ \nu & 1 & 0 \\ 0 & 0 & \frac{1-\nu^2}{2} \end{bmatrix} \text{ and } E \text{ is the Young's modulus and } \nu \text{ the Poisson's ratio.}$$

The next step is to find the equilibrium equations for the system. Recalling that the Lagrangian approach of the finite displacement theory is used, the co-ordinates defining a point on the body before deformation are referred to.

Mentioned earlier the equations, for a single element in the local co-ordinate system may be obtained via '*principle of the virtual work*'. Assuming that an infinitesimal virtual displacement δu is executed from an equilibrium configuration of the sail, a virtual strain $\delta \epsilon$ results from the displacement, the equation (2) for such element becomes:

$$\int_{V_e} \delta \epsilon^T \sigma dV = \int_{V_e} \delta u^T F_v dV + \int_{S_e} \delta u^T F_s dS$$

where V_e is the element volume and S_e the element surface. The term on the left-side represents the virtual work due to the internal force. The term on the right-side represents the virtual work due to the external loads: F_v is the body force vector, while F_s is the nodal force vector acting on the element surface. Considering both the external nodal force vectors known it is possible to re-write the principle as follow:

$$\int_{V_e} \delta \epsilon^T \sigma dV - \delta u^T p = 0 \quad (4)$$

Using the last symbolic expression, the strain increment is

$$\delta \epsilon = [B + AG] \delta u$$

and substituting this expression into equation (4), the result is:

$$\int_{V_e} [(B + AG) \delta u]^T \sigma dV - \delta u^T p = 0$$

and if the expression for stress is substituted:

$$\int_{V_e} [(B + AG) \delta u]^T \left[D \left(B + \frac{1}{2} AG \right) + \sigma_0 \right] dV - \delta u^T p = 0 \quad (5)$$

This is the equation of element equilibrium.

These equations must be transformed to the global co-ordinate system and finally assembled to obtain the "global equilibrium equations". These equations are non linear, and they will be solved iteratively by the Newton-Raphson method.

To this end, the governing equations for each element must be linearized:

$$\varphi_i = \int_{V_e} (B + A^i G)^T \left[D \left(B u^i + \frac{1}{2} A^i \vartheta^i \right) + \sigma_0 \right] dV - p$$

is the residual term after the i -th iteration The next step is obtained from:

$$\varphi^{(i+1)} = \varphi^i + \frac{\partial \varphi^i}{\partial u} \Delta u^i = 0$$

or

$$\frac{\partial \varphi^i}{\partial u} \Delta u^i = -\varphi^i \quad (6)$$

From this equation the incremental displacements may be computed and the displacements after the $(i+1)$ th iteration can be expressed as

$$u^{i+1} = u^i + \Delta u^i$$

In equation (6), the derivative $\frac{\partial \varphi^i}{\partial u}$ is the element stiffness matrix and it consists of two parts, as it follows:

$$\begin{aligned} K_m^i &= \frac{\partial \varphi_i}{\partial u} = \int_{V_e} (B + A^i G)^T \frac{\partial}{\partial u} \left[D \left(B u^i + \frac{1}{2} A^i \vartheta^i \right) \right] dV + \\ &\int_{V_e} \frac{\partial}{\partial u} \left[(B + A^i G^i)^T \right] \times \left[D (B u^i + A^i \vartheta^i) + \sigma_0 \right] dV = \\ &K_e^i + K_g^i \end{aligned}$$

where K_e^i is the elastic stiffness matrix, defined as follows:

$$K_e^i = \frac{\partial \varphi_i}{\partial u} = \int_{V_e} (B + A^i G)^T \left[D (B + A^i G^i) \right] dV$$

and K_g^i is the geometric stiffness matrix:

$$K_g^i = \int_{V_e} G^T \frac{\partial (A^i)^T}{\partial u} \sigma dV = \int_{V_e} G^T M^i G dV$$

where

$$M^i = \begin{bmatrix} \sigma_x & 0 & 0 & \tau_{xy} & 0 & 0 \\ 0 & \sigma_x & 0 & 0 & \tau_{xy} & 0 \\ 0 & 0 & \sigma_x & 0 & 0 & \tau_{xy} \\ \tau_{xy} & 0 & 0 & \sigma_y & 0 & 0 \\ 0 & \tau_{xy} & 0 & 0 & \sigma_y & 0 \\ 0 & 0 & \tau_{xy} & 0 & 0 & \sigma_y \end{bmatrix}$$

Both element stiffness matrices could be computed only if the displacements u, v, w are known. To start the iterative solution, a compatible but not necessarily equilibrating displacement field is needed. Once the element matrices are assembled in the global equations, new displacement fields will be computed. Using these displacements, new element matrices will be established and the process will be repeated until the computed global displacements agree with the displacements used to compute the element matrices. Then the displacements will be both compatible and equilibrating.

The developed code builds the finite element model, assigning the element nodes to the saved nodal points from the geometrical model. Figure 7 illustrate an example of a finite element model.

3.3. The mast and the rig

The rig of a sailing yacht, [2], illustrated in figure 2, shows for a simple configuration, a structure composed of a mast and boom, which support the sails, and can be considered like beams. Several wires are used to link these sails to the mast, or to give a particular shape to the sails, but when the yacht is sailing the rig experiences large deformations, so the structural analysis is not simple. The mast can be considered as a beam column: in fact it is loaded by axial and transverse forces acting in the longitudinal and transverse planes. The bending and compression loads are balanced by the stay and shroud. Given the complexity of the load, most often empirical criteria are used to design it. But these empirical methods are not accurate if the mast belongs to a racing yacht. On a racing yacht the mast is designed to the criteria of maximum performance increasing the sail efficiency and minimising the weight. This means a thin transverse section avoiding as much as possible parasitic wind resistance and interference with the sail, and with good flexibility to permit a rapid change of shape. For these reasons a correct structural analysis of mast has to be performed using finite element non linear analysis due to the large displacements.

Before the stress analysis, it is important to describe the mast loading. The main loads are due to the forces developed by the sails, the action of the halyards, sheet boom, shrouds and stays. The problem is to know the mechanism by which the pressure field generated by the sails is transmitted to the mast and the rigging. All the methods used consider the total lift developed by the mainsail to be distributed along the mast, while in a number of cases the total

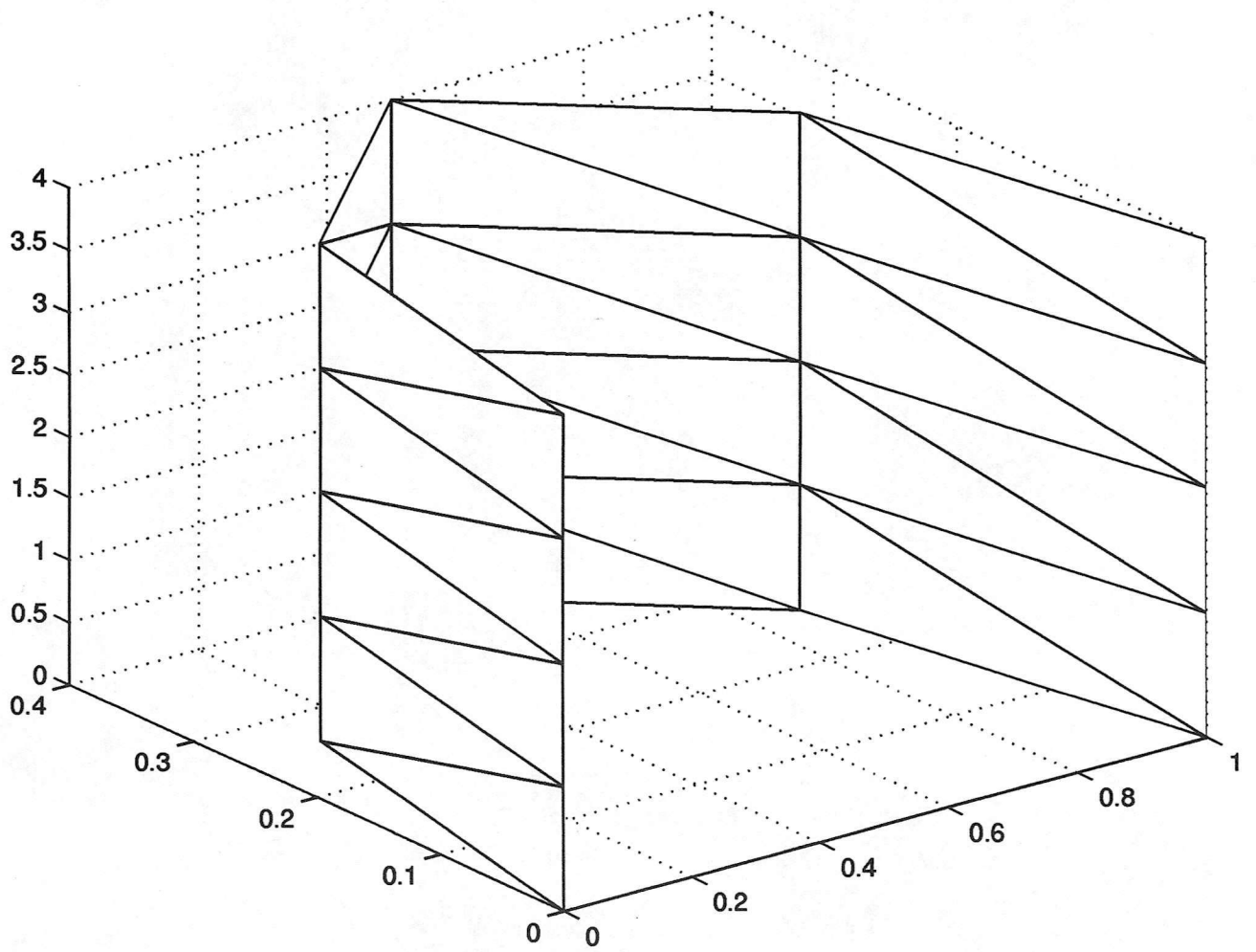

FIGURE 7 : MEMBRANE MODEL

lift developed by the jib is represented by a concentrated load on the mast head. Therefore, it is more correct to say that the mast is not loaded by the pressure distribution but by the sail. In fact, the sail is a membrane, so it transmits the stress of bending and transverse shear to the mast through the connection points. In the present work, only the jib is considered ; The load is assumed to be. This load is split into the bending component and compression component and these forces are transmitted to the attachment point between the jib and the mast. The magnitude of this force depends on the deflection of the luff. It is well known that it is not possible to eliminate completely the deflection of the luff even with very high pressure tension values. It is quite usual to damage the mast if the tension of the leech is too high. It must be remembered that every sail maker builds their own sail and the differences among these are large. This means that for each constitutive solution adopted by the sail maker, the stresses over the sail and, of course, the loads on the rig will be different each time given the same environmental condition and trimming. This means that there will be a mast for each sail, and a different stress distribution, also.

The main purpose of the present work is not to investigate the different mast conditions, but only to build an easy computational code to shed light on the stress solution for a general and typical configuration of a jib with its rig.

3.3.1. Finite Element formulation for the mast: beam element

The mast is centred in the boat and stands straight. But is not rigid structure. In fact, to tune the rig or to trim the mainsail or the jib, the mast undergoes usually bending. This bending is one of the control parameters of the sail shape. For example, if the mast bending increases, the draft of the mainsail will decrease, and the sail will be flatter. Therefore, to develop a structural analysis, requires the following mast properties:

- it is a straight structure like a beam with non uniform cross section;
- it can undergo bending.

Then to achieve a structural analysis by the finite element method, it is possible to discretize the mast using beam elements. This because it is capable of resisting:

- axial force;
- bending moments about the two principle axes of its cross-section,
- twisting moment about its centroidal axis,

The mast deflections are smaller than the displacements of the sail and wire, due to its greater rigidity. For this reason, it could be appropriate to develop the beam element matrices for small deflections.

This decision is supported by several studies. In fact, most authors consider the mast to be subject to small displacements or even remain rigid, while a few particular studies have employed a non linear analysis.

Consider a beam element, figure 8, linking the nodes i and j , in the global co-ordinate system (X, Y, Z) . The co-ordinate of each node, will be:

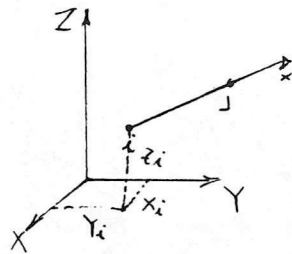

$$i = (X_i, Y_i, Z_i) \quad j = (X_j, Y_j, Z_j).$$

Figure 8: Beam element

Remembering that for a jib and mast configuration there are only three kinds of concentrated loads : bending moment, axial and compression loads, it will be possible to consider 5 degrees of freedom per node, neglecting the rotation about the axial direction and hence torsion.

Considering the local reference co-ordinate system as the Cartesian system (x, y, z) with the x -direction along the beam axis, positive from i to j , the displacement vector of each point on the beam element will be:

$$u = [u(x), v(x), w(x)]^T;$$

Which is the starting point for deriving the stiffness matrix in accordance with the finite element method. Remembering that for a linear analysis, it is possible to add the effects due to different loads, the stiffness matrix will be derived for the beam element considering an axial load, bending moment, and buckling separately

First it is appropriate to develop the beam element matrices for small deflections. The derivation of beam elements stiffness matrix is available in many text books, for example [14] The buckling theory will be developed later.

In the next figures, there will be the deformation shape for the different loads in both cases: 2-dimensional and 3-dimensional.

3.3.2. Finite element formulation for the wires: Cable element

The rig of a jib is composed of the mast and cables. The cables link the sail to the mast to achieve and maintain the chosen sail shape using several links. The main purpose hence is to consider only the structural analysis of the cables, using finite element analysis.

A cable, [3], [17], has only a component of stiffness in the axial or longitudinal direction. The element's behaviour under external load is non-linear, mostly due to change in shape or geometry. In fact, the main sources of non linearity are:

- non-linear material behaviour,
- non-linear geometrical behaviour,
- a combination of both of the above effects.

In the present problem, the cables exhibit non-linear behaviour for the third reason. Then, because their contribution to the equilibrium equation is also non-linear, the following finite

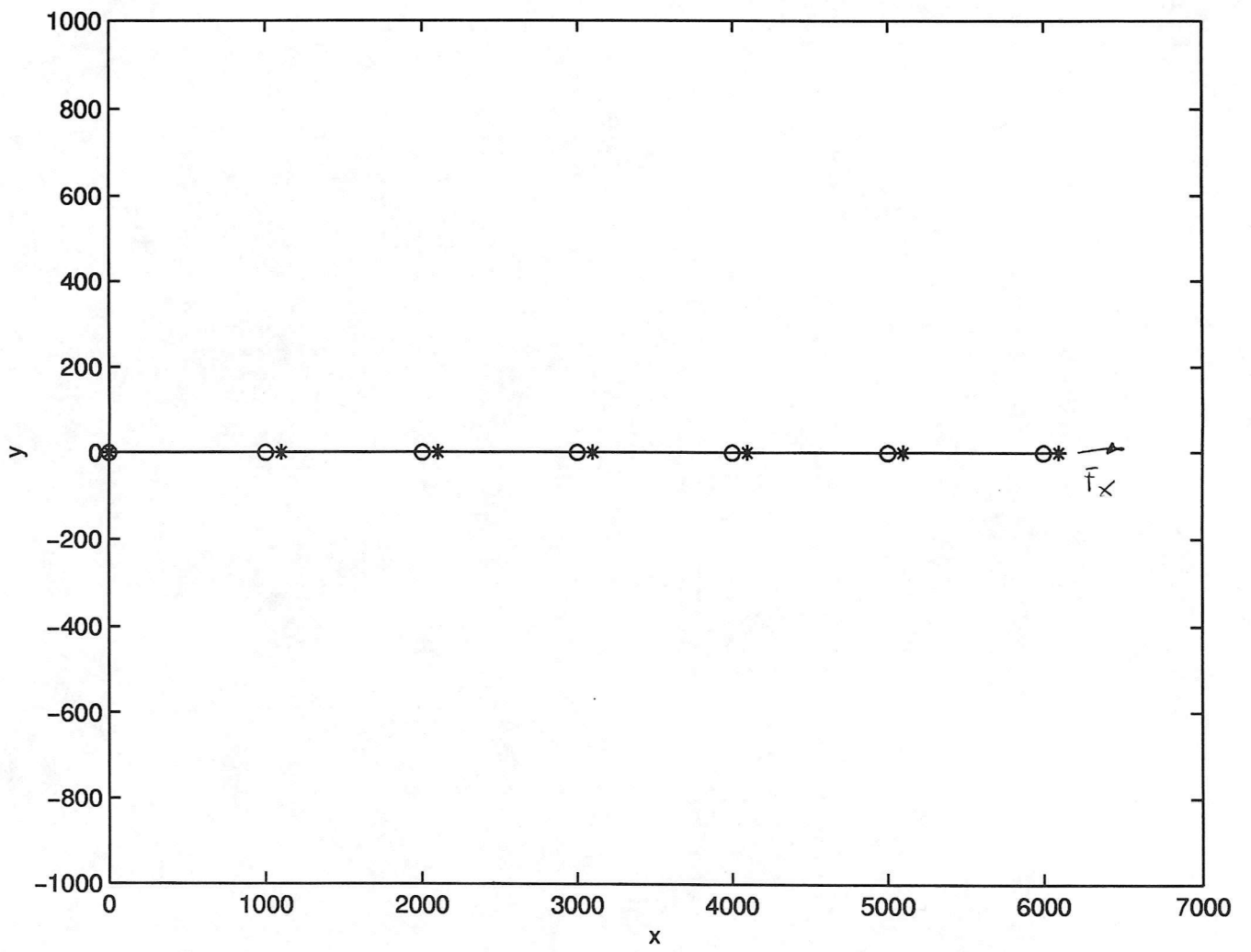

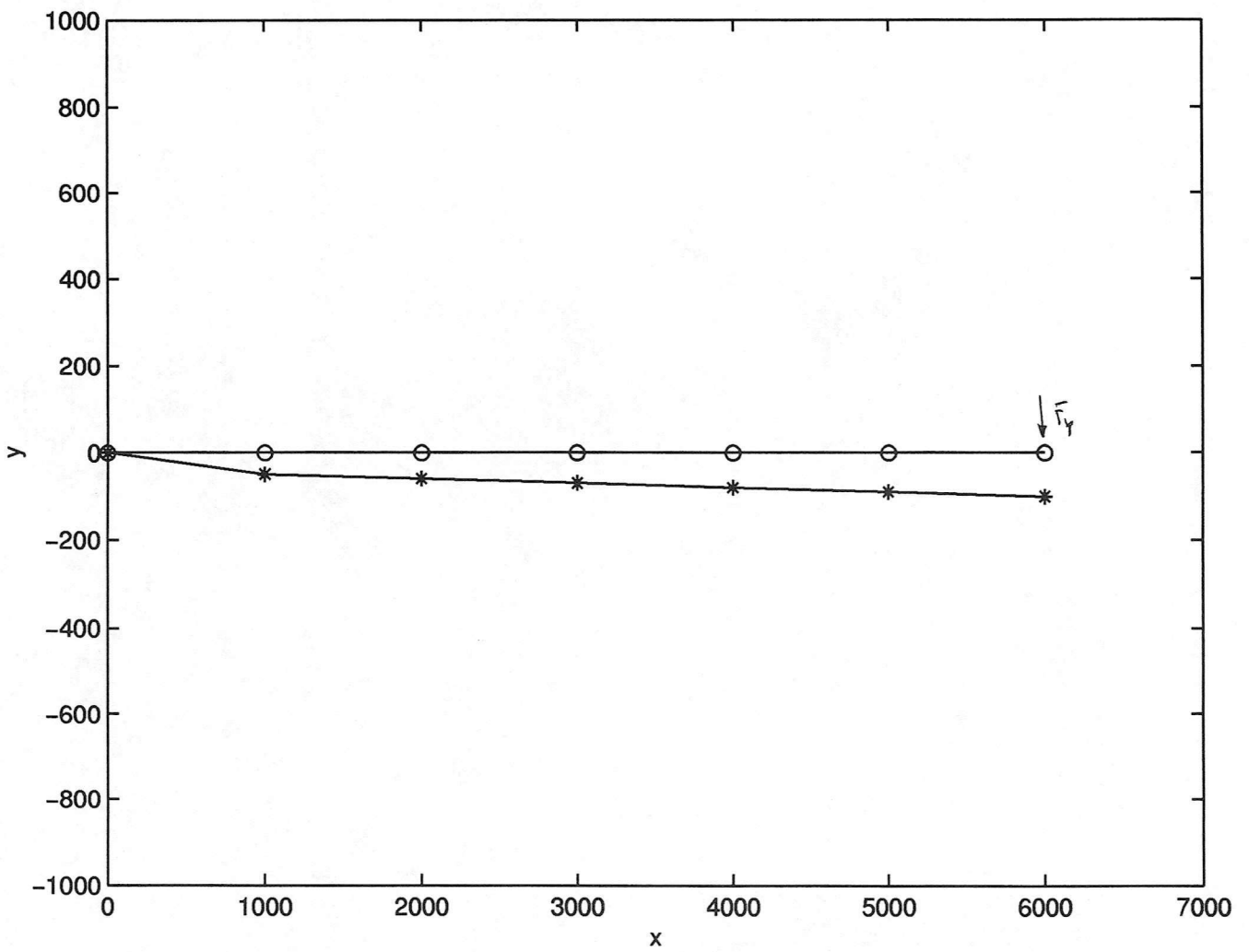

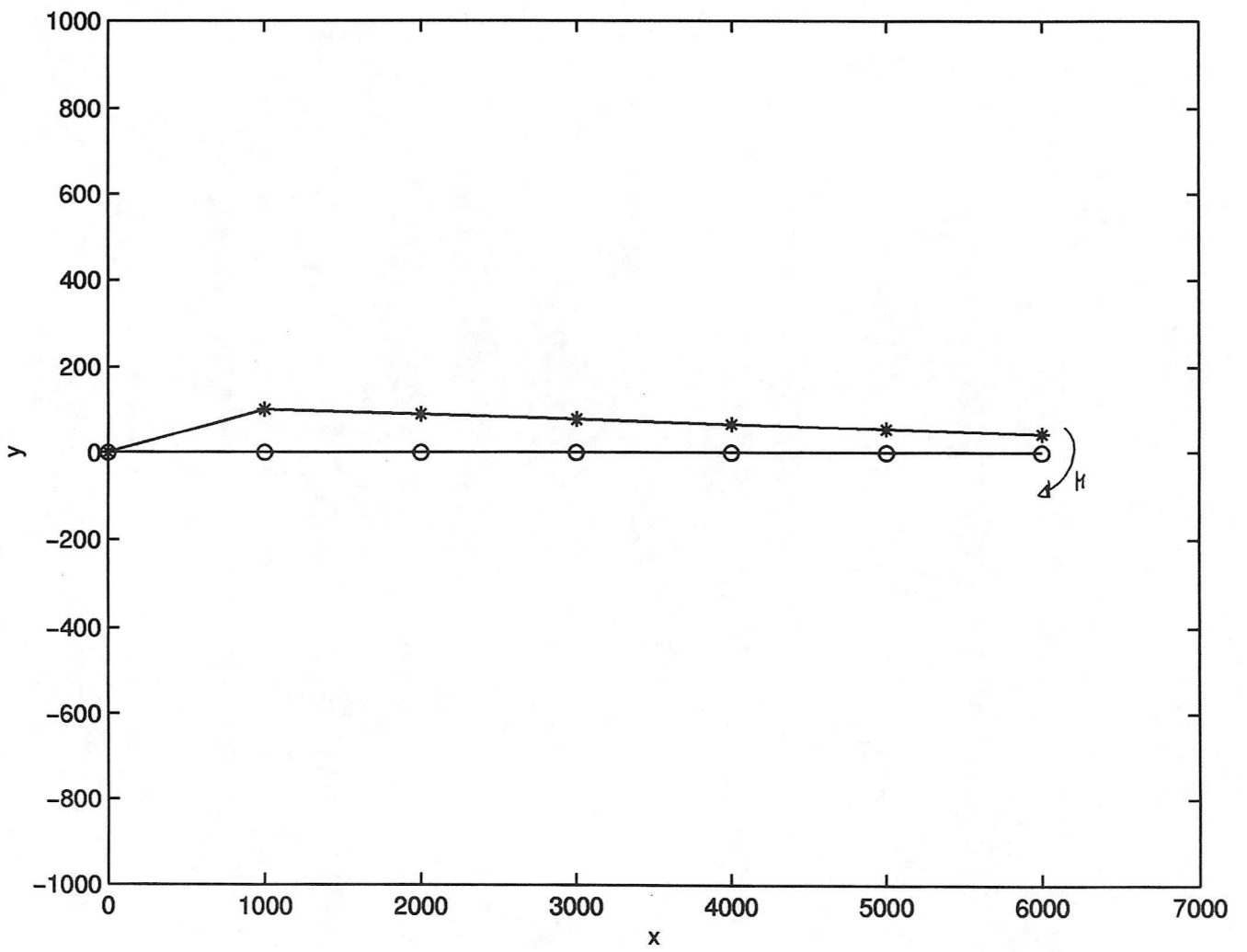

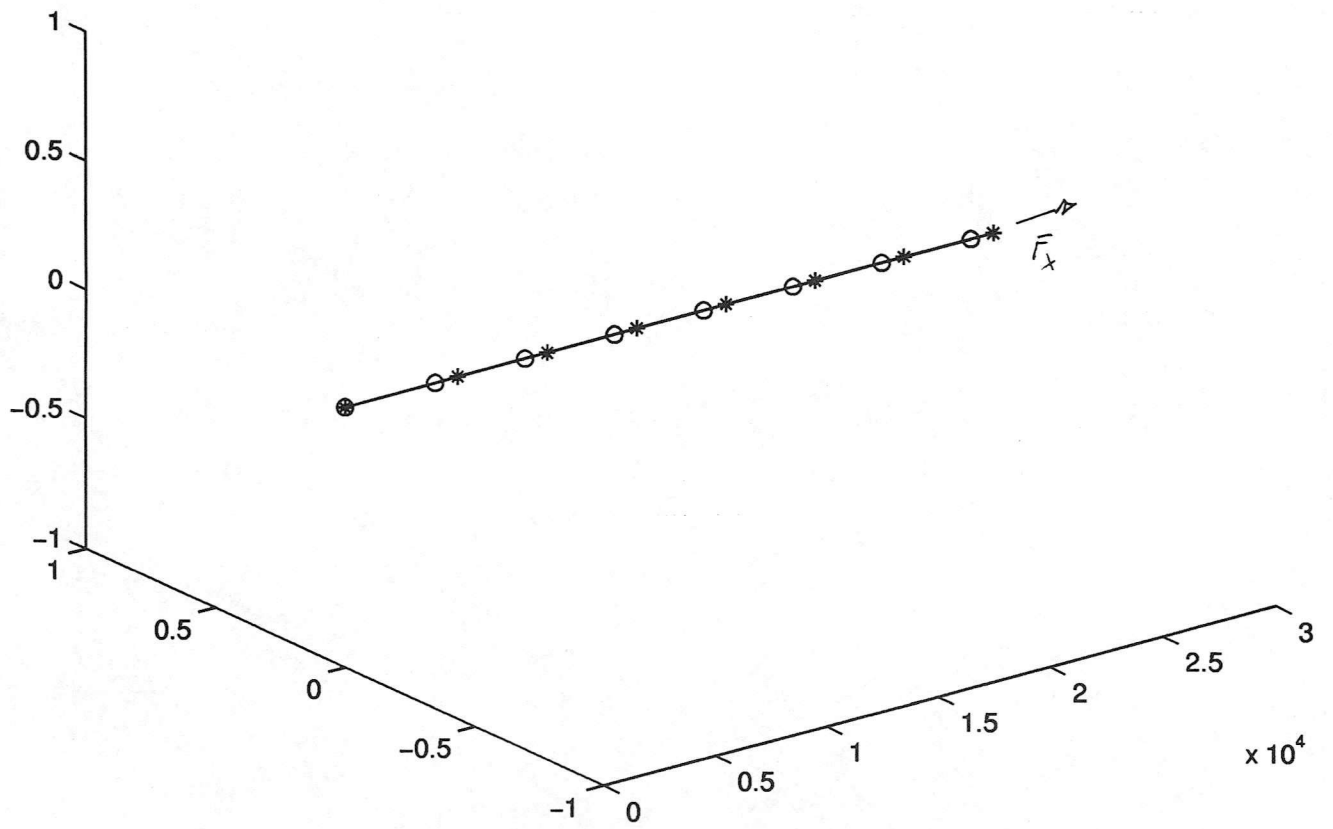

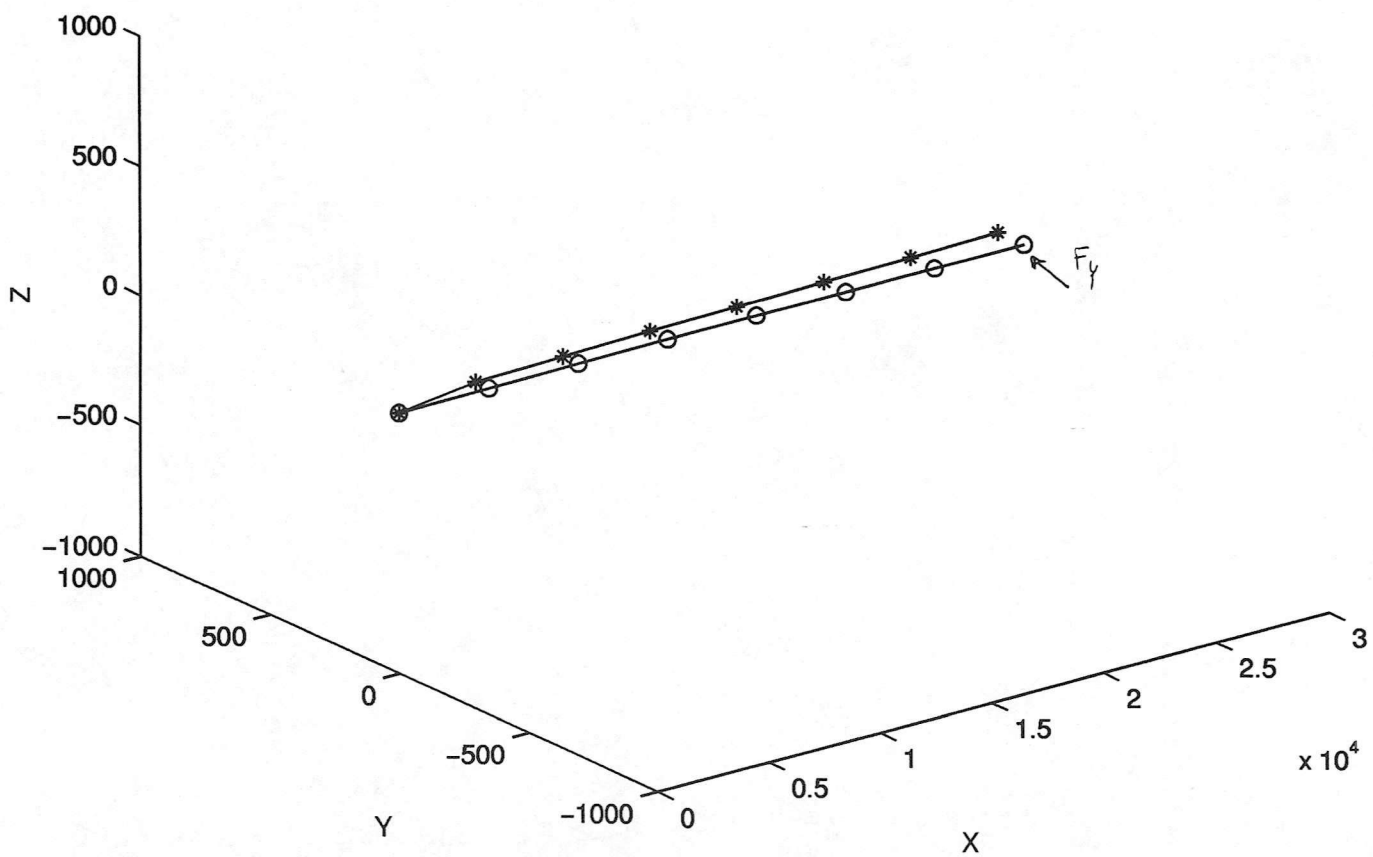

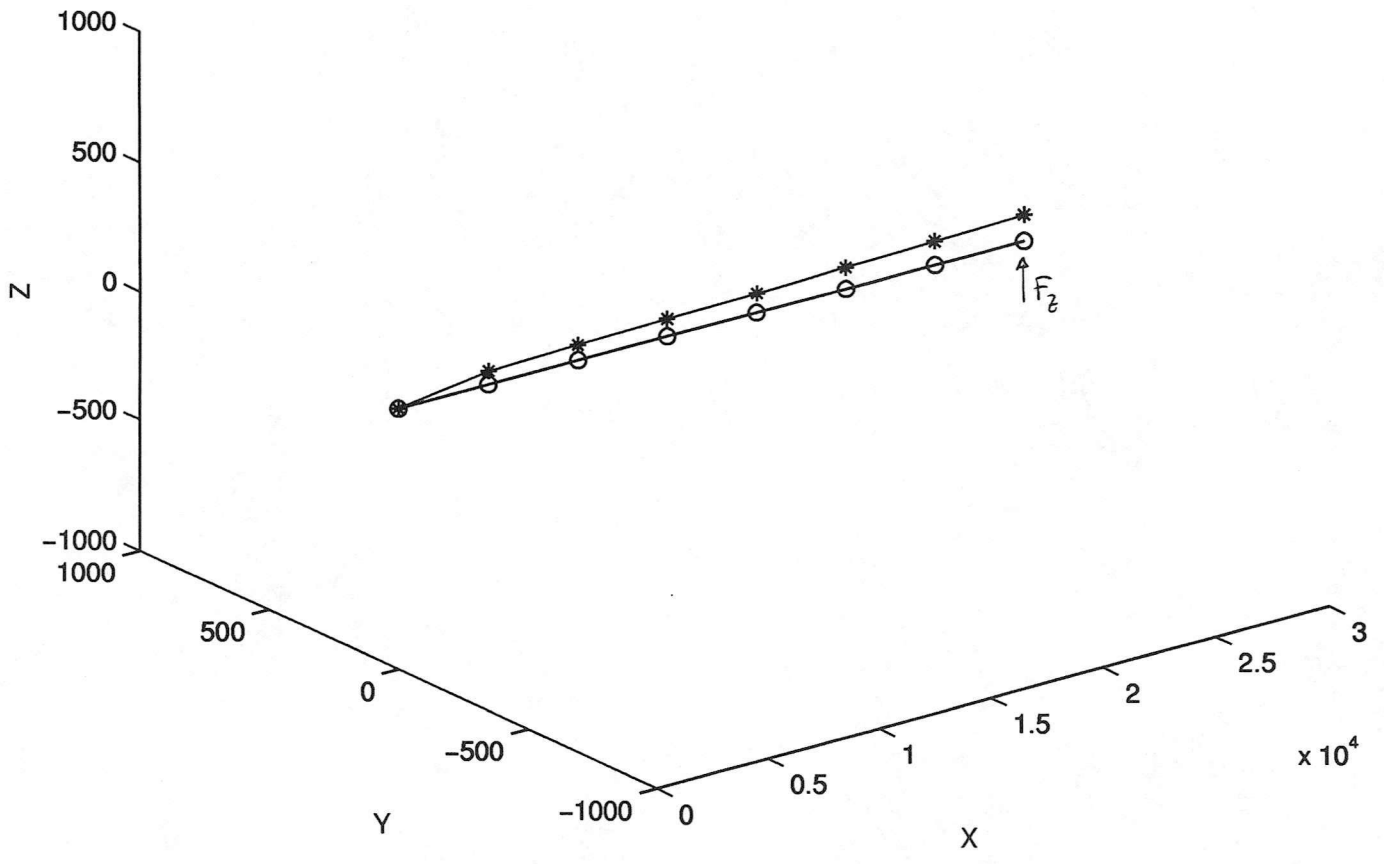

element analysis will be similar to the membrane analysis.

The finite element model uses *cable element*. Consider a cable element connecting nodes *i* and *j*, as in fig 9.

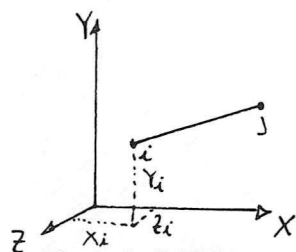

Figure 9: Cable element.

If (X,Y,Z) is the global co-ordinate system, the nodal co-ordinate are:

$$i = (X_i, Y_i, Z_i) \quad j = (X_j, Y_j, Z_j)$$

and their displacement vectors are, in the same system, $[U_i, V_i, Z_i]^T$ and $[U_j, V_j, W_j]^T$.

The definition of the strain along the cable will be:

$$\varepsilon = \frac{l_d - l_0}{l_0}$$

where l_0 represents the length of the cable before the deformation:

$$l_0 = \sqrt{[(X_j - X_i)^2 + (Y_j - Y_i)^2 + (Z_j - Z_i)^2]}$$

while l_d represents the length of the element after the deformation:

$$l_d = \sqrt{[(X_j - X_i + U_j - U_i)^2 + (Y_j - Y_i + V_j - V_i)^2 + (Z_j - Z_i + W_j - W_i)^2]}$$

To find the equilibrium equation for this system, the '*principle of the virtual work*', will be used. The expression for the virtual deformation is:

$$\delta\varepsilon = \left[\begin{array}{l} \frac{X_j - X_i + U_j - U_i}{l_d} \delta(U_j - U_i) + \\ \frac{Y_j - Y_i + V_j - V_i}{l_d} \delta(V_j - V_i) + \\ \frac{Z_j - Z_i + W_j - W_i}{l_d} \delta(W_j - W_i) \end{array} \right] / l_0$$

or in matrix form:

$$\delta\varepsilon = \frac{1}{l_0} B \delta U$$

in which U is the displacement vector of this element in the global co-ordinate system:

$$U = [U_i \quad V_i \quad W_i \quad U_j \quad V_j \quad W_j]^T$$

and B is the matrix of the direction cosines

$$B = [-C_x \quad -C_y \quad -C_z \quad C_x \quad C_y \quad C_z]$$

The direction cosines of the deformed cable, C_x, C_y, C_z , are given by

$$C_x = \frac{X_j - X_i + U_j - U_i}{l_d}$$

$$C_y = \frac{Y_j - Y_i + V_j - V_i}{l_d}$$

$$C_z = \frac{Z_j - Z_i + W_j - W_i}{l_d}$$

For the given environmental of the cable it is possible to use the 'LINEAR ELASTIC CONSTITUTIVE RELATIONS':

$$\sigma = E\varepsilon + \sigma_0$$

where σ_0 is the initial stress of the cable element and E is the Young's modulus.

In a structure composed of cable elements the contribute of this element to the internal virtual work is :

$$\varphi_c = \int_{l_0}^{l_e} \frac{1}{l_0} B^T \sigma A dS = B^T \sigma A;$$

where A is the cross-sectional area and l_e is the length of the cable element.

Recalling the solution of the non-linear equilibrium equations for the membrane element, the stiffness matrix for the cable element will be obtained, linearizing the element equilibrium equations in a similar manner:

$$K_c = \frac{\partial \varphi_c^T}{\partial U} = AB^T \frac{\partial \sigma}{\partial U} + A\sigma \frac{\partial B^T}{\partial U};$$

$$K_c = \frac{EA}{l_0} B^T B + \frac{A\sigma}{l_d} C$$

where

$$C = \begin{bmatrix} C_y^2 + C_z^2 & 0 & 0 & -C_y^2 - C_z^2 & 0 & 0 \\ 0 & C_x^2 + C_z^2 & 0 & 0 & -C_x^2 - C_z^2 & 0 \\ 0 & 0 & C_x^2 + C_y^2 & 0 & 0 & -C_x^2 - C_y^2 \\ -C_y^2 - C_z^2 & 0 & 0 & C_y^2 + C_z^2 & 0 & 0 \\ 0 & -C_x^2 - C_z^2 & 0 & 0 & C_x^2 + C_z^2 & 0 \\ 0 & 0 & -C_x^2 - C_y^2 & 0 & 0 & C_x^2 + C_y^2 \end{bmatrix}$$

This is composed of two terms: the first is the same as the linear analysis (considering small displacement theory), while the second contains the non-linear effect due to the large variation of the length (or geometry), which can not be neglected.

Once the stiffness matrix for each element has been obtained assembly into the stiffness matrix for the entire system is performed and the iterative solution is incremented

The following diagrams show the deformed shape for a simple cable structure.

Figure 10 shows the coupled model that will be analysed.

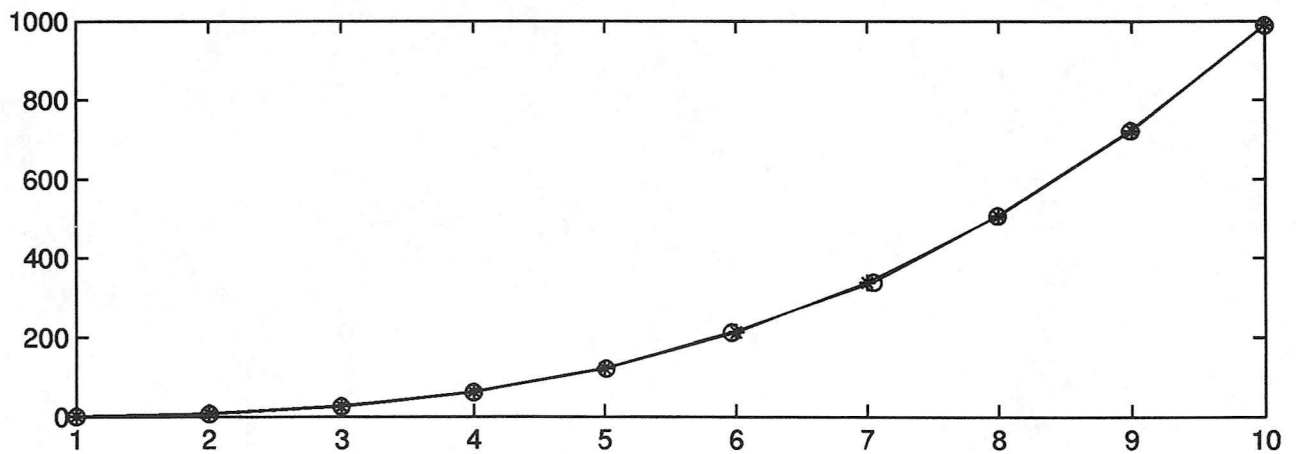
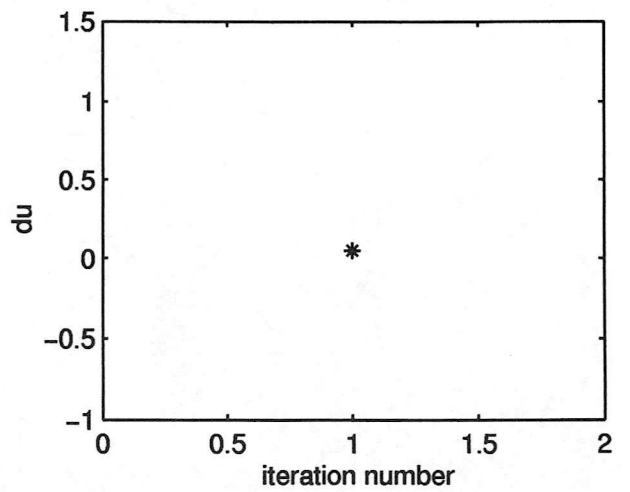
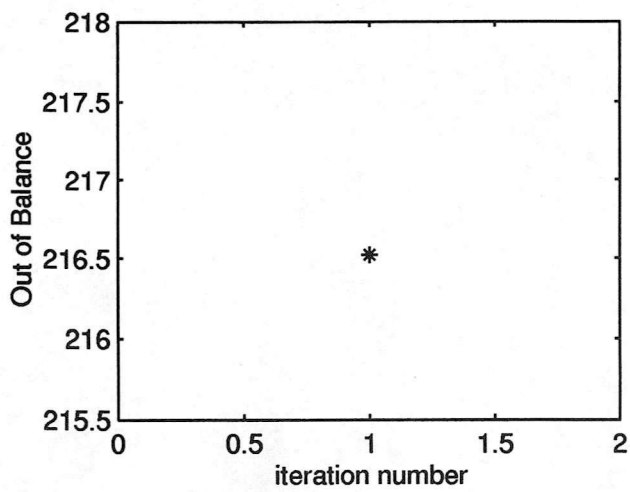

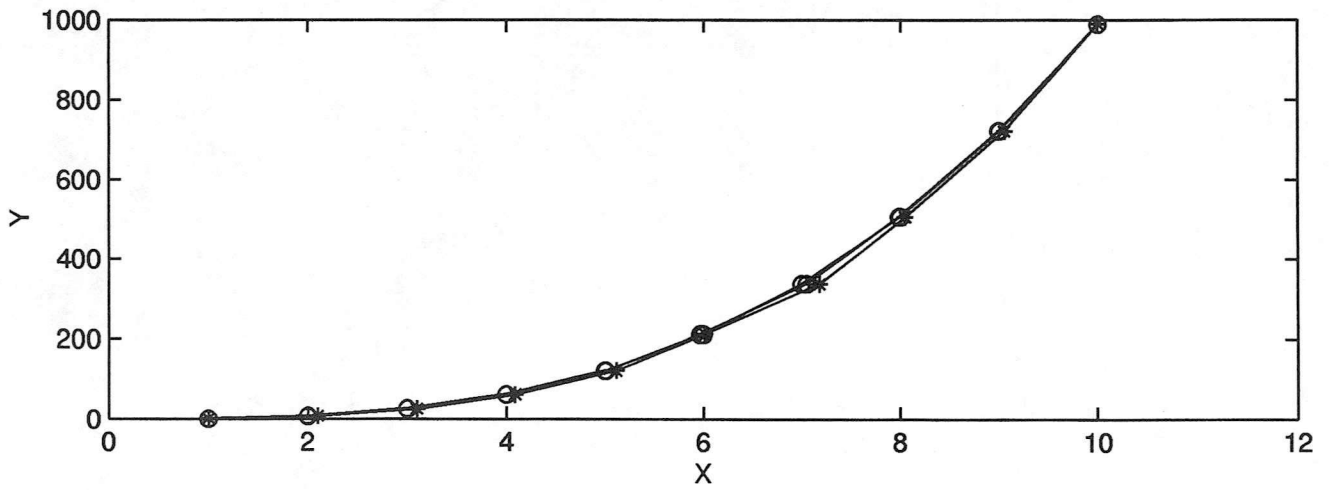
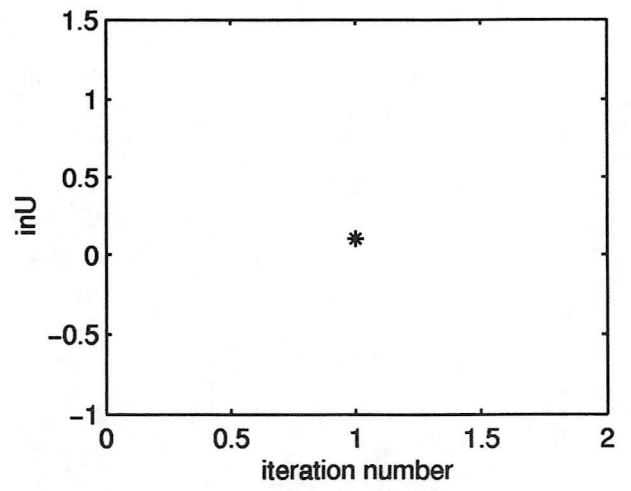
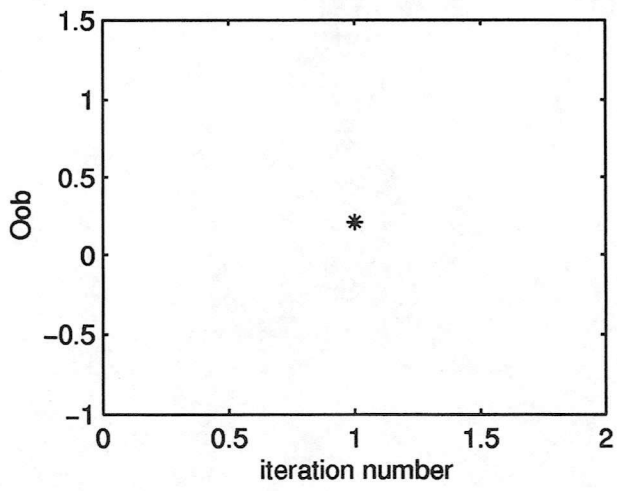

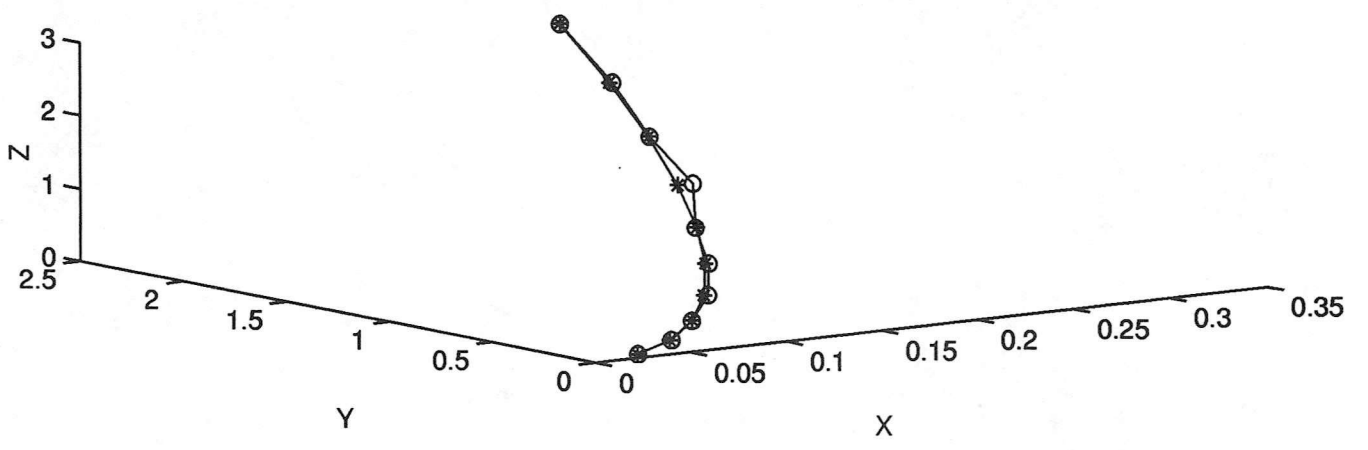
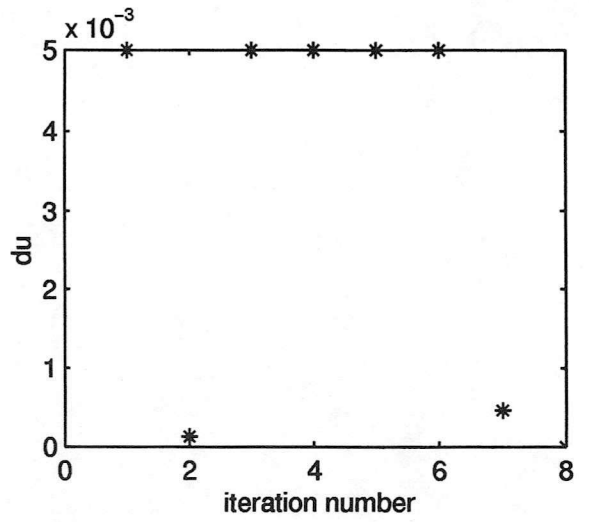
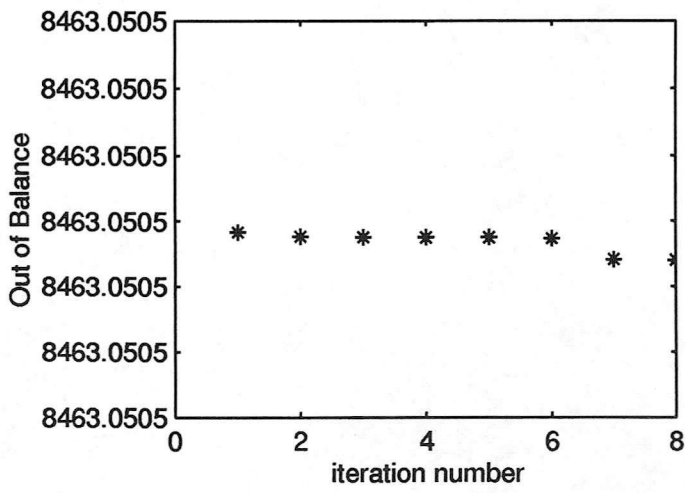

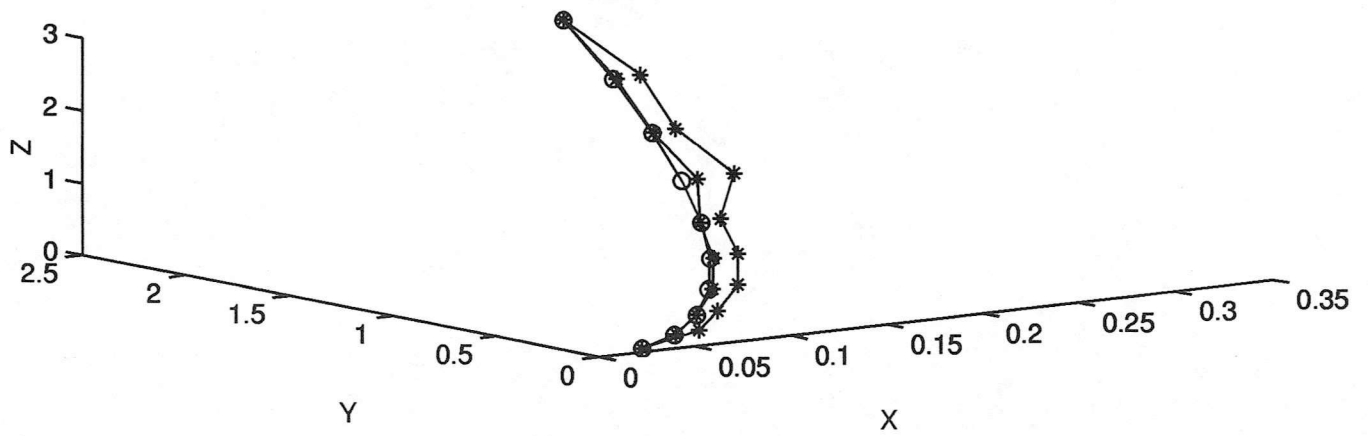
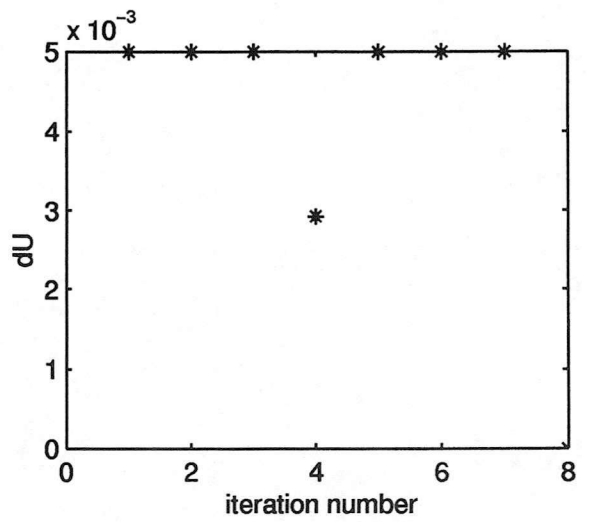
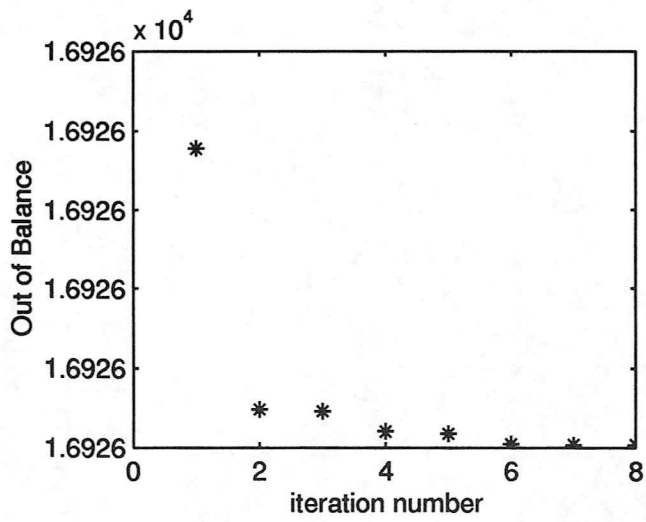

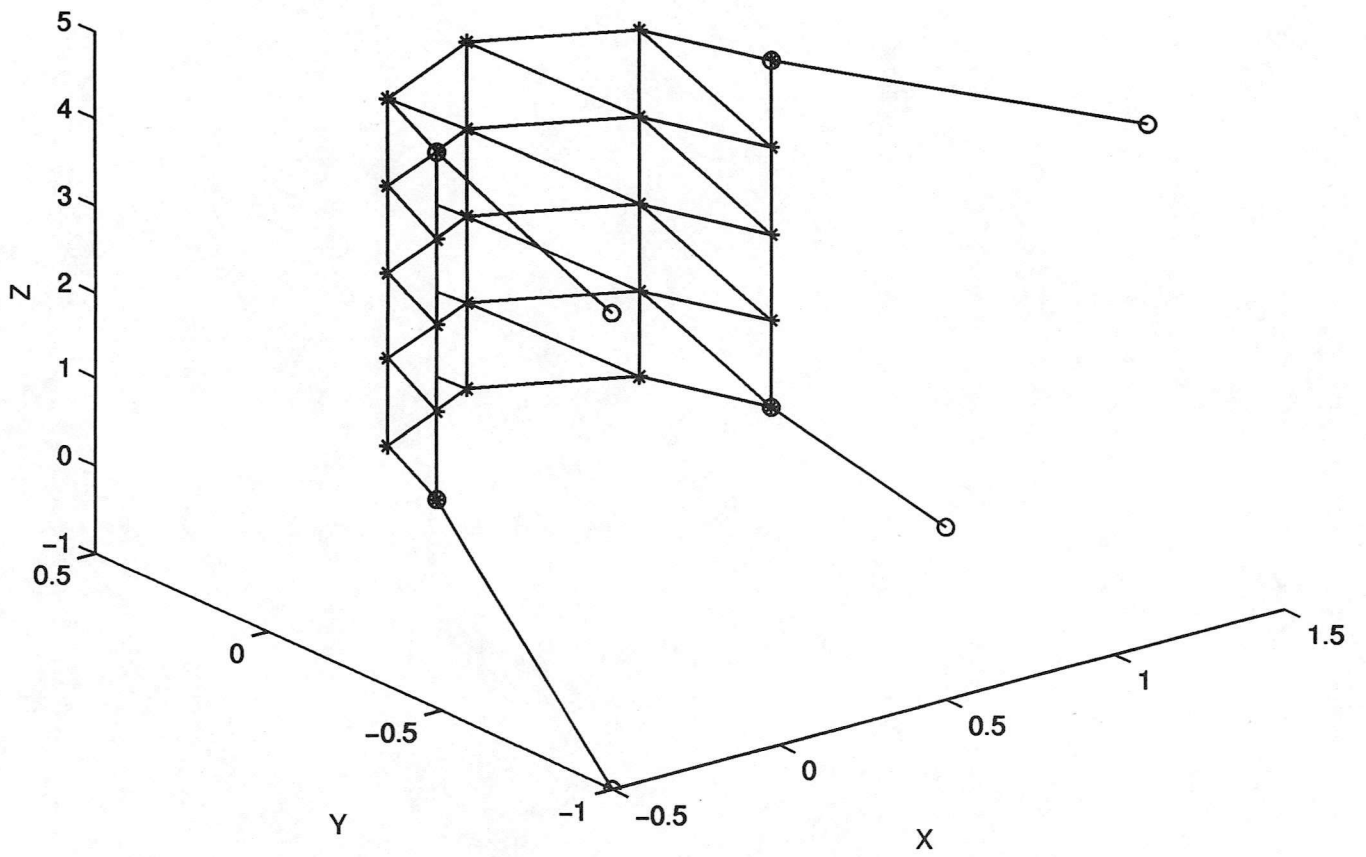

FIGURE 10 : MEMBRANE + CABLE

4. Conclusion

A simple configuration composed of a jib, mast and its rig has been considered. For each of these elements the structural analysis has been performed using the finite element method. To develop the analysis it became necessary to build the geometrical shape and the finite element model. In the first step the geometrical model used was a semicylindrical shaped surface for the sail. The result obtained so far show some problems concerned the iteration method used.

So it will be necessary to do the same analysis using a commercial software packages to validate the structural analysis performed.

REFERENCES

- [1] ANDRESEN T., 1981, Geometry of sailmaking, *Chesapeake Sailing Yatch Symposium Annapolis*, 29-36.
 - [2] BOOTE D. and CAPONETTO M., 1991, A numerical approach to the design of sailing yatch masts, *The tenth Chesapeake Sailing Yatch Symposium*, 59-81.
 - [3] BROUGHTON P. and NDUMBARO P., 1994, The analysis of cable catenary structures, *Thomas Telford books*
 - [4] BYOUNG K. C., HA-YONG S. and WOO S. Y., 1993, Visually smooth composite surfaces for an unevenly spaced 3D data array, *Computer Aided Geometric Design*, **10**, 157-171.
 - [5] CHEUNG Y. K. and YEO M. F. A practical introduction to finite element analysis, *A Pitman International Text*.
 - [6] FAUX I. D. and PRATT M. J., 1979, Computational geometry for design and manufacture, *Ellis Horwood Limited Publishing*, **5**, 126-152, **7**, 198-239.
 - [7] FUKASAWA T., MASANOBU K., 1993, Numerical approach to aeroelastic responses of a three-dimensional flexible sails, *The eleventh Chesapeake Sailing Yatch Symposium*, 87-105.
 - [8] GREELEY D. S., KIRKMAN K.L., DREW A. L. and CROSS-WHITER J., 1989, Scientific sail shape design, *The Ninth Chesapeake Sailing Yatch Symposium*, 33-80.
 - [9] JACKSON P.S., 1985, The analysis of three-dimensional sails, *Proceeding of the Tenth Canadian Congress of Applied Mechanics*.
 - [10] LARSSON L., 1990, Scientific methods in yatch design, *Annual Reviews Inc.*, **22**, 349-385.
 - [11] MILGRAM J. H., 1993, Naval architecture technology used in winning the 1992 America's cup match, *SNAME Transactions*, **101**, 339-436.
 - [12] MUTTIN F., 1991, Structural analysis of sails, *Eur. J. Mech A/Solids*, **10**, 517-534
 - [13] OOSSANEM P., 1993, Predicting the speed of sailing yachts, *SNAME Transactions*, **101**, 337-397.
 - [14] RAO S. S., 1989, The finite element method in engineering, 2nd Edition, *Pergamon Press*, Oxford.
 - [15] SPRANGER J., 1995, Speed and stamina, *The new book of sail trim*, *Adlard Coles Nautical*
 - [16] STASA F. L. 1985, Applied finite element analysis for engineers, HRW, N.Y, **7**, Section 5
 - [17] TABARROK B. and QIN Z., 1991, Non linear analysis of tension structures, *Computers & Structures*, **45**, No 5/6 973-984.
 - [18] WIDDEN T. and LEVITT M., *The art and science of sail*
- For more details the following web site are:
- [19] NORTH SAILS WEB SITE: <http://www.ns.italia@pn.itnet.it>
 - [20] UK SAILMAKER
 - [21] WB.SAIL: <http://www.marnet.fi@wb.sails.imet.fi>

