



UNIVERSITAT POLITÈCNICA DE CATALUNYA  
BARCELONATECH

Departament de Ciència i Enginyeria  
Nàutiques

# **Semantic Interoperability Assessment**

## **iShare Framework**

**Fernando Sérgio Bryton Dias Marques, MSc**

Thesis submitted for the degree of Doctor from the  
Universitat Politècnica de Catalunya. BARCELONATECH

Nautical Sciences and Engineering Doctoral Program  
Department of Nautical Sciences and Engineering

Barcelona. June 1<sup>st</sup>, 2018.

Supervisors

**Jesús E. Martínez Marín, PhD**

Department of Nautical Sciences and Engineering, Universitat Politècnica de Catalunya, Spain

**Olga Delgado Ortega, PhD**

Department of Marine Engineering. Nautical College Infante D. Henrique, Portugal



To my beloved wife and daughters, Sandra, Joana and Sofia.

*“Eles não sabem, nem sonham,  
que o sonho comanda a vida,  
que sempre que um homem sonha  
o mundo pula e avança  
como bola colorida  
entre as mãos de uma criança”*

António Gedeão. A Pedra Filosofal. In Movimento Perpétuo, 1956



## Acknowledgments

This work would not have been possible without the support and collaboration of other people. I am privileged for being surrounded by remarkable persons in life, and now is the time and place to acknowledge and thank the interest and kindness of all those that, in one way or the other, took some of their valuable time to offer me from the simplest and warmest word to the most important advice.

Thank you, Sandra, Joana and Sofia, for trusting and supporting me for so long in achieving this objective. Thank you for caring and being so patient, especially when this work stole so much family time from us. And only because it was important to me. Certainly, that time will never come back, but I am sure this experience has made us stronger, brought us closer and made us better persons.

Thank you, Maria Armanda, for being my mother. The role and importance of a mother in the life of its children is unique, and can never be sufficiently described or thanked for, let alone in a few lines. So, allow me to keep it simple, yet meaningful and heartfelt. Children do not get to pick their mothers, so I am sure I was very lucky.

Thank you, Anacleto Correia, André Silva, António Gameiro Marques, António Sempiterno Ribeiro, Bernardo Mota, David Berger, Eduardo Fonseca, Fabrizio Natale, Franco Oliveri, Gian Carlo Pace, Guido Ferraro, Harm Greidanus, Isabel Dourado, Jesús Hermida, João Fonseca Ribeiro, Luís Arsénio, Luís Silva, Manuel Costa, Marco Scipioni, Marion Westra, Paula Madeira, Pedro Mendonça das Neves, Ricardo Alves, Sandra Coutinho, Sara Grubanov, Sandra Silva, Silvia Migali and Teresa Mira. I am very fortunate for having you as friends.

Thank you, Jesús Martínez Marín and Olga Delgado for your supervision. I will never be able to express my gratitude in words. Let me just say that, under your supervision, I would do this all over again.

Last, but not least, a big thank you, to all those that participated in the NIPIMAR project and related initiatives. More than supporting this research, your work has brought Portugal a step closer to better govern its ocean. And you, maybe better than anyone, know how important this is for present and future generations.

(page intentionally left in blank)

## **Abstract**

Interagency information sharing is widely acknowledged for increasing the efficiency and effectiveness of several domains with high societal impact such as security, cybersecurity and health. Therefore, it comes as no surprise that the development of interoperability among public services is a political priority in many countries around the world, and that, presently, several initiatives are ongoing with this purpose.

The proper management of such initiatives demands adequate instruments to support the definition of the existing (as-is) and desired (to-be) situations, as well as the identification, prioritization, monitoring and control of the actions that are necessary to achieve the objectives defined for developing interoperability. Moreover, appropriate instruments are also required to support the justification and comparison of initiatives, for example in situations where they compete for funds. However, the existing practical solutions are scarce and do not fit well these requirements.

Therefore, this research proposes a framework (iShare) for assessing the semantic interoperability - one of the facets of interoperability - of governmental agencies that use a common information model for exchanging information with each other. This assessment is made in two parts. The first part assesses how organizations are performing, in terms of semantic interoperability, and the second part assesses the relevance of that performance, considering a series of pre-defined factors.

To develop the iShare framework we followed the Design Science Research Method. The framework itself is based on Process Performance Indicators, on the Delphi Method and on the Weighted Sums Model. Its validation was performed during the development of the Portuguese maritime surveillance information exchange system (NIPIMAR), which is based on the information model of the European Maritime Common Information Sharing Environment (CISE).

The result of the validation was the assessment of the semantic interoperability of six public organizations participating in the project. In addition, some of the main ideas of the framework were immediately used within the project to assess the semantic interoperability of all organizations that were participating in it and to develop an action plan to improve their interoperability and information exchange.

The iShare framework has thus proven to be an innovative, useful, relevant and more objective way of assessing semantic interoperability among various organizations, which tells us how much and how relevant that interoperability is. Hence, the iShare framework contributes to the body of knowledge in the field and opens new possibilities for assessing interoperability and information exchange, and thus to increase the efficiency and effectiveness of governmental agencies.

**Keywords** *Information Exchange, Semantic Interoperability, Performance, Relevance, Maritime Surveillance, Maritime Security.*

(page intentionally left in blank)



*“The culture of agencies feeling they own the information they gathered at taxpayer expense must be replaced by a culture in which the agencies instead feel they have a duty to the information - to repay the taxpayers’ investment by making that information available.”*

(Kean & Hamilton, 2004)

(page intentionally left in blank)

# Index

Acknowledgments .....	1
Abstract .....	3
Index .....	7
List of figures .....	13
List of tables .....	15
Acronyms and abbreviations .....	21
Introduction .....	27
PART I – Background.....	42
1 Political and legal .....	44
1.1 Strategies and policies .....	44
1.1.1 EU Integrated Maritime Policy .....	44
1.1.2 EU Maritime Security Strategy .....	44
1.1.3 EU Agenda on Migration.....	46
1.1.4 EU Agenda on Security .....	46
1.1.5 EU eHealth Action Plan.....	47
1.1.6 EU Interoperability Strategy.....	49
1.1.7 US Strategy for Information Sharing and Safeguarding .....	49
1.2 Projects and programmes .....	50
1.2.1 EU Maritime Common Information Sharing Environment.....	50
1.2.2 EU Interoperability Framework .....	51
1.2.3 US Information Sharing Environment.....	53
2 Scientific.....	56
2.1 Information sharing benefits.....	56
2.1.1 Political.....	57
2.1.2 Organizational .....	58
2.1.3 Technical .....	60
2.2 Semantic interoperability.....	60
2.2.1 Concepts .....	60

2.2.2	Benefits.....	61
2.2.3	Applications.....	63
2.2.4	Challenges .....	68
2.2.5	Techniques and technologies.....	72
PART II – Material and methods .....		83
3	Research organization.....	85
3.1	Research process.....	85
3.2	Research questions, hypothesis and objectives .....	86
3.3	Research strategy.....	87
3.3.1	Problem identification .....	90
3.3.2	Objectives definition.....	91
3.3.3	Design and development .....	92
3.3.4	Demonstration and evaluation .....	97
PART III – Results and analysis .....		101
4	Conceptual model.....	103
4.1	Overview .....	103
4.1.1	Why use it?.....	103
4.1.2	When to use it? .....	109
4.2	Conceptualization of the performance indicators .....	115
4.2.1	Objectives .....	116
4.2.2	Effectiveness objectives.....	116
4.2.3	Efficiency objectives .....	116
4.2.4	Quality objectives .....	117
4.2.5	Process identification.....	117
4.2.6	Identification of the representation-targets.....	120
4.2.7	Analysis and testing of the representation-targets .....	121
4.3	Conceptualization of the relevance indicators .....	122
4.3.1	Objectives .....	122
4.3.2	Effectiveness objectives.....	122
4.3.3	Efficiency objectives .....	122

4.3.4	Quality objectives.....	122
4.3.5	Process and representation-targets.....	123
5	Core concepts .....	124
5.1	Performance.....	124
5.1.1	Participants .....	124
5.1.2	Common Information Model.....	125
5.1.3	Information systems .....	125
5.1.4	Information transformations.....	127
5.1.5	Information available .....	130
5.1.6	Information needed.....	133
5.1.7	Information required.....	134
5.1.8	Information mapped .....	136
5.1.9	Information to be provided.....	141
5.1.10	Information to be consumed.....	153
5.2	Relevance .....	167
5.2.1	Factors, weight and relevance .....	167
5.2.2	Other concepts.....	170
6	Indicators definition .....	173
6.1	Performance indicators.....	173
6.1.1	Information available .....	174
6.1.2	Information required.....	175
6.1.3	Information mapped .....	176
6.1.4	Information to be provided.....	178
6.1.5	Information to be consumed.....	181
6.2	Relevance indicators.....	183
6.2.1	Information available .....	184
6.2.2	Information required.....	185
6.2.3	Information mapped .....	185
6.2.4	Information to be provided.....	187

6.2.5	Information to be consumed .....	189
7	Demonstration .....	193
7.1	Preparation.....	193
7.1.1	Questionnaire design .....	193
7.1.2	Software application.....	200
7.1.3	Preparation of the experts .....	201
7.2	Execution.....	201
7.2.1	Data collection.....	201
7.2.2	Data quality .....	202
7.2.3	Data calculations.....	202
7.2.4	Harmonization of the results.....	203
7.3	Results and evaluation.....	203
7.3.1	Characterizing the situation.....	203
7.3.2	Improving the semantic interoperability.....	208
7.3.3	Evaluation.....	232
	Conclusions .....	237
	References .....	243
	Appendixes .....	270
	Appendix 1. Information sharing scenario .....	272
	Appendix 2. Core concepts.....	274
	Performance.....	274
	Participants .....	274
	Common Information Model.....	274
	Information systems .....	275
	Information transformations .....	276
	Information available.....	277
	Information needed.....	280
	Information required.....	281
	Information mapped .....	283
	Information to be provided .....	286

Information to be consumed.....	293
Relevance .....	299
Factors, weight and relevance .....	299
Other concepts.....	300
Appendix 3. Performance Indicators.....	306
Information available .....	306
Information required.....	307
Information mapped .....	308
Information mapped for provisioning .....	308
Information mapped for consumption .....	309
Information to be provided.....	310
Information that could be provided (baseline) .....	310
Information that should be provided (potential performance).....	311
Information that must be provided (actual performance).....	312
Information to be consumed.....	313
Information that could be consumed (baseline) .....	313
Information that should be consumed (potential performance).....	314
Information that must be consumed (actual performance).....	315
Appendix 4. Relevance Indicators.....	316
Information available .....	316
Information required.....	317
Information mapped .....	318
Information mapped for provisioning .....	318
Information mapped for consumption .....	319
Information to be provided.....	320
Information that should be provided .....	320
Information that must be provided .....	321
Information to be consumed.....	322
Information that should be consumed .....	322

Information that must be consumed .....	323
Appendix 5. Assessment of the scenario .....	324
Parameters .....	324
Systems performance and relevance.....	324
Dashboard example .....	327
Appendix 6. Questionnaire submitted (digital version also) .....	330
Part I - Introduction .....	332
Part II - Instructions.....	333
Part III - Questions .....	334
Appendix 7. Software application (digital version only).....	335
Appendix 8. Scenario original data (digital version also) .....	337
Appendix 9. Scenario calculated data (digital version also).....	339
Appendix 10. NIPIMAR original data (digital version only).....	341
Appendix 11. NIPIMAR calculated data (digital version only) .....	343
Appendix 12. Information to be exchanged (digital version only).....	345
Appendix 13. Information elements per project (digital version only) .....	347
Annexes .....	349
Annex A. Permission for data and information access and usage .....	351



## List of figures

Figure 1: Data, information, knowledge and wisdom .....	29
Figure 2: Information sharing driving and restraining forces.....	31
Figure 3: The EIF four layers of interoperability .....	36
Figure 4: The iterative and incremental development of semantic interoperability .....	40
Figure 5: Model of the research process .....	85
Figure 6: Design Science Research Criteria.....	88
Figure 7: Design Science Research methods evolution .....	89
Figure 8: Main activities of the Design Science Research Method (DSRM).....	90
Figure 9: Information sharing scenario .....	93
Figure 10: Process used to define and test the indicators .....	95
Figure 11: CISE common information model - Main information entities .....	98
Figure 12: CISE common information model - Complimentary information entities .....	99
Figure 13: How the iShare framework fosters information sharing .....	103
Figure 14: Developing awareness on semantic interoperability.....	105
Figure 15: Developing cost-effective interoperability.....	107
Figure 16: Developing reusable interoperability.....	108
Figure 17: Agile process for improving semantic interoperability.....	110
Figure 18: The typical strategy components.....	112
Figure 19: The RBM lifecycle.....	113
Figure 20: Process used to define and test the indicators .....	116
Figure 21: Relationship between the framework's and the performance indicators' objectives .....	117
Figure 22: Information sharing high-level process .....	118
Figure 23: Relationship between the framework's and the relevance indicators' objectives .....	123
Figure 24: Relationship of the different dimensions (example) .....	142
Figure 25: Relationship of the performance assessed at different levels (example) .....	143
Figure 26: Relationship of the different consumption dimensions (example) .....	154
Figure 27: Relationship of the performance assessed at different consumption levels (example).....	155
Figure 28: Questionnaire part I - Introduction .....	194
Figure 29: Questionnaire part II - Instructions .....	195
Figure 30: Questionnaire part III - Questions.....	197
Figure 31: Information sharing in maritime surveillance.....	198
Figure 32: Data processing tools and activities.....	200
Figure 33: Risks addressed by each organization.....	204
Figure 34: Number of risks addressed by each organization.....	205
Figure 35: Number of systems available, with relevant information, per organization .....	206

Figure 36: Overall information needs and availability .....	207
Figure 37: Information needs and availability per organization.....	208
Figure 38: System elements available per system .....	210
Figure 39: Relevance of the systems considering the information available .....	210
Figure 40: System elements required per system .....	212
Figure 41: Relevance of the systems considering the information required.....	212
Figure 42: System elements available and that could/should be provided per system.....	214
Figure 43: Relevance of the systems considering the information available and that could/should be provided.....	214
Figure 44: System elements available and that could/should be consumed per system.....	216
Figure 45: Relevance of the systems considering the information available and that could/should be consumed.....	217
Figure 46: Number of information elements that should be exchanged per system.....	218
Figure 47: Number of information elements that should be consumed per intervals of relevance .....	220
Figure 48: Minimum number of elements per project to involve all organizations .....	222
Figure 49: Number of elements each organization should consume per project.....	223
Figure 50: Total number of elements to consume per project .....	224
Figure 51: Relevance of the elements consumed per organization per project .....	225
Figure 52: Relevance of the elements consumed per organization per project .....	226
Figure 53: Final number of elements to be consumed per organization per project.....	226
Figure 54: Number and relevance of elements to consume per program .....	228
Figure 55: Average relevance of the elements to consume per program .....	229
Figure 56: Evolution of the number of elements consumed per organization.....	230
Figure 57: Evolution of the relevance of the information consumed per organization .....	232
Figure 58: Systems relative performance and relevance .....	327
Figure 59: Systems performance as provider and consumer .....	329
Figure 60: Systems relevance as provider and consumer.....	329

## List of tables

Table 1: Common problem properties which justify employing the Delphi method .....	95
Table 2: Scenarios total estimated economic benefit (M €) per risk considered .....	100
Table 3: Accessory properties.....	122
Table 4: Participants .....	125
Table 5: Elements of the Common Information Model.....	125
Table 6: Systems of a participant.....	126
Table 7: All systems .....	127
Table 8: Transformation services of a participant .....	128
Table 9: All transformation services.....	128
Table 10: Transformation of a system element into a CIM element.....	129
Table 11: Transformation of a CIM element into a system element.....	129
Table 12: Functions of a transformation service .....	130
Table 13: CIM elements available in a system.....	130
Table 14: CIM elements available in a participant.....	131
Table 15: CIM elements in all systems.....	131
Table 16: System elements available in a system.....	132
Table 17: Participant systems' elements.....	132
Table 18: CIM elements required by a participant .....	133
Table 19: CIM elements needed by all participants .....	133
Table 20: CIM elements required by a participant .....	134
Table 21: CIM elements required by a system .....	135
Table 22: System elements required by a system.....	135
Table 23: System elements required.....	136
Table 24: CIM elements mapped for provisioning by a participant .....	137
Table 25: CIM elements mapped for provisioning by a system.....	137
Table 26: System elements mapped for provisioning.....	138
Table 27: System elements mapped for provisioning by a participant.....	138
Table 28: CIM elements mapped for consumption by a participant.....	139
Table 29: CIM elements mapped for consumption by a system.....	139
Table 30: System elements mapped for consumption .....	140
Table 31: System elements mapped for consumption by a participant .....	141
Table 32: CIM elements that could be provided by a system.....	144
Table 33: CIM elements that could be provided by a participant.....	145
Table 34: System elements that could provide information to other systems .....	146
Table 35: Participant systems' elements that could provide information to other systems .....	147

Table 36: CIM elements that should be provided by a system.....	147
Table 37: System elements that should be provided by a participant.....	148
Table 38: System elements that should be provided.....	149
Table 39: System elements that should be provided by a participant.....	150
Table 40: CIM elements that must be provided by a system.....	151
Table 41: CIM elements that must be provided by a participant.....	151
Table 42: System elements that must be provided by a system.....	152
Table 43: System elements that must be provided by a participant.....	153
Table 44: CIM elements that could be consumed by a system.....	156
Table 45: CIM elements that could be consumed by a participant.....	157
Table 46: System elements that could consume from other systems.....	158
Table 47: Participant systems' elements that could consume from other systems .....	159
Table 48: CIM elements that should be consumed by a system.....	160
Table 49: CIM elements that should be consumed by a participant.....	161
Table 50: System elements that should be consumed by a system.....	162
Table 51: System elements that should be consumed by a participant.....	163
Table 52: CIM elements that must be consumed by a system.....	164
Table 53: CIM elements that must be consumed by a participant.....	165
Table 54: System elements that must consume from other systems.....	166
Table 55: Participant systems' elements that must consume from other systems.....	166
Table 56: Factors .....	167
Table 57: Factor weight.....	168
Table 58: CIM element relevance.....	168
Table 59: CIM element weighed relevance .....	169
Table 60: Systems' elements implementing CIM elements.....	170
Table 61: System containing a system element.....	170
Table 62: Systems elements that will consume a specific system element .....	171
Table 63: Mapped systems elements that will consume a specific system element .....	171
Table 64: Participant which owns a specific system element.....	172
Table 65: Systems consuming a specific system element.....	172
Table 66: Participants consuming a specific system element.....	173
Table 67: System elements available in a system.....	174
Table 68: System elements required by a system.....	175
Table 69: System elements mapped for provisioning by a system.....	176
Table 70: System elements mapped for consumption by a system.....	177
Table 71: System elements that could be provided by a system.....	178
Table 72: System elements that should be provided by a system.....	179

Table 73: System elements that must be provided by a system.....	180
Table 74: System elements that could consume from other systems.....	181
Table 75: System elements that should consume from other systems.....	182
Table 76: System elements that must consume from other systems.....	183
Table 77: Relevance of a system based on the information available .....	184
Table 78: Relevance of a system based on the information required .....	185
Table 79: Relevance of a system based on the information mapped for provisioning .....	186
Table 80: Relevance of a system based on the information mapped for consumption.....	187
Table 81: Potential relevance of a system as a provider of information.....	188
Table 82: Actual relevance of a system as a provider of information .....	189
Table 83: Potential relevance of a system as a consumer of information.....	189
Table 84: Actual relevance of a system as a consumer of information .....	190
Table 85: Value and meaning of the information relevance scores .....	196
Table 86: Weights assigned to each risk.....	202
Table 87: Example of the results of the calculations performed by the software application .....	203
Table 4: Participants .....	274
Table 5: Elements of the Common Information Model.....	274
Table 6: Systems of a participant.....	275
Table 7: All systems .....	275
Table 8: Transformation services of a participant .....	276
Table 9: All transformation services.....	276
Table 10: Transformation of a system element into a CIM element.....	276
Table 11: Transformation of a CIM element into a system element.....	277
Table 12: Functions of a transformation service .....	277
Table 13: CIM elements available in a system.....	278
Table 14: CIM elements available in a participant.....	278
Table 15: CIM elements in all systems.....	278
Table 16: System elements available in a system.....	279
Table 17: Participant systems' elements.....	279
Table 18: CIM elements required by a participant .....	280
Table 19: CIM elements needed by all participants .....	280
Table 20: CIM elements required by a participant .....	281
Table 21: CIM elements required by a system .....	281
Table 22: System elements required by a system.....	282
Table 23: System elements required.....	282
Table 24: CIM elements mapped for provisioning by a participant .....	283
Table 25: CIM elements mapped for provisioning by a system.....	283

Table 26: System elements mapped for provisioning.....	284
Table 27: System elements mapped for provisioning by a participant.....	284
Table 28: CIM elements mapped for consumption by a participant.....	285
Table 29: CIM elements mapped for consumption by a system.....	285
Table 30: System elements mapped for consumption .....	286
Table 31: System elements mapped for consumption by a participant.....	286
Table 32: CIM elements that could be provided by a system.....	287
Table 33: CIM elements that could be provided by a participant.....	287
Table 34: System elements that could provide information to other systems .....	288
Table 35: Participant systems' elements that could provide information to other systems .....	288
Table 36: CIM elements that should be provided by a system.....	289
Table 37: System elements that should be provided by a participant.....	289
Table 38: System elements that should be provided.....	290
Table 39: System elements that should be provided by a participant.....	290
Table 40: CIM elements that must be provided by a system.....	291
Table 41: CIM elements that must be provided by a participant.....	291
Table 42: System elements that must be provided by a system.....	292
Table 43: System elements that must be provided by a participant.....	292
Table 44: CIM elements that could be consumed by a system.....	293
Table 45: CIM elements that could be consumed by a participant.....	293
Table 46: System elements that could consume from other systems.....	294
Table 47: Participant systems' elements that could consume from other systems .....	294
Table 48: CIM elements that should be consumed by a system .....	295
Table 49: CIM elements that should be consumed by a participant .....	295
Table 50: System elements that should be consumed by a system.....	296
Table 51: System elements that should be consumed by a participant.....	296
Table 52: CIM elements that must be consumed by a system.....	297
Table 53: CIM elements that must be consumed by a participant .....	297
Table 54: System elements that must consume from other systems.....	298
Table 55: Participant systems' elements that must consume from other systems.....	298
Table 56: Factors .....	299
Table 57: Factor weight .....	299
Table 58: CIM element relevance.....	299
Table 59: CIM element weighed relevance .....	300
Table 60: Systems' elements implementing CIM elements.....	301
Table 61: System containing a system element .....	301
Table 62: Systems elements that will consume a specific system element .....	301

Table 63: Mapped systems elements that will consume a specific system element.....	302
Table 64: Participant which owns a specific system element.....	302
Table 65: Systems consuming a specific system element .....	303
Table 66: Participants consuming a specific system element.....	303
Table 67: System elements available in a system.....	306
Table 68: System elements required by a system.....	307
Table 69: System elements mapped for provisioning by a system.....	308
Table 70: System elements mapped for consumption by a system .....	309
Table 71: System elements that could be provided by a system .....	310
Table 72: System elements that should be provided by a system.....	311
Table 73: System elements that must be provided by a system.....	312
Table 74: System elements that could consume from other systems.....	313
Table 75: System elements that should consume from other systems.....	314
Table 76: System elements that must consume from other systems.....	315
Table 77: Relevance of a system based on the information available .....	316
Table 78: Relevance of a system based on the information required .....	317
Table 79: Relevance of a system based on the information mapped for provisioning .....	318
Table 80: Relevance of a system based on the information mapped for consumption.....	319
Table 81: Potential relevance of a system as a provider of information.....	320
Table 82: Actual relevance of a system as a provider of information .....	321
Table 83: Potential relevance of a system as a consumer of information.....	322
Table 84: Actual relevance of a system as a consumer of information .....	323
Table 88: Scenario parameters and additional calculations.....	324
Table 89: Scenario concepts and indicators.....	325
Table 90: Scenario original data.....	338
Table 91: Scenario calculated data .....	339

(page intentionally left in blank)



## Acronyms and abbreviations

**ADL** Archetype Definition Language

**AFIS** Anti-Fraud Information Systems

**AHP** Analytic Hierarchy Process

**API** Application Programming Interfaces

**ARM** Architectural Reference Model

**C2** Command and Control

**C4ISR** Command, Control, Communications, Computers, Intelligence, Surveillance and Reconnaissance

**CACIS** Customs Advanced Cargo Information System

**CAD** Computer Assisted Design

**CapEx** Capital Investment Expenditure

**CASE** Computer Assisted Software Engineering

**CDFO** Common Design Features Ontology

**CDSS** Clinical Decision Support Systems

**CIM** Common Information Model

**CISE** Common Information Sharing Environment

**CISE** Common Information Sharing Environment

**CPT** Composite Positional Tolerance

**CREON** Coral Reef Ecological Observatory Network

<b>CSDP</b>	Common Security and Defence Policy
<b>DC</b>	Dublin Core
<b>DHS</b>	Department of Homeland Security
<b>DM</b>	Data Models
<b>DNA</b>	Deoxyribonucleic Acid
<b>DSR</b>	Design Science Research
<b>DUL</b>	DOLCE-UltraLite ontology
<b>EC</b>	European Commission
<b>ECRIS</b>	European Criminal Records Information Systems
<b>EIF</b>	European Interoperability Framework
<b>EIS</b>	European Interoperability Strategy
<b>EML</b>	Ecological Metadata Language
<b>EPRIS</b>	European Police Record Index Systems
<b>ESCO</b>	European Skills, Competences, Qualifications, and Occupations
<b>ETSI</b>	European Telecommunications Standards Institute
<b>EU</b>	European Union
<b>EUMSS</b>	European Union Maritime Security Strategy
<b>FBI</b>	Federal Bureau of Investigation
<b>FCC</b>	Future Combat Capability

<b>FICAM</b>	Federal Identity Credential and Access Management
<b>GCIS</b>	Global Change Information System
<b>GDP</b>	Gross Domestic Product
<b>GDPR</b>	General Data Protection Regulation
<b>GIoTS</b>	Global Internet of Things Services
<b>GoG</b>	Gulf of Guinea
<b>HER</b>	Electronic Health Record
<b>HIS</b>	Hydrologic Information System
<b>HL7</b>	Health Level Seven
<b>ICT</b>	Information and Communication Technologies
<b>ICZM</b>	Integrated Coastal Zone Management
<b>IHE</b>	Integrating the Healthcare Enterprise
<b>IIS</b>	Interagency Information Sharing
<b>IM</b>	Information Model
<b>IMP</b>	Integrated Maritime Policy
<b>IoT</b>	Internet of Things
<b>ISE</b>	Information Sharing Environment
<b>ISIS</b>	Islamic State of Iraq and Syria
<b>IT</b>	Information Technology

**ITACG** Interagency Threat Assessment and Coordination Group

**IUU** Illegal, Unregulated and Unreported

**JC3IEDM** Joint C3 Information Exchange Data Model

**KB** Knowledge Bases

**M2M** Machine-to-Machine

**MCDM** Multi-Criteria Decision Methods

**MDD** Multilevel Model-Driven

**MIP** NATO Multilateral Interoperability Programme

**MoU** Memorandum of Understanding

**MSP** Maritime Spatial Planning

**NATO** North Atlantic Treaty Organization

**NCTC** National Counterterrorism Center

**NER** Named Entity Recognition

**NIEM** National Information Exchange Model

**NOC** National Occupations Classifications

**NSI** Nationwide Suspicious Activity Reporting (SAR) Initiative

**NSISS** National Strategy for Information Sharing and Safeguarding

**OECD** Organization for Economic Co-operation and Development

**OMA** Open Mobile Alliance

<b>OpEx</b>	Operating Expenditure
<b>OR</b>	Operating Room
<b>OSSIE</b>	Open Surgical Semantic Interoperability Engine
<b>OWL</b>	Ontology Web Language
<b>RBM</b>	Results-Based Management
<b>RDF</b>	Resource Description Framework
<b>RDFS</b>	Resource Description Framework Schema
<b>RIM</b>	Reference Information Model
<b>SAR</b>	Suspicious Activity Reporting
<b>SBO</b>	Semantic Bridge Ontology
<b>SDO</b>	Standard Development Organization
<b>SEMED</b>	Semantic Ontology Mapping for Electronic Health Record Data
<b>SGS</b>	Semantic Gateway as Service
<b>SI</b>	Semantic Interoperability
<b>SIENA</b>	Secure Information Exchange Network
<b>SILF</b>	Semantic Interoperability Logical Framework
<b>SIS</b>	Schengen Information System
<b>SLTD</b>	Stolen and Lost Travel Documents
<b>SOA</b>	Service-Oriented Architecture

<b>SODA</b>	Structural Alignment Ontology OWL-DL
<b>SOnet</b>	Semantic Observations Network
<b>SoSI</b>	Systems of Systems Interoperability
<b>SQL</b>	Standard Query Language
<b>SSOA</b>	Semantic Service Oriented Architecture
<b>SWS</b>	Semantic Web Services
<b>TCO</b>	Total Cost of Ownership
<b>TSC</b>	Terrorist Screening Center
<b>UML</b>	Unified Modelling Language
<b>UNSC</b>	United Nations Security Council
<b>US</b>	United States
<b>USA PATRIOT</b>	Uniting and Strengthening America by Providing Appropriate Tools Required to Intercept and Obstruct Terrorism
<b>WMD</b>	Weapons of Mass Destruction
<b>WPM</b>	Weighted Product Model
<b>WSM</b>	Weighted Sum Model
<b>XML</b>	Extensible Markup Language

## Introduction

Information is essential for decision making; even for deciding which information is essential. The value of responsible information sharing is measured, ultimately, by its contribution to proactive decision making (The White House, 2012). Although being true that we rarely hold all the necessary information to make decisions, hence use the best information available, it is also true that we tend to strive, until the limit, for more information upon the conviction it may help us in making better decisions, even if, in some cases, it turns to be quite the opposite.

However, the reality is that we cannot tell how much information is enough. We can only say, based on our knowledge – which, by the way, also depends on the information made available to us so far - if a certain piece of information is relevant or not, once we hold it. Thereby, often, we do not know exactly which information is necessary.

Consequently, our access to information cannot be limited by our ability to specify which information is needed. By itself, this represents a revolution to one of the most consolidated principles of information sharing so far - the “need to know”, which has been pointed out, for exactly these same reasons, as one of the root causes of the 9/11 events, hence it is slowly giving room to its substitute – the “responsibility to share”.

Interagency Information Sharing (IIS) is the exchange of information among governmental agencies through computer systems. The term was coined in 1996 (Dawes, 1996) and other related terms can be found in the literature such as Government-to-Government Information Sharing (Akbulut et al., 2009), Cross-Boundary Information Sharing (Landsbergen Jr. & Wolken Jr., 2005) and Inter-organizational Information Integration (Schooley & Horan, 2007).

Information exchange is often used as a synonym of information sharing, which is not necessarily a good thing. From experience, the word exchange is often used, in information sharing initiatives, in a mercantile sense, that is, some organization is willing to provide information to another, if the latter is also available to provide back some other information of value.

However, this is completely against the (responsibility to share) principle whereby information must be provided to other organizations, simply because its owner decides it may be useful to them. Moreover, it will hardly favor organizations with little or close to no information in improving their situation. On the contrary, it will mostly foster the development of organizations which already hold plenty of information. Therefore, whenever possible, we prefer using the term information sharing.

The benefits of IIS can be many, such as e-Governance development (Australian National Audit Office, 1999; Baum & Di Maio, 2000; OECD, 2003; Ronaghan, 2002; Schooley & Horan, 2007) and better public services (Calo et al., 2012; Siau & Long, 2005a), and at different levels (i.e. political,

organizational and technical) (Dawes, 1996), thus contributing to improve the overall government image (Calo et al., 2012; Dawes, 1996), less fraud and crime (Jing & Pengzhu, 2009), more safety (Baseline, 2006; Bellamy, 2000; Dahlan et al., 2013; Gil-Garcia et al., 2005; Kean & Hamilton, 2004), security (Baseline, 2006; Calo et al., 2012; Kean & Hamilton, 2004; The White House, 2012), cybersecurity (Creasey, 2013), economic development and quality of life (Calo et al., 2012; L. Gordon et al., 2002).

While some of these benefits result from increasing the effectiveness of the agencies, other result from increasing their efficiency. In the first case, by providing information to the agencies that they did not have before, they become aware of new elements that, alone or combined with other information, allow them to make decisions and take actions that were not possible before. Then, in the second case, the efficiency of the agency can be improved in two main ways. Firstly, because by obtaining relevant information from other agencies is often more cost-effective than duplicating the capabilities of another agency. Secondly, but not least important, because additional information, again by itself or combined with other information, can be used to generate knowledge on how the present business processes can be improved.

The definitions of data, information and knowledge, although being at the heart of Information Science, are not necessarily consensual (Zins, 2007) and, particularly, data and information are often used interchangeably, which can lead to misunderstandings and wrong decisions. Therefore, throughout this document we shall consider that data are unstructured facts and figures (Thierauf, 1999) and that information is data with relevance and purpose (Bali et al., 2009). For data to become information, it must be contextualized, categorized, calculated and condensed (Davenport & Prusak, 2000). As knowledge, we shall consider that it is a fluid mix of framed experience, values, contextual information, expert insight, and grounded intuition that provides an environment and framework for evaluating and incorporating new experiences and information (Gamble & Blackwell, 2001). The relationships between these concepts is well depicted in the following figure.

The main objective of IIS is to provide relevant information to governmental agencies in a cost-effective way. Organizations are constantly looking for ways to improve their efficiency and effectiveness, and one of those ways is to obtain information that can add value to their activities. In this process, governmental agencies typically develop technological capabilities to acquire, store and process that information, which implies meaningful capital and operating expenses. However, if the information that is required by one agency is already available in other agencies, the most cost-effective way for this agency to obtain it is, often, to develop the means to get it from the systems of those organizations, rather than going through the process they have already gone, and thus incur into duplicated costs and unnecessary delays.



**Figure 1:** Data, information, knowledge and wisdom

Source: ritholtz.com

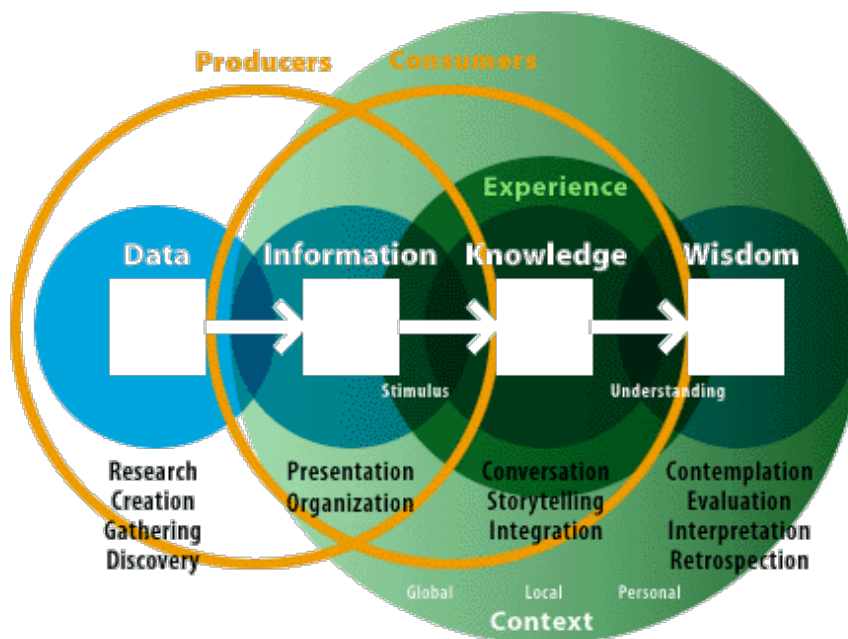

Interagency information sharing is not confined to a specific sector or country. In fact, it often has a cross-border and cross-sectorial nature, depending on the domain considered. For example, in the maritime domain, there are plenty of sectors involved, such as security, border control, defense, environment, customs and fisheries, which presently collect and require information that is relevant for other sectors as well. Likewise, neighboring countries have areas of common interest (e.g. borders) where, consequently, their agencies also collect and require information that is relevant for the other

countries. Therefore, nowadays there are numerous examples of cooperation among countries and agencies, from the same or different countries, where one of the key aspects is the exchange of information.

To exchange information, governmental agencies usually follow a series of steps. In a first moment, they identify which information is required and which systems already contain that information. Then, in a second moment, they identify a technological approach to exchange that information and the legal framework to support it. Finally, they define initiatives (i.e. projects and programs) to implement the legal, organizational and technological changes that were found necessary.

Regarding the technological approach, there are two important alternatives. One, more frequent, where organizations define an information model to exchange information on an ad-hoc and usually per-project basis; and another, where organizations agree on a comprehensive information model to exchange the information in that and in future initiatives, involving the same or other organizations. While the first approach is better in the short term, because it is faster and simpler, the second is better in the long-term, because it promotes reuse and maintainability. It goes without saying that the optimal approach would be one that could simultaneously promote the quick delivery of relevant solutions that could be easily reused and maintained.

Obtaining the benefits of information sharing requires change, and to make it happen, it is important to understand the forces for and against it. Inspired by the Kurt Lewin's "Force Field Analysis" technique (McMillan, 2008), we depicted those forces in the following figure, organized according to the most relevant boards where information sharing is played: the political, the operational (organizational), the legal and the technological.

From the political point of view, information sharing is very important to avoid or mitigate social, environmental and economic risks. For example, one of the most critical social risks presently facing Europe is that of irregular migration (European Commission, 2015b). In this case, information sharing among all authorities involved is crucial to mitigate it. By sharing information on the migrants' whereabouts and details, and on the human trafficking and smugglers organizations, public authorities involved will be able to understand better the situation and to act reactively and pro-actively. A similar example is that regarding the threat of terrorist attacks on the homeland and United States (US) interests abroad (The White House, 2012).

Security risks are inversely proportional to interagency information sharing (The White House, 2012). Risk to national security increases when the approach to information sharing is inconsistent, fragmented, or managed from a single-agency perspective. Risk decreases, however, with sound policies and standards, increased awareness and comprehensive training, effective governance, and enhanced accountability.

Still, from the political point of view, the objective of achieving higher levels of efficiency is also usually present; hence, lowering costs is usually a priority and information sharing has the potential for it. Mission objectives must be met with innovation and agility in an extremely austere budget environment (The White House, 2012).

Information sharing is normally the more economically advantageous way to obtain information. The other is for an organization to develop its own capabilities to acquire, store and process information, which means investing in the development of sensors, platforms and systems. When an organization tries to obtain information from other organizations, which already hold the information of interest, they eventually have to develop the necessary capabilities for it, since organizations have differences in the technologies used (The White House, 2012).

**Figure 2:** Information sharing driving and restraining forces

Source: Author

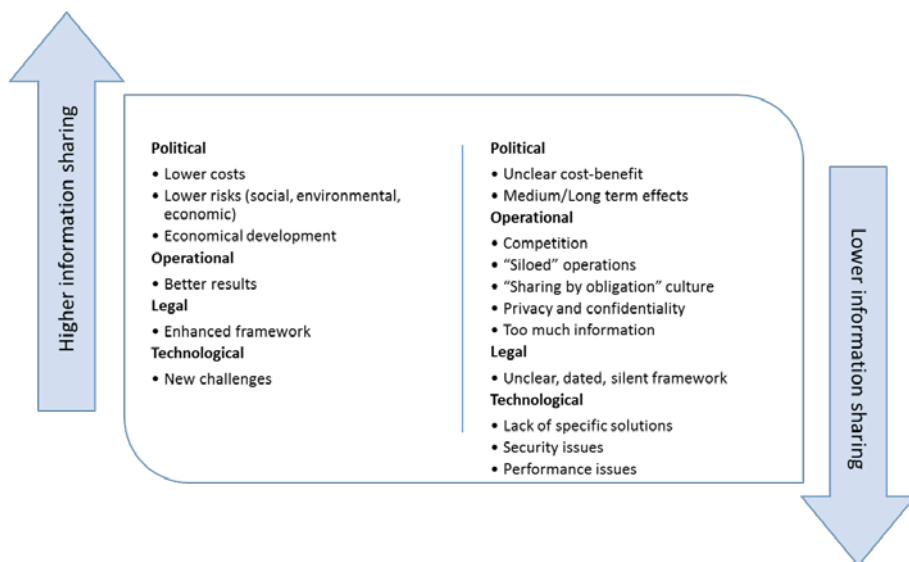

On the one hand, the development of capabilities for exchanging information is generally much less expensive, both from the investment and operations perspectives, than the development of sensors, platforms and systems for acquiring, storing and processing it. On the other hand, if public services are the organizations under consideration, then the option of not sharing information and developing own capabilities, when the information is already available at some other service, is a double mistake, because taxpayers are financing the acquisition, storage and processing of the same information, by the state, more than necessary.

However, we should not confuse this waste of resources with redundancy or accuracy. Sometimes, to ensure the availability of information, for example regarding a certain geographical area of interest, it is

necessary to invest in the duplication of capabilities, which can possibly be ensured by different organizations in collaboration. A different scenario of necessary duplication is when the accuracy of information is required, and this leads us to invest in redundant capabilities to ensure it; for example, to help overcoming limitations in the systems involved.

Last, but not least, costs can also be decreased because organizations use their resources in a complementary manner to achieve common objectives. However, for this complementarity to occur, information sharing is essential, without which it will not be possible to identify those opportunities and act in a coordinated way. For example, in a maritime search and rescue operation, knowing beforehand that an adequate asset for the operation, from a partner organization, is in the area and can be used for that purpose, will prevent deploying unnecessary assets for the same purpose.

The relationship between information sharing costs and benefits is still unclear. Although, at the political level, there is a good perception of the benefits of information sharing, it is not accurate, neither of the costs they imply. One of the reasons for this, is that there are plenty of possibilities for sharing information and, sometimes, if not done properly, it may carry unwanted results. Another reason is related with the difficulty of organizations to quantify some benefits; for example, the difficulty of quantifying the benefit of preventing a maritime pollution incident. Adding to this, is the fact that investments in information sharing usually do not produce effects in the short term, hence are not so attractive from the political point of view. Finally, another important aspect that usually hinders information sharing, from the political point of view, is the existence of different policies, unaligned, for this matter, which prevent unauthorized users from gaining access to the necessary information (The White House, 2012).

The last aspect in favor of information sharing, from the political point of view, is that information sharing creates opportunities for innovative products and services, hence jobs and economic development (European Commission, 2010e; Meiner, 2010). For example, information sharing will require the integration of the existing operational information systems, their adaptation to deal with more and new information and better support to the end users, now that much more information available can hamper their decision making capability.

From the operational point of view, organizations are essentially willing to obtain better results and they realize that information sharing can assist in it. However, practice shows that usually organizations compete with each other; therefore, although receiving information is thought of as an advantage, providing it may mean conceding advantages to their competitors, which is not so interesting. This is why it is not uncommon to see, in information sharing initiatives, organizations asked which information they want and which they are willing to share, replying that they want to receive everything and provide very little to nothing.

Usually organizations operate in “silos” and they only interact when they really need to. Most frequently

this happens to prevent major risks from happening. If organizations do not work with each other in a regular and systematic way, then the need for information sharing is not imperative and will hardly happen. As well noted in the NSISS (The White House, 2012), organizations need to recognize their statutory responsibilities for sharing and safeguarding information, overcome historically insular practices and policies, embrace a government-wide perspective, and agree to participate in structured collaboration. The European Union is in line with this view by considering that all partners from civilian and military authorities and actors need to cooperate better, respecting each other's organizations (Council of the European Union, 2014).

Unfortunately, the prevailing culture is that of "sharing by obligation", which means that organizations usually share information with each other only when compelled to (Information Sharing Environment Program Manager, 2006). Without willing to risk sharing some information with their competitors and without real situations where sharing is the only option, such as joint operations, organizations often avoid sharing information with each other, unless obliged to do so, and even in these cases, the legal framework is frequently used as a barrier to sharing information.

Promoting a culture of information sharing is therefore the first major challenge identified in the Information Sharing Environment (ISE) implementation plan (Information Sharing Environment Program Manager, 2006). But, for example in the case of the US Homeland Security, the success of implementing such a culture will depend heavily on the establishment and maintenance of clear policy, authority, and guidance for the sharing of terrorism information and widespread application of training and incentives to share.

Although some studies (European Commission, 2014b; Finnish Border Guard, 2014; Secrétariat Général de la Mer, 2012) show that most of the information required can be shared among governmental agencies, without further legal considerations, they also show that a smaller part of that information, which is usually related with personal data or commercial or governmental secrecy, demands extra care and procedures. This idea is further corroborated by the NSISS (The White House, 2012) and is reinforced by the recently approved General Data Protection Regulation (GDPR) in the European Union (European Parliament & Council of the European Union, 2016). However, often the lack of knowledge regarding what these procedures and regulations imply or to which information they apply, and under which circumstances, is also a limitation for information sharing.

Presently, the legal framework relevant for information sharing is often, in several domains, unclear, dated, and omissive. For example, there are cases where the legislation foresees that information from certain systems can be accessed by a specific set of authorities; however, because some of these authorities do not exist anymore, and other organizations that replaced them and need to access that information are not foreseen in those diplomas, they cannot access it, which hampers their operational activities.

Moreover, during operational activities, legal experts are frequently faced with requests regarding the feasibility of accessing or sharing some information which, with such a legal framework, highly difficulties their action and implies predictable consequences at the operational level. Therefore, the legal experts' will of having an enhanced legal framework is a force in favor of information sharing.

But information sharing can be detrimental as well. If we increase significantly the information available without properly adjusting the capability to process it, most likely our ability to decide will be affected negatively, thus hampering operational performance. If the information is so much that we are not able to properly process it, then we are unable to separate what is essential from what is irrelevant or accessory, and so our decision making can be hampered.

Information sharing should occur, preferably, via the integration of information systems. Information can be shared via two different ways. Via the traditional communications means (i.e. telephone, fax, letter), or via the integration of information systems. The latter means that if two organizations have information systems, they decide to integrate them, in a way that information is sent from one system to the other, electronically and seamlessly.

When information is received via traditional communications means, the processing of that information is usually made by its end user. When the information is received by an information system, on the other hand, it becomes possible for end users to take advantage of the enormous potential information technologies presently have to process it for them. The advantages of this possibility are innumerable; less processing errors, faster processing, higher ability to deal with information simultaneously, higher ability to integrate the information received with other existing information and generate new information and knowledge, to name eventually the most important ones.

Naturally, when no technological solutions exist for sharing information, via the integration of information systems, then organizations have to resort to the traditional way, which hampers not only information sharing but also its potential resulting from its processing with information technologies as abovementioned.

On the other hand, information sharing solutions based on the integration of information systems entail several technological challenges, related for example with security, performance or availability. These challenges represent opportunities for the creation and maintenance of innovative products and services which can contribute to create new jobs and economic development. For this reason, information sharing is important from the technological point of view.

Moreover, information sharing means that information will be available in many more places than it used to be. Although this is one of the objectives, it comes with a price when such information is sensitive – more possibilities exist for those willing to access without having the necessary permissions. Hence,

information sharing may originate security vulnerabilities that must be well considered and dealt with. The ability to protect information as it is shared is directly related to the maturity of governance processes, access controls, identity management, enterprise audit capabilities and network interoperability efforts (The White House, 2012).

Furthermore, information shared is often incomplete, inaccurate and contradictory, therefore decisions cannot be made without ensuring first the quality of the information received, which requires adequate tools and techniques, such as information correlation with advanced analytics (The White House, 2012).

In a nutshell, information sharing is a very promising practice, capable of producing very different and relevant impacts in our society and therefore key to achieve political goals worldwide. Nonetheless, and although the challenges that its generalized adoption entails are many, it is slowly becoming adopted.

Interoperation and interoperability are distinct but interconnected concepts. While interoperation refers to the actual processes of exchanges between information systems, interoperability is their capacity to interoperate at any given time (Hans Jochen Scholl et al., 2012). Therefore, IIS requires the interoperability of the government agencies involved (Landsbergen Jr. & Wolken Jr., 2005). Europe is highly committed in developing the interoperability among its public services (European Commission, 2010a) and, for this purpose, it has developed the European Interoperability Framework (EIF) (European Commission, 2004), comprising four different interoperability layers (i.e. Legal, Organizational, Semantic and Technical).

**Figure 3:** The EIF four layers of interoperability



Source: (European Commission, 2010d)

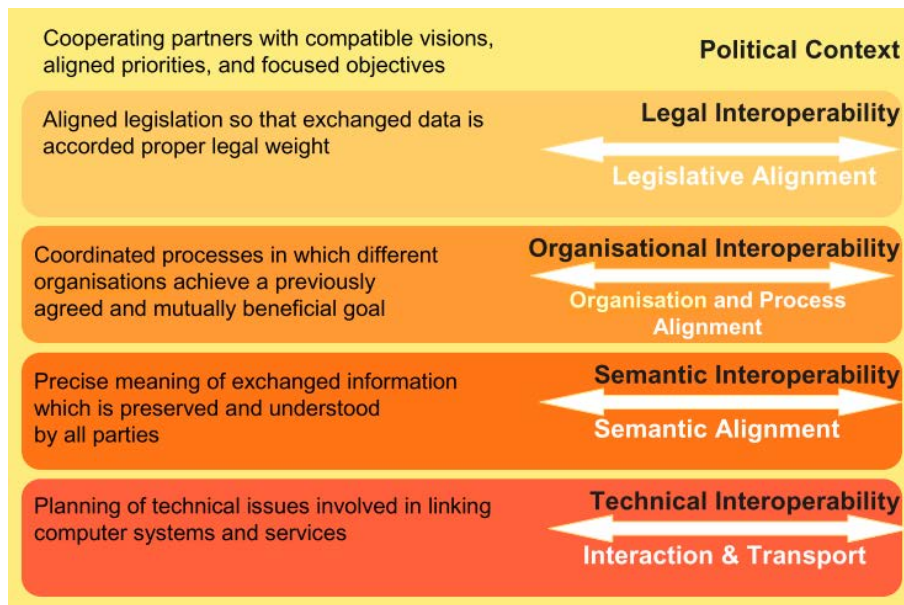

Semantic Interoperability (SI), which term was first coined in 1995 (Heiler, 1995), is one of those layers and is particularly important, since it has the purpose of ensuring that providers and consumers have a common understanding of the meaning of the exchanged information. Presently, in the context of eHealth (ISO13606 community, 2008) for example, SI is defined as the ability to automatically interpret the information exchanged, meaningfully and accurately, in order to produce useful results as defined by the end users of both systems. In this context, both sides must defer to a common information exchange reference model, to achieve semantic interoperability, and the content of the information exchange requests are unambiguously defined; that is, what is sent is the same as what is understood.

Presently, the development of information exchange, and consequently of interoperability, among

governmental agencies is a priority for many countries worldwide, especially when it comes to addressing contemporary societal challenges such as terrorism, organized crime and migration (Council of the European Union, 2014; European Commission, 2015b, 2015c; EUROPOL, 2017; The White House, 2012). But there are many other areas, where peoples' lives are not threatened, which also require a high degree of collaboration among the authorities involved, and thus where IIS is also essential. Some of these areas are taxes (Jing & Pengzhu, 2009), health (Calo et al., 2012), smart cities (Batty et al., 2012) and industry 4.0 (Lasi, H., Fettke, P., Kemper, 2014).

Several years after the 9/11, terrorist attacks on the US, the terrorist threat remains. The US national security depends on the ability to share the right information with the right people at the right time, and although all partners in the terrorism related Information Sharing Environment (ISE) are committed to sharing counterterrorism information, there are still various areas in which improvements could enhance information sharing (OIG, 2017).

The European Union (EU) must also improve information-sharing internally and with the United States (US) and Turkey to fight against terrorism (Baczynska et al., 2016; Shalal, 2016). For this purpose, and after the recent terrorist attacks in Belgium and France, the EU devised a roadmap to enhance information exchange among police and border guards (Rankin, 2016).

The recent upsurge in Islamic State of Iraq and Syria (ISIS) related activity in the Southern Philippines has heightened concerns that the region could become a de facto province of the ISIS and while security agencies in the Philippines, Indonesia, Malaysia, and Singapore are already engaged in regular information sharing, it is clear from the persistence of this problem that this is not enough (Liow, 2016).

Argentina signed recently a tax information exchange agreement with the US, which is expected to help the government identify undeclared assets in the US as well as combat money laundering and the potential financing of terrorism (Bronstein, 2016). Meanwhile, during the preparation for the 2016 Olympic Games, Brazil witnessed a rise in the threat of attacks by Islamic terrorists, and information sharing with foreign security forces was one of the measures adopted to avert a potential attack (Eisenhammer & Brown Tom, 2016).

Finally, in regards to piracy and armed robbery at sea in the Gulf of Guinea (GoG), the United Nations Security Council (UNSC) has recently urged states and international organizations to share information and to prevent the revenues generated by such acts from contributing to the financing of terrorism (United Nations Security Council, 2016). For the same reasons, this could also be extended to Somalia where, after over three years since the last large commercial vessel was hijacked, pirates seem to have resumed their activity (Hourel, 2017), as anticipated (UNSC, 2016).

Having in mind that enhancing IIS, and consequently interoperability, is usually a complex endeavor

taking place in a rapid changing environment, we need to use performance-driven and agile management approaches to succeed. While performance-driven approaches will ensure that the strategic goals are achieved, agile management approaches will help in overcoming the typical problems governmental agencies typically face when developing Information Technology (IT) projects.

Developing interoperability in a properly managed way demands the capability to rightly define the present state, the objectives, as well as the possible actions to achieve them. The definition of the present state implies identifying all areas where interoperability already exists, and those which lack it. The objectives must be specific, measurable, attainable and realistic, which depends, among other, on understanding the context possibilities and limitations. Finally, the prioritization of the different ways to achieve the objectives defined depends on the ability to understand the relative importance of each possible action. Without such a capability, interoperability developments may lead to unnecessary costs, ineffective actions, general demotivation and projects failure, ultimately contributing to information not being shared, hence to higher costs and risks, especially worrying if in domains with high societal impact.

Performance management is the process of managing and assessing an organization's progress toward its strategic goals. When successfully used, the process and the resulting information provide a foundation for guiding budget and resource allocation decisions; focusing employee endeavors as well as incentive and training programs; proposing organizational restructuring as appropriate; and recognizing program gaps and areas for further development (Information Sharing Environment Program Manager, 2006). In its National Strategy for Information Sharing and Safeguarding (NSISS) (The White House, 2012), the US consider essential a management approach entailing an holistic view of the departments and agencies progress towards achieving information sharing goals, including not only the measurement of improvements in information sharing, but also of their overall effectiveness (e.g. how the shared information helps to achieve the mission). The assumption is that performance management and metrics, when paired with effective leadership, reinforces progress and motivates personnel to meet high expectations and professional standards and helps foster a culture that values information sharing.

Traditionally, IT governmental projects follow a waterfall approach, which is known to hide problems until the end and to struggle with changing requirements, especially in large-scale and long-term delivery contracts (Mergel, 2016). Therefore, still too many of these projects fail. For example, 94% of IT projects in the US Federal Government are over budget and behind schedule, and 40% are never finished (Van Dyck, 2016). To overcome these challenges, agile approaches well-established in the private sector are being moved into government operations (Mergel, 2016).

The first of the twelve principles of the Agile Manifesto (Agile Alliance, 2001) states that "*the highest priority is to satisfy the customer through early and continuous delivery of valuable software*". In other words, agile projects have to be incremental and deliver the highest value first and, consequently, they

require prioritized lists of features (Rubin, 2012) where the business value - the expected benefit from features implementation, which can be other than a monetary value (Heidenberg et al., 2012) - is a key factor (Bakalova et al., 2011). Consequently, complex IIS initiatives, which follow agile approaches, must also be iterative and incremental, and the prioritization of the activities must be based on their business value.

**Figure 4:** The iterative and incremental development of semantic interoperability

**Source:** Authors

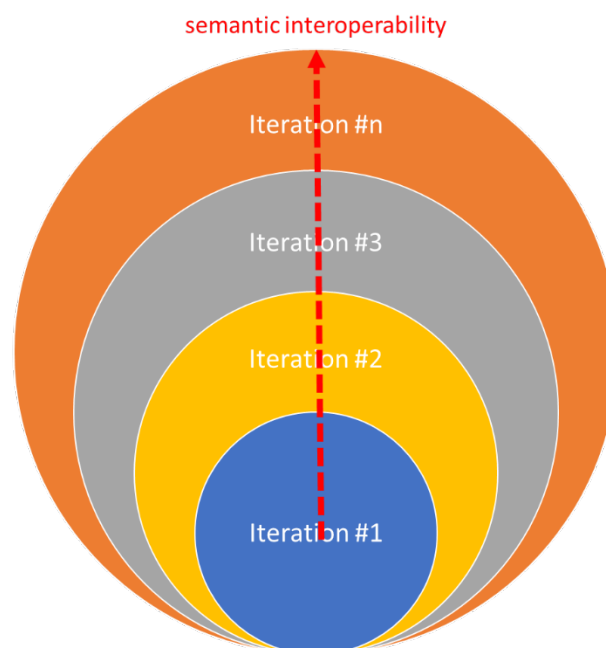

Typically, when a program or a project is proposed, it is necessary to explain which are its goals and main

outcomes, as well as how its activities and outputs will contribute to achieve them. Programs and projects are ways that organizations have to achieve their strategic objectives, and therefore those relationships must be as clear as possible. Based on this, a cost-benefit analysis is also usually performed, to help deciding if the project is worthwhile or not. In this context, having instruments that enable aligning and understanding the role and value of each of these aspects would largely benefit the proposal development process.

Sometimes there are diverse ways to achieve the same goals and outcomes. Consequently, different programs and projects may be proposed to achieve them, in which case a decision has to be made regarding which is the most cost-effective approach. This implies that the proposed alternatives have to be compared and while some will be selected, other will be discarded. To perform a fair comparison, the approach used must be the same. And so, having instruments that allow understanding the advantages and disadvantages of each alternative in a systematic and normalized way would largely benefit this kind of activities.

In this context, the main objective of this research is to advance the state of the art in the assessment of the semantic interoperability of organizations involved in specific information exchange initiatives, by developing instruments for this purpose, that also support the utilization of performance-driven and agile management approaches. This document is organized in three different parts. The first part presents the background in two different domains, the political and legal and the scientific. The second part presents the research methodology used and the last part presents and analyses the results achieved, which include the iShare framework components, its application in a real case and its evaluation.

## PART I – Background

*“Never before has the need for information sharing become more evident as it has in the past two years, with its unprecedented number of failed, foiled, but also completed jihadist terrorist attacks across Europe”*

(EUROPOL, 2017)

(page intentionally left in blank)

# 1 Political and legal

## 1.1 Strategies and policies

Information sharing among governmental agencies is increasingly being adopted, and the evidence of that is its role in various strategies and policies worldwide, particularly in the European Union (EU) and in the United States (US). As we will see throughout this chapter, while some of these strategic documents are specifically about information sharing, others consider information sharing as one of their main lines of action.

### 1.1.1 EU Integrated Maritime Policy

The EU Integrated Maritime Policy (European Commission, 2007), was probably the first document that motivated our work to enhance maritime surveillance information exchange across European governmental agencies. Motivated by the ocean's strain that is stemming from its increasing, but most needed, exploitation, which is causing conflicts of use and the deterioration of the marine environment, the European Commission (EC) developed the concept of Integrated Maritime Policy (IMP). This concept, that is based on the recognition that all matters related to the oceans are interlinked and so all related policies must be coherent and developed jointly, is expected to help Europe in facing the challenges of globalization and competitiveness, climate change, degradation of the marine environment, maritime safety and security and energy security and sustainability.

Within this strategic document, the EC establishes its commitment and the actions necessary to develop, among other, a governance framework and several tools for integrated policy-making. Particularly, these tools include a European Network for Maritime Surveillance, the Maritime Spatial Planning (MSP) and Integrated Coastal Zone Management (ICZM) and an infrastructure for natural and human activity data and information on the oceans.

The IMP states that maritime surveillance is essential to ensure the safe use of the sea and to secure Europe's maritime borders. For this reason, the EC considers that maritime surveillance activities and interoperability, among the organizations involved at the European level, must be optimized, since they are key factors to face the challenges and threats posed by safety of navigation, marine pollution, law enforcement and overall security. More specifically, more coordination must be achieved within and among Member States coastguards and other appropriate agencies. Consequently, the EC has committed to *“take steps towards a more interoperable surveillance system to bring together existing monitoring and tracking systems used for maritime safety and security, protection of the marine environment, fisheries control, control of external borders and other law enforcement activities”*.

### 1.1.2 EU Maritime Security Strategy

The purpose of the European Union Maritime Security Strategy (EUMSS) (Council of the European Union, 2014) is to secure the maritime security interests of the EU and its Member States against the risks



and threats in the global maritime domain. Moreover, it aims to contribute to a stable and secure global maritime domain, in line with the Member States, European and international legislation.

The EUMSS provides a framework that facilitates cross-sectoral cooperation within, between and across civilian and military authorities and actors and contributes to the full use of the growth potential in the maritime domain. It also aims to foster mutual support between Member States and to allow for joint security contingency planning, risk management, conflict prevention and crisis response and management.

Therefore, the EUMSS is based on several principles, that include a cross-sectoral approach and maritime multilateralism. Both these principles imply an elevated level of cooperation, and hence of information exchange, among Member States, European and third countries' agencies. In addition, some of the objectives of the EUMSS also imply the development of information exchange. For example, the objective to contribute to security at sea and help secure the Union's maritime borders, the objective to enhance the growth and jobs potential of the seas, the objective to promote coordination and development of synergies with and amongst Member States and, last, but not least, the objective to promote enhanced common situational awareness and better sharing of information, taking into account not only the need to know but also the need to share, thus anticipating threats by following a comprehensive approach.

Consequently, the EUMSS considers that access to timely and accurate information and intelligence is crucial for the establishment of a common maritime awareness picture, which in turn leads to better operations and a more efficient use of scarce resources. Moreover, the integration of different data sources in the maritime domain, on the basis of existing national and international law, is a key task, that results in a better understanding of what is happening at sea and, furthermore, the more information is aggregated and integrated, the more complete is the maritime picture created and more value is delivered to the operational end-users, in a cost-effective way.

Therefore, the objective is to ensure that maritime surveillance information collected by one maritime civilian or military authority, considered necessary for the operational activities of other authorities, can be shared and subject to multiuse, rather than collected and produced several times. Specifically, the aim is to arrive at a common validated maritime awareness picture and to contribute to a more coordinated use of available space systems and remote sensing technologies and their derived applications and services.

Consequently, the EUMSS prioritizes the improvement of cross-sectoral cooperation and interoperability at national and EU level, the strengthening of cross-border cooperation and information exchange, a consistent approach in supporting maritime surveillance in the EU and the global maritime domain and the development of the Common Information Sharing Environment (CISE).

### 1.1.3 EU Agenda on Migration

Another example of where information sharing plays a key role is in the European Agenda on Migration (European Commission, 2015b). Aiming to provide a solution to the unprecedented migration flows, mostly stemming from Africa through the Mediterranean and from Middle-East through Greece and the Eastern Balkans, that resulted into unacceptable massive losses of lives and violations of human rights, the European Commission has developed this strategic document including various actions, to be performed by the European Commission and by the Member States, divided between short, medium and long term.

In the short term, the priorities are to save lives at sea, to target criminal smuggling networks, to respond to high-volumes of arrivals within the EU through - relocation, to protect displaced persons in need – resettlement, to work in partnership with 3<sup>rd</sup> countries to tackle migration upstream and to use EU's tools (i.a. 'Hotspot' approach, emergency funding) to help frontline Member States. In all these actions the collaboration of the agencies, from the Member States and from the European Commission, is paramount, and information sharing among them is vital.

In the medium term, the actions foreseen are reducing the incentives for irregular migration, saving lives and securing external borders, to develop a strong common asylum policy and a new policy in migration. Likewise, all these actions imply a strong collaboration between the European Commission and Member States agencies involved. But, in this case, we would highlight three that are clear examples of where information sharing is paramount. The first one is the fight against smugglers and traffickers, the second one is the effort to save lives and secure the Mediterranean maritime borders, and the efforts to implement a coherent asylum system.

Finally, in the long term, the objectives are to complete the common European asylum system, to develop a shared management of the European border and to develop a new model of legal migration. Again we find here that all these actions will require a strong collaboration and thus streamlined information sharing among all the organizations involved, but in particular we highlight the challenge that is in developing the shared management of the European border. This action includes asset sharing, joint exercises and dual use of resources, where information sharing is paramount.

### 1.1.4 EU Agenda on Security

Yet another example of where information sharing plays a key role, at the European level, is the European Agenda on Security (European Commission, 2015c). To ensure that Europeans live in an area of freedom, security and justice, and to face the threats posed by radicalization, violence and terrorism, that are becoming ever more varied, international, cross-border and cross-sectorial, the European Commission developed this document which aims to drive better information exchange, increased operational cooperation and mutual trust, and that prioritizes terrorism, organized crime and cybercrime as interlinked areas where the EU action can make a real difference.

One of the objectives of this agenda is for the EU to work better together on security and, for this purpose, five key principles are defined. The first is to ensure the compliance of fundamental rights, the second is to increase transparency, accountability and democratic control, the third is to ensure better application and implementation of existing EU legal instruments, the fourth is to develop a more joined-up inter-agency and a cross-sectorial approach and the last is to bring together all internal and external dimensions of security. For successfully following these principles, interagency information sharing is certainly necessary, given their crosscutting nature. However, two of them where this is really evident are the fourth and the fifth. In the fourth, relevant EU agencies in Justice and Home Affairs are characterized as information hubs which cooperation needs to be deepened. And in the fifth, the need to reinforce the links between Justice and Home Affairs and the Common Security and Defense Policy (CSDP) is explicit.

Another objective of this agenda is to strengthen the pillars of the EU action, which implies that all actors involved, from the EU and the Member States, fully implement existing instruments, and where necessary the development of new or existing tools in fields including information exchange and operational cooperation. As such, the priorities set are to achieve better information exchange, to have an increased operational cooperation and training, funding and research and innovation actions. In this particular case, information exchange is a clear and explicit priority, and is focused primarily in some of the Union's noteworthy information systems in the field of border security, such as the Schengen Information System (SIS) that includes wanted or missing persons or objects and terrorist suspects, the Stolen and Lost Travel Documents (SLTD), the Customs Advanced Cargo Information System (CACIS), the Anti-Fraud Information System (AFIS), the Prum framework that includes DNA profiles, fingerprints and vehicle registration data, the Secure Information Exchange Network (SIENA), the European Criminal Records Information System (ECRIS), the European Police Record Index System (EPRIS) and the Maritime Common Information Sharing Environment (CISE).

### 1.1.5 EU eHealth Action Plan

Public health expenditure in the EU's 27 Member States was on average 5.9% of GDP in 1990, rose to 7.2% of GDP in 2010, and the projections show that expenditure may continue to grow to 8.5% of GDP in 2060 due to the ageing population and other socio-economic and cultural factors. In addition, the long-term care expenditure projection would on average almost double over the projection period. Concurrently, the working age contingent is expected to fall dramatically from 61% to 51% of the total population while the share of the elderly (65+) and very old (80+) population in the EU is projected to grow respectively from 17.4% in 2010 to 30.0% in 2060 and from 4.7% in 2010 to 12.1% in 2060 (European Commission, 2012).

eHealth is the use of ICT in health products, services and processes combined with organizational change in healthcare systems and new skills, to improve health of citizens, efficiency and productivity in healthcare delivery, and the economic and social value of health. eHealth covers the interaction between

patients and health-service providers, institution-to-institution transmission of data, or peer-to-peer communication between patients and/or health professionals (European Commission, 2012). Moreover, the interoperability of ICT-enabled solutions and of data exchange is the precondition for better coordination and integration across the entire chain of healthcare delivery and health data exchange, while unlocking the EU eHealth single market. (European Commission, 2012).

Therefore, eHealth was considered as one of six promising lead markets (European Commission, 2012). eHealth and wellbeing are areas with high growth potential and possibilities for innovation notably by unlocking effective health data exchange. eHealth can benefit citizens, patients, health and care professionals but also health organizations and public authorities. eHealth – when applied effectively - delivers more personalized ‘citizen-centric’ healthcare, which is more targeted, effective and efficient and helps reduce errors, as well as the length of hospitalization. It facilitates socio-economic inclusion and equality, quality of life and patient empowerment through greater transparency, access to services and information and the use of social media for health.

The eHealth Action Plan (European Commission, 2012) aims at addressing and removing the barriers to interoperability and the implementation of eHealth systems. It clarifies the policy domain and outlines the vision for eHealth in Europe, in line with the objectives of the Europe 2020 Strategy (European Commission, 2010b) and the Digital Agenda for Europe (European Commission, 2010a). It presents and consolidates actions to deliver the opportunities that eHealth can offer, describes the EU's role and encourages Member States and stakeholders to work together.

The most pressing health and health systems challenges of the first half of the 21<sup>st</sup> century (European Commission, 2012) are to 1) improve chronic disease and multi-morbidity (multiple concurrent disease) management and to strengthen effective prevention and health promotion practices; 2) increase sustainability and efficiency of health systems by unlocking innovation, enhancing patient/citizen-centric care and citizen empowerment and encouraging organizational changes; 3) foster cross-border healthcare, health security, solidarity, universality and equity and 4) to improve legal and market conditions for developing eHealth products and services.

Consequently, to tackle these challenges, the eHealth action plan (European Commission, 2012) established the following objectives: 1) to achieve wider interoperability of eHealth services; 2) to support research, development and innovation in eHealth and wellbeing to address the lack of availability of user-friendly tools and services; 3) to facilitate uptake and ensuring wider deployment and 4) to promote policy dialogue and international cooperation on eHealth at global level.

In this context, the European Commission recognized the need for an eHealth interoperability framework, building on eHealth roadmaps and the general European Interoperability Framework (EIF) (European Commission, 2012) with its four levels of interoperability: legal, organizational, semantic and technical.

Moreover, the eHealth Network set up by Directive 2011/24/EU (European Parliament & Council of Europe, 2011) is the main strategic and governance body at EU level to work towards interoperability of cross-border eHealth services (European Commission, 2012).

### 1.1.6 EU Interoperability Strategy

Presently, one of the European Commissions' priorities is to remove the barriers to a digital single market in Europe (European Commission, 2017b) and, hence, to improve interoperability among governmental agencies. The public sector plays a key role in the digital market, namely as a service provider, and there is still immense potential to improve its services through end-to-end integration. Therefore, public services should be linked and reach beyond national borders to interconnect with the similar services at EU level.

But the goal of enhancing the Union's interagency interoperability is not new. Although with a different motivation, the first initiative in this regard goes back to 1999 and entailed the implementation of a series of guidelines for the establishment of networks for the electronic information exchange, between Member States' administrations and between these and institutions and bodies of the European Community, to support the establishment of the Economic and Monetary Union, and to support the Community's decision-making processes.

Later, in 2010, after supporting several programmes to develop, promote and use interoperability solutions in the EU, the EC defined (European Commission, 2010f) the European Interoperability Strategy (EIS). This time, the main driver to develop interagency interoperability and information exchange was to maximize the social and economic potential of information and communication technologies, as defined in the Digital Agenda for Europe (European Commission, 2010a).

In fact, the role of interoperability was so relevant that it was considered that the Digital Agenda for Europe could only take off if interoperability based on standards and open platforms was ensured. Moreover, it was considered that delivering European public services to European citizens and businesses would be difficult, if not impossible, without interoperability among European public administrations. In this context, several challenges were identified in the legal, organizational, semantic and technical levels.

The European Interoperability Strategy for European public services (EIS) (European Commission, 2010d) set out a common and coherent approach to interoperability, developed jointly by the European Commission and the Member States. It entailed various activities in the fields of trusted information exchange, interoperability architecture and assessment of the ICT implications of new legislation.

### 1.1.7 US Strategy for Information Sharing and Safeguarding

In the United States (US), the National Strategy for Information Sharing and Safeguarding (NSISS) (The White House, 2012) places information sharing at the heart of the cooperation among intelligence,

military, diplomatic, homeland security, law enforcement, and public health communities, which is considered essential for ensuring the safety and security of the US and the American people.

Triggered by the 9/11 events, information sharing and cooperation among public services has improved significantly in the US. However, some episodes continued to exist where critical information was not shared quickly or widely enough, or when unauthorized disclosures of classified and sensitive information damaged the US National Security (The White House, 2012). Hence, the need for the NSISS, which aims to achieve a good balance between sharing information with those who need it to keep the country safe and safeguarding it from those who aim harm.

The principles on which information sharing and safeguarding in the US are grounded are the notions (The White House, 2012) that 1) information is a national asset and therefore public services have an obligation to make information available to national security missions and 2) the risk management is shared, thus contributing to build and sustain the trust required to exchange information and 3) better decision making is the purpose of sharing information.

In this context, the NSISS aims to achieve several goals. First to drive collective action through collaboration and accountability, namely by increasing the use of common processes and streamlining the development of information sharing agreements. Second to improve information discovery and access through common standards (for information sharing). Third to optimize mission effectiveness through shared services and interoperability (and increased efficiency in acquisition), namely by improving assured data, services and network interoperability. Fourth to strengthen information safeguarding through structural reform, policy and technical solutions. Fifth to protect privacy, civil rights, and civil liberties through consistency and compliance, namely by building protections into the development of information sharing operations.

## **1.2 Projects and programmes**

The strategies and policies abovementioned, related to security in the EU and in the US, originated two noteworthy, and conceptually similar, initiatives to implement the objectives therein stated, which are the EU Maritime Common Information Sharing Environment (CISE) and the US Information Sharing Environment (ISE). In addition, but more on a crosscutting level, the EU has also developed its Interoperability Strategy (EIS) for leveraging the potential of the digital single market.

### **1.2.1 EU Maritime Common Information Sharing Environment**

In 2010, following its Integrated Maritime Policy, the EU launched the CISE (European Commission, 2010e) initiative to address some of the various challenges faced by Member States' maritime authorities<sup>1</sup>.

---

<sup>1</sup> Those which missions are in the domains of maritime safety and security, search and rescue, accident and disaster response, fisheries control, marine pollution, customs, border control, law enforcement and defense.

These challenges include information being collected essentially for the purposes of the agency collecting it, surveillance systems developed on the basis of sector-specific national, international and EU legislation and threats requiring a trans-national and trans-sectoral approach. The CISE was estimated to bring a beneficial impact between 160 and 420 million euros per year, over the ten years following its implementation (European Commission, 2014b).

Therefore, the CISE was created to allow for increased exchange of information between maritime authorities, and hence to make maritime surveillance in the EU better and cheaper. So, to achieve this purpose, four main objectives were defined. First all relevant user communities should be interlinked. Second, a technical framework should be built for interoperability and future integration. Third, it should support information exchange between civilian and military authorities and, fourth, it would entail specific legal provisions.

Consequently, four steps were defined to accomplish these objectives. The first was the identification of all user communities involved in maritime surveillance. The second was the realization of a data gaps analysis to baseline the information exchange. The third was the development of common data classification levels. The fourth was the development of the necessary framework to support the CISE, which included the definition of access rights to manage the exchange of information and a coherent legal framework.

The CISE has been built based on different pilot and research projects and, until the end of this year, the dissemination and usage of its results (i.a. technological, legal) is expected to start. Some of the projects that contributed to the CISE were the MARSUNO (Swedish Coast Guard, 2011), the BLUEMASSMED (Secrétariat Général de la Mer, 2012), the CoopP (Finnish Border Guard, 2014) and the EUCISE2020 (Italian Space Agency, 2015). In addition, several documents and studies were also produced as a result or to consolidate the achievements of those projects. Some of these are the CISE roadmap (European Commission, 2014a) and its impact assessment (European Commission, 2014b). Finally, the European Commission has also launched various initiatives, namely those funded by the European Maritime Fisheries Fund (EMFF), to complement the results of the core projects abovementioned. One of these initiatives is the last call for projects launched in 2017 (European Commission, 2017c) that is already in its third edition.

### 1.2.2 EU Interoperability Framework

In parallel with the EIS, the European Interoperability Framework for European public services (EIF) (European Commission, 2010c) was presented as a common approach to the delivery of public services. It introduced several new concepts including the four levels of interoperability and interoperability agreements, based on standards and open platforms, and stressed the importance of interoperability governance and the need for coordination across administrative levels.

The four levels of interoperability (European Commission, 2010c) defined were the legal, the organizational, the semantic and the technical. At the legal level, interoperability depends on aligned legislation. Organizational interoperability depends on coordinated processes among organizations that have a mutually beneficial goal. Semantic interoperability depends on the precise meaning of the information exchanged and technical interoperability regards the linking of the different computer systems and services.

Interoperability agreements (European Commission, 2010c) are the formalization of cooperation, at the different interoperability levels, among the different organizations involved, aiming to provide a European public service. At the legal level, such agreements can be specific legislation. At the organizational level, agreements can be memorandums of understanding (MoUs). At the semantic level, agreements can include taxonomies, schemes, code-lists and data dictionaries. Finally, at the technical level, agreements can include interface specifications, communication protocols, data formats and security specifications.

Interoperability governance (European Commission, 2010c) aims to ensure that interoperability is continued over time, in a complex and changing environment due to new requirements, legal context, and new technology and requires a specific framework to govern the various activities at the different administrative levels.

In 2015, considering that interoperability is a prerequisite for efficient connections across borders, between communities and between public services and authorities, the European Commission called for the revision and extension of the existing EIF (European Commission, 2015a). Consequently, in 2017, the European Commission analyzed the state of play and presented the new European interoperability framework as well as the strategy for its implementation (European Commission, 2017b).

The new EIF (European Commission, 2017b) is more focused on how interoperability principles and models should apply in practice and considers emerging policy-related and technological needs. The number of recommendations has almost doubled and is more focused in openness and information management, data portability, interoperability governance and integrated service delivery.

The new EIF is also accompanied by an action plan (European Commission, 2017a) for its implementation until 2020. This plan is organized in five strategic areas and is based on various priorities. During the implementation of this action plan, Member States are expected to implement additional measures, at national level, that complement the plan in a coherent manner.

The principal areas of focus of the new EIF are to ensure the governance, coordination and sharing of interoperability initiatives, 2) to develop organizational interoperability solutions, 3) to engage stakeholders and raise awareness on interoperability, 4) to develop, maintain and promote key



interoperability enablers and 5) to develop, maintain and promote instruments that support interoperability.

### 1.2.3 US Information Sharing Environment

The terrorism-related Information Sharing Environment (ISE) is a critical initiative to strengthen responsible information sharing across communities, agencies, and levels of government to implement goals set forth in the NSISS (The White House, 2012). Accordingly, its purpose is to enhance the sharing of terrorism-related information (The White House, 2007) and its work plan covered an initial period of three years (Information Sharing Environment Program Manager, 2006).

Before the ISE there was a multitude of sectorial information sharing environments scattered by different communities (i.e. intelligence, law enforcement, defense, homeland security and foreign affairs) (Information Sharing Environment Program Manager, 2006). Consequently, its vision *“represents a trusted partnership among all levels of government in the united states, the private sector, and foreign partners, to detect, prevent, disrupt, preempt, and mitigate the effects of terrorism against the territory, people, and interests of the United States of America”* (Information Sharing Environment Program Manager, 2006).

Therefore, the goals of the ISE program are: 1) to facilitate the establishment of a trusted partnership among all levels of government, the private sector and foreign partners; 2) to promote an information sharing culture among ISE partners; 3) to function, in the maximum extent possible, in a decentralized, distributed and coordinated manner; 4) to develop and deploy incrementally information sharing capabilities and 5) to promote more rapid and effective interchange and coordination among the different partners.

As such, the ISE aims to create a powerful capability to share, search, and analyze terrorism information across jurisdictional boundaries and provide a distributed, secure, and trusted environment for transforming data into actionable information (Information Sharing Environment Program Manager, 2006). Consequently, it must incorporate all types of data, at all levels of security, which includes structured and unstructured data and finished intelligence products. Moreover, the ISE will take advantage of and connect existing information sharing capabilities and organizational structures at all levels of government (Information Sharing Environment Program Manager, 2006).

To develop the ISE, the Federal government started by constructing a strong legal and policy foundation upon which to improve information sharing. For example, the President Executive Orders (E.O.) 13311, 13356, and 13388, each of which successively strengthened the sharing of terrorism information across the Federal government. In addition, on December 16, 2005, the President issued a Memorandum to the Heads of Executive Departments and Agencies on the Guidelines and Requirements in Support of the Information Sharing Environment, which specified tasks, deadlines, and assignments necessary to further

the ISE's development. Moreover, the President adopted the majority of information sharing recommendations put forth by the European Commission on the Intelligence Capabilities of the United States Regarding Weapons of Mass Destruction (the WMD European Commission). Furthermore, Congress enacted two laws in addition to IRTPA that provided the Federal government with greater authority for sharing information: The Uniting and Strengthening America by Providing Appropriate Tools Required to Intercept and Obstruct Terrorism (USA PATRIOT) Act of 2001 and the Homeland Security Act of 2002 (Information Sharing Environment Program Manager, 2006).

The results of the implementation of the ISE are already visible. For example, a National Network of Fusion Centers was established, owned and managed by state and local entities, which use the Nationwide Suspicious Activity Reporting (SAR) Initiative (NSI) to share terrorism information among all levels of government; and with consistent policies to protect individual privacy, civil rights, and civil liberties. In addition, there have been increasing levels of collaboration among the fusion centers, the Federal Bureau of Investigation's (FBI) Joint Terrorism Task Forces, Field and Regional Intelligence Groups, Federal, state, and local law enforcement agencies, High Intensity Drug Trafficking Area programs, Regional Information Sharing System centers, intelligence and crime analysis units, and via initiatives like the Fusion Liaison Officer Program, which includes tribal and non-law enforcement partners (The White House, 2012)

Moreover, access has been provided to multiple data repositories across departments and agencies, consistent with mission authorities and legal protections. For example, analysts at the National Counterterrorism Center (NCTC) now have access to over 30 Federal networks containing terrorism information. This profoundly contrasts the pre-9/11 environment characterized by agency-centric data repositories (The White House, 2012)

Furthermore, a single authoritative database of known or suspected international terrorist identities was developed at NCTC. Pertinent information from this database can now be exported to the FBI's Terrorist Screening Center (TSC) database, which also includes domestic known or reasonably suspected terrorist identities, a marked improvement to the previous multiple, non-integrated lists (The White House, 2012)

In 2014, the ISE achievements could be described in numbers as follows (Information Sharing Environment Program Manager, 2015):

- 17 total members of the standards coordinating council
- 4800 suspicious activity reports filed in 2014
- 522 intersystem conflicts prevented by the law enforcement Partner De-confliction Interface
- 23 states represented at the 2015 NGA Summit on state Cyber Security
- 400.000 Registered users of SBU networks who can now access federated search
- 21 out of 37 initiatives supported by ISE from the NFCA National Strategy

- 19 states represented at the 2015 ASCIA Human Trafficking Summit

In addition, the ISE adopted the National Information Exchange Model (NIEM), a successful example of a common way to structure data exchanges to better enable information sharing. NIEM is now used by many Federal agencies, State governments, private sector organizations, and foreign partners. As a side benefit, NIEM promotes information technology (IT) industry adoption as a result of partnering with Standards Development Organizations (SDOs) (The White House, 2012).

Moreover, a plan was established to unify and align user identification and authentication on systems, through the Federal Identity Credential and Access Management (FICAM) framework under the National Strategy for Trusted Identities in Cyberspace. This represented a critical step toward establishing individual accountability and facilitating the appropriate level of information access (The White House, 2012).

Last, but not least, the ISE enhanced communications to facilitate dialogue between departments and agencies and with other partners. For example, the FBI and Department of Homeland Security (DHS), augmented by the Interagency Threat Assessment and Coordination Group (ITACG), hold classified video teleconferences three times a day, 365 days a year, with over a dozen Federal counterterrorism entities. Products of these efforts are available, as appropriate, to non-Federal partners (The White House, 2012).

## **2 Scientific**

### **2.1 Information sharing benefits**

Interagency information sharing (IIS) has been in the research agenda for over 20 years. Although the exchange of information among public services, by using information technologies, has been addressed by researchers before, the term was only coined in 1996 (Dawes, 1996). Afterwards, other equivalent designations have been used in the literature, such as G2G (government-to-government) information sharing (Akbulut et al., 2009; Landsbergen Jr. & Wolken Jr., 2005).

Cross-boundary information sharing is the collaboration or interconnection of different information systems or telecommunication technologies to share data between entities such as groups, departments, and organizations (Landsbergen Jr. & Wolken Jr., 2005). Hence, IIS can also be defined as the cross-boundary information sharing by public services. Depending on the integration objectives, IIS initiatives can be classified as comprehensive, incremental, or selective (Gil-Garcia et al., 2005).

Considering that e-Government is the delivery of government services through the use of information and communication technologies to improve daily operations, reduce costs, and increase the quality of services (Victor Bekkers, 2007; Moon, 2002), interoperability is the technical capability for e-Government interoperation (H. J. Scholl & Klischewski, 2007), which involves providing the proper technical solutions, including hardware and software, and also instituting formal agreements between organizations, adopting standards, and changing business processes (Gil-Garcia et al., 2005; Pardo et al., 2004; Prefontaine & Dawes, 2003). Therefore, the agencies' interoperability maturity stage can vary and be any of the following: 1) experience agency-to-agency; 2) infrastructure support and stage; 3) interoperability between agencies (Landsbergen Jr. & Wolken Jr., 2005).

The objective of the agencies involved in IIS initiatives is to share any of the following five types of information and data (Yang & Wu, 2013): collected raw data, value-added information, administration-oriented information, administration-oriented knowledge, and domain-oriented knowledge respectively. The collected raw data means the data collected directly or indirectly from the public and private enterprises by government agencies. The value-added information is the collected raw data that are further analyzed and refined with the domain knowledge of an agency before sharing to others. The administration-oriented information flows from one agency to another and is defined as the administrative information regarding governmental documents, meeting, activities, etc. The administration-oriented knowledge represents the general knowledge that can be commonly applied to government agencies' daily administrative operations. Lastly, the domain-oriented knowledge is the core-business knowledge of a government agency (Yang & Wu, 2013).

In order to make interagency collaboration and information sharing systems work, the system should be able to provide acceptable Return on Investment (ROI) to the participating agencies (Lee & Rao, 2007).

However, unlike private sector organizations, government organizations share information to generate public goods (i.e., public safety, national security) rather than to maximize the profit of an individual organization (Lee & Rao, 2007). Cost reduction, albeit a major driver in the private sector, was not even among the top five wants and needs in public-sector INT-IS-IOP projects (Hans Jochen Scholl et al., 2012).

IIS has an extensive list of potential benefits, which offer advantages to policy makers, agencies and the public. Such benefits can be political, organizational and technical (Dawes, 1996). In fact, notwithstanding the research in the field, very few empirical studies seem to have been developed so far which evidence these benefits.

### 2.1.1 Political

The political benefits of IIS are, firstly, e-Government development which, in turn, will enable better public services. Consequently, the overall government efficiency and image is expected to improve, leading to less fraud and crime, more safety and security, economic development and quality of life.

In fact, IIS can take e-Government to higher maturity levels (Australian National Audit Office, 1999; Baum & Di Maio, 2000; OECD, 2003; Ronaghan, 2002), hence facilitating its progress (Schooley & Horan, 2007). This will originate better public services (Calo et al., 2012; Siau & Long, 2005a), where they are most needed (Calo et al., 2012), thus enabling the resolution of critical public problems (Calo et al., 2012).

As a result, the government efficiency will improve, thanks to better awareness (Dawes, 1996) and decision making (Calo et al., 2012; Dawes, 1996), which are due mainly to the reutilization of existing information and to the obtention of comparable information (Calo et al., 2012).

Likewise, the government image will also improve (Dawes, 1996), thanks to improvements in transparency (Calo et al., 2012), the promotion of media access to high quality information (Calo et al., 2012), the public access to different government services among different levels of government (Calo et al., 2012), and the public value created, (Dawes, 1996). Consequently, the trust between government and citizens is also expected to improve (Calo et al., 2012).

The increase of e-Government maturity levels will also contribute to a better and greater surrender of public accounts (Calo et al., 2012), to prevent tax evasion (Jing & Pengzhu, 2009) and other illegal activities which take advantage of little communication among government agencies (Jing & Pengzhu, 2009).

Additionally, better security (Baseline, 2006; Calo et al., 2012; Kean & Hamilton, 2004) and safety (Baseline, 2006; Bellamy, 2000; Gil-Garcia et al., 2005; Kean & Hamilton, 2004) can be expected,

particularly in emergency and health services (Calo et al., 2012).

Finally, the economic development is also a benefit of IIS, particularly thanks to the improvement of business productivity through better regulation, which will lead to the improvement of the national competitiveness and citizens quality of life (Calo et al., 2012), namely to welfare increase, as long as appropriate incentive mechanisms are in place (L. Gordon et al., 2002)

### 2.1.2 Organizational

The IIS organizational benefits are multiple and can contribute to the performance of an organization in all the perspectives that balanced scorecard suggests for viewing it (Balanced Scorecard Institute, 2016; R. Kaplan & Norton, 1996):

- Customer perspective: customer focus and customer satisfaction
- Financial perspective: financial data
- Business process perspective (internal process): internal businesses processes. How well the business is running and, and whether its products and services conform to customer requirements
- Learning & growth perspective (organizational capacity): employee training and corporate cultural attitudes related to both individual and corporate self-improvement

From the customer perspective, IIS can support the front-office services to citizens (V. Bekkers, 2009) and provide involved agencies the capability of offering more integrated, diversified, and efficient services to respective target customers (Dawes, 1996; Gil-Garcia et al., 2005; Landsbergen Jr. & Wolken Jr., 2005; Pardo & Tayi, 2007; Zhang et al., 2005; Zhang & Dawes, 2006).

From the financial perspective, IIS benefits are essentially related to the increase of revenues (Kuan & Chau, 2001; Roldán & Leal, 2003) and cost reduction (D. Andersen & Dawes, 1991; Dawes, 1996; Kuan & Chau, 2001; Roldán & Leal, 2003; Walton, 1989). Particularly, the reduction in costs is usually associated to the overall cost of agency operations (Dawes, 1996) and to data processing (Caffrey, 2000) and data collection, information management, information utilization, infrastructure costs (Calo et al., 2012).

No single organization has all the resources necessary to run its activities without inputs from other organizations (Pardo & Tayi, 2007) and there are public needs that no single organization or jurisdiction can handle alone (Dawes et al., 2009). These two circumstances can stimulate and increase the use of information from different data sources (Dawes, 1996; Gil-Garcia et al., 2005; Landsbergen Jr. & Wolken Jr., 2005; Pardo & Tayi, 2007; Zhang et al., 2005; Zhang & Dawes, 2006) , hence IIS which, from the business process perspective, benefits its efficiency in many ways (Calo et al., 2012; Gil-Garcia et al., 2009; Landsbergen Jr. & Wolken Jr., 2005; Luna-Reyes et al., 2007).

IIS contributes to decentralization (Kuan & Chau, 2001; Roldán & Leal, 2003), improve organizational

management (Siau & Long, 2005b), coordination (Calo et al., 2012), improved decision making , high quality services empowerment, greater productivity, integrated services development (D. Andersen & Dawes, 1991; Calo et al., 2012; Kuan & Chau, 2001; Roldán & Leal, 2003; Walton, 1989) and improved coordination (D. Andersen & Dawes, 1991; Roldán & Leal, 2003; Walton, 1989).

Moreover, they also contribute to save time and speedup processes, effective data collection and exchange, business process streamlining, and paper reduction (Lee & Rao, 2007). Government agencies can act faster to identify problems and react with prompt responsiveness (Gil-Garcia et al., 2009; Landsbergen Jr. & Wolken Jr., 2005; Luna-Reyes et al., 2007). solutions of wide-organization problems or the improvement of the organization capabilities (Dawes, 1996).

Improvement of punctuality, consistency and quality of responses, reduction of bureaucracy, complexity and inconsistencies (Calo et al., 2012) and improved communication between government agencies and other related organisms, mass processing tasks and operations of public administration (Calo et al., 2012)

But the effectiveness of the business processes also benefits from IIS (Calo et al., 2012). For example, IIS contributes to solve complex problems (Canestraro et al., 2009; Cresswell et al., 2005; Gil-Garcia et al., 2009; Landsbergen Jr. & Wolken Jr., 2005; Luna-Reyes et al., 2007)

From the learning and growth perspective, IIS can introduce cultural changes, enhance networks, promote the reuse of systems, knowledge and experience, and enhance the information available. In fact IIS helps organizations move from a “need to know” default option to a “need to share” network culture (S. S. Dawes et al., 2009).

Moreover, it can act as a core element of the creation of public sector knowledge networks (S. S. Dawes et al., 2009), broaden professional networks (Andersen & Dawes, 1991; Roldán & Leal, 2003; Walton, 1989) and reinforce valuable professional relationships (Sharon S Dawes, 1996).

Furthermore, IIS promotes the construction of systems, knowledge and experience reusable from one agency to another (Calo et al., 2012) and enables the discovery of patterns and interactions once hidden in millions of separate paper records, and to make decisions based on more complete data (Sharon S Dawes, 1996)

Finally, IIS allows for obtaining comparable (Mendes et al., 2012) and more comprehensive and accurate information for problem solving. Agencies benefit from cooperative activities that improve the quality, quantity and availability of data. Improves the accuracy and validity of the data in each agency’s own programs. More comprehensive picture of a problem or population. Better position to act effectively to achieve its program objectives (Sharon S Dawes, 1996).

### 2.1.3 Technical

The technical benefits of IIS can be grouped into those related to information management, information security and information infrastructure. The information management benefits can be reduced duplicate data collection, processing and storage (Caffrey, 2000; Dawes, 1996; Gil-Garcia et al., 2009; Landsbergen Jr. & Wolken Jr., 2005; Luna-Reyes et al., 2007). The benefits related to information security can be preventing security breaches already reported and responding more quickly with focused actions (L. A. Gordon et al., 2003), hence the cost reduction of related activities (L. A. Gordon et al., 2003). Finally, IIS helps to build an information infrastructure for government operations by encouraging the development of technical standards, shared data centers, telecommunications networks, metadata and other technical resources (Dawes, 1996).

## 2.2 Semantic interoperability

### 2.2.1 Concepts

Semantic interoperability came from the need of computer systems to communicate with each other and is essential to information systems integration (Flahive & Jakobsson, 2008). Early machine-to-machine (M2M) communication systems (e.g. industrial automation systems) were typically closed systems built for a particular purpose, thus did not require it. (Kiljander, D'elia, Morandi, Hyttinen, Takalo-Mattila, Ylisaukko-Oja, Soininen, Cinotti, et al., 2014). However, with the development of communication networks and the realization of the benefits that the interconnection of computer systems could bring, semantic interoperability became an imperative but also a challenging problem (Bishr, 1998; Feng & Flewelling, 2004; Sheth, 1999) and an urgent issue (Kashyap & Sheth, 1996). In fact, without a standard data representation, different applications cannot share and reuse data and will have difficulty finding the data that they need (Strassner & Diab, 2016).

There are several definitions of semantic interoperability available in the scientific literature. For example, it is defined (Flahive & Jakobsson, 2008) as the ability of information to flow between systems, on the basis of shared, pre-established, and negotiated meanings of terms and expressions, such that it is accurately and automatically interpreted by the receiving system. Another example is its definition as the ability of applications, built in different platforms, to exchange data and to communicate between them (Bernstein, 1996; Neiva et al., 2014). Yet another example is that where it is considered that pursuing semantic interoperability is an attempt to gain mutual understanding and agreement between different parties regarding the semantics of their data (Feng & Flewelling, 2004).

Semantic interoperability has, therefore, certain requirements. Namely, the information exchanged must be machine-interpretable (B. Andersen et al., 2014; Ford et al., 2015), unambiguous (Pokraev et al., 2007) and its interpretation must be the same (Macia, 2014), or at least equivalent (Strassner & Diab, 2016), by senders and receivers. Therefore, semantic interoperability covers the technologies needed for enabling the meaning of information to be shared by communicating parties (Kiljander, D'elia, Morandi, Hyttinen,



Takalo-Mattila, Ylisaukko-Oja, Soininen, Cinotti, et al., 2014).

Consequently, in Systems of Systems Interoperability (SoSI), the role of specified and agreed upon semantics is essential (IEEE Computer Society, 1990; Wunder, 2013). In fact, in modern Service-Oriented Architecture (SOA), to reach the objective of publishing, discovering and exploring how to interoperate with services based on their functionality, non-functional properties and data interfaces, it is necessary to specify functional, non-functional and data semantics, and the models used in their specification must be shared across systems (Marco-Ruiz et al., 2016).

For example, in the Semantic Web Services (SWS) domain, there are four different types of semantics to express the various types of system properties and interfaces, (Pedrinaci et al., 2011). These are the functional semantics, that describe the task performed by the system, the data semantics, that describe the services information model, the execution semantics, that describe services exceptional behaviors and, finally, the non-functional semantics that describe other relevant system properties.

### 2.2.2 Benefits

Semantic interoperability is essential to information sharing for four main reasons. First, because it facilitates data location, comparison, integration and reuse. Second, because it facilitates information management, particularly in multidisciplinary contexts. Third, because it enhances decision making and fourth because it reduces development costs and vendor lock.

Semantic interoperability provides services with expressiveness and establishes clear relationships among the data. On the one hand, services expressiveness is necessary to allow the relevant data to be located and reused, without which issues such as those felt in Clinical Decision Support Systems (CDSS) (Marco-Ruiz et al., 2016) will continue to occur. On the other hand, clear relationships between the data used by different systems facilitate their integration. Presently, systems integration can be a very hard task, mainly due to the multiple overlapping standards available, to systems developed based on different standards and to the lack of agreement regarding common standards to be used (Blackman, 2017; W. A. Khan et al., 2014), and semantic interoperability can make this easier.

In the case of the health sector, for example, locating and integrating clinical data across heterogeneous health care systems remains difficult (Sonsilphong et al., 2016). This reality damages the performance of the systems and hampers optimal patient care and experience (Blackman, 2017; Hufnagel, 2009).

In the logistics sector, the lack of semantic interoperability is also a problem. Transportation and handling of goods is, nowadays, an essential aspect of every business, that is under constant pressure to increase its efficiency in areas such as fuel consumption, CO<sub>2</sub> emissions, driver turnover, waiting time and storage space optimization (Ganzha et al., 2017). Consequently, to pursue the desired efficiency, “sensorization” and systems integration are two of the chosen solutions, but they cannot thrive without semantic

interoperability.

On the one hand, more and more sensors gather data on the real-time position and status of goods and transport vehicles, as well as items in the warehouses (Ding, 2013; Zhou Xiaoguang & Long Wei, 2008). On the other hand, although most systems work well on their own, often they cannot pass data to each other. Therefore, the optimization of the supply chain (Ganzha et al., 2017) is hampered, as well as the vision of industry 4.0 (Lasi, H., Fettke, P., Kemper, 2014).

The role of semantic interoperability becomes even more important in multidisciplinary contexts, where things are substantially more challenging, mainly due to technical and linguistic differences. In the defense sector, for example, combined (different branches e.g. air force and navy) and joint (different states) operations are quite common worldwide, and are evermore dependent from the information exchanged among the computer systems involved (Flahive & Jakobsson, 2008).

Another example can be found in the research domain, where a common barrier occurs when it becomes necessary to gather data from various heterogeneous sources to understand complex cause-effects phenomena. For example, to study the impacts of agriculture on water resources, the integration of data from multiple domains, such as agriculture, hydrology, biology, chemistry, and economics, among other, is required (Bonacin et al., 2014).

A final example of a multidisciplinary context where semantic interoperability is essential is that of the Global Internet of Things Services (GIIoTS). The GIIoTS are deployed by companies based on Internet of Things (IoT) resources that are available worldwide. These services rely on essential functions, deployed in cloud data centers, which gather the data from the IoT resources and process it to offer the services. This is done in a seamless way, independently from the technology used by those resources (Kovacs et al., 2016), thanks to the existing semantic interoperability.

Logically, since computers can process amounts of information much faster than humans, if the information received can be interpreted by computers without or with minimal human intervention, then decision making processes can be largely improved by replacing the human element wherever possible by computers (Flahive & Jakobsson, 2008), thus enabling smart processing such as analytic functions, link various data sources and contextualize information (Kovacs et al., 2016). However, this cannot be achieved without semantic interoperability.

Semantic interoperability can also reduce development costs. For example, the development of CDSS is high because of the highly skilled professionals required for knowledge engineering and development tasks (Berner, 2007; Tu et al., 2007), because they are more error-prone (Peleg et al., 2006) and because they have to be maintained by equivalent experts throughout their lifecycle (Marco-Ruiz et al., 2016). Since semantic artifacts are reused across organizations, the effort to develop and maintain those artifacts

is no longer duplicated. In the health sector, this can be very significant, and studies have already pointed out the need to reuse CDSS artifacts across organizational boundaries (Dixon et al., 2013; Kawamoto et al., 2013; Patel & Shortliffe, 2014; Peleg, 2013).

Finally, the lack of semantic interoperability also hampers comparing data from different vendors and transferring data from one vendor to another, originating what is commonly designated as vendor lock (Saaranen et al., 2014).

## 2.2.3 Applications

### 2.2.3.1 Defence

In the military context, the need for semantic interoperability has always existed. However, with the advent of automated Command and Control (C2) systems and the reliance on machine-readable information, semantic interoperability has become even more important (Ford et al., 2015).

At least since 2007, semantic interoperability has seriously been addressed in the sector. In the US, for example, the Air Force developed its Semantic Interoperability Roadmap (Flahive & Jakobsson, 2008; United States Air Force Research Laboratory, 2007), and in Australia it was essential to enable the integration of the Future Combat Capability (FCC) into the future Australian Command, Control, Communications, Computers, Intelligence, Surveillance and Reconnaissance (C4ISR) environment (Flahive & Jakobsson, 2008).

More recently, the North Atlantic Treaty Organization (NATO) has been developing the Semantic Interoperability Logical Framework (SILF) to meet its need for semantically correct interoperability between C2 systems. In addition, semantic interoperability will also help NATO in meeting the need to adapt quickly to new missions and new combinations of coalition partners and systems (Ford et al., 2015).

### 2.2.3.2 Internet of Things

Interoperability is, presently, one of the major challenges to achieve the vision of the Internet of Things (IoT) (Desai et al., 2015). Since the very beginning, IoT solutions were, and still are, mostly use case centric, which led to the creation of IoT silos. Therefore, the inter-silo (or inter-platforms) interoperability became of foremost importance, and achieving it seems crucial for the future of the IoT. Interoperability can, of course, be “hard wired,” enabling total control over the entire process, and giving many possibilities for optimization. Unfortunately, as an approach, hard wiring does not scale, and requires a considerable amount of resources. (Ganzha et al., 2017).

In general, current IoT devices and systems are not interoperable, due to three types of problems: (1) physical layer communication issues from media to protocol, (2) low-level data issues, (3) the inability for applications to use low-level data, and (4) high-level systemic problems. (Strassner & Diab, 2016). In

addition, IoT interoperability requires semantics, to ensure that the meaning of terms and objects in one device or system are not lost or altered when they are exchanged and used by other devices or systems (Strassner & Diab, 2016).

These problems stem, essentially, from the lack of a standard model that represents the characteristics and behavior of an IoT device and the information that it produces and consumes. Without such a model, interoperability is fundamentally compromised. Hence, scalability is limited, operational expenditures increase, and future technologies require one-off siloed architectures for integration. Therefore, the industry needs an interoperable platform on which customizable solutions can be built (Strassner & Diab, 2016).

The GIoT, for example, require interoperability between the locally installed heterogeneous IoT systems and semantic processing is an important technology to enable data mediation as well as knowledge-based processing (Kovacs et al., 2016). In this context, it is reasonable to believe that semantic technologies, based on the application of ontologies (Staab & Studer, 2009), have the best chance to facilitate interoperability among the “things”, as well as across the IoT platforms (Ganzha et al., 2017).

There are several relevant initiatives to develop further semantic interoperability in the IoT. Out of these, we point out the semantic level interoperability architecture for pervasive computing and IoT (Kiljander, D’elia, Morandi, Hyttinen, Takalo-Mattila, Ylisaukko-Oja, Soininen, Cinotti, et al., 2014); the oneM2M project<sup>2</sup> (Ben Alaya et al., 2015), which purpose is to define an international standard of the European Telecommunications Standards Institute (ETSI) for IoT data exchange on a world-wide scale (den Hartog et al., 2015; Kovacs et al., 2016); the Open Mobile Alliance (OMA) NGSI 9/10 standard that enables content and type-based queries; the European Future Internet Platform (FIWARE) that offers a set of cloud enablers for receiving, processing, contextualizing and publishing IoT data and the joint project between Europe and South Korea called World-Wide Interoperability for Semantic IoT (WISE-IoT) (Kovacs et al., 2016).

#### 2.2.3.3 Healthcare

Healthcare is one of the fields where technology advances lead to collecting more and more data from heterogeneous resources (e.g. sensors) (Ganzha et al., 2017). Consequently, interoperability is a key factor for seamless information exchange among health information systems (Wajahat Ali Khan et al., 2014), which explains why it is a global trend in this domain (Macia, 2014). However, it remains a huge challenge, especially considering the over 100 electronic healthcare information standards that currently exist (Ogunyemi et al., 2013).

In addition, the enormous diversity of concepts in biomedical sciences (more than 3,000,000 terms) and

---

<sup>2</sup> <http://www.onem2m.org/>

the difficulty of reaching consensus among experts about the representation of medical knowledge results in extreme variability of the system requirements. This is true even within the same level of complexity of care. Some of the reasons for this extreme complexity lay in the fact that the route of each patient through various healthcare settings is not consistent with every other patient, and the outcomes of any individual encounter may affect the outcome of the following. Consequently, this creates the need for a layer for semantic interoperability between the various information systems; a necessity for the health informatics field (B. Kaplan & Harris-Salamone, 2009) and especially for automated Clinical Decision Support (CDS) (Nogueira et al., 2015).

Hence, a common information format is needed. One where all participants can speak the same language (standards) and interpret similar processes and vocabularies (translation), thus providing the opportunity to achieve seamless exchange of clinical Electronic Health Record (EHR) data among health care entities (Blackman, 2017). Unfortunately, currently no single data standard model exists to achieve semantic health data interoperability between heterogeneous systems (Sinaci & Laleci Erturkmen, 2013; Yu & Hunter, 2013). Consequently, clinical information systems use different data standardization terminology repositories (HL7, LOINC, SNOMED) for the exchange of health data and information, which is a major barrier to EHR interoperability (Sinaci & Laleci Erturkmen, 2013).

In the US, for example, the successful adoption and implementation of EHR systems is crucial to the health care industry (United States Department of Health and Human Services, 2014). With the enactment of the Affordable Care Act (2010), the push for a national health information database continues to be a key discussion point at various levels. However, the reluctance to adopt a comprehensive EHR solution is also very prevalent, and one of the primary reasons for this reluctance is the inability of the EHRs to interlink and communicate with each other due to the lack of a comprehensive data standard that facilitates the exchange of data using a common data model (Bowles et al., 2013). In Europe, on the other hand, shared clinical terminologies and ontologies, as means to enable the faithful exchange of the meaning of information, have been addressed in the EU Semantic Health interoperability roadmap (Martínez-Costa et al., 2014).

#### 2.2.3.4 Labor, education and training

In the labor, education and training sector, to achieve semantic interoperability throughout Europe, the EC is developing the multilingual European Skills, Competences, Qualifications, and Occupations (ESCO) classification, which offers a reference vocabulary for the labor market and for the education and training sectors. ESCO does not directly provide services to citizens; rather, it is a semantic asset that can be used to improve online tools. ESCO can enable competence-based job matching and aims to enable data exchange between private and public employment services that use various National Occupations Classifications (NOC) and languages (Ie Vrang et al., 2014).

#### 2.2.3.5 Energy

In the energy sector, for example, about two thirds of the energy consumed in buildings originates household appliances. Nowadays, appliances are often intelligent and networked devices that form complete energy consuming, producing, and managing systems. Reducing energy is therefore a matter of managing and optimizing the energy utilization on a system level. Consequently, these systems need standardized interfaces on a sensor and device level to enable further extensions. However, in spite many of the required standards already existing, a common architecture does not, and so the market is becoming too fragmented and powerless. To overcome this, a reference ontology for these appliances is being designed using the Ontology Web Language (OWL) (den Hartog et al., 2015).

#### 2.2.3.6 Industry

Enterprise interoperability is an emerging need in Europe for joint projects and businesses facing new marketing challenges (Seleng et al., 2015). Particularly, in the engineering domain, where the use of semantic web technologies, such as ontologies and semantic web rule languages for the exchange of “intelligent” Computer-Aided Design (CAD) models among different systems, while maintaining the original relations among entities of the model is being investigated (Abdul-Ghafour et al., 2014).

#### 2.2.3.7 Agriculture

In agriculture, some relevant initiatives revolve around the collaboration of systems to share information that is essential to research in this domain. Agriculture is both highly dependent on water resources and impacting on these resources. Regardless of advances in the area, the impacts of water scarcity and climatic changes on agriculture, as well as the impacts of agriculture on water resources, remain uncertain. Potentially, collaborative systems can support the management and information sharing of multifaceted and large scale data sources, providing valuable and indispensable information for research, and so semantic interoperability plays a key role in this domain as well (Bonacin et al., 2016).

#### 2.2.3.8 Research

The situation just described in the agriculture sector is a typical scenario that requires multi, inter and transdisciplinary collaboration among scientists from several domains to improve research globally. Knowledge organization, integration and recovery technologies are crucial to enable such collaboration where scientists must access, trust and understand shared information (Bonacin et al., 2016). In this regard, the OntoAgroHidro is an ontology to represent knowledge about the impacts of climatic changes and agricultural activities on water resources. The objective is for the ontology become a component of Embrapa’s research network system (AgroHidro), which aims to support integration and information sharing among a range of institutions and researchers. There are four planned applications that will make use of the ontology: semantic search mechanisms, knowledge visualization mechanisms, conceptual support tools, and expert systems (Bonacin et al., 2016).

#### 2.2.3.9 Environment

In the environmental domain there are also plenty of interesting initiatives involving semantic interoperability. For example, the Coral Reef Ecological Observatory Network (CREON) implemented a solution for information sharing and interoperability (K. Jaroensutasinee, M. Jaroensutasinee, S. Bainbridge, T. Fountain, S. Holbrook, 2012). It uses Ecological Metadata Language (EML) to describe data generated by its members focusing on observational data. It also proposed the Semantic Observations Network (SONet) as part of the Semantic Tools project. EML is an Extensible Markup Language (XML) schema, which describes ecological data using the resource conception from Dublin Core (DC) (Bonacin et al., 2016).

The SemantEco project (Patton et al., 2014) faces similar problems for dealing with distinct data sources and so integrates them under a proposal for the Semantic Ecology and Environmental Portal (SemantEco). SemantEco offers decision support tools that aim to help resource managers identify different environmental scenarios. It also considers the reuse of ontologies to improve the usability and interoperability of the system (Bonacin et al., 2016).

Xiaogang Ma et al. (Ma et al., 2014) employed semantic web tools to provide reliable information for the national climate assessment. Their objective was to increase understanding, credibility and trust in the research conducted on climate change. Therefore, they developed an ontology model of the Global Change Information System (GCIS) by applying a series of use cases to identify goals and other elements of the domain. They used software tools like CMapTools4 to easily interact with the users and environmental scientists. They reused ontologies to achieve and improve interoperability as well as system usability (Bonacin et al., 2016).

Cuahsi is a consortium of over a hundred universities and US organizations focused on the hydrology domain. A total of 4090 concepts were modeled on the Cuahsi ontology. The main sources of information provided by the consortium are temporal series, previously classified according to metadata described using tags and a controlled vocabulary. To overcome interoperability problems they developed the Hydrologic Information System (HIS) (Tarboton et al., 2011). In addition, they use WaterML (Open Geospatial Consortium, 2012), an XML based language designated as the water communication language, to retrieve information providing location, time series, and variables in a standardized way (Bonacin et al., 2016).

Finally, the National Aeronautics and Space Administration (NASA) Jet Propulsion Laboratory (JPL) has developed a set of 200 ontologies with around 6000 earth science concepts (Raskin & Pan, 2005). Each of these ontologies can be visualized (and reused) individually. The NASA-JPL classifies SWEET as middle-level ontology, where users can add domain specific components. (Bonacin et al., 2016).

## 2.2.4 Challenges

Data heterogeneity is the first and foremost reason why semantic interoperability is needed. Simply put, when the same concepts are modelled differently, in different applications, we need semantic interoperability to exchange information among those applications. For example, one of the major barriers to electronic health information interoperability is the heterogeneity of clinical data sources that operate on the foundation of data standard models that restrict the exchange of data external to its domain (Fernández-Breis et al., 2013).

At the technical level, this heterogeneity can be found in three levels (B. Andersen et al., 2014). One is the object level, where information objects cannot clearly be identified as instances of real-world entity classes. Another is the attribute level, where we can find ambiguous identifiers for attributes, poorly-defined data types, and implicit semantics in attribute hierarchies. And the last is the value level, where there are diverse formatting and units of measure and non-standardized coding tables are used instead of controlled vocabularies. For example, the systems in a health network usually employ different standards and terminologies (Marco-Ruiz et al., 2016; Moreno-Conde et al., 2015).

Then, we have the complexity inherent to the information models used, since modelling real world concepts, which are often complex, implies having complex information models. An example of this are healthcare systems, where the dynamic nature of biomedical sciences and systems creates difficulties in achieving their semantic interoperability and maintenance (Nogueira et al., 2015). For example, Dixon et al. (Dixon et al., 2013) and Wright et al. (Wright et al., 2015) detected major challenges to enable client-service SIOp related to difficulties in understanding the semantics of the CDS service interfaces when sharing CDS services among 4 organizations (Marco-Ruiz et al., 2016).

While implementing semantic interoperability solutions, we also often face challenges related to socio-cultural differences. A good example of this is during the development of agreements stating the precise meaning of the exchanged data. According to (Morris et al., 2004) a lesson learned from CASE tool integration is that a primary barrier to increased interoperability is the difficulty of reaching such agreements (Flahive & Jakobsson, 2008). This can be, in part, due to stakeholders having different backgrounds, heterogeneous expertise, unique knowledge, particular needs and specific practices (Bonacin et al., 2014; Liao et al., 2014).

For example, the approach used by healthcare domain experts to interpret and express healthcare concepts, which can vary based on culture, geographical location and educational background is an additional challenge (de Lusignan et al., 2011). Some typical difficulties of knowledge engineering processes include the multi-disciplinary nature of knowledge involving teams of professionals from various fields and specialties and language and communication problems between experts, due to different nationalities or schools of thought. Such difficulties are found directly related to elements in the human processes of cognition, meaning and communication (Bonacin et al., 2016).



Another challenge is related to the approach taken during the development of information models. If, on the one hand, in the IoT, one of the reasons why semantic interoperability is hard to achieve is because of the typical bottom-up proprietary approach in developing applications (Desai et al., 2015). On the other hand, the top-down approach used to develop standards is also considered a barrier to interoperability in healthcare applications (Luz et al., 2015).

Usually, IoT applications are deployed in a bottom-up (sensors, gateways, service and application) manner from a common provider. These providers control the sensor data and data structures, which help them to create intelligent application on top of it. Due to the proprietary approach employed by these providers, the IoT domain has turned into a domain of vertical silos of various IoT applications with no horizontal connectivity between them. In fact, many vendors do not provide open, interoperable frameworks that enable semantics to be defined and managed for using their IoT devices (including the software and applications that works with their IoT devices) (Strassner & Diab, 2016). Consequently, this lack of interoperability with independent services presently endangers the wide acceptability and adoption of the IoT domain, especially for applications that can benefit from multiple devices (Desai et al., 2015).

Simultaneously, the top-down approach of all healthcare informatics standards has been one of the barriers to wider interoperability of healthcare applications (Luz et al., 2015). The life cycle of HL7v3 has shown some development that highlight the challenges of achieving semantic interoperability in healthcare especially using a top-down modeling approach. According to the HL7v3 specifications, the Reference Information Model (RIM) is the cornerstone of the software semantic interoperability on those systems, and relies on open research issues such as reuse, alignment and mappings of ontologies (Bonacin et al., 2014).

Isolated developments are, in fact, a challenge to semantic interoperability. There is evidence that the isolated adoption of terminologies, classifications or ontologies has not been effective in delivering the desired ability to communicate semantically valid extracts of information between independently developed, distributed applications (Kalra & Blobel, 2007). So, in order to effectively communicate, both structure and semantics must be decidable between the communicating parties (Nogueira et al., 2015).

However, unfortunately, the distributed nature of ontology development has led to ontological heterogeneity for the same or overlapping domains. For example, in the research domain, the heterogeneity of data sources creates a barrier to scientists trying to establish connections among multiple domains of information (Bonacin et al., 2016). Another example is that as the need to exchange healthcare data continues to grow, the inability to share and communicate patient data across the systems becomes impossible due to the varying data standardization models that are adopted by the health systems, which can only ensure interoperability within its own operational domain (Sinaci & Laleci Erturkmen, 2013) (Blackman, 2017).

Although the field of ontology matching is improving, some challenges have to be addressed such as: 1) large-scale matching evaluation, 2) efficiency of matching techniques, 3) matching with background knowledge, 4) matcher selection, combination and tuning, 5) user involvement, 6) explanation of matching results, 7) social and collaborative matching and 8) alignment management: infrastructure and support (Pavel Shvaiko & Euzenat, 2013).

Another challenge to semantic interoperability is that, often, the right stakeholders are not involved. A critical problem in defining and representing semantics is that, while there are many ontologies being built, most are developed by domain experts and not by semantic web experts. Hence, semantic web best practices are not followed and so those ontologies cannot be reused. On the one hand, users not trained in linguistics and first order logic will often produce poor ontologies. On the other hand, good ontology developers often lack the deep domain expertise to create useful and pragmatic ontologies. Therefore, both have to be involved in the process (Strassner & Diab, 2016).

The number of standards available is also a challenge. The semantic web proposes the use of knowledge representation languages to understand and organize the information produced and shared through the Web. Nevertheless if, on the one hand, some researchers claim that there is a lack of a de facto standardization of models and languages, besides the existence of multiples proprietary solutions (Bonacin et al., 2014). On the other hand, other researchers claim that many of the required standards already exist. Some being formal, and other industry or proprietary standards. Hence, the main issues are the lack of a common architecture, and the fact that individual standards cover a smaller or larger part of the problem, sometimes overlapping and competing (den Hartog et al., 2015).

The complexity and limitations of existing solutions also create difficulties. Nowadays, implementing semantic interoperability is a real challenge for the enterprises of any size, especially for small, medium and micro enterprises. Although there are already plenty of interoperability formats and standards (Core Components, EDI, ebXML) established, they are rarely used due to their complexity (Seleng et al., 2015). In the healthcare domain, for example, standards are reportedly hard to use because of four main reasons (Macia, 2014). First, interoperability standards (HL7, 1987; IHE, 2016) provide limited mechanisms to validate the information to be exchanged (e.g. constraints of clinical concepts). Second, they do not focus on ensuring the same interpretation of the exchanged information from one health information system to another. Third, the adoption of health interoperability standards is not trivial since it requires high effort, technical expertise as well as clinical domain knowledge. Finally, the combined use of standards to achieve semantic interoperability is a field of research (Dentler et al., 2013; Garde et al., 2007; Menárguez-Tortosa & Fernández-Breis, 2011).

Language differences also contribute the the challenging task that is developing semantic interoperability. A language-level difference means that ontologies are written in different formalisms, some of them possibly being more expressive than the others or offering different sets of constructs. Consequently, in

such cases, a normalization process needs to occur. Usually, this means a translation of all formalisms into the one used by the ontology that requires most expressiveness.(Ganzha et al., 2017)

Then there are few reports on successful implementations. The uptake of controlled vocabularies has not been followed by enough reports on the successful exchange of semantically coherent extracts of information between different applications. The few reports of successful implementation were in extremely controlled situations, which has not led to any significant implementations for situations that are typically found in the reality of the healthcare systems (Lewis et al., 2008). (Nogueira et al., 2015). To date, there are no scientific investigations published in academic journals, on the capability of the FHIR technology to provide semantic interoperability (Luz et al., 2015).

Finally, there are quite some open research topics hampering the development of semantic interoperability, including the reuse, alignment and mappings of ontologies (Bonacin et al., 2014). Beyond the typical data-level conflicts (Liu et al., 2007; Ram & Jinsoo Park, 2004) such as data type, data format, data value, and data scaling conflicts, there are additional kinds of data-level conflicts, such as data aggregation, data value property conflicts, property concept conflicts, and data value concept conflicts (Arch-int & Arch-int, 2013) requiring resolution, which suggests the need for future study (Sonsilphong et al., 2016).

Differences at the ontology level arise when there are competing views on the same domain. The problem of matching ontologies (also known as mapping or alignment) has been extensively studied over the years (Euzenat & Shvaiko, 2013; Otero-Cerdeira et al., 2015) and many approaches to overcome it have been proposed (Heflin & Song, 2016; KALFOGLOU & SCHORLEMMER, 2003; N.F. Noy, 2009; Pavel Shvaiko & Euzenat, 2013).

However, while some provide open data models for syntactic interoperability, none provides an open and extensible semantic model for achieving semantic interoperability. The reason for this is that a data model is defined as a technology-dependent mapping of the contents of an information model into a form that is specific to a data store or repository. Consequently, the protocol, language, and other implementation features, used in a data model, vary in their ability to convey semantics (Strassner & Diab, 2016).

Although numerous tools and methods for combining ontologies have been proposed, none of them works fully automatically. Nonetheless, using the semantic web approach to interoperability still has many advantages. For example, if it is feasible to combine the ontologies of the IoT platforms, it is possible to employ semantic reasoning for the discovery and matching of data and various services offered by them (Ganzha et al., 2017).

Finally, despite the perfection of the Archetype Definition Language (ADL) as a formalism to describe healthcare concepts, its successful implementation outside the academic environment, in real healthcare

information systems that are able to share data between distributed applications developed independently is still a question to be answered (Kashfi & Torgersson, 2009).

## 2.2.5 Techniques and technologies

### 2.2.5.1 Common information models

Common information models should be used to exchange information for cost-effectiveness reasons. If two systems that we wish to make interoperable use different information models, then we should develop their semantic interoperability. In this regard, if the extent to which they need to exchange information is very small, then most likely we do not need to develop a model dedicated to the information exchange, and it is manageable for both systems to adjust to each other's definitions. However, if the number of systems involved or the information to exchange increases, then the costs of this solution will be significantly higher, in which case a common information model should be developed to support the interoperation (Flahive & Jakobsson, 2008).

In the smart appliances domain, part of what is needed is a unified data model for appliances and corresponding Application Programming Interfaces (APIs), which can be used by developers of energy-saving applications for generic types of appliances without the need to know specifics of the various standards (Starsinic, 2010).

Common information exchange models should be formal and standardized. To this end, the knowledge representation languages proposed by the semantic web are one of the possibilities to do it (Bonacin et al., 2014). Examples of such models, presently being used or under development, to support large-scale information exchange are the JC3IEDM (NATO Multilateral Interoperability Programme, 2016), the US National Information Exchange Model (NIEM) (The NIEM Community, 2005) and the EU Maritime Common Information Sharing Environment (CISE) information model (Italian Space agency, 2017).

The Multilevel Model-Driven (MMD) approach, introduced by the openEHR Foundation (OpenEHR, 1998), to provide a sustainable solution for semantic interoperability, has been adapted for compliance with Semantic Web technologies and the Internet of Things by the implementation of the MMD principles in XML technologies (Cavalini & Cook, 2014). The XML-based MMD approach is proven effective to provide semantic interoperability, but implementations are needed to increase its uptake. Hence, there are studies aiming to demonstrate its implementation and validity (Nogueira et al., 2015).

Another approach is based on the construction of information models based on collections of semantic hyperlinks (Koster, 2014). But this entails some shortfalls (Strassner & Diab, 2016). Firstly, information models typically contain more details, such as the semantics of the relationships between information entities and the elements it contains (i.e. association classes and attributes). Secondly, for computers to select automatically the most appropriate hyperlink, a detailed knowledge of the semantic is required, which such hyperlinks cannot contain.

Controlled vocabularies are essential, successful and thus a common approach in healthcare. have an essential role in the standardization of medical knowledge representation models, and many projects have succeeded, to some extent, with this approach (Knaup et al., 2007). In fact, the most common approach for developing semantic interoperability among healthcare applications is to use controlled vocabularies (terminologies, classifications and ontologies) (Ganguly et al., 2005).

#### 2.2.5.2 Similarity measurement

Assessing the similarity of information models is important and there are many ways to do it. Quite often, the information models of the systems to be integrated have similarities, especially if they are from the same business domain. Measuring this similarity is relevant to achieve semantic interoperability (Feng & Flewelling, 2004) and the process is called semantic similarity measurement. Several approaches can be found to accomplish it, in the information science field (Feng & Flewelling, 2004).

Various situations can occur when we compare two different information models from the semantic point of view. These situations have been divided into the following five types (Flahive & Jakobsson, 2008): 1. Exact Match (Same Name, Same Meaning), 2. Synonyms (Different Name, Same Meaning), 3. Homonyms (Same Name, Different Meaning), 4. Partial Similarities and 5. No Match (Different Name, Different Meaning). Out of these, partial similarities are the most difficult to deal with, because the pieces of information overlap. Having present these different situations is essential to define precisely how the information in one model maps into another model (Sonsilphong et al., 2016).

Sometimes it is not even possible to exchange some data. For example, it was reported that, during the exchange of data between two ontologies, some instances in an ontology could not be transferred to the other ontology due to the lack of equivalent concepts in the target system (Patil et al., 2005).. In this case, some of the reasons that hamper the detection of exact correspondences between the concepts were identified. For example, same concepts may have different structures in their applications, with more or less attributes (Abdul-Ghafour et al., 2014).

Many of the approaches proposed for aligning ontologies at the semantic level are based on the similarity measure between different entities that are semantically “similar” (Abdul-Ghafour et al., 2014). In this regard, different approaches of similarity measure can be found in the literature (Euzenat & Shvaiko, 2013), from which two main models can be distinguished. The geometric or multidimensional models (Nosofsky, 1992) and the feature contrast model (Tversky, 1977).

In the multidimensional models, entities are described in the form of a limited set of dimensions, where each dimension is an axis in space. Thus, an entity is defined by its coordinates in the space of axes (dimensions) and receives a value for each dimension that defines it. The proximity between the objects in this space reflects their similarity. On the other hand, in the contrast model, concepts are defined as a list of attributes. For example, Tversky (Tversky, 1977) proposed such a model where the similarity

measure is based on a formula involving both common and distinctive attributes of the compared entities (Abdul-Ghafour et al., 2014).

There are some problems that come from addressing semantic interoperability with standards coming directly from the semantic web (RDF, RDFS3 or OWL4). These include the exponential complexity of inference techniques on rich models; unavailability of exhaustive semantic description of the problem area; and the problem of contradictory knowledge (Seleng et al., 2015).

Tversky proposed one approach based on features (Tversky, 1977). In this approach, semantic similarity is defined as a feature matching process. In this approach, features describe the characteristics of a category (e.g. color) and the more features categories have in common, the more they are similar, from the semantic point of view. This approach also entails a factor to support features with different importance. This approach has shown convincing results when used to determine the semantic similarity between spatial entities (Rodriguez et al., 1999).

Rada et al., proposed one approach to measure semantic interoperability that consists in calculating the conceptual distance of two categories in a taxonomy. In this case, the distance is given by the number of links that connects those categories within the hierarchical structure (Rada et al., 1989). In this context, a small number of links means a short distance, hence higher semantic similarity. However, if we consider that the distances between two categories may have different importance, then we should assign different weights to the links reflecting that (Richardson & Smeaton, 1996).

Euzenat et al., (Euzenat & Valtchev, 2004) defined a similarity measure method of OWL Lite ontologies based on two factors: the entity category (class, instance, property, etc.) and the set of characteristics related to a category (e.g., super-classes, properties, and instances). This method has the advantage of considering OWL Lite ontologies specifications, e.g. classes and properties hierarchy, restrictions on classes, and properties characteristics.

Patil et al., (Patil et al., 2005) defined another similarity measure method, based on the “Contrast Model”, between OWL DL ontologies for the exchange of data semantics of a product model. It defines a global function of aggregation in terms of similarity and local functions based on the concepts descriptions and their context. However, the local functions do not consider the similarity of attributes to compare. That is, the classification is based strictly on exact equivalences.

Zghal et al., (Zghal et al., 2007) defined another method for measuring similarity for ontology alignment in OWL DL, called Structural Alignment Ontology OWL-DL (SODA). The method defines a local and a global method for calculating similarity, and combines the local similarity measure (structural and terminology) for the evaluation of the global similarity measure.

Sim-DL (Janowicz et al., 2007) is also a method for semantic similarity measurement for OWL DL

ontologies, proposed for information retrieval in the domain of geography. The method is appropriate to ALCNR variant of the description logic and is implemented with the Protégé ontology editor.

Abdul-Ghafour et al, have recently proposed another approach for measuring semantic similarity. They have extended their integration methodology with a similarity-based approach providing means for ‘approximate’ semantic mapping between entities having no equivalence in target systems (Abdul-Ghafour et al., 2014).

Finally, another approach consists in the automatic identification of similarities, instead of doing it manually. An ontology manager within SILF can provide services for ontology operations that identify similar concepts across ontologies and match and align them automatically without relying on handcrafted solutions. In this case, translation rules are the output of the mappings between concepts in systems A and B ontologies, their Semantic Descriptions and the Common Ground. Transformation is used to convert a message from a form, communicated by system A into a form, which can be interpreted correctly by the receiving system B (Ford et al., 2015).

#### 2.2.5.3 Ontology matching

Ontology is a type of common agreement on the conceptualization of terms in a specific domain of interest (Gruber, 1993). The reason for such agreements is that there are many types of differences that need to be overcome to achieve semantic interoperability between ontologies. Some of these differences (Klein & Fensel, 2001; N.F. Noy, 2009) can be divided into 2 main groups: language-level and ontology-level (Ganzha et al., 2017).

In various sectors of activity there is no common globally agreed-upon standard or standardization of formal semantics. Instead, different systems annotate data under different standards (Sonsilphong et al., 2016). Consequently, to exchange information among these systems, the dominant approach so far has been to create translations between all individual assets (den Hartog et al., 2015), which is not so cost-effective.

To reduce this need, a reference ontology may be defined, where the core concepts recurring in a certain domain are explicitly specified, their relationships, as well as mappings to other concepts used in different ontologies (den Hartog et al., 2015). This process is known as ontology mapping, and it reconciles the conflicts that may exist between the different ontologies considered (Sonsilphong et al., 2016). In the IoT, for example, the definition of a universal language or even of a set of data models commonly agreed upon are not found likely to happen and, for this reason, the usage of ontology mappings is considered a solution for improving interoperability in the domain (Strassner & Diab, 2016).

An additional advantage of using a reference ontology is that it enables the creation of abstraction layers and corresponding common Application Programming Interfaces (APIs) that can be addressed by

application developers without needing to know the details of the remainder ontologies involved (Starsinic, 2010).

When using a reference ontology, each of the specific data definitions are mapped into a general normalized form that is used for processing, and afterwards the results are mapped back to the specific definitions (Strassner & Diab, 2016). The correspondences between the different ontologies, which are essential for automated interpretation, have the form of language-to-language mappings (if different ontology languages are used) or term-to-term mappings (if the ontology languages are the same but domain terms are named differently). In some cases, where the models differ in terms of the scope or granularity of the covered domains, model transformations may be required (Ford et al., 2015).

The usual approach to dealing with differences between ontologies entails two steps: 1) determine an alignment and 2) interpret it, according to its intended application. An alignment is a set of correspondences between semantically related entities of ontologies. Alignments can be of various cardinalities 1:1 (one to one), 1:m (one-to-many), n:1 (many-to-one) or n:m (many-to-many), and ontology matching regards finding these correspondences. As soon as the alignments are established, they are typically used to support tasks such as ontology merging, data translations and query answering (Pavel Shvaiko & Euzenat, 2013).

Ontology matching can be performed statically (in design time) or dynamically (in run time). Some of the applications that require dynamic ontology matching (Euzenat & Shvaiko, 2013) are peer-to-peer information sharing, web service composition, search and query answering (Pavel Shvaiko & Euzenat, 2013).

Some of the approaches, to enable the semantic integration between ontologies represented with OWL-DL, in a way that minimizes human interaction, are based on inference mechanisms provided by reasoners (e.g. Pellet). Additionally, axioms and rules are represented with SWRL (Semantic Web Rule Language) and used to enable terms to be reasoned as being equivalent semantically, even if they are using different terminologies. Then, ontologies reasoning ability is used to recognize automatically additional mappings between entities. To identify entities which have no equivalent correspondence, a similarity-based approach can be used (Abdul-Ghafour et al., 2014). Other approaches use XML Schema Domain Models incorporating RDF triples to incorporate information to the Semantic Web using Linked Data tools. (Luz et al., 2015).

The literature includes various studies about using ontology mapping techniques to enable the interoperability of services and applications (Panetto et al., 2012; Zheng & Terpenney, 2013). According to various surveys (Choi et al., 2006; Euzenat et al., 2013; Pavel Shvaiko & Euzenat, 2013), many studies have focused on ontology matching techniques to solve the semantic heterogeneity of ontologies by creating a semi-automatic approach to ontology merging and alignment without dealing with data



integration or transformation (Fürst, F., & Trichet, 2009; Hu et al., 2008; Jean-Mary et al., 2009; Juanzi Li et al., 2009; Wang et al., 2013).

The literature also includes various solutions (Batini et al., 1986; Spaccapietra & Parent, 1991), surveys (Choi et al., 2006; Doan & Halevy, 2005; Gal & Shvaiko, 2009; KALFOGLOU & SCHORLEMMER, 2003; Natalya F. Noy, 2004; Rahm & Bernstein, 2001; P. Shvaiko & Euzenat, 2005) and books (Bellahsene et al., 2011; Euzenat & Shvaiko, 2013) on ontology matching.

The DOLCE-UltraLite ontology (DUL) is one approach proposed to provide semantic interoperability for ontologies that are built using an upper ontology. DUL is an “upper ontology”, hence it describes a set of generic concepts that are the same across multiple knowledge domains and so it does not describe domain concepts, as well as generic concepts such as time and location. These are intended to be included from other ontologies via OWL imports (Strassner & Diab, 2016). The Sensor and Sensor Network ontology presented in (Barnaghi et al., 2011) is based in part on the DOLCE-UltraLite ontology (DUL) (Association for Ontology Design & Patterns (ODPA), 2009).

The SILF framework is another proposed approach. It covers both aspects, mapping and transformation, which are included as part of mediation/translation rules. This allows each message between communicating parties to be provided with references to one or more of the ontologies required for interpreting that message. SILF, initially introduced in (Bacchelli et al., 2010) is a high-level view of such an architecture that supports semantic interoperability among heterogeneous information systems (Ford et al., 2015).

Some approaches are more focused on conflict resolution. For example, Biletskiy et al. (Biletskiy et al., 2010) proposed an approach for mapping the ontologies of heterogeneous information sources that aimed at naming and entity identifier conflicts. The proposed approach created rules for resolving naming conflicts, and identified the homonym and synonym of different instances in ontologies. Another example is that of Arch-int et al. (Arch-int & Arch-int, 2013) that proposed the Semantic Bridge Ontology (SBO), which resolved certain types of structural conflicts such as naming, generalization, and isomorphism conflicts as well as property and concept discrepancies, setting aside data-level conflicts (which generally exist in the processes related to ontology mapping).

Some other are focused on different challenges. For example, Kumar and Harding (Kumar & Harding, 2013) proposed an ontology mapping approach, employing description logic based on bridging axioms between the ontologies to achieve an interoperability of knowledge and data sharing among small- and medium-sized enterprises to promote the form of virtual enterprises. Another example is the Systemic Methodology for Ontology Learning, proposed by Gil and Martin-Bautista (Gil & Martin-Bautista, 2014), which is based on heterogeneous source ontologies to support data integration and the complementary knowledge acquisition processes. Yet another example is that of (Abdul-Ghafour et al., 2012) to share

Computer Assisted Design (CAD) models was proposed based on the construction of the Common Design Features Ontology (CDFO), which used as an *interlingua* for the exchange of product data (Abdul-Ghafour et al., 2014).

Ontology matching is presently being used in various ways. For example, some recent ontology matching systems are SAMBO, Falcon, DSsim, RiMOM, SAMOV, Anchor-Flood and AgreementMaker. These systems can be classified in different ways, and some of the criteria that can be used are the format of the ontologies used (e.g. OWL, RDFS, SKOS, XML and N3), the type of alignments performed (e.g. 1:1, 1:m and n:m) and the algorithms used (e.g. n-gram, UMLS and Vector distance) (Pavel Shvaiko & Euzenat, 2013).

In the health sector, the advent of different health standards, such as Health Level Seven (HL7) enables health information systems to integrate by communicating standard information (HL7, 1987). Other health standards, such as the Integrating the Healthcare Enterprise (IHE) (IHE, 2016), define integration guidelines based on established data standards (e.g., HL7). Its main goal is to integrate health standards for effective interoperability and efficient workflow (Macia, 2014).

Also in the health sector, the openEHR Foundation (OpenEHR, 1998) prescribes the use of archetypes for describing clinical knowledge in order to achieve semantic interoperability between these systems. (Cardoso de Moraes et al., 2016). It has defined an open architecture based on a two-level model that separates information from knowledge.

#### 2.2.5.4 Ontology mapping detection and conflicts resolution

Ontology mapping detection and conflict resolution techniques are needed. Since there are still data conflicts, for example in various EHR systems, there should be techniques at least semi-automatic in resolving the conflicts, to reduce the effort of making manual mappings (Sonsilphong et al., 2016). Proposals in this direction include the rule-based ontology mapping system called Semantic Ontology Mapping for Electronic Health Record Data (SEMED) to enable health-care data integration and semantic interoperability (Sonsilphong et al., 2016). In addition, there is a proposal (Arch-int & Arch-int, 2013) for structural conflict detection and resolution techniques to resolve ontology heterogeneity, enabling interoperability between existing shared learning resource systems through the common ontology of learning resources.

Another proposal (Giunchiglia et al., 2012), is a method for structural conflicts resolution (equivalence, generalization, and disjointness) between heterogeneous ontologies, aiming at reducing the number of mapping rules for the minimalistic mappings (Sonsilphong et al., 2016). This method classifies different types of conflicts and entails a systematic way to generate automatically a semantic mapping system using a rule language (Sonsilphong et al., 2016). This method succeeded in achieving interoperability between the ontologies used, which were merged into a global ontology. However, it failed in supporting

the detection and resolution of data-level conflicts. In addition, it does not provide a semantic conflict representation model that can be used to automatically derivate bridging rules (Sonsilphong et al., 2016).

#### 2.2.5.5 Information enriched with ontologies

One of the widely recognized methods to deal with semantic gaps is to semantically enrich the exchanged information through an ontology. Several studies highlighted and proved the advantages of applying semantic annotations on various kinds of models, which represent a product from different perspectives (Liao et al., 2014). For example, the ontology proposed by Qin et al. (Qin et al., 2017) was found to enable the automatic check of consistency, reason out the new knowledge and implement the semantic interoperability of Composite Positional Tolerance (CPT) information.

In addition, according to Ganzha et al., the common interpretation of data and information, based on a shared ontology (or, more likely, multiple shared ontologies), is the best way to achieve semantic interoperability. The advantage of this is that it allows to exchange information such that the meaning of it will be automatically interpreted by the receiver in order to produce useful results (Ganzha et al., 2017).

In this context, Liao et al. developed a study (Liao et al., 2014) mainly to deal with semantic interoperability issues by introducing a formal semantic annotation framework. The conclusions were that two aspects of semantics are needed to be made explicit by a semantic annotation: (1) structure semantics, describing the interrelations between an annotated element and the other elements that it is related to and (2) domain semantics, describing the context and the meaning of an annotated element in a selected domain.

A common approach to tagging ontologies is the Lightweight Semantics approach (M, Laclavík et al., 2012; Seleng et al., 2014). It is based on the idea that users can attach tags or annotations to their data and documents. These tags/annotations can be added either manually or automatically using the annotation tool Ontea (Laclavík et al., 2009) or 3rd party Named Entity Recognition (NER) tools, such as Illinois NET5, StanfordNER6, GATE's ANNIE7 and Apache OpenNLP8 (Seleng et al., 2015).

A good example of where enriching annotations with ontologies could make a significant difference is the case of IoT. The traditional paradigm of the IoT service model is to provide raw sensor data to the software agent, captured from the heterogeneous sink nodes. However, this raw sensor data does not contain any semantic annotation and requires extensive manual effort to build practical applications. Therefore, it cannot be exploited by other services due to absence of annotation standards, unless an IoT service provides raw sensor data with the necessary metadata (Desai et al., 2015).

In fact, semantic annotation of sensor data using a standard mechanism and vocabulary can provide interoperability between IoT vertical silos. Consequently, the Semantic Web community created and optimized standard ontologies for sensor observation, description, discovery and services via O&M,

SensorML, SOS and SSN. By integrating these annotated data and providing Semantic Web enabled messaging interface, a third party service can convert heterogeneous sensor observations to higher level abstractions (Patni et al., 2010)(Desai et al., 2015).

#### 2.2.5.6 Mediation

Another approach to implement semantic interoperability is mediation. That is, an intermediate component that sits between the different information models and performs the necessary transformations while keeping the meaning of the messages exchanged. For example, to facilitate semantic interoperability in the Operating Room (OR), especially between medical devices and information systems, it is necessary to mediate between communication partners that do not share a way of representing information. Hence, the Open Surgical Semantic Interoperability Engine (OSSIE) was developed, within the scope of the OR.NET project, with the objective of transforming messages that are exchanged between medical devices and/or IT systems into another form of representation while preserving the message semantics (B. Andersen et al., 2014).

#### 2.2.5.7 Linked services as a semantic interoperability layer

Linked data (Bizer et al., 2009) and linked services (Pedrinaci & Domingue, 2010) are approaches to interconnect the contents of the web in a machine interpretable format. Linked data offers the possibility for knowledge implicit in web documents to be made explicit in machine interpretable conceptual models (Resource Description Framework Schema - RDFS descriptions and ontologies) and allows sharing machine interpretable Knowledge Bases (KBs) across applications. Linked services complement this paradigm by providing the layer that processes linked data (Marco-Ruiz et al., 2016).

Some research exists to make webservices already implemented compliant with this paradigm. For example, Marco et al. (Marco-Ruiz et al., 2016) evolved web services into linked services to facilitate their publication, discovery and interoperability. The definitions of the webservices were linked to the models developed with linked data-based principles, to attach unambiguous semantics to the service components. All models were bound to SNOMED-CT and public ontologies (e.g. Dublin Core) to count on a “lingua franca” to explore them. As a result, the discovery and analysis of the services based on machine interpretable models was performed reasoning over the ontologies built (Marco-Ruiz et al., 2016).

#### 2.2.5.8 Semantic-driven architecture

There are also more comprehensive approaches to implement semantic interoperability, such as semantic-driven architectures. In this regard, Ford et al. consider that to ensure semantic interoperability between heterogeneous systems, an architecture is needed which includes a set of common ontologies between communicating parties. Such models are always implied by actors who exchange messages (otherwise communication is impossible), but in such an architecture they are made explicit (Ford et al., 2015).

For example, the architecture proposed by Martínez-Costa et al. is organized in five layers and spans from heterogeneous data repositories to homogeneous and semantically explicit representations (Martínez-Costa et al., 2014). Its first layer (structure heterogeneous data) comprises structured clinical data, which may be physically stored within an EHR repository and accessed via an interface conforming to some standard like HL7 CDA, openEHR, EN ISO 13606, or to a proprietary database schema. In the second layer (semantic mapping) semantic content patterns are introduced to bridge between structured data and their semantic representation. These patterns describe recurring information structures and provide a particular view on the underlying model of meaning, tailored to the needs of particular use cases, preventing users from a deep knowledge of the underlying ontology formalisms. The third layer (semantic mediator) is constituted by a set of ontologies which formalize clinical data meaning. These are an information entity ontology and a medical domain ontology, constrained by means of canonical categorizations and relations provided by a top-level ontology. The fourth layer (virtual homogeneous data) provides a homogeneous view on clinical data extracted from heterogeneous systems. Data are expressed at different detail levels but can be accessed homogeneously thanks to the underlying ontology-based annotations. Finally, the fifth layer (application) entails the clinical systems and services with different information needs. Each case will require data with different detail and precision, and not all the data retrieved might have the same trust level, which must be explicit.

Specifically regarding IoT, Desai et al. consider that although the utilization of standards provides the integration of Semantic Web with sensor applications, the interoperability challenges on IoT is far from being solved and a semantic IoT architecture is required to provide interoperability between connected IoT systems. Such an architecture should support multiple IoT protocols and severe resource and energy constrains (Desai et al., 2015).

Consequently, they proposed (Desai et al., 2015) the concept of Semantic Gateway as Service (SGS) as a bridge between sink nodes and IoT services. In the architecture proposed, the gateway acts as the center of data communication between the physical world and the Cloud. This architecture can be categorized as a Semantic Service Oriented Architecture (SSOA) for IoT systems, as it fulfills technical requirements such as service-oriented architecture, standard based design, and semantic-based computing leveraging application agents to autonomously interpret sensor data and interact mutually (Desai et al., 2015).

Architectures using ontologies can be found at the bottom level of the IoT stack. For example, the A3ME (Herzog & Buchmann, 2012) proposes a generic middleware where devices are represented by agents. By doing so, it enables ad-hoc device discovery, semantic description exchange and basic interactions between the devices. Another example is the approach of Kiljander et al. (Kiljander, D'elia, Morandi, Hyttinen, Takalo-Mattila, Ylisaukko-Oja, Soininen, & Cinotti, 2014), which is also an interoperability architecture for the sensors layer. This architecture is organized via semantic brokers and conforms to the Architectural Reference Model (ARM) (Bassi et al., n.d.), developed within the European Lighthouse

Integrated Project IoT-A (IoT European Research Cluster, 2014) (Ganzha et al., 2017).

## **PART II – Material and methods**

*“Doing good research means that we do not jump to conclusions but carefully find sufficient and appropriate sources of data, properly record, analyze, and interpret that data, draw well-founded conclusions based on the evidence, and present the findings in an acceptable way.”*

(Oates, 2006)

(page intentionally left in blank)



### 3 Research organization

In science, as well as in many circumstances in life, method is everything. The use of a systematic method is the soul of research, and as important as results is the way they are obtained. Without method, planning and management are not possible. There is no beginning nor end, we cannot tell where we are, where are we going nor when will we finish. Furthermore, without method we cannot assess the correctness and completeness of our conclusions, and so the work done becomes vulnerable, if not useless. Moreover, without method we cannot repeat the work in different contexts, which renders impossible the generalization of the conclusions. Finally, without method it is not possible to identify better ways to achieve the same results. In synthesis, without method, progress is a matter of luck. Therefore, this section is dedicated to present the method followed during our research.

#### 3.1 Research process

In his book entitled “Researching Information Systems and Computing” (Oates, 2006), Oates provides an introduction to those researching in the information systems and computing disciplines. He presents the type of research questions and approaches typical of these fields and discusses the analysis and evaluation of research projects in those areas. Particularly, he discusses the research process in detail and presents the model depicted in the following figure.

Figure 5: Model of the research process

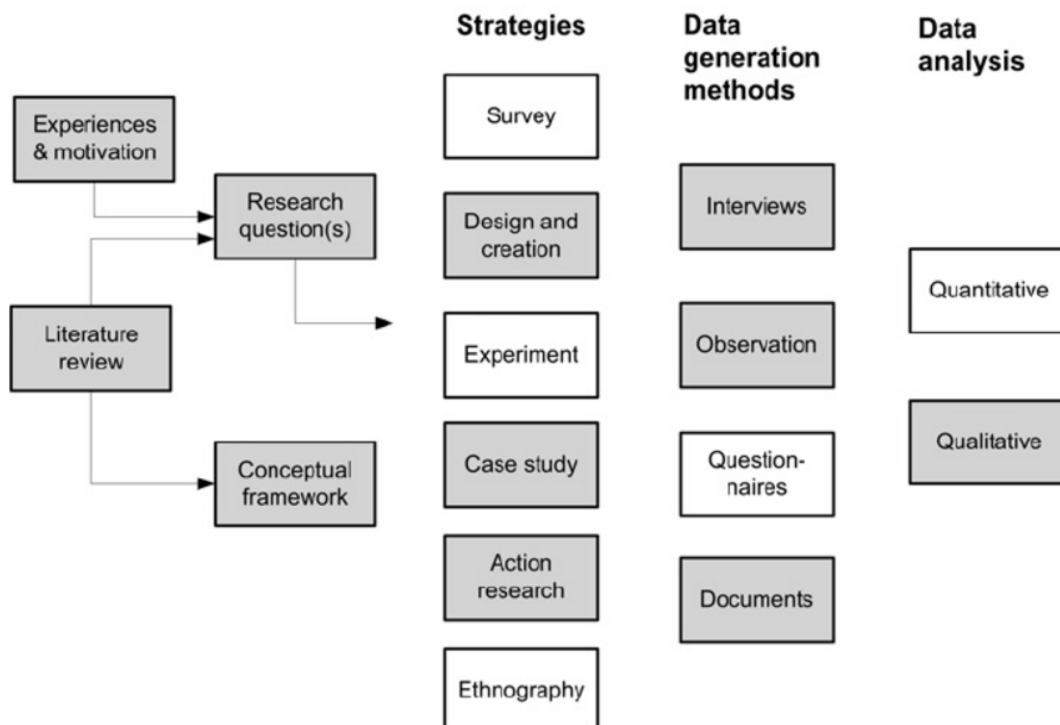

Source: Oates, 2006

According to this model, while the experience and motivation of the researcher are its main drivers, it is during the literature review that he discovers, in detail, what has been done before, as well as what remains to be addressed in his field of choice. It is, therefore, while performing these two activities that research questions emerge. Then, a research strategy is chosen. In its essence, this strategy is the approach that will be used to answer the research question, and typically one research question leads to one research strategy. Afterwards, the data generation methods are selected. Although some of the methods are commonly associated to a specific strategy (e.g. observations and experiments), one strategy can use more than one method (method triangulation) to generate the necessary data, which would improve the quality of the research but also, very likely, require more time and resources. Finally, the data generated can be analyzed quantitatively or qualitatively.

### **3.2 Research questions, hypothesis and objectives**

We have seen that interagency information exchange is essential for increasing the efficiency and effectiveness of public organizations. We have also seen that there is no exchange of information if the organizations involved are not interoperable with each other, and that interoperability is enabled in multiple different layers. Finally, we have seen that, to properly manage the development of organizations' interoperability we need instruments to assess it. Therefore, considering the specific case of the development of organizations' semantic interoperability, in the context of initiatives that adopt a common model to exchange information, the main question this research aims to answer is:

*RQ: Is it possible to develop an artefact to assess the semantic interoperability of an organization that is willing to exchange information with other organizations by using a common information model?*

We have also seen that this artefact is needed for several reasons. It is needed to enable the definition of the present and future (desired) situations of semantic interoperability. It is also needed to support the identification, prioritization, monitoring and control of the actions deemed necessary to achieve the objectives established, and it is needed to support the justification and comparison of alternative initiatives. Consequently, the required artefact must be able not only to assess the performance of an organization in what concerns its semantic interoperability, but also what is possible to achieve with it – that is, its relevance towards the organizations' strategic objectives. And so, we have broken down our main research question into the following two:

*RQ1: Is it possible to develop an artefact to assess the semantic interoperability performance of an organization that is willing to exchange information with other organizations by using a common information model?*

*RQ2: Is it possible to develop an artefact to assess the relevance of the semantic interoperability performance of an organization that is willing to exchange*

*information with other organizations by using a common information model?*

The scientific method implies establishing hypothesis that will be confirmed or rejected throughout the study, and that these hypotheses are derived from the research questions defined. Therefore, the hypotheses of this research are the following:

*H1: It is possible to develop an artefact to assess the semantic interoperability performance of an organization that is willing to exchange information with other organizations by using a common information model.*

*H2: It is possible to develop an artefact to assess the relevance of the semantic interoperability performance of an organization that is willing to exchange information with other organizations by using a common information model.*

Also, according to the scientific method, the research objectives are a direct consequence of the research hypothesis, and so the objectives of this research are the following:

*Develop an artefact to*

*O1: assess the semantic interoperability performance of an organization that is willing to exchange information with other organizations by using a common information model.*

*O2: assess the relevance of the semantic interoperability performance of an organization that is willing to exchange information with other organizations by using a common information model.*

### **3.3 Research strategy**

In this research we followed the Design Science Research (DSR) strategy. This is a method that establishes and operationalizes research when the desired goal is an artifact or a recommendation (Dresch et al., 2015). In DSR, the researcher answers questions relevant to human problems via the creation of innovative artifacts, and thus contributes new knowledge to the body of scientific evidence, where the designed artifacts are both useful and fundamental in understanding that problem (Hevner & Chatterjee, 2010).

The DSR is therefore focused in problem solving (March & Storey, 2008). Moreover, the artifacts created in DSR must be assessed against criteria of value or utility (Dresch et al., 2015) and are demonstrated to improve manager's capability to "change existing situations into preferred ones" (Simon, 1996). One of DSRs main characteristics is that it is oriented to obtain a satisfactory solution, even if it is not optimal. However, any solution should be generalizable for a specific class of problems (Sein, 2011; Vaishnavi et al., 2017; van Aken, 2004, 2005) so that other researchers and practitioners can use the generated

knowledge.

**Figure 6:** Design Science Research Criteria

**Source:** Hevner, 2004

1. <i>Design as artifact</i>	<ul style="list-style-type: none"><li>• Research developed with the <i>design science research</i> method must produce viable artifacts in the form of a construct, model, method or instantiation</li></ul>
2. Problem relevance	<ul style="list-style-type: none"><li>• The purpose of design science research is to develop solutions to solve important and relevant problems for organizations</li></ul>
3. <i>Design Evaluation</i>	<ul style="list-style-type: none"><li>• The utility, quality and efficacy of the artifact must be rigorously demonstrated via well-executed evaluation methods</li></ul>
4. Research Contribution	<ul style="list-style-type: none"><li>• Research conducted by the design science research method must provide clear and verifiable contributions in the specific areas of the developed artifacts and present clear grounding on the foundations of design and/or design methodologies</li></ul>
5. Research rigor	<ul style="list-style-type: none"><li>• Research should be based on an application of rigorous methods in both the construction and the evaluation of artifacts</li></ul>
6. <i>Design as a research process</i>	<ul style="list-style-type: none"><li>• The search for an effective artifact requires the use of means that are available to achieve the desired purposes, while satisfying the laws governing the environment in which the problem is being studied</li></ul>
7. Communication of the research	<ul style="list-style-type: none"><li>• Research conducted by design science research must be presented to both an audience that is more technology-oriented and one that is more management-oriented</li></ul>

Consequently, to support DSR the seven criteria depicted in the figure above were defined (et al. Hevner & Hevner, 2004). According to these criteria, in DSR a new artifact must be created, and it must target a

specific problem. Its utility must be explained, and the artifact must be evaluated. The contributions of the artifact must be clarified for professionals and academics to increase knowledge in the area. The artifact must be suitable for its proposed usage and satisfy the criteria for its development. Research to understand the problem and obtain potential problem-solving methods is necessary, and the research results should be communicated to interested parties.

Design Science Research must also provide appropriate theoretical and practical contributions, for which various requirements must be met (March & Storey, 2008). First, the problem to solve must be relevant. Second, the researcher must demonstrate the lack of suitable methods, or better solutions, to solve the problem. Third, a new artifact to solve the problem must be developed, which should be validated in terms of its utility and viability to demonstrate its practical and academic validity. Fourth, the research must ensure that it contributes to advance general knowledge and to improve practical situations in organizations. Finally, researchers must explain what was constructed and the implication of the results for the practical field.

There are various methods proposed for conducting Design Science Research, and most of them were originated in the field of Information Systems. In the following figure we can see the evolution of these methods over time. A thorough review and comparison of each of these methods was already developed by Dresch (Dresch et al., 2015). To conduct our research, we followed the method proposed by Peffers et al. (Peffers et al., 2006), since it is focused in the core of Design Science Research and is simpler than most recent ones, without missing important aspects. In addition, the model proposed by Baskerville (Baskerville et al., 2009) does not include an evaluation phase, which we consider to be essential in this strategy.

**Figure 7:** Design Science Research methods evolution

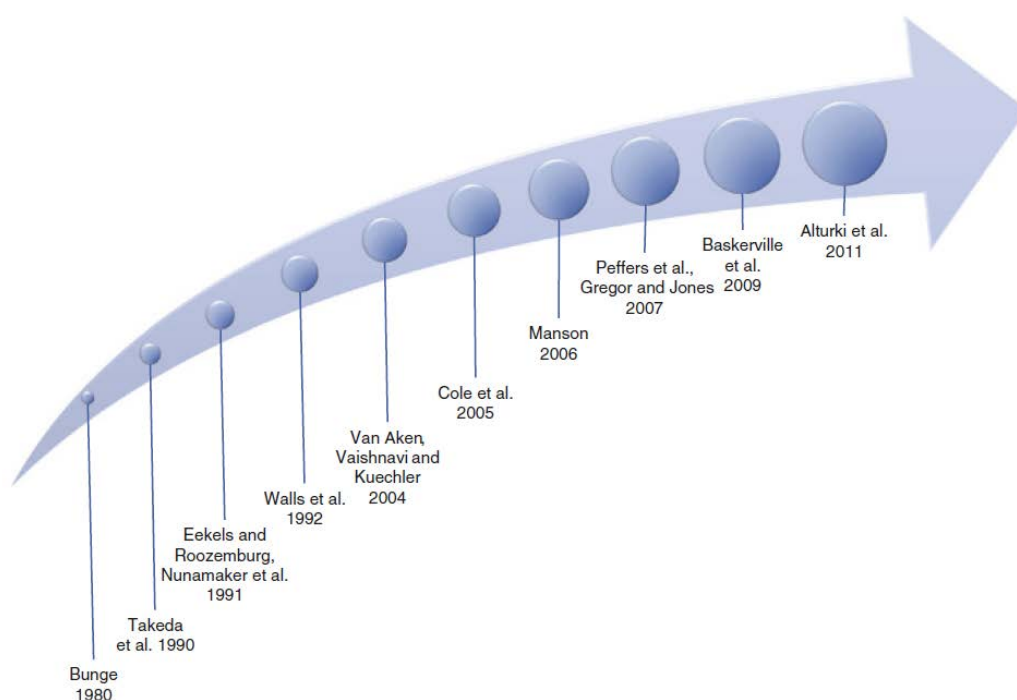

The method proposed by Peffers (Peffers et al., 2006) comprises six phases, as depicted in the following figure. In the “problem identification” phase, the specific research problem must be defined, and the value of the solution must be justified. Then, in the “definition of the expected results” phase, the objectives of the solution, which can be defined quantitatively or qualitatively, are inferred from the problem definition. This phase implies knowledge of potential solutions and results. In the “design and development” phase artifacts are created, which implies the definition of their required functionalities and architecture. In the “demonstration” phase, the efficacy of the artifact to solve the problem is demonstrated, which can involve, for example, a case study, a simulation or an experimentation. Then, in the “evaluation” phase, the artifact is assessed on how well it supports a solution to the problem specified. The base for comparison are the objectives defined earlier. Finally, in the “communication” phase, the problem and its relevance, the artifact utility and novelty, rigor and effectiveness are disseminated to researchers and other relevant audiences.

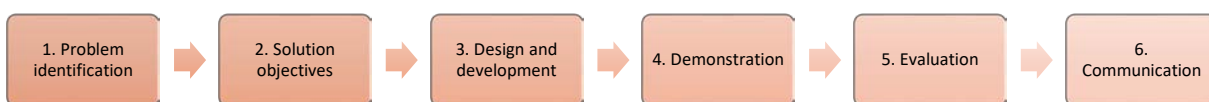

**Source:** Authors based on Peffers, 2006

Figure 8: Main activities of the Design Science Research Method (DSRM)

### 3.3.1 Problem identification

The problem this research tackles is the lack of an adequate artefact to assess the semantic interoperability of an organization that is willing to exchange information with other organizations by using a common information model. Information exchange among governmental agencies is increasingly pointed out as an essential practice in many sectors with high political, social and economic impact, such as security and health. Therefore, it is important to have the right artefacts available for developing the semantic interoperability of organizations, and these artefacts must help in defining and supporting the management of sustainable initiatives, while taking into consideration that, often, such initiatives are large-scale, complex and dynamic. Particularly, there is the need for an artefact that can support the determination of the present, desirable and possible semantic interoperability performance, as well as its relevance, for each of these dimensions, regarding the strategic objectives defined.

Without such an artefact, improving the performance of governmental agencies, by means of exchanging

information, cannot be managed and so, achieving the desired political, social economic desired impacts will become harder, if not impossible. Evermore governmental resources are scarce, be it human or material. Simultaneously, the challenges faced by governments are increasingly diverse, dynamic and demanding. Consequently, it has become common to hear the expression “do more with less”, which means that we need to take the most out of the resources available and that we cannot afford to waste them with wrong decisions, which implies that governmental decisions must be more efficient and effective. Therefore, the goal of the artefact we envisage with this research is to support the governmental decision-making processes regarding the development of initiatives for improving the agencies’ semantic interoperability, namely by enabling governments to prioritize the right initiatives - those that provide more benefits – in a more efficient way.

Presently, there are very few solutions for this problem, and those which exist have various limitations. Some of the solutions are domain specific (Feng & Flewelling, 2004; Paul & Ghosh, 2008), be it a technical or a functional domain. Others are too generic (European Commission, 2016; Guédria et al., 2008, 2009), and others fall short when it comes to enable understating how much can semantic interoperability be developed and why (Dolin, R. H., Alschuler, 2011; Rezaei, R., Chiew, T., Lee, 2013; Yahia et al., 2012). Maybe for these reasons, most of these solutions do not seem to be used in practice, and those which are, do not seem to address the problem with the necessary breadth and depth.

### 3.3.2 Objectives definition

The artefact we aim to develop has the following objectives, organized into three distinct categories – effectiveness, efficiency and quality.

#### 3.3.2.1 Effectiveness objectives

O1 – to enable determining the present semantic interoperability performance of an organization

O2 – to enable defining the desired semantic interoperability performance of an organization

O3 – to enable defining the possible semantic interoperability performance of an organization

O4 – to enable determining the impact of the present semantic interoperability performance of an organization

O5 – to enable defining the impact of the desired semantic interoperability performance of an organization

O6 – to enable defining the impact of the possible semantic interoperability performance of an organization

### 3.3.2.2 Efficiency objectives

O7 – to be appropriate for large-scale initiatives

O8 – to be cost-effective

O9 – to enable consensus among the organizations involved

### 3.3.2.3 Quality objectives

O10 – to be easy to use

O11 – to be independent from the specific domain and case of application

O12 – to adapt to organizational and context changes

## 3.3.3 Design and development

Conceptually, the artefact we aim to develop is composed by two main parts. One aiming the assessment of the semantic interoperability performance and another aiming the determination of its relevance. To achieve the objectives of the first part, we have developed a set of indicators that can be used to assess the present, desired and possible semantic interoperability performance of an organization, in relation to the other organizations involved in the information exchange initiative and based on the common model used to exchange information among them. Then, to achieve the objectives of the second part, we have developed a way to determine the relevance of the information to be exchanged regarding a set of strategic objectives that the information exchange initiative aims to contribute to.

The element which brings both parts together is the common information model, since both are based on it. To obtain the necessary data to calculate the indicators and the relevance of the situation we have also developed a questionnaire, to be filled in by domain experts with technical and functional backgrounds. Finally, to help in calculating many of the components of the framework, we have developed a software application.

On the one hand, indicators are a suitable tool for assessing semantic interoperability, since they are the qualitative and/or quantitative information on an examined phenomenon which enables the analysis of its evolution, checking if quality targets are met, driving actions and decisions (UNI 11097, 2013). On the other hand, semantic interoperability is one of the characteristics of the process to exchange information among organizations. Therefore, the evaluation of the performance of semantic interoperability cannot be disconnected from the evaluation of the performance of information exchange, and so falls in the context of process performance assessment. Consequently, to design and develop the indicators, we have used a specific methodology (Franceschini et al., 2007) for defining and testing process performance indicators, which comprises the five activities depicted in the following figure.



To exemplify the indicators and the determination of the semantic interoperability performance, we have defined an information sharing scenario, which is depicted in the following figure and is described in detail in appendix 1. This scenario comprises the typical elements involved in the determination of the information exchange performance and a series of situations that allow exemplifying the usage of all indicators defined. This scenario is not representative of any real situation; on the contrary, it is quite small (the information model used has 100 times less information elements than the case we use to demonstrate our artefact. Moreover, in the scenario there are only 3 organizations involved, four times less the ones involved in the project used for the demonstration of the framework, and over 100 times less the ones involved at the wider European level, thus allowing us to see that, without an artefact like the one we propose, that supports the determination of the performance and relevance of the semantic interoperability in a semi-automatic way in large-scale initiatives, it would be extremely hard, if not impossible, to do it manually.

**Figure 9:** Information sharing scenario

Source: Authors

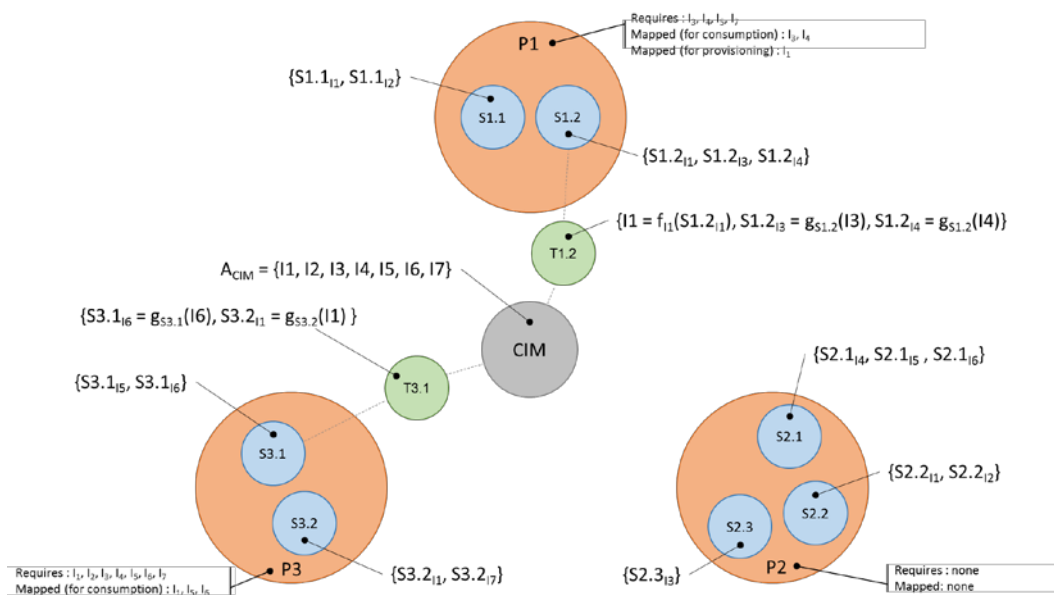

The central aspect of the methodology used to define the indicators is the process which performance will be measured. According to the ISO 9000:2000 standard (ISO, 2000), a process is “an integrated system of activities that uses resources to transform inputs into outputs”. Therefore, we have defined a generic process for information exchange among organizations, where semantic interoperability components are put into evidence. As such, the assessment of semantic interoperability is aligned with the overall assessment of the information exchange process and, in future work, other aspects of information exchange, such as the technical, legal and organizational interoperability can also be defined in this process and measured in an analogous way, and hence enable a complete assessment of the performance of information exchange among different organizations.

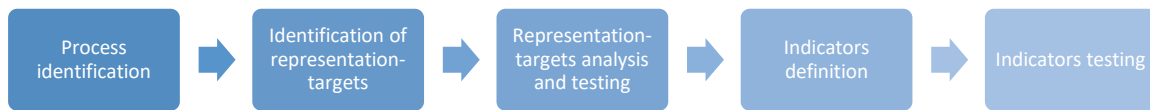

**Source:** Authors based on Franceschini, 2007

**Figure 10:** Process used to define and test the indicators

The relevance of the semantic interoperability performance is determined based on the relevance of the information elements to be exchanged regarding the strategic objectives defined. However, this relevance varies from stakeholder to stakeholder and, therefore, it is important to achieve their consensus in this matter. In this context, we use the questionnaire to obtain the opinion of each of the stakeholders and then use the Weighted Sum Model (WSM) (C. Fishburn, 1967) to calculate the relevance of each of the information elements considered. Then, we use the Delphi method (Linstone, Harold A. Turoff, 1975) to reach the consensus of the stakeholders.

Multi-Criteria Decision Methods (MCDM) aim to try to determine, via various procedures, a ranking of the decision alternatives that is optimal concerning several criteria. However, there are various possibilities, among the most commonly used MCDM (Chen et al., 1992; Hwang, 1987) such as the Weighted Sum Model (WSM), the Analytic Hierarchy Process (AHP), the revised AHP, the Weighted Product Model (WPM), the ELECTRE and TOPSIS. Within these, the WSM (C. Fishburn, 1967) is probably the mostly used (Triantaphyllou, 2000). It is appropriate for single dimensional cases (where all units are the same) and lies on the assumption (verified, in our case) that the total value of each alternative is equal to the sum of the products given; therefore, this was our choice to determine the relevance of the various information elements.

Table 1: Common problem properties which justify employing the Delphi method

<i>Common problem properties</i>	
1	The problem does not lend itself to precise analytical techniques but can benefit from subjective judgements on a collective basis;
2	The individuals needed to contribute to the examination of a broad or complex problem have no history of adequate communication and may represent diverse backgrounds concerning experience or expertise;
3	More individuals are needed that can effectively interact in a face-to-face exchange;
4	Time and cost make frequent group meetings infeasible;
5	The efficiency of face-to-face meetings can be increased by a supplemental group

**Source:** Authors based on Linstone, Harold A. Turoff, 1975

- communication process;
- 6 Disagreements among individuals are so severe or politically unpalatable that the communication process must be refereed and/or anonymity assured;
- 7 The heterogeneity of the participants must be preserved to assure the validity of the results.

Regarding the remainder MCDMs, the WPM was developed to overcome some of WSM's weaknesses by eliminating any units of measure (Triantaphyllou, 2000). However, since this is not an issue in our case, the WPM would introduce complexity unnecessarily; and so, we decided not to use it. The AHP is becoming increasingly popular and the Revised AHP is more consistent than the AHP (Triantaphyllou, 2000); however, since our criteria are not hierarchical, none of these methods is applicable; hence, we have also not decided to use them. Finally, considering the large amount of decision alternatives expected - information models of large-scale information exchange initiatives typically involve large information models - methods based on a pairwise comparison (which demand high user intervention) such as the ELECTRE and TOPSIS are not feasible because respondent fatigue limits the number of alternatives that can be ranked (Bradburn et al., 2004); hence, we have also decided not to use any of them.

The Delphi method is used for structuring a group communication process, so that it is effective in allowing a group of individuals, as a whole, to deal with a complex problem (Linstone, Harold A. Turoff, 1975). More specifically, it is appropriate for situations that, like large-scale interagency information exchange initiatives, face the problems indicated in the table above. In practice, it consists of collecting information, usually in the form of a questionnaire, from a set of experts, processing the results, iterating with experts as many times as necessary, providing the consolidated results and allowing the experts to change their evaluations (information provided on a certain topic), until consensus is reached.

The common information model used to exchange information is a key component of our artefact, and we should not confuse an information model with a data model, especially since often these concepts are used interchangeably in the literature. The main purpose of an Information Model (IM) (Pras & Schoenwaelder, 2003) is to model managed objects at a conceptual level, independent of any specific implementations. Data Models (DM) (Pras & Schoenwaelder, 2003), on the other hand, are defined at a lower level of abstraction, include many details, and are intended for implementers. Consequently, multiple DMs can be derived from a single IM.

The baseline of the questionnaire is generic and is composed by three main parts. The first is the set information elements from the common model used to exchange them. The second is the set of organizational objectives to be achieved with the exchange of information, and the third is the set of options used to classify the relevance of each information element to each objective (relevance scale). To use the questionnaire, domain experts must be involved to instantiate each of these parts with specific domain elements. Then the questionnaire is made available electronically to them, which return it dully filled when ready. The questionnaire should be designed using common best-practices for questionnaires (Bradburn et al., 2004), such as ethical principles and closed-answer formats.

### 3.3.4 Demonstration and evaluation

The DSR foresees the demonstration that the artefacts developed can be effectively used to solve real problems (Tremblay et al., 2010). As such, it implies using the artefacts to solve one or more instances of the problem, while ensuring the resources involved have the necessary knowledge of how to use them (Peppers et al., 2007). Among the different ways that DSR foresees (Dresch et al., 2015) to demonstrate the artefacts, we chose the “Observational” form, which primary goal is to determine how they behave in a comprehensive manner and in a real environment (Hevner & Chatterjee, 2010) to ensure that they completely achieve their function (Pries-Heje & Baskerville, 2008). Consequently, we demonstrated our artefact in a real and relevant environment – the NIPIMAR project, for which we obtained the data and information access and usage permission that is provided in annex A. To evaluate the artefact, we made a qualitative comparison between the results obtained during the demonstration and the objectives defined.

The NIPIMAR project aims to develop integrated maritime surveillance and marine environment monitoring in Portugal, by enhancing the exchange of relevant information among all national and international stakeholders through a common information sharing system, which entails a common information model. This large-scale IIS initiative is based on and contributes to the CISE. It involves over 20 national agencies, representing the CISE seven user communities (i.e. General Law Enforcement, Customs, Marine Environment, Maritime Safety and Security, Defence, Fisheries Control and Border Control) (European Commission, 2010e), has started in 2009 and will be concluded in 2020. Its implementation follows an iterative and incremental approach and entails many other smaller projects, some of which funded by different financial instruments.

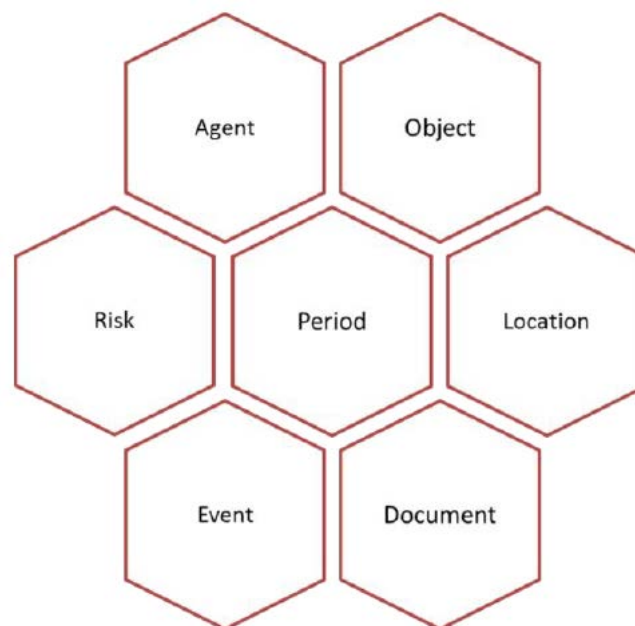

**Figure 11:** CISE common information model - Main information entities

The common information model used in our research was the latest version of the CISE common information model, developed during the CoopP project (Finnish Border Guard, 2014), which is also used in the NIPIMAR project. It consists of 18 entities, 7 main and 11 complimentary, with about 700 attributes. The information entities are defined in natural language and specified in Unified Modelling Language (UML) (Object Management Group, 2015). It comprises several specific features to accommodate crosscutting concerns such as auditing, security and data reliability and validity. The model represents over 50% of the information needs identified for the development of the CISE, and over 64% of its definitions are based on existing definitions from 34 related standards, systems and initiatives. The model has been defined using classes, attributes, associations and enumerations, with broad definitions and examples.

**Source:** Finnish Border Guard, 2014

**Source:** Finnish Border Guard, 2014

The model comprises the seven information entities, essential to maritime surveillance information exchange, depicted in the figure above. In addition, eleven other information entities were defined to increase the overall expressiveness of the data model and to support specific features to accommodate crosscutting concerns such as auditing, security, data reliability, and validity. These entities are depicted in the following figure.

Figure 12: CISE common information model - Complimentary information entities

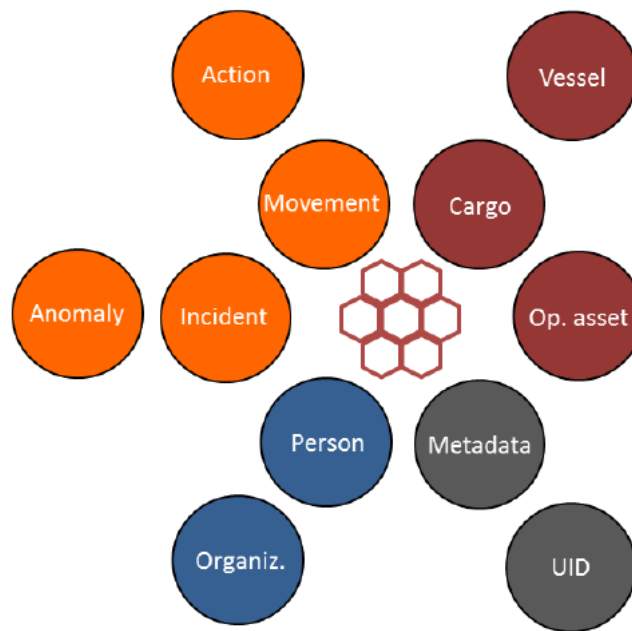

**Source:** Finnish Border Guard, 2014

Finally, the strategic objectives we use to determine the relevance of each of the information elements were the mitigation of the risks defined during the CoopP project (Finnish Border Guard, 2014). During this project, one of the activities was to determine the cost-benefit of using the CISE for the exchange of maritime surveillance information among the over 400 agencies involved in this domain throughout Europe (European Commission, 2014b).

To do so, experts considered seven different risks and, based on a series of specific use cases, calculated the cost-benefit of using the CISE to support addressing each of them. These risks were Illegal, Unregulated and Unreported (IUU) fishing, illegal oil spills and discharging, counterfeit goods, maritime accidents, drug trafficking, irregular migration and piracy. The calculation of the cost-benefit was done in three different scenarios, the minimum (pessimistic), the conservative and the maximum (optimistic). The benefits are evaluated in terms of cost-effectiveness with respect to compared to the annual operating costs of maritime surveillance in Europe.

The results were that the Total Cost of Ownership (TCO) of the CISE was estimated between EUR 77.9 and EUR 126.1 million, aggregated over a 10-year period. It combines both one-off Capital Investment Expenditure (CapEx) and annual Operating Expenditure (OpEx), and includes investment, operating, and other non-IT costs. The benefits estimated range between 176 (pessimistic) and 423 (optimistic) million euros over a ten-year period as well, and are depicted in the following table. The values of the benefits in the conservative scenario were also used, in this research, to determine the relative importance of each of the risks.

Table 2: Scenarios total estimated economic benefit (M €) per risk considered

	<b>IUU Fishing</b>	<b>Illegal oil spills and discharges</b>	<b>Counterfeit goods</b>	<b>Maritime accidents</b>	<b>Drug trafficking</b>	<b>Irregular migration</b>	<b>Piracy</b>	<b>Total benefits</b>
<b>Minimum scenario</b>	34	26	25	17	25	25	23	176
<b>Conservative scenario</b>	<b>55</b>	<b>42</b>	<b>40</b>	<b>28</b>	<b>40</b>	<b>40</b>	<b>36</b>	282
<b>Maximum scenario</b>	82	63	61	42	61	61	54	423

**Source:** Authors based on Finnish Border Guard, 2014



## **PART III – Results and analysis**

*“Responsible information sharing is a journey, not a destination”*

(Office of the Director of National Intelligence, 2015)

(page intentionally left in blank)

## 4 Conceptual model

### 4.1 Overview

The iShare framework is an instrument that can be used by organizations, willing to exchange information, to assess their semantic interoperability. The assessment is done in two different planes. The first one is the plane of performance, which is measured based on data collected from the organizations and their information systems. The second one is the plane of relevance, which is measured based on the opinion of experts in the domain of application. By assessing their semantic interoperability using the iShare framework, organizations should be able to gain a better understanding of their present situation and to define the situation they wish and the plans to achieve it.

#### 4.1.1 Why use it?

The goal of the iShare framework is to foster information sharing among organizations, and it does so by acting in three essential aspects. These aspects, depicted in the following figure, are Awareness, Cost-effectiveness and Reuse, and they are interdependent. That is, improving each of them will also contribute to improve the remainder, although optimal results can only be achieved if all of them are addressed specifically.

Figure 13: How the iShare framework fosters information sharing

**Source:** Author

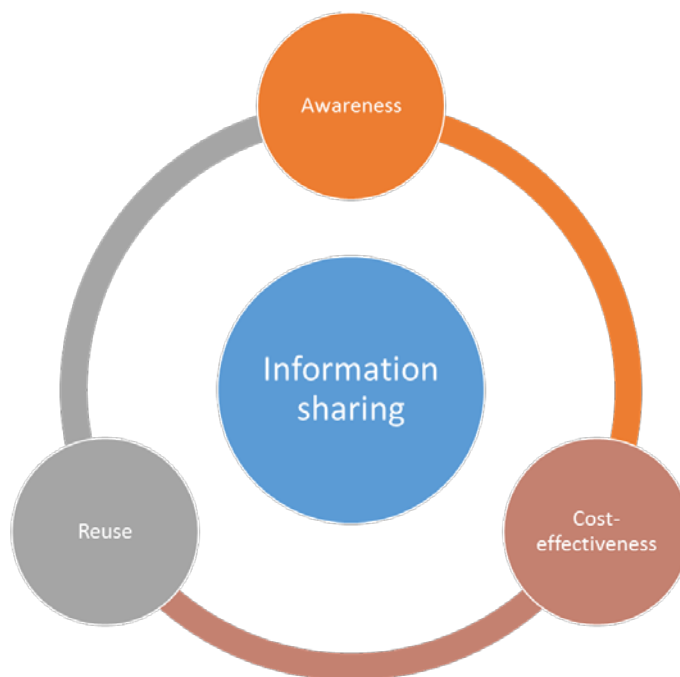

#### 4.1.1.1 Awareness

If we do not know that a certain situation can be improved, it will only change in a positive way by coincidence. Therefore, if we wish to develop further the information exchange among organizations, the first and foremost thing to do is to raise the awareness on the situation, identifying what must be changed and why.

Unfortunately, in practice, we realize that often such awareness is wrong or does not exist. From experience, it is quite common to find organizations that do not know which information is available in other organizations (even from the same country) and how it could improve their performance. Likewise, some organizations often do not know the value of some information they hold to other organizations. Last, but not least, some organizations have usually been so keen on collecting information that they are not aware of how inefficient their approach has (or is going to) become. For example, we are referring to organizations that develop technologies to collect data (e.g. radar systems) when the information that these technologies will collect is already being collected by other organizations, or organizations that exchange information without using an information model commonly defined among the different organizations that usually deal with and exchange the same information.

Exchanging information with other organizations, like many other activities, entails a cost and a benefit that must be well understood, pondered, and took into planning, if we wish those initiatives to be cost-effective. Additionally, a poor understanding of the benefits also hampers the expectations of those involved and may well prevent further necessary developments if those are defrauded.

Very often we see organizations involved in information exchange initiatives which objective is to develop at once all technological capabilities necessary to share any piece of information considered

relevant, without taking into consideration which information is indeed available to be shared (from a technical point of view) and what is its intrinsic value. Consequently, these organizations will spend time and money developing useless capabilities that will still have to be maintained, hence will also imply costs over time without a foreseeable or clear benefit.

Moreover, as soon as these organizations realize that the capabilities developed are not performing as expected, because they are not receiving the information they need, they will engage in alternative activities to obtain that information in a more effective way (probably by developing their own capabilities to collect it). Consequently, they will avoid any other information sharing initiatives, which to begin with typically comprise many other complexities beyond technical, and thus will most likely contributing to the duplication of resources and its dire consequences.

The way the iShare framework helps on identifying what must be changed and why is twofold, as depicted in Figure 14. On the one hand, the framework helps to determine the semantic interoperability performance of an organization. On the other hand, it helps to determine how relevant that performance is. By knowing these two elements, an organization becomes more aware of its situation and can make more informed decisions in this matter.

Figure 14: Developing awareness on semantic interoperability

Source: Author



The semantic interoperability performance of an organization can be determined by the difference between how much semantic interoperability is already implemented and how much it is required. While the latter can be established considering the information required by the organization which is available in

other organizations, and by the information available at the organization that is required by other organizations, the first can be determined based on the semantic developments made to transfer that information among the information systems involved.

By determining the semantic interoperability performance of an organization, we find out what must be changed and develop the ability to compare the semantic interoperability performance of organizations, projects and programs. On the one hand, the comparison of the semantic interoperability of organizations can be used to support the development of policies and programs for information sharing. For example, such knowledge can be used to define what should be done to improve the present situation, by whom and why. On the other hand, the comparison of projects and programs semantic interoperability objectives can be used to support the development of such initiatives. For example, as criteria for awarding grants.

Information is usually exchanged with a purpose; therefore, when some information is not being exchanged, when it should be, something is being hindered. Therefore, a low performance on certain objectives of an organization can well be a good indicator that more information exchange is needed. Therefore, to understand the relevance of the semantic interoperability of an organization, we need to understand how the information inherent to that interoperability contributes to the objectives of the organization.

In practice, organizations work together to achieve certain objectives. For example, it is common to see in countries (and across countries as well) several organizations collaborating for achieving the common goal of maritime safety (i.a. navy, coast guard, air force, border guard). So, the performance of the country to achieve certain national goals is determined by the individual performance of the organizations that collaborate for that purpose. Likewise, the impact of the individual performance of each organization enables us to understand the overall impact of the organizations involved to achieve a certain objective.

#### 4.1.1.2 Cost-effectiveness

The main reasons why the iShare framework supports the development of information sharing in a cost-effective way is because it is focused in the delivery of the right information in the right time to the right organization, as depicted in Figure 15. The initiatives that deliver information like this (just enough information) take less time and risks and can lead to bigger benefits in the short term.

Figure 15: Developing cost-effective interoperability

Source: Author

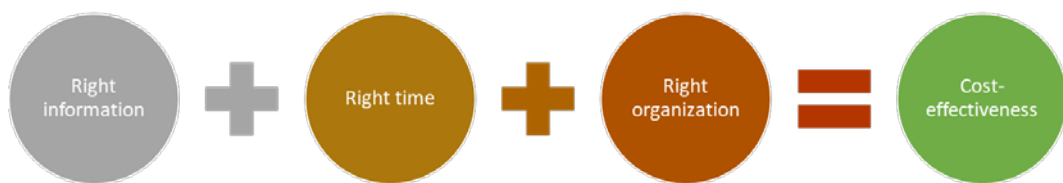

Delivering the right information means that the technological capabilities that are to be developed are those strictly necessary to enable sharing the information that is available to be shared and that can be consumed. This will avoid spending time and money in developing useless technological capabilities. Therefore, delivering the right information depends on the analysis of exactly which information is available in each organization that is required by others and of the capability of the organizations to consume the information they require.

However, even though plenty of information may be available, their relative importance is often not the same. That is, not all the information available will have the same potential to increase the organizations' performance. Therefore, why spend time and money in developing technological capabilities to share information which benefit is not so high, and why take the risks inherent to increasing the complexity of the projects by doing that? For these reasons, the implementation of the technological capabilities necessary to share information should be deferred in time; that is, delivered on the right time.

The iShare framework provides us with the necessary tools to devise multiple initiatives, which deliver just enough information, rather than one single initiative to deliver all the possible information to the organizations that really need more that information and that can actually use it. Therefore, these multiple initiatives can be shorter in time, cost less money and entail fewer risks, since its complexity will be lower.

Moreover, if these initiatives take into consideration the relevance of the information to be shared, it will

be possible to start sharing the more relevant information in the earlier initiatives, leaving the value less relevant information to the latest initiatives. This, being the opposite of what is often done, will have the effect of motivating the stakeholders from the earlier moments, since they will have better value for money.

#### 4.1.1.3 Reuse

Last, but not least, the iShare framework also fosters information sharing because its approach promotes the reuse of the technological solutions developed, and the main reason for this is that it is based on a Common Information Model (CIM); that is, an information model used by all organizations involved in the initiative to share the information agreed upon among themselves.

Figure 16: Developing reusable interoperability

Source: Author



The more the CIM is used by organizations to share information among themselves, the better. The reason is simple, once the semantic interoperability between the organizations' information systems and the CIM is established, no other semantic developments shall be necessary, and only the configuration of the technological capabilities to share information will be required for the organization to send information to other organizations or to receive information from them. To this end, the CIM should be largely independent from any information model the organizations involved in the information sharing initiative might be using. Therefore, it means that their own information models (and systems) can evolve freely, without influencing the information sharing solution used.

On the contrary, when the information sharing solution was devised bilaterally, based on the organizations' systems information models and without using a CIM, those information models (and



systems) cannot evolve freely, without affecting the overall solution. In addition, when it becomes necessary to exchange the same information with another organization this will require specific developments from that organization, to adjust to the specific information models used in the information exchange solutions. Hence novel solutions will be created, to exchange the same information but with different organizations, that will have to be maintained throughout time, hence originating duplicated costs.

#### 4.1.2 When to use it?

The iShare framework is an instrument that allows capturing the state of the semantic interoperability of one or more organizations at a certain point in time. It provides the tools to evaluate that state and to support taking decisions regarding its evolution. When used periodically, the iShare framework also allows for monitoring how that state changes, hence to ascertain if its developments are according to the objectives defined. This will then enable the definition of adjustments, both in the objectives and in the actions to be taken, as necessary to succeed.

Since semantic interoperability is essential for information sharing, the iShare framework should be used in initiatives that involve it and where it is important to have this kind of knowledge and tools. Examples of where the iShare framework could be used are during the development of a strategy or a project for information exchange.

##### 4.1.2.1 [The agile process for improving semantic interoperability](#)

The iShare framework fits nicely an agile process for improving the semantic interoperability of one or more organizations. Such a process, depicted in Figure 17, should be iterative and incremental and composed by three major activities: 1) Assess, 2) Decide and 3) Improve. Like this, multiple initiatives to deliver “just enough information” can be delivered sequentially, with high value in the beginning that can increase the motivation and trust of the stakeholders in the initiative and among themselves.

Figure 17: Agile process for improving semantic interoperability

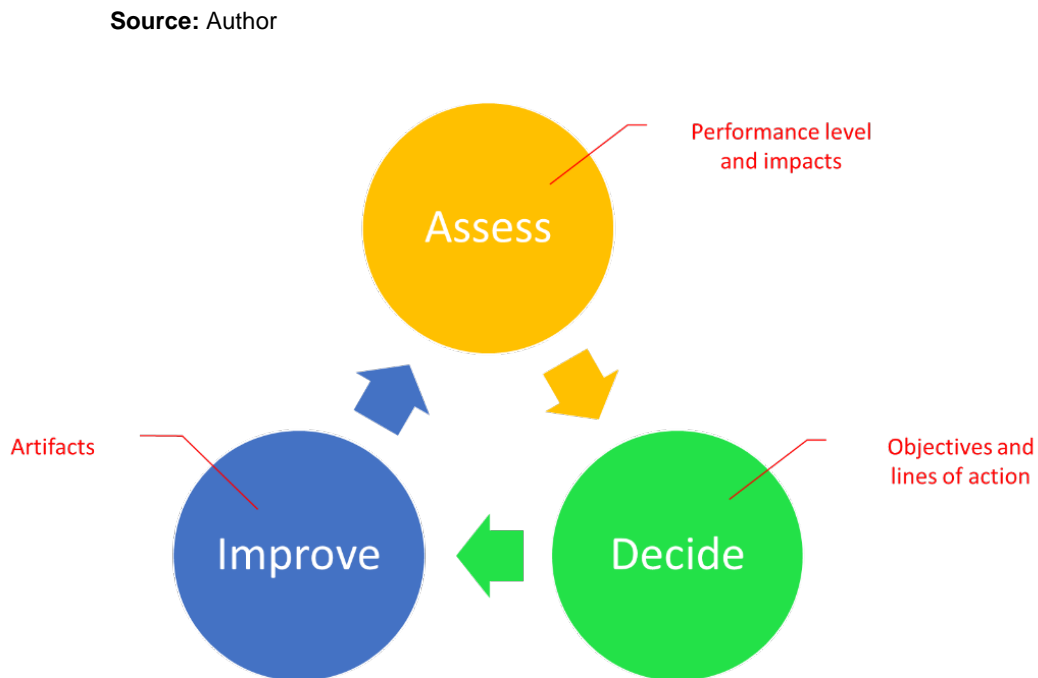

The purpose of the first activity (Assess) is to analyze the situation of the semantic interoperability of one or more organizations at a certain point in time. Based on this analysis, this activity will then focus on establishing the relevance of that situation. This activity is essential for the remainder, which cannot be developed without its results. During this activity, the iShare framework should be used to establish the semantic interoperability performance of each of the organizations under assessment. It should also be used to establish the relevance of that performance, considering the criteria defined for that purpose. By doing this, the iShare framework is contributing to develop the awareness of the situation, which, as already seen, is essential for the development of information sharing.

The purpose of the second activity (Decide) is, on the other hand, to define how the semantic interoperability should change. Consequently, the objectives must be defined and the actions that will

allow achieving them as well. Based on these, a plan for improving semantic interoperability can then be devised. During this activity, the results of the iShare framework should be used to support in establishing the objectives, since it allows for realizing, from the indicators offered, not only what the present situation is, but also how much it can be improved. Moreover, since the iShare framework provides information about the relevance of the situation, this should be used to prioritize the objectives. Additionally, since the iShare framework is based on the information models of the information systems that are (to be) integrated for the information to be exchanged, it is also possible to identify clearly which actions should be taken, at this level, to address the objectives defined. Moreover, the information about the relevance gathered during the assessment activity can also be used to prioritize the actions identified. In this context, the iShare framework is contributing to the cost-effectiveness of the information sharing solution adopted. In fact, this is an essential activity for achieving the goal of delivering “just enough information”.

The purpose of the last activity (Improve) is to carry out the actions for improving the semantic interoperability of the organizations involved, as specified in the previous activity (Decide). The iShare framework does not provide any specific support to this activity. However, when this activity is completed, the assessment of how its objectives were met must be performed, which will be done when the process is initiated again, during the first activity (Assess).

#### 4.1.2.2 Formulation of strategies for information sharing

The typical activities when defining a strategy (MindTools, 2018) are: 1) the characterization of the external context, 2) the characterization of the internal context, 3) the identification of the strategic options and 4) the evaluation and selection of the strategic options to pursue.

Usually, the external context is made of the aspects which are out of the control of the organization but which (can) affect it. These aspects can be, for example, political, economic, legal or technological, and have the potential to affect it in a positive or negative way, hence are usually called as opportunities and threats, respectively. To identify them, typically a brainstorming is performed, to understand the changes around the organization, followed by the classification of those changes as opportunities or threats, according to how they (can) affect the organization.

The internal context is, on the other hand, quite the opposite. It is made of the aspects that influence the organization but are internal to it, hence are under its control. Examples of these can be human, material and financial resources, liabilities and capabilities. Like the aspects of the external context, those of the internal context can also affect the organization in a positive and in a negative way, for which reason they are usually called as strengths and weaknesses, respectively. The process to identify the organization’s strengths and weaknesses is very similar to the one used for identifying its opportunities and threats.

Figure 18: The typical strategy components

Source: Author



The identification of the strategic options for achieving the organization's objectives is usually done by combining the strengths, weaknesses, opportunities and threats in ways that allow for maximizing opportunities and strengths and minimizing weaknesses and threats, or even for converting some threats into opportunities.

Finally, unfortunately reality determines that resources are finite. Therefore, frequently it is not possible for organizations to pursue all the strategic options identified. Moreover, sometimes those options may also have negative impacts that have not been considered up to this point. For these reasons, it is important to analyze all the strategic options identified and point out each of their positive and (eventual) negative effects, so that only the best ones are selected and pursued.

In this context, the iShare framework can be used for the characterization of the external context in two ways. Firstly, to identify new opportunities, for example by bringing awareness to the information of other organizations that is complementary to the information already held. Secondly, to identify threats.

For example, by realizing that relevant information is not held by any of the organizations analyzed, or that various sources for the same information exist. Likewise, the iShare framework can be used in the characterization of the internal context, either by helping to identify strengths, such as the information that is already available, or by helping to identify weaknesses, such as information that is still missing, or inefficient information sharing processes.

Regarding the identification of the strategic options, the iShare framework is not so helpful, but it becomes relevant again during the evaluation and selection of the strategic options to pursue. In effect, the iShare framework entails determining the relevance of the information to certain business aspects, which can be a valuable contribution for this activity of the strategy formulation.

#### 4.1.2.3 Development of programmes and projects for information sharing

Results-Based Management (RBM) (United Nations Development Group, 2011) is a management strategy by which all actors, contributing directly or indirectly to achieving a set of results, ensure that their processes, products and services contribute to the achievement of desired results (outputs, outcomes and higher-level goals or impact). The actors, in turn, use information and evidence on actual results to inform decision making on the design, resourcing and delivery of programmes and activities as well as for accountability and reporting.

Figure 19: The RBM lifecycle

Source: (United Nations Development Group, 2011)

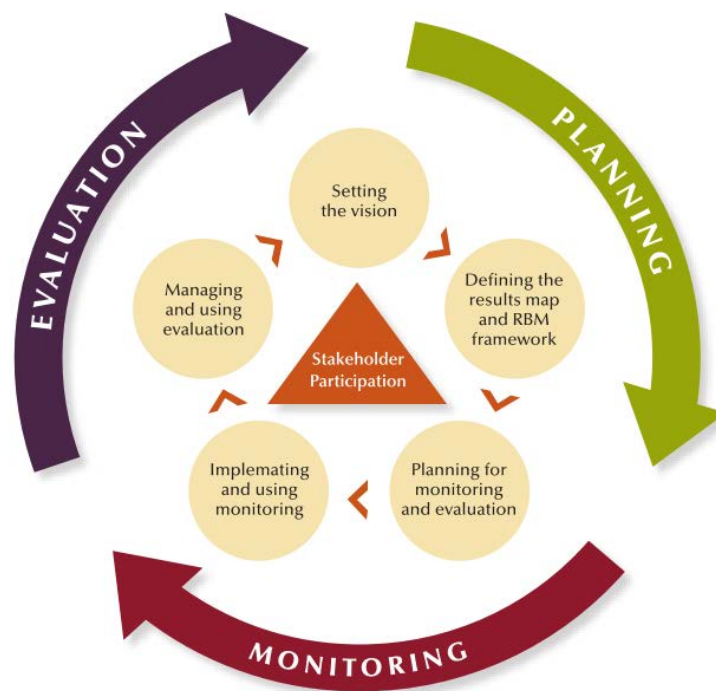

The RBM is a widely used approach, for supporting the development of programmes and projects, by organizations such as the United Nations (UN). It is an iterative approach that, as depicted in Figure 19, starts with planning, which includes elements such as the vision and the results framework. Then, it continues with the implementation and monitoring of the program or project that was agreed upon to achieve the desired objectives. Finally, it ends with the evaluation of the actions taken in face of the results expected, which is then taken into the next iteration.

Because of the need to clarify concepts and to reduce the terminological confusion frequently encountered in these areas, thereby contributing to greater coherence and consistency, as well as to better communication, the Organization for Economic Co-operation and Development (OECD) has compiled a glossary of key terms in in evaluation and RBM (Organisation for Economic Co-operation and Development, 2010) that we will use, from now on, as reference in our work related to this topic.

The planning phase of RBM consists, concisely, in the definition of the outputs and outcomes of the envisioned programme or project. Part of this definition entails the establishment of performance indicators, together with their targets, baselines and benchmarks. Additionally, the activities that will originate the outputs and outcomes abovementioned are also defined during this phase.

In brief, the monitoring phase of RBM consists in the definition and implementation of the monitoring mechanisms that will ensure that the outputs and the expected progress towards the outcomes will be as expected by the end of the programme or project. Such mechanisms are based on the performance indicators, baselines, targets and benchmarks defined during the planning phase.

Finally, the evaluation phase of RMB consists, very succinctly, in the final assessment of a programme or project. Such assessment is again heavily based on the performance indicators, baselines, targets and benchmarks defined during the planning phase. However, the main goal of this phase is not the management of the initiative, since it is already completed, but, instead, the improvement of future initiatives based on the performance of previous ones.

In this context, the iShare framework can provide significant contributions to programmes and projects developed according to the RBM system and which aim the development of information sharing. Namely, it can properly support the definition of impacts and goals, outputs and outcomes, performance indicators, baselines, targets and benchmarks, as well as the activities necessary to achieve the intended results.

## **4.2 Conceptualization of the performance indicators**

The assessment of the semantic interoperability performance of an organization is, in broad terms, a quantification of how much it is semantically interoperable with other organizations, regarding a specific domain. Such performance (or the lack of it) will influence various aspects of the organizations' activity, as we will see, given its role in information sharing.

The purpose of determining the semantic interoperability performance of an organization is, therefore, threefold. First, to enable monitoring and controlling its evolution; second, to enable understanding how it affects the organization and its objectives; and third, to enable benchmarking and comparing different organizations and initiatives.

The assessment of an organization's semantic interoperability performance should be done at least in two

key moments. First, before the decision to enhance semantic interoperability is made, and second, after the activities meant to improve it are realized. While, in the first moment, the purpose is to understand the existing situation and support the decisions to be taken; in the second moment, the purpose is to assess the results of the activities carried out and, therefore, understand if the objectives defined were achieved.

In this context, to design and develop the indicators we applied the methodology developed by Franceschini (Franceschini et al., 2007). This methodology encompasses the activities depicted in the following figure, and the organization of this section is based on them. The “indicators testing” activity will only be described in chapter 7, using a real-world situation.

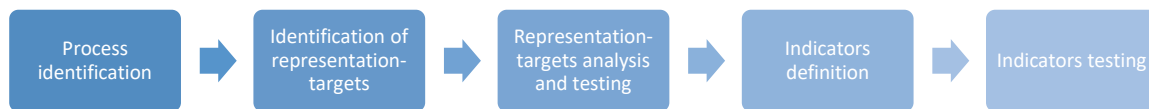

**Source:** Authors based on Franceschini et al., 2007

Figure 20: Process used to define and test the indicators

#### 4.2.1 Objectives

Before designing the performance indicators, we defined the objectives they must meet. They are eight and are a subset of the objectives defined for our framework, and thus contribute to fulfill these, as defined in the following figure. Likewise, they are organized into three groups – effectiveness, efficiency and quality - as follows.

#### 4.2.2 Effectiveness objectives

P1 – to enable determining the present semantic interoperability performance of an organization

P2 – to enable defining the desired semantic interoperability performance of an organization

P3 – to enable defining the possible semantic interoperability performance of an organization

#### 4.2.3 Efficiency objectives

P4 – to be appropriate for large-scale initiatives

P5 – to be cost-effective



#### 4.2.4 Quality objectives

P6 – to be easy to use

P7 – to be independent from the specific domain and case of application

P8 – to adapt to organizational and context changes

Figure 21: Relationship between the framework's and the performance indicators' objectives

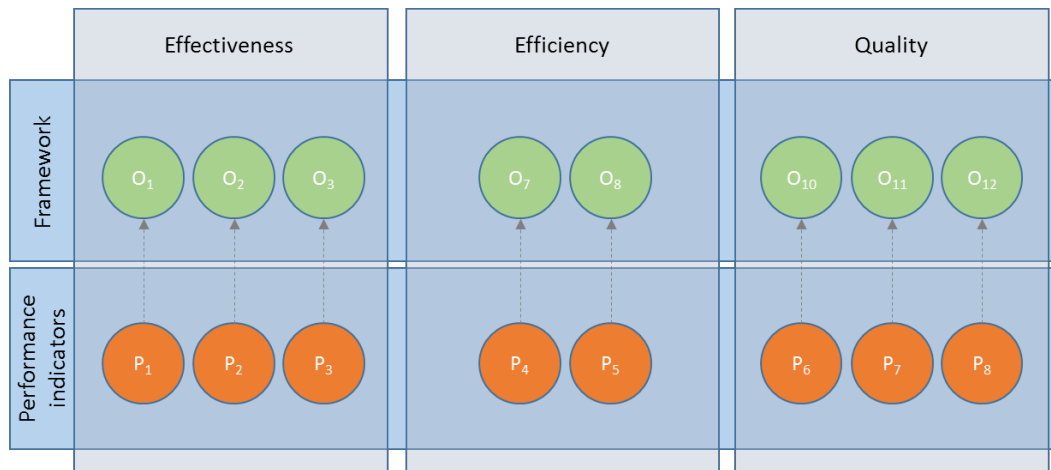

Source: Authors

#### 4.2.5 Process identification

The first step of the methodology is to identify the process which performance we wish to measure. Since semantic interoperability contributes to information exchange, we defined its generic process, which is depicted in the following figure. As explained earlier, information exchange depends on interoperability and this has different dimensions – the legal, the organizational, the semantic and the technological. Since our purpose is to assess the semantic interoperability performance, we identified, in the generic process of information exchange, only the components inherent to semantic interoperability. We will then use these to measure the semantic interoperability performance and so contribute to the information exchange performance assessment. In the future, a similar strategy can be used to assess the other dimensions of information exchange, and so its full complete assessment can be achieved.

Semantic interoperability (European Commission, 2004) enables organizations to process information from external sources in a meaningful manner. It ensures that the precise meaning of the exchanged information is understood and preserved throughout exchanges between parties. It is about the meaning of the data elements and the relationships between them. It includes developing vocabulary to describe the

data exchanges and ensures that data elements are understood in the same way by communicating parties. Therefore, semantic interoperability is:

1. Indispensable to exchange information;
2. Achievable (and hence can be evaluated) without exchanging information.

The main purpose of an information model (Pras & Schoenwaelder, 2003) is to model managed objects at a conceptual level, independent of any specific implementations. Data models (Pras & Schoenwaelder, 2003), on the other hand, are defined at a lower level of abstraction, include many details, and are intended for implementers. Multiple data models can be derived from a single information model.

Figure 22: Information sharing high-level process

Source: Author

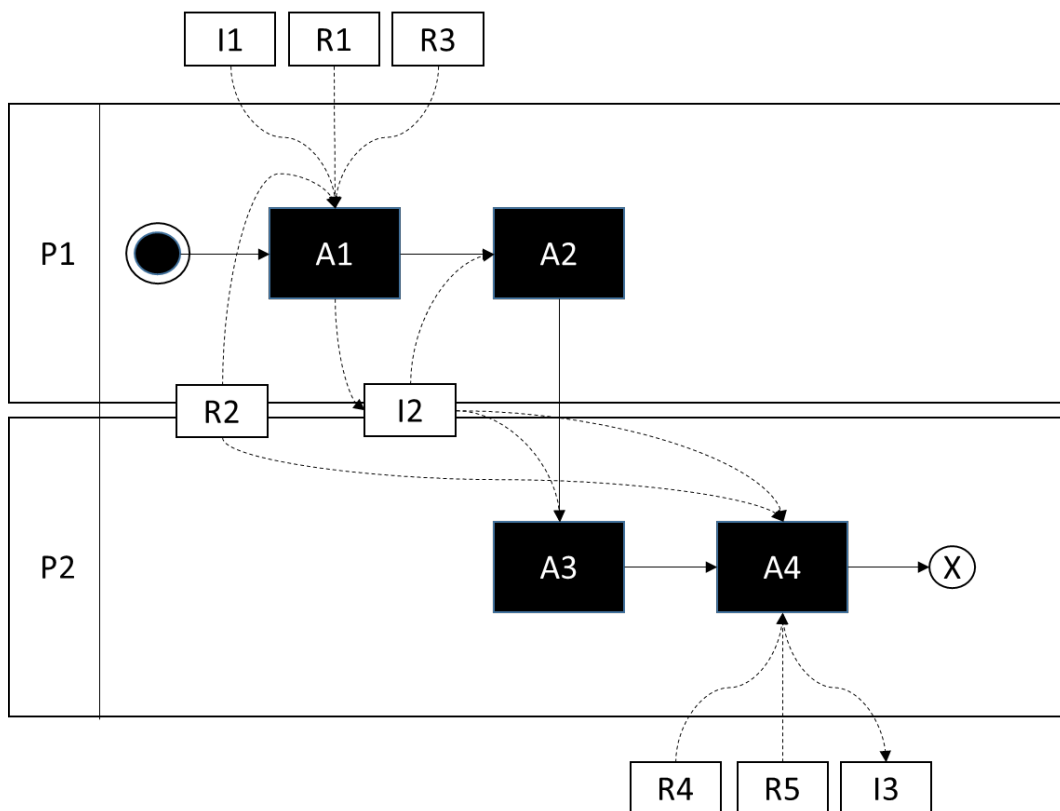

Considering that the vocabulary needed by semantic interoperability to describe the data exchanges can

be an information model, semantic interoperability requires:

- 1) Participants information models;
- 2) A common information model for describing the information exchanged between the participants;
- 3) Mappings, between the common and the other information models, establishing their conceptual relationships;
- 4) Definitions of the transformations between the common and the other information models, which preserve the meaning of the information.

Therefore, the role of semantic interoperability can be observed in the information sharing high-level process depicted in the previous picture. In this process, to accomplish an exchange of information between two participants, the information provider (P1) and the information consumer (P2), several activities (A1 to A4) are performed and several resources (R1 to R5) are involved, producing semantically equivalent information (I1 to I3), as follows:

- **A1:** P1 translates the information to share (I1) from its IM (R1) into the CIM (R2), according to the mappings and transformations (R3) defined between R1 and R2, producing I2;
- **A2:** P1 sends the information (I2) to P2;
- **A3:** P2 receives the information (I2) from P1;
- **A4:** P2 translates the information received (I2) from the CIM (R2) into its own IM (R4), according to the mappings and transformations (R5) defined between R2 and R4, producing I3.

Upon completion, P2 will process the received information as adequate, and the precise meaning of I1 is exactly the same of I3, for P1 and P2; otherwise, the information exchange did not succeed.

#### 4.2.6 Identification of the representation-targets

A representation-target (Franceschini et al., 2007) is the operation aimed to make a context, or parts of it, “tangible” in order to perform evaluations, make comparisons, formulate predictions or take decisions. According to the methodology followed, they must be identified for each of the process dimensions selected, which we have done for semantic interoperability. The representation-targets identified are, therefore, the following:

- **Information available** Information held by a participant in the process;
- **Information needed** Information needed by the business processes of an organization;
- **Information required** Information needed by a participant in the process that it can consume;
- **Information mapped**
  - **Information mapped for provisioning** transformations defined to provide the

information to other participants in the process;

- **Information mapped for consumption** transformations defined to consume the information provided by other participants in the process;
- **Information to be provided**
  - **Information that could be provided** Information that is already defined in the systems of the potential providers and consumers
  - **Information that should be provided** Information that could be provided that is required by at least another participant in the process;
  - **Information that must be provided** Information that should be provided and which transformations into the CIM are defined;
- **Information to be consumed**
  - **Information that could be consumed** Information that could be provided by other participants in the process and which is already defined in the systems of the potential consumers;
  - **Information that should be consumed** Information that could be consumed that is required by a participant;
  - **Information that must be consumed** Information that should be consumed and which transformations from the CIM into the destination systems are defined;
- **Performance**
  - **Performance as an information provider** Relationship between the information a participant is required to provide and what is possible, considering the existing semantic interoperability
  - **Performance as an information consumer** Relationship between the information a participant is required to consume and what is possible, considering the existing semantic interoperability
  - **Overall performance** Relationship between the participant performance as an information consumer and provider

#### 4.2.7 Analysis and testing of the representation-targets

Indicators must be consistent with the strategic objectives of information sharing, and this is achieved if they have the Accessory Properties (Franceschini et al., 2007). The first of these properties is “Long Term Goals”. Indicators with this property should encourage the achievement of the process long term goals, therefore representation-targets should concern process dimensions that are strictly linked to these goals. The second property, “Impact on Stakeholders”, implies that the impact of each indicator on the process stakeholders is carefully analyzed. Therefore, it is important to identify process aspects with a strong impact on customer satisfaction.

Table 3: Accessory properties

a - long term goals	a1 - the information sharing should be effective a2 - the information sharing should be efficient
b - impact on stakeholders	b1 - any party involved in the information sharing should be able to obtain all the information required

Source: Author

To test the representation-targets we have refined the accessory properties as presented in Table 3, and concluded that all the representation-targets are consistent with the information sharing strategic objectives.

### 4.3 Conceptualization of the relevance indicators

#### 4.3.1 Objectives

To conceptualize the relevance indicators, we followed the same methodology used with the performance indicators. As such, before designing the indicators, we defined the objectives they must meet. They are nine and are a subset of the objectives defined for our framework. Thus, they contribute to fulfill those, as depicted in the following figure. Likewise, they are organized into three groups – effectiveness, efficiency and quality - as follows.

#### 4.3.2 Effectiveness objectives

R1 – to enable determining the relevance of the present semantic interoperability of an organization

R2 – to enable defining the relevance of the desired semantic interoperability of an organization

R3 – to enable defining the relevance of the possible semantic interoperability of an organization

#### 4.3.3 Efficiency objectives

R4 – to be appropriate for large-scale initiatives

R5 – to be cost-effective

R6 - to enable consensus among the organizations involved

#### 4.3.4 Quality objectives

R7 – to be easy to use

R8 – to be independent from the specific domain and case of application

R9 – to adapt to organizational and context changes

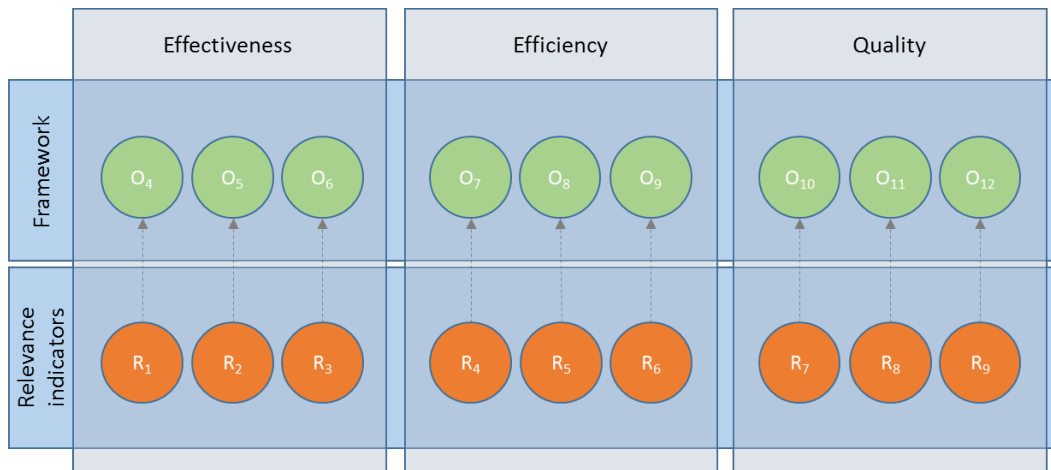
**Figure 23:** Relationship between the framework's and the relevance indicators' objectives**Source:** Authors

#### 4.3.5 Process and representation-targets

According to the methodology adopted, the next steps after defining the objectives are the definition of the process and of the representation-targets. In this case, we will use the same process adopted for the definition of the performance indicators. Likewise, we will define the relevance indicators based on the representation targets defined earlier for the performance indicators, which are already analyzed and tested.

## **5 Core concepts**

The core concepts are various elements that characterize an information sharing process, from the semantic interoperability point of view. They describe not only the participants, their information systems and other capabilities required to exchange information, but also the information needs and availability.

The core concepts are the foundations of the indicators we will define and characterize the information exchange process by using two different perspectives. The perspective of the information to be consumed and the perspective of the information to be provided. More specifically, from the consumption point of view, we should be able to understand how much information can be consumed, how much of it is required, and how much of it is actually possible to consume and how much of it is actually being consumed. And the same is applies from the provisioning point of view. Without understanding this, it will not be possible to understand the situation, nor how can it possibly be improved.

Moreover, the core concepts characterize the process at two different levels - the organization level and the system level. The characterization at the organization level is the grounds for developing all facets of interoperability (operational, legal, semantic and technical), whereas the characterization at the system level is essential for developing the semantic interoperability and provides a good basis for developing the technical interoperability.

The core concepts are based on two types of information elements. Those from the CIM and those from the systems of the participants which implement CIM elements. On the one hand, the characterization of the information exchange process, from the point of view of the CIM elements, is very important, because it is what allows us to understand the generic needs and availability of information, at the system and at the participant level. On the other hand, using the system elements to characterize the information exchange process will allow us to work at a finer level of detail, which is the right one to assess the impact and performance of semantic interoperability.

### **5.1 Performance**

In this section, the core concepts relevant for the definition of the performance indicators are explained and defined informally and formally. In addition, examples are provided based on the information sharing scenario previously introduced and detailed in appendix 1. These concepts are also summarized in appendix 2.

#### **5.1.1 Participants**

A participant in the information sharing process is an organization that either requires information or holds information required by other organizations. For any of these reasons, often both, participants are willing to exchange information among themselves, thereby assuming the roles of information consumers or providers, accordingly. As depicted in the following table, the set of participants in the information exchange process is designated by 'P'. Each participant in the information exchange is then designated by



‘P’, followed by an order number.

Table 4: Participants

<i>Name</i>	<i>Participants (P)</i>
<b><i>Informal definition</i></b>	Set of all organizations with a role in the information sharing process, which can be that of an information provider, consumer, or both
<b><i>Formal definition</i></b>	$P = \{p_1, p_2, p_3, \dots, p_n\}$
<b><i>Example</i></b>	$P = \{P1, P2, P3\}$

**Source:** Author

### 5.1.2 Common Information Model

To be cost-effective, the information should be exchanged, among the organizations, through a commonly defined information model – a common information model (CIM). An information model, comprises various information elements (i.e. objects and attributes), as well as the relationships among those objects (Pras & Schoenwaelder, 2003), which are, in practice, defined in terms of information elements as well. As depicted in the following table, we designate the set of CIM information elements by ‘ $A_{CIM}$ ’, and each CIM information element by ‘A’, followed by an order number.

Table 5: Elements of the Common Information Model

<i>Name</i>	<i>CIM elements (<math>E_{CIM}</math>)</i>
<b><i>Informal definition</i></b>	Set of all CIM information elements
<b><i>Formal definition</i></b>	$E_{CIM} = \{a_1, a_2, a_3, \dots, a_n\}$
<b><i>Example</i></b>	$E_{CIM} = \{I1, I2, I3, I4, I5, I6, I7\}$

**Source:** Author

### 5.1.3 Information systems

The information exchanged in the process will be retrieved from and inserted into the information systems of the participants as necessary. Assuming each information system involved in the process has its own specific information model, their information elements are most likely implemented differently among themselves and from the CIM.

For developing our semantic interoperability indicators, we are not interested in the details of the specific

implementation of each of the CIM attributes in each of the systems involved in the process; rather, we are only interested in understanding if each CIM element is implemented in a specific system or not, and if a way to transform each CIM element into the corresponding participant system element is defined or not. In other words, we are interested to know if there is semantic interoperability between the system and the CIM. Therefore, the representation of a CIM information attribute in a system is an abstraction from such details that serves our purpose.

As depicted in the following table, the set of information systems, from any organization, that implement at least one information element of the CIM is designated by ‘S’, followed by the order number of the organization who owns the system. An example is the system designated as S1.1, which is the first system belonging to organization P1.

Table 6: Systems of a participant

<i>Name</i>	<i>Systems of a participant (S<sub>P</sub>)</i>
<b><i>Informal definition</i></b>	Set of the participant’s systems which implement CIM elements
<b><i>Formal definition</i></b>	$\forall p \in P, \forall n \in N,$  $S_p = \{S_1, S_2, S_3, \dots, S_n\}$
<b><i>Example</i></b>	$S_{P1} = \{S1.1, S1.2\}$  $S_{P2} = \{S2.1, S2.2, S2.3\}$  $S_{P3} = \{S3.1, S3.2\}$

**Source:** Author

Consequently, the set of all participants’ systems which implement at least on CIM information element is designated by ‘S’, as depicted in the following table.

**Table 7:** All systems

<b>Name</b>	<i>All systems (S)</i>
<b>Informal definition</b>	Set of all participants' systems which implement (or are expected to) CIM elements
<b>Formal definition</b>	$S = \bigcup_{i=1}^n S_i$ $\forall i \in \mathbb{N}, \quad n =  P $
<b>Example</b>	$S = \{S1.1, S1.2, S2.1, S2.2, S2.3, S3.1, S3.2\}$

**Source:** Author

#### 5.1.4 Information transformations

Considering that the information is to be exchanged through the CIM, and assuming that the information models of the systems involved in the process differ from it, it becomes necessary to develop technological capabilities to transform the information from one model into the other, ensuring that its meaning is preserved.

For this purpose, we will assume that information services will be used, in the context of a service-oriented architecture (SOA) (The Open Group, 2009), to support the information sharing process by acting as bridges between the CIM and the information models of the systems involved (e.g. we can define one service to be responsible for the transformation of the information exchanged between each particular system and the CIM). These services will, therefore, implement functions that will be responsible for transforming each of the CIM information elements into the corresponding implementation in a given system, and the other way around.

We designate the transformation services of a participant by 'T', followed by the order number of the participant considered. These are, therefore, those that the participant has implemented to transform its systems' elements into CIM elements and vice-versa. Each service is then, in our scenario, represented by 'T' followed by the participant number and by an order number. For example, while participant P1 has the transformation service T1.2, participant P2 has none, which means that presently, he is not semantically interoperable because he cannot perform the necessary transformations.

**Table 8:** Transformation services of a participant

<i>Name</i>	<i>Transformation services of a participant (<math>T_p</math>)</i>
<i>Informal definition</i>	Set of all participant services that are used to transform the system elements into the corresponding CIM elements and the other way around.
<i>Formal definition</i>	$\forall p \in P$ $T_p = \{t1, t2, t3, \dots, tn\}$
<i>Example</i>	$T_{p1} = \{T1.2\}$ $T_{p2} = \emptyset$ $T_{p3} = \{T3.1\}$

**Source:** Author

Consequently, the set comprising all the transformation services of all the participants is designated by ‘T’, as depicted in the following table. According to our scenario, only two transformation services are presently implemented (T1.2 and T3.1) by participants P1 and P3, respectively.

**Table 9:** All transformation services

<i>Name</i>	<i>All transformation services (<math>T</math>)</i>
<i>Informal definition</i>	Set of all transformation services of all participants.
<i>Formal definition</i>	$\forall i \in \mathbb{N}, \forall p \in P$ $T = \bigcup_{i=1}^{ P } T_{p_i}$
<i>Example</i>	$T = \{T1.2, T3.1\}$

**Source:** Author

Each service will therefore contain various functions to perform the necessary transformations. In this context, we consider that the function to transform a CIM element into a system element is different from the function that does the opposite. Therefore, the latter is designated by ‘f’, followed by the designation of the CIM element it returns. Its input parameter is the system element to be transformed, as depicted in the following table. For example, function  $f_{i1}$ , transforms the system element  $S1.2_{i1}$  into the corresponding CIM element  $I1$ . From our scenario we can see that only participant P1 is able to provide information to others, specifically the CIM element  $I1$ .

**Table 10:** Transformation of a system element into a CIM element

<i>Name</i>	<i>Transformation of a system element into a CIM element (<math>f_a</math>)</i>
<i>Informal definition</i>	Function that transforms a system element into its corresponding CIM element (mapping for provisioning)
<i>Formal definition</i>	$\forall s \in S, \forall r \in R_s, \forall a \in A_s$ $f_a: R_s \rightarrow A_s, a = f_a(r)$
<i>Example</i>	$I1 = f_{I1}(S1.2_{I1})$

**Source:** Author

Likewise, the functions that transform a CIM element into a system element are, as depicted in the following table, designated by ‘g’, followed by the designation of the system element that they return. Its input parameter is the CIM element to be transformed. For example, function  $g_{S1.2}$  transforms the CIM element I3 into its corresponding implementation in system S1.2, which is designated by S1.2<sub>I3</sub>. From the scenario, we can see that only participant P2 is not able to consume any information, because it has no functions to transform CIM elements into its system elements.

**Table 11:** Transformation of a CIM element into a system element

<i>Name</i>	<i>Transformation of a CIM element into a system element (<math>g</math>)</i>
<i>Informal definition</i>	Function that transforms a CIM element into its corresponding system element (retraction of $f$ ) (mapping for consumption)
<i>Formal definition</i>	$\forall s \in S, \forall r \in R_s, \forall a \in A_{CIM}$ $g: A_s \rightarrow R_s, r = g_s(f(r))$
<i>Example</i>	$S1.2_{I3} = g_{S1.2}(I3)$ $S3.1_{I6} = g_{S3.1}(I6)$ $S1.2_{I4} = g_{S1.2}(I4)$ $S3.2_{II} = g_{S3.2}(II)$

**Source:** Author

As said, the transformation functions are implemented within the transformation services. So, the set of functions of a transformation service are designated by ‘F’, followed by the designation of the transformation service considered. For example, the set of transformation functions of service T3.1 are designated by  $F_{T3.1}$  and include the functions  $g_{S3.1}$  and  $g_{S3.2}$ .

**Table 12:** Functions of a transformation service

<i>Name</i>	<i>Functions of a transformation service (<math>F_T</math>)</i>
<i>Informal definition</i>	Set of all functions which are implemented in a transformation service
<i>Formal definition</i>	$\forall t \in T$ $F_t = \{f_1, f_2, f_3, \dots, f_n\} \cup \{g_1, g_2, g_3, \dots, g_n\}$
<i>Example</i>	$F_{T1.2} = \{S1.2_{I3} = g_{s1.2}(I3), S1.2_{I4} = g_{s1.2}(I4), I1 = f_{I1}(S1.2_{I1})\}$ $F_{T3.1} = \{S3.1_{I6} = g_{s3.1}(I6), S3.2_{I1} = g_{s3.2}(I1)\}$

**Source:** Author

### 5.1.5 Information available

Any system involved in the information exchange process has to implement at least one of the CIM information elements. Otherwise, it cannot receive nor provide any information. The set containing all the CIM elements implemented in a system is therefore designated by ‘EA’, followed by the designation of the system considered, as depicted in the following table.

**Table 13:** CIM elements available in a system

<i>Name</i>	<i>CIM elements available in a system (<math>EA_S</math>)</i>
<i>Informal definition</i>	Set of the CIM elements implemented in a system
<i>Formal definition</i>	$\forall s \in S,$ $EA_S \subseteq E_{CIM}$
<i>Example</i>	$EA_{S1.1} = \{I1, I2\}$ $EA_{S1.2} = \{I1, I3, I4\}$ $EA_{S2.1} = \{I4, I5, I6\}$ $EA_{S2.2} = \{I1, I2\}$ $EA_{S2.3} = \{I3\}$ $EA_{S3.1} = \{I5, I6\}$ $EA_{S3.2} = \{I1, I7\}$

**Source:** Author

For a participant to be involved in an information exchange initiative, it must have at least one system, which contains at least one of the CIM elements. Therefore, all the CIM elements available by a participant are all the CIM elements implemented in each of its systems, which is designated by ‘EA’, followed by the designation of the participant considered, as depicted in the following table.

**Table 14:** CIM elements available in a participant

<b>Name</b>	<b>CIM elements available in a participant (<math>EA_p</math>)</b>
<b>Informal definition</b>	Set of all CIM information elements which are implemented in all the systems of a participant
<b>Formal definition</b>	$\forall p \in P, \forall i \in \mathbb{N}, \forall s \in S_p$ $EA_p = \bigcup_{i=1}^{ S_p } EA_{s_i}$
<b>Example</b>	$EA_{P1} = \{I1, I2, I3, I4\}$ $EA_{P2} = \{I1, I2, I3, I4, I5, I6\}$ $EA_{P3} = \{I1, I5, I6, I7\}$

**Source:** Author

Consequently, the set of CIM elements of all systems is the collection of all the CIM elements implemented in each system of each participant. This is designated by 'E', as depicted in the following table. Considering the scenario, we can see that all the CIM elements are implemented by at least one of the systems involved, which means that within this community of participants all the information about the domain of interest is available.

**Table 15:** CIM elements in all systems

<b>Name</b>	<b>CIM elements in all systems (<math>E</math>)</b>
<b>Informal definition</b>	Set of all CIM information elements implemented in all systems
<b>Formal definition</b>	$\forall i \in \mathbb{N}, \forall s \in S$ $E = \bigcup_{i=1}^{ S } EA_{s_i}$
<b>Example</b>	$E = \{I1, I2, I3, I4, I5, I6, I7\}$

**Source:** Author

As said, the CIM elements are often implemented differently in the various systems, which is the reason for the lack of interoperability among them. These implementations, which we designate by system elements, are representations of CIM elements. Consequently, we designate each system element by the designation of the system it belongs to, followed by the designation of the CIM element it represents. For example, S1.1<sub>I1</sub> is the designation for the system element implemented in system S1.1 that implements

the CIM element I1. Therefore, the set comprising all the system elements of a system is designated by ‘R’, followed by the designation of the system considered, as depicted in the following table. For example,  $R_{S1.1}$  designates all system elements comprised in system S1.1.

**Table 16:** System elements available in a system

<i>Name</i>	<i>System elements available in a system (<math>RA_S</math>)</i>
<i>Informal definition</i>	Set of all system elements which implement CIM information elements
<i>Formal definition</i>	$\forall s \in S$ $RA_S = \{r_1, r_2, r_3, \dots, r_n\}$
<i>Example</i>	$RA_{S1.1} = \{S1.1_{I1}, S1.1_{I2}\}$ $RA_{S1.2} = \{S1.2_{I1}, S1.2_{I3}, S1.2_{I4}\}$ $RA_{S2.1} = \{S2.1_{I4}, S2.1_{I5}, S2.1_{I6}\}$ $RA_{S2.2} = \{S2.2_{I1}, S2.2_{I2}\}$ $RA_{S2.3} = \{S2.3_{I3}\}$ $RA_{S3.1} = \{S3.1_{I5}, S3.1_{I6}\}$ $RA_{S3.2} = \{S3.2_{I1}, S3.2_{I7}\}$

**Source:** Author

Consequently, each participant has various implementations of CIM elements in its systems. These are designated by ‘R’, followed by the designation of the participant considered, as depicted in the following table. For example, participant P1 has the CIM element I1 implemented in its system S1.1, which is designated by  $S1.1_{I1}$ , as depicted in the following table.

**Table 17:** Participant systems’ elements

<i>Name</i>	<i>System elements available in a participant (<math>RA_p</math>)</i>
<i>Informal</i>	Set comprising all the participant systems’ information elements which implement

**Source:** Author



<i>definition</i>	CIM information elements
<i>Formal definition</i>	$\forall s \in S_p, \forall p \in P, \forall i \in \mathbb{N}$ $RA_p = \bigcup_{i=1}^{ S_p } RA_{s_i}$
<i>Example</i>	$R_{p1} = \{S1.1_{I1}, S1.1_{I2}, S1.2_{I1}, S1.2_{I3}, S1.2_{I4}\}$ $R_{p2} = \{S2.1_{I4}, S2.1_{I5}, S2.1_{I6}, S2.2_{I1}, S2.2_{I2}, S2.3_{I3}\}$ $R_{p3} = \{S3.1_{I5}, S3.1_{I6}, S3.2_{I1}, S3.2_{I7}\}$

### 5.1.6 Information needed

The CIM elements needed by an organization are all those that it needs for its business processes, regardless of being implemented in its information systems or not. We designate them by ‘EN’ followed by the designation of the participant considered. For example, participant P3 would like to consume all CIM elements from other participants, if available, whereas participant P2 does not require any. However, from the scenario, we can see that P2 has many of the CIM elements in its systems, which makes him a good candidate for providing information to other participants.

**Table 18:** CIM elements required by a participant

<i>Name</i>	<b><i>CIM elements needed by a participant (<math>EN_p</math>)</i></b>
<i>Informal definition</i>	Set of all CIM elements that a participant needs, regardless of being implemented on its systems or not
<i>Formal definition</i>	$\forall p \in P$ $EN_p \subseteq E_{CIM}$
<i>Example</i>	$ER_{P1} = \{I3, I4, I5, I7\}$ $ER_{P2} = \emptyset$ $ER_{P3} = \{I1, I2, I3, I4, I5, I6, I7\}$

**Source:** Author

Consequently, the CIM elements needed by all participants, depicted in the table below, are the set of all CIM elements which the participants would like to receive from each other. This set is designated by ‘EN’ an, from the scenario we can see that all CIM elements are required by the participants, which is a good indicator of the relevance of the CIM for this group of participants, as well.

**Table 19:** CIM elements needed by all participants

<i>Name</i>	<b><i>CIM elements needed by all participants (<math>EN</math>)</i></b>
-------------	---

<i>Informal definition</i>	Set of all CIM elements needed by at all participant
<i>Formal definition</i>	$\forall i \in \mathbb{N}, \forall p \in P$ $EN = \bigcup_{i=1}^{ P } EN_{pi}$
<i>Example</i>	$ER = \{I1, I2, I3, I4, I5, I6, I7\}$

**Source:** Author

### 5.1.7 Information required

However, often, from the business point of view, organizations need information which their information systems are not yet ready to consume. Therefore, since semantic interoperability cannot be established when the systems do not have implemented representations of the CIM elements that are needed, we need to know the CIM elements needed that are implemented in the systems of a participant, since these are the only ones that can be required in the context of an information exchange initiative. The set of these elements is designated by ‘ER’, followed by the designation of the participant considered. In the scenario, participant P1 requires and has implemented the CIM elements I3 and I4, and although it also requires I5 and I7, it cannot work on their semantic interoperability, because these CIM elements are not implemented in P1 systems.

**Table 20:** CIM elements required by a participant

<i>Name</i>	<i>CIM elements required by a participant (ER<sub>P</sub>)</i>
<i>Informal definition</i>	Set of all CIM elements that a participant needs and that are implemented in at least one of its systems
<i>Formal definition</i>	$\forall p \in P$ $ER_p = EN_p \cap EA_p$
<i>Example</i>	$ER_{P1} = \{I3, I4\}$ $ER_{P2} = \emptyset$ $ER_{P3} = \{I1, I5, I6, I7\}$

**Source:** Author

Likewise, the set of CIM elements required by a system, depicted in the following table, is the collection of all CIM elements required by the participant that are implemented in that particular system. This set is designated by ‘ER’, followed by the designation of the system considered. For example, in the scenario we can see that system S1.2 implements the CIM elements the CIM elements I3 and I4, required by the

participant. Likewise, since participant P2 does not require any CIM element, and although it does implement various CIM elements in its systems, none of its systems requires any CIM element.

**Table 21:** CIM elements required by a system

<i>Name</i>	<i>CIM elements required by a system (<math>ER_s</math>)</i>
<i>Informal definition</i>	Set of all CIM elements that are required by a system
<i>Formal definition</i>	$\forall s \in S_p, \forall p \in P$ $ER_s = EA_s \cap ER_p$
<i>Example</i>	$ER_{S1.1} = \emptyset$ $ER_{S1.2} = \{I3, I4\}$ $ER_{S2.1} = ER_{S2.2} = ER_{S2.3} = \emptyset$ $ER_{S3.1} = \{I5, I6\}$ $ER_{S3.2} = \{I1, I7\}$
<i>Notes</i>	If a system implements a CIM element that is required by the participant, then inherently the system requires the CIM element

**Source:** Author

Participants express their information needs in terms of the CIM information elements. But to understand the actual semantic interoperability requirements, we need to identify, for each system, the elements which implement CIM elements required by the participant. These are the system elements for which the participant has to develop the necessary semantic interoperability to consume their corresponding CIM elements. The set of these elements is designated by ‘RR’, followed by the designation of each system considered, as depicted in the following table. As we can see in our scenario, participant P1 has to develop the necessary semantic interoperability to consume I3 and I4 in to S1.2<sub>I3</sub> and S1.2<sub>I4</sub> (which he already did), and does not have to develop anything regarding S1.1, because he does not require I1 nor I2.

**Table 22:** System elements required by a system

<i>Name</i>	<i>System elements required by a system (<math>RR_s</math>)</i>
<i>Informal definition</i>	Set of all system elements that implement CIM elements which are required by the participant
<i>Formal definition</i>	$\forall i \in \mathbb{N}, \forall p \in P, \forall s \in S_p, \forall a \in ER_p$ $RR_s = RA_s \cap ( \cup_{i=1}^{ ER_p } g_s(a_i) )$

*Example*  $RR_{S1.1} = \emptyset$   
 $RR_{S1.2} = \{S1.2_{I3}, S1.2_{I4}\}$   
 $RR_{S2.1} = \emptyset$   
 $RR_{S2.2} = \emptyset$   
 $RR_{S2.3} = \emptyset$   
 $RR_{S3.1} = \{S3.1_{I5}, S3.1_{I6}\}$   
 $RR_{S3.2} = \{S3.2_{I1}, S3.2_{I7}\}$

To have an overall understanding of the semantic interoperability work that has to be done in all of the participants systems, to consume CIM elements, we defined the set of all participants' systems elements that implement CIM elements required by the participant, as depicted in the following table. It is designated by 'RR', followed by the designation of the participant considered. According to our scenario, participant P3, for example, has to develop its semantic interoperability to consume the required elements I1, I5, I6 and I7, into its systems S3.1 and S3.2, specifically into its system elements S3.1<sub>I5</sub>, S3.1<sub>I6</sub>, S3.2<sub>I1</sub> and S3.2<sub>I7</sub>.

**Table 23:** System elements required

<i>Name</i>	<i>System elements required by a participant (RR<sub>p</sub>)</i>
<i>Informal definition</i>	Set of all participant systems' elements that implement CIM elements which are required by the participant
<i>Formal definition</i>	$\forall i \in \mathbb{N}, \quad \forall p \in P, \quad \forall s \in S_p$ $RR_p = \bigcup_{i=1}^{ S_p } RR_{S_i}$
<i>Example</i>	$RR_{p1} = \{S1.2_{I3}; S1.2_{I4}\}$ $RR_{p2} = \emptyset$ $RR_{p3} = \{S3.1_{I5}; S3.1_{I6}; S3.2_{I1}; S3.2_{I7}\}$

**Source:** Author

## 5.1.8 Information mapped

### 5.1.8.1 Information mapped for provisioning

There may be the case where a participant has already defined the necessary transformations to provide CIM elements implemented in its systems. In this case, semantic interoperability is implemented, but just enough to provide the information required by the other participants. However, for this to happen, it is also necessary to develop a technological solution and the right legal framework. The set of CIM elements mapped for provisioning by a participant, depicted in the following table, is designated by 'EMP', followed by the designation of the participant considered. In our scenario, participant P1 has established the semantic interoperability to provide CIM element I1 to other participants such as P3,

which requires it.

**Table 24:** CIM elements mapped for provisioning by a participant

<i>Name</i>	<i>CIM elements mapped for provisioning by a participant (<math>EMP_p</math>)</i>
<i>Informal definition</i>	Set of all CIM elements which transformations for its provisioning have already been defined by a participant
<i>Formal definition</i>	$\forall p \in P$ $EMP_p \subseteq EA_p$
<i>Example</i>	$EMP_{P1} = \{I1\}$ $EMP_{P2} = \emptyset$ $EMP_{P3} = \emptyset$

**Source:** Author

However, in our scenario, participant P1 has the CIM element I1 implemented in two of its systems (i.e. S1.1 and S1.2) so, although he is able to provide I1, he is not able to provide I1 from all its systems. Consequently, as long as I1 is required by other participants, P1 should develop the semantic interoperability necessary to provide I1 from all its systems. This can only be detected if the analysis is done at the system level. Therefore, in the following table, we define the CIM elements mapped for provisioning by a system. The set of these elements is designated by ‘EMP’, followed by the designation of the system considered.

**Table 25:** CIM elements mapped for provisioning by a system

<i>Name</i>	<i>CIM elements mapped for provisioning by a system (<math>EMP_s</math>)</i>
<i>Informal definition</i>	Set of all CIM elements which transformations for its provisioning by a system have already been defined
<i>Formal definition</i>	$\forall p \in P, \forall s \in S$ $EMP_s \subseteq EA_s \cap EMP_p$
<i>Example</i>	$EMP_{S1.2} = \{I1\}$ $EMP_{S1.1} = EMP_{S2.1} = EMP_{S2.2} = EMP_{S2.3} = EMP_{S3.1} = EMP_{S3.2} = \emptyset$

**Source:** Author

When a participant has CIM elements required by other participants, and if it will provide them, the semantic interoperability between the system elements that implement those CIM elements and the CIM elements has to be established. The set of the system elements which semantic interoperability was already established, is depicted in the following table. It is designated by ‘RMP’, followed by the designation of the system considered. According to our scenario, for example, P1 has developed the semantic interoperability to provide I1 from S1.2 to P3, but has not developed the semantic interoperability to provide the same CIM element from S1.1.

**Table 26:** System elements mapped for provisioning

<i>Name</i>	<i>System elements mapped for provisioning by a system (RMP<sub>s</sub>)</i>	
<i>Informal definition</i>	Set of all system elements which mappings to provide the corresponding CIM elements have been defined	
<i>Formal definition</i>	$\forall i \in \mathbb{N}, \forall s \in S, \forall a \in EMP_s$ $RMP_s = \bigcup_{i=1}^{ EMP_s } g_s(a_i)$	
<i>Example</i>	$RMP_{S1.1} = \emptyset$ $RMP_{S1.2} = S1.2_{I1}$ $RMP_{S2.1} = \emptyset$ $RMP_{S2.2} = \emptyset$	$RMP_{S2.3} = \emptyset$ $RMP_{S3.1} = \emptyset$ $RMP_{S3.2} = \emptyset$
<i>Notes</i>	They are available and mapped to be provided, but this does not mean that presently they are not required by any of the participants	

**Source:** Author

The collection of all the semantic interoperability developments already done by a participant, in all its systems, is depicted in the following table. It is designated by ‘RMP’, followed by the designation of the participant considered. In our scenario, P1 has only developed the semantic interoperability to provide one of its implementations of I1 (S1.2<sub>I1</sub>), whereas the remainder participants have developed none.

**Table 27:** System elements mapped for provisioning by a participant

<i>Name</i>	<i>System elements mapped for provisioning by a participant (RMP<sub>p</sub>)</i>	
<i>Informal definition</i>	Set of all information elements, from all the participant systems, which mappings to provide the corresponding CIM elements have been defined	
<i>Formal definition</i>	$\forall i \in \mathbb{N}, \forall s \in S_p, \forall p \in P$ $RMP_p = \bigcup_{i=1}^{ S_p } RMP_{s_i}$	
<i>Example</i>	$RMP_{p1} = \{S1.2_{I1}\}$	

$$RMP_{p2} = \emptyset$$

$$RMP_{p3} = \emptyset$$

**Source:** Author

### 5.1.8.2 Information mapped for consumption

There may be the case where a participant has already defined the necessary transformations (mappings) to consume CIM elements into its systems. In this case, we consider that semantic interoperability has been established between the CIM elements and their corresponding system elements. However, to consume this information from the CIM, at least a technological solution and a legal framework have to be in place. The set of CIM elements which transformations have been defined is designated by ‘EMC’, followed by the designation of the participant considered. In our scenario, participant P1 has established the necessary semantic interoperability to consume CIM elements I3 and I4, into its system S1.2, specifically into its system elements S1.2<sub>I3</sub> and S1.2<sub>I4</sub>, respectively.

**Table 28:** CIM elements mapped for consumption by a participant

<i>Name</i>	<i>CIM elements mapped for consumption by a participant (EMC<sub>P</sub>)</i>
<i>Informal definition</i>	Set of all CIM elements which transformations functions for its consumption have already been defined by a participant
<i>Formal definition</i>	$\forall p \in P$ $EMC_p \subseteq EA_p$
<i>Example</i>	$EMC_{P1} = \{I3, I4\}$ $EMC_{P2} = \emptyset$ $EMC_{P3} = \{I1, I6\}$

**Source:** Author

We also provide a way to understand the same information at the system level. The set of CIM elements mapped for consumption by a system is the set of CIM elements, represented in a specific system, that are required by the participant who owns it. This set is designated by ‘EMC’, followed by the designation of the system considered, as depicted in the following table.

**Table 29:** CIM elements mapped for consumption by a system

<i>Name</i>	<i>CIM elements mapped for consumption by a system (EMC<sub>S</sub>)</i>
<i>Informal definition</i>	Set of all CIM elements which transformation functions for its consumption by a system have already been defined by a participant
<i>Formal</i>	$\forall p \in P, \forall s \in S_p$

**Source:** Author

*definition*  $EMC_s = EA_s \cap EMC_p$

*Example*  $EMC_{S1.1} = \emptyset$   
 $EMC_{S1.2} = \{I3, I4\}$   
 $EMC_{S2.1} = EMC_{S2.2} = EMC_{S2.3} = \emptyset$   
 $EMC_{S3.1} = \{I6\}$   
 $EMC_{S3.2} = \{I1\}$

As soon as the transformations are developed, the semantic interoperability has been achieved to consume the CIM elements required. The understanding of which transformations have been developed so far is provided by the set of system elements mapped for consumption by a system, depicted in the following table. This set is designated by ‘RMC’, followed by the designation of the system considered. Considering our scenario, we can see, for example, that, in the case of system S1.2, all the necessary transformation have already been defined. Likewise, for system S1.1, no transformations have been defined, which is fine, considering that none of the CIM elements this system implements (i.e. I1 and I2) are required by P1.

**Table 30:** System elements mapped for consumption

<i>Name</i>	<i>System elements mapped for consumption by a system (RMC<sub>s</sub>)</i>
<i>Informal definition</i>	Set of all system elements which mappings to consume the corresponding CIM elements have been defined
<i>Formal definition</i>	$\forall i \in \mathbb{N}, \forall s \in S, \forall a \in EMC_s$ $RMC_s = \bigcup_{i=1}^{ EMC_s } g_s(a_i)$
<i>Example</i>	$RMC_{S1.1} = \emptyset$ $RMC_{S1.2} = \{S1.2_{I3}, S1.2_{I4}\}$ $RMC_{S2.1} = \emptyset$ $RMC_{S2.2} = \emptyset$ $RMC_{S2.3} = \emptyset$ $RMC_{S3.1} = \{S3.1_{I6}\}$



$$RMC_{S3.2} = \{S3.2_{11}\}$$

**Source:** Author

To consume all the CIM elements a participant requires, it has to implement semantic interoperability in all its involved systems. The set of all systems elements, across all its systems, where semantic interoperability to consume CIM elements has been implemented, is depicted in the following table. It is designated by ‘RMC’ and followed by the designation of the participant considered. According to our scenario, for example P1 has already developed the necessary semantic interoperability to consume I3 and I4 from other participants, such as P2, while P2 has not developed semantic interoperability to consume CIM elements, because it does not require any.

**Table 31:** System elements mapped for consumption by a participant

<i>Name</i>	<i>System elements mapped for consumption by a participant (<math>RMC_p</math>)</i>
<i>Informal definition</i>	Set of all information elements, from all the participant systems, which mappings to consume the corresponding CIM elements have been defined
<i>Formal definition</i>	$\forall i \in \mathbb{N}, \forall s \in S_p, \forall p \in P$ $RMC_p = \bigcup_{i=1}^{ S_p } RMC_{S_i}$
<i>Example</i>	$RMC_{p1} = \{S1.2_{13}; S1.2_{14}\}$ $RMC_{p2} = \emptyset$ $RMC_{p3} = \{S3.1_{16}; S3.2_{11}\}$

**Source:** Author

### 5.1.9 Information to be provided

An important facet of any information exchange initiative is that of the information provisioning, which can have three different dimensions: 1) the ‘information that can be provided’, which is based on the information availability; 2) the ‘information that should be provided’, which is based on the information requirements of the other participants, and 3) the ‘information that must be provided’, which is based on the existing information transformations that semantically enable the systems to provide CIM elements to other systems.

These dimensions enable assessing the semantic interoperability performance. While the ‘information that can be provided’ dimension establishes a baseline, comprising what is theoretically possible to accomplish, the other two dimensions enable determining the performance from the information provisioning point of view. The ‘information that should be provided’ dimension enables the determination of the potential performance, and the ‘information that must be provided’ dimension

enables the determination of the actual performance.

**Figure 24:** Relationship of the different dimensions (example)

**Source:** Author

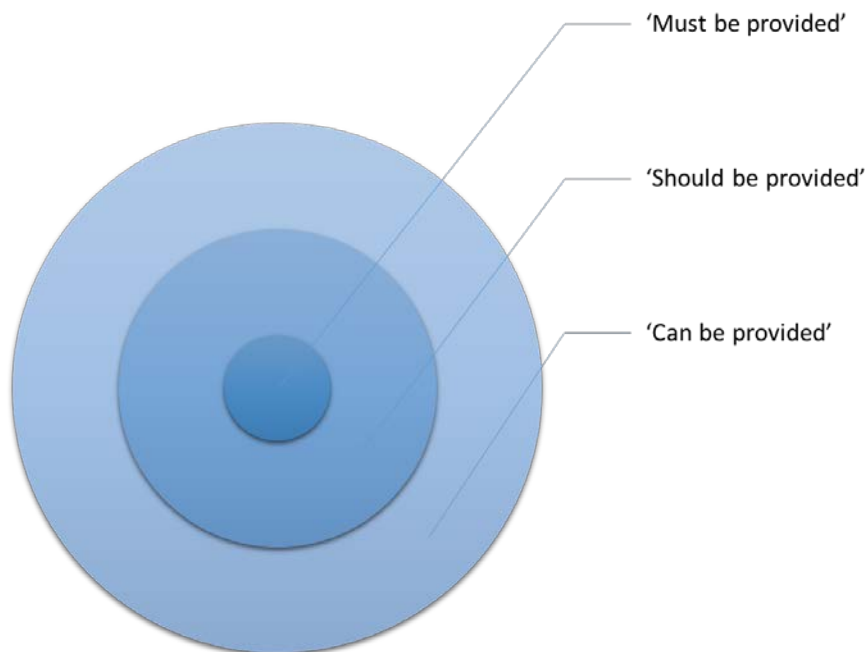

Typically, as depicted in the figure above, the information elements of one dimension are a subset of the information elements of the previous dimension. However, in an ideal scenario, the semantic interoperability is fully established, and hence the dimensions 'information that must be provided' and

'information that should be provided' coincide. As such, they contain the same information elements, and so have the same size, corresponding to a 100% performance.

In any case, the performance, potential or actual, can be assessed from different perspectives, depending on the context. On the one hand, it can be determined at the system or at the participant level and, on the other hand, it can be determined considering either the CIM elements or the system elements that implement them. While the assessment at the participant level is an aggregation of the assessment at the system level and the decision on which to use depends on the level of detail required, the assessment using the CIM elements differs from that using the system elements. The first represents the situation from the CIM point of view, making it more suitable for high-level decision making and planning involving multiple stakeholders, and the second represents the systems point of view, which is more suitable for detailed decision making and planning by a single stakeholder. Either way, the performance results must be the same.

**Figure 25:** Relationship of the performance assessed at different levels (example)

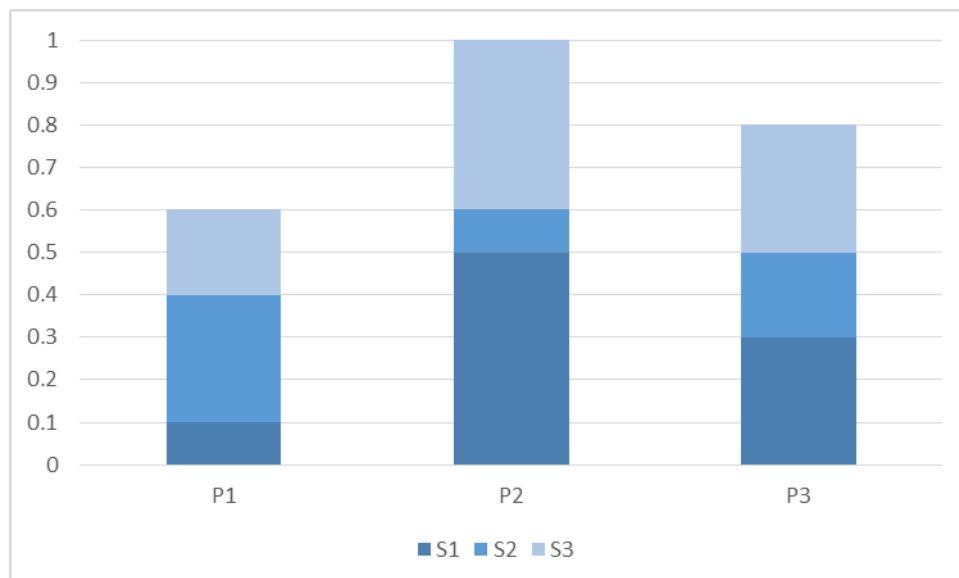

**Source:** Author

#### 5.1.9.1 Information that could be provided (baseline)

The CIM elements that could be provided by a system do not have to be exactly the same available in the system, since they also have to be implemented at least in the system of another participant. The set containing these CIM elements is designated by 'ECP', followed by the designation of the system considered, as depicted in the following table.

**Table 32:** CIM elements that could be provided by a system

<i>Name</i>	<i>CIM elements that could be provided by a system (ECP<sub>s</sub>)</i>
<b>Informal definition</b>	Set of the CIM elements: <ul style="list-style-type: none"> <li>- available (implemented) in the system;</li> <li>- available (implemented) in at least a system of another participant</li> </ul>
<b>Formal definition</b>	$\forall i \in \mathbb{N}, \forall s \in S, \forall k \in S \setminus s$ $ECP_s = EA_s \cap (\bigcup_{i=1}^{ S \setminus s } EA_{k_i})$
<b>Example</b>	$ECP_{S1.1} = \{I1, I2\}$ $ECP_{S1.2} = \{I1, I3, I4\}$ $ECP_{S2.1} = \{I4, I5, I6\}$ $ECP_{S2.2} = \{I1, I2\}$ $ECP_{S2.3} = \{I3\}$ $ECP_{S3.1} = \{I5, I6\}$ $ECP_{S3.2} = \{I1\}$

**Source:** Author

Consequently, the set of CIM elements that could be provided by a participant, is the collection of all the CIM elements that could be provided by all its systems. This set of CIM elements is designated by ‘ECP’, followed by the designation of the participant considered. As we can see from our scenario, the CIM elements that could be provided by participant P1 are those that could be provided by all its systems (i.e. S1.1 and S1.2), that is I1, I2, I3 and I4.

**Table 33:** CIM elements that could be provided by a participant

<b>Name</b>	<b>CIM elements that could be provided by a participant (<math>ECP_p</math>)</b>
<b>Informal definition</b>	Set of the CIM elements: <ul style="list-style-type: none"> <li>- available (implemented) in all the systems of the participant;</li> <li>- available (implemented) in in at least a system of another participant</li> </ul>
<b>Formal definition</b>	$\forall p \in P, \forall i \in \mathbb{N}, \forall s \in S_p$ $ECP_p = \bigcup_{i=1}^{ S_p } ECP_{S_i}$
<b>Example</b>	$ECP_{P_1} = \{I1, I1, I2, I3, I4\}$ $ECP_{P_2} = \{I1, I2, I3, I4, I5, I6\}$ $ECP_{P_3} = \{I1, I5, I6\}$

**Source:** Author

But CIM elements are implemented by system elements, so it is also important to understand which are the system elements implied by the CIM elements that could be provided. Therefore, the system elements that could provide CIM elements to other systems are those system elements that implement CIM elements that could be provided by the system. The set of these elements, depicted in the following table, is designated by ‘RCP’, followed by the designation of the system considered. Consequently, for example, according to our scenario, the system elements in system S1.1 that could provide information to other systems are those that implement CIM elements that could be provided by it (i.e. I1 and I2), specifically, S1.1<sub>I1</sub> and S1.1<sub>I2</sub>.

**Table 34:** System elements that could provide information to other systems

<i>Name</i>	<i>System elements that could be provided by a system (RCP<sub>s</sub>)</i>
<i>Informal definition</i>	Set of all system elements which implement CIM information elements
<i>Formal definition</i>	$\forall i \in \mathbb{N}, \forall s \in S, \forall a \in ECP_s$ $RCP_s = \bigcup_{i=1}^{ ECP_s } g_s(a_i)$
<i>Example</i>	$RCP_{S1.1} = \{S1.1_{11}, S1.1_{12}\}$ $RCP_{S1.2} = \{S1.2_{11}, S1.2_{13}, S1.2_{14}\}$ $RCP_{S2.1} = \{S2.1_{14}, S2.1_{15}, S2.1_{16}\}$ $RCP_{S2.2} = \{S2.2_{11}, S2.2_{12}\}$ $RCP_{S2.3} = \{S2.3_{13}\}$ $RCP_{S3.1} = \{S3.1_{15}, S3.1_{16}\}$ $RCP_{S3.2} = \{S3.2_{11}\}$

**Source:** Author

Likewise, the collection of system elements in all the systems of the participant that could provide information to other systems, is the set of system elements of the participant that could provide information to other systems. As such, this set of system elements is designated by ‘RCP’, followed by the designation of the participant considered. As depicted in the following table, and considering our scenario, the system elements of participant P1 that could provide information to the systems of other participants is composed by S1.1<sub>11</sub>, S1.1<sub>12</sub>, S1.2<sub>11</sub>, S1.2<sub>13</sub>, S1.2<sub>14</sub>.

**Table 35:** Participant systems' elements that could provide information to other systems

<b>Name</b>	<b><i>Participant systems' elements that could provide information to other systems (RCP<sub>p</sub>)</i></b>
<b>Informal definition</b>	Set comprising all the participant systems' information elements which implement CIM information elements
<b>Formal definition</b>	$\forall s \in S_p, \forall p \in P, \forall i \in \mathbb{N}$ $RCP_p = \bigcup_{i=1}^{ S_p } RCP_{s_i}$
<b>Example</b>	$RCP_{p_1} = \{S1.1_{I1}, S1.1_{I2}, S1.2_{I1}, S1.2_{I3}, S1.2_{I4}\}$ $RCP_{p_2} = \{S2.1_{I4}, S2.1_{I5}, S2.1_{I6}, S2.2_{I1}, S2.2_{I2}, S2.3_{I3}\}$ $RCP_{p_3} = \{S3.1_{I5}, S3.1_{I6}, S3.2_{I1}, S3.2_{I7}\}$

**Source:** Author

#### 5.1.9.2 Information that should be provided (potential performance)

The CIM elements that should be provided by a system are those implemented in the system, implemented in at least the system of another participant and required by it. The set of these elements is depicted in the following table. It is designated by ESP, followed by the designation of the system considered. For example, in the information sharing scenario, system S1.1 implements the CIM elements I1 and I2. Participant P3 requires I1 and implements it in system S3.2. Therefore, system S1.1 should provide I1 to be consumed by S3.2.

**Table 36:** CIM elements that should be provided by a system

<b>Name</b>	<b><i>CIM elements that should be provided by a system (ESP<sub>s</sub>)</i></b>
<b>Informal definition</b>	Set of all CIM elements that are: - available (implemented) in the system; - available (implemented) in at least one system of another participant - required by the participants that already implement them in their systems
<b>Formal definition</b>	$\forall i \in \mathbb{N}, \forall s \in S, \forall k \in S \setminus s$ $ESP_s = ECP_s \cap (\bigcup_{i=1}^{ S \setminus s } ER_{k_i})$
<b>Example</b>	$ESP_{S1.1} = \{I1\}; ESP_{S1.2} = \{I1\}$ $ESP_{S2.1} = \{I4, I5, I6\}; ESP_{S2.2} = \{I1\}; ESP_{S2.3} = \{I3\}$ $ESP_{S3.1} = \emptyset; ESP_{S3.2} = \emptyset$

**Source:** Author

The CIM elements that should be provided by a participant are those implemented in its systems that are required by other participants and implemented in their systems. In other words, it is the set of CIM elements that should be provided by all the systems of the participant. The set of these elements is depicted in the following table. It is designated by ESP, followed by the designation of the participant considered. For example, in the information sharing scenario, system S2.1 should provide I4, I5 and I6, system S2.2 should provide I1 and system S2.3 should provide I3, so participant P2 should provide all these CIM elements.

**Table 37:** System elements that should be provided by a participant

<i>Name</i>	<i>CIM elements that should be provided by a participant (ESP<sub>p</sub>)</i>
<i>Informal definition</i>	Set of all CIM elements that are: <ul style="list-style-type: none"> <li>- available (implemented) in the systems of the participant;</li> <li>- available (implemented) in at least one system of another participant</li> <li>- required by the participants that already implement them in their systems</li> </ul>
<i>Formal definition</i>	$\forall p \in P, \forall i \in \mathbb{N}, \forall s \in S_p$ $ESP_p = \bigcup_{i=1}^{ S_p } ESP_{s_i}$
<i>Example</i>	$ESP_{P1} = \{I1\}$ $ESP_{P2} = \{I1, I3, I4, I5, I6\}$ $ESP_{P3} = \emptyset$

**Source:** Author

The system elements that should be provided by a system are those that implement CIM elements, where the CIM elements implemented are also required and implemented by at least another participant. The set of these elements is depicted in the following table. It is designated by RSP, followed by the designation of the system considered. For example, in the information sharing scenario, system S1.1 should provide the CIM element I1, which in practice means it should provide its implementation that is S1.1<sub>I1</sub>. The system element S1.1<sub>I1</sub> implements the CIM element I1, which is also required and implemented by participant P3 in system S3.2, through the system element S3.2<sub>I1</sub>.



**Table 38:** System elements that should be provided

<i>Name</i>	<i>System elements that should be provided by a system (RSP<sub>s</sub>)</i>
<i>Informal definition</i>	Set of all system elements: <ul style="list-style-type: none"> <li>- that implement a CIM element in the system</li> <li>- where the CIM element implemented is also implemented by at least another participant</li> <li>- where the CIM element implemented is required by the participants that already implement it in their systems</li> </ul>
<i>Formal definition</i>	$\forall s \in S, \forall a \in ESP_s, \forall i \in \mathbb{N}$ $RSP_s = \bigcup_{i=1}^{ ESP_s } g_s(a_i)$
<i>Example</i>	$RSP_{S1.1} = \{S1.1_{I1}\}; RSP_{S1.2} = \{S1.2_{I1}\}$ $RSP_{S2.1} = \{S2.1_{I4}, S2.1_{I5}, S2.1_{I6}\}; RSP_{S2.2} = \{S2.2_{I1}\}; RSP_{S2.3} = \{S2.3_{I3}\}$ $RSP_{S3.1} = \emptyset; RSP_{S3.2} = \emptyset$

**Source:** Author

The system elements that should be provided by a participant are those that implement CIM elements in its systems, where the CIM elements implemented are also required and implemented by at least another participant. In other words, it is the set of CIM elements that should be provided by all the systems of the participant. The set of these elements is depicted in the following table. It is designated by RSP, followed by the designation of the participant considered. For example, participant P1 should provide S1.1<sub>I1</sub> from its system S1.1, and S1.2<sub>I1</sub> from its system S1.2.

**Table 39:** System elements that should be provided by a participant

<i>Name</i>	<i>System elements that should be provided by a participant (RSP<sub>p</sub>)</i>
<i>Informal definition</i>	Set of all system elements: <ul style="list-style-type: none"> <li>- that implement a CIM element in the systems of the participant</li> <li>- where the CIM element implemented is also implemented by at least another participant</li> <li>- where the CIM element implemented is required by the participants that already implement it in their systems</li> </ul>
<i>Formal definition</i>	$\forall p \in P, \forall i \in \mathbb{N}, \forall s \in S_p$ $RSP_p = \bigcup_{i=1}^{ S_p } RSP_{S_i}$
<i>Example</i>	$RSP_{p1} = \{S1.1_{I1}, S1.2_{I1}\}$ $RSP_{p2} = \{S2.1_{I4}, S2.1_{I5}, S2.1_{I6}, S2.2_{I1}, S2.3_{I3}\}$ $RSP_{p3} = \emptyset$

**Source:** Author

### 5.1.9.3 Information that must be provided (actual performance)

The CIM elements that must be provided by a system are all the CIM elements that are implemented in the system, that are required by at least another participant and implemented in at least one of its systems, and which transformations to provide them have been defined. In other words, these are the CIM elements that should be provided by a system and which transformations to provide them have been defined. The set of these elements is depicted in the following table. It is designated by EHP, followed by the designation of the system considered. For example, in the information exchange scenario, I1 should be provided by system S1.2. This CIM element is implemented in the system, is required and implemented by participant P3, in its system S3.2, through its element S3.2<sub>I1</sub>. Moreover, the transformation necessary to provide I1 from S1.2<sub>I1</sub> is defined by f<sub>I1</sub>(S1.2<sub>I1</sub>).

**Table 40:** CIM elements that must be provided by a system

<i>Name</i>	<i>CIM elements that must be provided by a system (<math>EHP_S</math>)</i>
<i>Informal definition</i>	Set of all CIM elements that: <ul style="list-style-type: none"> <li>- are available (implemented) in the system;</li> <li>- are available (implemented) in at least one system of another participant</li> <li>- are required by the participants that already implement it in their systems</li> <li>- the transformations to provide them from this system have been defined</li> </ul>
<i>Formal definition</i>	$\forall s \in S$ $EHP_S = ESP_S \cap EMP_S$
<i>Example</i>	$EHP_{s1,1} = EHP_{s2,1} = EHP_{s2,2} = EHP_{s2,3} = EHP_{s3,1} = EHP_{s3,2} = \emptyset$ $EHP_{s1,2} = I1$

**Source:** Author

The CIM elements that must be provided by a participant are all the CIM elements that are implemented in its systems, that are required by at least another participant and implemented in at least one of its systems, and which transformations to provide them have been defined. In other words, these are the CIM elements that must be provided by all the systems of the participant. The set of these elements is depicted in the following table. It is designated by EHP, followed by the designation of the participant considered. For example, in the information exchange scenario, I1 must be provided by participant P1 and it is its only CIM element in these conditions.

**Table 41:** CIM elements that must be provided by a participant

<i>Name</i>	<i>CIM elements that must be provided by a participant (<math>EHP_P</math>)</i>
<i>Informal definition</i>	Set of all CIM elements that: <ul style="list-style-type: none"> <li>- are available (implemented) in the systems of the participant;</li> <li>- are available (implemented) in at least one system of another participant</li> <li>- are required by the participants that already implement it in their systems</li> <li>- the transformations to provide them from the systems where they are implemented have been defined</li> </ul>
<i>Formal definition</i>	$\forall p \in P, \forall s \in S_p, \forall i \in \mathbb{N}$ $EHP_p = \bigcup_{i=1}^{ S_p } EHP_{s_i}$
<i>Example</i>	$EHP_{p1} = I1$ $EHP_{p2} = \emptyset$ $EHP_{p3} = \emptyset$

**Source:** Author

The system elements that must be provided by a system are all those that implement a CIM element, which CIM element is implemented and required by at least another participant and which transformations to provide it have been defined. In other words, these are the CIM elements that should be provided by a system which transformations to provide them have been implemented. The set of these elements is depicted in the following table. It is designated by RHP, followed by the designation of the system considered. For example,  $S1.2_{I1}$  is the system element that must be provided by system S1.2. It implements I1, which is required and implemented by participant P3 in its system S3.2, through its element S3.2<sub>I1</sub>. Moreover, the transformation necessary to provide I1 from  $S1.2_{I1}$  is defined by  $f_{I1}(S1.2_{I1})$ .

**Table 42:** System elements that must be provided by a system

<i>Name</i>	<i>System elements that must be provided by a system (RHP<sub>s</sub>)</i>
<i>Informal definition</i>	Set of all system elements in the system: - that implement a CIM element - which CIM element implemented is implemented by at least another participant - which CIM element implemented is required by the participants implement it - which transformations to provide it have been defined
<i>Formal definition</i>	$\forall s \in S$  $RHP_s = RSP_s \cap RMP_s$
<i>Example</i>	$RHP_{S1.1} = RHP_{S2.1} = RHP_{S2.2} = RHP_{S2.3} = RHP_{S3.1} = RHP_{S3.2} = \emptyset$ $RHP_{S1.2} = S1.2_{I1}$

**Source:** Author

The system elements that must be provided by a participant are all those that implement a CIM element in its systems, which CIM element is implemented and required by at least another participant and which transformations to provide it have been defined. In other words, these are the CIM elements that must be provided by all the systems of the participant. The set of these elements is depicted in the following table. It is designated by EHP, followed by the designation of the participant considered. For example,  $S1.2_{I1}$  is the only system element that must be provided by all the systems of participant P1, in the information exchange scenario.

**Table 43:** System elements that must be provided by a participant

<i>Name</i>	<i>System elements that must be provided by a participant (RHP<sub>p</sub>)</i>
<i>Informal definition</i>	Set of all system elements in the systems of the participant: <ul style="list-style-type: none"> <li>- that implement a CIM element</li> <li>- which CIM element implemented is implemented by at least another participant</li> <li>- which CIM element implemented is required by the participants implement it</li> <li>- which transformations to provide it have been defined</li> </ul>
<i>Formal definition</i>	$\forall p \in P, \forall i \in \mathbb{N}, \forall s \in S_p$ $RHP_p = \bigcup_{i=1}^{ S_p } RHP_{S_i}$
<i>Example</i>	$RHP_{P1} = \{S1.2_{I1}\}$ $RHP_{P2} = \emptyset$ $RHP_{P3} = \emptyset$

**Source:** Author

### 5.1.10 Information to be consumed

An important facet of any information exchange initiative is that of the information consumption, which can have three different dimensions: 1) the ‘information that could be consumed’, which is based on the information availability; 2) the ‘information that should be consumed’, which is based on the information requirements of the participant, and 3) the ‘information that must be consumed’, which is based on the existing information transformations that semantically enable the systems to consume CIM elements from other systems.

These dimensions enable assessing the semantic interoperability performance. While the ‘information that could be consumed’ dimension establishes a baseline, comprising what is theoretically possible to accomplish, the other two dimensions enable determining the performance from the information consumption point of view. The ‘information that should be consumed’ dimension enables the determination of the potential performance, and the ‘information that must be consumed’ dimension enables the determination of the actual performance.

Typically, as depicted in the following figure, the information elements of one dimension are a subset of the information elements of the previous dimension. However, in an ideal scenario the semantically interoperability is fully established, and hence the dimensions ‘information that must be consumed’ and ‘information that should be consumed’ coincide. As such, they contain the same information elements, and so have the same size, corresponding to a 100% performance.

**Figure 26:** Relationship of the different consumption dimensions (example)

**Source:** Author

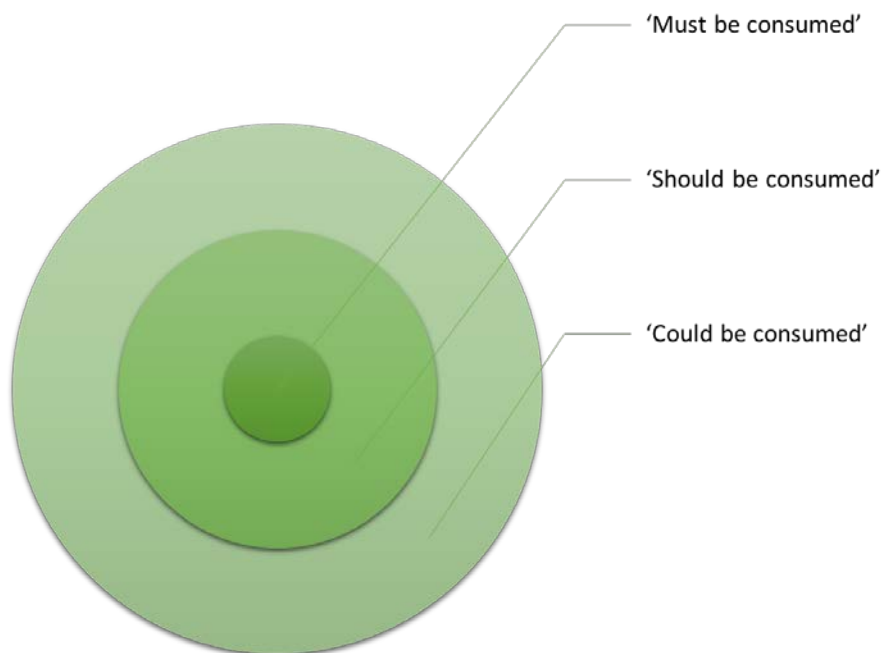

In any case, the performance, potential or actual, can be assessed from different perspectives, depending on the context. On the one hand, it can be determined at the system or at the participant level and, on the other hand, it can be determined considering either the CIM elements or the system elements that implement them. While the assessment at the participant level is an aggregation of the assessment at the

system level and the decision on which to use depends on the level of detail required, the assessment using the CIM elements differs from that using the system elements. The first represents the situation from the CIM point of view, making it more suitable for high-level decision making and planning involving multiple stakeholders, and the second represents the systems point of view, which is more suitable for detailed decision making and planning by a single stakeholder. Either way, the performance results must be the same.

**Figure 27:** Relationship of the performance assessed at different consumption levels (example)

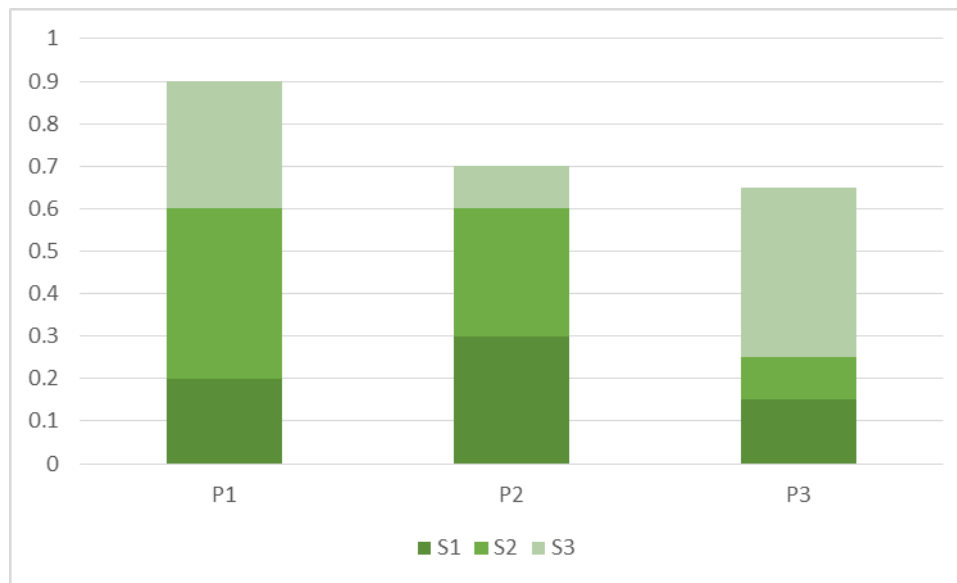

**Source:** Author

#### 5.1.10.1 Information that could be consumed (baseline)

The CIM elements that could be consumed by a system are those implemented in a particular system and in at least a system of another participant. The set of these elements is depicted in the following table. It is designated by ECC, followed by the designation of the system considered. For example, in the information exchange scenario, system S3.2 implements the CIM elements I1 and I7. Therefore, S3.2 cannot consume any CIM element other than those two. On the other hand, because the other systems do not implement I7, the CIM elements S3.2 can only consume I1.

**Table 44:** CIM elements that could be consumed by a system

<i>Name</i>	<i>CIM elements that could be consumed by a system (ECC<sub>s</sub>)</i>		
<i>Informal definition</i>	Set of all CIM elements that: <ul style="list-style-type: none"> <li>- are available in the system</li> <li>- are available in at least a system of another participant</li> </ul>		
<i>Formal definition</i>	$\forall i \in \mathbb{N}, \forall s \in S, \forall k \in S \setminus s$ $ECC_S = EA_s \cap \left( \bigcup_{i=1}^{ S \setminus s } EA_{k_i} \right)$		
<i>Example</i>	$ECC_{S1.1} = \{I1, I2\}$ $ECC_{S1.2} = \{I1, I3, I4\}$	$ECC_{S2.1} = \{I4, I5, I6\}$ $ECC_{S2.2} = \{I1, I2\}$ $ECC_{S2.3} = \{I3\}$	$ECC_{S3.1} = \{I5, I6\}$ $ECC_{S3.2} = \{I1\}$

**Source:** Author

The CIM elements that could be consumed by a participant are those implemented in all its systems and in at least a system of another participant. In other words, it is the set of all the CIM elements that could be consumed by all its systems. This set is depicted in the following table. It is designated by ECC, followed by the designation of the participant considered. For example, in the information exchange scenario, participant P3 implements the CIM elements I1, I5, I6 and I7. Since I7 is the only not implemented by any other participant, P3 could consume the CIM elements I1, I5 and I6. In the information exchange scenario, we can also see that participant P1 could consume I1 from P2 (S2.2) and P3 (S3.2), so we need to consider two different instances of I1 because the semantic interoperability needs to be implemented between both systems and the CIM.



**Table 45:** CIM elements that could be consumed by a participant

<i>Name</i>	<i>CIM elements that could be consumed by a participant (ECC<sub>P</sub>)</i>
<i>Informal definition</i>	Set of all CIM elements that: <ul style="list-style-type: none"> <li>- are available in the systems of the participant</li> <li>- are available in at least a system of another participant</li> </ul>
<i>Formal definition</i>	$\forall i \in \mathbb{N}, \forall p \in P, \forall s \in S_p$ $ECC_P = \bigcup_{i=1}^{ S_p } ECC_{S_i}$
<i>Example</i>	$ECC_{P1} = \{I1, I1, I2, I3, I4\}$ $ECC_{P2} = \{I1, I2, I3, I4, I5, I6\}$ $ECC_{P3} = \{I1, I5, I6\}$

**Source:** Author

The system elements that could consume information from another system are those which corresponding CIM elements are implemented in the system considered and in the systems of other participants involved in the exchange of information. The set of these elements is depicted in the following table. It is designated by RCC, followed by the designation of the system considered. For example, in the information sharing scenario, system S1.1 implements the CIM elements I1 and I2 in system elements S1.1<sub>I1</sub> and S1.1<sub>I2</sub>, respectively. Since those CIM elements are also implemented by participant P2 in system S2.2 and I1 is also implemented by P3 in system S3.2, then I1 and I2 can be consumed from the systems of other participants and, consequently, the system elements of P1 that could consume I1 and I2 from other systems are S1.1<sub>I1</sub> and S1.1<sub>I2</sub>.

**Table 46:** System elements that could consume from other systems

<i>Name</i>	<i>System elements that could consume from other systems (RCC<sub>s</sub>)</i>
<i>Informal definition</i>	Set of all system's elements: - that implement a CIM element  - which CIM element implemented is also implemented by at least another participant
<i>Formal definition</i>	$\forall s \in S, \forall a \in ECC_s, \forall i \in \mathbb{N}$ $RCC_s = \bigcup_{i=1}^{ ECC_s } g_s(a_i)$
<i>Example</i>	$RCC_{S1.1} = \{S1.1_{11}, S1.1_{12}\}$ $RCC_{S1.2} = \{S1.2_{11}, S1.2_{13}, S1.2_{14}\}$ $RCC_{S2.1} = \{S2.1_{14}, S2.1_{15}, S2.1_{16}\}$ $RCC_{S2.2} = \{S2.2_{11}, S2.2_{12}\}$ $RCC_{S2.3} = \{S2.3_{13}\}$ $RCC_{S3.1} = \{S3.1_{15}, S3.1_{16}\}$ $RCC_{S3.2} = \{S3.2_{11}\}$

**Source:** Author

The system elements of a participant that could consume from other systems are those which corresponding CIM elements are implemented in the systems of the participant considered and in the systems of other participants involved in the exchange of information. In other words, it is the collection of the system elements of the participant that could consume information from the systems of other participants. The set of these elements is depicted in the following table. It is designated by RCC, followed by the designation of the participant considered. For example, in the information sharing scenario, the system elements that could be consumed by participant P1 is the collection of the system elements that could be consumed by its systems S1.1 and S1.2, which in this case means S1.1<sub>11</sub>, S1.1<sub>12</sub>, S1.2<sub>11</sub>, S1.2<sub>13</sub> and S1.2<sub>14</sub>.

**Table 47:** Participant systems' elements that could consume from other systems

<i>Name</i>	<i>Participant systems' elements that could consume from other systems (<math>RCC_p</math>)</i>
<i>Informal definition</i>	Set comprising all the system elements of a participant: - that implement a CIM element - which CIM element implemented is also implemented by at least another participant
<i>Formal definition</i>	$\forall p \in P, \forall i \in \mathbb{N}, \forall s \in S_p$ $RCC_p = \bigcup_{i=1}^{ S_p } RCC_{S_i}$
<i>Example</i>	$RCC_{P1} = \{S1.1_{I1}, S1.1_{I2}, S1.2_{I1}, S1.2_{I3}, S1.2_{I4}\}$ $RCC_{P2} = \{S2.1_{I4}, S2.1_{I5}, S2.1_{I6}, S2.2_{I1}, S2.2_{I2}, S2.3_{I3}\}$ $RCC_{P3} = \{S3.1_{I5}, S3.1_{I6}, S3.2_{I1}\}$

**Source:** Author

#### 5.1.10.2 Information that should be consumed (potential performance)

The CIM elements that should be consumed by a system are those the participant requires that are implemented in the system considered and also in the systems of the other participants. In other words, they are the CIM elements that could be consumed by a system that are also required by the participant. The set of these elements is depicted in the following table. It is designated by ESC, followed by the designation of the system considered. For example, in the information sharing scenario, although system S1.2 could consume the CIM elements I1, I3 and I4, it should only consume I3 and I4, because these are the only ones the participant P1 requires.

**Table 48:** CIM elements that should be consumed by a system

<i>Name</i>	<i>CIM elements that should be consumed by a system (ESC<sub>s</sub>)</i>
<i>Informal definition</i>	Set of all CIM elements that: <ul style="list-style-type: none"> <li>- are available (implemented) in the system;</li> <li>- are available (implemented) in at least one system of another participant</li> <li>- is required by the participant</li> </ul>
<i>Formal definition</i>	$\forall i \in \mathbb{N}, \forall s \in S, \forall k \in S \setminus s$ $ESC_s = ECC_s \cap \left( \bigcup_{i=1}^{ S \setminus s } ER_{k_i} \right)$
<i>Example</i>	$ESC_{S1.2} = \{I3, I4\}$ $ESC_{S3.1} = \{I5, I6\}$ $ESC_{S3.2} = \{I1\}$ $ESC_{S1.1} = ESC_{S2.1} = ESC_{S2.2} = ESC_{S2.3} = \emptyset$

**Source:** Author

The CIM elements that should be consumed by a participant are those he requires that are implemented in its systems and in the systems of other participants. In other words, they are the CIM elements that could be consumed and which are required by the participant. The set of these elements is depicted in the following table. It is designated by ESC, followed by the designation of the participant considered. For example, in the information exchange scenario, although participant P1 could consume the CIM elements I1, I2, I3 and I4, he should only consume I3 and I4, because these are the only ones he requires.

**Table 49:** CIM elements that should be consumed by a participant

<i>Name</i>	<i>CIM elements that should be consumed by a participant (<math>ESC_p</math>)</i>
<i>Informal definition</i>	Set of all CIM elements that : <ul style="list-style-type: none"> <li>- are available (implemented) in the participant systems;</li> <li>- are available (implemented) in at least one system of another participant</li> <li>- are required by the participant</li> </ul>
<i>Formal definition</i>	$\forall p \in P, \forall i \in \mathbb{N}, \forall s \in S_p$ $ESC_p = \bigcup_{i=1}^{ S_p } ESC_{S_i}$
<i>Example</i>	$ESC_{P1} = \{I3, I4\}$ $ESC_{P2} = \emptyset$ $ESC_{P3} = \{I1, I5, I6\}$

**Source:** Author

The system elements that should consume from other systems are those which corresponding CIM elements are required by the participant, implemented in the system considered and in systems of other participants involved in the exchange of information. In other words, these are system elements that could consume from other systems and which corresponding CIM elements are required by the participant. The set of these elements is depicted in the following table. It is designated by RSC, followed by the designation of the system considered. For example, in the information sharing scenario, the system elements of S3.1 that could consume from other systems are S3.1<sub>I5</sub> and S3.1<sub>I6</sub>. Since these system elements implement the CIM elements I5 and I6 that are required by P3, then S3.1<sub>I5</sub> and S3.1<sub>I6</sub> are also the system elements that should consume from other systems.

**Table 50:** System elements that should be consumed by a system

<i>Name</i>	<i>System elements that should consume from other systems (RSC<sub>s</sub>)</i>	
<i>Informal definition</i>	Set of the system elements : - that implement a CIM element - which CIM element implemented is also implemented by at least another participant - which CIM element implemented is required by the participant	
<i>Formal definition</i>	$\forall s \in S, \forall a \in ESC_s, \forall i \in \mathbb{N}$ $RSC_s = \bigcup_{i=1}^{ ESC_s } g_s(a_i)$	
<i>Example</i>	$RSC_{S1.1} = \emptyset$ $RSC_{S1.2} = \{S1.2_{13}, S1.2_{14}\}$ $RSC_{S2.1} = \emptyset$ $RSC_{S2.2} = \emptyset$	$RSC_{S2.3} = \emptyset$ $RSC_{S3.1} = \{S3.1_{15}, S3.1_{16}\}$ $RSC_{S3.2} = \{S3.2_{11}\}$

**Source:** Author

The system elements of the participant that should consume from other systems are those which corresponding CIM elements are required by it, implemented in its systems and in the systems of other participants involved in the exchange of information. In other words, it is the collection of the system elements of the participant that should consume information from the systems of other participants. The set of these elements is depicted in the following table. It is designated by RSC, followed by the designation of the participant considered.

**Table 51:** System elements that should be consumed by a participant

<i>Name</i>	<i>Participant systems' elements that should consume from other systems (RSC<sub>p</sub>)</i>
<i>Informal definition</i>	Set of the participant systems' elements: - that implement a CIM element - which CIM element implemented is also implemented by at least another participant - which CIM element implemented is required by the participant
<i>Formal definition</i>	$\forall p \in P, \forall i \in \mathbb{N}, \forall s \in S_p$ $RSC_p = \bigcup_{i=1}^{ S_p } RSC_{S_i}$
<i>Example</i>	$RSC_{P1} = \{S1.2_{I3}, S1.2_{I4}\}$ $RSC_{P2} = \emptyset$ $RSC_{P3} = \{S3.1_{I5}, S3.1_{I6}, S3.2_{I1}\}$

**Source:** Author

#### 5.1.10.3 Information that must be consumed (actual performance)

The CIM elements that must be consumed by a system are those that the participant requires, that are implemented in the system considered and in systems of other participants, and which transformations to consume them from the CIM have already been defined. In other words, they are the CIM elements that should be consumed by the participant, which semantic interoperability is already developed between the system considered and the CIM. The set of these elements is depicted in the following table. It is designated by EHC, followed by the designation of the system considered. For example, in the information sharing scenario, although system S3.1 should consume the CIM elements I5 and I6, I5 is not yet mapped for consumption, therefore the only element readily available for consumption is I6, which is the one that must be consumed by S3.1.

**Table 52:** CIM elements that must be consumed by a system

<i>Name</i>	<i>CIM elements that must be consumed by a system (EHC<sub>s</sub>)</i>
<i>Informal definition</i>	Set of all CIM elements: <ul style="list-style-type: none"> <li>- that are available in the system</li> <li>- that are available in at least a system of another participant</li> <li>- that are required by the participant</li> <li>- which transformations to be consumed by this system have been defined</li> </ul>
<i>Formal definition</i>	$\forall p \in P$ $EHC_s = ESC_s \cap EMC_s$
<i>Example</i>	$EHC_{S1.2} = \{I3, I4\}$ $EHC_{S3.1} = \{I6\}$ $EHC_{S3.2} = \{I1\}$ $EHC_{S1.1} = EHC_{S2.1} = EHC_{S2.2} = EHC_{S2.3} = \emptyset$

**Source:** Author

The CIM elements that must be consumed by a participant are those that it requires, that are implemented in its systems and in systems of other participants, and which transformations to consume them from the CIM have already been defined. In other words, they are the CIM elements that should be consumed by the participant, which semantic interoperability is already developed. The set of these elements is depicted in the following table. It is designated by EHC, followed by the designation of the participant considered. For example, in the information sharing scenario, participant P3 must consume the CIM elements I1 and I6, as a result of what its systems S3.2 and S3.1 must consume, respectively.



**Table 53:** CIM elements that must be consumed by a participant

<i>Name</i>	<i>CIM elements that must be consumed by a participant (<math>EHC_p</math>)</i>
<i>Informal definition</i>	Set of all CIM elements: <ul style="list-style-type: none"> <li>- that are available in the participant systems</li> <li>- that are available in at least a system of another participant</li> <li>- that are required by the participant</li> <li>- which transformations to be consumed by the respective systems have been defined</li> </ul>
<i>Formal definition</i>	$\forall p \in P, \forall i \in \mathbb{N}, \forall s \in S_p$ $EHC_p = \bigcup_{i=1}^{ S_p } EHC_{S_i}$
<i>Example</i>	$EHC_{P1} = \{I3, I4\}$ $EHC_{P2} = \emptyset$ $EHC_{P3} = \{I1, I6\}$

**Source:** Author

The system elements that must consume from other systems are those which corresponding CIM elements are required by the participant, implemented in the system considered and in other systems involved in the exchange of information, and which transformations to consume the corresponding CIM elements have been defined. In other words, these are system elements that should consume information from other systems and which semantic interoperability for that purpose has been established. The set of these elements is depicted in the following table. It is designated by RHC, followed by the designation of the system considered. For example, in the information sharing scenario, system S3.1 implements the CIM elements I5 and I6 which are also required by participant P3. Therefore, S3.1<sub>I5</sub> and S3.1<sub>I6</sub> should consume information from other systems. However, since only the transformation necessary for S3.1<sub>I6</sub> to consume I6 is defined, S3.1<sub>I6</sub> is the only system element in S3.1 that must consume information from other systems.

**Table 54:** System elements that must consume from other systems

<i>Name</i>	<i>System elements that must consume from other systems (RHC<sub>s</sub>)</i>
<i>Informal definition</i>	Set of system elements: - that implement a CIM element - which CIM element implemented is also implemented by at least another participant - which CIM element implemented is required by the participant - which transformations to consume from the CIM have been defined
<i>Formal definition</i>	$\forall s \in S$ $RHC_s = RSC_s \cap RMC_s$
<i>Example</i>	$RHC_{S1.1} = \emptyset$ $RHC_{S1.2} = \{S1.2_{13}, S1.2_{14}\}$ $RHC_{S2.1} = \emptyset$ $RHC_{S2.2} = \emptyset$ $RHC_{S2.3} = \emptyset$ $RHC_{S3.1} = \{S3.1_{16}\}$ $RHC_{S3.2} = \{S3.2_{11}\}$

**Source:** Author

The system elements that must be consumed by a participant are those which corresponding CIM elements are required by it, implemented in its systems and in the systems of the other participants in the exchange of information, and which transformations to consume the corresponding CIM elements have been defined. In other words, these are system elements that should be consumed by a participant and which semantic interoperability to consume them from the CIM has been established. The set of these elements is depicted in the following table. It is designated by MRSC, followed by the designation of the participant considered. For example, in the information sharing scenario, participant P3 must consume the system elements S1.1<sub>11</sub>, S1.2<sub>11</sub>, S2.2<sub>11</sub>, S2.1<sub>16</sub>, because these are the ones that must be consumed by its systems.

**Table 55:** Participant systems' elements that must consume from other systems

<i>Name</i>	<i>Participant systems' elements that must consume from other systems (RHC<sub>p</sub>)</i>
<i>Informal</i>	Set of system elements from all the systems of the participant :

**Source:** Author

<i>definition</i>	<ul style="list-style-type: none"> <li>- that implement a CIM element</li> <li>- which CIM element implemented is also implemented by at least another participant</li> <li>- which CIM element implemented is required by the participant</li> <li>- which transformations to consume from the CIM have been defined</li> </ul>
<i>Formal definition</i>	$\forall p \in P, \forall s \in S_p, \forall i \in \mathbb{N}$ $RHC_p = \bigcup_{i=1}^{ S_p } RHC_{s_i}$
<i>Example</i>	$RHC_{P1} = \{S1.2_{I3}, S1.2_{I4}\}$ $RHC_{P2} = \emptyset$ $RHC_{P3} = \{S3.1_{I6}, S3.2_{I1}\}$

## 5.2 Relevance

### 5.2.1 Factors, weight and relevance

Organizations decide to exchange information for several reasons, to which we generically call business factors. The set of the factors considered in an information exchange initiative is designated by ‘F’, as depicted in the following table. In our scenario, for example, we consider three business factors, named ‘F1’, ‘F2’ and ‘F3’, respectively.

**Table 56:** Factors

<i>Name</i>	<i>Factors (F)</i>
<i>Informal definition</i>	Set of all business factors for which the information contributes
<i>Formal definition</i>	$F = \{f_1, f_2, f_3, \dots, f_n\}$
<i>Example</i>	$F = \{F1, F2, F3\}$

**Source:** Author

Business factors (factors in short), do not necessarily have the same importance to the stakeholders of the process. Therefore, to cope with this requirement, we defined the factor weight, which is relative, among the several factors considered, and is designated by ‘W’, followed by the designation of the factor considered. In the scenario, for example, the weight of F1 was defined as 0.5, as depicted in the following table. There are many ways that can be used to define these weights, and the best one used will depend on the context. This is usually done by experts, and what is most important is that the total of the weights defined amounts to 1.

**Table 57:** Factor weight

<i>Name</i>	<i>Factor weight (<math>W_f</math>)</i>
<i>Informal definition</i>	Relative weight of each business factor
<i>Formal definition</i>	$W_f = \{w_1, w_2, w_3, \dots, w_n\}$
<i>Example</i>	$W_{F1} = 0.5; W_{F2} = 0.3; W_{F3} = 0.2$

**Source:** Author

The CIM element relevance is, as the name implies, the degree of importance of a CIM element to a business factor. In our framework, this is determined by experts, using a questionnaire, as we will demonstrate in the following chapters. The CIM element relevance is designated by ‘R’, followed by the designations of the CIM element and of the business factor considered. In the scenario, for example, we considered that the relevance of the CIM element I1 to the business factor F1 was of 4, in a range between 0 and 4. Again, the scale used by the experts can vary according to the context, and what is important is that the relevance is determined.

**Table 58:** CIM element relevance

<i>Name</i>	<i>CIM element relevance (<math>R_{af}</math>)</i>
<i>Informal definition</i>	Relevance of each information element to each business factor (as defined by the experts)

<i>Formal definition</i>	$R_{af} = \{r_{11F1}, r_{11F2}, r_{11F3}, \dots, r_{nm}\}$ (for each n and m...)
<i>Example</i>	$R_{11F1} = 4; R_{11F2} = 3; R_{11F3} = 2$  $R_{12F1} = 3; R_{12F2} = 2; R_{12F3} = 1$  $R_{13F1} = 2; R_{13F2} = 1; R_{13F3} = 0$  $R_{14F1} = 1; R_{14F2} = 0; R_{14F3} = 4$  $R_{15F1} = 0; R_{15F2} = 4; R_{15F3} = 3$  $R_{16F1} = 4; R_{16F2} = 3; R_{16F3} = 2$  $R_{17F1} = 3; R_{17F2} = 2; R_{17F3} = 1$

**Source:** Author

The CIM element weighed relevance is the degree of importance of a CIM element to all the business factors, considering their relative weight. It is designated by ‘WR’, followed by the designation of the CIM element considered. In the scenario, for example, the weighed relevance of the CIM element I1 is of 3.1, as depicted in the following table.

**Table 59:** CIM element weighed relevance

<i>Name</i>	<b>CIM element weighed relevance (<math>WR_a</math>)</b>
<i>Informal definition</i>	Overall relevance of a CIM element to all business factors considered
<i>Formal definition</i>	$\forall i \in \mathbb{N}, \forall a \in E_{CIM}, \forall f \in F$ $WR_a = \sum_{i=1}^{ F } (R_{afi} * W_{fi})$

*Example*  $WR_{11} = 3,1; WR_{12} = 2,3; WR_{13} = 1,3;$   
 $WR_{14} = 1,3; WR_{15} = 1,8; WR_{16} = 3,3; WR_{17} = 2,3$

### 5.2.2 Other concepts

In practice, the information systems of the organizations do not only comprise CIM elements. Therefore, it becomes necessary to identify those that do it. As such, the set of system elements of all the information systems that participate in the information exchange process, is designated by ‘AR’, as depicted in the following table. In our scenario, we only represent system elements that implement CIM elements, therefore, in this case, AR comprises all the system elements of the scenario.

**Table 60:** Systems’ elements implementing CIM elements

<i>Name</i>	<b><i>Systems’ elements implementing CIM elements (AR)</i></b>
<i>Informal definition</i>	All systems’ elements which implement CIM elements
<i>Formal definition</i>	$AR = \bigcup_{i=1}^{ S } R_i$ $\forall i \in \mathbb{N}$
<i>Example</i>	$AR = S1.1_{11}, S1.1_{12}, \dots S3.2_{17}$

**Source:** Author

All system elements are implemented in an information system. The following function enables us to find out what is the system implementing a specific system element. It is designated by ‘h’ and formalized as depicted in the following table. In the scenario, for example, the system implementing the element S1.1<sub>11</sub> is S1.1, as can be inferred from the name.

**Table 61:** System containing a system element

<i>Name</i>	<b><i>System containing a system element (h)</i></b>
<i>Informal definition</i>	System which contains a particular system element
<i>Formal definition</i>	$h(a) = s$ $\forall a \in AR, \quad \forall s \in S$
<i>Example</i>	$h(S1.1_{11}) = S1.1$

**Source:** Author

Given the information requirements and availabilities, at a certain point it becomes clear the information

that should be consumed by each of the system elements, and knowing which are specifically the system elements that will consume a given system element becomes essential. In the following table, this set of elements is designated by AC, followed by the designation of the system element that should be consumed.

**Table 62:** Systems elements that will consume a specific system element

<i>Name</i>	<i>Systems elements that should consume a specific system element (RSC<sub>r</sub>)</i>
<i>Informal definition</i>	Set of all systems' elements that should consume a specific system element
<i>Formal definition</i>	$\bigcup_{i=1}^{ S } \bigcup_{j=1}^{ RSC_i } (a \cap RSC_j)$ $\forall a \in AR, \quad \forall i, j \in \mathbb{N}$
<i>Example</i>	$RSC_{S1.1\ I1} = S3.2\ I1; RSC_{S1.1\ I2} = 0;$ $RSC_{S1.2\ I1} = S3.2\ I1; RSC_{S1.2\ I3} = 0; RSC_{S1.2\ I4} = 0;$ $RSC_{S2.1\ I4} = S1.2\ I4; RSC_{S2.1\ I5} = S3.1\ I5; RSC_{S2.1\ I6} = S3.1\ I6;$ $RSC_{S2.2\ I1} = S3.2\ I1; RSC_{S2.2\ I2} = 0;$ $RSC_{S2.3\ I3} = S1.2\ I3;$ $RSC_{S3.1\ I5} = 0; RSC_{S3.1\ I6} = 0;$ $RSC_{S3.2\ I1} = 0; RSC_{S3.2\ I7} = 0;$

**Source:** Author

Likewise, there are also a certain number of system elements that, at a certain point, must consume a specific system element, and knowing which elements are these is essential. Therefore, the set of these elements is depicted in the following table, designated by 'EHC' and followed by the designation of the element that must be consumed. In the scenario, for example, the system element S1.1<sub>I1</sub> must be consumed by the system element S3.2<sub>I1</sub>.

**Table 63:** Mapped systems elements that will consume a specific system element

<i>Name</i>	<i>Mapped systems elements that must consume a specific system element (RHC<sub>e</sub>)</i>		
<i>Informal definition</i>	Set of all mapped systems' elements that must consume a specific system element		
<i>Formal definition</i>	$\forall a \in AR$ $MAC_a \subseteq AC_a$		
<i>Example</i>	$AC_{S1.1\ I1} = S3.2\ I1$ $AC_{S1.1\ I2} = 0$ $AC_{S1.2\ I1} = S3.2\ I1$ $AC_{S1.2\ I3} = 0$	$AC_{S2.1\ I4} = S1.2\ I4$ $AC_{S2.1\ I5} = 0$ $AC_{S2.1\ I6} = S3.1\ I6$ $AC_{S2.2\ I1} = S3.2\ I1$	$AC_{S3.1\ I5} = 0$ $AC_{S3.1\ I6} = 0$ $AC_{S3.2\ I1} = 0$ $AC_{S3.2\ I7} = 0$

**Source:** Author

$$AC_{S1.2\ 14} = 0$$

$$AC_{S2.2\ 12} = 0$$

$$AC_{S2.3\ 13} = S1.2_{13}$$

Each system element belongs to a specific system which, in turn, belongs to a specific participant. It is essential to understand which participant owns a specific system element. This function is designated by 'l', followed by the designation of the system element considered. In the scenario, for example, the system element S1.1<sub>11</sub> belongs to participant P1.

**Table 64:** Participant which owns a specific system element

<b>Name</b>	<b><i>Participant which owns a specific system element (<math>l_e</math>)</i></b>
<b>Informal definition</b>	Participant which owns a specific system information element
<b>Formal definition</b>	$\forall a \in AR, \quad \forall p \in P$ $l(a) = p$
<b>Example</b>	$l(S1.1_{11}) = P1$

**Source:** Author

It is also important to understand which systems should consume a specific system element. The set that contains this information is depicted in the following table. It is designated by SSC'', followed by the designation of the system element considered. In the scenario, for example, the system that should consume the system element S1.1<sub>11</sub> is S3.2.

**Table 65:** Systems consuming a specific system element

<b>Name</b>	<b><i>Systems that should consume a specific system element (<math>SSC_e</math>)</i></b>		
<b>Informal definition</b>	Set of all systems which will consume a specific system element		
<b>Formal definition</b>	$\forall e \in ER$ $SSC_e = h(ESC_e)$		
<b>Example</b>	$CS_{S1.1\ 11} = S3.2$ $CS_{S1.1\ 12} = 0$ $CS_{S1.2\ 11} = S3.2$ $CS_{S1.2\ 13} = 0$ $CS_{S1.2\ 14} = 0$	$CS_{S2.1\ 14} = S1.2$ $CS_{S2.1\ 15} = S3.1$ $CS_{S2.1\ 16} = S3.1$ $CS_{S2.2\ 11} = S3.2$ $CS_{S2.2\ 12} = 0$ $CS_{S2.3\ 13} = S1.2$	$CS_{S3.1\ 15} = 0$ $CS_{S3.1\ 16} = 0$ $CS_{S3.2\ 11} = 0$ $CS_{S3.2\ 17} = 0$

**Source:** Author

Likewise, the information about the participants consuming a specific system element is available in the



set designated by ‘SSP’, followed by the designation of the system element to be consumed, as depicted in the following table. In the scenario, for example, the participant that should consume the system element S1.1<sub>11</sub> is participant P3.

**Table 66:** Participants consuming a specific system element

<i>Name</i>	<i>Participants that should consume a specific system element (SSP<sub>e</sub>)</i>		
<i>Informal definition</i>	Set of all participants which should consume a specific system element		
<i>Formal definition</i>	$\forall e \in ER, \quad \forall i \in \mathbb{N}$ $SSP_e = \bigcup_{i=1}^{ S } l(SSS_e)$		
<i>Example</i>	$CP_{S1.1\ 11} = P3$ $CP_{S1.1\ 12} = 0$ $CP_{S1.2\ 11} = P3$ $CP_{S1.2\ 13} = 0$ $CP_{S1.2\ 14} = 0$	$CP_{S2.1\ 14} = P1$ $CP_{S2.1\ 15} = P3$ $CP_{S2.1\ 16} = P3$ $CP_{S2.2\ 11} = P3$ $CP_{S2.2\ 12} = 0$ $CP_{S2.3\ 13} = P1$	$CP_{S3.1\ 15} = 0$ $CP_{S3.1\ 16} = 0$ $CP_{S3.2\ 11} = 0$ $CP_{S3.2\ 17} = 0$

**Source:** Author

## 6 Indicators definition

### 6.1 Performance indicators

So far, the iShare framework allowed us to characterize, in an objective way, an information sharing scenario, thereby satisfying already the needs of many of the typical stakeholders of these processes. We were able to define the information availability and requirements of each organization, and their role as information providers and consumers. Moreover, we were able to identify the information systems and attributes that must be involved, how, and the transformation functions that have to be implemented. Furthermore, based on this it becomes possible to define the changes that have to be made to the systems involved to enable them to receive the required information, and also to define a list of actions to increase the semantic interoperability of the organizations, which can be used as a baseline for an action plan to improve their semantic interoperability.

However, to properly manage those actions, it is also necessary to quantify them. And this can be

achieved by defining indicators with which it becomes possible to define baselines, establish objectives and targets, evaluate the performance and make benchmarks. Therefore, we have defined the following 10 basic indicators<sup>3</sup> which are consistent with each of the respective representation-targets defined earlier.

These indicators, which are compiled in appendix 3 for convenience, will now be defined and exemplified based on the information sharing scenario presented in appendix 1. We will define indicators at the system level only, and based only on the system elements, because this is the right level of detail to quantify semantic interoperability. Once calculated, the indicators can be aggregated at the organization, project or higher levels, if necessary. Therefore, for each of the representation-targets earlier discussed, except the one about the information needed that has no expression at the system level, we will define and explain the corresponding indicators and demonstrate their usage. The results of these indicators, after being applied to the information sharing scenario, is presented in appendix 5.

### 6.1.1 Information available

For a system to be involved in an information exchange initiative it must already implement at least one information element from the CIM that can be provided or used to consume information from the systems of the other participants. The number of systems elements available in a system is, therefore, the number of CIM information elements that the system implements. It is designated by IRA and followed by the designation of the system considered, as depicted in the following table. In our scenario, we can see that, for example, system S1.1 implements two CIM elements, I1 and I2; therefore, the number of system elements implemented in the system is 2.

**Table 67:** System elements available in a system

<i>Indicator name</i>	<i>Number of system elements available in a system (IRA<sub>s</sub>)</i>
<i>Informal definition</i>	Number of system elements available in a system
<i>Formal definition</i>	$\forall s \in S,$ $IRA_s =  RA_s $
<i>Range</i>	$\mathbb{N}_0$
<i>Scale</i>	Ratio
<i>Example</i>	$IRA_{S1.1} = 2; IRA_{S1.2} = 3;$ $IRA_{S2.1} = 3, IRA_{S2.2} = 2, IRA_{S2.3} = 1,$

**Source:** Author

<sup>3</sup> A basic indicat

2007)

$$IRA_{S3.1} = 2, IRA_{S3.2} = 2$$

### 6.1.2 Information required

According to their operational processes, participants require certain information. In some cases, although they already have it in their systems, they could still benefit from getting it from the systems of other participants as well. This is the case where participants will require information from other participants.

In this case, the number of system elements required by a system is the number of CIM elements implementations in the system that the participant requires. This is designated by IRR, followed by the designation of the system considered, as depicted in the following table. In the scenario, for example, participant P1 needs the CIM elements I3, I4 I5 and I7 for its business processes, but since only I3 and I4 are implemented in its system S1.2, the system elements implementing these CIM elements are the only ones that system S1.2 can require.

**Table 68:** System elements required by a system

<b>Indicator name</b>	<b>Number of system elements required by a system (<math>IRR_s</math>)</b>
<i>Informal definition</i>	Number of all system elements that implement CIM elements required by the participant
<i>Formal definition</i>	$\forall s \in S,$ $IRR_s =  RR_s $
<i>Range</i>	$\mathbb{N}_0$
<i>Scale</i>	Ratio
<i>Example</i>	$IRR_{S1.1} = 0; IRR_{S1.2} = 2;$ $IRR_{S2.1} = 0, IRR_{S2.2} = 0, IRR_{S2.3} = 0,$ $IRR_{S3.1} = 2, IRR_{S3.2} = 2$

**Source:** Author

### 6.1.3 Information mapped

#### 6.1.3.1 Information mapped for provisioning

The number of system elements mapped for provisioning by a system is the number of CIM elements implemented in the system, which transformations from their implementations in the system into its equivalent CIM elements have been defined by the participant. This is designated by IRMP, followed by the designation of the system considered, as depicted in the following table. In the scenario, for example, system S1.2 implements the CIM element I1, through its system element S1.2<sub>I1</sub>, which transformation function into I1 ( $f_{I1}$ ) is already defined by participant P1.

**Table 69:** System elements mapped for provisioning by a system

<b>Indicator name</b>	<b>Number of system elements mapped for provisioning by a system (<math>IRMP_s</math>)</b>
<b>Informal definition</b>	Number of system elements: - which transformations to provide the corresponding CIM elements have been defined
<b>Formal definition</b>	$\forall s \in S,$ $IRMP_s =  RMP_s $
<b>Range</b>	$\mathbb{N}_0$
<b>Scale</b>	Ratio
<b>Example</b>	$IRMP_{S1.1} = 0; IRMP_{S1.2} = 1;$ $IRMP_{S2.1} = 0, IRMP_{S2.2} = 0, IRMP_{S.3} = 0,$ $IRMP_{S3.1} = 0, IRMP_{S3.2} = 0$

**Source:** Author

### 6.1.3.2 Information mapped for consumption

The number of system elements mapped for consumption by a system is the number of CIM elements implemented in the system, which transformations into their implementations in the system have been defined by the participant. This is designated by IRMC, followed by the designation of the system considered, as depicted in the following table. In the scenario, for example, system S1.2 implements the CIM elements I3 and I4, through its system elements S1.2<sub>I3</sub> and S1.2<sub>I4</sub>, respectively, which corresponding transformation functions  $g_{S1.2}(I3)$  and  $g_{S1.2}(I4)$  are already defined by participant P1.

**Table 70:** System elements mapped for consumption by a system

<b>Indicator name</b>	<b>Number of system elements mapped for consumption by a system (<math>IRMC_s</math>)</b>
<i>Informal definition</i>	Number of system elements which mappings to consume the corresponding CIM elements have been defined
<i>Formal definition</i>	$\forall s \in S,$ $IRMC_s =   RMC_s  $
<i>Range</i>	$\mathbb{N}_0$
<i>Scale</i>	Ratio
<i>Example</i>	$IRMC_{S1.1} = 0; IRMC_{S1.2} = 2;$ $IRMC_{S2.1} = 0, IRMC_{S2.2} = 0, IRMC_{S2.3} = 0,$ $IRMC_{S3.1} = 1, IRMC_{S3.2} = 1$

**Source:** Author

## 6.1.4 Information to be provided

### 6.1.4.1 Information that could be provided (baseline)

The number of system elements that could be provided by a system is the number of CIM elements implemented in the system that are also available in at least a system of another participant. This is designated by IRCP, followed by the designation of the system considered, as depicted in the following table. In the scenario, for example, system S1.1 could provide two system elements. These are the implementations of I1 and I2, which are also implemented in system S2.2 of participant P2.

**Table 71:** System elements that could be provided by a system

<i>Indicator name</i>	<i>Number of system elements that could be provided by a system (<math>IRCP_s</math>)</i>
<i>Informal definition</i>	Number of system elements that implement CIM elements: - available (implemented) in the system; - available (implemented) in at least a system of another participant
<i>Formal definition</i>	$\forall s \in S,$ $IRCP_s =  RCP_s $
<i>Range</i>	$\mathbb{N}_0$
<i>Scale</i>	Ratio
<i>Example</i>	$IRCP_{S1.1} = 2; IRCP_{S1.2} = 3;$ $IRCP_{S2.1} = 3, IRCP_{S2.2} = 2, IRCP_{S2.3} = 1,$ $IRCP_{S3.1} = 2, IRCP_{S3.2} = 1$

**Source:** Author

## 6.1.4.2 Information that should be provided (potential performance)

The number of system elements that should be provided by a system is the number of CIM elements implemented in the system that are also available in at least a system of another participant and that are required by the other participants that also implement them. This is designated by IRSP, followed by the designation of the system considered, as depicted in the following table. In the scenario, for example, S1.1 should provide one system element. This is the implementation of I1 that is available in the system S3.2 of participants P3 and is required by this participant.

**Table 72:** System elements that should be provided by a system

<b>Indicator name</b>	<b>Number of system elements that should be provided by a system (<math>IRSP_s</math>)</b>
<i>Informal definition</i>	Number of system elements that implement CIM elements: <ul style="list-style-type: none"> <li>- available (implemented) in the system;</li> <li>- available (implemented) in at least one system of another participant</li> <li>- required by the participants that already implement it in their systems</li> </ul>
<i>Formal definition</i>	$\forall s \in S,$ $IRSP_s =  RSP_s $
<i>Range</i>	$\mathbb{N}_0$
<i>Scale</i>	Ratio
<i>Example</i>	$IRSP_{S1.1} = 1; IRSP_{S1.2} = 1;$ $IRSP_{S2.1} = 3, IRSP_{S2.2} = 1, IRSP_{S2.3} = 1,$ $IRSP_{S3.1} = 0, IRSP_{S3.2} = 0$

**Source:** Author

6.1.4.3 Information that must be provided (actual performance)

The number of system elements that must be provided by a system is the number of CIM elements implemented in the system that are also available in at least a system of another participant, that are required by the other participants that also implement them, and which transformations to be provided from this system have been defined. This is designated by IRHP, followed by the designation of the system considered, as depicted in the following table. In the scenario, for example, S1.2 must provide one system element. This is the implementation of I1, that is available in the system S3.2 of participants P3, is required by this participant and the transformation function to provide it is defined as  $f_{I1}(S1.2_{I1})$ .

**Table 73:** System elements that must be provided by a system

<i>Indicator name</i>	<i>Number of system elements that must be provided by a system (IRHP<sub>s</sub>)</i>
<i>Informal definition</i>	Number of system elements implementing CIM elements: <ul style="list-style-type: none"> <li>- available (implemented) in the system;</li> <li>- available (implemented) in at least one system of another participant</li> <li>- required by the participants that already implement it in their systems</li> <li>- which transformations to provide them have been defined</li> </ul>
<i>Formal definition</i>	$\forall s \in S,$ $IRHP_s =   RHP_s  $
<i>Range</i>	$\mathbb{N}_0$
<i>Scale</i>	Ratio
<i>Example</i>	$IRHP_{S1.1} = 0; IRHP_{S1.2} = 1;$ $IRHP_{S2.1} = 0, IRHP_{S2.2} = 0, IRHP_{S2.3} = 0,$ $IRHP_{S3.1} = 0, IRHP_{S3.2} = 0$

**Source:** Author



## 6.1.5 Information to be consumed

### 6.1.5.1 Information that could be consumed (baseline)

The number of system elements that could be consumed by a system is the number of CIM elements implemented in the system that are also available in at least a system of another participant. This is designated by IRCC, followed by the designation of the system considered, as depicted in the following table. In the scenario, for example, system S1.1 could consume two system elements. These are the implementations of I1 and I2. These CIM elements are implemented by the system elements S1.1<sub>I1</sub> and S1.1<sub>I2</sub> and also in systems S2.2 and S3.2 from participants P2 and P3, respectively.

**Table 74:** System elements that could consume from other systems

<i>Indicator name</i>	<i>Number of systems elements that could consume from other systems (IRCC<sub>s</sub>)</i>
<i>Informal definition</i>	Number of system elements implementing CIM elements: - available in the system  - available in at least a system of another participant
<i>Formal definition</i>	$\forall s \in S,$ $IRCC_s =  RCC_s $
<i>Range</i>	$\mathbb{N}_0$
<i>Scale</i>	Ratio
<i>Example</i>	$IRCC_{S1.1} = 2, IRCC_{S1.2} = 3;$  $IRCC_{S2.1} = 3, IRCC_{S2.2} = 2, IRCC_{S2.3} = 1,$  $IRCC_{S3.1} = 2, IRCC_{S3.2} = 1$

**Source:** Author

### 6.1.5.2 Information that should be consumed (potential performance)

The number of system elements that should be consumed by a system is the number of CIM elements implemented in the system, required by the participant and available in at least a system of another participant. This is designated by IRSC, followed by the designation of the system considered, as depicted

in the following table. In the scenario, for example, system S1.2 should consume two system elements. These are the implementations of I3 and I4, which are required by participant P1, implemented by the system elements S1.2<sub>I3</sub> and S1.2<sub>I4</sub> and also in systems S2.1 and S2.3 from participant P2.

**Table 75:** System elements that should consume from other systems

<i>Indicator name</i>	<i>Number of system elements that should consume from other systems (IRSC<sub>s</sub>)</i>
<i>Informal definition</i>	Number of system elements implementing CIM elements: <ul style="list-style-type: none"> <li>- available in the system</li> <li>- available in at least a system of another participant</li> <li>- required by the participant</li> </ul>
<i>Formal definition</i>	$\forall s \in S$ $IRSC_s =  RSC_s $
<i>Range</i>	$\mathbb{N}_0$
<i>Scale</i>	Ratio
<i>Example</i>	$IRSC_{S1.1} = 0; IRSC_{S1.2} = 2;$ $IRSC_{S2.1} = 0, IRSC_{S2.2} = 0, IRSC_{S2.3} = 0,$ $IRSC_{S3.1} = 2, IRSC_{S3.2} = 1$

**Source:** Author

### 6.1.5.3 Information that must be consumed (actual performance)

The number of system elements that must be consumed by a system is the number of CIM elements implemented in the system, required by the participant, available in at least a system of another participant, and which transformations to consume them from the CIM have been defined by the participant. This is designated by IRHC, followed by the designation of the system considered, as depicted in the following table. In the scenario, for example, system S1.2 must consume two system elements. These are the implementations of I3 and I4, which are required by participant P1, implemented

by the system elements S1.2<sub>I3</sub> and S1.2<sub>I4</sub> and also in systems S2.1 and S2.3 from participant P2. Moreover, the transformations necessary to consume them,  $g_{S1.2}(I3)$  and  $g_{S1.2}(I4)$ , have already been defined by P1.

**Table 76:** System elements that must consume from other systems

<i>Indicator name</i>	<i>Number of systems elements that must consume from other systems (IRHC<sub>s</sub>)</i>
<i>Informal definition</i>	Number of system elements implementing CIM elements: <ul style="list-style-type: none"> <li>- available in the system</li> <li>- available in at least a system of another participant</li> <li>- required by the participant</li> <li>- which transformations to be consumed from the CIM have been defined</li> </ul>
<i>Formal definition</i>	$\forall s \in S$ $IRHC_s =  RHC_s $
<i>Range</i>	$\mathbb{N}_0$
<i>Scale</i>	Ratio
<i>Example</i>	$IRHC_{S1.1} = 0; IRHC_{S1.2} = 2;$ $IRHC_{S2.1} = 0, IRHC_{S2.2} = 0, IRHC_{S2.3} = 0,$ $IRHC_{S3.1} = 1, IRHC_{S3.2} = 1$

**Source:** Author

## 6.2 Relevance indicators

To assess the relevance of an information exchange initiative we defined eight derived indicators (Franceschini et al., 2007). These indicators measure the relevance of a system as a provider and as a consumer of information. In addition, they distinguish the potential relevance from the actual relevance. While the potential relevance is based on the information that should be provided and consumed by the system (the information is required and available but there is no semantic interoperability), the actual relevance is based on the information that must be provided and consumed by the system (semantic interoperability established). In other words, a system is considered potentially relevant, for the information exchange process, before the semantic interoperability is established, and actually relevant

after establishing it.

These indicators can also be used to reason at higher levels of abstraction. Presently, these indicators are defined at the system level, but, like the performance indicators, we can aggregate them to make decisions at the participant, project or even at the program level, if necessary. We did not to define these higher order indicators, because they are a sum of the results of the lower levels. However, this might be necessary in assessing a real situation.

To define and demonstrate these indicators we followed the same strategy used before with the performance indicators. The relevance indicators are distributed across the same representation-targets used for defining the performance indicators in the previous section. As before, we provide a brief explanation of the indicator, followed by a table where it is defined formally and informally, accompanied by several examples based on the information exchange scenario presented earlier.

### 6.2.1 Information available

The relevance of a system based on the information available depends of the relevance on the information it has implemented. This is designated by ‘IPRP’, followed by the designation of the system considered, as depicted in the following table. In the scenario, for example, system S1.1 implements I1 and I2, hence its relevance is the sum of the relevance of these two system elements, which is 5.60.

**Table 77:** Relevance of a system based on the information available

<i>Indicator name</i>	<i>Relevance of a system based on the information available (IRIA<sub>s</sub>)</i>
<i>Informal definition</i>	Sum of the weighted relevance of each of the system elements that are available in the system
<i>Formal definition</i>	$\forall s \in S, \forall a \in RAS, \forall i \in \mathbb{N}$ $IRIA_s = \sum_{i=1}^{ RAS } WR_{ai}$
<i>Range</i>	$\mathbb{R}$
<i>Scale</i>	Ratio
<i>Example</i>	$IRIA_{S1.1} = 5.60; IRIA_{S1.2} = 5.90$ $IRIA_{S2.1} = 6.40; IRIA_{S2.2} = 5.60; IRIA_{S2.3} = 1.30$ $IRIA_{S3.1} = 5.10; IRIA_{S3.2} = 5.60$

**Source:** Author

## 6.2.2 Information required

The relevance of a system based on the information required depends of the relevance of the information implemented in the system which corresponding CIM elements are required by the participant. This is designated by 'IRIR', followed by the designation of the system considered, as depicted in the following table. In the scenario, for example, system S1.2 implements I3 and I4 that are also required by the participant, hence its relevance is the sum of the relevance of these two system elements, which is 2.60.

**Table 78:** Relevance of a system based on the information required

<i>Indicator name</i>	<i>Relevance of a system based on the information required (IRIR<sub>s</sub>)</i>
<i>Informal definition</i>	Sum of the weighted relevance of each of the system elements which corresponding CIM elements are required by the participant
<i>Formal definition</i>	$\forall s \in S, \forall a \in RR_s, \forall i \in \mathbb{N}$ $IRIR_s = \sum_{i=1}^{ RR_s } WR_{ai}$
<i>Range</i>	$\mathbb{R}$
<i>Scale</i>	Ratio
<i>Example</i>	$IRIR_{S1.1} = 0; IRIR_{S1.2} = 2.60$ $IRIR_{S2.1} = 0; IRIR_{S2.2} = 0; IRIR_{S2.3} = 0$ $IRIR_{S3.1} = 5.10; IRIR_{S3.2} = 5.60$

**Source:** Author

## 6.2.3 Information mapped

### 6.2.3.1 Information mapped for provisioning

The relevance of a system based on the information mapped for provisioning depends of the relevance of the information implemented in the system which transformations to provide it through the CIM are implemented. This is designated by 'IRFP', followed by the designation of the system considered, as depicted in the following table. In the scenario, for example, system S1.2 implements I1 that is also mapped for provisioning through the CIM, hence its relevance is 3.30.

**Table 79:** Relevance of a system based on the information mapped for provisioning

<b>Indicator name</b>	<b>Relevance of a system based on the information mapped for provisioning (IRFP<sub>s</sub>)</b>
<b>Informal definition</b>	Sum of the weighted relevance of each of the system elements that are mapped for provisioning
<b>Formal definition</b>	$\forall s \in S, \forall a \in RMP_s, \forall i \in \mathbb{N}$ $IRFP_s = \sum_{i=1}^{ RMP_s } WR_{ai}$
<b>Range</b>	$\mathbb{R}$
<b>Scale</b>	Ratio
<b>Example</b>	$IRFP_{S1.1} = 0; IRFP_{S1.2} = 3.30$ $IRFP_{S2.1} = 0; IRFP_{S2.2} = 0; IRFP_{S2.3} = 0$ $IRFP_{S3.1} = 0; IRFP_{S3.2} = 0$

**Source:** Author

### 6.2.3.2 Information mapped for consumption

The relevance of a system based on the information mapped for consumption depends of the relevance of the information implemented in the system which transformations to consume it through the CIM are implemented. This is designated by ‘IRFC’, followed by the designation of the system considered, as depicted in the following table. In the scenario, for example, system S1.2 implements I3 and I4 that are also mapped for consumption through the CIM, hence its relevance is 2.60.

**Table 80:** Relevance of a system based on the information mapped for consumption

<i>Indicator name</i>	<i>Relevance of a system based on the information mapped for consumption (IRFC<sub>s</sub>)</i>
<i>Informal definition</i>	Sum of the weighted relevance of each of the system elements that are mapped for consumption
<i>Formal definition</i>	$\forall s \in S, \forall a \in RMCs, \forall i \in \mathbb{N}$ $IRFC_s = \sum_{i=1}^{ RMC_s } WR_{ai}$
<i>Range</i>	$\mathbb{R}$
<i>Scale</i>	Ratio
<i>Example</i>	$IRFC_{S1.1} = 0; IRFC_{S1.2} = 2.60$ $IRFC_{S2.1} = 0; IRFC_{S2.2} = 0; IRFC_{S2.3} = 0$ $IRFC_{S3.1} = 3.30; IRFC_{S3.2} = 3.30$

**Source:** Author

## 6.2.4 Information to be provided

### 6.2.4.1 Information that should be provided

The potential relevance of a system as a provider of information depends on the relevance of the information it should provide to the systems of other participants. This is designated by 'IPRP', followed by the designation of the system considered, as depicted in the following table. In the scenario, for example, system S1.1 should provide only one CIM element (I1) to other systems. Since the relevance of this element was scored 3.30 by the experts, the relevance of this system to the information exchange process, as a provider of information, is 3.30. However, this relevance is potential, because we are not considering if the semantic interoperability to provide the implementation of I1 has been developed.

**Table 81:** Potential relevance of a system as a provider of information

<b>Indicator name</b>	<b>Potential relevance of a system as a provider of information (IPRP<sub>s</sub>)</b>
<i>Informal definition</i>	Sum of the weighted relevance of each of the system elements that should be provided by the system
<i>Formal definition</i>	$\forall s \in S, \forall a \in RSP_s, \forall i \in \mathbb{N}$ $IPRP_s = \sum_{i=1}^{ RSP_s } WR_{ai}$
<i>Range</i>	$\mathbb{R}$
<i>Scale</i>	Ratio
<i>Example</i>	$IPRP_{S1.1} = 3.30; IPRP_{S1.2} = 3.30$ $IPRP_{S2.1} = 6.40; IPRP_{S2.2} = 3.30; IPRP_{S2.3} = 1.30$ $IPRP_{S3.1} = 0; IPRP_{S3.2} = 0$

**Source:** Author

#### 6.2.4.2 Information that must be provided

The actual relevance of a system as a provider of information depends on the relevance of the information it must provide to the systems of other participants. This is designated by ‘IARP’, followed by the designation of the system considered, as depicted in the following table. In the scenario, for example, system S1.2 should provide only one CIM element (I1) to other systems. Since the relevance of this element was scored 3.30 by the experts, the relevance of this system to the information exchange process, as a provider of information, is 3.30. In this case, the relevance is actual, because we are considering that the semantic interoperability to provide the implementation of I1 has been developed.



**Table 82:** Actual relevance of a system as a provider of information

<i>Indicator name</i>	<i>Actual relevance of a system as a provider of information (IARP<sub>s</sub>)</i>
<i>Informal definition</i>	Sum of the weighted relevance of each of the system elements that must be provided by the system
<i>Formal definition</i>	$\forall s \in S, \forall a \in RHP_s, \forall i \in \mathbb{N}$ $IARP_s = \sum_{i=1}^{ RHP_s } WR_{ai}$
<i>Range</i>	$\mathbb{N}_0$
<i>Scale</i>	Ratio
<i>Example</i>	$IARP_{S1.1} = 0; IARP_{S1.2} = 3.30$ $IARP_{S2.1} = 0; IARP_{S2.2} = 0; IARP_{S2.3} = 0$ $IARP_{S3.1} = 0; IARP_{S3.2} = 0$

**Source:** Author

## 6.2.5 Information to be consumed

### 6.2.5.1 Information that should be consumed

The potential relevance of a system as a consumer of information depends on the relevance of the information it should consume from the systems of other participants. This is designated by ‘IPRC’, followed by the designation of the system considered, as depicted in the following table. In the scenario, for example, system S3.2 should consume only one CIM element (I1) from other systems. Since the relevance of this element was scored 3.30 by the experts, the relevance of this system to the information exchange process, as a consumer of information, is 3.30. However, this relevance is potential, because we are not considering if the semantic interoperability to consume I1 has been developed.

**Table 83:** Potential relevance of a system as a consumer of information

<i>Indicator name</i>	<i>Potential relevance of a system as a consumer of information (IPRC<sub>s</sub>)</i>
<i>Informal</i>	Sum of the weighted relevance of each of the system elements that should consume

<i>definition</i>	from the CIM
<i>Formal definition</i>	$\forall s \in S, \forall a \in RSCs, \forall i \in \mathbb{N}$ $IPRC_s = \sum_{i=1}^{ RSC_s } WR_{ai}$
<i>Range</i>	$\mathbb{N}_0$
<i>Scale</i>	Ratio
<i>Example</i>	$IPRC_{S1.1} = 0; IPRC_{S1.2} = 2.60$ $IPRC_{S2.1} = 0; IPRC_{S2.2} = 0; IPRC_{S2.3} = 0$ $IPRC_{S3.1} = 5.10; IPRC_{S3.2} = 3.30$

#### 6.2.5.2 Information that must be consumed

The actual relevance of a system as a consumer of information depends on the relevance of the information it must consume from the systems of other participants. This is designated by ‘IARC’, followed by the designation of the system considered, as depicted in the following table. In the scenario, for example, system S3.2 should consume only one CIM element (I1) from other systems. Since the relevance of this element was scored 3.30 by the experts, the relevance of this system to the information exchange process, as a consumer of information, is 3.30. In this case, the relevance is actual, because we are considering that the semantic interoperability to consume I1 has been developed.

**Table 84:** Actual relevance of a system as a consumer of information

<i>Indicator name</i>	<b>Actual relevance of a system as a consumer of information (IARC<sub>s</sub>)</b>
<i>Informal definition</i>	Sum of the weighted relevance of each of the system elements that must consume from the CIM

---

*Formal definition*  $\forall s \in S, \forall a \in RHCs, \forall i \in \mathbb{N}$

$$IARC_s = \sum_{i=1}^{|RHC_s|} WR_{ai}$$

---

*Range*  $\mathbb{N}_0$

---

*Scale* Ratio

---

*Example*  $IARC_{S1.1} = 0; IARC_{S1.2} = 2.60$

$IARC_{S2.1} = 0; IARC_{S2.2} = 0; IARC_{S2.3} = 0$

$IARC_{S3.1} = 3.30; IARC_{S3.2} = 3.30$

---

**Source:** Author

(page intentionally left in blank)

## 7 Demonstration

In this chapter we will describe how we have used the iShare framework in a real situation. This is essential to demonstrate that the artefact developed is useful and that it meets the objectives defined. Particularly, we will demonstrate how the iShare framework allowed us to determine the performance and relevance of the semantic interoperability (present, desired and possible) in an information exchange initiative. We will also demonstrate how it is feasible to use it in a large-scale situation in a cost-effective way, and how it can be used to generate consensus among stakeholders, regarding the relevance of the information, which will determine the priorities of the interoperability developments and, consequently, of achieving the benefits expected from it. Finally, we will demonstrate that the iShare framework is easy to use, that it is independent from the domain where it is being used and that it can adapt to organizational and context changes.

To this aim, our demonstration is organized in three phases. The first is the preparation phase, where we designed the questionnaire and developed a software application to perform some of the calculations. The second is the execution phase, where we submitted the questionnaire, collected the data and ensured its quality, calculated the framework components and obtained the consensus of the organizations involved regarding the results achieved. Finally, the third phase is the results presentation and evaluation phase. In this phase we describe the organizations' answers to the questionnaire, we demonstrate how the iShare framework can be used to improve the semantic interoperability of those organizations and we evaluate the framework according to the objectives defined in chapter 4.

### 7.1 Preparation

#### 7.1.1 Questionnaire design

The questionnaire submitted to the participants of the NIPIMAR project was an excel file, divided into three parts, which are depicted below and in appendix 6 as well, for better visualization. The first part, depicted in the following figure, was an excel sheet, containing an introduction to the questionnaire that established its scope, purpose, objectives and the methodology to be followed. After filling in the questionnaire, the organizations were invited to submit it to a specified email.

The objectives of the questionnaire were three. First, to capture the organizations' information requirements. Second, to capture the availability of the information in the organizations' computer systems and third, to capture the organizations' perspective on the relevance of the information included in the questionnaire<sup>4</sup> to the maritime risks<sup>5</sup> provided. To this end, while answering the questionnaire, the NIPIMAR project participants were asked to take into consideration all their systems that contained information related or relevant for maritime surveillance.

---

<sup>4</sup> All information elements were extracted from the CoopP project version of the CISE information model

<sup>5</sup> All risks were extracted from the CISE cost-benefit analysis performed during the CoopP project

Before filling in the questionnaire, the organizations were informed that their answers and the resulting analysis would be used according to the project terms of reference and could be used in other initiatives as well, provided that either their explicit permission was granted or their anonymity was ensured. The permission to use the results of this questionnaire in this research is presented in annex A. We decided to omit, in this report and in related publications, the identity of the organizations involved, since the disclosure of which information is required and available to conduct maritime surveillance by a specific authority is considered sensitive and could entail security risks.

**Figure 28:** Questionnaire part I - Introduction

Source: Author

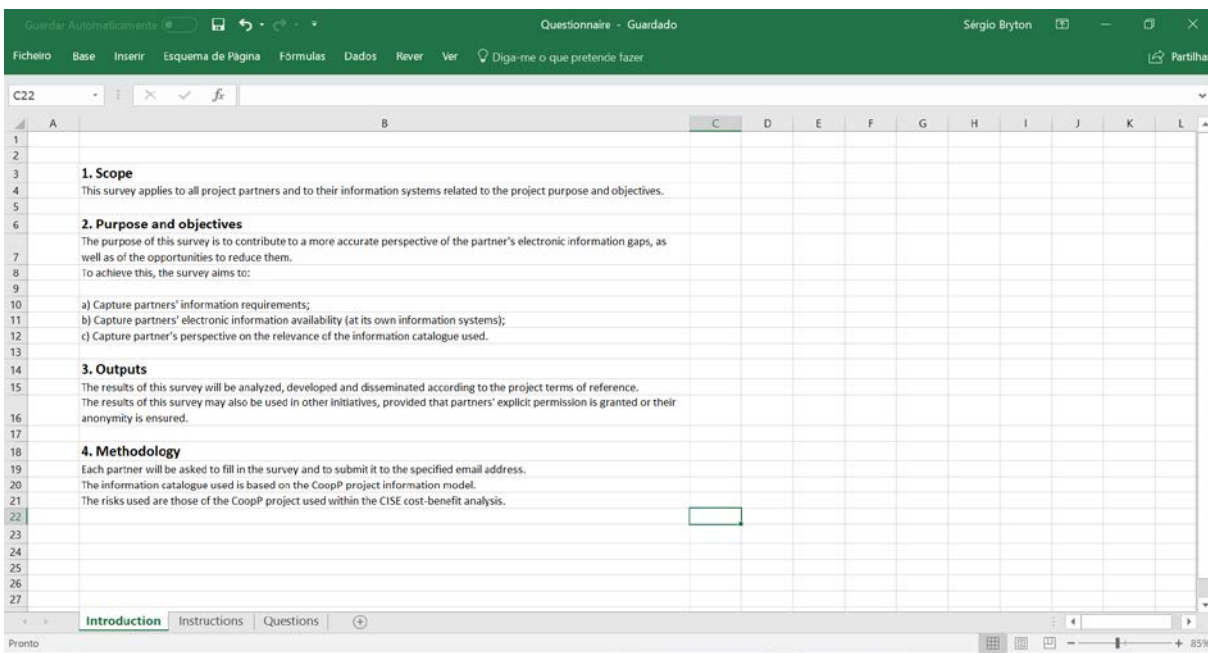

The second part, depicted in the following figure, was another excel sheet, containing a set of instructions regarding how to fill in the questionnaire and how to obtain technical support. The detailed specification of the CISE information model was attached to the questionnaire to support in clarifying the meaning of each of the information elements (699) contained in the questionnaire.

Figure 29: Questionnaire part II - Instructions

Source: Author

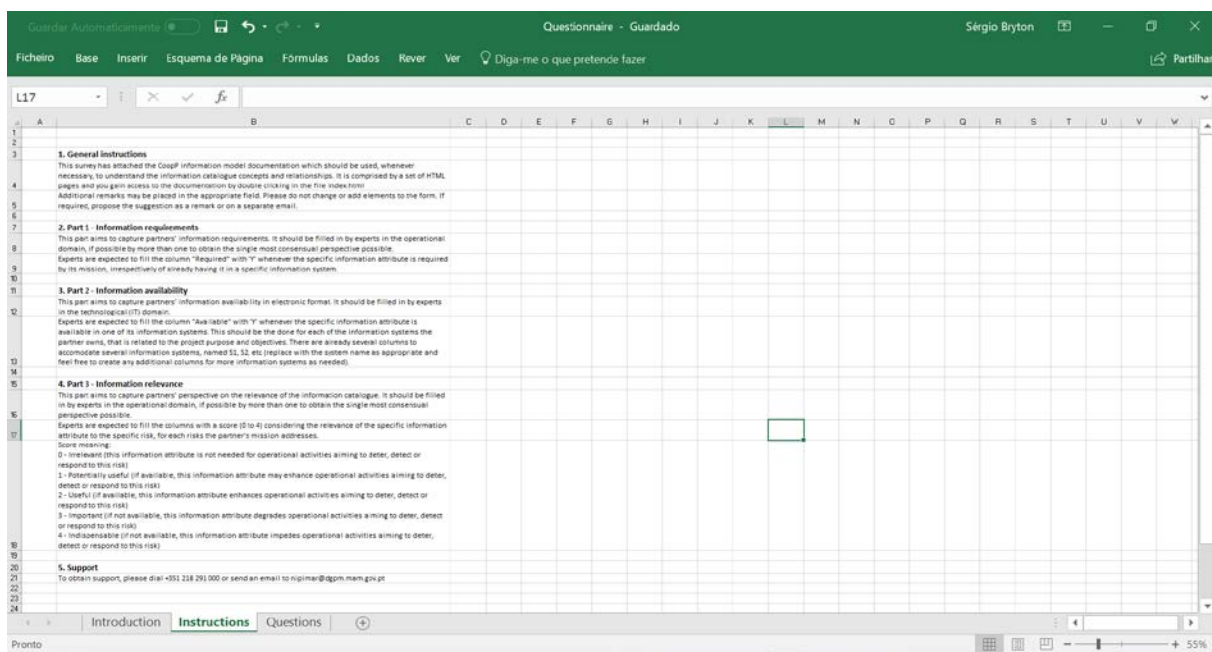

Regarding the first part of the questions – information requirements – the organizations were told that it should be filled in by experts in the operational domain, and if possible by more than one to obtain the single most consensual perspective possible. It was expected that experts would fill in the column

“Required” with the letter ‘Y’ whenever the specific information attribute was required by the organization’s mission, irrespectively of already having it in a specific information system. While developing the questionnaire, special attention should also be paid to the fact that experts’ availability is often scarce, which could hamper in filling in very long surveys.

Regarding the second part of the questions – information availability – it should be filled in by experts in the IT domain. These experts were expected to fill in the column “Available” with “Y” whenever the specific information attribute was available in one of its information systems. This should be done for each of the information systems the organizations owns that is related to the purpose and objectives of the NIPIMAR project. Several columns named S1 through S6 were provided in the questionnaire, each of which representing a specific system, and the organizations were also given the possibility to add more columns if they had more than 6 related systems.

Regarding the third part of the questions – information relevance – it should be filled in by experts in the operational domain, again if possible by more than one to obtain the single most consensual perspective possible. Experts were asked to fill the corresponding columns with a score (0 to 4 as per the table below) considering the relevance of the each information element to each of the risks presented that the organization addresses in its mission.

**Table 85:** Value and meaning of the information relevance scores

Score	Designation	Description
0	Irrelevant.	This information element is <b>not needed</b> for operational activities aiming to deter, detect or respond to this risk
1	Potentially useful	<b>If available</b> , this information element <b>may enhance</b> operational activities aiming to deter, detect or respond to this risk
2	Useful	<b>If available</b> , this information element <b>enhances</b> operational activities aiming to deter, detect or respond to this risk
3	Important	<b>If not available</b> , this information element <b>degrades</b> operational activities aiming to deter, detect or respond to this risk
4	Indispensable	<b>If not available</b> , this information element <b>impedes</b> operational activities aiming to deter, detect or respond to this risk

**Source:** Author

Finally, the third part of the questionnaire, depicted in the following figure, was the last excel sheet in the file, containing a matrix for the experts to fill in (questions) according to the instructions given. As we can see, all (699) the information elements of the CISE model were introduced in the questionnaire, divided into entities (or classes) and attributes. Then these were followed by the “Required” column (first part of the questions), by the systems columns “S1” through “S6” (second part of the questions) and finally by the risks columns “R1” through “R7” (third part of the questions).



Figure 30: Questionnaire part III - Questions

Source: Author

	A	B	C	D	E	F	G	H	I	J	K	L	M	N	O	P
1	ENTITY_NAME	ATTRIBUTE_NAME	REQUIRED	S1	S2	S3	S4	S5	S6	R1	R2	R3	R4	R5	R6	R7
2	Aircraft	Color														
3	Aircraft	ExternalMarkings														
4	Aircraft	MaximumSpeed														
5	Aircraft	Metadata														
6	Aircraft	Name														
7	Aircraft	Nationality														
8	Aircraft	TotalPersonsOnBoard														
9	LandVehicle	Color														
10	LandVehicle	ExternalMarkings														
11	LandVehicle	MaximumSpeed														
12	LandVehicle	Metadata														
13	LandVehicle	Name														
14	LandVehicle	Nationality														
15	LandVehicle	TotalPersonsOnBoard														
16	Vessel	IMONumber														
17	Vessel	MMSI														
18	Vessel	Callsign														
19	Vessel	NavigationalStatus														
20	Vessel	RegistryDate														
21	Vessel	RegistryNumber														
22	Vessel	INMARSATNumber														
23	Vessel	GrossTonnage														

Since the NIPIMAR project is in its early stages, there is no semantic interoperability implemented among the organizations involved. Otherwise, we would have to include specific questions to assess this as well. The way to do this would be very similar to the part where the availability of the information is declared, and an example of how this should be done, based on the information sharing scenario, can be seen in appendix 8.

The risks selected for the third part of the questions were the maritime risks that the organizations involved in the NIPIMAR project usually tackle within their missions and which were used to develop a

cost-benefit analysis of the CISE during the Coop project (Finnish Border Guard, 2014). Namely, these were Illegal, unreported and unregulated fishing (R1); Illegal oil spills and discharges (R2); Counterfeit goods (R3); Maritime accidents (R4); Drug trafficking (R5); Irregular migration (R6) and Piracy (R7).

**Figure 31:** Information sharing in maritime surveillance

Source: Author

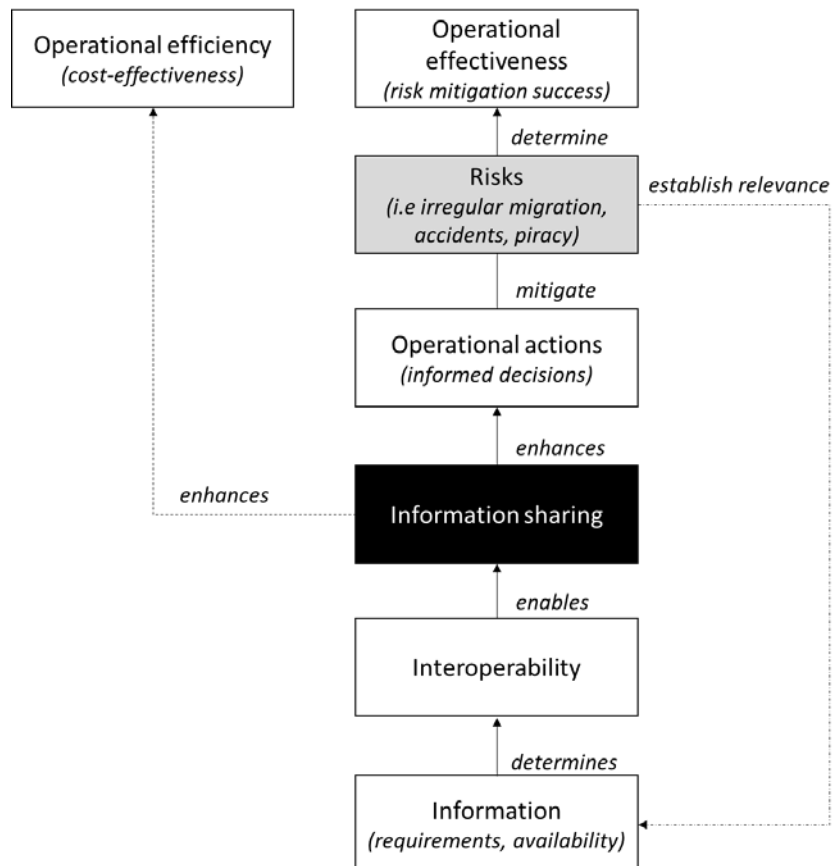

We can observe, in the figure above, the rationale between information requirements, information sharing, risks, and operational efficiency and effectiveness in maritime surveillance. The purpose of enhancing maritime surveillance information sharing is twofold. Firstly, efficiency; if organizations can access information already existing in other organizations, they do not have to incur into duplicate expenditures to collect, store and process that information again. Secondly, effectiveness; if organizations have more relevant information then they may take more informed decisions which, ultimately, can lead to more effective operational actions aiming the deterrence, detection and response to specific risks.

### 7.1.2 Software application

Once the questionnaires were received, it became necessary to consolidate all the answers and to calculate the performance and relevance indicators. Initially, we did it by hand, for the information sharing scenario, which results are presented in appendix 5. However, it soon became clear that, even for such a simple situation, a manual process would be very time consuming and error prone. Therefore, we developed a software application, using the Python programming language (Python Software Foundation, 2018), to facilitate this task. The main objective of the software application is, therefore, to take as input a .csv file, containing all the answers to the questionnaire consolidated, and to deliver as output another .csv file, containing the information necessary for calculating the performance and relevance indicators.

The consolidation of the answers to the questionnaires was done manually, because it is a simple and quick process, and therefore does not make the case for automation. In addition, we also decided that our software application should not do the final calculations of the indicators, since we can use the features already available in common spreadsheets, such as dynamic tables and graphs, to calculate the indicators and to depict them in charts for further analysis. Therefore, to do this, we used Microsoft Excel and the .csv file returned by the software application. In the following figure we depict the tools and activities used for processing the data, since the questionnaires were received until the indicators of performance and relevance became available.

**Figure 32:** Data processing tools and activities

Source: Author

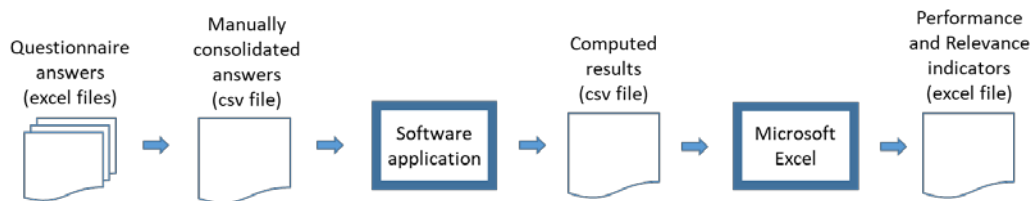

To test the software application, we developed the .csv file presented in appendix 8, which is based on the information sharing scenario presented in appendix 1, and processed it. The result was the .csv file presented in appendix 9, which results we compared with the calculations previously performed manually and presented in appendix 5. This was a successful approach, since we found some errors in the initial versions of the software and, by comparing it with results which we knew beforehand, we were able to detect and correct them. Presently there are no errors known in the software application.

The software developed, which listing is presented in appendix 7, is bound to the type and order of the columns used, but not to the number of systems or business factors (risks), meaning that if the methodology and base architecture of the questionnaire is followed, the software can be reused in other situations, without any changes. The software is also independent from the number of information elements used. In addition, it is worth mentioning that the software developed was not optimized. However, the time to execute the software, in an ordinary computer, is presently in the order of seconds, which is adequate for the NIPIMAR case.

### 7.1.3 Preparation of the experts

A support team was set up and available during the preparation and execution phases. This team prepared the experts in advance, regarding the questionnaire and what was expected from them.

## 7.2 Execution

### 7.2.1 Data collection

The questionnaires were submitted by email to the points of contact of each of the organizations participating in the project. The experts answered the questionnaire individually, collecting and harmonizing additional opinions from other colleagues in their agencies, whenever possible. Moreover, they have only expressed their opinion regarding the risks addressed by their agencies' missions, as per the instructions provided.

Afterwards, the answers were returned to us by email. The average time for each expert to answer the questionnaire was between 40 and 120 person hours (1 to 3 weeks). Filling in the requirements generated some questions, which were promptly answered by the support team and, whenever necessary, dedicated on-site support actions were also conducted. Upon receiving the answers from all organizations these were merged into the .csv file that is presented in appendix 10, as earlier described.

### 7.2.2 Data quality

As soon as the replies were received, they were checked for completeness (e.g. all questions were answered) and coherence (e.g. consistency among the answers). These checks consisted mainly of manual inspections, often supported by auxiliary calculations made on the excel file received. Special attention was paid to missing values and in ensuring that the correct risks have been evaluated. Whenever necessary, experts were invited to revise their answers and were supported as required. In the future, the software application may be enhanced to check automatically most of the quality requirements.

### 7.2.3 Data calculations

As presented above, our questionnaire entails four main elements. These are a set of  $m$  information elements (E), a set of  $n$  risks (A) each of which with its specific weight (W) and the relevance scale. To establish the relative weights of the risks we used the estimated impacts of the CISE<sup>6</sup> (Finnish Border Guard, 2014) into each of them, and normalized the values to add up to one, as recommended in the WSM method (Triantaphyllou, 2000). The results are presented in the table below.

**Table 86:** Weights assigned to each risk

	$R_1$	$R_2$	$R_3$	$R_4$	$R_5$	$R_6$	$R_7$
<i>Benefit (M €/year)</i>	82	63	61	42	61	61	54
<i>Weight (W)</i>	0.19	0.15	0.14	0.10	0.14	0.14	0.13

**Source:** Author

Then, to calculate the relevance of each information element, we took a two-step approach. Firstly, we determined the mean relevance of each information element for each risk, considering the answers of the organizations that addressed each particular risk. Secondly, we calculated the relevance of each information element for all risks, based on the previously calculated relevance and on the relative weights of each risk.

$$S_i = \sum_{j=1}^n (V_{i,j} \times W_j), \text{ for } i = 1, 2, 3, \dots, m. \tag{1}$$

For the second step, we used the formula above based on the WSM, as follows.  $V$  is the relevance of each

<sup>6</sup> These impacts resulted from the cost-benefit analysis performed during the CoopP project

information element ( $i$ ) to each risk ( $j$ ) and  $W$  is the relative weight of each risk ( $j$ ). It follows that  $m$  is the number of information elements (699) and  $n$  the number of risks (7). The results are presented in appendix 11, and an excerpt of it is depicted in the following table, as an example.

**Table 87:** Example of the results of the calculations performed by the software application

CIM Element	System	Org.	Rep. Target	RF1	RF2	RF3	RF4	RF5	RF6	RF7	Rel.
Vessel::IMONumber	SA.1	PA	RA	3,33	3,00	2,67	3,33	3,00	3,00	3,25	0,76
Vessel::MMSI	SA.1	PA	RA	3,33	3,00	2,67	3,33	3,00	3,00	3,25	0,76
Vessel::Callsign	SA.1	PA	RA	3,67	3,25	3,00	3,67	3,00	3,00	3,25	0,81

**Source:** Author

## 7.2.4 Harmonization of the results

It must be considered that experts hardly have the same experience and knowledge, and hence perceive the benefits of the same information differently. Consequently, the relevance of an information element may vary among organizations, and even among experts of the same organization, which makes necessary to harmonize the answers received.

To perform this harmonization, first we calculated the mean relevance of each information element for each risk, based on the answers of all experts, and then circulated the results among the experts which answered the questionnaire and collected their feedback. While doing this process, we found that showing them the relevance that resulted from the answers of all experts helped them to understand better the relationship between their opinion and that of other experts, and also allowed them to perceive the implications of their answers. Overall, the questionnaire was circulated two times, until consensus was reached.

## 7.3 Results and evaluation

In this section we describe the results obtained with the iShare framework, after being applied to the NIPIMAR case, and evaluate it, according to the objectives established. We start by characterizing the present situation, based on the answers to the questionnaire and on the core concepts. Then, we assess the performance and relevance of the semantic interoperability and, finally, we demonstrate how the iShare framework can be used in three common scenarios: 1) the design of programs and projects, 2) funding projects and programs and 3) managing programs and projects.

### 7.3.1 Characterizing the situation

#### 7.3.1.1 Participants

The organizations that answered the questionnaire were 6. Each of which addressing different risks. In the questionnaire, when describing the relevance of each information element to each risk, the organizations had 7 different risk to assess the information with. However, if the organizations did not have any role

regarding a particular risk, they were asked not to assess the information regarding that specific risk. As such, the following table presents the risks addressed by each organization, and hence the risks each organization used to assess the relevance of each information element.

**Figure 33:** Risks addressed by each organization

**Source:** Author

Risk	PA	PB	PC	PD	PE	PF
RF1 (Illegal, unreported and unregulated fishing)	Y	Y				Y
RF2 (Illegal oil spills and discharges)	Y	Y	Y			Y
RF3 (Counterfeit goods)	Y	Y	Y			
RF4 (Maritime accidents)	Y	Y				Y
RF5 (Drug trafficking)	Y	Y	Y		Y	
RF6 (Irregular migration)	Y	Y		Y		
RF7 (Piracy)	Y	Y	Y			Y

From the organizations that answered the questionnaire, and as depicted in the following figure, two only address one risk, two other address four risks and the remainder two address all the risks considered. In addition, each risk is addressed by at least three of the organizations answering the questionnaire, which means that the relevance of each information element was assessed at least by 50% of the organizations that answered the questionnaire.



**Figure 34: Number of risks addressed by each organization**

Source: Author

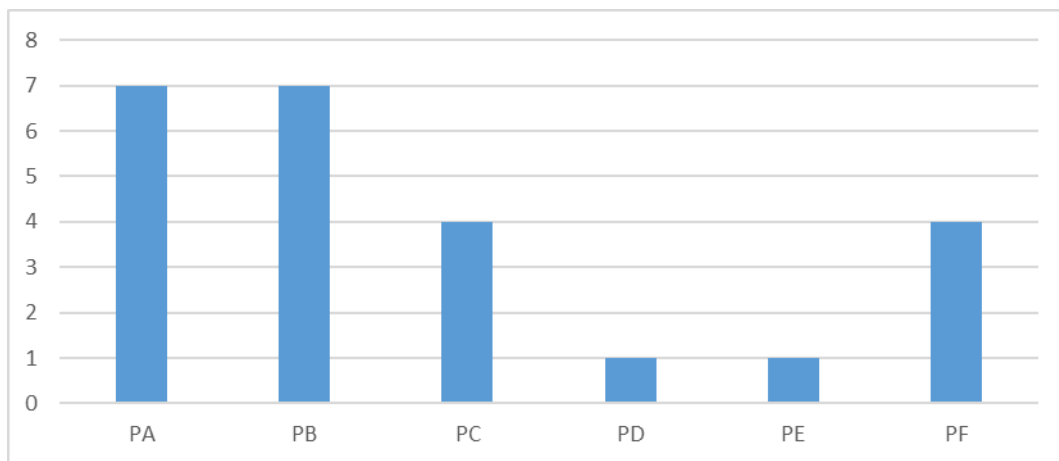

#### 7.3.1.2 Information systems

In the questionnaire, the various organizations were offered the possibility to identify which data was already available in up to 6 different systems which, from our experience, is a number large enough to match their reality. As a result, organizations mentioned to have relevant information available in between 1 and 5 systems, and most of them only have the information available in a single system. In addition, only one organization – E - mentioned not to have any information available in any system, and the organization with the largest number of systems was F, as per the following picture.

**Figure 35:** Number of systems available, with relevant information, per organization

**Source:** Author

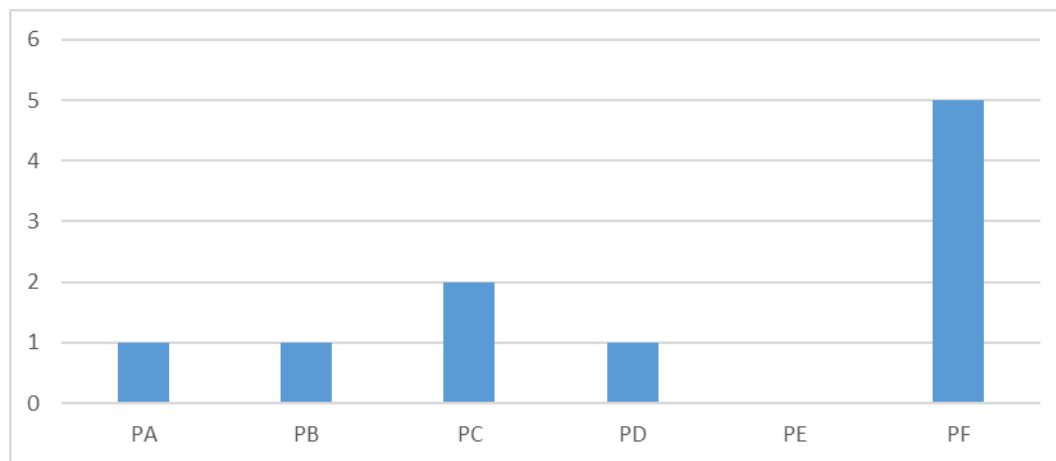

### 7.3.1.3 Information transformations and mappings

The NIPIMAR project is in its early stages. Therefore, and in spite the common information model being already defined, the process of defining information transformations between the CIM and the existing systems has not yet started. Consequently, the NIPIMAR does not entail any transformation functions or services implemented, hence no information mapped as well. For the time being, organizations are still in the process of identifying which information should be exchanged with which organization, why and under which priority, which is good for the validation of the iShare framework, since this is exactly the reason for which it was designed.

### 7.3.1.4 Information needs and availability

All organizations have identified the information they need (required for their missions) and the information they have available in their information systems. From the picture below, we can see that 100% (699) of the CIM information elements are needed by at least one of the organizations, and also that about 61% (428) of the CIM information elements is available in at least one organization. This means that 39% (271) of the information needed by the organizations is not available in any of them, which

implies that they will have to look for this information in some other organizations or to develop capabilities to collect it, such as new sensors and systems. Without this information, organizations cannot be at their peak of efficiency and effectiveness.

**Figure 36:** Overall information needs and availability

**Source:** Author

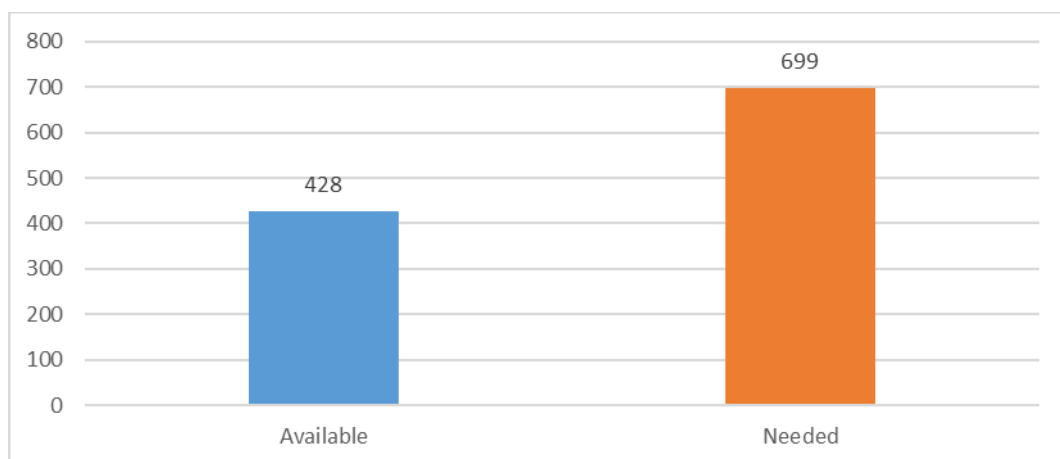

Specifically, we can see, in the picture below, how many of the CIM information elements are needed and available in each organization. As we have seen above, some of the information that is needed by an organization might not be available in any of the organizations considered, whereas some other information might be available in at least another organization, and this is where the information exchange among them becomes relevant. Instead of developing new capabilities to collect the information they miss, organizations may reuse the resources already in place to obtain it.

**Figure 37:** Information needs and availability per organization

**Source:** Author

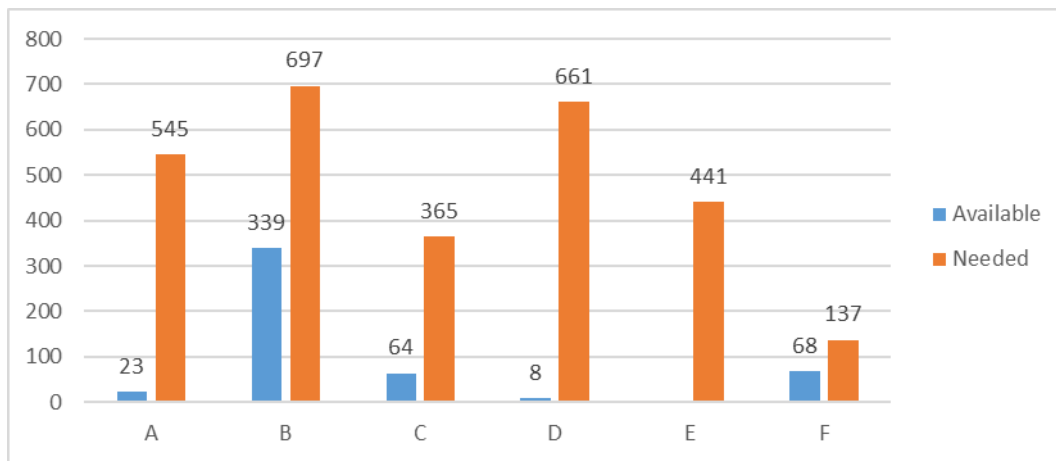

As we can see, there is a big gap between the information availabilities and needs of all the organizations considered. Organization A has only 4% (23) of the information needed (545). Organization B is the one needing more information - over 99% (697) - and has already roughly 49% (339) of the information needed. Organization C has only about 18% (64) of the information needed (365). Organization D is the one in the worst situation, having only about 1% (8) of the information needed (661). Organization E is also in a very poor situation, but we should recall that it has no information systems so, for the time being, information exchange is not feasible electronically and this organization should invest in developing its IT capabilities first. Finally, organization F has only 49% (68) of the information needed (137). Overall, the information gaps, in the organizations considered, vary between 51% and 99%, and if we think that 61% of the information needed is available in some organization, we conclude that an information exchange initiative among these organizations could be worthwhile.

### 7.3.2 Improving the semantic interoperability

The main objective of the iShare framework is to help decision makers and organizations involved in an information exchange initiative to improve the semantic interoperability of their systems. To do this, we

need to assess the existing situation and then choose the actions that must be executed to improve it. Herein we will demonstrate how this can be done, using the iShare indicators performance and relevance indicators.

However, any initiative to develop semantic interoperability is constrained to the ability of the systems to consume or provide that information. Particularly, the systems must have already available, in their information models, the implementations of the information elements needed. Despite the relevance of the information needed that is not available in any of the systems or that cannot be consumed by the systems needing, this is not (yet) a problem of lack of semantic interoperability but, instead, either a problem of lack of information (in the first case) or a problem of lack of features to enable the systems to consume the necessary information (in the second case). For this reason we have to focus our analysis in the systems implementations and not in the CIM.

#### 7.3.2.1 Assessment

The assessment of the existing situation is divided in two parts. First, we determine the semantic interoperability performance and then we determine its relevance. Therefore, we will follow this approach for each of the representation targets of the iShare framework indicators as applicable.

Since the NIPIMAR is still a project under development, presently there are no information mappings between the systems of the organizations and the CIM. Consequently, this limits this demonstration, in the sense that although we have computed the indicators specific to semantic interoperability (information mapped for the consumption and provisioning representation targets), the results were zero. Therefore, in this assessment, we do not have a specific section to present the results for the indicators of these specific representation targets.

##### a) Information available

Although having presented above the information available in the organizations participating in NIPIMAR, here we will use the iShare indicators to drill it down and to present the CIM information elements available in each system of each organization. This is depicted in the following figure, where we can see that the system with more CIM information elements is that of organization B with 79% of the information available in the initiative – 339 CIM elements out of the 428 different CIM elements that are available in all the systems. Likewise, we can see that system 5 from organization F is the system with less information, less than 1% of all the different CIM elements availability in all the systems. Regarding the rest of the systems, the information available varies between 8% and 15% of the all the different CIM elements available in all systems.

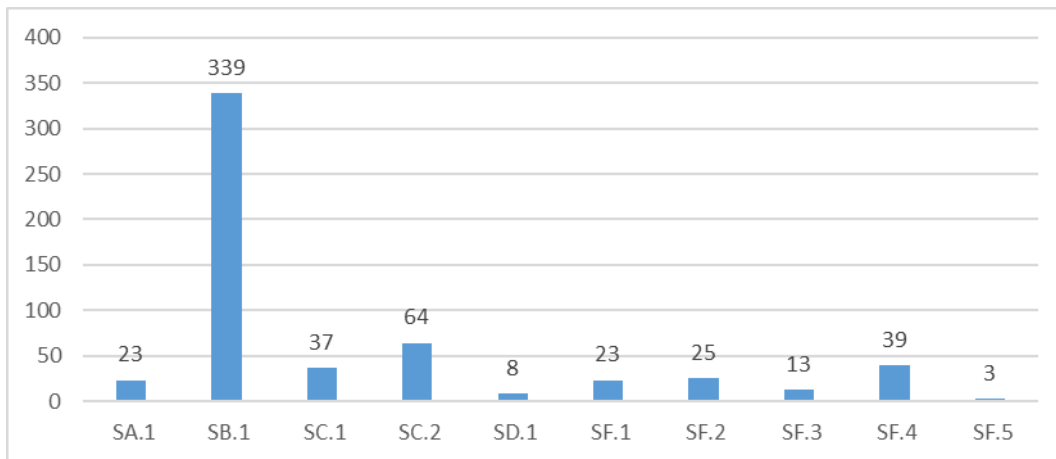

Source: Author

**Figure 38:** System elements available per system

However, the relevance of the information in the systems is at least as important as the amount of information contained. In fact, if the availability allows us to understand the information that can be exchanged, it is its relevance that enables us to establish priorities. Therefore, in the following figure we can see the relevance of each system, considering the system elements available. We can see that the most relevant system, considering all the risks, is system #1 from organization B (SB.1). Likewise, the system with less relevant information is system #5 from organization F (SF.5) .

**Figure 39:** Relevance of the systems considering the information available

Source: Author

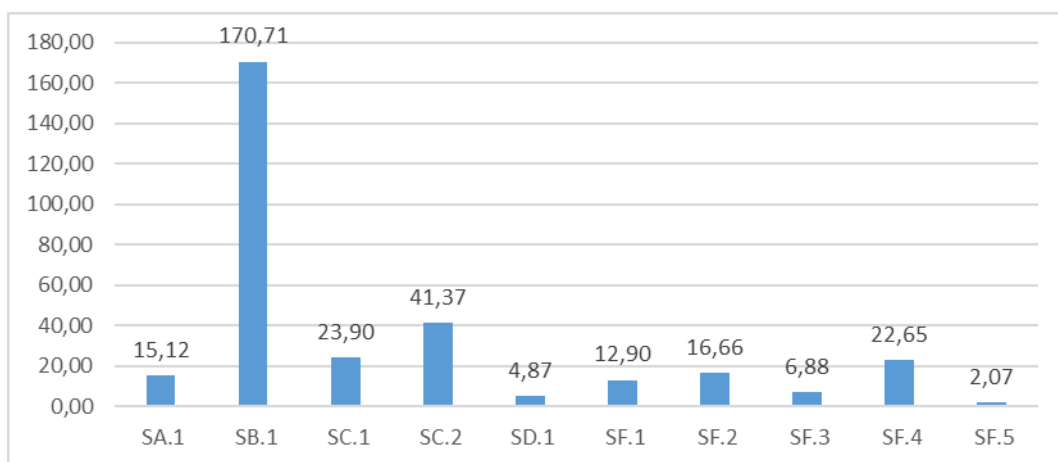

#### b) Information required

The system elements required by a system are those that implement CIM elements required by the organization. We have depicted these in the following figure, and we can see that the systems requiring more and less information are the same that have more and less information. In fact, the number of system elements available and required in each system is exactly the same. The reasons for this are the following. First, it is expected that each system element is relevant for the mission of the organization. Second, all organizations wanted to consume all information available in other organizations, mainly to enhance the quality and complement the existing information. Therefore, the column “required” in the questionnaire has this double meaning. In a different situation, we would need to create a different column in the questionnaire, to be more specific and explain, for example, that, although required for its mission, the organization was not interested in receiving similar information from other organizations (which we find unlikely, from our experience, but not impossible).

**Figure 40:** System elements required per system

**Source:** Author

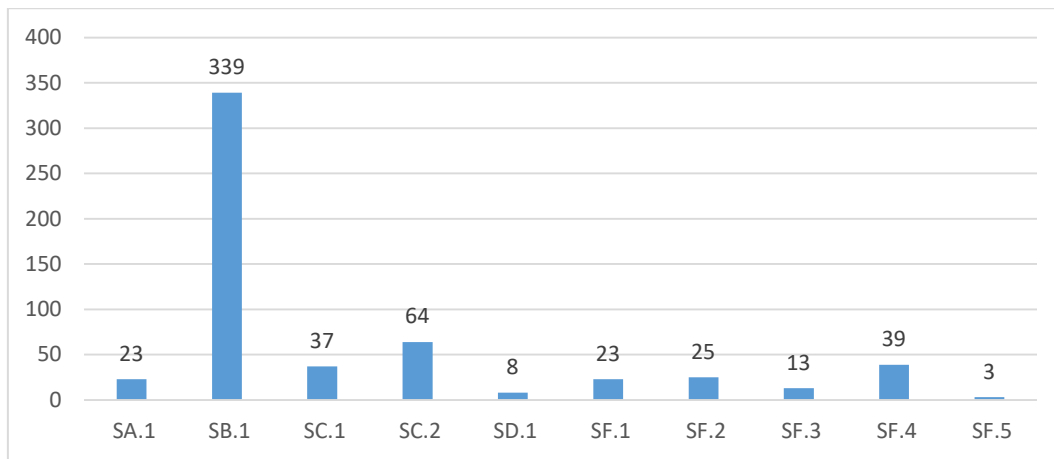

Consequently, the relevance of the information required by each system, as depicted in the following figure, is also the same as the relevance of the information available in each system, since this is based on the same system elements that have the same relevance individually.

**Figure 41:** Relevance of the systems considering the information required



Source: Author

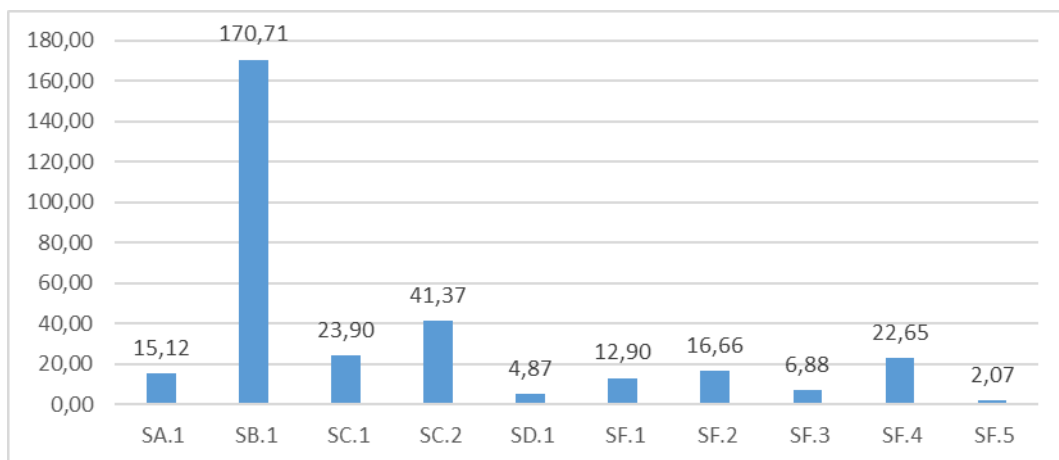

### c) Information to be provided

The information to be provided by a system depends on the information available on that system and on the information available (baseline) and required by the remainder systems. From the following figure we realize two important things. First, the amount of information that could be provided (RCP) by the systems is close to, in many cases, the information available (RA). Second, in all systems, the amount of information that could (RCP) and should (RSP) be provided is the same. The main reason for this is that systems are requiring all the information they can consume and because the type of information existing in the different systems is quite overlapping.

The fact that the type of information that could (RCP) and should (RSP) be provided in all organizations is the same, is very positive for the initiative, because it means two things. First, the information available by each organization is also of value to others. Second, it means that each organization will contribute to its maximum to the benefit of others.

**Figure 42:** System elements available and that could/should be provided per system

**Source:** Author

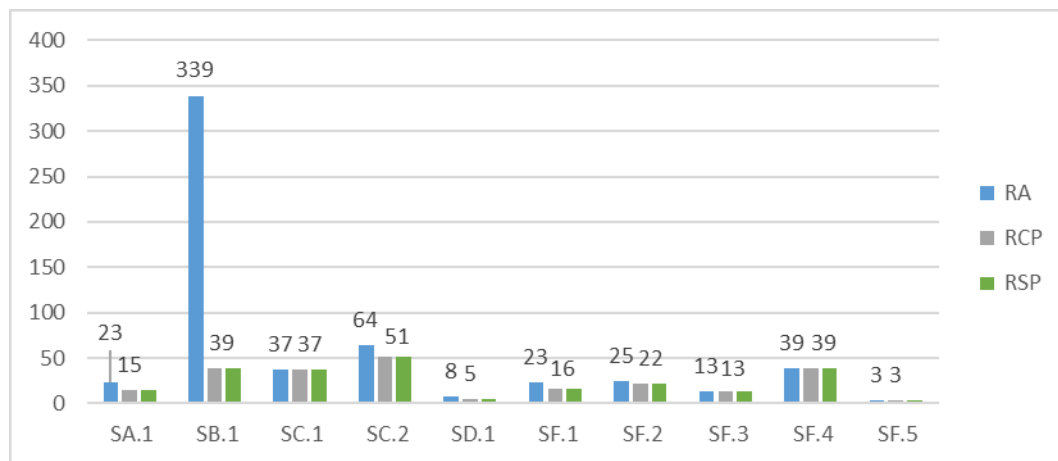

In the figure below, we can see the relevance of the different systems, considering the information available and that could and should be provided. In this case, we can see it is in line with the number of system elements.

**Figure 43:** Relevance of the systems considering the information available and that could/should be provided

Source: Author

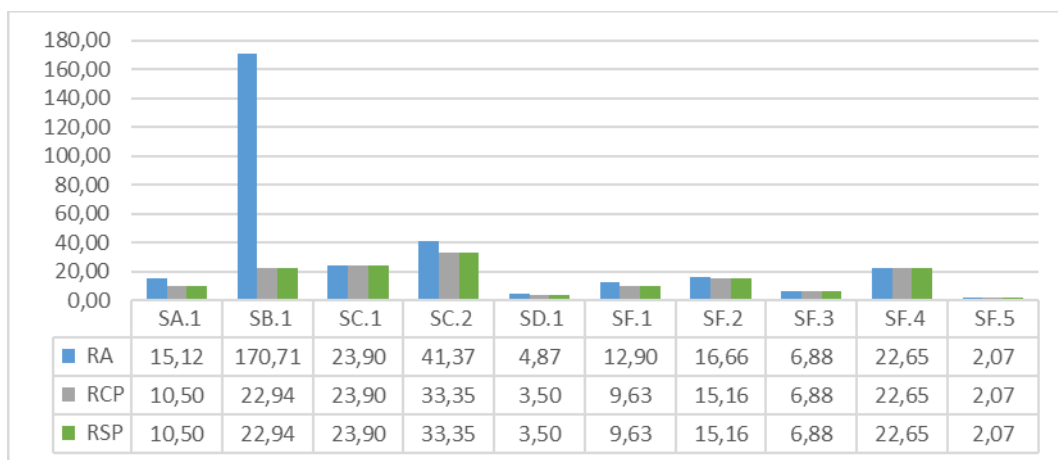

d) Information to be consumed

The information to be consumed depends of the information required by the system, of its ability to consume this information, and of its availability in the systems of the remainder organizations. As such, the situation of NIPIMAR, from this point of view, is depicted in the following figure. As we said, the information that can be consumed (RCC) is limited by its availability in other systems. Therefore, we can see that, in almost all systems, the information required (available and needed) (RR) is more than the information that can be consumed (RCC). The information that should be consumed (RSC) is, for all systems, the same that could be consumed (RCC), since all organizations are requiring the same type of information that they already have.

**Figure 44:** System elements available and that could/should be consumed per system

**Source:** Author

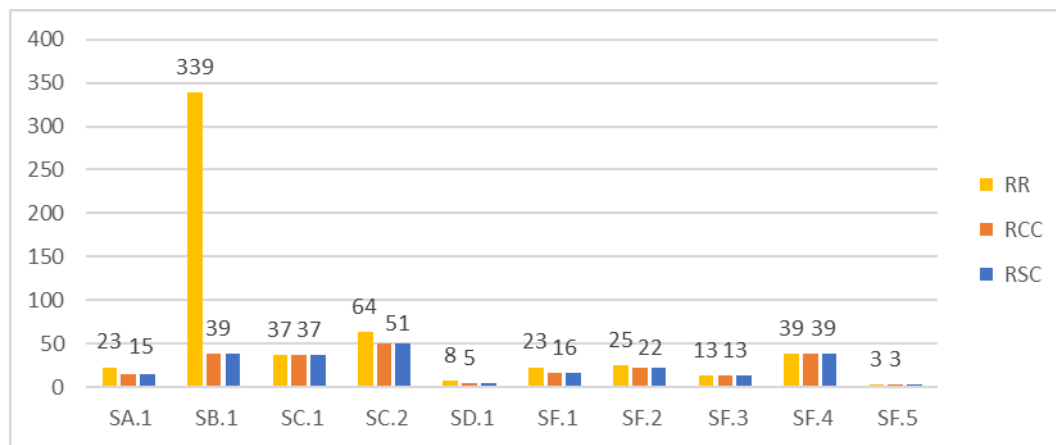

This is in fact a good thing, since it shows that organizations will be able to consume the totality of the information that they can, since it is available in other organizations, after semantic interoperability is implemented. Thus, meaning that a semantic interoperability initiative is worthwhile, in this case. Nonetheless, in some cases there is still information that although could be consumed, does not exist in other organizations (e.g. SA.1, SB.1, SC.2, SD.1, SF.1 and SF.2). Considering its relevance, these organizations may now analyze the possibility of developing new sensors to acquire it.

In the figure below, we can see that, in the various systems, the relevance of the information required, that can be consumed and that should be consumed is in line with the amount of information in each of the situations.

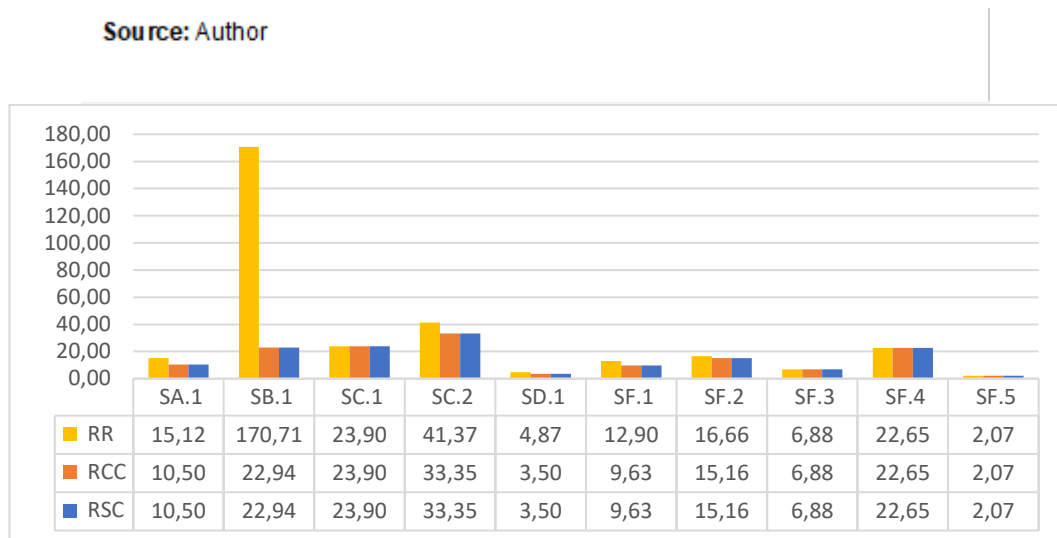
**Figure 45:** Relevance of the systems considering the information available and that could/should be consumed

### 7.3.2.2 Decision-making

#### a) Designing programs and projects

The most common situation that follows the determination of the semantic interoperability performance of a series of systems, participating in an information exchange initiative like NIPIMAR, is the definition of the actions that must be performed to improve that performance. Typically, such actions are firstly identified and then grouped into projects and programs according to various criteria. Consequently, we will now demonstrate how this can be done by using the components of the iShare framework. However, the solutions herein presented are not necessarily the best options for NIPIMAR, as we will only be as exhaustive as necessary to prove our points.

Therefore, the first step in this process is to identify the actions that must be performed to improve the present situation. There can be various possibilities, and often real cases require the combination of them. For example, if we would be looking to increase rapidly the exchange of information, we would implement all the semantic interoperability that is missing to exchange the information that should be exchanged (consumed and provided), thus increasing the information that must be exchanged. Another

option would be if we were looking to develop the amount of information that could be exchanged, in which case we would realize actions to implement, in the existing systems, the features necessary to consume the information required.

Considering the purpose of this demonstration, we will consider that our purpose is to increase rapidly the exchange of information, and thus our main objective is to implement the semantic interoperability that is missing to exchange the information that should be exchanged. To define the actions that we need to perform to achieve this objective, we will use the iShare framework concepts. Particularly, the actions that must be implemented are the implementation of semantic interoperability for each of the information elements, in all the systems of the participants, that should be exchanged (consumed and provided). These information elements correspond to our concepts RSC<sub>s</sub> and RSP<sub>s</sub> and are depicted in the following figure. The detailed information about these information elements can be found in appendix 12.

**Figure 46:** Number of information elements that should be exchanged per system

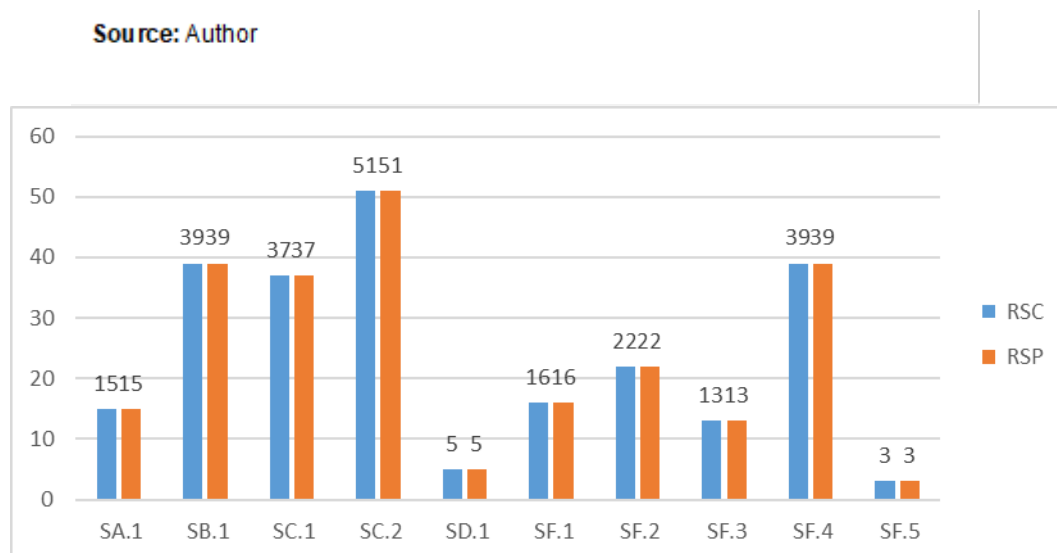

As we can see, the amount of information systems and elements involved is quite large and implementing semantic interoperability for all of them, simultaneously, would be a complex and long task. Therefore, to make the situation simpler, we prefer dividing this challenge into smaller parts. One of the usual ways to

do it is by creating multiple projects and aggregate them in a program. So, the challenge now is to determine how to divide the different actions by the different projects.

To achieve this objective, we will define several criteria, typically used in real situations. First, we wish to define a program with no longer than 3 years of duration and with 1 project per year. Then, we assume an average cost of implementation for each information element that must be implemented, and that the benefit of implementing each element is directly proportional to its relevance. By doing so, we are assuming that higher relevance benefits will always imply a higher return on investment. Then, we want the information elements that provide higher benefits (more relevant) to be implemented first.

We will also assume that there is no initial investment (e.g. technological infrastructure) in the first project, since this would make the number of information elements to be implemented in the first project much smaller. Then, we want all organizations actively participating and getting benefits from the beginning of the programme and in from as much projects as possible. Last, but not least, we must consider that the semantic interoperability must be implemented, for each information element to be consumed, in the corresponding information elements that should be provided. Otherwise, we would be implementing only a part of the necessary semantic interoperability, which would be insufficient to exchange the information.

Therefore, our approach will be as follows. Firstly, we will sort all the information elements that should be consumed (240), according to their relevance. Then we will divide the information elements into three groups (one to be implemented in each project), while trying to ensure that a similar number of information elements is implemented and that as many participants as possible are involved in each project. Finally, we complement each project with the information elements that should be provided that match the information elements that should be consumed previously selected.

After sorting, by relevance, the information elements that should be consumed, we obtain the result depicted in the following figure. We organized the information elements in nine intervals of relevance. In the figure, the relevance is between 0 and 1 and increases from left to right. The number of information elements in each interval of relevance is presented next to it.

As we can see, both the number of elements that have the highest (0.799 – 0.857) and the lowest (0.335 – 0.393) relevance are quite small, meaning two things. The first is that the number of elements that we need to implement to have a high impact, and therefore a high satisfaction of the organizations involved, is not so big. The second is that, if we implement the information elements following their order of relevance, the participants will get equivalent benefits from the projects they participate in, and thus will be interested in allocating resources and in participating during the whole program, which is essential to any information exchange initiative.

**Figure 47:** Number of information elements that should be consumed per intervals of relevance



Source: Author

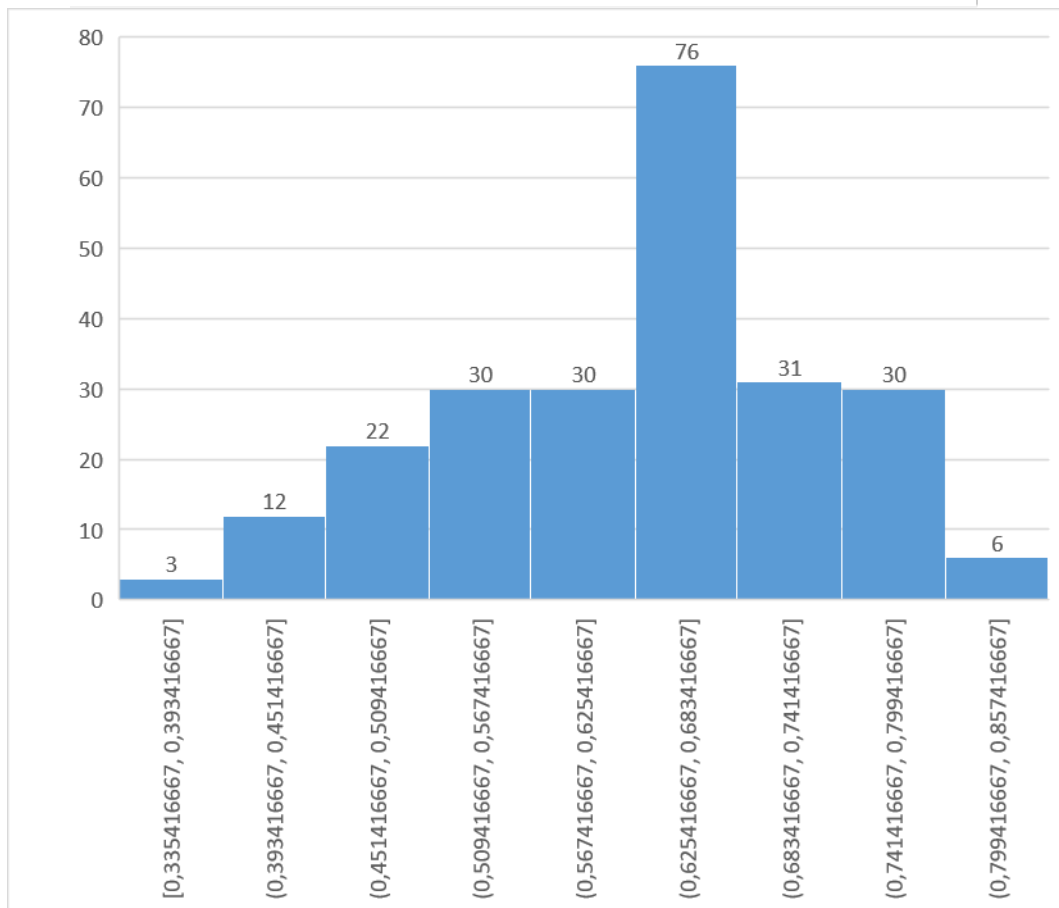

If we now equally distribute the number of information elements that should be consumed (240) by each project, each project would implement 80 information elements that should be consumed. To understand if we meet the requirement of having all organizations involved and getting benefits from all projects, we must consider that organization E is not willing to consume any information, and therefore only the remainder organizations will be in the list of consumers per project. In addition, we need to understand what is the minimum number of elements that must be implemented in all projects, so that most of the organizations (except E) get some benefit from participating in each project. This number is depicted in the following figure, and we can see that the threshold of 80 information elements per project fulfills this requirement also.

**Figure 48:** Minimum number of elements per project to involve all organizations

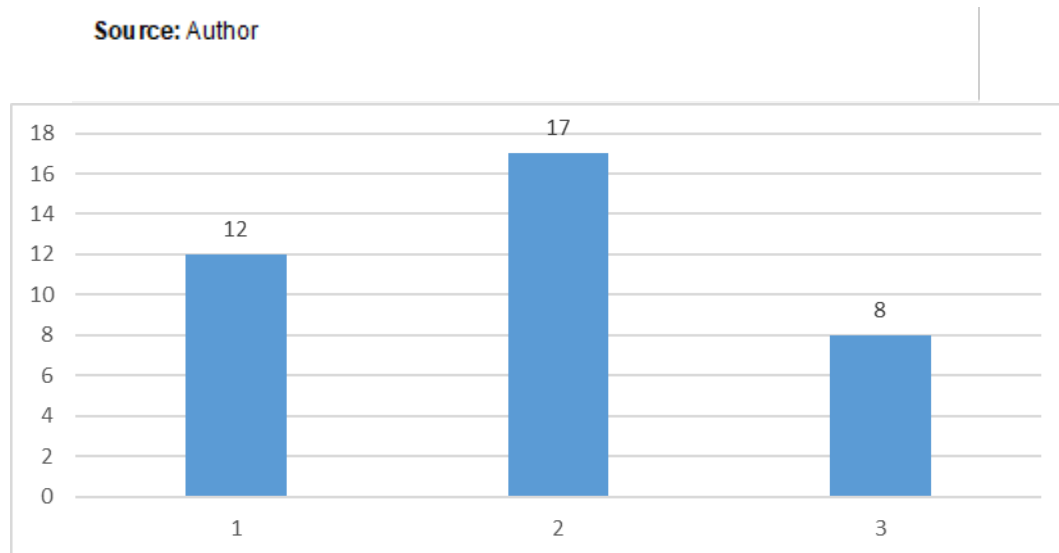

However, in the case of the third project, as depicted in the following figure, organizations A and D will not consume any information if only the relevance criteria is used to distribute the elements to be consumed across the projects. Therefore, to fulfill our requirement of keeping all organizations involved in all projects, we will exchange some of the activities of organizations A and D in projects 1 or 2 with

some of the activities of organizations B, C and F in project 3.

**Figure 49:** Number of elements each organization should consume per project

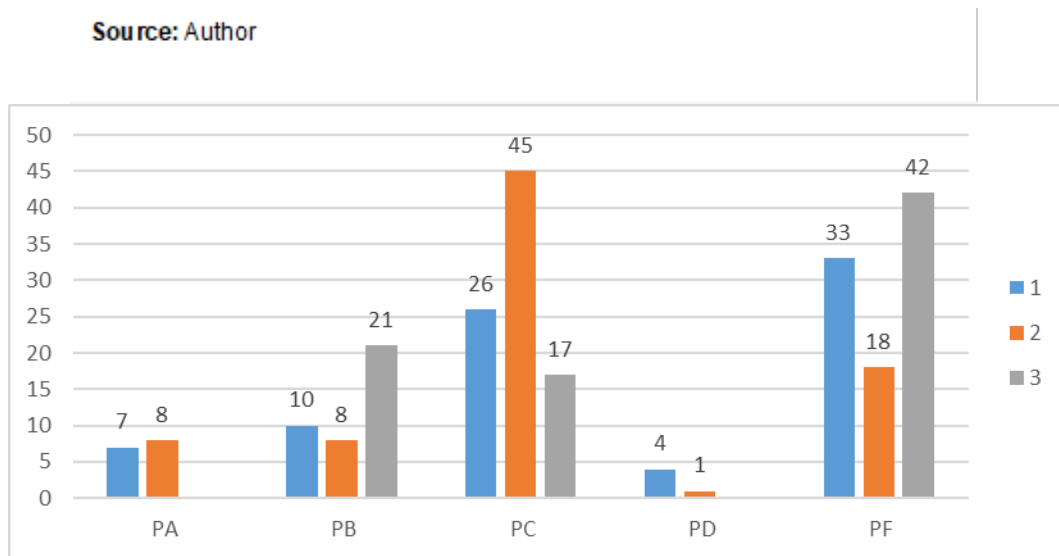

To do this, one option could be to approximate the number of elements each organization should consume per project, while maintaining the criteria of relevance and the same number of elements per project. Therefore, for organization A we could move 5 elements from project 2 to project 3 and 2 elements from project 1 to project 2. For organization D we could move 1 element from project 2 into project 3 and 2 elements from project 1 into project 2. In this case, the result would be that depicted in the following figure, where the number of elements per project would be unbalanced.

**Figure 50:** Total number of elements to consume per project

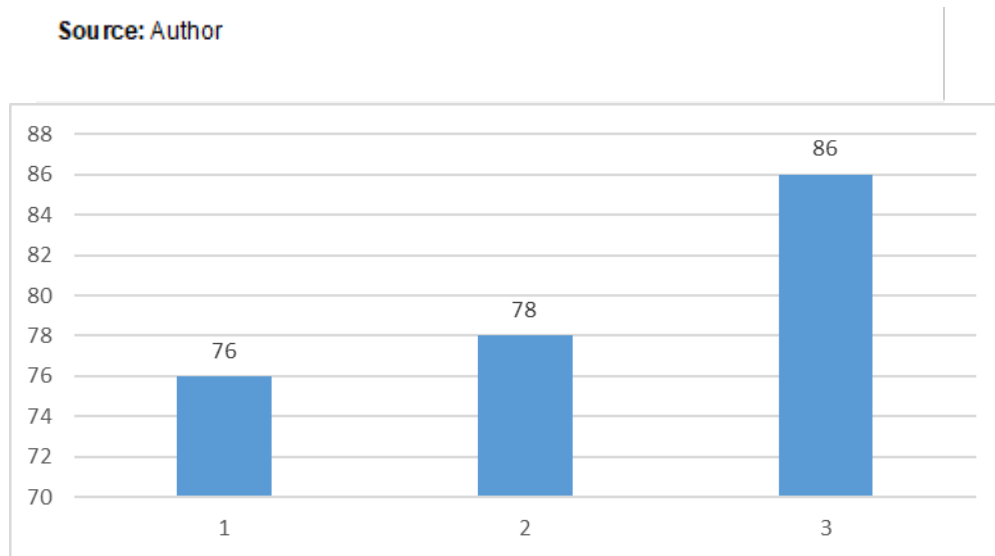

Therefore, to put again the same number of elements per project, let us look now at the benefit each organization is taking from each project. The idea is that organizations take more benefits in the first project, then less in the second and even less in the third project, although enough to keep them motivated to participate in all projects. However, as we can see, organizations A and D are well according to these criteria, but the rest not so much.

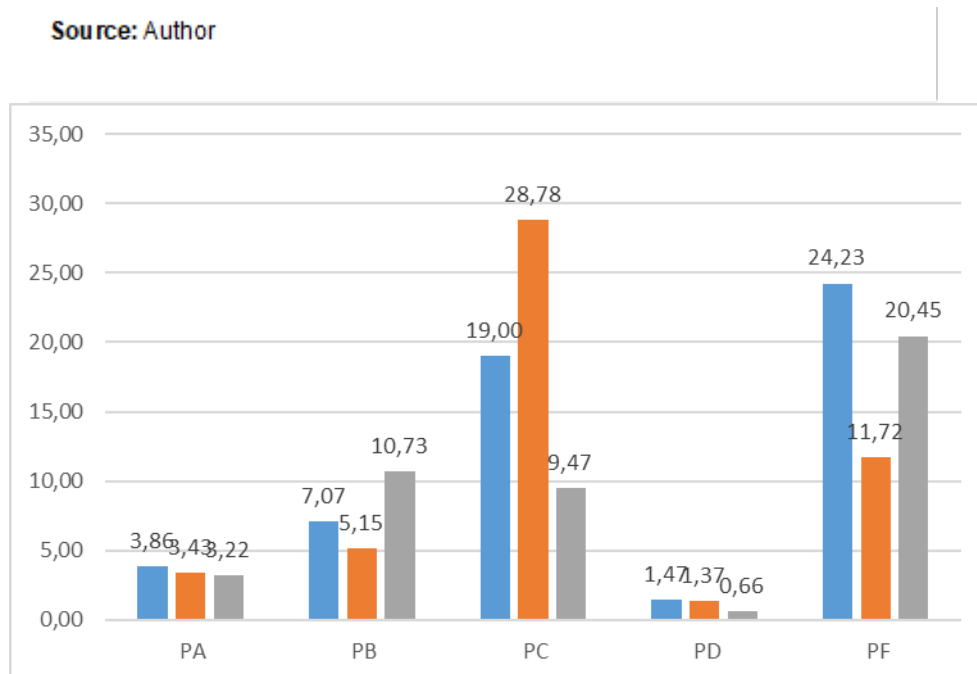
**Figure 51:** Relevance of the elements consumed per organization per project

Therefore, considering that we have to send some tasks (6) from project 3 to 2 and some other (4) from project 2 to 1, to balance the number of activities, we will now shift 4 elements to be consumed from organization C from project 2 to project 1, 3 from B from project 3 to 2 and another 3 from F from project 3 to 2. By doing so, we have now 80 elements to be consumed per organization, and the relevance (benefit) for each organization per project is as depicted in the following picture. As we can see, we have not yet achieved a downward trend of the benefits for all organization sin all projects, but to do that we would need to abide from having the same number of elements consumed per project. This trade off would have to be discussed among the stakeholders, but, for the time being, and considering the purpose of this demonstration, we will consider that the present distribution of elements to be consumed per organization per project and the corresponding benefits that each organization gets from it is good

enough.

**Figure 52:** Relevance of the elements consumed per organization per project

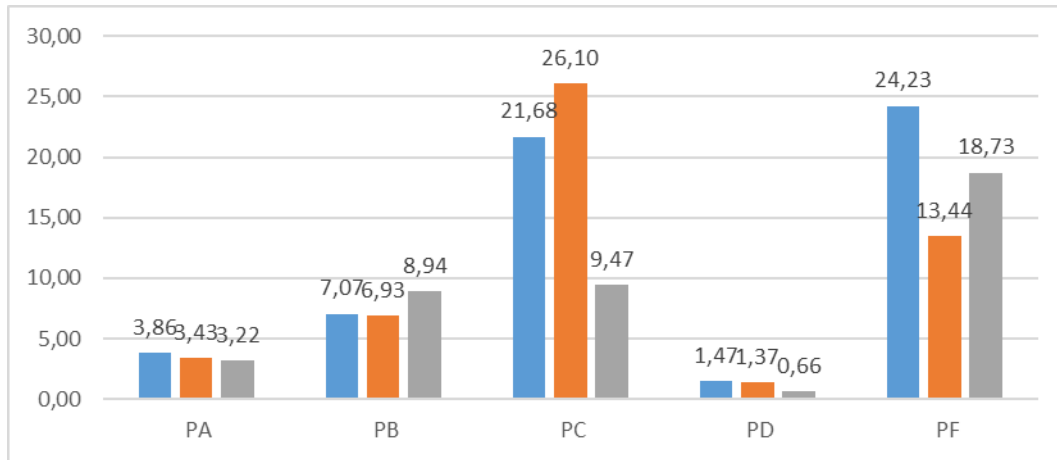

Source: Author

The number of elements to be consumed by each organization in each project is therefore as depicted in the following picture. The list of these elements, their relevance and the elements that should be provided in each project is depicted in appendix 14.

**Figure 53:** Final number of elements to be consumed per organization per project

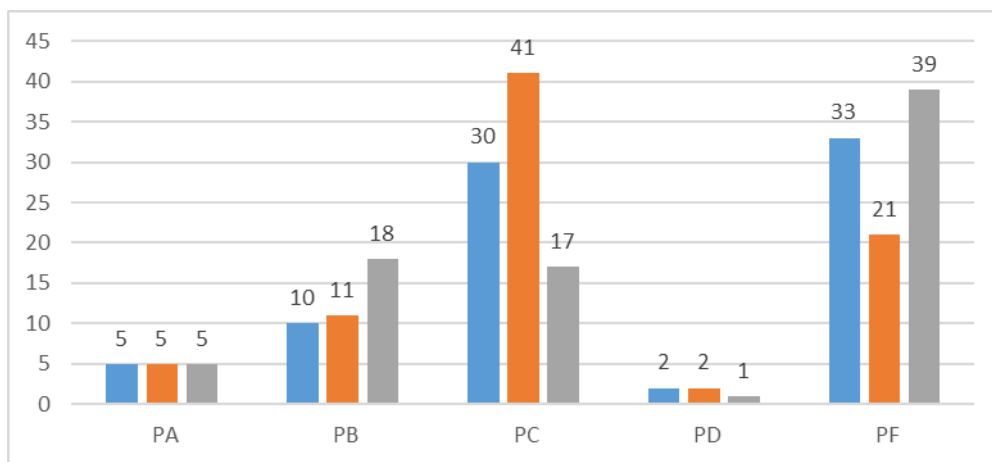

Source: Author

### b) Funding programs and projects

There are many initiatives ongoing in Europe to fund the development of interoperability among governmental agencies, and some of them are being developed to support the strategies and action plans we mentioned in chapter 2. For example, the European Integrated Maritime Policy is supported by the European Maritime and Fisheries Fund (EMFF), which has entailed several calls for projects in the fields of maritime information exchange and interoperability, at the European level, and also at the Member

States level (e.g. Portugal). Another example are the CEF Telecom projects (European Commission, 2018) that aim to support the development of Europe's Digital Single Market Strategy (European Commission, 2015a).

Generically, these initiatives start with the description of the challenge to be addressed by the projects, which is followed by the submission of proposals and by their evaluation. While developing the project proposals, typically organizations must specify, not only the project's outputs, but also their expected outcomes. To do this, the organizations involved in the proposal typically select a set of meaningful indicators, which they use to describe the present situation (baseline) and a set of targets that shall be achieved by the project. Moreover, they explain how the project's outputs will contribute to reach these targets. In addition, to simplify the evaluation process and to make the evaluations as much comparable as possible, typically a grid is used with the same criteria and relative weights. This grid is then applied to all projects in the same way, by the same evaluators, to ensure there is consistency in the evaluation process.

However, presently, and despite all measures in place, it is still hard to compare different projects when it comes to their contribution to improving the present situation. The reason for this is that organizations are free to choose the indicators to assess the success of the projects they are proposing. Therefore, if each project chooses a distinct set of indicators, it will only be possible to make a subjective comparison among them. Moreover, in this framework, there is not necessarily an alignment between the indicators being proposed and those of the policies being pursued. Consequently, an effective way to improve this would be for the call for proposals to include the indicators that should be used by all projects to describe the situation and define their targets. Like this, the indicators could also be aligned, from the beginning, with those used by the policies, and so strengthen the possibility of the outputs of the projects clearly contributing to the policies they aim to support.

Hence, this is where the iShare framework can help. By using it, policy officers can ask for project proposals to specify clearly, for example, the information that could, should and must be exchanged. Moreover, policy officers could also ask for project proponents to explain, in each proposal, how the information that will be exchanged will contribute to a pre-defined set of factors, that would be the same for all projects, and which would be aligned with the strategies the projects aim to develop.

For example, if we were to launch a call for projects for developing maritime information exchange in Portugal, and if we could only fund some projects, we would have to select the best. Therefore, in the call for projects, we could start by defining the business factors that projects would have to contribute to. Since we aim to use these projects to develop integrated maritime surveillance in Portugal, we would select the factors in line with the National Ocean Strategy (the same we used in the NIPIMAR project). Then, we would ask for each project to use the iShare indicators and to specify the baseline and the targets, as well as how each project would contribute to address the factors mentioned (relevance).

If the proposals follow these directives and reflect the situation described by our questionnaire, then the relevance and number of elements to consume in each program (3 projects of 1 year) of each organization would be as depicted in the following figure. In this situation, it is worth remembering that by implementing the proposed programs, each organization would completely fulfil its maritime information needs.

**Figure 54:** Number and relevance of elements to consume per program

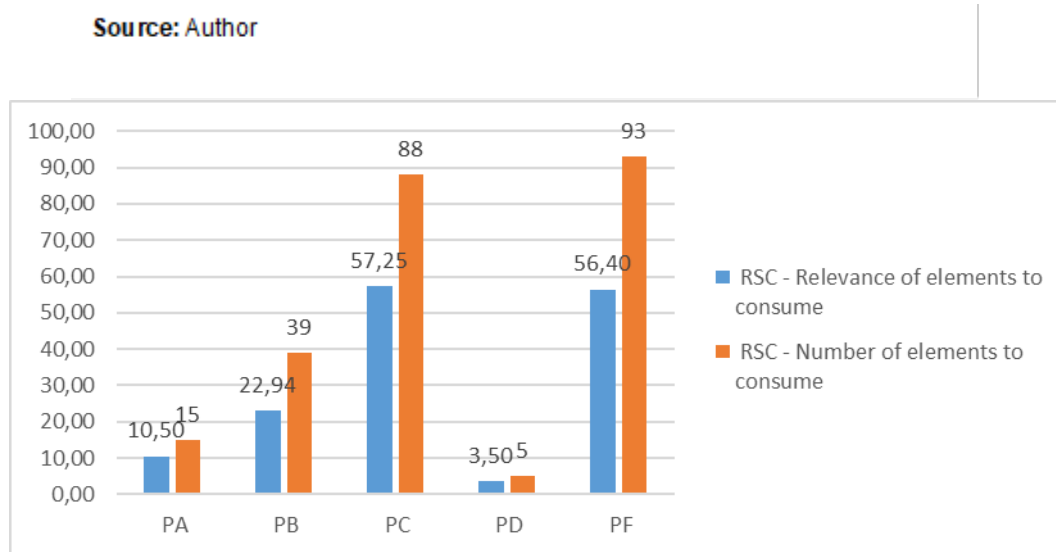

Consequently, we can see that although the programs which give us more benefit being those of organizations F and C, these are also the more expensive programs, assuming an equal cost per implementation of each information element. However, the programs where the average relevance per element is higher are the programs of organizations A and D, as depicted in the following figure. Therefore, in this case, we could decide among having more or less projects implemented, among implementing the projects that would give us more benefit, or among the projects with a better cost/benefit. Regardless of what the final decision could be, the bottom line is that this kind of reasoning is possible because we used the indicators of the iShare framework to support the program from the beginning.

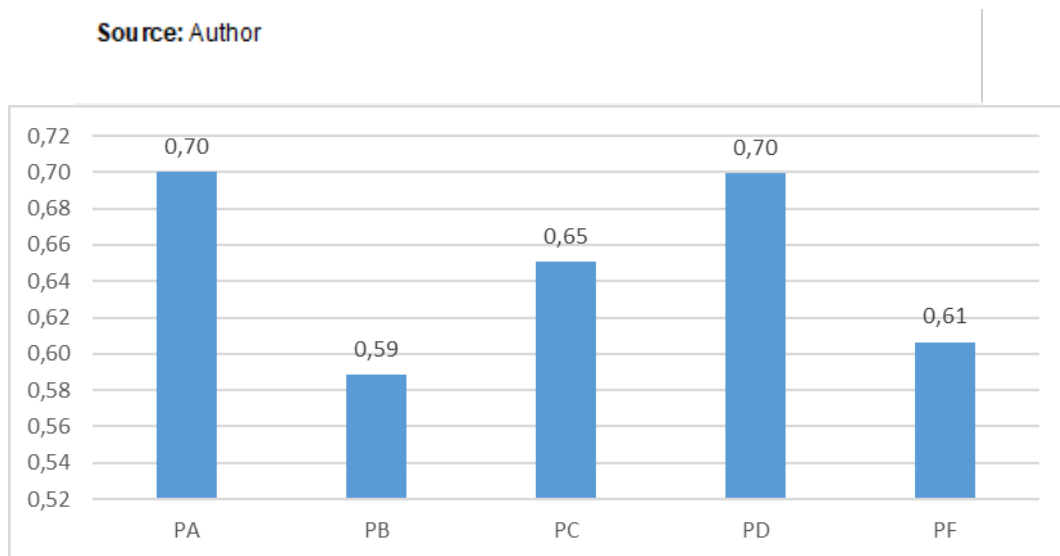

**Figure 55:** Average relevance of the elements to consume per program

### c) Managing programs and projects

After design and approval, projects are started, and their progress has to be monitored and reported. This is a best practice in program and project management and it is essential to ensure that the resources are well used and that the results are achieved according to the expectations, which is typically within the time, budget and quality objectives specified.

Besides these traditional monitoring activities, it is also important to monitor and control the outcomes of the project. After all, the purpose of making projects is to change the situation into a preferred one. Therefore, monitoring the outcomes is very important to keep the project beneficiaries involved, motivated and thus supportive.

Although in traditional project proposals the organizations include several indicators for monitoring outcomes, that are used throughout the project lifecycle, if they use indicators from the iShare framework this will enable the comparison of the progress of the different projects, which could be interesting in the case of a program or in the case of a funding initiative that is supporting multiple projects, which

outcomes we wish to track in a normalized way for comparing them.

Therefore, as an example, we could simulate that, based on the previous example, we funded the programs proposed by all organizations. We recall that each of these programs is composed by three projects with a duration of 1 year each, during which several information elements will be consumed by each of the organizations.

As such, in the figure below we drew a baseline, that corresponds to the evolution of the number of consumed elements per organization, over a three-year timespan. In this figure, the individual projects are not represented, but we know that each project corresponds to 1 year. Now that we have this baseline, we can use the same indicator to keep track of the number of elements that is being consumed every time the assessment is made, and compare it with the baseline, to check if the progress of the program, in terms of outcomes is according to the expectations. Moreover, by using the same iShare indicators for assessing the outcomes of all programs, we can now compare them as well.

**Figure 56:** Evolution of the number of elements consumed per organization

Source: Author

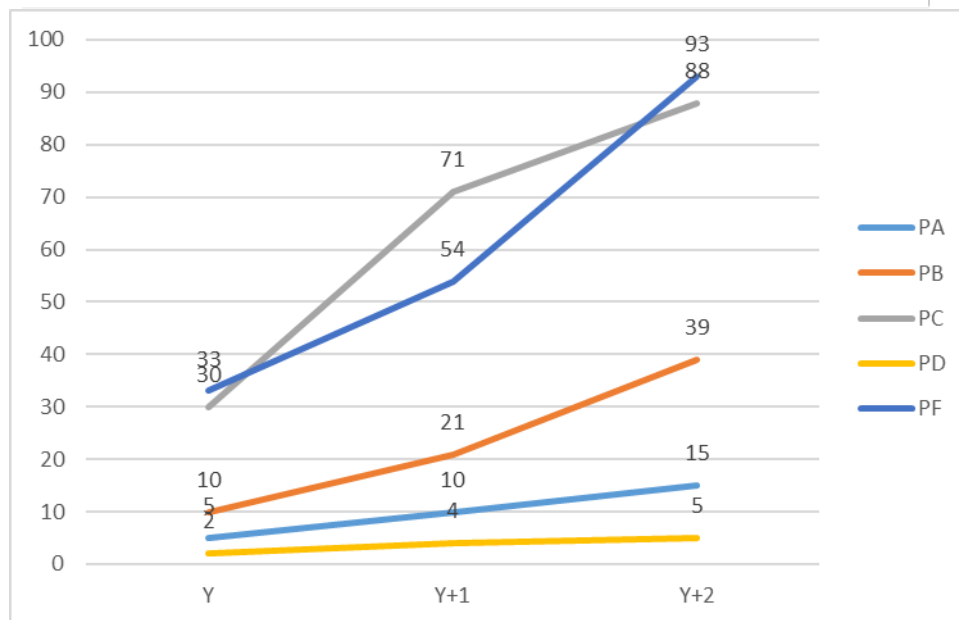

Likewise, we can define the outcomes of each program in terms of its relevance to the respective policy, and define the baseline for their evolution, as depicted in the following figure. Again, every time we assess the situation of a project, we can compare the relevance of the information being consumed to the relevance of the information that should be consumed by that time, and so realize the benefits of each program. Moreover, since we are using the same indicators for all programs, we can now compare them as well, which would not be possible if the programs used different indicators for the outcomes, instead of the indicators of the iShare framework.

**Figure 57:** Evolution of the relevance of the information consumed per organization

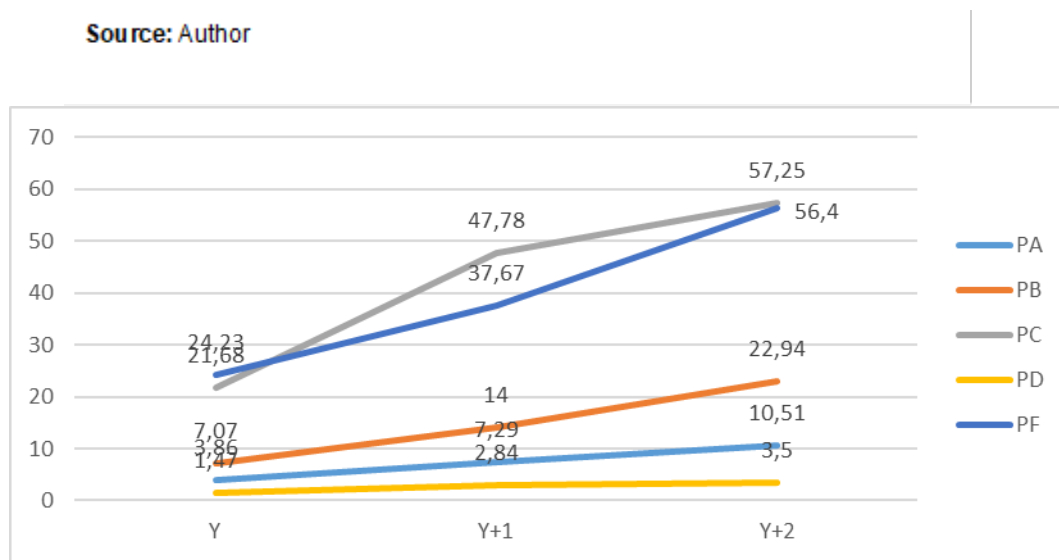

### 7.3.3 Evaluation

In general, the artifacts created in Design Science Research must be assessed against criteria of value or utility. According to the methodology we followed, this is done in the evaluation phase, during which the objectives defined for the solution created are used as base for comparison with the achievements. Therefore, we will now evaluate the iShare framework, according to the objectives defined earlier.

#### 7.3.3.1 Effectiveness objectives

One of the purposes of the iShare framework is to be effective. Concretely, we would like it to achieve five different objectives in this regard. Three of them are related to the effectiveness in assessing the semantic interoperability performance of an organization, and the other two are related to the effectiveness in assessing the relevance of that performance.

The first objective of the iShare framework is to enable determining the present semantic interoperability performance of an organization. In this regard, first, in section 5.1, we have used the iShare framework to determine the semantic interoperability performance of several organizations in an artificial scenario, and then, in section 7.4.2.1 we used again the iShare framework to determine the semantic interoperability

performance of the organizations involved in a real situation - the NIPIMAR project. In this regard, it was possible to determine all the components of the framework. However, the result of some indicators, those relative to the actual semantic interoperability, was zero, because the project is still in an early stage, and so there is no semantic interoperability implemented between the systems of the organizations and the CIM. Nonetheless, we consider that this objective was achieved, since the indicators portrayed the present situation correctly.

The second objective is to enable determining the desired semantic interoperability performance of an organization. As such, we have used the iShare components, in section 7.3.2.2, to define the semantic interoperability objectives that should be achieved by future projects in the context of NIPIMAR. Moreover, we have used the iShare components to compare the level of ambition of various projects, in terms of semantic interoperability, and to make decisions regarding which should be funded in an imaginary funding program for developing semantic interoperability. As such, we conclude that this objective has been achieved.

The third objective is related to the first two and regards using the iShare framework to determine the possible semantic interoperability performance of an organization. As we have seen, there are various limits for developing semantic interoperability, such as the necessary features being implemented in the systems that are going to consume the information, for example. Therefore, the possible semantic interoperability is not the maximum, but what can be achieved under the circumstances. Again, in section 7.3.2.2 we used the iShare components to determine the possible semantic interoperability performance of the organizations involved in NIPIMAR, so that all could understand the limits of what could be achieved if there were no further changes. As such, we conclude that this objective has been achieved.

The fourth objective is related to the iShare framework enabling us to determine the relevance of the of the present semantic interoperability performance of an organization. This objective is very much related with objective number one, since without determining the performance, it would not be possible to determine its impact. We used the iShare components for this purpose in two occasions. First, in section 5.2, during the demonstration of the components, with the scenario. And second, in section 7.3.2.2., with the organizations involved in the NIPIMAR. As such, we also consider that this objective has been achieved.

Finally, the last objective related to the iShare framework is that it should enable the determination of the relevance of the desired semantic interoperability of an organization. Since we have done this in section 7.3.2.2, while defining the various projects that should follow, to increase the semantic interoperability of the organizations involved in the NIPIMAR, and later, in the same section, to compare different projects and to manage different projects, we consider that this objective has also been achieved.

### 7.3.3.2 Efficiency objectives

Regarding efficiency, we have defined three objectives for the iShare framework. The first is related to the size of the initiatives in which it is supposed to be used. The second regards its cost-effectiveness and the third is that it should enable the consensus of the organizations involved.

The iShare framework is not meant for small scale initiatives. By small scale initiatives we mean those that involve little over than a couple of organizations, few systems and information elements. The iShare framework is more suitable for initiatives with the opposite characteristics, where problems tend to arise related to the complexity, duration, scarce resources and disagreement and demotivation of the organizations.

Therefore, the first objective is that it should be appropriate for large scale initiatives. Since we demonstrated its use in the NIPIMAR project, involving multiple organizations and systems, and a common information model with around 700 information elements, we consider that this objective has been achieved.

The second objective of the iShare framework related to efficiency is that its use should be cost-effective. From our experience using it during the NIPIMAR project, we learned that the biggest cost comes from the part where experts from the various organizations have to analyze and evaluate the information from the common information model. This usually takes time, and the larger is the information model and the number of factors considered to assess its relevance, the more time this will take. Another time-consuming activity can be that of achieving consensus among the different organizations, regarding the relevance of each information element in the common model, although this has not been our case. In any case, the benefits achieved with using the iShare framework largely exceed its cost. We have developed insights about the situation and instruments for better managing its evolution that did not exist before. So, we consider that this objective has been achieved as well.

Finally, the last efficiency objective of the iShare framework is that it should be able to generate consensus among the different organizations involved in the process. In fact, the relevance of the information elements of the common model is a key element of the framework. This is the feature that will help in prioritizing and in justifying them, and so it must be defined by consensus. If all organizations agree on the value of the information, then all activities that follow will be agreed by them. Otherwise, it will be very hard to explain why some activities will be implemented instead of others and this will undermine the trust among the organizations involved, which is essential for them to exchange information. Promoting consensus is therefore essential to the transparency of the initiative, and the iShare framework supports this because, at its core is the Delphi method, and so it comprises as much iterations as needed for this to occur. We have demonstrated this within the NIPIMAR project as well, and so we consider that this objective has been achieved.

### 7.3.3.3 Quality objectives

The last objectives we defined for the iShare framework are those related to quality. Usability, independence and flexibility are three important characteristics that the method should have, to cope with real world situations and to be applicable to different domains.

As such, the first objective is that the iShare framework must be easy to use. While the definition of its components might seem complicated at first, it is essential for its wide adoption. On the other hand, as soon as these are implemented by a tool, and the main ideas understood, putting them into practice is not difficult at all, and this was one of our main concerns while developing the framework. As we demonstrated in the previous sections of this chapter, as soon as the information is collected it is very easy to build a dashboard or some other sort of decision support tool that allows us to easily make the necessary decisions regarding how the semantic interoperability must improve. An example of a possible dashboard was presented in appendix 5, from where we can see that the complexity of this tool is not at all evident when the moment comes to use it. As such, we consider that this objective has been achieved.

The second objective is that the iShare framework must be independent from the specific domain and case of application. We have designed the framework so that it could be easily customizable. The parameters to do it are not much more than an information model and a set of factors to determine the relevance of this information. We have customized the framework while we were demonstrating it with the artificial scenario, and again while demonstrating it in the NIPIMAR project. The behavior of the framework was completely independent of the parameters introduced, and even the software developed for automating part of the calculations did not require changes other than selecting the right parameters for each case. Therefore the iShare framework does not depend from the domain of application used for its demonstration and may be used in other domains.

Finally, the iShare framework must be able to adapt to organizational and context changes. Beside the fact that the framework can be completely reconfigured, as we explained earlier, minor tunings are also possible. When we thought of this requirement, we were mainly thinking that political priorities change over time, and so does the importance of the factors used to evaluate the information. We were also thinking that more information could be available in the future that is not presently implemented in the common information model. As such, and in relation to the first case, we can add, remove or replace the factors that are used to evaluate the information, and even and change their relative weights. Regarding the second case, we can also change the information elements as necessary, to cope with new realities. We have not demonstrated this in the NIPIMAR project, because it would not be realistic. However, the fact that we used the framework in two different settings in a seamless way, is a good evidence that these features are supported. As such, we also consider that this objective has been achieved.





## Conclusions

The exchange of information among governmental agencies is essential for their efficiency and effectiveness. First, whenever governmental agencies do not exchange information among themselves, they tend to develop alternative capabilities to collect the information they need, which leads to unnecessary investment and maintenance costs. Second, the information received from other agencies can help in improving the quality and in eliminating gaps in the information available, both of which have the potential to improve the result of their actions. Finally, more information brought together can lead to new insights which, in turn, will lead to better policies and to a more proactive posture.

But developing the information exchange among governmental agencies is not an easy task. There are several reasons that contribute to this; political, legal, organizational and technological. One that particularly affected us, in the past, was the lack of management instruments to do it. After being involved in multiple initiatives, at the national and European levels, related to the development of information exchange among governmental agencies with responsibilities over the maritime domain, we kept facing the same problems. On the one hand, the arguments in favor of the exchange of information were mostly subjective, while its costs were very clear, and the reason for this was a simple one – there were no ways to measure it more objectively. Consequently, it was always very difficult to justify information exchange initiatives, to motivate the organizations to get involved and to assess the results, which hampered the necessary evolution. On the other hand, without such instruments it was very hard to follow and even more to compare the results of different projects in the same initiative, because the indicators used for this could be completely different.

Information exchange relies on the interoperability of the organizations involved. But this is another complex topic, because interoperability must be implemented in various levels - the political, the organizational, the legal, the technical and the semantic. So, assessing the needs, benefits and results of interoperability among governmental agencies, although essential to develop the exchange of information among them, it is also a very difficult task. On the other hand, a critical aspect of information exchange is that, despite the solutions adopted at the various levels, it must be ensured, at all times, that the meaning of the information exchanged between the different parties is preserved at all times, which is ensured at the semantic level.

Consequently, we decided to contribute to a more objective assessment of information exchange and interoperability, by developing a framework for assessing the semantic interoperability of governmental agencies, which was lacking in the scientific and grey literatures. With this purpose in mind, it became clear since the beginning that it was not enough to develop a way to determine how much interoperability existed. This tool had to be more ambitious and allow us to understand how relevant the existing semantic interoperability was, and which would be the benefits of increasing it. Moreover, this tool had to allow us to establish comparisons among different initiatives to establish priorities and to help us in defining

achievable levels of ambition regarding how much it could be improved.

With these objectives in mind, we followed the strategy that seemed most appropriate for conducting this kind of research – Design Science Research. Being adequate for developing innovative artifacts that increase the existing knowledge and for allowing managers to improve the existing situations, this strategy fitted perfectly in our intentions. As such, we followed it and developed what we called the iShare framework – a set of indicators and other components, based on set theory and on the Delphi method. The objective of our framework is to assess the semantic interoperability of different organizations, willing to exchange information among themselves, by using a common information model. The iShare framework was validated in a real initiative comprising several Portuguese governmental organizations, different information systems and a common information model for the exchange of maritime surveillance information at the European scale.

The iShare framework is innovative, useful and relevant. It is innovative because, as demonstrated during our scientific and grey literature review, there is nothing similar or that can achieve the same objectives. Existing approaches to measure semantic interoperability are mostly focused on how semantically close different information models are from each other and on how much organizations follow certain standards or guidelines that contribute to their semantic interoperability. Our approach, on the other hand, is focused on how much semantic interoperability has been achieved, despite the technique used to do it, and assumes that a common information model (more cost-effective approach) is used for the exchange of information among the different parties.

The usefulness of our approach was demonstrated by applying it to a real situation – the NIPIMAR project. The iShare framework was not immediately adopted by the project, because it was not part of its scope, but its concepts influenced its development and were reflected in its results. Moreover, there is the possibility that, in the future, our framework, or at least part of it, can be used systematically in the NIPIMAR project. Finally, information exchange and interoperability are hot topics in many different domains with impact at various levels, including social, economic and environmental. Therefore, a tool that contributes to foster the development of interoperability and information exchange among governmental agencies is inherently relevant.

The iShare framework contributes to the body of scientific evidence, since it is useful and fundamental in understanding the semantic interoperability among organizations and its relevance and contributes to improve the managers' capability to change the existing situations into preferred ones. With the iShare framework it is now possible to understand the present performance and relevance of the existing semantic interoperability among different organizations. Moreover, it allows us to know how much semantic interoperability can be achieved, to develop new initiatives to do it and to manage them. This was demonstrated during the evaluation of the framework, against the objectives defined.

The iShare framework is a solution that satisfied us, in supporting us to overcome the challenges faced when assessing the performance impact of the semantic interoperability among different governmental organizations and managing its evolution. However, it can certainly be improved. For example, more indicators may be created to support aspects that were not captured during this first experimentation. However, for the time being, we achieved our objectives and managed to provide ways to improve the existing semantic interoperability situation. Presently, with the iShare framework, the manager of an interagency information exchange initiative can have much more control over its evolution and has much better arguments to support its decisions than before.

Another important feature of the iShare framework is that it is completely independent from the examples and project where it was demonstrated. All its components are abstract and must be instantiated for every application. In fact, this was one of our main objectives while developing the iShare framework. We wanted it to be applicable in other situations and in different domains.

Consequently, the iShare framework satisfies the necessary requirements to qualify as a valid research work. It is a new artifact that was created to address a specific problem. Its utility was explained, and it was appropriately evaluated. It increases the professional and scientific knowledge in the area, is suitable for its intended usage and satisfies the criteria proposed for its development.

However, the iShare framework still has some limitations. For example, the time taken to compile the different answers to the questionnaire and to analyze them was very long. To facilitate the analysis part, we developed a software component, which although useful, is only a prototype. In the future, we think that the implementation of a tool that can automatically collect the information and produce the results would be an added value for any information exchange initiative, and one that would largely decrease the time consumed into this exercise, and so increase the cost-effectiveness of the iShare framework, since with less effort we could obtain the same results.

In addition, we assumed, during the questionnaire performed in the NIPIMAR project, that all the information needed by an organization to conduct its mission was also to be consumed from another organization, if it was available in the systems of both organizations. However, we concur that this might not always be the case. Therefore, in future utilizations of the framework, the questionnaire should make this aspect clearer.

Therefore, we have developed an artefact to assess the performance and relevance of the semantic interoperability of organizations that are willing to exchange information with other organizations by using a common information model. Hence, we have validated the hypothesis and answered the research questions stated in chapter 2.

As said above, the iShare framework represents some progress towards the assessment of interoperability

and information exchange among governmental agencies. But there is still a lot of work to be done in this regard. The indicators of the iShare framework bring us a quantitative perspective of semantic interoperability, which makes now possible for researchers to start using the data collected with them to understand better the phenomenon in all its variants. Future research questions could be explored in different scientific domains. In the social domain, it would be interesting to study the willingness organizations to exchange information. On the technological domain, it would be interesting to understand the challenges posed with more information being exchanged among governmental agencies. On the legal domain, on the other hand, would be interesting to understand the requirements of a good legal framework to support adequately the interagency information exchange. Finally, at the organizational level, it would be interesting to understand the relationship between information exchange and operational effectiveness and efficiency, also including the IT point of view.

Although the iShare framework is not bound to any specific domain, our professional background is the maritime domain, and it was our experience while trying to develop the information exchange in this domain that motivated us for doing this research. Therefore, now that our work is complete, we cannot avoid looking at the instrument that we have just developed and thinking about the role it can have in the future of the maritime domain. Presently, the maritime transport is the backbone of global trade and of global economy, which, according to Mr. Ban Ki-moon, former UN Secretary General, makes shipping indispensable to the world. In this context, shipping is going through many important transformations, out of which we highlight two that we consider highly disruptive, in the sense that they will most likely change completely shipping as we know it.

The first of these transformations is the digitalization of shipping. The advance in computer systems ashore and onboard vessels and the ever-increasing number of ships connected to the internet, are the cornerstone for the automation of business processes where speed and reliability is paramount. These systems and connectivity will enable faster decision making and corrective actions that were not possible before, hence increasing the overall efficiency and effectiveness of maritime transport. For example, the digital twins of real ships will enable any aspect of the vessel to be monitored in real time and so controlled and optimized through a digital interface.

The second transformation we highlight is the advent of autonomous ships. Soon, vessels equipped with reliable computer systems and artificial intelligence will be cruising the oceans autonomously. This implies a radical change in the ships themselves, which will have to obtain and process all the information necessary to carry out a safe navigation. Moreover, it implies a radical change in the aids to navigation, that presently are designed to be identified and interpreted by humans and that, as soon as these autonomous ships start cruising the oceans, will have to be enhanced to interact with these machines and to support their navigation seamlessly. Finally, autonomous ships will also imply smarter ports, able to interact with such intelligent ships and to cope with their capabilities. In this future, the best port will be

the one that is able to take the most out of these new ships, and thus to contribute adequately to gains of efficiency in the whole supply chain.

There is, though, something that is crosscutting to these two disruptive innovations that will shape the future of shipping – the need to exchange information. The introduction of more and brighter computer systems highly interconnected in the shipping business implies that these computer systems, belonging to different organizations, will have, more than ever, to exchange information in an efficient and effective manner. These systems will have to be interconnected, and priorities will have to be defined regarding which information will be exchanged first and why. Consensus will have to be reached among the stakeholders in this regard. Funding decisions will have to be made, in face of the various possibilities. And all of this will have to be done periodically, since the technology will evolve, the systems will be modernized, the business requirements will change, and the information exchange solutions will have to follow up. Consequently, instruments will be required to properly manage this evolution, and so we conclude that the iShare framework can have a key role in the future of shipping, which is evermore important to the world.

(page intentionally left in blank)

## References

- Abdul-Ghafour, S., Ghodous, P., & Shariat, B. (2012). Integration of product models by ontology development. In *13th International Conference on Information Reuse & Integration (IRI)* (pp. 548–555). IEEE. <https://doi.org/10.1109/IRI.2012.6303057>
- Abdul-Ghafour, S., Ghodous, P., Shariat, B., Perna, E., & Khosrowshahi, F. (2014). Semantic interoperability of knowledge in feature-based CAD models. *Computer-Aided Design*, *56*, 45–57. <https://doi.org/10.1016/j.cad.2014.06.001>
- Agile Alliance. (2001). Agile Manifesto. Retrieved May 4, 2018, from <http://www.agilemanifesto.org>
- Akbulut, A. Y., Kelle, P., Pawlowski, S. D., Schneider, H., & Looney, C. A. (2009). To share or not to share? Examining the factors influencing local agency electronic information sharing. *International Journal of Business Information Systems*, *4*(2), 143. <https://doi.org/10.1504/IJBIS.2009.022821>
- Andersen, B., Ulrich, H., Kock, A.-K., Wrage, J.-H., & Ingenerf, J. (2014). Semantic interoperability in the OR.NET project on networking of medical devices and information. A requirements analysis. In *IEEE-EMBS International Conference on Biomedical and Health Informatics (BHI)* (pp. 428–431). IEEE. <https://doi.org/10.1109/BHI.2014.6864394>
- Andersen, D., & Dawes, S. (1991). *Government Information Management: A Primer and Casebook*. Pearson College Div.
- Arch-int, N., & Arch-int, S. (2013). Semantic Ontology Mapping for Interoperability of Learning Resource Systems using a rule-based reasoning approach. *Expert Systems with Applications*, *40*(18), 7428–7443. <https://doi.org/10.1016/j.eswa.2013.07.027>
- Association for Ontology Design & Patterns (ODPA). (2009). DOLCE+DnS Ultralite. Retrieved May 14, 2018, from [http://ontologydesignpatterns.org/wiki/Ontology:DOLCE%2BDnS\\_Ultralite](http://ontologydesignpatterns.org/wiki/Ontology:DOLCE%2BDnS_Ultralite)
- Australian National Audit Office. (1999). *Electronic Service Delivery, including Internet Use, by Commonwealth Government Agencies. Audit Report No. 18 1999-2000. Performance Audit*. Canberra, Australia: Australian National Audit Office. Retrieved from [https://www.anao.gov.au/sites/g/files/net616/f/anao\\_report\\_1999-00\\_18.pdf](https://www.anao.gov.au/sites/g/files/net616/f/anao_report_1999-00_18.pdf)
- Bacchelli, F., Boury-Brisset, A., Isenor, A., Kuehne, S., Martinez, B., Miles, J., ... Wunder, M. (2010). *Semantic Interoperability. RTO Technical Report RDP. RTO-TR-IST-075. AC/323(IST-075)TP/315*. Retrieved from <https://www.sto.nato.int/publications/pages/results.aspx?k=RTO-TR-IST-075&s=Search All STO Reports>

- Baczynska, G., Macdonald, A., & Jones, G. (2016, December 7). EU urged to share data better to detect militants returning from Syria, Iraq. *Reuters*. Retrieved from <http://www.reuters.com/article/us-europe-attacks-eu-fighters-idUSKBN13W1RT>
- Bakalova, Z., Daneva, M., Herrmann, A., & Wieringa, R. (2011). Agile Requirements Prioritization: What Happens in Practice and What Is Described in Literature. In *Lecture Notes in Computer Science (including subseries Lecture Notes in Artificial Intelligence and Lecture Notes in Bioinformatics)* (Vol. 6606 LNCS, pp. 181–195). [https://doi.org/10.1007/978-3-642-19858-8\\_18](https://doi.org/10.1007/978-3-642-19858-8_18)
- Balanced Scorecard Institute. (2016). Balanced Scorecard Basics. Retrieved December 12, 2016, from <http://balancedscorecard.org>
- Bali, R. K., Wickramasinghe, N., & Lehane, B. (2009). *Knowledge Management Primer* (1st ed.). Routledge.
- Barnaghi, P., Compton, M., Corcho, O., Castro, R. G., Graybeal, J., Herzog, A., ... Page, K. (2011). *Semantic Sensor Network XG Final Report*. Retrieved from <https://www.w3.org/2005/Incubator/ssn/XGR-ssn-20110628/>
- Baseline. (2006). Post-9/11, a New Push for Information Sharing. *Baseline Magazine*, 67–73.
- Baskerville, R., Pries-Heje, J., & Venable, J. (2009). Soft design science methodology. In *Proceedings of the 4th International Conference on Design Science Research in Information Systems and Technology - DESRIST '09* (p. 1). New York, New York, USA: ACM Press. <https://doi.org/10.1145/1555619.1555631>
- Bassi, A., Bauer, M., Fiedler, M., Kramp, T., Kranenburg, R. Van, Lange, S., & Meissner, S. (n.d.). Enabling Things to Talk Designing IoT solutions with the IoT Architectural Reference Model. Retrieved from <https://link.springer.com/content/pdf/10.1007/978-3-642-40403-0.pdf>
- Batini, C., Lenzerini, M., & Navathe, S. B. (1986). A comparative analysis of methodologies for database schema integration. *ACM Computing Surveys*, 18(4), 323–364. <https://doi.org/10.1145/27633.27634>
- Batty, M., Axhausen, K. W., Giannotti, F., Pozdnoukhov, A., Bazzani, A., Wachowicz, M., ... Portugali, Y. (2012). Smart cities of the future. *The European Physical Journal Special Topics*, 214(1), 481–518. <https://doi.org/10.1140/epjst/e2012-01703-3>
- Baum, C., & Di Maio, A. (2000). *Gartner's Four Phases of E- Government Model*. Retrieved from <https://www.gartner.com/doc/317292/gartners-phases-egovernment-model>
- Bekkers, V. (2007). The governance of back-office integration. *Public Management Review*, 9(3), 377–



400. <https://doi.org/10.1080/14719030701425761>

- Bekkers, V. (2009). Flexible information infrastructures in Dutch e-Government collaboration arrangements: Experiences and policy implications. *Government Information Quarterly*, 26(1), 60–68.
- Bellahsene, Z., Bonifati, A., & Rahm, E. (Eds.). (2011). *Schema Matching and Mapping*. Berlin, Heidelberg: Springer Berlin Heidelberg. <https://doi.org/10.1007/978-3-642-16518-4>
- Bellamy, C. (2000). The Politics of Public Information Systems. In G. Garson (Ed.), *Handbook of Public Information Systems* (2nd ed., pp. 85–98). New York: Marcel Dekker.
- Ben Alaya, M., Medjiah, S., Monteil, T., & Drira, K. (2015). Towards Semantic Data Interoperability in oneM2M Standard. *IEEE Communications Magazine*, 53(12), 35–41.
- Berner, E. S. (2007). *Clinical Decision Support Systems: Theory and Practice*. (E. S. Berner, Ed.) (2nd ed.). New York: Springer.
- Bernstein, P. A. (1996). Middleware: a model for distributed system services. *Communications of the ACM*, 39(2), 86–98. <https://doi.org/10.1145/230798.230809>
- Biletskiy, Y., Ranganathan, G. R., & Vorochek, O. (2010). Identification and resolution of conflicts during ontological integration using rules. *Expert Systems*, 27(2), 75–89. <https://doi.org/10.1111/j.1468-0394.2010.00511.x>
- Bishr, Y. (1998). Overcoming the semantic and other barriers to GIS interoperability. *International Journal of Geographical Information Science*, 12(4), 299–314. <https://doi.org/10.1080/136588198241806>
- Bizer, C., Heath, T., & Berners-Lee, T. (2009). Linked Data - The Story So Far. *International Journal on Semantic Web and Information Systems*, 5(3), 1–22. <https://doi.org/10.4018/jswis.2009081901>
- Blackman, S. (2017). Towards a Conceptual Framework for Persistent Use: A Technical Plan to Achieve Semantic Interoperability within Electronic Health Record Systems. In *Proceedings of the 50th Hawaii International Conference on System Sciences*. <https://doi.org/10.24251/HICSS.2017.566>
- Bonacin, R., Nabuco, O. F., & Pierozzi, I. (2014). Modeling the Impacts of Agriculture on Water Resources: Semantic Interoperability Issues. In *2014 IEEE 23rd International WETICE Conference* (pp. 447–452). IEEE. <https://doi.org/10.1109/WETICE.2014.17>
- Bonacin, R., Nabuco, O. F., & Pierozzi Junior, I. (2016). Ontology models of the impacts of agriculture

- and climate changes on water resources: Scenarios on interoperability and information recovery. *Future Generation Computer Systems*, 54, 423–434. <https://doi.org/10.1016/j.future.2015.04.010>
- Bowles, K. H., Potashnik, S., Ratcliffe, S. J., Rosenberg, M., Shih, N.-W., Topaz, M., & Naylor, M. D. (2013). Conducting research using the electronic health record across multi-hospital systems: Semantic harmonization implications for administrators. *Journal of Nursing Administration*, 43(6), 355–360.
- Bradburn, N. M., Sudman, S., & Wansink, B. (2004). *Asking Questions: The Definitive Guide to Questionnaire Design For Market Research, Political Polls, and Social and Health Questionnaires*. (John Wiley & Sons, Ed.) (Revised). San Francisco: Jossey-Bass.
- Bronstein, H. (2016, December 23). Argentina, U.S. affirm ties with new tax information deal. *Reuters*. Retrieved from <http://www.reuters.com/article/us-argentina-usa-tax-idUSKBN14C1GZ>
- C. Fishburn, P. (1967). Additive Utilities with Incomplete Product Set: Applications to Priorities and Assignments. *Operations Research*, 15(3), 537–542.
- Caffrey, L. (2000). *Information Sharing Between & Within Governments*. (L. Caffrey, Ed.). London: Commonwealth Secretariat.
- Calo, K., Cenci, K., Fillottrani, P., & Estévez, E. (2012). Information Sharing. Benefits. *Journal of Computer Science & Technology*, 12(2), 49–55.
- Canestraro, D. S., Pardo, T. A., Raup-Kounovsky, A. N., & Taratus, D. (2009). Regional telecommunication incident coordination: Sharing information for rapid response. *Information Polity*, 14(1,2), 113–126. <https://doi.org/10.3233/IP-2009-0166>
- Cardoso de Moraes, J. L., de Souza, W. L., Pires, L. F., & do Prado, A. F. (2016). A methodology based on open EHR archetypes and software agents for developing e-health applications reusing legacy systems. *Computer Methods and Programs in Biomedicine*, 134, 267–287. <https://doi.org/10.1016/j.cmpb.2016.07.013>
- Cavalini, L. T., & Cook, T. W. (2014). Use of XML Schema Definition for the Development of Semantically Interoperable Healthcare Applications (pp. 125–145). Springer, Berlin, Heidelberg. [https://doi.org/10.1007/978-3-642-53956-5\\_9](https://doi.org/10.1007/978-3-642-53956-5_9)
- Chen, S. J., Hwang, C. L., & Hwang, F. P. (1992). Fuzzy multiple attribute decision making (methods and applications). *Lecture Notes in Economics and Mathematical Systems*.
- Choi, N., Song, I.-Y., & Han, H. (2006). A survey on ontology mapping. *ACM SIGMOD Record*, 35(3),

34–41. <https://doi.org/10.1145/1168092.1168097>

Council of the European Union. (2014). European Union Maritime Security Strategy. Brussels.

Creasey, J. C. (2013). Protecting Critical National Infrastructure Through Collaborative Cyber Situational Awareness. In *8th IET International System Safety Conference incorporating the Cyber Security Conference 2013* (Vol. 3, p. 3.2-3.2). Institution of Engineering and Technology. <https://doi.org/10.1049/cp.2013.1708>

Cresswell, A. M., Pardo, T. a., Canestraro, D. S., Dawes, S. S., & Juraga, D. (2005). *Sharing Justice Information: A Capability Assessment Toolkit*. Center for Technology in Government. Retrieved from [www.ctg.albany.edu/publications/guides/sharing\\_justice\\_info/sharing\\_justice\\_info.pdf](http://www.ctg.albany.edu/publications/guides/sharing_justice_info/sharing_justice_info.pdf)

Dahlan, A. R. A., Dahan, H. M., & Saman, M. Y. M. (2013). The government information sharing (GIS) in natural disaster management and risk reduction. In *2013 5th International Conference on Information and Communication Technology for the Muslim World (ICT4M)* (pp. 1–7). IEEE. <https://doi.org/10.1109/ICT4M.2013.6518927>

Davenport, D. T. H., & Prusak, L. (2000). *Working Knowledge: How Organizations Manage What They Know - Thomas H. Davenport, Laurence Prusak*. Boston, MA, USA: Harvard Business School Press.

Dawes, S. S. (1996). Interagency Information Sharing: Expected Benefits, Manageable Risks. *Journal of Policy Analysis and Management*, *15*(3), 377–394.

Dawes, S. S., Cresswell, A. M., & Pardo, T. A. (2009). From “Need to Know” to “Need to Share”: Tangled Problems, Information Boundaries, and the Building of Public Sector Knowledge Networks. *Public Administration Review*, *69*(3), 392–402. [https://doi.org/10.1111/j.1540-6210.2009.01987\\_2.x](https://doi.org/10.1111/j.1540-6210.2009.01987_2.x)

de Lusignan, S., Pearce, C., Shaw, N. T., Liaw, S.-T., Michalakidis, G., Vicente, M. T., ... Federation Primary Care Informatics Working Groups (PCI-WG). (2011). What are the barriers to conducting international research using routinely collected primary care data? *Studies in Health Technology and Informatics*, *165*, 135–140. Retrieved from <http://www.ncbi.nlm.nih.gov/pubmed/21685599>

den Hartog, F., Daniele, L., & Roes, J. (2015). Toward semantic interoperability of energy using and producing appliances in residential environments. In *2015 12th Annual IEEE Consumer Communications and Networking Conference (CCNC)* (pp. 170–175). IEEE. <https://doi.org/10.1109/CCNC.2015.7157972>

Dentler, K., ten Teije, A., Cornet, R., & de Keizer, N. (2013). Semantic Integration of Patient Data and

- Quality Indicators Based on openEHR Archetypes. In H. Springer, Berlin (Ed.), *Health Care. Lecture Notes in Computer Science, vol 7738* (pp. 85–97). Springer, Berlin, Heidelberg. [https://doi.org/10.1007/978-3-642-36438-9\\_6](https://doi.org/10.1007/978-3-642-36438-9_6)
- Desai, P., Sheth, A., & Anantharam, P. (2015). Semantic Gateway as a Service Architecture for IoT Interoperability. In *2015 IEEE International Conference on Mobile Services* (pp. 313–319). IEEE. <https://doi.org/10.1109/MobServ.2015.51>
- Ding, W. (2013). Study of Smart Warehouse Management System Based on the IOT. In *Intelligence Computation and Evolutionary Computation* (pp. 203–207). [https://doi.org/10.1007/978-3-642-31656-2\\_30](https://doi.org/10.1007/978-3-642-31656-2_30)
- Dixon, B. E., Simonaitis, L., Goldberg, H. S., Paterno, M. D., Schaeffer, M., & Hongsermeier, T. (2013). A pilot study of distributed knowledge management and clinical decision support in the cloud. *Artif. Intell. Med.*, (59). <https://doi.org/http://dx.doi.org/10.1016/j.artmed.2013.03.004>
- Doan, A., & Halevy, A. (2005). Semantic Integration Research in the Database Community: A Brief Survey. *AI Magazine*, 26(1), 83–94. <https://doi.org/10.1609/aimag.v26i1.1801>
- Dolin, R. H., Alschuler, L. (2011). Approaching semantic interoperability in Health Level Seven. *Journal of the American Medical Informatics Association*, 18(1). <https://doi.org/http://dx.doi.org/10.1136/jamia.2010.007864>
- Dresch, A., P. Lacerda, D., & A. V. Antunes Jr, J. (2015). *Design Science Research. A Method for Science and Technology Advancement*. (Springer, Ed.). Springer.
- Eisenhammer, S., & Brown Tom. (2016, April 15). Brazil sees rising threat from Islamic militants: intelligence agency. *Reuters*. Retrieved from <http://www.reuters.com/article/us-brazil-security-idUSKCN0XC01G>
- et al. Hevner, A. R., & Hevner, A. R. et al. (2004). Design Science in Information Systems Research. *MIS Quarterly*, 28(1), 75–105.
- European Commission. (2004). *European Interoperability Framework for pan-European eGovernment Services* (Vol. version 1). Luxembourg. <https://doi.org/10.1109/HICSS.2007.68>
- European Commission. (2007). An Integrated Maritime Policy for the European Union. COM(2007) 575 final. Brussels, Belgium.
- European Commission. (2010a). A Digital Agenda for Europe. COM(2010) 245 final. Brussels, Belgium.
- European Commission. (2010b). EUROPE 2020. A European strategy for smart, sustainable and inclusive

growth. COM(2010) 2020. Brussels.

European Commission. (2010c). European Interoperability Framework for European Public Services. Annex 2 to COM(2010) 744 final.

European Commission. (2010d). *European Interoperability Strategy (EIS) for European public services. Annex 1 to COM(2010) 744 final*. Brussels, Belgium. Retrieved from [http://ec.europa.eu/isa/documents/isa\\_annex\\_i\\_eis\\_en.pdf](http://ec.europa.eu/isa/documents/isa_annex_i_eis_en.pdf)

European Commission. (2010e). Integrating Maritime Surveillance. Common Information Sharing Environment (CISE). COM(2010) 584 final. Brussels. <https://doi.org/10.2771/64104>

European Commission. (2010f). Towards interoperability for European public services. COM(2010) 744 final. Brussels, Belgium.

European Commission. (2012). eHealth Action Plan 2012-2020 - Innovative Healthcare for the 21st century. COM(2012) 736 final. Brussels, Belgium.

European Commission. (2014a). CISE Roadmap. Brussels, Belgium.

European Commission. (2014b). Executive Summary of the (CISE) Impact Assessment. SWD(2014) 224 final. Brussels.

European Commission. (2015a). A Digital Single Market Strategy for Europe. COM(2015) 192 final. Brussels, Belgium.

European Commission. (2015b). A European Agenda on Migration. COM(2015) 240 final. Brussels, Belgium.

European Commission. (2015c). The European Agenda on Security. COM(2015) 185 final. Strasbourg.

European Commission. (2016). *Interoperability Maturity Model Guideline*. Brussels. Retrieved from [https://joinup.ec.europa.eu/sites/default/files/document/2016-03/imm\\_guideline\\_1.pdf](https://joinup.ec.europa.eu/sites/default/files/document/2016-03/imm_guideline_1.pdf)

European Commission. European Interoperability Framework - Implementation Strategy. COM(2017) 134 final. Annex 1, Pub. L. No. COM(2017) 134 final, 4 (2017). Retrieved from [http://eur-lex.europa.eu/resource.html?uri=cellar:2c2f2554-0faf-11e7-8a35-01aa75ed71a1.0017.02/DOC\\_2&format=PDF](http://eur-lex.europa.eu/resource.html?uri=cellar:2c2f2554-0faf-11e7-8a35-01aa75ed71a1.0017.02/DOC_2&format=PDF)

European Commission. (2017b). European Interoperability Framework - Implementation Strategy. COM(2017) 134 final.

- European Commission. (2017c). Implementation of the Common Information Sharing Environment (CISE) for the EU maritime domain: Ensuring interoperability of National IT Systems to allow for more efficient information exchange within and across borders. Retrieved October 31, 2017, from <https://ec.europa.eu/easme/en/implementation-common-information-sharing-environment-cise-eu-maritime-domain-ensuring>
- European Commission. (2018). CEF Telecom Projects. Retrieved April 9, 2018, from <https://ec.europa.eu/inea/en/connecting-europe-facility/cef-telecom/cef-telecom-projects>
- European Parliament, & Council of Europe. (2011). Directive 2011/24/EU on the application of patients' rights in cross-border healthcare.
- European Parliament, & Council of the European Union. (2016). Regulation 5419/16 on the protection of natural persons with regard to the processing of personal data and on the free movement of such data. *Official Journal of the European Communities*.
- EUROPOL. (2017). *European Union Terrorism Situation and Trend Report 2017*. <https://doi.org/10.2813/237471>
- Euzenat, J., Roşoiu, M.-E., & Trojahn, C. (2013). Ontology matching benchmarks: Generation, stability, and discriminability. *Web Semantics: Science, Services and Agents on the World Wide Web*, 21, 30–48. <https://doi.org/10.1016/j.websem.2013.05.002>
- Euzenat, J., & Shvaiko, P. (2013). *Ontology Matching*. Berlin, Heidelberg: Springer Berlin Heidelberg. <https://doi.org/10.1007/978-3-642-38721-0>
- Euzenat, J., & Valtchev, P. (2004). Similarity-based ontology alignment in OWL-Lite. In R. Mántaras & L. Saitta (Eds.), *ECAI2004: 16th European Conference on Artificial Intelligence* (pp. 333–337). Valencia, Spain: IOS Press.
- Feng, C.-C., & Flewelling, D. M. M. (2004). Assessment of semantic similarity between land use/land cover classification systems. *Computers, Environment and Urban Systems*, 28(3), 229–246. [https://doi.org/10.1016/S0198-9715\(03\)00020-6](https://doi.org/10.1016/S0198-9715(03)00020-6)
- Fernández-Breis, J. T., Maldonado, J. A., Marcos, M., Legaz-García, M. del C., Moner, D., Torres-Sospedra, J., ... Robles, M. (2013). Leveraging electronic healthcare record standards and semantic web technologies for the identification of patient cohorts. *Journal of the American Medical Informatics Association*, 20(e2), e288–e296. <https://doi.org/10.1136/amiajnl-2013-001923>
- Finnish Border Guard. (2014). *Test Project on Cooperation in Execution of Various Maritime Functionalities at Sub-Regional or Sea-Basin Level in the Field of Integrated Maritime Surveillance*

- (CoopP). *Final Report*. Helsinki. Retrieved from <https://www.google.it/url?sa=t&rct=j&q=&esrc=s&source=web&cd=1&cad=rja&uact=8&ved=0ahUKEwi30YSqt8DVAhWT0RoKHdqTDaoQFggqMAA&url=http%3A%2F%2Fwww.statewatch.org%2Fnews%2F2014%2Fjul%2Feu-2014-coop-project-final-report.pdf&usq=AFQjCNGMPGmyqpIwpBS4YISmHWQu8cXv>
- Flahive, A., & Jakobsson, Å. (2008). Semantic Interoperability: Necessary for Net-Centric Platform Integration. In *Systems Engineering, Test and Evaluation Conference*. Canberra: Defence Science and Technology Organisation.
- Ford, R., Hansen, B. J., Hanz, D., Kuehne, S., Last, M., Mojtahedzadeh, V., ... Wunder, M. (2015). Bridging Semantic Interoperability gaps with SILF. In *2015 International Conference on Military Communications and Information Systems (ICMCIS)* (pp. 1–11). IEEE. <https://doi.org/10.1109/ICMCIS.2015.7158678>
- Franceschini, F., Galetto, M., & Maisano, D. (2007). *Management by Measurement. Designing Key Indicators and Performance Measurement Systems*. Springer.
- Fürst, F., & Trichet, F. (2009). Axiom-based ontology matching. *Expert Systems*, 26(2), 218–246.
- Gal, A., & Shvaiko, P. (2009). Advances in Ontology Matching. In T. S. Dillon, E. Chang, R. Meersman, & K. Sycara (Eds.), *Advances in Web Semantics I* (pp. 176–198). Springer.
- Gamble, P. R., & Blackwell, J. (2001). *Knowledge Management: A State of the Art Guide* (1st ed.). Kogan Page.
- Ganguly, P., Ray, P., & Parameswaran, N. (2005). Semantic Interoperability in Telemedicine through Ontology-Driven Services. *Telemedicine and E-Health*, 11(3), 405–412. <https://doi.org/10.1089/tmj.2005.11.405>
- Ganzha, M., Paprzycki, M., Pawłowski, W., Szmaja, P., & Wasielewska, K. (2017). Semantic interoperability in the Internet of Things: An overview from the INTER-IoT perspective. *Journal of Network and Computer Applications*, 81, 111–124. <https://doi.org/10.1016/j.jnca.2016.08.007>
- Garde, S., Knaup, P., Hovenga, E. J. S., & Heard, S. (2007). Towards Semantic Interoperability for Electronic Health Records. *Methods of Information in Medicine*, 46(03), 332–343. <https://doi.org/10.1160/ME5001>
- Gil-Garcia, J. R., Schneider, C. A., Pardo, T. A., & Cresswell, A. M. (2005). Interorganizational Information Integration in the Criminal Justice Enterprise: Preliminary Lessons from State and County Initiatives. In *Proceedings of the 38th Annual Hawaii International Conference on System*

*Sciences* (p. 118c–118c). IEEE. <https://doi.org/10.1109/HICSS.2005.338>

Gil-Garcia, J. R., Soon Ae, C., & Janssen, M. (2009). Government information sharing and integration: Combining the social and the technical. *Information Polity: The International Journal of Government & Democracy in the Information Age*, 14(1/2), 1–10.

Gil, R., & Martin-Bautista, M. J. (2014). SMOL: a systemic methodology for ontology learning from heterogeneous sources. *Journal of Intelligent Information Systems*, 42(3), 415–455. <https://doi.org/10.1007/s10844-013-0296-x>

Giunchiglia, F., Maltese, V., & Autayeu, A. (2012). Computing minimal mappings between lightweight ontologies. *International Journal on Digital Libraries*, 12(4), 179–193. <https://doi.org/10.1007/s00799-012-0083-2>

Gordon, L. A., Loeb, M. P., & Lucyshyn, W. (2003). Sharing information on computer systems security: An economic analysis. *Journal of Accounting and Public Policy*, 22(6), 461–485. <https://doi.org/10.1016/j.jaccpubpol.2003.09.001>

Gordon, L., Loeb, M. M., & Lucyshyn, W. (2002). An Economics Perspective on the Sharing of Information Related to Security Breaches: Concepts and Empirical Evidence. In *Workshop on Economics and Information Security*. Berkeley, California, USA: University of California. Retrieved from [http://www.cpppe.umd.edu/Bookstore/Documents/Economic Incentives\\_05.17.02.pdf](http://www.cpppe.umd.edu/Bookstore/Documents/Economic_Incentives_05.17.02.pdf)

Gruber, T. R. (1993). A translation approach to portable ontology specifications. *Knowledge Acquisition*, 5(2), 199–220. <https://doi.org/10.1006/knac.1993.1008>

Guédria, W., Chen, D., & Naudet, Y. (2009). A Maturity Model for Enterprise Interoperability. In *Lecture Notes in Computer Science* (Vol. 5872, pp. 216–225). [https://doi.org/10.1007/978-3-642-05290-3\\_32](https://doi.org/10.1007/978-3-642-05290-3_32)

Guédria, W., Naudet, Y., & Chen, D. (2008). Interoperability Maturity Models – Survey and Comparison. In *Lecture Notes in Computer Science* (Vol. 5333, pp. 273–282). [https://doi.org/10.1007/978-3-540-88875-8\\_48](https://doi.org/10.1007/978-3-540-88875-8_48)

Heflin, J., & Song, D. (2016). Ontology instance linking: towards interlinked knowledge graphs. In *Proceedings of the Thirtieth AAAI Conference on Artificial Intelligence (AAAI-16)* (pp. 4163–4169). AAAI Press. Retrieved from <https://dl.acm.org/citation.cfm?id=3016507>

Heidenberg, J., Weijola, M., Mikkonen, K., & Porres, I. (2012). A Model for Business Value in Large-Scale Agile and Lean Software Development. In *Systems, Software and Services Process Improvement* (pp. 49–60). [https://doi.org/10.1007/978-3-642-31199-4\\_5](https://doi.org/10.1007/978-3-642-31199-4_5)



- Heiler, S. (1995). Semantic interoperability. *ACM Computing Surveys*, 27(2), 271–273. <https://doi.org/10.1145/210376.210392>
- Herzog, A., & Buchmann, A. (2012). A3ME - generic middleware for information exchange in heterogeneous environments. In *2012 Ninth International Conference on Networked Sensing (INSS)* (pp. 1–4). IEEE. <https://doi.org/10.1109/INSS.2012.6240554>
- Hevner, A., & Chatterjee, S. (2010). Design research in information systems: theory and practice. *Springer Science & Business Media*, 22. Retrieved from [https://www.google.it/url?sa=t&rct=j&q=&esrc=s&source=web&cd=3&cad=rja&uact=8&ved=0ahUKEwjLv\\_bWiqfVAhWIRhQKHerhASEQFghDMAI&url=http%3A%2F%2Fwww.springer.com%2Fcda%2Fcontent%2Fdocument%2Fcda\\_downloaddocument%2F9781441956521-c1.pdf%3FSGWID%3D0-0-45-929646-p](https://www.google.it/url?sa=t&rct=j&q=&esrc=s&source=web&cd=3&cad=rja&uact=8&ved=0ahUKEwjLv_bWiqfVAhWIRhQKHerhASEQFghDMAI&url=http%3A%2F%2Fwww.springer.com%2Fcda%2Fcontent%2Fdocument%2Fcda_downloaddocument%2F9781441956521-c1.pdf%3FSGWID%3D0-0-45-929646-p)
- HL7. (1987). Health Level Seven International. Retrieved from <http://hl7.org/>
- Hourelid, K. (2017, March 14). Somali pirates hijack first commercial ship since 2012 | Reuters. *Reuters*. Retrieved from <http://www.reuters.com/article/us-somalia-hijack-idUSKBN16L0EW>
- Hu, W., Qu, Y., & Cheng, G. (2008). Matching large ontologies: A divide-and-conquer approach. *Data & Knowledge Engineering*, 67(1), 140–160.
- Hufnagel, S. P. (2009). National Electronic Health Record Interoperability Chronology. *Military Medicine*, 174(5S), 35–42. <https://doi.org/10.7205/MILMED-D-03-9708>
- Hwang, F. (1987). *An Expert Decision Making Support System for Multiple Attribute Decision Making*. Kansas State University, Manhattan, KS, USA.
- IEEE Computer Society. (1990). *Standard Computer Dictionary*. New York, USA: IEEE Computer Society. Retrieved from <http://elib.peaceland.edu.ng:8383/greenstone3/sites/localsite/collect/peacelan/index/assoc/HASHbaad/2439e09f.dir/doc.pdf>
- IHE. (2016). Integrating the Healthcare Enterprise. Retrieved from <http://ihe.net/>
- Information Sharing Environment Program Manager. (2006). *Information Sharing Environment Implementation Plan*. Washington, United States of America. Retrieved from [https://www.ise.gov/sites/default/files/ise-impplan-200611\\_0.pdf](https://www.ise.gov/sites/default/files/ise-impplan-200611_0.pdf)
- Information Sharing Environment Program Manager. (2015). *Information Sharing Environment: Annual Report to the Congress* (Vol. 1). Washington, United States of America. Retrieved from

[https://www.dni.gov/files/ISE/documents/AnnualReport/2015\\_ISE\\_Annual\\_Report.pdf](https://www.dni.gov/files/ISE/documents/AnnualReport/2015_ISE_Annual_Report.pdf)

IoT European Research Cluster. (2014). Open Platforms – IoT-A Architectural Reference Model. Retrieved April 15, 2018, from [http://open-platforms.eu/standard\\_protocol/iot-a-architectural-reference-model/](http://open-platforms.eu/standard_protocol/iot-a-architectural-reference-model/)

ISO. (2000). ISO 9000:2000, Quality Management Systems - Fundamentals and Vocabulary. Geneva.

ISO13606 community. (2008). The CEN/ISO 13606 Association site. Retrieved April 4, 2017, from <http://www.en13606.org/>

Italian Space agency. (2017). *CISE information model*.

Italian Space Agency. (2015). EUCISE2020. Retrieved from <http://www.eucise2020.eu/>

Janowicz, K., Keßler, C., Schwarz, M., Wilkes, M., Panov, I., Espeter, M., & Bäumer, B. (2007). Algorithm, Implementation and Application of the SIM-DL Similarity Server. In *GeoSpatial Semantics* (pp. 128–145). Berlin, Heidelberg: Springer Berlin Heidelberg. [https://doi.org/10.1007/978-3-540-76876-0\\_9](https://doi.org/10.1007/978-3-540-76876-0_9)

Jean-Mary, Y. R., Shironoshita, E. P., & Kabuka, M. R. (2009). Ontology matching with semantic verification. *Web Semantics: Science, Services and Agents on the World Wide Web*, 7(3), 235–251. <https://doi.org/10.1016/j.websem.2009.04.001>

Jing, F., & Pengzhu, Z. (2009). A Field Study of G2G Information Sharing in Chinese Context Based on the Layered Behavioral Model. In *2009 42nd Hawaii International Conference on System Sciences* (pp. 1–13). IEEE. <https://doi.org/10.1109/HICSS.2009.12>

Juanzi Li, Jie Tang, Yi Li, & Qiong Luo. (2009). RiMOM: A Dynamic Multistrategy Ontology Alignment Framework. *IEEE Transactions on Knowledge and Data Engineering*, 21(8), 1218–1232. <https://doi.org/10.1109/TKDE.2008.202>

K. Jaroensutasinee, M. Jaroensutasinee, S. Bainbridge, T. Fountain, S. Holbrook, M. N. (2012). CREON—integrating disparate sources of remote coral reef sensor data. In *Proceedings of the 12th International Coral Reef Symposium*.

KALFOGLOU, Y., & SCHORLEMMER, M. (2003). Ontology mapping: the state of the art. *The Knowledge Engineering Review*, 18(1), S0269888903000651. <https://doi.org/10.1017/S0269888903000651>

Kalra, D., & Blobel, B. G. M. E. (2007). Semantic interoperability of EHR systems. *Studies in Health Technology and Informatics*, 127, 231–245. Retrieved from

<http://www.ncbi.nlm.nih.gov/pubmed/17901615>

- Kaplan, B., & Harris-Salamone, K. D. (2009). Health IT Success and Failure: Recommendations from Literature and an AMIA Workshop. *Journal of the American Medical Informatics Association*, 16(3), 291–299. <https://doi.org/10.1197/jamia.M2997>
- Kaplan, R., & Norton, D. (1996). Using the Balanced Scorecard as a Strategic Management System. *Harvard Business Review*, 74(1), 75–85.
- Kashfi, H., & Torgersson, O. (2009). A migration to an openEHR-based clinical application. *Studies in Health Technology and Informatics*, 150, 152–156.
- Kashyap, V., & Sheth, A. P. (1996). Semantic heterogeneity in global information system: The role of metadata, context, and ontologies. *Cooperative Information Systems: Current Trends and Directions*, 139–178.
- Kawamoto, K., Hongsermeier, T., Wright, A., Lewis, J., Bell, D. S., & Middleton, B. (2013). Key principles for a national clinical decision support knowledge sharing framework: synthesis of insights from leading subject matter experts. *Journal of the American Medical Informatics Association*, 20(1), 199–207. <https://doi.org/10.1136/amiajnl-2012-000887>
- Kean, T. H., & Hamilton, L. H. (2004). *The 9/11 Commission Report: Final Report of the National Commission on Terrorist Attacks Upon the United States*. Retrieved from <https://www.9-11commission.gov/report/911Report.pdf>
- Khan, W. A., Khattak, A. M., Hussain, M., Amin, M. B., Afzal, M., Nugent, C., & Lee, S. (2014). An adaptive semantic based mediation system for data interoperability among Health Information Systems. *Journal of Medical Systems*, 38(8), 28.
- Khan, W. A., Khattak, A. M., Hussain, M., Amin, M. B., Afzal, M., Nugent, C., & Lee, S. (2014). An Adaptive Semantic based Mediation System for Data Interoperability among Health Information Systems. *Journal of Medical Systems*, 38(8), 28. <https://doi.org/10.1007/s10916-014-0028-y>
- Kiljander, J., D'elia, A., Morandi, F., Hyttinen, P., Takalo-Mattila, J., Ylisaukko-Oja, A., ... Cinotti, T. S. (2014). Semantic Interoperability Architecture for Pervasive Computing and Internet of Things. *IEEE Access*, 2, 856–873. <https://doi.org/10.1109/ACCESS.2014.2347992>
- Kiljander, J., D'elia, A., Morandi, F., Hyttinen, P., Takalo-Mattila, J., Ylisaukko-Oja, A., ... Cinotti, T. S. (2014). Semantic Interoperability Architecture for Pervasive Computing and Internet of Things. *IEEE Access*, 2, 856–873. <https://doi.org/10.1109/ACCESS.2014.2347992>

- Klein, M., & Fensel, D. (2001). Ontology versioning on the semantic web. In *Proceedings of the First International Conference on Semantic Web Working (SWWS'01)* (pp. 75–91).
- Knaup, P., Bott, O., Kohl, C., Lovis, C., & Garde, S. (2007). Electronic Patient Records: Moving from Islands and Bridges towards Electronic Health Records for Continuity of Care. *IMIA Yearbook*, 34–46. Retrieved from <http://www.schattauer.de/t3page/1214.html?manuscript=8403&L=1>
- Koster, M. (2014). Information Models for an Interoperable Web of Things (Position paper). In *W3C Workshop on the Web of Things - Enablers and Services for an open Web of Devices*. Berlin.
- Kovacs, E., Bauer, M., Kim, J., Yun, J., Le Gall, F., & Zhao, M. (2016). Standards-Based Worldwide Semantic Interoperability for IoT. *IEEE Communications Magazine - Communications Standards Supplement*, (December), 40–46.
- Kuan, K., & Chau, P. (2001). A perception-based model for EDI adoption in small businesses using a technology–organization–environment framework. *Information & Management*, 38(8), 507–521. [https://doi.org/10.1016/S0378-7206\(01\)00073-8](https://doi.org/10.1016/S0378-7206(01)00073-8)
- Kumar, S. K., & Harding, J. A. (2013). Ontology mapping using description logic and bridging axioms. *Computers in Industry*, 64(1), 19–28. <https://doi.org/10.1016/j.compind.2012.09.004>
- Laclavík, M., Šeleng, M., Ciglan, M., & Hluchý, L. (2009). Ontea: Platform for Pattern Based Automated Semantic Annotation. *Computing and Informatics*, 28(4), 555–579.
- Landsbergen Jr., D., & Wolken Jr., G. (2005). Realizing the promise: Government Information Systems and the Fourth Generation of Information Technology. *Public Administration Review*, 61(2), 206–220.
- Lasi, H., Fettke, P., Kemper, H. G. (2014). Industry 4.0. *Business & Information Systems Engineering*, 6(4), 239–242. <https://doi.org/https://doi.org/10.1007/s12599-014-0334-4>
- le Vrang, M., Papantoniou, A., Pauwels, E., Fannes, P., Vandenstein, D., & De Smedt, J. (2014). ESCO: Boosting Job Matching in Europe with Semantic Interoperability. *IEEE Computer*, 47(10), 57–64. <https://doi.org/10.1109/MC.2014.283>
- Lee, J., & Rao, H. R. (2007). Exploring the causes and effects of inter-agency information sharing systems adoption in the anti/counter-terrorism and disaster management domains. In *8th Annual International Conference on Digital Government Research* (Vol. 228, pp. 155–163). Digital Government Society of North America.
- Lewis, G. A., Morris, E., Simanta, S., & Wrage, L. (2008). Why Standards Are Not Enough to Guarantee

- End-to-End Interoperability. In *Seventh International Conference on Composition-Based Software Systems (ICCBSS 2008)* (pp. 164–173). IEEE. <https://doi.org/10.1109/ICCBSS.2008.25>
- Liao, Y., Lezoche, M., Loures, E. R., Panetto, H., & Boudjlida, N. (2014). A Semantic Annotation Framework to Assist the Knowledge Interoperability along a Product Life Cycle. *Advanced Materials Research*, 945–949, 424–429. <https://doi.org/10.4028/www.scientific.net/AMR.945-949.424>
- Linstone, Harold A. Turoff, M. (1975). *The Delphi Method: Techniques and Applications*. (Addison-Wesley, Ed.). Reading, MA: Addison-Wesley.
- Liow, J. C. (2016). The escalating ISIS threat in Southeast Asia - CNN.com. *CNN*. Retrieved from <http://edition.cnn.com/2016/07/07/opinions/isis-southeast-asia-liow/>
- Liu, Q., Huang, T., Liu, S.-H., & Zhong, H. (2007). An Ontology-Based Approach for Semantic Conflict Resolution in Database Integration. *Journal of Computer Science and Technology*, 22(2), 218–227. <https://doi.org/10.1007/s11390-007-9028-4>
- Luna-Reyes, L. F., Gil-Garcia, J. R., & Cruz, C. B. (2007). Collaborative digital government in Mexico: Some lessons from federal web-based interorganizational information integration initiatives. *Government Information Quarterly*, 24(4), 808–826.
- Luz, M. P., Nogueira, J. R. de M., Cavalini, L. T., & Cook, T. W. (2015). Providing Full Semantic Interoperability for the Fast Healthcare Interoperability Resources Schemas with Resource Description Framework. In *2015 International Conference on Healthcare Informatics* (pp. 463–466). IEEE. <https://doi.org/10.1109/ICHI.2015.74>
- M, Laclavík, M., Dlugolinský, Š., Šeleng, M., Ciglan, M., Tomašek, M., Kvassay, M., & Hluchý, L. (2012). Lightweight semantic approach for enterprise search and interoperability. In *CEUR Workshop Proceedings: INVIT 2012* (pp. 35–42).
- Ma, X., Zheng, J. G., Goldstein, J., Zednik, S., Fu, L., Duggan, B., ... Fox, P. (2014). Ontology engineering in provenance enablement for the National Climate Assessment. *Environ. Model. Softw.*, 61, 191–205.
- Macia, I. (2014). Towards a semantic interoperability environment. In *2014 IEEE 16th International Conference on e-Health Networking, Applications and Services (Healthcom)* (pp. 543–548). IEEE. <https://doi.org/10.1109/HealthCom.2014.7001900>
- March, & Storey. (2008). Design Science in the Information Systems Discipline: An Introduction to the Special Issue on Design Science Research. *MIS Quarterly*, 32(4), 725.

<https://doi.org/10.2307/25148869>

- Marco-Ruiz, L., Pedrinaci, C., Maldonado, J. A. A., Panziera, L., Chen, R., & Bellika, J. G. (2016). Publication, discovery and interoperability of Clinical Decision Support Systems: A Linked Data approach. *Journal of Biomedical Informatics*, *62*, 243–264. <https://doi.org/10.1016/j.jbi.2016.07.011>
- Martínez-Costa, C., Kalra, D., & Schulz, S. (2014). Improving EHR semantic interoperability: future vision and challenges. *Studies in Health Technology and Informatics*, *205*, 589–593.
- McMillan, E. (2008). *Complexity, Management and the Dynamics of Change: Challenges for Practice* (1st ed.). Routledge.
- Meiner, A. (2010). Integrated maritime policy for the European Union — consolidating coastal and marine information to support maritime spatial planning. *Journal of Coastal Conservation*, *14*(1), 1–11. <https://doi.org/10.1007/s11852-009-0077-4>
- Menárguez-Tortosa, M., & Fernández-Breis, J. T. (2011). Validation of the openEHR archetype library by using OWL reasoning. *Studies in Health Technology and Informatics*, *169*, 789–793. Retrieved from <http://www.ncbi.nlm.nih.gov/pubmed/21893855>
- Mergel, I. (2016). Agile innovation management in government: A research agenda. *Government Information Quarterly*, *33*(3), 516–523. <https://doi.org/10.1016/j.giq.2016.07.004>
- MindTools. (2018). Developing Your Strategy. Retrieved April 12, 2018, from <https://www.mindtools.com/pages/article/developing-strategy.htm>
- Moon, M. J. (2002). The Evolution of E-Government among Municipalities: Rhetoric or Reality? *Public Administration Review*, *62*(4), 424–433. <https://doi.org/10.1111/0033-3352.00196>
- Moreno-Conde, A., Moner, D., Cruz, W. D. da, Santos, M. R., Maldonado, J. A., Robles, M., & Kalra, D. (2015). Clinical information modeling processes for semantic interoperability of electronic health records: systematic review and inductive analysis. *Journal of the American Medical Informatics Association*, *22*(4), 925–934. <https://doi.org/10.1093/jamia/ocv008>
- Morris, E., Levine, L., Meyers, C., Place, P., & Plakosh, D. (2004). *System of Systems Interoperability (SOSI): Final Report. Technical Report, CMU/SEI-2004-TR-004*. CMU/SEI. Retrieved from <http://www.sei.cmu.edu/pub/documents/04.reports/pdf/04tr004.pdf>
- NATO Multilateral Interoperability Programme. (2016). *The Joint C3 Information Exchange Data Model (JC3IEDM)*. Retrieved from <https://public.mip-interop.org>
- Neiva, F. W., David, J. M. N., Maciel, R. S. P., Braga, R., & Campos, F. (2014). SISS: Extending

- Semantic Interoperability to Support Collaborative System Development and Execution. In *Proceedings of the 2014 IEEE 18th International Conference on Computer Supported Cooperative Work in Design (CSCWD)* (pp. 53–58). IEEE. <https://doi.org/10.1109/CSCWD.2014.6846816>
- Nogueira, J. R. de M., Ahiazdro, N. C. L. de O., Cavalini, L. T., & Cook, T. W. (2015). Knowledge Management of Controlled Vocabularies for Semantic Interoperability of Healthcare Applications. In *2015 International Conference on Healthcare Informatics* (pp. 455–458). IEEE. <https://doi.org/10.1109/ICHI.2015.72>
- Nosofsky, R. M. (1992). Similarity Scaling and Cognitive Process Models. *Annual Review of Psychology*, 43(1), 25–53. <https://doi.org/10.1146/annurev.ps.43.020192.000325>
- Noy, N. F. (2004). Semantic integration: a survey of ontology-based approaches. *ACM SIGMOD Record*, 33(4), 65. <https://doi.org/10.1145/1041410.1041421>
- Noy, N. F. (2009). Ontology mapping. In R. Staab, S., Studer (Ed.), *Handbook on Ontologies* (pp. 573–590). Springer.
- Oates, B. J. (2006). *Researching Information Systems and Computing* (1st ed.). SAGE Publications.
- Object Management Group. (2015). *OMG Unified Modeling Language TM (OMG UML), Superstructure v.2.3*. InformatikSpektrum. <https://doi.org/10.1007/s002870050092>
- OECD. (2003). *The e-Government Imperative*. Paris, France: OECD Publishing. <https://doi.org/10.1787/9789264101197-en>
- Office of the Director of National Intelligence. (2015). *Brief History of the Information Sharing Environment (ISE)*. Retrieved from <https://www.dni.gov/files/ISE/documents/DocumentLibrary/Brief-History-ISE-2015.pdf>
- Ogunyemi, O. I., Meeker, D., Kim, H.-E., Ashish, N., Farzaneh, S., & Boxwala, A. (2013). Identifying appropriate reference data models for comparative effectiveness research (CER) studies based on data from clinical information systems. *Medical Care*, 51(8), 45–52.
- OIG. (2017). *Review of Domestic Sharing of Counterterrorism Information*. Retrieved from <https://oig.justice.gov/reports/2017/a1721.pdf#page=3>
- Open Geospatial Consortium. (2012). WaterML 2.0: Part 1 - Time series. Retrieved from [https://portal.opengeospatial.org/files/?artifact\\_id=48531](https://portal.opengeospatial.org/files/?artifact_id=48531)
- OpenEHR. (1998). Open Health Records. Retrieved from <http://openehr.org/>

- Organisation for Economic Co-operation and Development. (2010). *Glossary of Key Terms in Evaluation and Results Based Management*. Retrieved from <http://www.oecd.org/development/peer-reviews/2754804.pdf>
- Otero-Cerdeira, L., Rodríguez-Martínez, F. J., & Gómez-Rodríguez, A. (2015). Ontology matching: A literature review. *Expert Systems with Applications*, 42(2), 949–971. <https://doi.org/10.1016/J.ESWA.2014.08.032>
- Panetto, H., Dassisti, M., & Tursi, A. (2012). ONTO-PDM: Product-driven ONTOlogy for Product Data Management interoperability within manufacturing process environment. *Advanced Engineering Informatics*, 26(2), 334–348.
- Pardo, T. A., Cresswell, A. M., Dawes, S. S., & Burke, G. B. (2004). Modeling the social & technical processes of interorganizational information integration. In *37th Annual Hawaii International Conference on System Sciences, 2004. Proceedings of the* (p. 8 pp.). IEEE. <https://doi.org/10.1109/HICSS.2004.1265307>
- Pardo, T. A., & Tayi, G. K. (2007). Interorganizational information integration: A key enabler for digital government. *Government Information Quarterly*, 24(4), 691–715.
- Patel, V. L., & Shortliffe, E. H. (2014). Human-Intensive Techniques. In R. A. Greenes (Ed.), *Clinical Decision Support* (2nd ed., pp. 285–308). Oxford: Elsevier. <https://doi.org/10.1016/B978-0-12-398476-0.00010-5>
- Patil, L., Dutta, D., & Sriram, R. (2005). Ontology-Based Exchange of Product Data Semantics. *IEEE Transactions on Automation Science and Engineering*, 2(3), 213–225. <https://doi.org/10.1109/TASE.2005.849087>
- Patni, H., Henson, C., & Sheth, A. (2010). Linked sensor data. In *2010 International Symposium on Collaborative Technologies and Systems* (pp. 362–370). IEEE. <https://doi.org/10.1109/CTS.2010.5478492>
- Patton, E. W., Seyed, P., Wang, P., Fu, L., Dein, F. J., Bristol, R. S., & McGuinness, D. L. (2014). SemantEco: a semantically powered modular architecture for integrating distributed environmental and ecological data. *Future Gener. Comput. Systems*, 36, 430–444.
- Paul, M., & Ghosh, S. K. (2008). A framework for semantic interoperability for distributed geospatial repositories. *Computing and Informatics*, 27(1), 73–92.
- Pedrinaci, C., & Domingue, J. (2010). Toward the Next Wave of Services: Linked Services for the Web of Data. *Journal of Universal Computer Science*, 16(13), 1694–1719. Retrieved from



[http://www.jucs.org/jucs\\_16\\_13/toward\\_the\\_next\\_wave/jucs\\_16\\_13\\_1694\\_1719\\_pedrinaci.pdf](http://www.jucs.org/jucs_16_13/toward_the_next_wave/jucs_16_13_1694_1719_pedrinaci.pdf)

- Pedrinaci, C., Domingue, J., & Sheth, A. P. (2011). Semantic Web Services. In *Handbook of Semantic Web Technologies* (pp. 977–1035). Berlin, Heidelberg: Springer Berlin Heidelberg. [https://doi.org/10.1007/978-3-540-92913-0\\_22](https://doi.org/10.1007/978-3-540-92913-0_22)
- Peffers, K., Tuunanen, T., Gengler, C. E., Rossi, M., Hui, W., Virtanen, V., & Bragge, J. (2006). The Design Science Research Process: A Model for Producing and Presenting Information Systems Research. *Proceedings of Design Research in Information Systems and Technology DESRIST'06*, 24, 83–106. <https://doi.org/10.2753/MIS0742-1222240302>
- Peffers, K., Tuunanen, T., Rothenberger, M. A., & Chatterjee, S. (2007). A Design Science Research Methodology for Information Systems Research. *Journal of Management Information Systems*, 24(3), 45–77. <https://doi.org/10.2753/MIS0742-1222240302>
- Peleg, M. (2013). Computer-interpretable clinical guidelines: a methodological review. *J. Biomed. Inform.*, (46), 744–763. <https://doi.org/http://dx.doi.org/10.1016/j.jbi.2013.06.009>
- Peleg, M., Gutnik, L. A., Snow, V., & Patel, V. L. (2006). Interpreting procedures from descriptive guidelines. *J. Biomed. Inform.*, 39, 184–195. <https://doi.org/http://dx.doi.org/10.1016/j.jbi.2005.06.002>
- Pokraev, S., Quartel, D., Steen, M. W., & Reichert, M. (2007). Semantic service modeling: Enabling system interoperability. In *Enterprise Interoperability* (pp. 221–230). Springer.
- Pras, A., & Schoenwaelder, J. (2003). *On the Difference between Information Models and Data Models. RFC3444*. IETF Network Working Group. Retrieved from <https://tools.ietf.org/html/rfc3444>
- Prefontaine, S., & Dawes, L. (2003). Understanding new models of collaboration for delivering government services. *Communications of the ACM*, 46(1), 40–42.
- Pries-Heje, J., & Baskerville, R. (2008). The design theory nexus. *MIS Quarterly*, 32(4), 731–755.
- Python Software Foundation. (2018). Python programming language. Retrieved April 10, 2018, from <https://www.python.org/>
- Qin, Y., Lu, W., Qi, Q., Li, T., Huang, M., Scott, P. J., & Jiang, X. (2017). Explicitly representing the semantics of composite positional tolerance for patterns of holes. *The International Journal of Advanced Manufacturing Technology*, 90(5–8), 2121–2137. <https://doi.org/10.1007/s00170-016-9457-8>

- Rada, R., Mili, H., Bicknell, E., & Blettner, M. (1989). Development and application of a metric on semantic nets. *IEEE Transactions on Systems, Man, and Cybernetics*, 19(1), 17–30. <https://doi.org/10.1109/21.24528>
- Rahm, E., & Bernstein, P. A. (2001). A survey of approaches to automatic schema matching. *The VLDB Journal*, 10(4), 334–350. <https://doi.org/10.1007/s007780100057>
- Ram, S., & Jinsoo Park. (2004). Semantic conflict resolution ontology (SCROL): an ontology for detecting and resolving data and schema-level semantic conflicts. *IEEE Transactions on Knowledge and Data Engineering*, 16(2), 189–202. <https://doi.org/10.1109/TKDE.2004.1269597>
- Rankin, J. (2016, June 9). Britain aims to close EU information gap in wake of terror attacks | UK news | The Guardian. Retrieved April 3, 2017, from <https://www.theguardian.com/politics/2016/jun/09/britain-aims-close-eu-information-gap-terror-attacks-theresa-may-database>
- Raskin, R. G., & Pan, M. J. (2005). Knowledge representation in the semantic web for Earth and environmental terminology (SWEET). *Computers & Geosciences*, 31(9), 1119–1125. <https://doi.org/10.1016/j.cageo.2004.12.004>
- Rezaei, R., Chiew, T., Lee, S. (2013). A review of interoperability assessment models. *Journal of Zhejiang University SCIENCE*, 14(9). <https://doi.org/http://dx.doi.org/10.1631/jzus.C1300013>
- Richardson, R., & Smeaton, A. (1996). *An information retrieval approach to locating information in large scale federated database systems* (No. CA-0296). Retrieved from [http://simpr1.compapp.dcu.ie/CA\\_Working\\_Papers/wp96.html](http://simpr1.compapp.dcu.ie/CA_Working_Papers/wp96.html)
- Rodriguez, A. M., Egenhofer, M. J., & Rugg, R. D. (1999). Assessing semantic similarities among geospatial feature class definitions. In *Second international conferences. Zurich, Switzerland: INTEROP'99*. (pp. 189–202).
- Roldán, J. L., & Leal, A. (2003). A validation test of an adaptation of the DeLone and McLean's Model in the Spanish EIS field. In J. J. Cano (Ed.), *Critical Reflections on Information Systems: A Systemic Approach* (pp. 66–84). Hershey, PA, USA, PA, USA: Idea Group Publishing.
- Ronaghan, S. (2002). *Benchmarking e-Government: A Global Perspective*. United Nations American Society for Public Administration. Retrieved from <http://unpan1.un.org/intradoc/groups/public/documents/un/unpan021547.pdf>
- Rubin, K. S. (2012). *Essential Scrum. A Practical guide to the most popular Agile process*. (Addison-Wesley, Ed.) (First).

- Saaranen, M., Parak, J., Honko, H., Aaltonen, T., & Korhonen, I. (2014). W2E - Wellness Warehouse Engine for semantic interoperability of consumer health data. In *IEEE-EMBS International Conference on Biomedical and Health Informatics (BHI)* (pp. 350–354). IEEE. <https://doi.org/10.1109/BHI.2014.6864375>
- Scholl, H. J., & Klischewski, R. (2007). E-government integration and interoperability: Framing the research agenda. *International Journal of Public Administration*, 30(2), 889–920.
- Scholl, H. J., Kubicek, H., Cimander, R., & Klischewski, R. (2012). Process integration, information sharing, and system interoperation in government: A comparative case analysis. *Government Information Quarterly*, 29(3), 313–323. <https://doi.org/10.1016/j.giq.2012.02.009>
- Schooley, B. L., & Horan, T. A. (2007). Towards end-to-end government performance management: Case study of interorganizational information integration in emergency medical services (EMS). *Government Information Quarterly*, 24(4), 755–784. <https://doi.org/10.1016/j.giq.2007.04.001>
- Secrétariat Général de la Mer. (2012). *BlueMassMed. Final report*. Paris, France.
- Sein, M. K. (2011). Action design research. *MIS Quarterly*, 35(1), 37–56.
- Seleng, M., Dlugolinsky, S., Tomasek, M., Furdik, K., & Hluchy, L. (2015). Lightweight Semantic approach for enterprise interoperability issues. In *2015 IEEE 19th International Conference on Intelligent Engineering Systems (INES)* (pp. 395–400). Bratislava, Slovakia: IEEE. <https://doi.org/10.1109/INES.2015.7329741>
- Seleng, M., Laclavik, M., Dlugolinsky, S., Ciglan, M., Tomasek, M., & Hluchy, L. (2014). Approach for enterprise search and interoperability using lightweight semantic. In *IEEE 18th International Conference on Intelligent Engineering Systems INES 2014* (pp. 73–78). Tihany, Hungary: IEEE. <https://doi.org/10.1109/INES.2014.6909373>
- Shalal, A. (2016, July 20). German foreign minister urges more ties between police, spy agencies. *Reuters*. Retrieved from <http://www.reuters.com/article/us-europe-attacks-germany-steinmeier-idUSKCN0ZZ2XE>
- Sheth, A. P. (1999). Changing Focus on Interoperability in Information Systems: From System, Syntax, Structure to Semantics. In *Interoperating Geographic Information Systems* (pp. 5–29). Boston, MA: Springer US. [https://doi.org/10.1007/978-1-4615-5189-8\\_2](https://doi.org/10.1007/978-1-4615-5189-8_2)
- Shvaiko, P., & Euzenat, J. (2005). A Survey of Schema-Based Matching Approaches. *J. Data Semantics*, 4, 146–171.

- Shvaiko, P., & Euzenat, J. (2013). Ontology Matching: State of the Art and Future Challenges. *IEEE Transactions on Knowledge and Data Engineering*, 25(1), 158–176. <https://doi.org/10.1109/TKDE.2011.253>
- Siau, K., & Long, Y. (2005a). Synthesizing e-government stage models — A meta-synthesis based on meta-ethnography approach. *Industrial Management & Data Systems*, 105(4), 443–458.
- Siau, K., & Long, Y. (2005b). Synthesizing e-government stage models — A meta-synthesis based on meta-ethnography approach. *Industrial Management & Data Systems*, 105(3–4), 443–458.
- Simon, H. A. (1996). *The Sciences of the Artificial*. (MIT Press, Ed.) (3rd Ed.). MIT Press.
- Sinaci, A. A., & Laleci Erturkmen, G. B. (2013). A federated semantic metadata registry framework for enabling interoperability across clinical research and care domains. *Journal of Biomedical Informatics*, 46(5), 784–794. <https://doi.org/10.1016/j.jbi.2013.05.009>
- Sonsilphong, S., Arch-int, N., Arch-int, S., & Pattarapongsin, C. (2016). A semantic interoperability approach to health-care data: Resolving data-level conflicts. *Expert Systems*, 33(6), 531–547. <https://doi.org/10.1111/exsy.12167>
- Spaccapietra, S., & Parent, C. (1991). Conflicts and correspondence assertions in interoperable databases. *ACM SIGMOD Record*, 20(4), 49–54. <https://doi.org/10.1145/141356.141379>
- Staab, S., & Studer, R. (2009). *Handbook on Ontologies*. Springer.
- Starsinic, M. (2010). System architecture challenges in the home M2M network. In *2010 IEEE Long Island Systems, Applications and Technology Conference* (pp. 1–7). IEEE. <https://doi.org/10.1109/LISAT.2010.5478336>
- Strassner, J., & Diab, W. W. (2016). A Semantic Interoperability Architecture for Internet of Things Data Sharing and Computing. In *2016 IEEE 3rd World Forum on Internet of Things (WF-IoT)* (pp. 609–614). IEEE. <https://doi.org/10.1109/WF-IoT.2016.7845422>
- Swedish Coast Guard. (2011). *MARSUNO: Final Project Report*. Retrieved from <http://www.statewatch.org/news/2014/jul/eu-2011-marsuno-final-report.pdf>
- Tarboton, D. G., Maidment, D., Zaslavsky, I., Ames, D., Goodall, J., Hooper, R. P., ... Schreuders, K. (2011). Data interoperability in the hydrologic sciences, the CUAHSI hydrologic information system. In *Proceedings of the Environmental Information Management Conference* (pp. 132–137).
- The NIEM Community. (2005). National Information Exchange Model (NIEM).

- The Open Group. (2009). *SOA Source Book* (7th ed.). Van Haren. Retrieved from <http://www.opengroup.org/soa/source-book/intro/>
- The White House. (2007). National Strategy for Information Sharing. Washington, United States of America. Retrieved from <https://georgewbush-whitehouse.archives.gov/nsc/infosharing/>
- The White House. (2012). *National Strategy for Information Sharing and Safeguarding*. Washington. Retrieved from <https://www.ise.gov/sites/default/files/2012infosharingstrategy.pdf>
- Thierauf, R. J. (1999). *Knowledge Management Systems for Business*. Quorum Book. Retrieved from [https://books.google.it/books?id=5Dv82411J-AC&pg=PR3&hl=it&source=gbs\\_selected\\_pages&cad=2#v=onepage&q&f=false](https://books.google.it/books?id=5Dv82411J-AC&pg=PR3&hl=it&source=gbs_selected_pages&cad=2#v=onepage&q&f=false)
- Tremblay, M. C., Hevner, A. R., & Berndt, D. J. (2010). Focus Groups for Artifact Refinement and Evaluation in Design Research. *Communications of the Association for Information Systems (CAIS)*, 26(27).
- Triantaphyllou, E. (2000). Multi-Criteria Decision Making Methods. In *Multi-Criteria Decision Making Methods: A Comparative Study* (pp. 5–21). Springer, US. <https://doi.org/10.1007/978-1-4757-3157-6>
- Tu, S. W., Campbell, J. R., Glasgow, J., Nyman, M. A., McClure, R., & McClay, J. (2007). The SAGE guideline model: achievements and overview. *J. Am. Med. Inform. Assoc.*, (14), 589–598. <https://doi.org/http://dx.doi.org/10.1197/jamia.M2399>
- Tversky, A. (1977). Features of similarity. *Psychological Review*, 84(4), 327–352. <https://doi.org/10.1037/0033-295X.84.4.327>
- United Nations Development Group. (2011). *Results-Based Management Handbook*. United Nations.
- United Nations Security Council. (2016). Statement by the President S/PRST/2016/4. Retrieved from [http://www.securitycouncilreport.org/atf/cf/%7B65BFCF9B-6D27-4E9C-8CD3-CF6E4FF96FF9%7D/s\\_prst\\_2016\\_4.pdf](http://www.securitycouncilreport.org/atf/cf/%7B65BFCF9B-6D27-4E9C-8CD3-CF6E4FF96FF9%7D/s_prst_2016_4.pdf)
- United States Air Force Research Laboratory. (2007). *Semantic Interoperability Capabilities Based Assessment and Technology Roadmap*. Retrieved from <https://pdfs.semanticscholar.org/a6d8/88f0aac698680a7b7d127e23fbd624a26b9.pdf>
- United States Department of Health and Human Services. Health information policy (2014). United States. Retrieved from <http://www.hhs.gov/ocr/privacy/hipaa/administrative/enforcementrule/hitech-enforcement.html>

- UNSC. (2016). *Report of the Secretary - General on the situation with respect to piracy and armed robbery at sea off the coast of Somalia*. Retrieved from [http://www.un.org/en/ga/search/view\\_doc.asp?symbol=S/2016/843](http://www.un.org/en/ga/search/view_doc.asp?symbol=S/2016/843)
- Vaishnavi, V., Kuechler, W., & Petter, S. (2017). Design Science Research in Information Systems. Retrieved December 3, 2017, from <http://desrist.org/design-research-in-information-systems>
- van Aken, J. E. (2004). Management research based on the paradigm of the design sciences: The quest for field-tested and grounded technological rules. *Journal of Management Studies*, 41(2), 219–246.
- van Aken, J. E. (2005). Management research as a design science: Articulating the research products of mode 2 knowledge production in management. *British Journal of Management*, 16(1), 19–36.
- Van Dyck, H. (2016). TED Talk: How a Start-up in the White House is Changing Business as Usual. TED2016. Retrieved from [https://www.ted.com/talks/haley\\_van\\_dyck\\_how\\_a\\_start\\_up\\_in\\_the\\_white\\_house\\_is\\_changing\\_business\\_as\\_usual#t-245607](https://www.ted.com/talks/haley_van_dyck_how_a_start_up_in_the_white_house_is_changing_business_as_usual#t-245607)
- Walton, R. E. (1989). *Up and running: Integrating information technology and the organization*. Boston, MA, USA, MA, USA: Harvard Business School Press.
- Wang, Z., Li, J., Zhao, Y., Setchi, R., & Tang, J. (2013). A unified approach to matching semantic data on the Web. *Knowledge-Based Systems*, 39, 173–184.
- Wright, A., Sittig, D. F., Ash, J. S., Erickson, J. L., Hickman, T. T., Paterno, M., ... Middleton, B. (2015). Lessons learned from implementing service-oriented clinical decision support at four sites: A qualitative study. *International Journal of Medical Informatics*, 84(11), 901–911. <https://doi.org/10.1016/j.ijmedinf.2015.08.008>
- Wunder, M. (2013). *Framework for Semantic Interoperability. Technical Report AC/323(IST-094)TP/525*.
- Yahia, E., Aubry, A., & Panetto, H. (2012). Formal measures for semantic interoperability assessment in cooperative enterprise information systems. *Computers in Industry*, 63(5), 443–457. <https://doi.org/10.1016/j.compind.2012.01.010>
- Yang, T. M., & Wu, Y. J. (2013). What to Share and Why to Share? A Case Study of Cross-Boundary Information Sharing in Taiwan e-Government. *Journal of Library and Information Studies*, 11(1), 25–53.
- Yu, C.-H., & Hunter, J. (2013). Documenting and sharing comparative analyses of 3D digital museum artifacts through semantic web annotations. *Journal on Computing and Cultural Heritage*, 6(4), 1–

20. <https://doi.org/10.1145/2532630.2532634>

Zghal, S., Yahia, S. Ben, Nguifo, E. M., & Slimani, Y. (2007). SODA: an OWL-DL based ontology matching system. In *Proceedings of the 2nd International Conference on Ontology Matching - Volume 304* (pp. 261–267).

Zhang, J., & Dawes, S. S. (2006). Expectations and perceptions of benefits, barriers, and success in public sector knowledge networks. *Public Performance & Management Review*, 29(4), 433–466.

Zhang, J., Dawes, S. S., & Sarkis, J. (2005). Exploring stakeholders' expectations of the benefits and barriers of e-Government knowledge sharing. *Journal of Enterprise Information Management*, 18(5), 548–567.

Zheng, L., & Terpenney, J. (2013). A hybrid ontology approach for integration of obsolescence information. *Computers & Industrial Engineering*, 65(3), 485–499. <https://doi.org/10.1016/j.cie.2013.02.011>

Zhou Xiaoguang, & Long Wei. (2008). The research of network architecture in warehouse management system based on RFID and WSN integration. In *2008 IEEE International Conference on Automation and Logistics* (pp. 2556–2560). IEEE. <https://doi.org/10.1109/ICAL.2008.4636600>

Zins, C. (2007). Conceptual approaches for defining data, information, and knowledge. *Journal of the American Society for Information Science and Technology*, 58(4), 479–493. <https://doi.org/10.1002/asi.20508>

(page intentionally left in blank)





## **Appendixes**

(page intentionally left in blank)

## Appendix 1. Information sharing scenario

In the scenario depicted in the following figure, three different organizations (P1, P2 and P3) are willing to share information by using a common information model (CIM), which comprises seven information elements (I1, I2, I3, I4, I5, I6 and I7). The scenario also entails seven information systems (S $x.y$ , where  $x$  is the organization number and  $y$  is the system number) and two services (T1.2 and T3.1). These services have been developed to transform some of the CIM information elements (I1, I3, I4, I5 and I6) so that they can be consumed and provided as required. The representations of the CIM information elements in each system – the system information elements (each of which can be implemented in practice by different information structures such as classes and attributes) - are enumerated, in between brackets, and the correspondence is established by its index (e.g. S1.1<sub>I1</sub> is the representation of the CIM information element I1 in system S1.1). Consequently, the transformations are performed by the following five distinct functions:

- $S1.2_{I3} = g(I3)$
- $S1.2_{I4} = g(I4)$
- $S3.1_{I6} = g(I6)$
- $S3.2_{I1} = g(I1)$
- $I3 = f(S1.2_{I1})$

Practice shows that, in information sharing initiatives, organizations tend to adopt certain behavioral patterns, three of them being well known. The first is the one where an organization, which has plenty of relevant information, is not interested in any information from the remainder participants, however considers sharing some of the information held with them. The second is the one where an organization has close to no information and is willing to obtain everything available from the remainder participants. Finally, the third pattern is the one where an organization has some information and wishes to get some other from the rest of the organizations involved. In our scenario, these patterns are represented by organizations P2, P3 and P1, respectively. Consequently, while P2 requires no information, participant P1 is willing to obtain some information elements (I3, I4, I5 and I7) and has inclusively already defined the necessary transformations to consume part of those elements (I3, I4) from the CIM, and also to provide I1. Likewise, participant P3 is willing to obtain all the CIM information elements, for which it has already defined the necessary transformations to consume part of them (I5 and I6).

Sometimes organizations have similar information (not duplicated) in different systems. For example, while one system can have information about the geographical location of a fishing vessel, another system can have information about the geographic location of a merchant vessel. While the information elements may be the same, from the CIM point of view (structure), the inherent information is not, which requires both systems to develop semantic interoperability in both systems, as required to provide or to consume that information. This particular situation is herein represented by element I1 in the systems of participant P1.

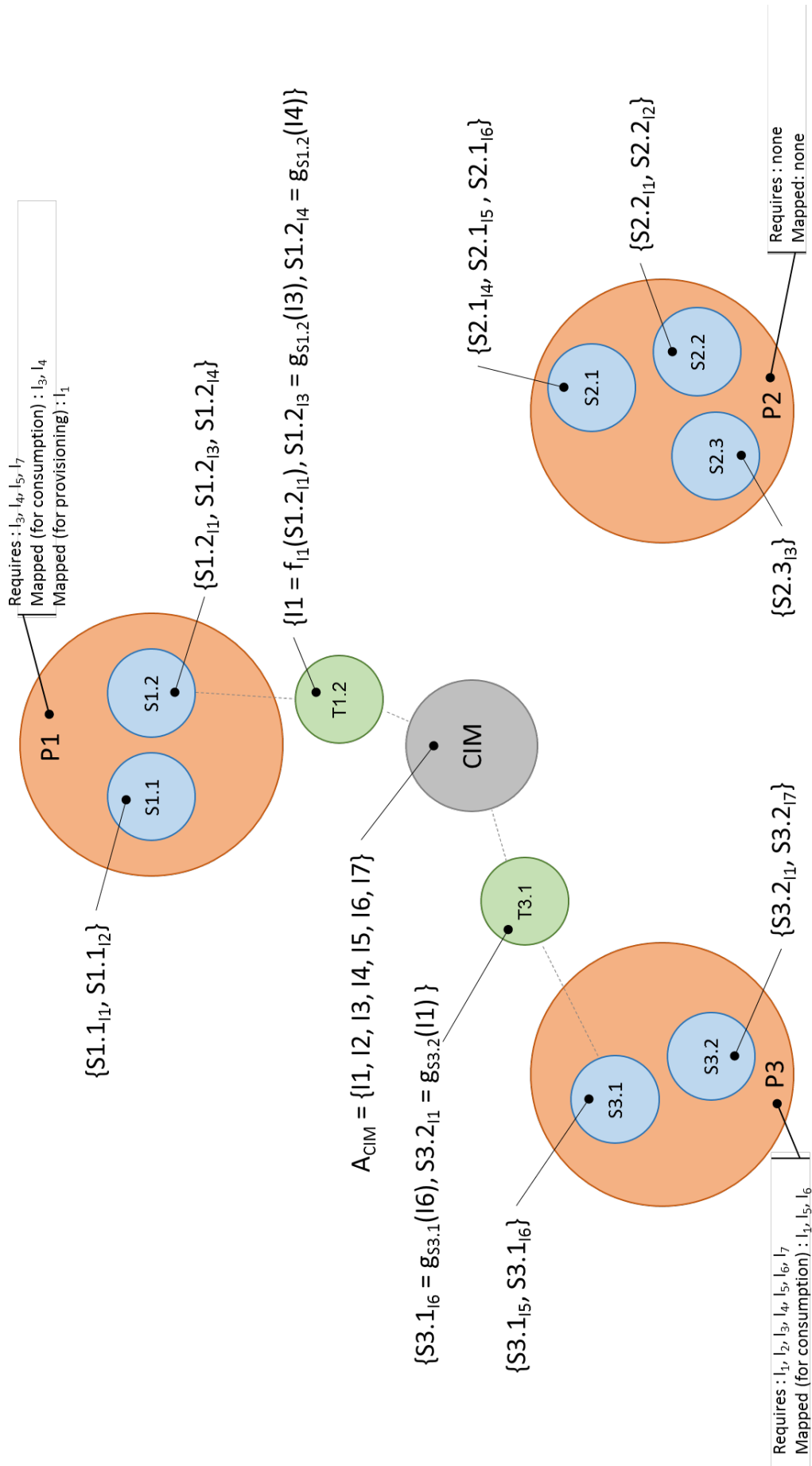

## Appendix 2. Core concepts

### Performance

#### Participants

Table 88: Participants

<i>Name</i>	<i>Participants (P)</i>
<i>Informal definition</i>	Set of all organizations with a role in the information sharing process, which can be that of an information provider, consumer, or both
<i>Formal definition</i>	$P = \{p_1, p_2, p_3, \dots, p_n\}$
<i>Example</i>	$P = \{P1, P2, P3\}$

**Source:** Author

#### Common Information Model

Table 89: Elements of the Common Information Model

<i>Name</i>	<i>CIM elements (E<sub>CIM</sub>)</i>
<i>Informal definition</i>	Set of all CIM information elements
<i>Formal definition</i>	$E_{CIM} = \{a_1, a_2, a_3, \dots, a_n\}$
<i>Example</i>	$E_{CIM} = \{I1, I2, I3, I4, I5, I6, I7\}$

**Source:** Author

## Information systems

Table 90: Systems of a participant

<b>Name</b>	<i>Systems of a participant</i> ( $S_P$ )
<b>Informal definition</b>	Set of the participant's systems which implement CIM elements
<b>Formal definition</b>	$\forall p \in P, \forall n \in \mathbb{N},$  $S_p = \{S_1, S_2, S_3, \dots, S_n\}$
<b>Example</b>	$S_{P1} = \{S1.1, S1.2\}$  $S_{P2} = \{S2.1, S2.2, S2.3\}$  $S_{P3} = \{S3.1, S3.2\}$

**Source:** Author

Table 91: All systems

<b>Name</b>	<i>All systems</i> ( $S$ )
<b>Informal definition</b>	Set of all participants' systems which implement (or are expected to) CIM elements
<b>Formal definition</b>	$S = \bigcup_{i=1}^n S_i$  $\forall i \in \mathbb{N}, \quad n =  P $
<b>Example</b>	$S = \{S1.1, S1.2, S2.1, S2.2, S2.3, S3.1, S3.2\}$

**Source:** Author

## Information transformations

**Table 92:** Transformation services of a participant

<b>Name</b>	<b>Transformation services of a participant (<math>T_P</math>)</b>
<b>Informal definition</b>	Set of all participant services that are used to transform the system elements into the corresponding CIM elements and the other way around.
<b>Formal definition</b>	$\forall p \in P$ $T_p = \{t1, t2, t3, \dots, tn\}$
<b>Example</b>	$T_{p1} = \{T1.2\}$ $T_{p2} = \emptyset$ $T_{p3} = \{T3.1\}$

**Source:** Author

**Table 93:** All transformation services

<b>Name</b>	<b>All transformation services (<math>T</math>)</b>
<b>Informal definition</b>	Set of all transformation services of all participants.
<b>Formal definition</b>	$\forall i \in \mathbb{N}, \forall p \in P$ $T = \bigcup_{i=1}^{ P } T_{p_i}$
<b>Example</b>	$T = \{T1.2, T3.1\}$

**Source:** Author

**Table 94:** Transformation of a system element into a CIM element

<b>Name</b>	<b>Transformation of a system element into a CIM element (<math>f_a</math>)</b>
-------------	---



<i>Informal definition</i>	Function that transforms a system element into its corresponding CIM element (mapping for provisioning)
<i>Formal definition</i>	$\forall s \in S, \forall r \in R_s, \forall a \in A_s$ $f_a: R_s \rightarrow A_s, a = f_a(r)$
<i>Example</i>	$I1 = f_{I1}(S1.2_{I1})$

**Source:** Author

**Table 95:** Transformation of a CIM element into a system element

<b>Name</b>	<b>Transformation of a CIM element into a system element (g)</b>
<i>Informal definition</i>	Function that transforms a CIM element into its corresponding system element (retraction of $f$ ) (mapping for consumption)
<i>Formal definition</i>	$\forall s \in S, \forall r \in R_s, \forall a \in A_{CIM}$ $g: A_s \rightarrow R_s, r = g_s(f(r))$
<i>Example</i>	$S1.2_{I3} = g_{s1.2}(I3)$ $S3.1_{I6} = g_{s3.1}(I6)$ $S1.2_{I4} = g_{s1.2}(I4)$ $S3.2_{I1} = g_{s3.2}(I1)$

**Source:** Author

**Table 96:** Functions of a transformation service

<b>Name</b>	<b>Functions of a transformation service (<math>F_T</math>)</b>
<i>Informal definition</i>	Set of all functions which are implemented in a transformation service
<i>Formal definition</i>	$\forall t \in T$ $F_t = \{f_1, f_2, f_3, \dots, f_n\} \cup \{g_1, g_2, g_3, \dots, g_n\}$
<i>Example</i>	$F_{T1.2} = \{S1.2_{I3} = g_{s1.2}(I3), S1.2_{I4} = g_{s1.2}(I4), I1 = f_{I1}(S1.2_{I1})\}$ $F_{T3.1} = \{S3.1_{I6} = g_{s3.1}(I6), S3.2_{I1} = g_{s3.2}(I1)\}$

**Source:** Author

Information available

**Table 97:** CIM elements available in a system

<b>Name</b>	<b>CIM elements available in a system (<math>EA_S</math>)</b>
<b>Informal definition</b>	Set of the CIM elements implemented in a system
<b>Formal definition</b>	$\forall s \in S,$ $EA_S \subseteq E_{CIM}$
<b>Example</b>	$EA_{S1.1} = \{I1, I2\}$ $EA_{S1.2} = \{I1, I3, I4\}$ $EA_{S2.1} = \{I4, I5, I6\}$ $EA_{S2.2} = \{I1, I2\}$ $EA_{S2.3} = \{I3\}$ $EA_{S3.1} = \{I5, I6\}$ $EA_{S3.2} = \{I1, I7\}$

**Source:** Author

**Table 98:** CIM elements available in a participant

<b>Name</b>	<b>CIM elements available in a participant (<math>EA_P</math>)</b>
<b>Informal definition</b>	Set of all CIM information elements which are implemented in all the systems of a participant
<b>Formal definition</b>	$\forall p \in P, \forall i \in \mathbb{N}, \forall s \in S_p$ $EA_p = \bigcup_{i=1}^{ S_p } EA_{S_i}$
<b>Example</b>	$EA_{P1} = \{I1, I2, I3, I4\}$ $EA_{P2} = \{I1, I2, I3, I4, I5, I6\}$ $EA_{P3} = \{I1, I5, I6, I7\}$

**Source:** Author

**Table 99:** CIM elements in all systems

<b>Name</b>	<b>CIM elements in all systems (<math>E</math>)</b>
-------------	---

<i>Informal definition</i>	Set of all CIM information elements implemented in all systems
<i>Formal definition</i>	$\forall i \in \mathbb{N}, \forall s \in S$ $E = \bigcup_{i=1}^{ S } EA_{Si}$
<i>Example</i>	$E = \{I1, I2, I3, I4, I5, I6, I7\}$

**Source:** Author

**Table 100:** System elements available in a system

<i>Name</i>	<i>System elements available in a system (RA<sub>S</sub>)</i>
<i>Informal definition</i>	Set of all system elements which implement CIM information elements
<i>Formal definition</i>	$\forall s \in S$ $RA_S = \{r_1, r_2, r_3, \dots, r_n\}$
<i>Example</i>	$RA_{S1.1} = \{S1.1_{I1}, S1.1_{I2}\}$ $RA_{S1.2} = \{S1.2_{I1}, S1.2_{I3}, S1.2_{I4}\}$ $RA_{S2.1} = \{S2.1_{I4}, S2.1_{I5}, S2.1_{I6}\}$ $RA_{S2.2} = \{S2.2_{I1}, S2.2_{I2}\}$ $RA_{S2.3} = \{S2.3_{I3}\}$ $RA_{S3.1} = \{S3.1_{I5}, S3.1_{I6}\}$ $RA_{S3.2} = \{S3.2_{I1}, S3.2_{I7}\}$

**Source:** Author

**Table 101:** Participant systems' elements

<i>Name</i>	<i>System elements available in a participant (RA<sub>P</sub>)</i>
<i>Informal definition</i>	Set comprising all the participant systems' information elements which implement CIM information elements
<i>Formal</i>	$\forall s \in S_p, \forall p \in P, \forall i \in \mathbb{N}$

<i>definition</i>	$RA_p = \bigcup_{i=1}^{ S_p } RA_{S_i}$
<i>Example</i>	$R_{p1} = \{S1.1_{I1}, S1.1_{I2}, S1.2_{I1}, S1.2_{I3}, S1.2_{I4}\}$ $R_{p2} = \{S2.1_{I4}, S2.1_{I5}, S2.1_{I6}, S2.2_{I1}, S2.2_{I2}, S2.3_{I3}\}$ $R_{p3} = \{S3.1_{I5}, S3.1_{I6}, S3.2_{I1}, S3.2_{I7}\}$

Information needed

**Table 102:** CIM elements required by a participant

<i>Name</i>	<i>CIM elements needed by a participant (EN<sub>P</sub>)</i>
<i>Informal definition</i>	Set of all CIM elements that a participant needs, regardless of being implemented on its systems or not
<i>Formal definition</i>	$\forall p \in P$ $EN_p \subseteq E_{CIM}$
<i>Example</i>	$ER_{P1} = \{I3, I4, I5, I7\}$ $ER_{P2} = \emptyset$ $ER_{P3} = \{I1, I2, I3, I4, I5, I6, I7\}$

**Source:** Author

**Table 103:** CIM elements needed by all participants

<i>Name</i>	<i>CIM elements needed by all participants (EN)</i>
<i>Informal definition</i>	Set of all CIM elements needed by at all participant
<i>Formal definition</i>	$\forall i \in \mathbb{N}, \forall p \in P$ $EN = \bigcup_{i=1}^{ P } EN_{pi}$

---

*Example*  $ER = \{I1, I2, I3, I4, I5, I6, I7\}$

---

**Source:** Author

## Information required

**Table 104:** CIM elements required by a participant

<i>Name</i>	<i>CIM elements required by a participant (<math>ER_p</math>)</i>
<i>Informal definition</i>	Set of all CIM elements that a participant needs and that are implemented in at least one of its systems
<i>Formal definition</i>	$\forall p \in P$ $ER_p = EN_p \cap EA_p$
<i>Example</i>	$ER_{P1} = \{I3, I4\}$ $ER_{P2} = \emptyset$ $ER_{P3} = \{I1, I5, I6, I7\}$

**Source:** Author

**Table 105:** CIM elements required by a system

<i>Name</i>	<i>CIM elements required by a system (<math>ER_s</math>)</i>
<i>Informal definition</i>	Set of all CIM elements that are required by a system
<i>Formal definition</i>	$\forall s \in S_p, \forall p \in P$ $ER_s = EA_s \cap ER_p$
<i>Example</i>	$ER_{S1.1} = \emptyset$ $ER_{S1.2} = \{I3, I4\}$

	$ER_{S2.1} = ER_{S2.2} = ER_{S2.3} = \emptyset$
	$ER_{S3.1} = \{I5, I6\}$
	$ER_{S3.2} = \{I1, I7\}$
<i>Notes</i>	If a system implements a CIM element that is required by the participant, then inherently the system requires the CIM element
	<b>Source:</b> Author

**Table 106:** System elements required by a system

<i>Name</i>	<i>System elements required by a system (<math>RR_s</math>)</i>
<i>Informal definition</i>	Set of all system elements that implement CIM elements which are required by the participant
<i>Formal definition</i>	$\forall i \in \mathbb{N}, \forall p \in P, \forall s \in S_p, \forall a \in ER_p$ $RR_s = RA_s \cap (\cup_{i=1}^{ ER_p } g_s(a_i))$
<i>Example</i>	$RR_{S1.1} = \emptyset$ $RR_{S1.2} = \{S1.2_{I3}, S1.2_{I4}\}$ $RR_{S2.1} = \emptyset$ $RR_{S2.2} = \emptyset$ $RR_{S2.3} = \emptyset$ $RR_{S3.1} = \{S3.1_{I5}, S3.1_{I6}\}$ $RR_{S3.2} = \{S3.2_{I1}, S3.2_{I7}\}$

**Source:** Author

**Table 107:** System elements required

<i>Name</i>	<i>System elements required by a participant (<math>RR_p</math>)</i>
<i>Informal definition</i>	Set of all participant systems' elements that implement CIM elements which are required by the participant
<i>Formal definition</i>	$\forall i \in \mathbb{N}, \quad \forall p \in P, \quad \forall s \in S_p$ $RR_p = \cup_{i=1}^{ S_p } RR_{S_i}$
<i>Example</i>	$RR_{p1} = \{S1.2_{I3}; S1.2_{I4}\}$ $RR_{p2} = \emptyset$

---

$$RR_{p3} = \{S3.1_{15}; S3.1_{16}; S3.2_{11}; S3.2_{17}\}$$

---

**Source:** Author

## Information mapped

Information mapped for provisioning

**Table 108:** CIM elements mapped for provisioning by a participant

<i>Name</i>	<i>CIM elements mapped for provisioning by a participant (<math>EMP_p</math>)</i>
<i>Informal definition</i>	Set of all CIM elements which transformations for its provisioning have already been defined by a participant
<i>Formal definition</i>	$\forall p \in P$ $EMP_p \subseteq EA_p$
<i>Example</i>	$EMP_{p1} = \{I1\}$ $EMP_{p2} = \emptyset$ $EMP_{p3} = \emptyset$

**Source:** Author

**Table 109:** CIM elements mapped for provisioning by a system

<i>Name</i>	<i>CIM elements mapped for provisioning by a system (<math>EMP_s</math>)</i>
<i>Informal definition</i>	Set of all CIM elements which transformations for its provisioning by a system have already been defined
<i>Formal definition</i>	$\forall p \in P, \forall s \in S$ $EMP_s \subseteq EA_s \cap EMP_p$
<i>Example</i>	$EMP_{s1.2} = \{I1\}$ $EMP_{s1.1} = EMP_{s2.1} = EMP_{s2.2} = EMP_{s2.3} = EMP_{s3.1} = EMP_{s3.2} = \emptyset$

**Source:** Author

**Table 110:** System elements mapped for provisioning

<i>Name</i>	<i>System elements mapped for provisioning by a system (RMP<sub>s</sub>)</i>	
<i>Informal definition</i>	Set of all system elements which mappings to provide the corresponding CIM elements have been defined	
<i>Formal definition</i>	$\forall i \in \mathbb{N}, \forall s \in S, \forall a \in EMP_s$ $RMP_s = \bigcup_{i=1}^{ EMP_s } g_s(a_i)$	
<i>Example</i>	$RMP_{S1.1} = \emptyset$ $RMP_{S1.2} = S1.2_{I1}$ $RMP_{S2.1} = \emptyset$ $RMP_{S2.2} = \emptyset$	$RMP_{S2.3} = \emptyset$ $RMP_{S3.1} = \emptyset$ $RMP_{S3.2} = \emptyset$
<i>Notes</i>	They are available and mapped to be provided, but this does not mean that presently they are not required by any of the participants	

**Source:** Author

**Table 111:** System elements mapped for provisioning by a participant

<i>Name</i>	<i>System elements mapped for provisioning by a participant (RMP<sub>p</sub>)</i>	
<i>Informal definition</i>	Set of all information elements, from all the participant systems, which mappings to provide the corresponding CIM elements have been defined	
<i>Formal definition</i>	$\forall i \in \mathbb{N}, \forall s \in S_p, \forall p \in P$ $RMP_p = \bigcup_{i=1}^{ S_p } RMP_{s_i}$	
<i>Example</i>	$RMP_{p1} = \{S1.2_{I1}\}$ $RMP_{p2} = \emptyset$ $RMP_{p3} = \emptyset$	



**Source:** Author

Information mapped for consumption

**Table 112:** CIM elements mapped for consumption by a participant

<i>Name</i>	<i>CIM elements mapped for consumption by a participant (<math>EMC_p</math>)</i>
<i>Informal definition</i>	Set of all CIM elements which transformations functions for its consumption have already been defined by a participant
<i>Formal definition</i>	$\forall p \in P$ $EMC_p \subseteq EA_p$
<i>Example</i>	$EMC_{P1} = \{I3, I4\}$ $EMC_{P2} = \emptyset$ $EMC_{P3} = \{I1, I6\}$

**Source:** Author

**Table 113:** CIM elements mapped for consumption by a system

<i>Name</i>	<i>CIM elements mapped for consumption by a system (<math>EMC_s</math>)</i>
<i>Informal definition</i>	Set of all CIM elements which transformation functions for its consumption by a system have already been defined by a participant
<i>Formal definition</i>	$\forall p \in P, \forall s \in S_p$ $EMC_s = EA_s \cap EMC_p$
<i>Example</i>	$EMC_{S1.1} = \emptyset$ $EMC_{S1.2} = \{I3, I4\}$ $EMC_{S2.1} = EMC_{S2.2} = EMC_{S2.3} = \emptyset$ $EMC_{S3.1} = \{I6\}$ $EMC_{S3.2} = \{I1\}$

**Source:** Author

**Table 114:** System elements mapped for consumption

<i>Name</i>	<i>System elements mapped for consumption by a system (RMC<sub>s</sub>)</i>
<i>Informal definition</i>	Set of all system elements which mappings to consume the corresponding CIM elements have been defined
<i>Formal definition</i>	$\forall i \in \mathbb{N}, \forall s \in S, \forall a \in EMC_s$ $RMC_s = \bigcup_{i=1}^{ EMC_s } g_s(a_i)$
<i>Example</i>	$RMC_{S1.1} = \emptyset$ $RMC_{S1.2} = \{S1.2_{I3}, S1.2_{I4}\}$ $RMC_{S2.1} = \emptyset$ $RMC_{S2.2} = \emptyset$ $RMC_{S2.3} = \emptyset$ $RMC_{S3.1} = \{S3.1_{I6}\}$ $RMC_{S3.2} = \{S3.2_{I1}\}$

**Source:** Author

**Table 115:** System elements mapped for consumption by a participant

<i>Name</i>	<i>System elements mapped for consumption by a participant (RMC<sub>p</sub>)</i>
<i>Informal definition</i>	Set of all information elements, from all the participant systems, which mappings to consume the corresponding CIM elements have been defined
<i>Formal definition</i>	$\forall i \in \mathbb{N}, \forall s \in S_p, \forall p \in P$ $RMC_p = \bigcup_{i=1}^{ S_p } RMC_{s_i}$
<i>Example</i>	$RMC_{p1} = \{S1.2_{I3}; S1.2_{I4}\}$ $RMC_{p2} = \emptyset$ $RMC_{p3} = \{S3.1_{I6}; S3.2_{I1}\}$

**Source:** Author

## Information to be provided

Information that could be provided (baseline)

**Table 116:** CIM elements that could be provided by a system

<b>Name</b>	<b>CIM elements that could be provided by a system (<math>ECP_S</math>)</b>
<b>Informal definition</b>	Set of the CIM elements: - available (implemented) in the system; - available (implemented) in at least a system of another participant
<b>Formal definition</b>	$\forall i \in \mathbb{N}, \forall s \in S, \forall k \in S \setminus s$ $ECP_S = EA_s \cap (\bigcup_{i=1}^{ S \setminus s } EA_{k_i})$
<b>Example</b>	$ECP_{S1.1} = \{I1, I2\}$ $ECP_{S1.2} = \{I1, I3, I4\}$ $ECP_{S2.1} = \{I4, I5, I6\}$ $ECP_{S2.2} = \{I1, I2\}$ $ECP_{S2.3} = \{I3\}$ $ECP_{S3.1} = \{I5, I6\}$ $ECP_{S3.2} = \{I1\}$

**Source:** Author

**Table 117:** CIM elements that could be provided by a participant

<b>Name</b>	<b>CIM elements that could be provided by a participant (<math>ECP_P</math>)</b>
<b>Informal definition</b>	Set of the CIM elements: - available (implemented) in all the systems of the participant; - available (implemented) in in at least a system of another participant
<b>Formal definition</b>	$\forall p \in P, \forall i \in \mathbb{N}, \forall s \in S_p$ $ECP_p = \bigcup_{i=1}^{ S_p } ECP_{S_i}$
<b>Example</b>	$ECP_{P1} = \{I1, I1, I2, I3, I4\}$ $ECP_{P2} = \{I1, I2, I3, I4, I5, I6\}$ $ECP_{P3} = \{I1, I5, I6\}$

**Source:** Author

**Table 118:** System elements that could provide information to other systems

<i>Name</i>	<i>System elements that could be provided by a system (RCP<sub>s</sub>)</i>
<i>Informal definition</i>	Set of all system elements which implement CIM information elements
<i>Formal definition</i>	$\forall i \in \mathbb{N}, \forall s \in S, \forall a \in ECP_s$ $RCP_s = \bigcup_{i=1}^{ ECP_s } g_s(a_i)$
<i>Example</i>	$RCP_{S1.1} = \{S1.1_{11}, S1.1_{12}\}$ $RCP_{S1.2} = \{S1.2_{11}, S1.2_{13}, S1.2_{14}\}$ $RCP_{S2.1} = \{S2.1_{14}, S2.1_{15}, S2.1_{16}\}$ $RCP_{S2.2} = \{S2.2_{11}, S2.2_{12}\}$ $RCP_{S2.3} = \{S2.3_{13}\}$ $RCP_{S3.1} = \{S3.1_{15}, S3.1_{16}\}$ $RCP_{S3.2} = \{S3.2_{11}\}$

**Source:** Author

**Table 119:** Participant systems' elements that could provide information to other systems

<i>Name</i>	<i>Participant systems' elements that could provide information to other systems (RCP<sub>p</sub>)</i>
<i>Informal definition</i>	Set comprising all the participant systems' information elements which implement CIM information elements
<i>Formal definition</i>	$\forall s \in S_p, \forall p \in P, \forall i \in \mathbb{N}$ $RCP_p = \bigcup_{i=1}^{ S_p } RCP_{S_i}$
<i>Example</i>	$RCP_{p1} = \{S1.1_{11}, S1.1_{12}, S1.2_{11}, S1.2_{13}, S1.2_{14}\}$ $RCP_{p2} = \{S2.1_{14}, S2.1_{15}, S2.1_{16}, S2.2_{11}, S2.2_{12}, S2.3_{13}\}$ $RCP_{p3} = \{S3.1_{15}, S3.1_{16}, S3.2_{11}, S3.2_{17}\}$

**Source:** Author

Information that should be provided (potential performance)

**Table 120:** CIM elements that should be provided by a system

<i>Name</i>	<i>CIM elements that should be provided by a system (ESP<sub>s</sub>)</i>
<i>Informal definition</i>	Set of all CIM elements that are: - available (implemented) in the system; - available (implemented) in at least one system of another participant - required by the participants that already implement them in their systems
<i>Formal definition</i>	$\forall i \in \mathbb{N}, \forall s \in S, \forall k \in S \setminus s$ $ESP_s = ECP_s \cap (\bigcup_{i=1}^{ S \setminus s } ER_{k_i})$
<i>Example</i>	$ESP_{S1.1} = \{I1\}; ESP_{S1.2} = \{I1\}$ $ESP_{S2.1} = \{I4, I5, I6\}; ESP_{S2.2} = \{I1\}; ESP_{S2.3} = \{I3\}$ $ESP_{S3.1} = \emptyset; ESP_{S3.2} = \emptyset$

**Source:** Author

**Table 121:** System elements that should be provided by a participant

<i>Name</i>	<i>CIM elements that should be provided by a participant (ESP<sub>p</sub>)</i>
<i>Informal definition</i>	Set of all CIM elements that are: - available (implemented) in the systems of the participant; - available (implemented) in at least one system of another participant - required by the participants that already implement them in their systems
<i>Formal definition</i>	$\forall p \in P, \forall i \in \mathbb{N}, \forall s \in S_p$ $ESP_p = \bigcup_{i=1}^{ S_p } ESP_{s_i}$
<i>Example</i>	$ESP_{P1} = \{I1\}$ $ESP_{P2} = \{I1, I3, I4, I5, I6\}$ $ESP_{P3} = \emptyset$

**Source:** Author

**Table 122:** System elements that should be provided

<i>Name</i>	<i>System elements that should be provided by a system (RSP<sub>s</sub>)</i>
<i>Informal definition</i>	<p>Set of all system elements:</p> <ul style="list-style-type: none"> <li>- that implement a CIM element in the system</li> <li>- where the CIM element implemented is also implemented by at least another participant</li> <li>- where the CIM element implemented is required by the participants that already implement it in their systems</li> </ul>
<i>Formal definition</i>	<p><math>\forall s \in S, \forall a \in ESP_s, \forall i \in \mathbb{N}</math></p> $RSP_s = \bigcup_{i=1}^{ ESP_s } g_s(a_i)$
<i>Example</i>	<p><math>RSP_{S1.1} = \{S1.1_{11}\}; RSP_{S1.2} = \{S1.2_{11}\}</math>  <math>RSP_{S2.1} = \{S2.1_{14}, S2.1_{15}, S2.1_{16}\}; RSP_{S2.2} = \{S2.2_{11}\}; RSP_{S2.3} = \{S2.3_{13}\}</math>  <math>RSP_{S3.1} = \emptyset; RSP_{S3.2} = \emptyset</math></p>

**Source:** Author

**Table 123:** System elements that should be provided by a participant

<i>Name</i>	<i>System elements that should be provided by a participant (RSP<sub>p</sub>)</i>
<i>Informal definition</i>	<p>Set of all system elements:</p> <ul style="list-style-type: none"> <li>- that implement a CIM element in the systems of the participant</li> <li>- where the CIM element implemented is also implemented by at least another participant</li> <li>- where the CIM element implemented is required by the participants that already implement it in their systems</li> </ul>
<i>Formal definition</i>	<p><math>\forall p \in P, \forall i \in \mathbb{N}, \forall s \in S_p</math></p> $RSP_p = \bigcup_{i=1}^{ S_p } RSP_{S_i}$
<i>Example</i>	<p><math>RSP_{p1} = \{S1.1_{11}, S1.2_{11}\}</math>  <math>RSP_{p2} = \{S2.1_{14}, S2.1_{15}, S2.1_{16}, S2.2_{11}, S2.3_{13}\}</math></p>

$$RSP_{p3} = \emptyset$$

**Source:** Author

Information that must be provided (actual performance)

**Table 124:** CIM elements that must be provided by a system

<i>Name</i>	<i>CIM elements that must be provided by a system (EHP<sub>s</sub>)</i>
<i>Informal definition</i>	Set of all CIM elements that: <ul style="list-style-type: none"> <li>- are available (implemented) in the system;</li> <li>- are available (implemented) in at least one system of another participant</li> <li>- are required by the participants that already implement it in their systems</li> <li>- the transformations to provide them from this system have been defined</li> </ul>
<i>Formal definition</i>	$\forall s \in S$ $EHP_s = ESP_s \cap EMP_s$
<i>Example</i>	$EHP_{s1.1} = EHP_{s2.1} = EHP_{s2.2} = EHP_{s2.3} = EHP_{s3.1} = EHP_{s3.2} = \emptyset$ $EHP_{s1.2} = I1$
<b>Source:</b> Author	

**Table 125:** CIM elements that must be provided by a participant

<i>Name</i>	<i>CIM elements that must be provided by a participant (EHP<sub>p</sub>)</i>
<i>Informal definition</i>	Set of all CIM elements that: <ul style="list-style-type: none"> <li>- are available (implemented) in the systems of the participant;</li> <li>- are available (implemented) in at least one system of another participant</li> <li>- are required by the participants that already implement it in their systems</li> <li>- the transformations to provide them from the systems where they are implemented have been defined</li> </ul>
<i>Formal definition</i>	$\forall p \in P, \forall s \in S_p, \forall i \in \mathbb{N}$ $EHP_p = \bigcup_{i=1}^{ S_p } EHP_{s_i}$
<i>Example</i>	$EHP_{p1} = I1$ $EHP_{p2} = \emptyset$ $EHP_{p3} = \emptyset$

**Source:** Author

**Table 126:** System elements that must be provided by a system

<i>Name</i>	<i>System elements that must be provided by a system (RHP<sub>s</sub>)</i>
<i>Informal definition</i>	Set of all system elements in the system: - that implement a CIM element - which CIM element implemented is implemented by at least another participant - which CIM element implemented is required by the participants implement it - which transformations to provide it have been defined
<i>Formal definition</i>	$\forall s \in S$  $RHP_s = RSP_s \cap RMP_s$
<i>Example</i>	$RHP_{S1.1} = RHP_{S2.1} = RHP_{S2.2} = RHP_{S2.3} = RHP_{S3.1} = RHP_{S3.2} = \emptyset$ $RHP_{S1.2} = S1.2_{I1}$

**Source:** Author

**Table 127:** System elements that must be provided by a participant

<i>Name</i>	<i>System elements that must be provided by a participant (RHP<sub>p</sub>)</i>
<i>Informal definition</i>	Set of all system elements in the systems of the participant: - that implement a CIM element - which CIM element implemented is implemented by at least another participant - which CIM element implemented is required by the participants implement it - which transformations to provide it have been defined
<i>Formal definition</i>	$\forall p \in P, \forall i \in \mathbb{N}, \forall s \in S_p$  $RHP_p = \bigcup_{i=1}^{ S_p } RHP_{S_i}$
<i>Example</i>	$RHP_{P1} = \{S1.2_{I1}\}$ $RHP_{P2} = \emptyset$ $RHP_{P3} = \emptyset$



**Source:** Author

## Information to be consumed

Information that could be consumed (baseline)

**Table 128:** CIM elements that could be consumed by a system

<i>Name</i>	<i>CIM elements that could be consumed by a system (<math>ECC_s</math>)</i>		
<i>Informal definition</i>	Set of all CIM elements that: - are available in the system  - are available in at least a system of another participant		
<i>Formal definition</i>	$\forall i \in \mathbb{N}, \forall s \in S, \forall k \in S \setminus s$ $ECC_S = EA_s \cap \left( \bigcup_{i=1}^{ S \setminus s } EA_{k_i} \right)$		
<i>Example</i>	$ECC_{S1.1} = \{I1, I2\}$ $ECC_{S1.2} = \{I1, I3, I4\}$	$ECC_{S2.1} = \{I4, I5, I6\}$ $ECC_{S2.2} = \{I1, I2\}$ $ECC_{S2.3} = \{I3\}$	$ECC_{S3.1} = \{I5, I6\}$ $ECC_{S3.2} = \{I1\}$

**Source:** Author

**Table 129:** CIM elements that could be consumed by a participant

<i>Name</i>	<i>CIM elements that could be consumed by a participant (<math>ECC_P</math>)</i>		
<i>Informal definition</i>	Set of all CIM elements that: - are available in the systems of the participant  - are available in at least a system of another participant		
<i>Formal definition</i>	$\forall i \in \mathbb{N}, \forall p \in P, \forall s \in S_p$ $ECC_P = \bigcup_{i=1}^{ S_p } ECC_{s_i}$		
<i>Example</i>	$ECC_{P1} = \{I1, I1, I2, I3, I4\}$ $ECC_{P2} = \{I1, I2, I3, I4, I5, I6\}$ $ECC_{P3} = \{I1, I5, I6\}$		

**Source:** Author

**Table 130:** System elements that could consume from other systems

<i>Name</i>	<i>System elements that could consume from other systems (RCC<sub>s</sub>)</i>
<i>Informal definition</i>	Set of all system's elements: - that implement a CIM element  - which CIM element implemented is also implemented by at least another participant
<i>Formal definition</i>	$\forall s \in S, \forall a \in ECC_s, \forall i \in \mathbb{N}$ $RCC_s = \bigcup_{i=1}^{ ECC_s } g_s(a_i)$
<i>Example</i>	$RCC_{S1.1} = \{S1.1_{11}, S1.1_{12}\}$ $RCC_{S1.2} = \{S1.2_{11}, S1.2_{13}, S1.2_{14}\}$ $RCC_{S2.1} = \{S2.1_{14}, S2.1_{15}, S2.1_{16}\}$ $RCC_{S2.2} = \{S2.2_{11}, S2.2_{12}\}$ $RCC_{S2.3} = \{S2.3_{13}\}$ $RCC_{S3.1} = \{S3.1_{15}, S3.1_{16}\}$ $RCC_{S3.2} = \{S3.2_{11}\}$

**Source:** Author

**Table 131:** Participant systems' elements that could consume from other systems

<i>Name</i>	<i>Participant systems' elements that could consume from other systems (RCC<sub>p</sub>)</i>
<i>Informal definition</i>	Set comprising all the system elements of a participant: - that implement a CIM element  - which CIM element implemented is also implemented by at least another participant
<i>Formal definition</i>	$\forall p \in P, \forall i \in \mathbb{N}, \forall s \in S_p$ $RCC_p = \bigcup_{i=1}^{ S_p } RCC_{S_i}$
<i>Example</i>	$RCC_{P1} = \{S1.1_{11}, S1.1_{12}, S1.2_{11}, S1.2_{13}, S1.2_{14}\}$ $RCC_{P2} = \{S2.1_{14}, S2.1_{15}, S2.1_{16}, S2.2_{11}, S2.2_{12}, S2.3_{13}\}$

$RCC_{P3} = \{S3.1_{I5}, S3.1_{I6}, S3.2_{I1}\}$

**Source:** Author

Information that should be consumed (potential performance)

**Table 132:** CIM elements that should be consumed by a system

<i>Name</i>	<i>CIM elements that should be consumed by a system (<math>ESC_S</math>)</i>
<i>Informal definition</i>	Set of all CIM elements that: <ul style="list-style-type: none"> <li>- are available (implemented) in the system;</li> <li>- are available (implemented) in at least one system of another participant</li> <li>- is required by the participant</li> </ul>
<i>Formal definition</i>	$\forall i \in \mathbb{N}, \forall s \in S, \forall k \in S \setminus s$ $ESC_S = ECC_S \cap \left( \bigcup_{i=1}^{ S \setminus s } ER_{k_i} \right)$
<i>Example</i>	$ESC_{S1.2} = \{I3, I4\}$ $ESC_{S3.1} = \{I5, I6\}$ $ESC_{S3.2} = \{I1\}$ $ESC_{S1.1} = ESC_{S2.1} = ESC_{S2.2} = ESC_{S2.3} = \emptyset$

**Source:** Author

**Table 133:** CIM elements that should be consumed by a participant

<i>Name</i>	<i>CIM elements that should be consumed by a participant (<math>ESC_P</math>)</i>
<i>Informal definition</i>	Set of all CIM elements that : <ul style="list-style-type: none"> <li>- are available (implemented) in the participant systems;</li> <li>- are available (implemented) in at least one system of another participant</li> <li>- are required by the participant</li> </ul>
<i>Formal definition</i>	$\forall p \in P, \forall i \in \mathbb{N}, \forall s \in S_p$ $ESC_p = \bigcup_{i=1}^{ S_p } ESC_{S_i}$

**Source:** Author

*Example*  $ESC_{P1} = \{I3, I4\}$   
 $ESC_{P2} = \emptyset$   
 $ESC_{P3} = \{I1, I5, I6\}$

**Table 134:** System elements that should be consumed by a system

<i>Name</i>	<i>System elements that should consume from other systems (RSC<sub>s</sub>)</i>								
<i>Informal definition</i>	Set of the system elements : - that implement a CIM element - which CIM element implemented is also implemented by at least another participant - which CIM element implemented is required by the participant								
<i>Formal definition</i>	$\forall s \in S, \forall a \in ESC_s, \forall i \in \mathbb{N}$ $RSC_s = \bigcup_{i=1}^{ ESC_s } g_s(a_i)$								
<i>Example</i>	<table style="width: 100%; border: none;"> <tr> <td style="width: 50%; border: none;"><math>RSC_{S1.1} = \emptyset</math></td> <td style="width: 50%; border: none;"><math>RSC_{S2.3} = \emptyset</math></td> </tr> <tr> <td style="border: none;"><math>RSC_{S1.2} = \{S1.2_{I3}, S1.2_{I4}\}</math></td> <td style="border: none;"><math>RSC_{S3.1} = \{S3.1_{I5}, S3.1_{I6}\}</math></td> </tr> <tr> <td style="border: none;"><math>RSC_{S2.1} = \emptyset</math></td> <td style="border: none;"><math>RSC_{S3.2} = \{S3.2_{I1}\}</math></td> </tr> <tr> <td style="border: none;"><math>RSC_{S2.2} = \emptyset</math></td> <td style="border: none;"></td> </tr> </table>	$RSC_{S1.1} = \emptyset$	$RSC_{S2.3} = \emptyset$	$RSC_{S1.2} = \{S1.2_{I3}, S1.2_{I4}\}$	$RSC_{S3.1} = \{S3.1_{I5}, S3.1_{I6}\}$	$RSC_{S2.1} = \emptyset$	$RSC_{S3.2} = \{S3.2_{I1}\}$	$RSC_{S2.2} = \emptyset$	
$RSC_{S1.1} = \emptyset$	$RSC_{S2.3} = \emptyset$								
$RSC_{S1.2} = \{S1.2_{I3}, S1.2_{I4}\}$	$RSC_{S3.1} = \{S3.1_{I5}, S3.1_{I6}\}$								
$RSC_{S2.1} = \emptyset$	$RSC_{S3.2} = \{S3.2_{I1}\}$								
$RSC_{S2.2} = \emptyset$									

**Source:** Author

**Table 135:** System elements that should be consumed by a participant

<i>Name</i>	<i>Participant systems' elements that should consume from other systems (RSC<sub>p</sub>)</i>						
<i>Informal definition</i>	Set of the participant systems' elements: - that implement a CIM element - which CIM element implemented is also implemented by at least another participant - which CIM element implemented is required by the participant						
<i>Formal definition</i>	$\forall p \in P, \forall i \in \mathbb{N}, \forall s \in S_p$ $RSC_p = \bigcup_{i=1}^{ S_p } RSC_{S_i}$						
<i>Example</i>	<table style="width: 100%; border: none;"> <tr> <td style="width: 50%; border: none;"><math>RSC_{P1} = \{S1.2_{I3}, S1.2_{I4}\}</math></td> <td style="width: 50%; border: none;"></td> </tr> <tr> <td style="border: none;"><math>RSC_{P2} = \emptyset</math></td> <td style="border: none;"></td> </tr> <tr> <td style="border: none;"><math>RSC_{P3} = \{S3.1_{I5}, S3.1_{I6}, S3.2_{I1}\}</math></td> <td style="border: none;"></td> </tr> </table>	$RSC_{P1} = \{S1.2_{I3}, S1.2_{I4}\}$		$RSC_{P2} = \emptyset$		$RSC_{P3} = \{S3.1_{I5}, S3.1_{I6}, S3.2_{I1}\}$	
$RSC_{P1} = \{S1.2_{I3}, S1.2_{I4}\}$							
$RSC_{P2} = \emptyset$							
$RSC_{P3} = \{S3.1_{I5}, S3.1_{I6}, S3.2_{I1}\}$							

**Source:** Author

Information that must be consumed (actual performance)

**Table 136:** CIM elements that must be consumed by a system

<i>Name</i>	<i>CIM elements that must be consumed by a system (<math>EHC_s</math>)</i>
<i>Informal definition</i>	Set of all CIM elements: <ul style="list-style-type: none"> <li>- that are available in the system</li> <li>- that are available in at least a system of another participant</li> <li>- that are required by the participant</li> <li>- which transformations to be consumed by this system have been defined</li> </ul>
<i>Formal definition</i>	$\forall p \in P$ $EHC_s = ESC_s \cap EMC_s$
<i>Example</i>	$EHC_{S1.2} = \{I3, I4\}$ $EHC_{S3.1} = \{I6\}$ $EHC_{S3.2} = \{I1\}$ $EHC_{S1.1} = EHC_{S2.1} = EHC_{S2.2} = EHC_{S2.3} = \emptyset$

**Source:** Author

**Table 137:** CIM elements that must be consumed by a participant

<i>Name</i>	<i>CIM elements that must be consumed by a participant (<math>EHC_p</math>)</i>
<i>Informal definition</i>	Set of all CIM elements: <ul style="list-style-type: none"> <li>- that are available in the participant systems</li> <li>- that are available in at least a system of another participant</li> <li>- that are required by the participant</li> <li>- which transformations to be consumed by the respective systems have been defined</li> </ul>
<i>Formal definition</i>	$\forall p \in P, \forall i \in \mathbb{N}, \forall s \in S_p$

$$EHC_p = \bigcup_{i=1}^{|S_p|} EHC_{S_i}$$

*Example*  $EHC_{P1} = \{I3, I4\}$

$EHC_{P2} = \emptyset$

$EHC_{P3} = \{I1, I6\}$

**Source:** Author

**Table 138:** System elements that must consume from other systems

<i>Name</i>	<i>System elements that must consume from other systems (RHC<sub>S</sub>)</i>
<i>Informal definition</i>	Set of system elements: - that implement a CIM element - which CIM element implemented is also implemented by at least another participant - which CIM element implemented is required by the participant - which transformations to consume from the CIM have been defined
<i>Formal definition</i>	$\forall s \in S$ $RHC_s = RSC_s \cap RMC_s$
<i>Example</i>	$RHC_{S1.1} = \emptyset$ $RHC_{S1.2} = \{S1.2I3, S1.2I4\}$ $RHC_{S2.1} = \emptyset$ $RHC_{S2.2} = \emptyset$ $RHC_{S2.3} = \emptyset$ $RHC_{S3.1} = \{S3.1I6\}$ $RHC_{S3.2} = \{S3.2I1\}$

**Source:** Author

**Table 139:** Participant systems' elements that must consume from other systems

<i>Name</i>	<i>Participant systems' elements that must consume from other systems (RHC<sub>p</sub>)</i>
<i>Informal definition</i>	Set of system elements from all the systems of the participant : - that implement a CIM element - which CIM element implemented is also implemented by at least another participant - which CIM element implemented is required by the participant - which transformations to consume from the CIM have been defined
<i>Formal definition</i>	$\forall p \in P, \forall s \in S_p, \forall i \in \mathbb{N}$ $RHC_p = \bigcup_{i=1}^{ S_p } RHC_{S_i}$

*Example*  $RHC_{P1} = \{S1.2_{I3}, S1.2_{I4}\}$   
 $RHC_{P2} = \emptyset$   
 $RHC_{P3} = \{S3.1_{I6}, S3.2_{I1}\}$

## Relevance

Factors, weight and relevance

**Table 140:** Factors

<i>Name</i>	<i>Factors (F)</i>
<i>Informal definition</i>	Set of all business factors for which the information contributes
<i>Formal definition</i>	$F = \{f_1, f_2, f_3, \dots, f_n\}$
<i>Example</i>	$F = \{F1, F2, F3\}$

**Source:** Author

**Table 141:** Factor weight

<i>Name</i>	<i>Factor weight (W<sub>f</sub>)</i>
<i>Informal definition</i>	Relative weight of each business factor
<i>Formal definition</i>	$W_f = \{w_1, w_2, w_3, \dots, w_n\}$
<i>Example</i>	$W_{F1} = 0.5; W_{F2} = 0.3; W_{F3} = 0.2$

**Source:** Author

**Table 142:** CIM element relevance

<i>Name</i>	<i>CIM element relevance (R<sub>af</sub>)</i>
<i>Informal</i>	Relevance of each information element to each business factor (as defined by the

*definition* experts)

*Formal definition*  $R_{af} = \{r_{11F1}, r_{11F2}, r_{11F3}, \dots, r_{nm}\}$   
(for each n and m...)

*Example*  $R_{11F1} = 4; R_{11F2} = 3; R_{11F3} = 2$

$R_{12F1} = 3; R_{12F2} = 2; R_{12F3} = 1$

$R_{13F1} = 2; R_{13F2} = 1; R_{13F3} = 0$

$R_{14F1} = 1; R_{14F2} = 0; R_{14F3} = 4$

$R_{15F1} = 0; R_{15F2} = 4; R_{15F3} = 3$

$R_{16F1} = 4; R_{16F2} = 3; R_{16F3} = 2$

$R_{17F1} = 3; R_{17F2} = 2; R_{17F3} = 1$

**Source:** Author

**Table 143:** CIM element weighed relevance

*Name* **CIM element weighed relevance ( $WR_a$ )**

*Informal definition* Overall relevance of a CIM element to all business factors considered

*Formal definition*  $\forall i \in \mathbb{N}, \forall a \in E_{CIM}, \forall f \in F$   
$$WR_a = \sum_{i=1}^{|F|} (R_{af_i} * W_{f_i})$$

*Example*  $WR_{11} = 3,1; WR_{12} = 2,3; WR_{13} = 1,3;$   
 $WR_{14} = 1,3; WR_{15} = 1,8; WR_{16} = 3,3; WR_{17} = 2,3$

**Source:** Author

Other concepts



**Table 144:** Systems' elements implementing CIM elements

<b>Name</b>	<b>Systems' elements implementing CIM elements (AR)</b>
<b>Informal definition</b>	All systems' elements which implement CIM elements
<b>Formal definition</b>	$AR = \bigcup_{i=1}^{ S } R_i$ $\forall i \in \mathbb{N}$
<b>Example</b>	AR = S1.1 <sub>11</sub> , S1.1 <sub>12</sub> , ... S3.2 <sub>17</sub>

**Source:** Author**Table 145:** System containing a system element

<b>Name</b>	<b>System containing a system element (h)</b>
<b>Informal definition</b>	System which contains a particular system element
<b>Formal definition</b>	$h(a) = s$ $\forall a \in AR, \quad \forall s \in S$
<b>Example</b>	$h(S1.1_{11}) = S1.1$

**Source:** Author**Table 146:** Systems elements that will consume a specific system element

<b>Name</b>	<b>Systems elements that should consume a specific system element (RSC<sub>r</sub>)</b>
<b>Informal definition</b>	Set of all systems' elements that should consume a specific system element
<b>Formal definition</b>	$\bigcup_{i=1}^{ S } \bigcup_{j=1}^{ RSC_i } (a \cap RSC_j)$ $\forall a \in AR, \quad \forall i, j \in \mathbb{N}$
<b>Example</b>	$RSC_{S1.1_{11}} = S3.2_{11}; RSC_{S1.1_{12}} = 0;$ $RSC_{S1.2_{11}} = S3.2_{11}; RSC_{S1.2_{13}} = 0; RSC_{S1.2_{14}} = 0;$

**Source:** Author

$$\begin{aligned} &RSC_{S2.1\ 14} = S1.2_{14}; RSC_{S2.1\ 15} = S3.1_{15}; RSC_{S2.1\ 16} = S3.1_{16}; \\ &RSC_{S2.2\ 11} = S3.2_{11}; RSC_{S2.2\ 12} = 0; \\ &RSC_{S2.3\ 13} = S1.2_{13}; \\ &RSC_{S3.1\ 15} = 0; RSC_{S3.1\ 16} = 0; \\ &RSC_{S3.2\ 11} = 0; RSC_{S3.2\ 17} = 0; \end{aligned}$$

**Table 147:** Mapped systems elements that will consume a specific system element

<b>Name</b>	<b><i>Mapped systems elements that must consume a specific system element (RHC<sub>e</sub>)</i></b>		
<b>Informal definition</b>	Set of all mapped systems' elements that must consume a specific system element		
<b>Formal definition</b>	$\forall a \in AR$ $MAC_a \subseteq AC_a$		
<b>Example</b>	$AC_{S1.1\ 11} = S3.2_{11}$ $AC_{S1.1\ 12} = 0$ $AC_{S1.2\ 11} = S3.2_{11}$ $AC_{S1.2\ 13} = 0$ $AC_{S1.2\ 14} = 0$	$AC_{S2.1\ 14} = S1.2_{14}$ $AC_{S2.1\ 15} = 0$ $AC_{S2.1\ 16} = S3.1_{16}$ $AC_{S2.2\ 11} = S3.2_{11}$ $AC_{S2.2\ 12} = 0$ $AC_{S2.3\ 13} = S1.2_{13}$	$AC_{S3.1\ 15} = 0$ $AC_{S3.1\ 16} = 0$ $AC_{S3.2\ 11} = 0$ $AC_{S3.2\ 17} = 0$

**Source:** Author

**Table 148:** Participant which owns a specific system element

<b>Name</b>	<b><i>Participant which owns a specific system element (I<sub>e</sub>)</i></b>		
<b>Informal definition</b>	Participant which owns a specific system information element		
<b>Formal definition</b>	$\forall a \in AR, \quad \forall p \in P$ $l(a) = p$		
<b>Example</b>	$l(S1.1_{11}) = P1$		

**Source:** Author

**Table 149:** Systems consuming a specific system element

<i>Name</i>	<i>Systems that should consume a specific system element (<math>SSC_e</math>)</i>		
<i>Informal definition</i>	Set of all systems which will consume a specific system element		
<i>Formal definition</i>	$\forall e \in ER$ $SSC_e = h(ESC_e)$		
<i>Example</i>	$CS_{S1.1\ 11} = S3.2$ $CS_{S1.1\ 12} = 0$ $CS_{S1.2\ 11} = S3.2$ $CS_{S1.2\ 13} = 0$ $CS_{S1.2\ 14} = 0$	$CS_{S2.1\ 14} = S1.2$ $CS_{S2.1\ 15} = S3.1$ $CS_{S2.1\ 16} = S3.1$ $CS_{S2.2\ 11} = S3.2$ $CS_{S2.2\ 12} = 0$ $CS_{S2.3\ 13} = S1.2$	$CS_{S3.1\ 15} = 0$ $CS_{S3.1\ 16} = 0$ $CS_{S3.2\ 11} = 0$ $CS_{S3.2\ 17} = 0$

**Source:** Author

**Table 150:** Participants consuming a specific system element

<i>Name</i>	<i>Participants that should consume a specific system element (<math>SSP_e</math>)</i>		
<i>Informal definition</i>	Set of all participants which should consume a specific system element		
<i>Formal definition</i>	$\forall e \in ER, \quad \forall i \in \mathbb{N}$ $SSP_e = \bigcup_{i=1}^{ S } l(SSS_e)$		
<i>Example</i>	$CP_{S1.1\ 11} = P3$ $CP_{S1.1\ 12} = 0$ $CP_{S1.2\ 11} = P3$ $CP_{S1.2\ 13} = 0$ $CP_{S1.2\ 14} = 0$	$CP_{S2.1\ 14} = P1$ $CP_{S2.1\ 15} = P3$ $CP_{S2.1\ 16} = P3$ $CP_{S2.2\ 11} = P3$ $CP_{S2.2\ 12} = 0$ $CP_{S2.3\ 13} = P1$	$CP_{S3.1\ 15} = 0$ $CP_{S3.1\ 16} = 0$ $CP_{S3.2\ 11} = 0$ $CP_{S3.2\ 17} = 0$

**Source:** Author

(page intentionally left in blank)

## Appendix 3. Performance Indicators

### Information available

**Table 151:** System elements available in a system

<b>Indicator name</b>	<b>Number of system elements available in a system (<math>IRA_s</math>)</b>
<b>Informal definition</b>	Number of system elements available in a system
<b>Formal definition</b>	$\forall s \in S,$ $IRA_s =  RA_s $
<b>Range</b>	$\mathbb{N}_0$
<b>Scale</b>	Ratio
<b>Example</b>	$IRA_{S1.1} = 2; IRA_{S1.2} = 3;$ $IRA_{S2.1} = 3, IRA_{S2.2} = 2, IRA_{S2.3} = 1,$ $IRA_{S3.1} = 2, IRA_{S3.2} = 2$

**Source:** Author

## Information required

**Table 152:** System elements required by a system

<b>Indicator name</b>	<b>Number of system elements required by a system (<math>IRR_s</math>)</b>
<i>Informal definition</i>	Number of all system elements that implement CIM elements required by the participant
<i>Formal definition</i>	$\forall s \in S,$ $IRR_s =  RR_s $
<i>Range</i>	$\mathbb{N}_0$
<i>Scale</i>	Ratio
<i>Example</i>	$IRR_{S1.1} = 0; IRR_{S1.2} = 2;$ $IRR_{S2.1} = 0, IRR_{S2.2} = 0, IRR_{S2.3} = 0,$ $IRR_{S3.1} = 2, IRR_{S3.2} = 2$

**Source:** Author

## Information mapped

### Information mapped for provisioning

**Table 153:** System elements mapped for provisioning by a system

<i>Indicator name</i>	<i>Number of system elements mapped for provisioning by a system (IRMP<sub>s</sub>)</i>
<i>Informal definition</i>	Number of system elements: - which transformations to provide the corresponding CIM elements have been defined
<i>Formal definition</i>	$\forall s \in S,$ $IRMP_s =   RMP_s  $
<i>Range</i>	$\mathbb{N}_0$
<i>Scale</i>	Ratio
<i>Example</i>	$IRMP_{S1.1} = 0; IRMP_{S1.2} = 1;$ $IRMP_{S2.1} = 0, IRMP_{S2.2} = 0, IRMP_{S3} = 0,$ $IRMP_{S3.1} = 0, IRMP_{S3.2} = 0$

**Source:** Author



## Information mapped for consumption

**Table 154:** System elements mapped for consumption by a system

<b>Indicator name</b>	<b>Number of system elements mapped for consumption by a system (<math>IRMC_s</math>)</b>
<b>Informal definition</b>	Number of system elements which mappings to consume the corresponding CIM elements have been defined
<b>Formal definition</b>	$\forall s \in S,$ $IRMC_s =  RMC_s $
<b>Range</b>	$\mathbb{N}_0$
<b>Scale</b>	Ratio
<b>Example</b>	$IRMC_{S1.1} = 0; IRMC_{S1.2} = 2;$ $IRMC_{S2.1} = 0, IRMC_{S2.2} = 0, IRMC_{S2.3} = 0,$ $IRMC_{S3.1} = 1, IRMC_{S3.2} = 1$

**Source:** Author

## Information to be provided

Information that could be provided (baseline)

**Table 155:** System elements that could be provided by a system

<i>Indicator name</i>	<i>Number of system elements that could be provided by a system (IRCP<sub>s</sub>)</i>
<i>Informal definition</i>	Number of system elements that implement CIM elements: - available (implemented) in the system; - available (implemented) in at least a system of another participant
<i>Formal definition</i>	$\forall s \in S,$ $IRCP_s =  RCP_s $
<i>Range</i>	$\mathbb{N}_0$
<i>Scale</i>	Ratio
<i>Example</i>	$IRCP_{S1.1} = 2; IRCP_{S1.2} = 3;$ $IRCP_{S2.1} = 3, IRCP_{S2.2} = 2, IRCP_{S2.3} = 1,$ $IRCP_{S3.1} = 2, IRCP_{S3.2} = 1$

**Source:** Author

## Information that should be provided (potential performance)

**Table 156:** System elements that should be provided by a system

<i>Indicator name</i>	<i>Number of system elements that should be provided by a system (IRSP<sub>s</sub>)</i>
<i>Informal definition</i>	Number of system elements that implement CIM elements: <ul style="list-style-type: none"> <li>- available (implemented) in the system;</li> <li>- available (implemented) in at least one system of another participant</li> <li>- required by the participants that already implement it in their systems</li> </ul>
<i>Formal definition</i>	$\forall s \in S,$ $IRSP_s =  RSP_s $
<i>Range</i>	$\mathbb{N}_0$
<i>Scale</i>	Ratio
<i>Example</i>	$IRSP_{S1.1} = 1; IRSP_{S1.2} = 1;$ $IRSP_{S2.1} = 3, IRSP_{S2.2} = 1, IRSP_{S2.3} = 1,$ $IRSP_{S3.1} = 0, IRSP_{S3.2} = 0$

**Source:** Author

Information that must be provided (actual performance)

**Table 157:** System elements that must be provided by a system

<i>Indicator name</i>	<i>Number of system elements that must be provided by a system (IRHP<sub>s</sub>)</i>
<i>Informal definition</i>	Number of system elements implementing CIM elements: <ul style="list-style-type: none"> <li>- available (implemented) in the system;</li> <li>- available (implemented) in at least one system of another participant</li> <li>- required by the participants that already implement it in their systems</li> <li>- which transformations to provide them have been defined</li> </ul>
<i>Formal definition</i>	$\forall s \in S,$ $IRHP_s =   RHP_s  $
<i>Range</i>	$\mathbb{N}_0$
<i>Scale</i>	Ratio
<i>Example</i>	$IRHP_{S1.1} = 0; IRHP_{S1.2} = 1;$ $IRHP_{S2.1} = 0, IRHP_{S2.2} = 0, IRHP_{S2.3} = 0,$ $IRHP_{S3.1} = 0, IRHP_{S3.2} = 0$

**Source:** Author

## Information to be consumed

Information that could be consumed (baseline)

**Table 158:** System elements that could consume from other systems

<i>Indicator name</i>	<i>Number of systems elements that could consume from other systems (IRCC<sub>s</sub>)</i>
<i>Informal definition</i>	Number of system elements implementing CIM elements: - available in the system  - available in at least a system of another participant
<i>Formal definition</i>	$\forall s \in S,$ $IRCC_s =  RCC_s $
<i>Range</i>	$\mathbb{N}_0$
<i>Scale</i>	Ratio
<i>Example</i>	$IRCC_{S1.1} = 2; IRCC_{S1.2} = 3;$  $IRCC_{S2.1} = 3, IRCC_{S2.2} = 2, IRCC_{S2.3} = 1,$  $IRCC_{S3.1} = 2, IRCC_{S3.2} = 1$

**Source:** Author

Information that should be consumed (potential performance)

**Table 159:** System elements that should consume from other systems

<b>Indicator name</b>	<b>Number of system elements that should consume from other systems (<i>IRSC<sub>s</sub></i>)</b>
<i>Informal definition</i>	Number of system elements implementing CIM elements: - available in the system - available in at least a system of another participant - required by the participant
<i>Formal definition</i>	$\forall s \in S$ $IRSC_s =  RSC_s $
<i>Range</i>	$\mathbb{N}_0$
<i>Scale</i>	Ratio
<i>Example</i>	$IRSC_{S1.1} = 0; IRSC_{S1.2} = 2;$ $IRSC_{S2.1} = 0, IRSC_{S2.2} = 0, IRSC_{S2.3} = 0,$ $IRSC_{S3.1} = 2, IRSC_{S3.2} = 1$

**Source:** Author

## Information that must be consumed (actual performance)

**Table 160:** System elements that must consume from other systems

<i>Indicator name</i>	<i>Number of systems elements that must consume from other systems (IRHC<sub>s</sub>)</i>
<i>Informal definition</i>	Number of system elements implementing CIM elements: <ul style="list-style-type: none"> <li>- available in the system</li> <li>- available in at least a system of another participant</li> <li>- required by the participant</li> <li>- which transformations to be consumed from the CIM have been defined</li> </ul>
<i>Formal definition</i>	$\forall s \in S$ $IRHC_s =  RHC_s $
<i>Range</i>	$\mathbb{N}_0$
<i>Scale</i>	Ratio
<i>Example</i>	$IRHC_{S1.1} = 0; IRHC_{S1.2} = 2;$ $IRHC_{S2.1} = 0, IRHC_{S2.2} = 0, IRHC_{S2.3} = 0,$ $IRHC_{S3.1} = 1, IRHC_{S3.2} = 1$

**Source:** Author

## Appendix 4. Relevance Indicators

### Information available

**Table 161:** Relevance of a system based on the information available

<i>Indicator name</i>	<i>Relevance of a system based on the information available (IRIA<sub>s</sub>)</i>
<i>Informal definition</i>	Sum of the weighted relevance of each of the system elements that are available in the system
<i>Formal definition</i>	$\forall s \in S, \forall a \in RAs, \forall i \in \mathbb{N}$ $IRIA_s = \sum_{i=1}^{ RAs } WR_{ai}$
<i>Range</i>	$\mathbb{R}$
<i>Scale</i>	Ratio
<i>Example</i>	$IRIA_{S1.1} = 5.60; IRIA_{S1.2} = 5.90$ $IRIA_{S2.1} = 6.40; IRIA_{S2.2} = 5.60; IRIA_{S2.3} = 1.30$ $IRIA_{S3.1} = 5.10; IRIA_{S3.2} = 5.60$

**Source:** Author



## Information required

**Table 162:** Relevance of a system based on the information required

<i>Indicator name</i>	<i>Relevance of a system based on the information required (IRIR<sub>s</sub>)</i>
<i>Informal definition</i>	Sum of the weighted relevance of each of the system elements which corresponding CIM elements are required by the participant
<i>Formal definition</i>	$\forall s \in S, \forall a \in RR_s, \forall i \in \mathbb{N}$ $IRIR_s = \sum_{i=1}^{ RR_s } WR_{ai}$
<i>Range</i>	$\mathbb{R}$
<i>Scale</i>	Ratio
<i>Example</i>	$IRIR_{S1.1} = 0; IRIR_{S1.2} = 2.60$ $IRIR_{S2.1} = 0; IRIR_{S2.2} = 0; IRIR_{S2.3} = 0$ $IRIR_{S3.1} = 5.10; IRIR_{S3.2} = 5.60$

**Source:** Author

## Information mapped

### Information mapped for provisioning

**Table 163:** Relevance of a system based on the information mapped for provisioning

<i>Indicator name</i>	<i>Relevance of a system based on the information mapped for provisioning (IRFP<sub>s</sub>)</i>
<i>Informal definition</i>	Sum of the weighted relevance of each of the system elements that are mapped for provisioning
<i>Formal definition</i>	$\forall s \in S, \forall a \in RMP_s, \forall i \in \mathbb{N}$ $IRFP_s = \sum_{i=1}^{ RMP_s } WR_{ai}$
<i>Range</i>	$\mathbb{R}$
<i>Scale</i>	Ratio
<i>Example</i>	$IRFP_{S1.1} = 0; IRFP_{S1.2} = 3.30$ $IRFP_{S2.1} = 0; IRFP_{S2.2} = 0; IRFP_{S2.3} = 0$ $IRFP_{S3.1} = 0; IRFP_{S3.2} = 0$

**Source:** Author

## Information mapped for consumption

**Table 164:** Relevance of a system based on the information mapped for consumption

<b>Indicator name</b>	<b>Relevance of a system based on the information mapped for consumption (IRFC<sub>s</sub>)</b>
<i>Informal definition</i>	Sum of the weighted relevance of each of the system elements that are mapped for consumption
<i>Formal definition</i>	$\forall s \in S, \forall a \in RMC_s, \forall i \in \mathbb{N}$ $IRFC_s = \sum_{i=1}^{ RMC_s } WR_{ai}$
<i>Range</i>	$\mathbb{R}$
<i>Scale</i>	Ratio
<i>Example</i>	$IRFC_{S1.1} = 0; IRFC_{S1.2} = 2.60$ $IRFC_{S2.1} = 0; IRFC_{S2.2} = 0; IRFC_{S2.3} = 0$ $IRFC_{S3.1} = 3.30; IRFC_{S3.2} = 3.30$

**Source:** Author

## Information to be provided

Information that should be provided

**Table 165:** Potential relevance of a system as a provider of information

<i>Indicator name</i>	<i>Potential relevance of a system as a provider of information (IPRP<sub>s</sub>)</i>
<i>Informal definition</i>	Sum of the weighted relevance of each of the system elements that should be provided by the system
<i>Formal definition</i>	$\forall s \in S, \forall a \in RSP_s, \forall i \in \mathbb{N}$ $IPRP_s = \sum_{i=1}^{ RSP_s } WR_{ai}$
<i>Range</i>	$\mathbb{R}$
<i>Scale</i>	Ratio
<i>Example</i>	$IPRP_{S1.1} = 3.30; IPRP_{S1.2} = 3.30$ $IPRP_{S2.1} = 6.40; IPRP_{S2.2} = 3.30; IPRP_{S2.3} = 1.30$ $IPRP_{S3.1} = 0; IPRP_{S3.2} = 0$

**Source:** Author

## Information that must be provided

**Table 166:** Actual relevance of a system as a provider of information

<b>Indicator name</b>	<b>Actual relevance of a system as a provider of information (<math>IARP_s</math>)</b>
<b>Informal definition</b>	Sum of the weighted relevance of each of the system elements that must be provided by the system
<b>Formal definition</b>	$\forall s \in S, \forall a \in RHP_s, \forall i \in \mathbb{N}$ $IARP_s = \sum_{i=1}^{ RHP_s } WR_{ai}$
<b>Range</b>	$\mathbb{N}_0$
<b>Scale</b>	Ratio
<b>Example</b>	$IARP_{S1.1} = 0; IARP_{S1.2} = 3.30$ $IARP_{S2.1} = 0; IARP_{S2.2} = 0; IARP_{S2.3} = 0$ $IARP_{S3.1} = 0; IARP_{S3.2} = 0$

**Source:** Author

## Information to be consumed

Information that should be consumed

**Table 167:** Potential relevance of a system as a consumer of information

<i>Indicator name</i>	<i>Potential relevance of a system as a consumer of information (IPRC<sub>s</sub>)</i>
<i>Informal definition</i>	Sum of the weighted relevance of each of the system elements that should consume from the CIM
<i>Formal definition</i>	$\forall s \in S, \forall a \in RSCs, \forall i \in \mathbb{N}$ $IPRC_s = \sum_{i=1}^{ RSC_s } WR_{ai}$
<i>Range</i>	$\mathbb{N}_0$
<i>Scale</i>	Ratio
<i>Example</i>	$IPRC_{S1.1} = 0; IPRC_{S1.2} = 2.60$ $IPRC_{S2.1} = 0; IPRC_{S2.2} = 0; IPRC_{S2.3} = 0$ $IPRC_{S3.1} = 5.10; IPRC_{S3.2} = 3.30$

**Source:** Author

## Information that must be consumed

**Table 168:** Actual relevance of a system as a consumer of information

<b>Indicator name</b>	<b>Actual relevance of a system as a consumer of information (<math>IARC_s</math>)</b>
<i>Informal definition</i>	Sum of the weighted relevance of each of the system elements that must consume from the CIM
<i>Formal definition</i>	$\forall s \in S, \forall a \in RHCs, \forall i \in \mathbb{N}$ $IARC_s = \sum_{i=1}^{ RHC_s } WR_{ai}$
<i>Range</i>	$\mathbb{N}_0$
<i>Scale</i>	Ratio
<i>Example</i>	$IARC_{S1.1} = 0; IARC_{S1.2} = 2.60$ $IARC_{S2.1} = 0; IARC_{S2.2} = 0; IARC_{S2.3} = 0$ $IARC_{S3.1} = 3.30; IARC_{S3.2} = 3.30$

**Source:** Author

## Appendix 5. Assessment of the scenario

### Parameters

In the following table we can see the parameters and additional calculations necessary to instantiate the iShare indicators with the information sharing scenario. For each CIM element (I1 to I7) we will find the relevance assigned for each of the factors considered (F1 to F3), and also the overall relevance, calculated based on the relative weights assigned to each of the risks.

**Table 169:** Scenario parameters and additional calculations

**Source:** Author

CIM element	F1	F2	F3	Overall relevance
I1	4	3	2	3,3
I2	3	2	1	2,3
I3	2	1	0	1,3
I4	1	0	4	1,3
I5	0	4	3	1,8
I6	4	3	2	3,3
I7	3	2	1	2,3
Factor	Weight			
F1	0,5			
F2	0,3			
F3	0,2			

### Systems performance and relevance

In the following table we can see the number of instances of CIM information elements, for each representation target and for each system. We can also see the calculation of the corresponding indicators of performance and relevance, where the latter take into consideration the relevance of the CIM elements calculated in the previous table.



**Table 170: Scenario concepts and indicators**

Source: Author

		I1	I2	I3	I4	I5	I6	I7	Performance	Relevance
RA	S1.1	1	1	0	0	0	0	0	2,00	5,60
	S1.2	1	0	1	1	0	0	0	3,00	5,90
	S2.1	0	0	0	1	1	1	0	3,00	6,40
	S2.2	1	1	0	0	0	0	0	2,00	5,60
	S2.3	0	0	1	0	0	0	0	1,00	1,30
	S3.1	0	0	0	0	1	1	0	2,00	5,10
	S3.2	1	0	0	0	0	0	1	1,00	5,60
RR	S1.1	0	0	0	0	0	0	0	0,00	0,00
	S1.2	0	0	1	1	0	0	0	2,00	2,60
	S2.1	0	0	0	0	0	0	0	0,00	0,00
	S2.2	0	0	0	0	0	0	0	0,00	0,00
	S2.3	0	0	0	0	0	0	0	0,00	0,00
	S3.1	0	0	0	0	1	1	0	2,00	5,10
	S3.2	0	0	0	0	0	0	0	0,00	0,00

## **Dashboard example**

In the following figures we can see an example of what could constitute a possible dashboard for managing semantic interoperability activities. In the first figure we can see the different systems positioned in a reference system determined by the relevance and performance. Those systems positioned in the top right corner have the best semantic interoperability situation, hence are the ones where less improvement can be expected. In the opposite corner we can find the systems in the opposite situation. That is, the systems with lower performance and with lower relevance, hence the ones from which we can expect major improvements. In the second figure we can see the performance of each system as a provider, and also as a consumer, considering the potential and actual performance. Finally, in the third figure we can see the relevance of each system as a provider, and also as a consumer, considering the potential and actual relevance. These last two figures provide the detail of what is depicted in the first figure, thus enabling a more detailed analysis of the situation. These three figures could be used, together, to build a dashboard to manage semantic interoperability of various organizations. Naturally, each situation is different, and some more charts could be added, with more or less detail and even with different indicators, according to the needs.

**Figure 58:** Systems relative performance and relevance

Source: Author

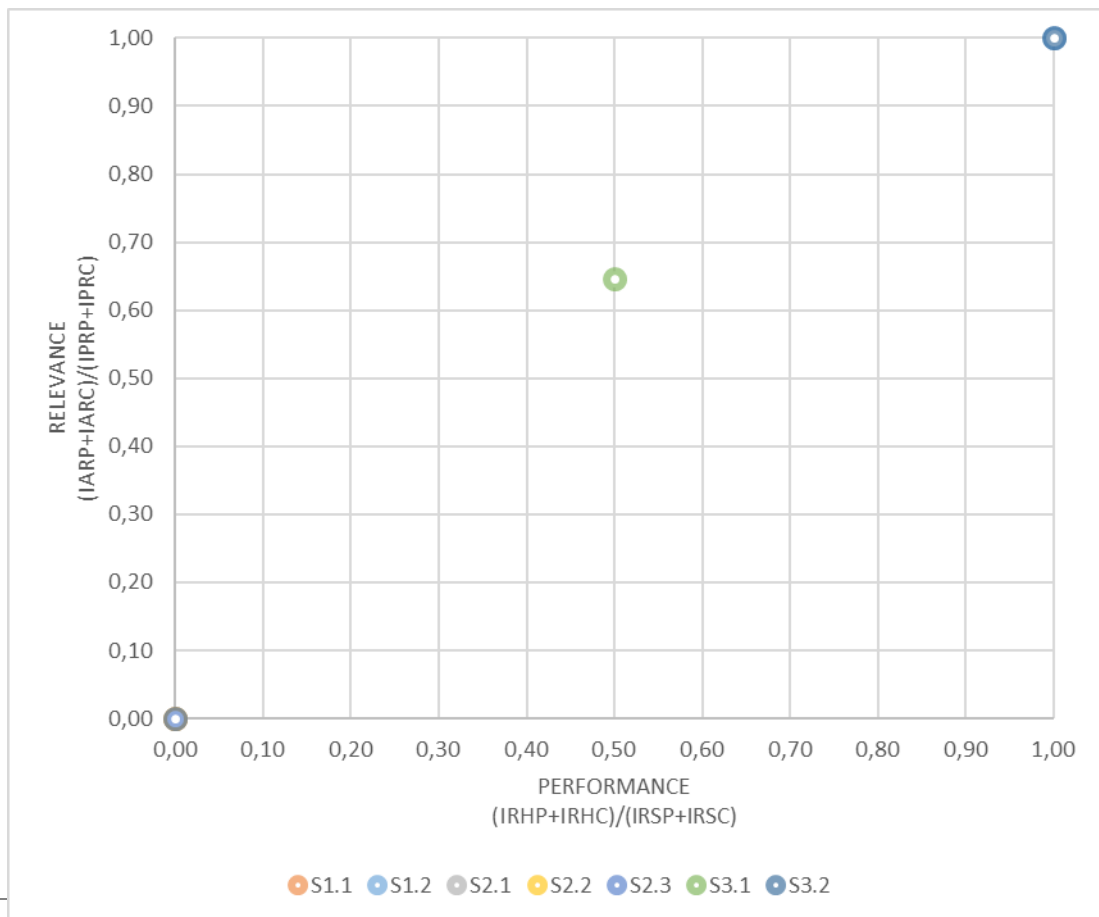

**Figure 59:** Systems performance as provider and consumer

**Source:** Author

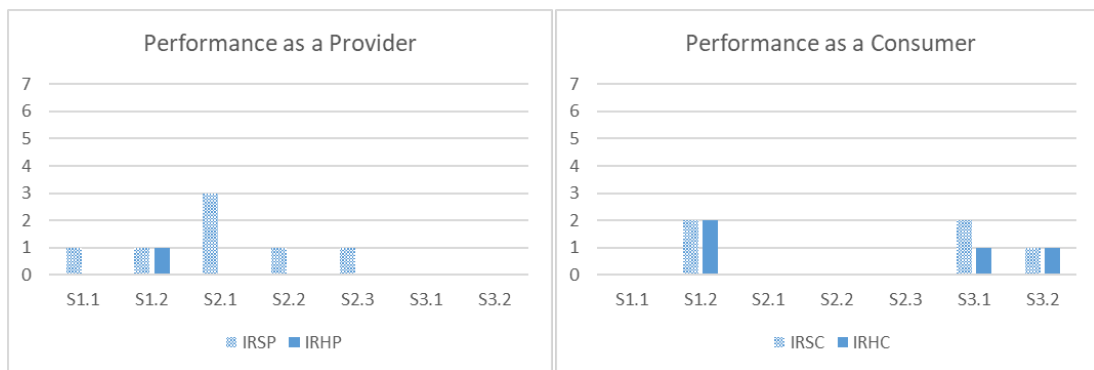

**Figure 60:** Systems relevance as provider and consumer

Source: Author

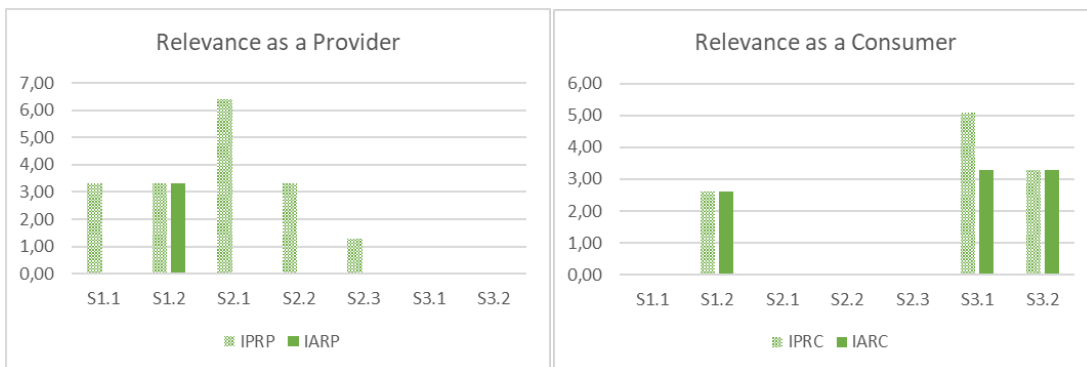

## Appendix 6. Questionnaire submitted (digital version also)

In this appendix we can see some screenshots of the questionnaire submitted. Since the third part of the questionnaire is very long, we provide only a snapshot of it here, and the full document is available in digital format also.



## Part I - Introduction

Guardar Automáticamente  | Questionnaire - Guardado | Sérgio Bytton | Partilhar

Ficheiro Base Inserir Esquema de Página Fórmulas Dados Reverter Ver Digitar-me o que pretende fazer

	A	B	C	D	E	F	G	H	I	J	K	L
C22												
1												
2												
3												
4												
5												
6												
7												
8												
9												
10												
11												
12												
13												
14												
15												
16												
17												
18												
19												
20												
21												
22												
23												
24												
25												
26												
27												

Pronto

Introduction | Instructions | Questions



## Part II - Instructions

Guardar Automáticamente
Questionnaire - Guardado
Sérgio Bryton
Partilhar

Ficheiro
Base
Inserir
Esquema de Página
Fórmulas
Dados
Rever
Ver
Diga-me o que pretende fazer

L17	A	B	C	D	E	F	G	H	I	J	K	L	M	N	O	P	Q	R	S	T	U	V	W	
1																								
2																								
3																								
4																								
5																								
6																								
7																								
8																								
9																								
10																								
11																								
12																								
13																								
14																								
15																								
16																								
17																								
18																								
19																								
20																								
21																								
22																								
23																								
24																								

Pronto
Introduction
Instructions
Questions

### Part III - Questions

Questionnaire - Guardado Sérgio Bryton

Guardar Automáticamente Esquema de Página Fórmulas DADOS Reverter Ver Diga-me o que pretende fazer Partilhar

Ficheiro Base Inserir

Q23

	A	B	C	D	E	F	G	H	I	J	K	L	M	N	O	P
		ATTRIBUTE_NAME	REQUIRED	S1	S2	S3	S4	S5	S6	R1	R2	R3	R4	R5	R6	R7
1	ENTITY_NAME															
2	Aircraft	Color														
3	Aircraft	ExternalMarkings														
4	Aircraft	MaximumSpeed														
5	Aircraft	Metadata														
6	Aircraft	Name														
7	Aircraft	Nationality														
8	Aircraft	TotalPersonsOnBoard														
9	LandVehicle	Color														
10	LandVehicle	ExternalMarkings														
11	LandVehicle	MaximumSpeed														
12	LandVehicle	Metadata														
13	LandVehicle	Name														
14	LandVehicle	Nationality														
15	LandVehicle	TotalPersonsOnBoard														
16	Vessel	IMONumber														
17	Vessel	MMSI														
18	Vessel	CallSign														
19	Vessel	NavigationalStatus														
20	Vessel	RegistryDate														
21	Vessel	RegistryNumber														
22	Vessel	INMARSATNumber														
23	Vessel	GrossTonnage														

Pronto

Introduction Instructions Questions

## **Appendix 7. Software application (digital version only)**

This appendix is relative to the software application developed to perform calculations supporting the determination of the core concepts. The corresponding listing is available in digital format only.

(page intentionally left in blank)

## **Appendix 8. Scenario original data (digital version also)**

In the following table, we depict the information presented in appendix 1. This table reflects the structure of the .csv file that was used by the software application to calculate the core concepts, as well as the performance and relevance indicators of the information exchange scenario.

In the first two columns, we can find information relative to the information element. Namely, in the first column we can see the organization that has it, and in the second column we can see the name of the information element. Then, in the third column we can see if the organization requires (Y) that information element or not. In the following six columns, we can see if the information element is available (Y) in one or more of the six possible systems (S1 to S6). Then, in the following six columns, we can see if the information element is mapped for consumption (Y), and in which system (S1 to S6). And in the following six columns we can see if the information element is mapped for provisioning (Y) and in which system (S1 to S6). Finally, in the last three columns, we can see the relevance of the information element for each risk (R1 to R3), expressed in a scale from 0 to 4.

**Table 171:** Scenario original data

ORG	ELEMENT	REQUI RED	A-S1	A-S2	A-S3	A-S4	A-S5	A-S6	MFC-S1	MFC-S2	MFC-S3	MFC-S4	MFC-S5	MFC-S6	MFP-S1	MFP-S2	MFP-S3	MFP-S4	MFP-S5	MFP-S6	R1	R2	R3
1	I1		Y	Y												Y					0	1	2
1	I2		Y																		3	4	1
1	I3	Y		Y						Y											2	1	0
1	I4	Y		Y						Y											4	3	0
1	I5	Y																			4	2	1
1	I6																				3	1	2
1	I7	Y																			4	2	0
2	I1			Y																	0	1	2
2	I2			Y																	1	2	3
2	I3				Y																3	4	1
2	I4		Y																		1	2	3
2	I5		Y																		0	1	2
2	I6		Y																		1	4	3
2	I7																				2	3	2
3	I1	Y		Y						Y											3	3	3
3	I2	Y																			4	4	4
3	I3	Y																			1	1	1
3	I4	Y																			0	0	1
3	I5	Y	Y																		2	1	3
3	I6	Y	Y						Y												0	0	0
3	I7	Y		Y																	1	2	3

Source: Author

## Appendix 9. Scenario calculated data (digital version also)

In the following table, we depict the results of the software application after having processed the file with the scenario data presented in appendix 8 (scenario original data). This table reflects the structure of the .csv file produced and its digital version is also available.

In the first column we can see the CIM element. In the second column the system where the CIM element is implemented. In the third column we can see the participant to which the system belongs. In the next column we can see the system element that implements the CIM element in the system mentioned. In the fifth column we can see to which representation target this information belongs. In the following three columns we can see the average relevance (0 to 4) of the information element to each of the three risks (RF1 to RF3), considering the opinion of each organization, as described in appendix 5. Finally, in the last column, we can see the relevance of the information element calculated based on the relative weights of each risk, considering also the information provided in appendix 5.

**Table 172:** Scenario calculated data

CIM Element	System	Participant	System Element	Rep. Target	RF1	RF2	RF3	Relevance
I1	S1.1	P1	S1.1_I1	RA	1	1,666667	2,333333	0,366667
I2	S1.1	P1	S1.1_I2	RA	2,666667	3,333333	2,666667	0,716667
I1	S1.1	P1	S1.1_I1	RCP	1	1,666667	2,333333	0,366667
I2	S1.1	P1	S1.1_I2	RCP	2,666667	3,333333	2,666667	0,716667
I1	S1.1	P1	S1.1_I1	RSP	1	1,666667	2,333333	0,366667
I1	S1.1	P1	S1.1_I1	RCC	1	1,666667	2,333333	0,366667
I2	S1.1	P1	S1.1_I2	RCC	2,666667	3,333333	2,666667	0,716667
I1	S1.2	P1	S1.2_I1	RA	1	1,666667	2,333333	0,366667
I3	S1.2	P1	S1.2_I3	RA	2	2	0,666667	0,433333
I4	S1.2	P1	S1.2_I4	RA	1,666667	1,666667	1,333333	0,4
I3	S1.2	P1	S1.2_I3	RR	2	2	0,666667	0,433333
I4	S1.2	P1	S1.2_I4	RR	1,666667	1,666667	1,333333	0,4
I3	S1.2	P1	S1.2_I3	RMC	2	2	0,666667	0,433333
I4	S1.2	P1	S1.2_I4	RMC	1,666667	1,666667	1,333333	0,4
I1	S1.2	P1	S1.2_I1	RMP	1	1,666667	2,333333	0,366667
I1	S1.2	P1	S1.2_I1	RCP	1	1,666667	2,333333	0,366667
I3	S1.2	P1	S1.2_I3	RCP	2	2	0,666667	0,433333
I4	S1.2	P1	S1.2_I4	RCP	1,666667	1,666667	1,333333	0,4
I1	S1.2	P1	S1.2_I1	RSP	1	1,666667	2,333333	0,366667
I1	S1.2	P1	S1.2_I1	RHP	1	1,666667	2,333333	0,366667
I1	S1.2	P1	S1.2_I1	RCC	1	1,666667	2,333333	0,366667
I3	S1.2	P1	S1.2_I3	RCC	2	2	0,666667	0,433333
I4	S1.2	P1	S1.2_I4	RCC	1,666667	1,666667	1,333333	0,4
I3	S1.2	P1	S1.2_I3	RSC	2	2	0,666667	0,433333
I4	S1.2	P1	S1.2_I4	RSC	1,666667	1,666667	1,333333	0,4
I3	S1.2	P1	S1.2_I3	RHC	2	2	0,666667	0,433333
I4	S1.2	P1	S1.2_I4	RHC	1,666667	1,666667	1,333333	0,4

CIM Element	System	Participant	System Element	Rep. Target	RF1	RF2	RF3	Relevance
I4	S2.1	P2	S2.1_I4	RA	1,666667	1,666667	1,333333	0,4
I5	S2.1	P2	S2.1_I5	RA	2	1,333333	2	0,45
I6	S2.1	P2	S2.1_I6	RA	1,333333	1,666667	1,666667	0,375
I4	S2.1	P2	S2.1_I4	RCP	1,666667	1,666667	1,333333	0,4
I5	S2.1	P2	S2.1_I5	RCP	2	1,333333	2	0,45
I6	S2.1	P2	S2.1_I6	RCP	1,333333	1,666667	1,666667	0,375
I4	S2.1	P2	S2.1_I4	RSP	1,666667	1,666667	1,333333	0,4
I5	S2.1	P2	S2.1_I5	RSP	2	1,333333	2	0,45
I6	S2.1	P2	S2.1_I6	RSP	1,333333	1,666667	1,666667	0,375
I4	S2.1	P2	S2.1_I4	RCC	1,666667	1,666667	1,333333	0,4
I5	S2.1	P2	S2.1_I5	RCC	2	1,333333	2	0,45
I6	S2.1	P2	S2.1_I6	RCC	1,333333	1,666667	1,666667	0,375
I1	S2.2	P2	S2.2_I1	RA	1	1,666667	2,333333	0,366667
I2	S2.2	P2	S2.2_I2	RA	2,666667	3,333333	2,666667	0,716667
I1	S2.2	P2	S2.2_I1	RCP	1	1,666667	2,333333	0,366667
I2	S2.2	P2	S2.2_I2	RCP	2,666667	3,333333	2,666667	0,716667
I1	S2.2	P2	S2.2_I1	RSP	1	1,666667	2,333333	0,366667
I1	S2.2	P2	S2.2_I1	RCC	1	1,666667	2,333333	0,366667
I2	S2.2	P2	S2.2_I2	RCC	2,666667	3,333333	2,666667	0,716667
I3	S2.3	P2	S2.3_I3	RA	2	2	0,666667	0,433333
I3	S2.3	P2	S2.3_I3	RCP	2	2	0,666667	0,433333
I3	S2.3	P2	S2.3_I3	RSP	2	2	0,666667	0,433333
I3	S2.3	P2	S2.3_I3	RCC	2	2	0,666667	0,433333
I5	S3.1	P3	S3.1_I5	RA	2	1,333333	2	0,45
I6	S3.1	P3	S3.1_I6	RA	1,333333	1,666667	1,666667	0,375
I5	S3.1	P3	S3.1_I5	RR	2	1,333333	2	0,45
I6	S3.1	P3	S3.1_I6	RR	1,333333	1,666667	1,666667	0,375
I6	S3.1	P3	S3.1_I6	RMC	1,333333	1,666667	1,666667	0,375
I5	S3.1	P3	S3.1_I5	RCP	2	1,333333	2	0,45
I6	S3.1	P3	S3.1_I6	RCP	1,333333	1,666667	1,666667	0,375
I5	S3.1	P3	S3.1_I5	RCC	2	1,333333	2	0,45
I6	S3.1	P3	S3.1_I6	RCC	1,333333	1,666667	1,666667	0,375
I5	S3.1	P3	S3.1_I5	RSC	2	1,333333	2	0,45
I6	S3.1	P3	S3.1_I6	RSC	1,333333	1,666667	1,666667	0,375
I6	S3.1	P3	S3.1_I6	RHC	1,333333	1,666667	1,666667	0,375
I1	S3.2	P3	S3.2_I1	RA	1	1,666667	2,333333	0,366667
I7	S3.2	P3	S3.2_I7	RA	2,333333	2,333333	1,666667	0,55
I1	S3.2	P3	S3.2_I1	RR	1	1,666667	2,333333	0,366667
I7	S3.2	P3	S3.2_I7	RR	2,333333	2,333333	1,666667	0,55
I1	S3.2	P3	S3.2_I1	RMC	1	1,666667	2,333333	0,366667
I1	S3.2	P3	S3.2_I1	RCP	1	1,666667	2,333333	0,366667
I1	S3.2	P3	S3.2_I1	RCC	1	1,666667	2,333333	0,366667
I1	S3.2	P3	S3.2_I1	RSC	1	1,666667	2,333333	0,366667
I1	S3.2	P3	S3.2_I1	RHC	1	1,666667	2,333333	0,366667



## **Appendix 10. NIPIMAR original data (digital version only)**

In this appendix we can see the data that resulted from the questionnaires in the format provided to the software application. The format used is very similar to the one presented in appendix 8. The only difference lies on the number of columns dedicated to the risks, since in the scenario we considered only three risks, and in the real case we considered seven risks. Since it is a very large file, it is only available in digital format only.

(page intentionally left in blank)

## **Appendix 11. NIPIMAR calculated data (digital version only)**

In this appendix we can see the data that resulted from software application, after having processed the original NIPIMAR data as presented in appendix 10. Likewise, the format used is very similar to the one presented in appendix 9. The only difference lies on the number of columns dedicated to the risks, since in the scenario we considered only three risks, and in the real case we considered seven risks. Since it is a very large file, it is only available in digital format only.

(page intentionally left in blank)

## Appendix 12. Information to be exchanged (digital version only)

This appendix presents the list of system elements that should provide information (on the right column) to the systems elements that will consume information (on the left column). This information is essential to understand, which are the semantic interoperability actions that must be carried out, in the providers side, to complement the actions that will be carried out in the consumer side. Without taking this information into consideration, a project could implement only the actions on the consumer side and hence the information might not be able to be consumed, because the actions necessary to ensure that the information is also going to be provided were not carried out since they were not accounted for. This information was generated automatically with some scripts developed in (Standard Query Language) SQL based on the data generated by the inherent core concepts. Since the list with the results of this computation are very long, we are providing here only an example, whereas the full set of results can be found in the digital version of this appendix, which is attached to this document.

### Consumer

SA.1\_Vessel::Breadth

SA.1\_Vessel::Callsign

SA.1\_Vessel::ContainerCapacity

### Provider

SF.4\_Vessel::Breadth

SC.1\_Vessel::Callsign

SC.2\_Vessel::Callsign

SF.1\_Vessel::Callsign

SF.2\_Vessel::Callsign

SF.4\_Vessel::Callsign

SC.1\_Vessel::ContainerCapacity

SC.2\_Vessel::ContainerCapacity

(page intentionally left in blank)

## Appendix 13. Information elements per project (digital version only)

This appendix presents a list of the actions that must be implemented in each project, sorted in descending order by the relevance of the information element to be consumed. Firstly, we can see the project the action corresponds to. Secondly we can see the actions to be carried out in the consumer side, accompanied by its relevance. Lastly, we can see the corresponding actions to be carried out in the providers side, to ensure that, after the project, the information can be consumed, because semantic interoperability has been implemented in all intervenients. This list results from the reasoning presented in chapter 7 and was calculated automatically with a script defined in SQL based on the data resulting from the relevant core elements. Since the list with the results of this computation is very long, we are providing here only an example, whereas the full set of results can be found in the digital version of this appendix, which is attached to this document.

### Project 1

#### Consumer

SA.1\_Vessel::Callsign

0,808333333

SA.1\_Vessel::IMONumber

0,763125

#### Provider

SC.1\_Vessel::Callsign

SC.2\_Vessel::Callsign

SF.1\_Vessel::Callsign

SF.2\_Vessel::Callsign

SF.4\_Vessel::Callsign

SC.1\_Vessel::IMONumber

SC.2\_Vessel::IMONumber

SF.2\_Vessel::IMONumber

SF.4\_Vessel::IMONumber

(page intentionally left in blank)



## **Annexes**

(page intentionally left in blank)

## **Annex A. Permission for data and information access and usage**