

Kent Academic Repository

Full text document (pdf)

Citation for published version

Hillier, Aaron and Makarovaite, V. and Gourlay, Campbell W. and Holder, Simon J. and Batchelor, John C. (2019) A Passive UHF RFID Dielectric Sensor for Aqueous Electrolytes. *IEEE Sensors Journal*. pp. 1-7. ISSN 1530-437X.

DOI

<https://doi.org/10.1109/JSEN.2019.2909353>

Link to record in KAR

<https://kar.kent.ac.uk/73401/>

Document Version

Publisher pdf

Copyright & reuse

Content in the Kent Academic Repository is made available for research purposes. Unless otherwise stated all content is protected by copyright and in the absence of an open licence (eg Creative Commons), permissions for further reuse of content should be sought from the publisher, author or other copyright holder.

Versions of research

The version in the Kent Academic Repository may differ from the final published version.

Users are advised to check <http://kar.kent.ac.uk> for the status of the paper. **Users should always cite the published version of record.**

Enquiries

For any further enquiries regarding the licence status of this document, please contact:

researchsupport@kent.ac.uk

If you believe this document infringes copyright then please contact the KAR admin team with the take-down information provided at <http://kar.kent.ac.uk/contact.html>

A Passive UHF RFID Dielectric Sensor for Aqueous Electrolytes

Aaron J.R. Hillier, Viktorija Makarovaite, Campbell W. Gourlay, Simon J. Holder, John C. Batchelor, Senior Member, IEEE

Abstract— The one step modification of a commercial RFID sensing tag is demonstrated using polydimethylsiloxane based thin film chemistry to construct reusable passive RFID sensors for changes in the dielectric properties of electrolyte solutions as a function of concentration. The effects of PDMS film thickness were characterized as a function of RFID sensor code value. The output sensor code of the RFMicron RFM2100-AER wireless flexible moisture sensor (taken between 800-860 MHz) was compared to readings taken when the tag was dry and when the tag had a water deposition on the sensor area. The effect of the direct application of liquid water to the tag was to alter the capacitance presented to the integrated chip which auto-tunes to correct for the reactance. By varying the thickness of the PDMS film between the interdigitated sensor and deposited liquid, the sensitivity of the tag to a high dielectric medium could be controlled. Aqueous salt solutions were tested on a 500 μm thickness film. It was found that the sensing platform could be used as a means of measuring the concentration of various salt solutions within the range 0-2M, and in turn could be used as a passive UHF RFID dielectric measuring tool. The measurement capability of the platform was subsequently demonstrated using a reduced frequency range (845-865 MHz).

Index Terms— Radio Frequency Identification, RFID tags, chemical sensor, aqueous electrolyte.

I. INTRODUCTION

Wireless chemical sensors (WCSs) are an area of communications that have recently experienced a large increase in interest [1][2]. Chemical sensors are defined as a device that transforms chemical information [3] and possesses both a receptor (which transforms chemical information into energy) and a transducer (part capable of transforming the receptor energy into a useful analytical signal). The most common wireless platforms integrated into chemical sensors are Bluetooth (34%) [1] and Radio Frequency Identification (RFID) (23%) [2].

RFID is becoming an increasingly common method for identification [4] and anti-counterfeiting [5], being used increasingly for a wide range of applications (such as parcel and livestock tracking, theft prevention systems and contactless payment) [6]. One of the most rapidly growing applications of RFID has been its use for sensing purposes [2][7]. For example, in the agricultural industry, soil moisture and salinity monitoring is important for several reasons (profitability, efficiency, environmental health etc.) Soil moisture RFID tags have been proposed [8] for this purpose whereby a series of tags would be placed over a wide area in

order to monitor changes in moisture content of soil within specific locations. RFID applications for soil salinity sensing have also been investigated [9] where a monopole antenna sensor probe was designed to alter resonant frequency with changing soil moisture/salinity composition.

The monitoring of ions is the second most frequently researched analyte for wireless chemical sensors after pH [1]. One form of research has been for the monitoring of aqueous salts present in sweat and several systems have been developed that utilize different communication methods as well as transduction methods. Some of these designs have been bespoke systems such as the 'SWEATCH' [10], a wearable Bluetooth system that can detect Na^+ ions present in sweat. Other bespoke approaches have utilized RFID tags as adhesive wearables [11] that send potentiometric data relating to Na^+ concentration in sweat to a smartphone through Near field communication (NFC). An armband utilizing Bluetooth transmission was reported in [12] which can monitor sodium concentration in sweat. The primary transduction mechanism used in these devices is an ion selective potentiometer, and is often used for low concentration aqueous salt monitoring. Cheaper disposable alternatives for monitoring in the pharmaceutical industries manufacturing process have also been proposed as affordable, disposable sensors require single use manufacture [13].

Another approach taken with wireless chemical sensors is to modify pre-existing RFID tags and change the functionality by way of the addition of a chemically sensitive material. Variables that have been monitored using this approach have been food spoilage and ammonia concentration [14], gas sensing [15] and solvent vapour [16].

Until recently, sensing features within passive RFID have only been achievable by detuning the tag, adversely affecting read range and detecting the change in required tag turn-on power [17]. Some newer tags feature an integrated chip that is designed to tune their internal impedance[8][18] for the purpose of counteracting reactance changes caused by external stimuli. Whilst these systems provide a useful low cost means of sensing for a variety of stimuli (temperature, moisture, humidity etc.), they have limited sensitivity range, and because of their paper substrates, they are for single use once exposed to moisture[8].

Prior approaches to sensitizing RFID tags have involved incorporating sensing materials [19] but these are often purpose designed platforms for the particular material. Here,

using polydimethylsiloxane (PDMS) film deposition [20], we repurpose an existing commercial, low cost moisture sensing tag, allowing for the sensing of the change in dielectric constant of various liquids over multiple repetitions.

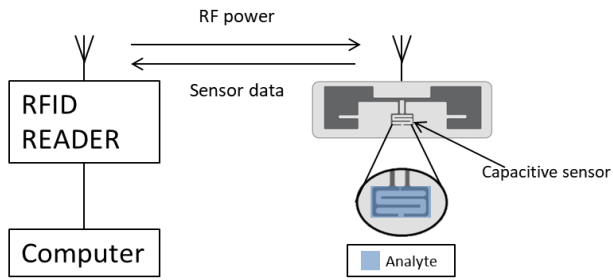

Fig. 1. Block diagram of a capacitive sensing system.

Fig.1. shows the general premise of the proposed system. An RFID reader communicates with the sensing tag, which in turn provides sensing information regarding the analyte atop the capacitive sensor. This information is then interpreted through software on a computer that is attached to the RFID reader.

II. SENSING TAG DESIGN

A. RF-Micron RFM2100-AER Tag

When a general RFID tag is placed in proximity to a dielectric material, the electromagnetic parameters of the substance interact with the tag antenna and cause a change in the antenna reactance. This would cause a conventional RFID tag to detune, adversely affecting the power transfer between the antenna and the transponder chip, and subsequently reducing

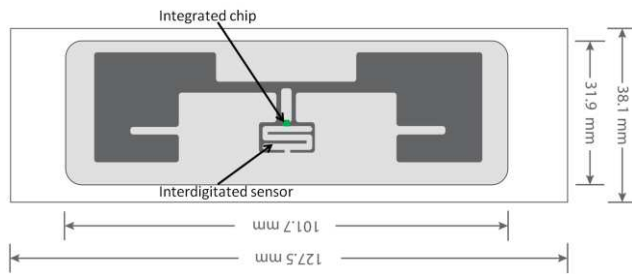

Fig. 2. Schematic diagram of the RFMicron RFM 2100-AER, with the interdigitated electrode indicated.

the read range. The RFM2100-AER RFMicron tag (AER variant is for the European bandwidth between 865.6 to 867.6 MHz, read range 4.8 m) transponder is able to tune the reactance at its port in order to compensate for a mismatch with the antenna [18]. Therefore, it is possible to regard the tag antenna and an associated electrode as a sensing transducer, where the variable reactance presented to the transponder is automatically compensated by tuning. This compensated reactance (i.e. the sensed parameter) is communicated digitally to the reader using the process described in [22]. The tuning mechanism within the transponder is facilitated by a switchable capacitor network, where the particular switching combination represents a 5 bit

sensor code. A schematic of the capacitor network is shown in Fig. 3.

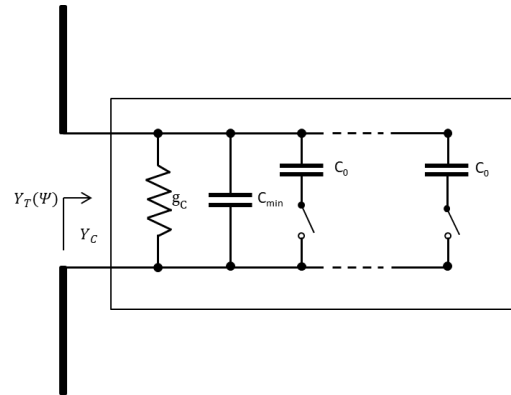

Fig. 3. Schematic diagram of the RFMicron RFM 2100-AER integrated chip

The advantage of using a digital sensor code method to communicate sensed level as opposed to the analog detuned backscattered power as reported in [7][8][9] is that the fluctuating wireless link parameters do not have to be calibrated out. Furthermore, the read range of the tag is not as compromised by detuning caused by the sensing process.

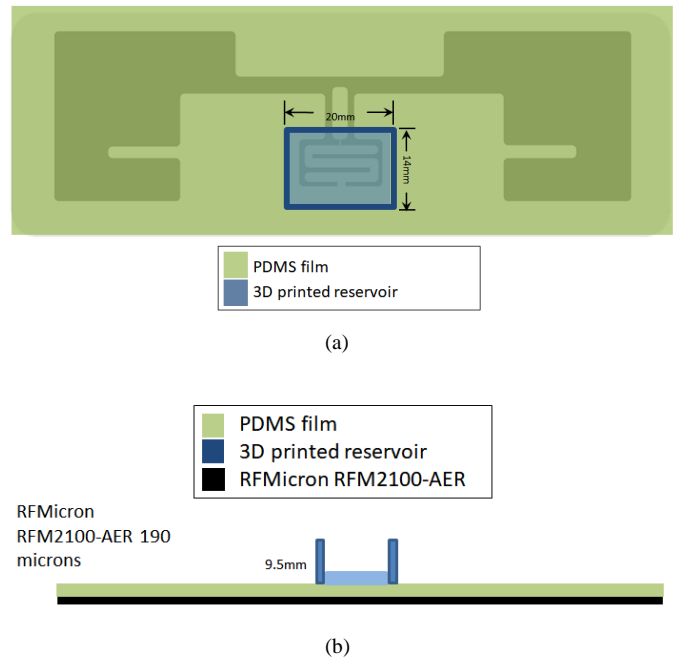

Fig. 4 (a) Schematic diagram of the RFMicron RFM-2100-AER, with the interdigitated electrode and liquid containing reservoir, and (b) Elevation view.

The tag used in this instance is the RFM2100-AER(RFMicron). The original application of the tag was as a wireless battery-free moisture sensor and the The tag (Fig. 2) has an interdigitated capacitor (IDC) sensing electrode.

The auto-tuning chip (Fig. 3.) switches its internal capacitance to maximize the delivered power, dependent on the material loaded onto the sensor electrode. The selected tuning state is transmitted as a ‘sensor code’ value to the

reader. The tag antenna conductor is aluminium, and the antenna substrate is paper.

B. Sensing Film and Deposition on Tag Electrodes

Silanol terminated PDMS (8 grams, 3.08×10^{-4} mol) was mixed with crosslinking agent tetraethoxysilane (0.13g, 6.24×10^{-4} mol) were speedmixed at 3500 rpm for 60 s. 0.18ml of catalyst tin 2-ethyl hexanoate was then added and speedmixed for a further 60 s at 3500 rpm. The mix was then poured onto the topside of the RFMicron tag. A doctor blade (Automatic precision film applicator MTCX4, mtv-messtechnik) was used (set to applicate at 500 μm) to distribute the fluid precursor over the entirety of the tag at the desired thickness. The deposited film was left overnight in a 65°C oven. Figs. 4 (a) and (b) show the coverage of the film as a schematic, from top facing and side facing views. PDMS was chosen as the protective insulating film due to its low dielectric constant (typically 2.2 to 2.8), facile processability, elastomeric nature which allows for flexibility on non-rigid tags, hydrophobicity, and relatively good chemical resistance.

III. RFMICRON SENSING PRINCIPLE

The RFMicron chip can vary its capacitance between 2-3pF dependent on the external stimulus or load material applied to the capacitive area. This has been previously expressed [21] [22] as:

$$C_T(n) = C_{min} + nC_0 \quad (1)$$

Where $C_T(n)$ refers to the total capacitance for the tag, C_{min} is the minimum capacitance that can be achieved by the microchip (which would be the capacitance that is achieved when there is no external reactance applied to the electrodes), n refers to the sensor code, and C_0 is a tunable step. This can be related to the presence of an external stimuli that causes the change also, as follows:

$$|B_C(n) + B_A(\Psi)| \rightarrow 0 \quad (2)$$

Where B_C is the susceptance of the chip, B_A is the susceptance of the antenna, and Ψ is an external stimulus from the environment. When the antenna susceptance is altered as a result, the capacitor array inside the chip compensates to negate the effect of the susceptance change. As such, n is a numerical expression of the degree of capacitive adjustment made by the chip. This means that the sensor code is directly related to the environmental variable being tested.

When modifying the tag, the association between sensor code and environmental response will inherently change.

Therefore, two things must be considered when performing any alteration to the antenna. Firstly, does the $\Psi:n$ association still persist post modification? Secondly, if the $\Psi:n$ association does persist, to what degree has the modification altered the association? A measurement methodology was established in order to confirm that the expected tag sensor

operation persisted after the PDMS film deposition.

A. Measurement Methodology

In each case the RFID reading was performed using Voyantic Tagformance equipment [23] between 800-860 MHz (with a step of 5 MHz), and a transmit power of 9 dBm. The distance between the reader and the tag for all measurements was calibrated to 30 cm. The reader was positioned underneath the tag so that the underside of the tag faced the reader and the maximum achievable read range was calculated by the reader.

All liquids under test were deposited from an auto-pipette into the reservoir mounted around the electrode. In all tests, 0.8 milliliters was applied to form a liquid layer of 0.5 mm thickness (the liquid deposition area can be seen in Figs. 4 (a) and (b)). After each measurement, the surface of the tag was dried, rinsed with deionized water, and then dried again. If the sensor response from the rinsed and dried tag was found to match that of the original dry value, then the next measurement could be performed. Measurements of aqueous salt solutions were taken in triplicate for each concentration.

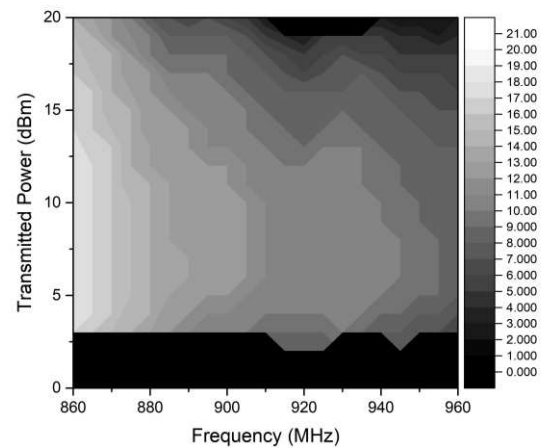

Fig. 5. Sensor code of an unmodified dry RFMicron 2100-AFR tag against frequency and transmitted power.

Fig. 5 shows that while the tag sensor value has a significant dependency on frequency, the variation with transmitted reader power is almost negligible. An average sensor value was calculated by taking the mean of all the values between 800-860 MHz for a fixed transmitted power of 9 dBm.

IV. FILM THICKNESS STUDIES

Adding bulk water directly to the electrodes of an unmodified tag with no PDMS film introduces a reactance so large that the chip is unable to tune out the impedance. That is, the unmodified tag is beyond its tuning capability. However, the hydrophobicity of a deposited thin PDMS film means that water does not permeate, but capacitive Electric fields are able to fringe through the film between the electrodes and the liquid. The separation of the liquid from the electrodes reduces the capacitive effect and brings the tag

within its tuning range. To ascertain the optimum performance in the presence of water solutions, it was necessary to test varying thicknesses of PDMS on the tag.

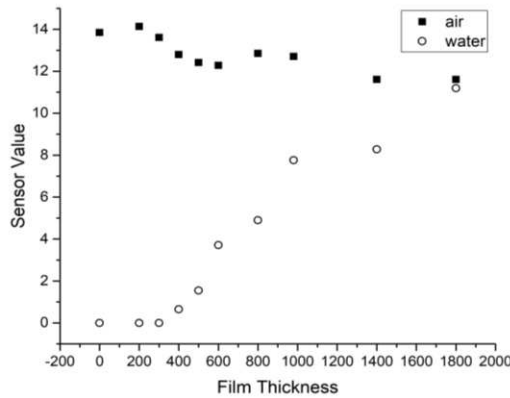

Fig. 6. The effect of increasing film thickness on sensor intensity when exposed to air and water

Fig. 6 shows averaged sensor values for tags with PDMS films applied with thicknesses ranging between 0 and 1800 μm . The tags were measured dry and with 0.8 mL of deionized water. It can be seen that for all tested film thicknesses, it was possible to discriminate between the dry and wetted tags, making bulk water sensing possible. The tag can therefore have its sensitivity tuned simply by modifying the thickness of the electrode coating film depending on the required application.. 500 μm was used as the film thickness for subsequent aqueous electrolyte monitoring as this thickness was thin enough to be more easily applied, whilst being thick enough to sufficiently isolate the capacitor from the analyte for sensing purposes. The effect of variable film thickness on aqueous electrolyte measurements is currently being investigated.

V. DIELECTRIC SOLUTION MEASUREMENTS

A. Aqueous electrolyte measurements

To determine the effect of varying the dielectric properties of the aqueous layer, a series of salt solutions of varying concentrations were applied to a tag with a 500 μm PDMS film. 10 mL stock solutions of NaCl, KCl, LiCl and RbCl in

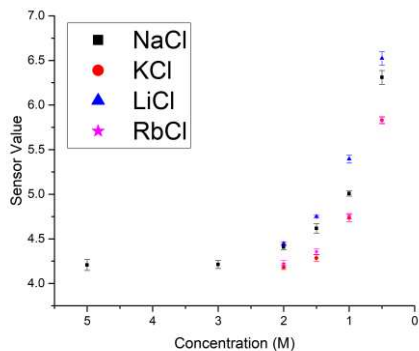

(a).

Fig. 7. (a) The effect of various concentration aqueous salt solutions on the averaged tag sensor value

de-ionized water were prepared at various concentrations between 0.25-5 M.

As shown in Fig. 7 (a), a concentration range between 0-2 M results in the largest change in sensor code value. According to expected values from [24][25], this corresponds

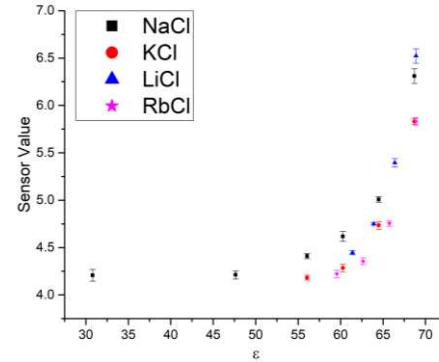

(b)

Fig. 7. (b) averaged sensor value against aqueous salt permittivity.

to a variation in relative permittivity of 65-55 for the test liquids as shown in Fig. 7 (b).

When the permittivity of the liquid is 55 or lower, the tag reaches the limit of its tuning range, and cannot distinguish between salt concentrations in excess of 2 M, (the concentration of NaCl in seawater is around 0.6 M [26]). Further investigation was needed to alter the concentration range over which the tag is sensitive.

B. NaCl Salt Concentration Measurements

After establishing that the sensor could be used to measure low/mid concentrations for multiple salts, NaCl measurements were taken between 0-2 M over a smaller incremental step of 0.1 M. Fig. 8 shows that as the concentration of the salt solution increases over 0.1 M, the averaged intensity lowers incrementally. The sigmoidal curve fit and resulting equation

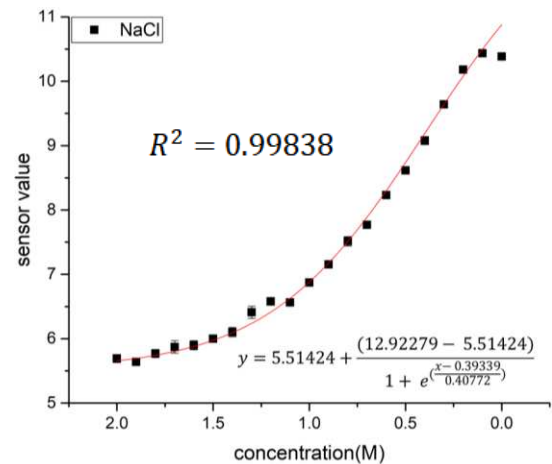

Fig. 8. The effect of NaCl salt solutions between 0 to 2 M on the tag averaged sensor code value.

were derived according to a Boltzmann distribution using the Levenberg Marquadt algorithm (this curve fitting and algorithm were also used to curves for Fig. 10 and Fig. 11).

To relate the measured sensor code to solution permittivity, Fig. 8 shows the NaCl data against Cole and Debye permittivity models [27], as well as measured values obtained from a Speag DAK 3.5 dielectric measurement probe attached to a Rohde & Schwarz ZXX Vector Network Analyzer. Good agreement is observed between the models and the measurement. Further, a correlation is also apparent between Fig. 7 and the NaCl data in Fig. 7 (b) showing the expected dielectric values from the literature.

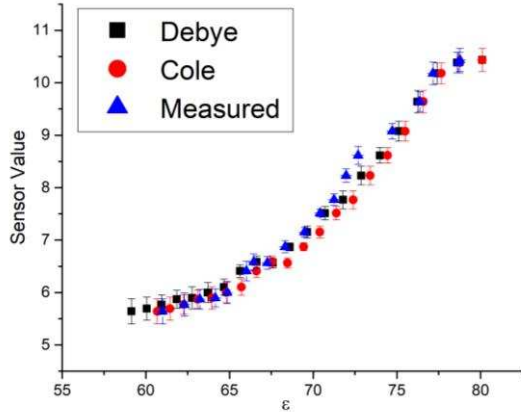

Fig. 9. Graph showing the effect of dielectric constant (for Cole & Debye and measured values) on the tag averaged sensor code.

For the concentrations shown in Fig. 9, below 0.1 M the averaged sensor code (permittivity) decreases in all models. At 0.1 M, NaCl solution shows slightly increased averaged sensor code values (permittivity) relative to water. Above this low concentration threshold, increasing the NaCl in the solution causes the permittivity to decrease. The measurements were performed in triplicate and found to be highly repeatable.

C. $\tan \delta$ comparison

Fig. 9 shows that whilst the relative permittivity of the solution is decreasing as concentration increases, the sensor values from the tag are decreasing. This is contrary to what should be seen when the relative permittivity of the analyte

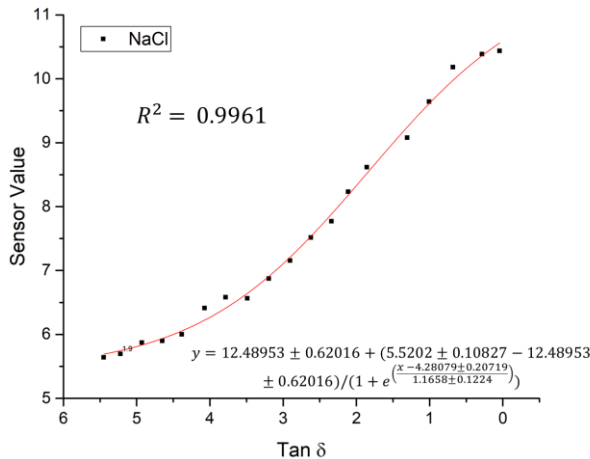

Fig. 10. Graph showing the effect of $\tan \delta$ on averaged sensor code values

decreases. The conductivity of NaCl solutions increases with increased concentration, thereby increasing the loss tangent $\tan \delta$ significantly. Fig. 10 shows that as the $\tan \delta$ increases for NaCl solutions, the sensor code averaged value reduces. The $\tan \delta$ is heavily dependent on both permittivity and conductivity, and is a more important variable to consider than solely permittivity. This is especially true of aqueous NaCl, where the solutions conductivity increases massively with increased concentration, which increases the $\tan \delta$ dramatically.

D. Sensor optimization

The sensor code values were originally averaged across 800-860 MHz. An investigation was made to assess the effect of reducing the swept frequency range on the accuracy of the sensor value. Ranges of 845-865 MHz produced the response in Fig. 11 which compares well with Fig. 8 for the original wider frequency range, though it can be seen that the reduced frequency range sensor code is less capable of discerning between smaller concentration levels (as demonstrated by the lowered R^2 value of Fig. 11 compared to Fig. 8).

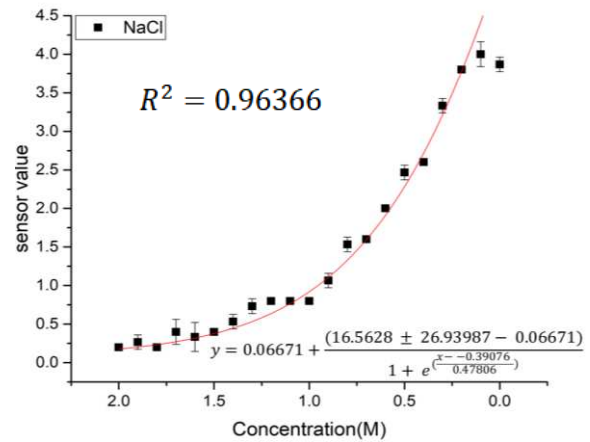

Fig. 11. The effect of NaCl salt solutions on the tag averaged sensor code at 845-865 MHz.

However, the error bars in Fig. 11 indicate a response stability that makes this smaller range repeatable (albeit less so than the wider measurement set for Fig. 8).

VI. CONCLUSION

The addition of a PDMS layer to the electrodes of an auto-tuning RFID tag enables it to compensate for the capacitive effect of bulk water solutions. The hydrophobic properties of the layer also mean that when the water is removed the tag performance returns to the original dry state. Furthermore, the sensor was exposed to 4 times the amount of solution that an unmodified tag can withstand before its sensing limit is reached. While increasing the applied film thickness does reduce the sensitivity of the tag, it will still operate as a moisture sensor up to a limit of around 1.8 mm. 500 μm was used as the film thickness for aqueous electrolyte monitoring as this thickness was thin enough to be more easily applied, whilst being thick enough to sufficiently isolate the capacitor from the analyte for sensing purposes. The effect of variable film thickness on aqueous electrolyte measurements is currently being investigated. The addition of the film enables

the tag to the sense dielectric properties of deposited solutions (using variable of concentrations of salts). Considering NaCl, this was found to be most effective when the concentration range varied between 0-2 M and had high repeatability. The large change in the $\tan \delta$ of NaCl solutions with increasing concentration results in an increased capacitive load on the sensing tag despite the fact the relative permittivity decreases. The sensor is proposed for low cost salinity monitoring applications such as brine concentration monitoring, or electrolysis monitoring. Having confirmed that the system operates effectively in a laboratory setting, future work will be focused upon utilizing an iteration of this system for aquarium salinity monitoring, with the sensor exposed to the analyte and the antenna to be sat above the water line.

ACKNOWLEDGMENT

This work was funded by the UK EPSRC project: EP/N009118/1.

REFERENCES

- [1] P. Kassal, M. D. Steinberg, and I. M. Steinberg, "Wireless chemical sensors and biosensors: a review," *Sensors Actuators B Chem.*, vol. 266, pp. 228–245, Mar. 2018.
- [2] J. Zhang, G. Y. Tian, A. M. J. Marindra, A. I. Sunny, and A. B. Zhao, "A review of passive RFID tag antenna-based sensors and systems for structural health monitoring applications," *Sensors*, vol. 17, no. 2, pp. 265–298.
- [3] A. Hulanicki, S. Glab, and F. Ingman, "Chemical sensors: definitions and classification," *Pure Appl. Chem.*, vol. 63, no. 9, pp. 1247–1250, 1991.
- [4] B. Violino, "Radio frequency identification has been around for decades. Learn how it evolved from its roots in World War II radar systems to today's hottest supply chain technology," *RFID J.*, 2005.
- [5] C. Swedberg, "Bagjack is using serfides' authentication software to track high-end messenger bags shipped from its german manufacturing site and, eventually, within a store. Bag maker adopts RFID solution to prevent counterfeits, gray market," *RFIDJournal*.
- [6] R. Want, "An introduction to RFID technology," *IEEE Pervasive Computing*, vol. 5, no. 1, pp. 25–33, 2006.
- [7] R. Aroca, A. Hernandez, D. Magalhães, M. Becker, C. Vaz, and A. Calbo, "Application of standard EPC/GEN2 UHF RFID tags as soil moisture sensors," *Proceedings*, vol. 1, no. 2, p. 10, Nov. 2016.
- [8] S. Kim, T. Le, M. M. Tentzeris, A. Harrabi, A. Collado, and A. Georgiadis, "An RFID-enabled inkjet-printed soil moisture sensor on paper for 'smart' agricultural applications," in *Proceedings of IEEE Sensors, 2014*, vol. 2014–Decem, no. December, pp. 1507–1510.
- [9] S. Dey, N. Karmakar, R. Bhattacharyya, and S. Sarma, "Electromagnetic characterization of soil moisture and salinity for UHF RFID applications in precision agriculture," in *2016 46th European Microwave Conference (EuMC), 2016*, pp. 616–619.
- [10] T. Glennon et al., "'SWEATCH': A wearable platform for harvesting and analysing sweat sodium content," *Electroanalysis*, vol. 28, no. 6, pp. 1283–1289, 2016.
- [11] D. P. Rose et al., "Adhesive RFID sensor patch for monitoring of sweat electrolytes," *IEEE Trans. Biomed. Eng.*, vol. 62, no. 6, pp. 1457–1465, Jun. 2015.
- [12] M. Novell, T. Guinovart, I. M. Steinberg, M. Steinberg, F. X. Rius, and F. J. Andrade, "A novel miniaturized radiofrequency potentiometer tag using ion-selective electrodes for wireless ion sensing," *Analyst*, vol. 138, no. 18, p. 5250, Aug. 2013.
- [13] R. A. Potyrailo et al., "RFID sensors as the common sensing platform for single-use biopharmaceutical manufacturing," *Measurement Science and Technology*, vol. 22, no. 8, pp. 82001–17, 2011.
- [14] R. A. Potyrailo, N. Nagraj, Z. Tang, F. J. Mondello, C. Surman, and W. Morris, "Battery-free radio frequency identification (RFID) sensors for food quality and safety," *J. Agric. Food Chem.*, vol. 60, no. 35, pp. 8535–8543, 2012.
- [15] R. A. Potyrailo, C. Surman, N. Nagraj, and A. Burns, "Materials and transducers toward selective wireless gas sensing," *Chem. Rev.*, vol. 111, no. 11, pp. 7315–7354, Nov. 2011.
- [16] S. Manzari, A. Catini, G. Pomarico, C. Di Natale, and G. Marrocco, "Development of an UHF RFID chemical sensor array for battery-less ambient sensing," *IEEE Sens. J.*, vol. 14, no. 10, pp. 3616–3623, Oct. 2014.
- [17] J. Siden, X. Zeng, T. Unander, A. Koptuyug, and H.-E. Nilsson, "Remote moisture sensing utilizing ordinary RFID tags," in *2007 IEEE Sensors*, pp. 308–311.
- [18] "RFM2100 wireless flexible moisture sensor - RFMicron." [Online]. Available: <http://rfmicron.com/rfm2100-wireless-flexible-moisture-sensor/>. [Accessed: 05-Dec-2017].
- [19] M. C. Caccami, S. Manzari, and G. Marrocco, "Phase-oriented sensing by means of loaded UHF RFID tags," *IEEE Trans. Antennas Propag.*, vol. 63, no. 10, pp. 4512–4520, 2015.
- [20] C. V. Rumens, M. A. Ziai, K. E. Belsey, J. C. Batchelor, and S. J. Holder, "Swelling of PDMS networks in solvent vapours; applications for passive RFID wireless sensors," *J. Mater. Chem. C*, vol. 3, no. 39, pp. 10091–10098, 2015.
- [21] M. C. Caccami and G. Marrocco, "Electromagnetic characterisation of self-tuning UHF RFID tags for sensing application," *2016 IEEE Antennas Propag. Soc. Int. Symp. APSURSI 2016 - Proc.*, pp. 1273–1274, 2016.
- [22] M. C. Caccami and G. Marrocco, "Electromagnetic modeling of self-tuning RFID sensor antennas in linear and nonlinear regimes," *IEEE Trans. Antennas Propag.*, vol. 66, no. 6, pp. 2779–2787, Jun. 2018.
- [23] "Voyantic Ltd. » Tagformance lite." [Online]. Available: <http://www.voyantic.com>.
- [24] R. Buchner, G. T. Hefter, and P. M. May, "Dielectric relaxation of aqueous NaCl solutions," *Phys. Chem. A*,

vol. 103, no. 1, 1999.

- [25] T. Chen, G. Hefter, and R. Buchner, "Dielectric spectroscopy of aqueous solutions of KCl and CsCl," *J. Phys. Chem*, vol. 107, pp. 4025–4031, 2003.
- [26] H. W. Harvey, "The chemistry and fertility of sea waters," *J. Mar. Biol. Assoc. United Kingdom*, vol. 35, no. 01, p. 289, Feb. 1956.
- [27] A. Peyman, C. Gabriel, and E. H. Grant, "Complex permittivity of sodium chloride solutions at microwave frequencies," *Bioelectromagnetics*, vol. 28, no. 4, pp. 264–274, May 2007.



Aaron J.R. Hillier received an M.Sc. degree in Forensic science from the University of Kent, Canterbury, UK, in 2015. He is currently pursuing a Ph.D. degree with the communication research group, and functional materials group, at the University of Kent. His current research interests include stimuli responsive polymers, passive sensing and body-centric antennas.



Viktorija Makarovaite (S'18) received a B.Sc. degree in biology and biochemistry in 2010 and two M.S. degrees in medical technology (currently known as MLS) (Rush University, Chicago, USA) and medical mycology (University of Manchester, Manchester, UK) in 2012 and 2015, respectively. She was an associate lecturer in the School of Engineering and Digital Arts at the University of Kent, Canterbury, UK. She holds board certification as a medical scientist (MLS generalist) with the ASCP since 2013.

Research interest include medical sensors, medical technology, biomedical engineering, RFID antennas and new materials. Currently pursuing a PhD in electrical engineering with a focus in sensor design for medical applications.



John C. Batchelor (S'93–M'95–SM'07) received the B.Sc. and Ph.D. degrees from the University of Kent, Canterbury, U.K., in 1991 and 1995, respectively. From 1994 to 1996, he was a Research Assistant with the Electronics Department, University of Kent, where he became a Lecturer of electronic engineering in 1997. He is currently the Leader of the Antennas Group at the University of Kent and the Professor of antenna technology. His current research interests include UHF RFID tag design, passive

sensing, body-centric antennas, printed antennas, compact multiband antennas, electromagnetic bandgap structures, and long-wavelength frequency selective surfaces.



Campbell Gourlay began his career at The John Innes Centre in 1996 where he completed a PhD in plant development, studying the genetic control of leaf development. He is a Reader in the School of Biosciences at the University of Kent. He established his own research group with the aid of Wellcome Trust Value in People Award and a Medical Research Council Career Development Fellowship in 2006. He is a founding member of the Kent Fungal Group (KFG) which represents one of the largest

collections of yeast research groups in the UK (<http://www.kentfungalgroupp.com/>). Current research projects include: The regulation of mitochondrial health and production of reactive oxygen species; The role of translational accuracy in healthy ageing and apoptosis; Roles for the actin cytoskeleton in regulating stress response mechanisms; Yeast as a model for motor neuron disease; Using yeast to understand the development of multi-drug resistance; The role of mitochondrial function in the pathogenicity of *Candida albicans*; The detection and management of biofilms on airway management devices.



Simon Holder researched for his PhD in organic Chemistry at the University of Hull under Dr David Lacey, as part of the Liquid Crystal Group. He received his PhD in 1993 and went on to work as a postdoctoral research fellow at the University of Kent on polysilane materials with Professor Dick Jones and subsequently on supramolecular materials at the University of Nijmegen with Professor Roeland Nolte. He was appointed as a Lecturer in Organic Chemistry at Kent in 1999 and a Reader in Organic Chemistry in 2013. Current research projects include the

development of materials for RFID sensors, novel polymer super-absorbents and self-assembling block copolymers.