

UNIVERSITY OF BIRMINGHAM

Research at Birmingham

The super-learning hypothesis

Caligiore, Daniele; Miall, Rowland; Arbib, Michael; Baldassarre, Gianluca

DOI:

[10.1016/j.neubiorev.2019.02.008](https://doi.org/10.1016/j.neubiorev.2019.02.008)

License:

Creative Commons: Attribution-NonCommercial-NoDerivs (CC BY-NC-ND)

Document Version

Publisher's PDF, also known as Version of record

Citation for published version (Harvard):

Caligiore, D, Miall, R, Arbib, M & Baldassarre, G 2019, 'The super-learning hypothesis: integrating learning processes across cortex, cerebellum and basal ganglia' *Neuroscience and biobehavioral reviews*, vol. 100, pp. 19-34. <https://doi.org/10.1016/j.neubiorev.2019.02.008>

[Link to publication on Research at Birmingham portal](#)

General rights

Unless a licence is specified above, all rights (including copyright and moral rights) in this document are retained by the authors and/or the copyright holders. The express permission of the copyright holder must be obtained for any use of this material other than for purposes permitted by law.

- Users may freely distribute the URL that is used to identify this publication.
- Users may download and/or print one copy of the publication from the University of Birmingham research portal for the purpose of private study or non-commercial research.
- User may use extracts from the document in line with the concept of 'fair dealing' under the Copyright, Designs and Patents Act 1988 (?)
- Users may not further distribute the material nor use it for the purposes of commercial gain.

Where a licence is displayed above, please note the terms and conditions of the licence govern your use of this document.

When citing, please reference the published version.

Take down policy

While the University of Birmingham exercises care and attention in making items available there are rare occasions when an item has been uploaded in error or has been deemed to be commercially or otherwise sensitive.

If you believe that this is the case for this document, please contact UBIRA@lists.bham.ac.uk providing details and we will remove access to the work immediately and investigate.



Review article

The super-learning hypothesis: Integrating learning processes across cortex, cerebellum and basal ganglia

Daniele Caligiore^{a,*}, Michael A. Arbib^b, R. Chris Miall^c, Gianluca Baldassarre^a^a Institute of Cognitive Sciences and Technologies, National Research Council, Via San Martino della Battaglia 44, 00185 Rome, Italy^b Department of Psychology, University of California at San Diego, La Jolla, CA 92093, USA^c School of Psychology, University of Birmingham, Birmingham, B15 2TT, UK

ARTICLE INFO

Keywords:

Cortex
Cerebellum
Basal ganglia
Unsupervised learning
Supervised learning
Reinforcement learning
Super-learning
Interplay between learning mechanisms
System-level neuroscience
Cortical-subcortical hierarchies
Neuromodulation
Dopamine
Serotonin
Noradrenaline
Acetylcholine

ABSTRACT

Despite wide evidence suggesting anatomical and functional interactions between cortex, cerebellum and basal ganglia, the learning processes operating within them –often viewed as respectively unsupervised, supervised and reinforcement learning– are studied in isolation, neglecting their strong interdependence. We discuss how those brain areas form a highly integrated system combining different learning mechanisms into an effective *super-learning* process supporting the acquisition of flexible motor behaviour. The term “super-learning” does not indicate a new learning paradigm. Rather, it refers to the fact that different learning mechanisms act in synergy as they: (a) affect neural structures often relying on the widespread action of neuromodulators; (b) act within various stages of cortical/subcortical pathways that are organised in pipeline to support multiple sensation-to-action mappings operating at different levels of abstraction; (c) interact through the reciprocal influence of the output compartments of different brain structures, most notably in the cerebello-cortical and basal ganglia-cortical loops. Here we articulate this new hypothesis and discuss empirical evidence supporting it by specifically referring to motor adaptation and sequence learning.

1. Introduction

It has been proposed that three different learning mechanisms operate within the brain: unsupervised learning, supervised learning, and reinforcement learning (Doya, 2000, 1999). *Unsupervised learning* is used by the brain to generate a mapping of the statistical regularities of the perceived environment (Hinton and Sejnowski, 1999). It can detect correlations in the input, and can be used to explain, for example, developmental processes such as the formation of receptive fields (Brito and Gerstner, 2016). Unsupervised learning can be implemented through Hebbian mechanisms so that related sensory or motor events become associated. Hebbian learning produces a persistent strengthening of synapses while weakening others, based on recent patterns of co-activity. For example, according to the Spike Timing Dependent Plasticity (STDP) protocol, strengthening occurs at a synapse if the postsynaptic neuron fires just after the presynaptic one (Abbott and Nelson, 2000; Markram, 1997). This process induces an increase in the excitatory postsynaptic potentials that lasts for minutes or hours (long term potentiation, LTP). If the relative timing is reversed so that the

presynaptic neuron fires after the postsynaptic one, the protocol produces a long-lasting decrease in synaptic strength (long term depression, LTD). STDP is only one example of a broader class of stimulation protocols that are all able to induce LTP and LTD (Artola et al., 1990; Frey and Morris, 1998; Ngezahayo et al., 2000).

In *supervised learning*, some internal neural component or an external agent supplies a desired output pattern (e.g., a desired action plan) that a network has to give in response to a certain input pattern. Based on the error between the desired pattern and the current output of the network, the instructed network learns to produce the desired output (Knudsen, 1994). The learning process is based on the minimization of the error: what makes this challenging is to ensure that changes over time reduce the average error over the whole training set. An important difference between supervised and unsupervised learning is that in the first the connectional strengths are not affected by the activity *per se* in the postsynaptic neurons, but only by the current discrepancy between their activity and the teaching signal. The modifiable synapses that are active concurrently with the teaching signals are strengthened, LTP, or weakened, anti-Hebbian LTD, in the direction

* Corresponding author.

E-mail address: daniele.caligiore@istc.cnr.it (D. Caligiore).<https://doi.org/10.1016/j.neubiorev.2019.02.008>

Received 27 July 2018; Received in revised form 11 February 2019; Accepted 15 February 2019

Available online 18 February 2019

0149-7634/ © 2019 The Authors. Published by Elsevier Ltd. This is an open access article under the CC BY-NC-ND license (<http://creativecommons.org/licenses/by-nc-nd/4.0/>).

that reduces the current discrepancy. The transformation signalled by the teacher may be “learned” in the sense that, once established, it will be carried out by the network in the absence of the teaching signal activity.

Reinforcement learning aims at maximizing the value of future action choices. Each action outcome is evaluated on the basis of the reward (or punishment) it (eventually) produces. The system selecting the different actions is hence modified depending on the reward obtained (Niv, 2009). However, reward may be intermittent, and temporal difference learning (Sutton, 1988; Sutton and Barto, 2018) provides a way of adjusting synapses involved in current actions to take account of eventual reward (or punishment), based on reward prediction error. In contrast to supervised learning, in the reinforcement learning the feedback given to the learning system is scarce. For example, if we take the task of riding a bicycle, in supervised learning the supervisor might signal the desired firing of the neurons that control deviation of the bike from vertical, at every moment in time, whereas in reinforcement learning the feedback might only signal failure (i.e., it hurts when you fall). In unsupervised learning, which is suitable to detect correlations in the input, there is no notion of success or failure, reward or punishment, and instead regular associations such as between upright riding and speed might be learned.

For almost two decades, disentangling these learning processes and trying to assign their implementation to distinct brain areas has been an important challenge for research in the neurosciences (Miall and Galea, 2016). Building on several empirical data, Kenji Doya proposed that unsupervised learning mainly operates within cerebral cortical areas, supervised learning in the cerebellum, and reinforcement learning in the basal ganglia (Doya, 2000, 1999). In support of this, we note that the anatomical organization of the thalamo-cortical circuits is critical to learning through unsupervised mechanisms forms of categorization of static and time-varying signals (Chandrashekar and Granger, 2011; George and Hawkins, 2009; Riesenhuber and Poggio, 1999; Rodriguez et al., 2004). The neural substrate of supervised learning mechanisms operating within the cerebellum could pivot on the LTD of parallel fiber synapses with the error signal provided by the climbing fibers (Ito, 1984; Kitazawa et al., 1998). Several data suggest that the neuromodulator dopamine provides basal ganglia target structures with phasic signals that convey a reward prediction error and that can influence reinforcement learning processes (Houk and Wise, 1995; Schultz, 1997). Therefore, in computational terms it is possible to characterize the functionality of the basal ganglia as an abstract search through the space of possible actions, guided by dopaminergic feedback.

A conundrum related to the cortico-cerebellar-basal ganglia system is its seemingly redundant nature: why are there three systems for producing one apparent function, namely the change of body-configurations in space? This problem is exacerbated by existing computational systems proposed as solutions to implement such function both by the neurobotics literature (Barto and Rosenstein, 2004; Caligiore et al., 2014; Eliasmith et al., 2012; Spoelstra and Arbib, 2001) and the brain-modelling research (Arbib and Bonaiuto, 2016; Caligiore et al., 2016b; Prescott et al., 2006). In most cases, the models are based on one, sometimes two, principles/components (e.g., models of basal ganglia or cerebellum learning to capture the acquisition and production of motor behaviour). Why has evolution solved the motor problem using three different systems? The three brain systems are necessary as they act at different *time* scales (the cerebellum may operate at a fast scale, the basal ganglia and cortex at a slower scale) and at different *space* scales (the cerebellar vs. basal ganglia different granularity, and the cortex operating at multiple scales) (Chen et al., 2014; DeLong and Strick, 1974; Edelman, 2001). Moreover, the three systems are necessary as they have *some* degree of specialisation with respect to the three learning mechanisms, in line with the initial proposal by Doya (Doya, 1999). Several scholars have elaborated on this perspective, specifying different functions implemented by these brain areas during motor learning. For example, it has been suggested that the basal ganglia learn

rewards associated with cortical sensory states and then estimate the “cost-to-go” during the execution of motor tasks, whereas the cerebellum builds on supervised learning processes to acquire internal models of the controlled system (Shadmehr and Krakauer, 2008). These comprise forward models, predicting the sensory outcome of motor commands performed in a given condition, and inverse models, learning to produce motor commands in order to accomplish a given goal in a given condition (Wolpert et al., 1998). Houk and colleagues proposed that during motor learning the basal ganglia-thalamo-cortical system learns how to regulate selection and initiation of a motor pattern within the cortical areas, whereas cerebello-thalamo-cortical circuits learn how to refine that pattern. According to this view, the cerebellum does not provide a full inverse model, but rather acts as a sidepath to compensate crude or incomplete commands from cerebral cortex to yield accurate movements that can support swift confident behaviour (Houk et al., 2007).

Despite a large amount of data suggesting anatomical and functional interactions between cortex, cerebellum and basal ganglia (Alexander et al., 1986; Bostan et al., 2010; Middleton and Strick, 2000), the different forms of learning implemented within these brain areas are often studied in isolation, neglecting mechanisms that underlie their dynamical interplay during skill acquisition (Caligiore et al., 2016b, 2013b). Studying unsupervised, supervised and reinforcement learning separately makes it necessary to isolate from the environment the training information used by the single process (e.g., the regularities of the perceived environment for unsupervised learning or the reward for reinforcement learning). It also prevents comprehension of how the brain manages the richness of training information in realistic learning problems, in which combinations of all three learning mechanisms are the rule rather than the exception. For example, when we learn to ride a bike, we may simultaneously learn the sequence of movements needed to accomplish the task through explicit supervised training (e.g., someone instructs us to perform the task), implicit means (e.g., we practice by ourselves), and with both trial and error and unsupervised association co-occurring during each attempt.

In this article, we discuss how cortex, cerebellum and basal ganglia might operate in an integrated fashion on the basis of a close interaction between unsupervised, supervised and reinforcement learning processes. We propose that the key features of these forms of learning synergise in different ways according to the specific task to be learned, thus giving rise to a *super-learning process* involving the whole cortico-cerebellar-basal ganglia system. This process builds on two critical features: (i) the *cortical-subcortical hierarchical organization of neural pattern selection* operating at *different levels of spatial and temporal granularity*, and (ii) the combined action of different neuromodulators which regulates the concurrent learning in the three areas. The term “super-learning” does not refer to any new learning paradigm. Rather, it indicates the boost in learning obtained when many different learning mechanisms work together across multiple brain regions.

In the rest of the paper, we discuss how the super-learning hypothesis might explain the seemingly redundant nature of the cortico-cerebellar-basal ganglia system to solve motor learning problem. In particular, we first discuss how the anatomo-physiological features (i-ii) underlie the emergence of computational processes which foster the synergistical interplay between unsupervised, supervised and reinforcement learning (Section 2). We also set the stage for a deeper analysis of super-learning processes by presenting the overall anatomical architecture of two main brain hierarchies within which super-learning takes place: the hierarchy formed by the cerebral cortical pathways, and the hierarchy involving the basal ganglia-thalamo-cortical loops and the cerebello-thalamo-cortical loops (Section 3). For the sake of focus, we then discuss this hypothesis with reference to two widely studied motor learning problems: sequence learning and adaptation (Diedrichsen and Kornysheva, 2015; Penhune and Steele, 2012; Shmuelof et al., 2012) (Section 4). We discuss (Section 5) how the super-learning hypothesis is supported by recent evidence studying the

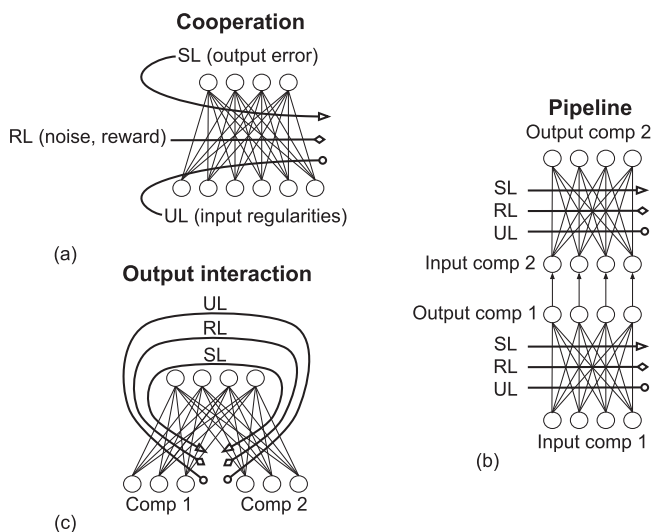

Fig. 1. Three main classes of mechanisms through which super-learning can take place. (a) Different learning signals and processes from supervised, reinforcement, and unsupervised learning (respectively SL, RL, and UL) concur to modify the same neural structures, either at the same time or at different times. (b) Different brain components using different learning mechanisms influence each other by performing computations in a pipeline. (c) Different brain components using different learning mechanisms influence the learning of each other by sharing their output neural layers.

reciprocal influences between the three learning processes. Finally, we discuss how the proposed super-learning hypothesis furnishes answers to several open issues in motor learning literature (Section 6), and draw the conclusions of our analysis (Section 7).

2. Overview of the super-learning elements

Super-learning involves an integrated operation of unsupervised, supervised, and reinforcement learning processes. This integration can take place in several different ways that can be grouped in three different general classes now considered in detail (see Fig. 1).

A first class of processes through which different learning mechanisms can interact is the *cooperation* of supervised, reinforcement, and unsupervised learning signals and processes over the same neural structures (Fig. 1a). This means that, for example, aside from driving reinforcement learning, reward-related signals could also modulate the effectiveness of supervised learning (Doya, 2002), or that unsupervised learning process could be effective to maximize information transfer during supervised learning processes (Schweighofer et al., 2001). The mutual interaction of learning signals could be regulated by the diffused action of neuromodulators, mainly dopamine, noradrenaline, serotonin, and acetylcholine, within cortex, basal ganglia and cerebellum. For example, dopamine and serotonin are important to drive reinforcement learning (Fischer and Ullsperger, 2017; Schultz, 1997) but also to regulate the interplay between supervised and reinforcement learning processes (Schweighofer et al., 2004). Noradrenaline further supports this interaction by regulating the exploration/exploitation components of trial-and-error behaviour (Doya, 2002), whereas acetylcholine contributes to consolidate the interaction between unsupervised and reinforcement learning processes (Fonollosa et al., 2015; Hasselmo, 1995).

A second class of mechanisms supporting super-learning is the *pipeline* organization of different brain systems, possibly partially overlapping, undergoing unsupervised, supervised and reinforcement learning processes (Fig. 1b). The order of the learning mechanisms taking place in the pipeline depends on both contextual information (e.g., the task at hand) and on the body state (e.g. the currently prevailing needs and motivations). The cortical-subcortical hierarchical

organization of neural pattern selection operating at different levels of spatial and temporal granularity supports the pipeline organization of different learning processes. For example, the basal-ganglia input stage, the striatum, uses the information received by the cortical areas to select (through disinhibition) target portions of the thalamo-cortical loops (Alexander et al., 1986; Houk and Wise, 1995). In this architecture, the cortex, for example parietal associative areas, might use unsupervised mechanisms to extract suitable information from percepts and send it to the basal ganglia that then use reinforcement learning to acquire the capacity to select suitable actions executed at the level of motor cortex (Gurney et al., 2001).

A third class of mechanisms supporting super-learning involves the reciprocal influence of different brain components (e.g., basal ganglia, cerebellum) using different learning mechanisms, through their *output interaction* (Fig. 1c). In particular, they happen when the output compartment of a certain network is activated by the output of a second network, and this influences the learning processes of the first component. The influence is due to the fact that the output of a neural structure is critical to guide its learning processes through both reinforcement and supervised learning. The reciprocal influence of the two neural circuits can take place either because (a) the two components share a common output compartment, or (b) because the output of one circuit reaches the output of the other through suitable neural connections. Again, which circuit learns from which, and when, might depend both on contextual information and on needs/motivations. As an example, consider the possible interaction between the basal ganglia-cortical loops and the cerebellar-cortical loops in the case of motor adaptation. Motor adaptation leads to update of an existing motor skill when the conditions in which it was initially acquired change. In this case, reinforcement learning involving basal ganglia might be critical to quickly acquire a gross solution to the perturbation, improving performance but below the baseline level. Then a supervised learning process, possibly involving cerebellum, might contribute to refining this initial solution, thus gradually recovering the baseline level of performance (Doyon et al., 2003a; Shadmehr and Holcomb, 1999).

The three classes of interactions can involve each of the three possible pairs of learning mechanisms (Fig. 2). For each pair, cooperation can happen only in one way, e.g. with supervised learning (SL) and

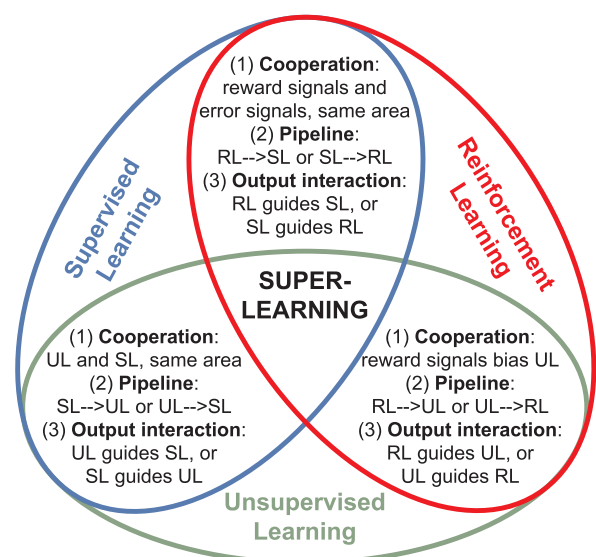

Fig. 2. The possible interactions between supervised learning (SL), reinforcement learning (RL), and unsupervised learning (UL). The three classes of possible interactions supporting super-learning (co-occurrence of different learning mechanisms; link of structures in pipeline; influence via the output) can involve each pair of learning mechanisms.

reinforcement learning (RL) processes updating the synapses of the same neural area (Fig. 1a); although, the two learning processes might have a different relative intensity. Instead, the interactions based on the pipeline organisation (Fig. 1b) can take place in two ways depending on which learning process influences which other learning process. Also the interaction based on output relationships can happen in two forms depending on which output uses a certain learning process to guide the learning of another component using a different learning process. The combinations of the five interaction modalities with the three possible pairs of learning mechanisms give rise to fifteen ($5 \times 3 = 15$) different possibilities. We give here some examples of a subset of these to show the capacity of this framework to capture interesting learning processes, that might involve either brain networks or artificial neural networks. Some of these examples will be expanded in the rest of the paper to show their biological detail and importance (see for example, Sections 4 and 5). The cases for which concrete examples are not yet known might furnish “predictions by symmetry” representing heuristic hypothesis to investigate with empirical experiments, in biological or artificial neural network models.

Regarding first SL-RL cooperation, the cerebellum might implement SL and at the same time some forms of dopamine-based RL (Ikai et al., 1992; Wagner et al., 2017). Regarding SL-RL organised in pipeline, during action sequence learning (Section 4.2) the cerebellum might support RL by providing the timing information needed from the basal ganglia-cortical system to properly chunk different motor acts. The connections between cerebellar nuclear outputs and the striatum of the basal ganglia might be important to convey such timing signal to the basal ganglia (Bostan et al., 2010). Regarding SL-RL output interaction, in the case of motor adaptation considered above initially basal ganglia might use RL to find a coarse-grained solution and cerebellum SL processes might be guided by it. Then the cerebellum might refine the found solution using SL (Houk et al., 2007; Houk and Wise, 1995), and basal-ganglia use RL to “copy” such solution (Barto and Rosenstein, 2004).

Regarding UL-RL cooperation, these processes might for example coexist at the level of learning of striatum in basal ganglia, as also shown with computational models (Mannella and Baldassarre, 2015). Pre-processing of sensorial information is indeed very important for an effective functioning of RL (Lesort et al., 2018). Regarding UL-RL organised in pipeline, in the example considered above cortex might use UL to find suitable representations of sensory inputs, and then pass it to basal ganglia that might implement RL. In turn, the basal ganglia (RL) select thalamo-cortical representations that might in turn involve other UL processes (Baldassarre et al., 2013; Dominey and Arbib, 1992; Gurney et al., 2001; Yin and Knowlton, 2006). Regarding UL-RL output interactions, it has been proposed on the basis of substantial empirical evidence that associative processes involving different areas of cortex might link neural populations selected in those areas by basal ganglia (Hélie et al., 2015). We do not have examples of UL guiding RL processes.

Regarding UL-SL cooperation, the current revolution of machine learning started around 2006 with the proposal of the technique to use UL to pre-train deep neural networks (neural networks formed of many stacked layers of neurons) before training them with SL (Goodfellow et al., 2016). This allowed a solution to the “vanishing gradient problem” that prevented successful training of deep neural networks with UL alone. Although this problem is now commonly solved in other ways (most notably with the use of “rectified linear units”), it suggests a powerful computational mechanism that might also operate in the brain (Dahl et al., 2013; Jiang et al., 2018). The brain can indeed be considered a deep neural network if it uses SL, e.g. at the level of cerebellum, it might use UL mechanisms to support it. Regarding UL-SL organised in pipeline, some examples come from the cerebellar loops with cortex, analogous to basal ganglia-cortical loops. In this case the cortex, putatively hosting UL processes, furnishes inputs to cerebellum that might refine motor behaviour on the basis of SL processes and then

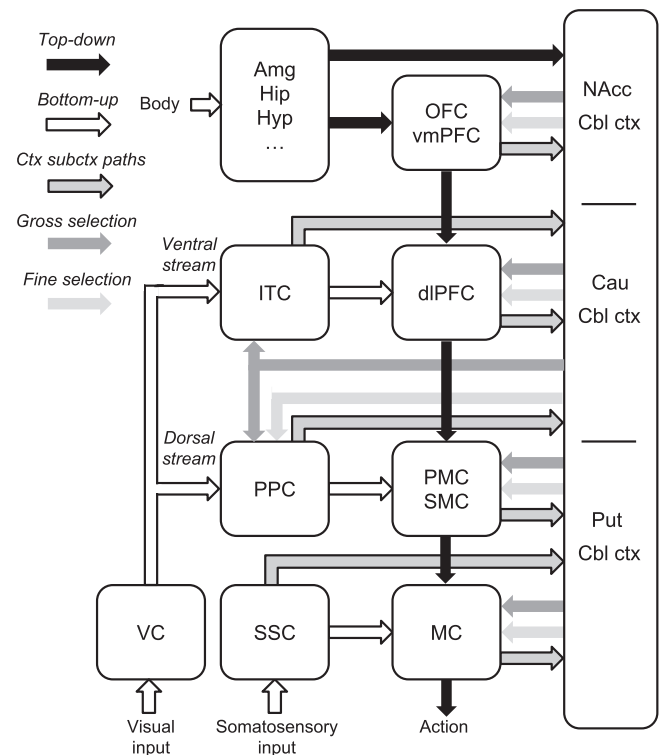

Fig. 3. The cortical and subcortical system where super-learning takes place. Abbreviations: Amg: Amygdala; Cau: Caudatum; Cbl ctx: cerebellar cortex; dIPFC: dorsolateral prefrontal cortex; Hip: Hippocampus; Hyp: Hypothalamus; ITC: inferotemporal cortex; MC: motor cortex; NAcc: nucleus accumbens; OFC: orbitofrontal cortex; PPC: parietal cortex; PMC: premotor cortex; Put: putamen; SMC: supplementary motor cortex; SSC: somatosensory cortex; VC: visual cortex; vmPFC: ventromedial prefrontal cortex.

influence motor cortex and sub-cortical areas (Schweighofer et al., 2001). Last, regarding UL-SL output interactions we do not have direct examples, but it would be interesting to investigate if cerebellar output could guide the associative learning processes taking place in cortex, as proposed for basal ganglia (Hélie et al., 2015).

The different classes of possible interactions between the three forms of learning processes are embedded in the system-level macro architecture of brain. In particular, the two classes of pipeline interactions and output-based interactions are manifest within the hierarchical pathways and closed loops of the basal ganglia-cortical and cerebellar-cortical loops, performing action selections at different time/space scales. The remaining class - cooperation interactions - takes place within the neural stages of such pathways and loops. The next section thus considers these pathways and loops more in detail.

3. Neural mechanisms producing super-learning

Fig. 3 summarises the brain macro anatomy within which super-learning takes place. The figure shows how the anatomy integrates two important brain hierarchies. By “brain hierarchy” we refer to two or more partially segregated systems where one system exerts control over the other systems, that is stronger than the control that the latter ones exert on the former. The first hierarchy involves the ventro-dorsal organization of cortical pathways that process sensorimotor information at increasingly levels of complexity and abstraction, from sensorimotor execution, to affordance-based motor preparation, to goal-directed behaviour driven by motivations (Bonaiuto and Arbib, 2015; Caligiore et al., 2013a, 2010; Thill et al., 2013). The second hierarchy involves basal ganglia-thalamo-cortical loops and cerebellar-thalamo-cortical loops performing selections at different levels of space and time

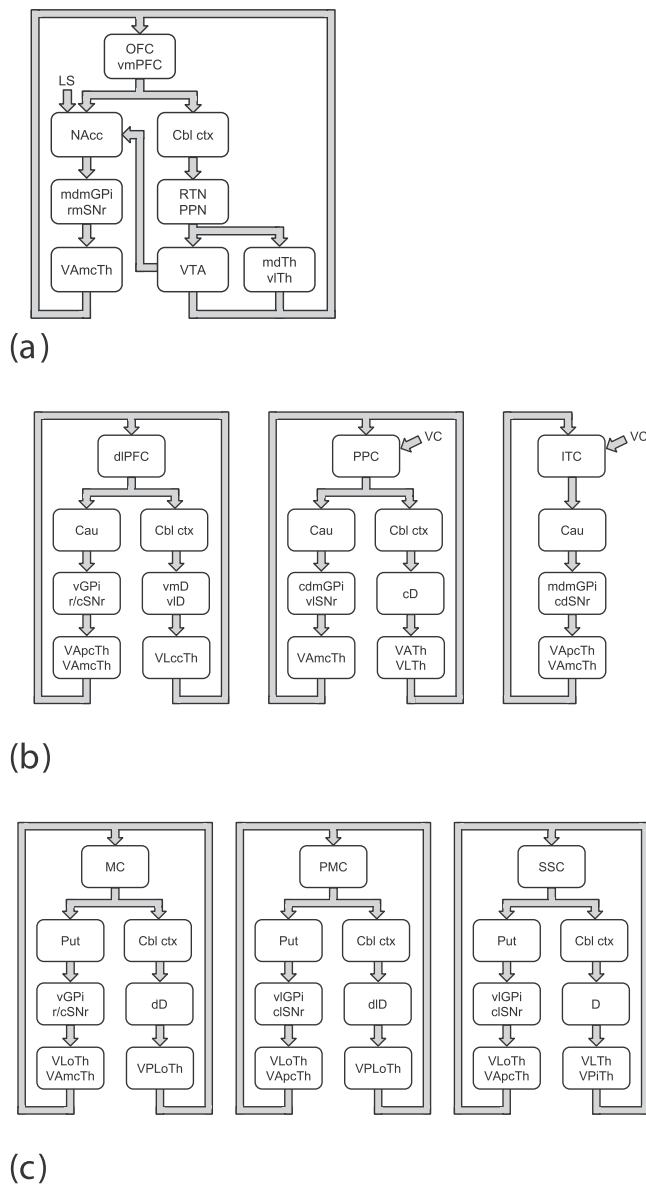

Fig. 4. Sketch of the main anatomical features of the cortico-cerebellar-basal ganglia system supporting super-learning. The figure shows the basal ganglia- and cerebellar- thalamo-cortical loops involved in the selection of biologically relevant goals based on body states and emotional processing (a), in the selection of motor plans (b), and in motor preparation and execution (c). Abbreviations: c: caudal; Cau: Caudatum; Cer ctx: cerebellar cortex; cl: caudolateral; D: dentate nucleus; dIPFC: dorsolateral prefrontal cortex; dm: dorsomedial; GPI: internal globus pallidus; ITC: inferotemporal cortex; mdm: medial dorsomedial; LS: limbic system; MC: motor cortex; MDmf: pars multiformis mediodorsal thalamic nuclei; NAcc: nucleus accumbens; OFC: orbito-frontal cortex; PC: parietal cortex; PMC: premotor cortex; PPN: pedunculo pontine nuclei; Put: putamen; rd: rostrorodorsal; RTN: reticulo tegmental nucleus; SMC: supplementary motor cortex; SNc: substantia nigra, pars compacta; SNr: substantia nigra pars reticulata; SSC: somatosensory cortex; Th: thalamus; VAmc: ventral anterior medial part; VAp: ventral anterior pars principalis; vl: ventrolateral; VC: visual cortex; VLcc: ventral lateral caudal portion of thalamus; vm: ventromedial; vmPFC: ventromedial prefrontal cortex; VTA: ventral tegmental area; VS: visual cortex; r: rostral.

granularity (Alexander et al., 1986; Baldassarre et al., 2013; Middleton and Strick, 2000; Sakai, 2013; Sakai and Grofovà, 2002). In the following sections we consider these two hierarchies more in detail.

3.1. Cortical hierarchies where super-learning operates

Fig. 3 shows how the first hierarchy – the ventro-dorsal organization of cortical pathways – processes sensorimotor information at increasingly levels of complexity and abstraction. We consider the functions of these cortical pathways by solely referring to cortex but as we shall see in the next section most cortical areas form highly integrated sub-systems with different portions of basal ganglia and cerebellum. These subsystems actually underlie all the functions we now consider.

The apex of the first hierarchy is formed by cortical frontal regions, in particular OFC and vmPFC (see Figs. 3,4 for the meaning of the abbreviations) (Fuster, 2015; Passingham and Wise, 2012), that strongly communicate with important subcortical areas, in particular Amg, Hip, Hyp, NAcc, a set of areas once called the “limbic brain” (Mogenson et al., 1980). The latter areas are directly and indirectly connected with the visceral body and can so collect information on the organism’s current needs, for example for energy and nutrition, pain avoidance, and fatigue containment. Based on this information, and on a close interplay with the subcortical nuclei important for neuromodulation (e.g., VTA, SNc, LC), this system can attribute a biological valence to stimuli and action outcomes related to the resources in the environment that can satisfy those needs (Mannella et al., 2016; Mirolli et al., 2010). The limbic system and various areas of PFC also support the processes related to *intrinsic motivations* related to the acquisition of knowledge and competence rather than material resources (Baldassarre and Mirolli, 2013). For example, novel objects or novel object relations are detected by Hip that activates both the NAcc and the dopaminergic system to foster exploration and learning processes targeting those objects (Lisman and Grace, 2005; Mannella et al., 2013).

Within the second level of the hierarchy, formed by the VC-ITC “ventral pathway” (Goodale and Milner, 1992) and the downstream PFC regions (most notably dIPFC), motivational information influences the representations of objects in the environment (Mannella et al., 2013). For example, the need of caffeine might activate the goal of “drinking coffee” and drive the formulation of a motor plan to achieve it, for example to prepare a mug of coffee (Giovannetti et al., 2007; Goldenberg and Iriki, 2007). The working memory and episodic memory for which dIPFC and Hip play a major role can host information that is elaborated to assemble the plan, and then to store it for execution (Miller and Cohen, 2001; Thill et al., 2013). If instead there is an already available mug with coffee, a motor sequence might be triggered to accomplish the desired goal: “reach and grasp handle; lift mug; bring it to the lips; drink.” In both cases, the preparation of the single motor acts and their assembling into suitable sequences takes place at the lower level of the hierarchy.

The third level of the hierarchy is formed by the “dorsal pathway”, including the VC and the PPC (Goodale and Milner, 1992) encoding affordances; that is, they process visual information such as object location, orientation and size to support different possible motor actions (Caligiore et al., 2010; Fagg and Arbib, 1998; Fogassi, 2005). This information reaches the PMC, where it fuels the preparation of motor acts such as reaching and grasping (Bonaiuto and Arbib, 2015), and the SMC, where it contributes to assemble the motor acts into sequences (Nachev et al., 2008).

The lowest, fourth, level of the hierarchy, relying on the highly dynamical circuit formed by the SSC, receives information on the state and dynamics of the skeleto-muscular system. This information, suitably integrated with motor plans from PMC, is sent to the MC to contribute to issuing motor commands to muscles in order to perform the desired motor acts, for example to reach a mug (Churchland et al., 2012).

3.2. Subcortical hierarchies where super-learning operates

We now focus on the second hierarchy – formed by cortical-basal ganglia loops and cortical-cerebellar loops, performing action selections

at different granularities of space and time. As already observed, the sensorimotor transformations performed by the cortical pathways are strongly supported by cortical-subcortical loops involving basal ganglia (BG) and cerebellum (Cbl). A notable anatomical feature supporting this view is that the BG and Cbl loops are partially segregated into “macro-loops,” each connected with specific macro-areas of cortex (Fig. 4). These areas tend to correspond to the different levels of the cortical hierarchy illustrated in the previous section, but they also exhibit some exceptions reflecting the fact that both BG and Cbl have a gradient of connectivity strength with Ctx that increases moving from the lower to the higher levels of the cortical hierarchy, and from the sensory/input areas with no connections to the primary sensory areas towards the motor/output areas with dense interconnections.

We can distinguish three Ctx-BG and Ctx-Cbl macro-loops (Baldassarre et al., 2013; Gurney et al., 2001; Middleton and Strick, 2000; Yin and Knowlton, 2006). The first (Fig. 4a) is linked to the apex of the cortical hierarchy subserving the motivational processes. The second (Fig. 4b) mainly involves the areas of the ventral pathways (ITC, vmPFC), but the perceptual areas of the dorsal pathway (PPC), are also important for selecting goals and formulating plans to achieve them. And the third (Fig. 4c) involves all the motor areas, in particular those of the dorsal pathway (PMC, SMC) and those of the somatosensory-motor pathway (SSC-MC). We next highlight the internal anatomy of these loops and how they support the selection of cortical contents at different levels of granularity and then consider how the BG and Cbl implement specific functions and complement each other within each of the three macro-loops.

3.2.1. Computational views of the micro-anatomy of basal-ganglia and cerebellum: selection at different granularities of time and space

The selection of patterns within cortex is often attributed to its intrinsic computational properties (Cisek and Kalaska, 2010; Diedrichsen and Kornysheva, 2015; Kappel et al., 2014). However, these cortical selection processes are strongly supported by both BG-Th-Ctx loops (Baldassarre et al., 2013; Graybiel, 1998; Gurney et al., 2001; Mannella and Baldassarre, 2015; Yin and Knowlton, 2006) and Cbl-Th-Ctx loops (Gurney et al., 2001; Houk et al., 2007; Houk and Wise, 1995; Middleton and Strick, 1998). In the BG, the striatum and the subthalamic nucleus (STN) are the primary input structures and receive projections from most regions of cortex. The striatum sends GABAergic inhibitory connection to the GPi and SNc (the “direct pathway”) forming the BG output stage (Hikosaka et al., 1993; Liu and Basso, 2008). These nuclei are also reached by the glutamatergic excitatory connections of the STN (the “hyperdirect pathways”). The striatum also inhibits the GPe which in turn inhibits the STN (the “indirect pathway”). The BG output nuclei send GABAergic inhibitory projections to the thalamus which in turn exchanges excitatory connections with the cortex thus creating parallel cortico-striato-pallidal/nigro-thalamo-cortical loops (DeLong, 1990; Feingold et al., 1996). A widely accepted model of the BG proposes that the double inhibition mechanism of the BG direct pathway, modulated by the indirect and hyperdirect pathways and VTA/SNpc dopamine, represents a major mechanism the brain uses to select cortical patterns (Chevalier and Deniau, 1990; Frank, 2005; Gurney et al., 2001). In particular, based on the pattern of input from Ctx, each BG macro-loop can disinhibit different BG-Th-Ctx channels, thus allowing the corresponding cortical pattern to be activated. This model also posits that neuromodulators, mainly dopamine, regulate these channels in correspondence to certain external/internal contexts (Gurney et al., 2001; Houk and Wise, 1995).

Alongside BG-Ctx loops, the Cbl-Ctx loops are also considered to give an important contribution to the selection of cortical patterns (Bostan and Strick, 2018; Houk et al., 2007). The mossy fibers bring excitatory input to the Cbl, in particular to the granule cells. The granule cells in turn project to Purkinje cells through excitatory parallel fibers. The Purkinje cells send inhibitory projections to the Cbl deep nuclei which also receive excitatory signals from the mossy fibers.

Based on the difference of the two inputs, the deep nuclei send inhibitory projections to cells of the inferior olive that in turn project to Purkinje cells through excitatory climbing fibers. Within the cerebellar cortex, parallel fibers also activate basket and stellate cells that inhibit Purkinje cells, and activate Golgi cells that inhibit the granule cells themselves. A classic view of cerebellar function (Albus, 1971; Marr, 1969) proposes that the Purkinje cells implement a predictor of the mossy fiber signal, adjusting its prediction based on a prediction error encoded by the climbing fibers. In particular, when the prediction is correct, the net input to the deep-nuclei cells from a Purkinje cell (predictor) and the mossy fibers (signal to predict) is zero. Instead, if the Purkinje cell output is too high, the deep-nuclei cells disinhibit the inferior olive cells so that the climbing fiber signal causes a depression of the parallel fiber-Purkinje cell synapses, the Purkinje cell output is decreased, and the error is adjusted towards zero. Vice versa if the Purkinje cell prediction is too low. Depending on the input and the desired output to predict, this circuit can learn to implement either forward models, useful to anticipate future events, or inverse models, useful to produce the control commands needed to achieve desired effects. In particular, in the case of forward models the input is the current state of a system (e.g., the body and/or the world) and a programmed action, and the desired output is the future state to predict. In the case of inverse models the input is the current state and the future goal state of a system, and the desired output is the action to perform to achieve the goal state. Similarly to the basal ganglia, the cerebellum also receives VTA/SNc dopaminergic projections that regulate its learning processes (Ikai et al., 1992; Melchitzky and Lewis, 2000; Panagopoulos et al., 1991).

The micro-features of the anatomy of the BG and Cbl loops is at the basis of their operation at different time and space scales. The output stages of the BG contain far fewer neurons than the input from the cortex (Felleman and Van Essen, 1991) thus making the BG channels ideally suited for coarse-grained selection of whole neural assemblies within the Th-Ctx targets (Graybiel, 1998; Mannella and Baldassarre, 2015; Redgrave et al., 1999). This allows the BG to, for example, select specific predictions of the future (dIPFC), or action sequences (SMC), actions (PMC), and coarse-grained movement via-points (MC) to be performed. This however does not ensure accuracy and graceful execution. The Cbl instead provides the necessary modulation, for example to refine predictions at fine time scales, to smoothly link motor acts in sequences, or to execute accurate motor trajectories by working on fine timing and co-articulation (Ito, 2013; Spoelstra and Arbib, 2001).

This role is supported by the Cbl organization into microcomplexes each comprising a set of Purkinje cells and cerebellar nuclei neurons (Ito, 1997). Inhibitory cells within the cerebellar cortex may play a role in sculpting which microcomplexes are active (Arbib and Spoelstra, 1997). Each set of Purkinje cells might then modulate the performance of an action selected by BG-Ctx via a cerebellar nuclei cell assembly that in turn tunes the parameters of a motor pattern generator outside the cerebellum, for example in the spinal cord or in the motor cortex; this broadly fits with the concept of inverse model considered above. Motor pattern generators might be located in the spinal cord, brainstem or cortex, thus affecting the selection of neural patterns that produce movement features such as force, velocity, timing and co-articulation (Arbib and Spoelstra, 1997; Ito, 2013; Schweighofer et al., 1996a). In this way, the Cbl refines the details of the movement trajectory. The basal ganglia is also involved in the regulation of these dynamical aspects of movement (Turner and Desmurget, 2010; Yttri and Dudman, 2016). These mechanisms allow the improvement of the quality of movements, gradually recovering the baseline level of performance. The Cbl also acts at a finer time scale, down to milliseconds, with respect to BG that operates at the level of up to tens of seconds (Bareš et al., 2018a; Petter et al., 2016a). Schweighofer and colleagues proposed computational models that operationalise this view by showing how the Cbl may help to ensure the accuracy of the saccade brainstem

generator compensating for the nonlinearities in the movement pattern generator. They also show that a cerebellar model based on the microcomplex hypothesis could improve coordination of different joint movements during reaching (Schweighofer et al., 1998, 1996a, 1996b).

3.2.2. The cortical hierarchies where super-learning operates

3.2.2.1. The motivational loop. The first BG-Ctx macro-loop is the “motivational loop” (Yin and Knowlton, 2006). This loop involves the ventral part of the striatum (or nucleus accumbens, NAcc) which receives important information on the innate or acquired value of stimuli from various subcortical components of the limbic system (LS) such as the Amg, Hip and Hyp. Based on this information, this portion of the BG helps select biologically relevant stimuli and goals encoded in OFC/vmPFC. The NAcc is also at the apex of a “motivational hierarchy” that, through “dopaminergic spirals” involving different portions of striatum and VTA/SNpc, transmits information on stimulus value to downstream BG-Ctx macro loops and hence helps regulate BG learning (Haber, 2003; Haber et al., 2000).

Cbl also connects with subcortical structures including Amg, Hip, and Hyp, on which basis it plays a role in emotional processing (Blatt et al., 2013). In particular, by contributing to control the VTA dopaminergic release, the Cbl exerts an indirect influence on NAcc, and on OFC/vmPFC (Fig. 4a) (Rogers et al., 2013), for example affecting memory consolidation (D’Ardenne et al., 2012; Puig et al., 2014).

3.2.2.2. The associative loop. The second BG macro-loop is the “associative loop” shown in Fig. 4b (Yin and Knowlton, 2006) which involves important temporo-parieto-frontal cortical regions involved in goal-directed behaviour (Passingham and Wise, 2012). The loop is in particular formed by the dorsomedial part of the striatum (caudate nucleus - Cau) and contributes to select cortical patterns related to the currently valuable goals (dlPFC) (Mannella et al., 2013), and the relevant objects (ITC) and possible actions (the affordances in PPC) to pursue them (Miller and Cohen, 2001).

Cbl shares a set of discrete parallel loops with various parts of the fronto-parietal cerebral network (Fig. 4b). In particular, visual area within the dorsal pathway (PPC) projects to pons, whereas cortical regions within the ventral pathway, such as vmPFC and OFC, do not have pontine projections (Schmahmann and Pandya, 1997). Moreover, the output channels of the Cbl ventral dentate project to dlPFC contributing to working memory and planning processes (Middleton and Strick, 2000). The Cbl-PPC loops support the coordination of actions (Ramnani et al., 2001). Information coming from the ventral dentate output of the cerebellum might support the coordination between the dorsal areas of the PPC and dlPFC areas to represent high-level goals, i.e. representations of desirable possible future states of the environment (Thill et al., 2013), in particular taking into account the temporal relationship between task-relevant events (D’Angelo and Casali, 2012). In this respect, by working with the Cbl the dlPFC might acquire the capacity to anticipate future events based on Cbl forward models (Ito, 2008; Wolpert et al., 1998). This view is in line with the “timing hypothesis” according to which the cerebellum is crucial for representing the temporal relationship between task-relevant events by working as a general “timing co-processor” whose particular function depends on the targeted brain regions (D’Angelo and De Zeeuw, 2009).

3.2.2.3. The sensorimotor loop. The third and last BG-Ctx macro-loop is the “sensorimotor loop” (Yin and Knowlton, 2006). This loop involves the dorsolateral part of striatum (putamen - Put) of the BG that contribute to selection of suitable motor patterns within the PMC in correspondence to specific stimuli (habits). This selection is influenced by a top-down bias from the higher level BG-Ctx associative loop (Mannella et al., 2016). The selected motor patterns are then specified by selective processes involving the MC forming highly dynamic motor circuits with the somatosensory regions of the PPC (Churchland et al., 2012).

The dorsal dentate nucleus of the Cbl projects to PMC, SMC and MC (Fig. 4c) (Middleton and Strick, 2000). In addition, the output channels in the ventral dentate nucleus of the cerebellum project to pre-SMA (Akkal et al., 2007). These connections play a crucial role in detailing the motor trajectories issued by MC, and reaching the skeletomuscular motor plant through the descending motor pathways. For example, the loops with MC are presumably involved in adjusting motor commands to compensate for movement dynamics, whereas the loops involving SMC and PMC may be involved in predicting the immediate consequences of intended movements, e.g. to overcome the delays of sensory feedback (Botzer and Karniel, 2013). These processes thus ensure that graceful movements are executed (Arbib and Spelstra, 1997; Spelstra and Arbib, 2001).

4. Super-learning during motor adaptation and sequential learning

4.1. Reinforcement learning supports supervised learning in motor adaptation

Motor adaptation is usually distinguished from skill learning. Motor adaptation involves the update of an existing motor skill when there is a change of the conditions in which it has been initially acquired, for example when learning to drive a new car or adapting to physical changes following an injury (Wolpert et al., 2011). We focus on motor adaptation as it involves the learning of the basic behaviour building blocks, the motor acts, and at the same time there is a relevant amount of empirical evidence on it. These processes happen especially in early stages of motor development (see Section 6) or even in adults, for example, during learning of a new tool-use task with the transition from conscious feedback control of the hand based on viewing the movement of the tool-tip to automatized motion of hand and tool experienced as a unified effector (Arbib et al., 2009; Borghi et al., 2013; Iriki et al., 1996). Motor adaptation involves learning processes driven by a sensory prediction error, based on sensory expectations acquired while performing the skill, and has been shown to depend on the integrity of the cerebellum (Diedrichsen et al., 2005; Smith and Shadmehr, 2005).

We propose that in the early phase of motor adaptation, the basal ganglia select a coarse-grained motor pattern within the motor cortex which represents a quick but approximative solution to the new condition. This process may engage both trial-and-error exploratory changes in the behaviour, and cognitive strategies that can direct the search towards a solution. The cerebellum and several cortical regions mainly belonging to the dorsal pathway are critical to signal that it is necessary an adaptation process. The cerebellum updates the perceptual predictions about the sensory consequences of one’s own action. This function is accomplished by comparing internal predictions about the sensory consequences of our own actions with the actual afference encoded by the somatosensory cortex, thereby isolating the afferent component that is externally produced. The cerebellum might mediate the updating of predictions about the sensory consequences of actions, ensuring both precise action performance and truthful perceptual interpretation of external events, including actions (Wolpert et al., 1998). The afference is compared with an internal prediction about the sensory consequences of one’s own action generated by the cortical-cerebellar forward model circuit. The internal prediction is based on signals related to movements, including efference copy of the motor command and sensory information of the state of the body (Wolpert et al., 2003). In case of a match between the internal predictions about the sensory consequences of one’s own actions and afference, the afference can be interpreted as a result of self-action (reafference). In the case of a mismatch between the internal predictions about the sensory consequences of one’s own actions and afference, the difference corresponds to an external sensory event due for example to an unexpected perturbation of the movement. Thus, the mismatch between the internal predictions about the sensory consequences of one’s own actions

and afference might supply a “go signal” to inform the basal ganglia-cortical system that the adaptive process could start to work. Spatial working memory involving prefrontal and parietal areas could be relied upon for processing mismatch information, especially for visuomotor adaptation, to modulate the rate of motor learning for sensorimotor adaptation (Seidler et al., 2012).

Thanks to their capacity to react to the received feedback, basal ganglia can generate the final posture (e.g., through the selection of the motor program within premotor areas) and a gross movement trajectory that bring performance towards the baseline level (Dudman and Krakauer, 2016; Houk et al., 2007). The cerebellum might acquire this solution with supervised learning by using the basal ganglia output as a desired action plan. The thalamo-cortical-cerebellar circuits and the recently discovered connection linking the basal ganglia with the cerebellum, the subthalamic-pons-cerebellar circuit (Bostan et al., 2010), may be useful to convey the information about the desired action plan. The cerebellum might then further refine the movement based on feedback-error corrections. In addition, neural noise may support the finding of the finer solution by allowing a neural exploration among several similar neural patterns located around the gross pattern selected by the basal ganglia (Faisal et al., 2008; Thorp et al., 2017). Performance could thus fully recover towards baseline levels.

These neural mechanisms are supported by substantial empirical data. In this respect, the proposed early involvement of the basal ganglia followed by a subsequent involvement of the cerebellum agrees with data showing that during motor adaptation there is an early activation of the striatal regions followed by an activation of cerebellar areas (Doyon et al., 2003a; Shadmehr and Holcomb, 1999). Similarly, fMRI studies of visuomotor adaptation have reported activation in basal ganglia, premotor, dorsolateral prefrontal and parietal regions during the early stages of adaptation (Anguera et al., 2007; Inoue et al., 1997; Seidler et al., 2006), with late learning activation observed at the cerebellum (Graydon et al., 2005; Miall et al., 2001). PET studies of force-field adaptation demonstrate bilateral activation at the dorsolateral prefrontal cortex and parietal regions early in learning, while later in learning activation shifts towards left premotor and right cerebellar regions (Krebs et al., 1998; Shadmehr and Holcomb, 1997).

Recent evidence shows that inhibition of somatosensory cortex after partial adaptation blocked further adaptation, supporting the critical involvement of this cortical area in sensorimotor adaptation (Mathis et al., 2017). In addition, there is evidence suggesting that dopaminergic signals based on reward could mark the coarse-grained neural patterns (which might for example represent the final goal of a movement) within the basal ganglia, at the same time furnishing a learning signal to the cerebellum (Doya, 2002; Schweighofer et al., 2004). The teaching signal used by the supervised learning mechanism operating in the cerebellum might be given by the combination of the motor noise signal (Thorp et al., 2017) and the dopamine signal (i.e., the reward signal), the latter correlated with the goal of the action (Doya, 2002). This teaching signal might be conveyed by the subthalamic-pontine-cerebellar connection and might modulate the cerebellum’s sensitivity to incoming error signals. In this way, the basal ganglia and the dopaminergic system might drive the cerebellum to update its forward (and perhaps inverse) models based on predicted reward or punishment. This perspective is also supported by recent data showing that cerebellar granule cells encode expected reward (Wagner et al., 2017), and that reward and punishment differentially influence motor adaptation (Galea et al., 2015).

The learning rate of the cerebellum could be modulated by the expected utility of the actions. Hence, playful exploration of a novel environment or novel actions within an environment, driven by action selection in the basal ganglia, could potentially disrupt the internal models within the system formed by the cerebellum, cortex and basal ganglia. The learning rate should be reduced to protect existing motor skills. However, if the novel actions are associated with high reward (or punishment), then the cerebellar learning could be enhanced, to

optimise the execution of these actions. In other words, the basal ganglia would prime the cerebellum to update its forward models based on predicted reward or punishment (Miall and Galea, 2016).

4.2. Supervised and unsupervised learning support reinforcement learning during acquisition of motor sequences

Motor skill learning generally refers to neuronal changes that allow an organism to accomplish a motor task more accurately or faster than before (Diedrichsen and Kornysheva, 2015). In contrast to adaptation, skill learning typically involves the generation of a novel movement pattern, and can be quantified by improvements in accuracy or speed (shifts in the speed-accuracy relationship, (Shmuelof et al., 2012)) in a wide variety of tasks, including, for example, fast sequential finger tapping (Kami et al., 1995), serial reaction time (Willingham, 1998), motor synergy tasks (Waters-Metenier et al., 2014), sequential force control (Reis et al., 2009) and visual tracing (Shmuelof et al., 2012). Among these tasks, motor sequence learning is a well studied representative type of skill learning consisting in the acquisition and optimization of a novel sequences of interrelated movements.

Here, we propose that during the initial phase of motor sequence learning the cerebellum selects fine-granularity neural patterns in the thalamo-motor cortical circuits involving cortical motor areas. These patterns are critical to recall the single movement elements (i.e., the features of the motor acts) already learned and stored in the internal models managed by the cerebello-thalamo-cortical system involving premotor and dorsal-prefrontal areas (Caligiore et al., 2013b; Wolpert et al., 1998). By selection between similar fine-grained patterns, the cerebellum optimises their execution. The well-executed actions lead to reward. Thus, the cerebellum gradually contributes to the involvement of the basal ganglia that, through the cortico-striatal-thalamo-cortical loops, are essential to glue the single motor acts into a sequence, for example a coordinated reaching-grasping sequence, where preshaping occurs as the reach proceeds and the reach slows down as the hand encloses the object (Arbib, 2011). The basal ganglia learn to assemble the motor acts by means of reinforcement learning (Graybiel, 1998). The output of the basal ganglia, indeed, depends on synaptic projections from the cortex to medium spiny neurons in the striatum. These projections are plastic and their efficacy changes depending on dopaminergic inputs from substantia nigra pars compacta, which code the reward prediction error and underlie the reward of the motor act sequence (Frank, 2005; Schultz, 1997).

We suggest that the cerebellum might support this reinforcement learning process by providing the timing information needed from the basal ganglia and cortex to properly combine the motor acts. In more detail, the recently discovered disynaptic connection linking cerebellum with striatum through thalamus, the cerebello-thalamo-striatal pathway (Hoshi et al., 2005), might be important to convey such timing signal to the basal ganglia alongside to information provided to cortex. The cerebellum is essential for proper sensory and motor timing in the range of milliseconds up to a second (Ivry et al., 1988a; Lusk et al., 2016a). The cerebellar granular layer appears especially well-suited for timing operations required to confer millisecond precision for cerebellar computations. This may be most evident in the manner the cerebellum controls the duration of the timing of agonist-antagonist EMG bursts associated with fast goal-directed voluntary movements. In concert with adaptive processes, interactions within the cerebellar cortex are sufficient to support sub-second/second timing. However, supra-second timing seems to require cortical and basal ganglia networks, perhaps operating in concert with cerebellum. Additionally, sensory information such as an unexpected stimulus can be forwarded to the cerebellum via the climbing fiber system, providing a temporally constrained mechanism to adjust ongoing behavior and modify future processing (Bareš et al., 2018b). Multiple lines of evidence have shown striatal involvement in millisecond timing (Merchant et al., 2013; Pastor et al., 2006) and there is increasing evidence supporting its

involvement in durations ranging from seconds-to-minutes (Harrington et al., 2010; Jones and Jahanshahi, 2014; Koch et al., 2009). The striatum likely acts as an integrator capable of detecting specific durations based on cortical oscillation patterns (Allman and Meck, 2011; Meck and Malapani, 2004; Miall, 1989; Yin et al., 2016). The cerebellum timing mechanisms feed into these striatal-thalamo-cortical circuits, with an expertise that allows for error correction and priming of the striatal system (Schwartz et al., 2016). In this way, the cerebellum could reduce variability, through the detection of stimulus onsets and the sub-division of longer durations, thus contributing to both sub-second and supra-second timing. This sensitivity of the cerebellum to stimulus dynamics and subsequent integration with motor control allows it to accurately measure intervals within a range of 100–2000 ms. For intervals in the supra-second range (e.g., > 2000 ms), the cerebellar output signals from the dentate nucleus pass through thalamic connections to the striatum, where cortico-thalamic-striatal circuits supporting higher-level cognitive functions take over (Petter et al., 2016b). As a task is learned the need for motor and temporal adjustments decreases as does the reliance on the cerebellum. In line with models for sequential motor learning (Doyon et al., 2009), one could posit that if the same sequence analogous to ‘duration-based’ timing was presented multiple times, cerebellum activity would gradually decrease as the temporal sequence is learned and timing responsibility is shifted to the striatum. This view is in line with the timing hypothesis of cerebellar function discussed in Section 3. Moreover, the results of recent experiments in mice conducted by Chen and colleagues further support our hypothesis. The authors show that the cerebellum rapidly modulates the activity of the striatum via the cerebello-thalamo-striatal pathway. Under physiological conditions this short latency pathway is capable of facilitating optimal motor control by allowing the basal ganglia to incorporate time-sensitive cerebellar information and by guiding the sign of cortico-striatal plasticity (Chen et al., 2014).

Along the cerebello-thalamo-striatal and the cerebello-thalamo-cortical pathways, the cerebellum might work as a supervisor supplying a signal that might contribute to scheduling the salient learning events (e.g., to switch between two motor acts), improving the effectiveness of the dopamine signal during reinforcement learning. This hypothesis is in line with some machine learning proposals about possible interaction between supervised and reinforcement learning mechanisms where the supervisor supplies an additional source of information that essentially simplifies the task faced by the reinforcement learning system (Barto and Dietterich, 2004; Barto and Rosenstein, 2004). Driven by the timing signal supplied by the cerebellum and by the reward signal supplied by the dopamine input, the basal ganglia learn to select gross thalamo-cortical neural patterns corresponding to group of motor acts combined in a sequence.

This perspective agrees with several data collected in humans and animals and showing that managing of action sequences learning and performing involve cortical areas working in concert with cerebellum and basal ganglia (Cattaneo et al., 2011; Jin et al., 2014; Penhune and Steele, 2012; Tanji, 2001). Doyon and colleagues used fMRI during motor sequence learning paradigm in humans to show an experience-dependent shift of activation from the cerebellar cortex to the dentate nucleus during early learning, and from a cerebellar-cortical to a striatal-cortical network with extended practice (Doyon et al., 2002). Similar data has been found in experiments with monkeys (Graybiel, 1995; Miyachi et al., 2002) where it has been also shown that after extensive training on motor sequence tasks, neurons in the vicinity of supplementary motor area, SMA, come to represent those sequences (Tanji, 2001). Different neurons in pre-supplementary motor area (pre-SMA) and in SMA contribute to encoding the conditional links between the previous and the upcoming actions as well as where in a sequence the action is (Nachev et al., 2008). The cerebellum, which is anatomically linked to both pre-SMA and SMA through the thalamus (Akkal et al., 2007), could assist these cortical areas by supporting the anticipatory activation of their cells during learning and performing of

action sequences. In particular, the cerebellum might support pre-SMA and SMA to acquire the capacity of anticipating future events at fast temporal scales based on forward models (Caligiore et al., 2016b, 2013b; Strick et al., 2009). SMA and pre-SMA are also linked with the basal ganglia subthalamic nucleus through the hyperdirect pathway. This pathway conveys the signal from motor-related cortical areas (in this case pre-SMA and SMA) to the globus pallidus, bypassing the striatum, with shorter conduction time than the signal conveyed through the striatum (Nambu et al., 2002). Through this pathway, the activation of pre-SMA and SMA neurons could regulate, in an anticipatory fashion with respect to the next movement, the activation of the subthalamic nucleus. The anticipatory activation of the subthalamic nucleus could, in turn, support the anticipatory activation of the next movement of the sequence by fostering the movement selection processes through the direct pathway of the basal ganglia (Gurney et al., 2001) thus favouring the concatenation of motor acts into sequences.

Unsupervised learning processes, based on the action of neuromodulators acting at cortical level, might also contribute to consolidate the connection between different neural patterns (i.e., different motor acts) sequentially activated during action execution (Fonollosa et al., 2015; Nambu et al., 2002). In more detail, it has been shown that acetylcholine and noradrenaline could contribute to shifting the dynamics of cortical activation of neural pattern from the influence of external stimulation to a predominant influence of intrinsic activity (Hasselmo, 1995). This evidence suggests that the action of acetylcholine and noradrenaline might be important to schedule the sequence of motor acts by distinguishing movements mainly triggered by external stimuli from the environment from those mainly caused by other motor acts within the sequence. Similarly, serotonin, which controls the balance between short-term and long-term prediction of reward (Doya, 2002), might support motor sequence learning by regulating the balance between the learning signal necessary to connect two subsequent motor acts (short-term prediction of reward) and the learning covering the whole motor sequence (long-term prediction of reward).

Fig. 5 summarises some key neural and neuromodulation processes involved in super-learning that involve the interplay and reciprocal influence of unsupervised, supervised, and reinforcement learning processes.

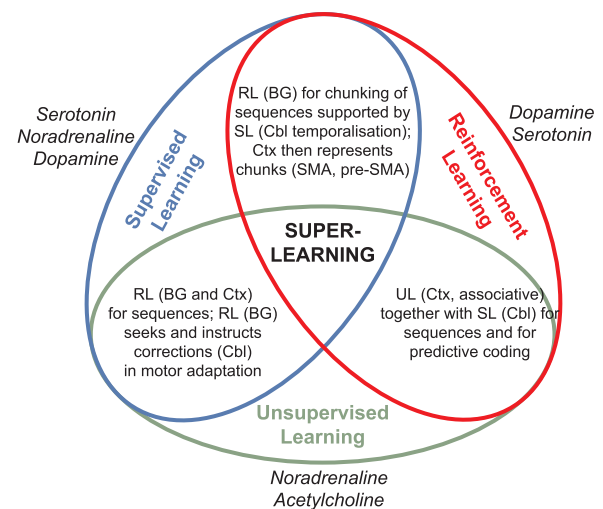

Fig. 5. Interplay of super-learning neural mechanisms (coloured text and ovals) considered in this work. These processes involve several brain areas and computational mechanisms (black text), and diverse neuromodulators supporting them (black text in *Italics*). Ctx: cortex; BG: basal ganglia; Cbl: cerebellum. SL, UL, RL: supervised, unsupervised, and reinforcement learning, respectively.

5. Evidence relevant to refining the super-learning hypothesis

5.1. Cerebellum and basal ganglia: interactions between supervised and reinforcement learning

An increasing number of researchers have started to investigate how unsupervised, supervised and reinforcement learning processes may work through parallel and interacting mechanisms operating in specific cortical, cerebellar and basal ganglia areas. Several works support the involvement of cerebellum in reinforcement learning processes. Experiments with animals show that in classical conditioning tasks (i.e., reinforcement learning tasks) the inferior olive, which conveys signals to the cerebellum to regulate motor coordination and learning, is engaged early in the learning process and habituates as task performance improves, increasing activity only in the instance of performance errors. In this way, the inferior olive serves as an evaluative feedback mechanism to promote optimal performance for maximum reinforcement (Thompson and Steinmetz, 2009 for a review). Bauer and colleagues show that lesions of the dentate nucleus in rats (a cerebellar output nucleus) reduce motivation, resulting in depressed responding for appetitive reward (Bauer et al., 2011). Similar data has been found in humans where focal cerebellar lesions selectively impair reward-based reversal learning in an associative learning paradigm (Thoma et al., 2008). Building on the results of their experiments with monkeys involved in motor sequence learning, Hikosaka and colleagues proposed that learning of kinematics and dynamics aspect of motor sequence proceeds in parallel, but have different times courses and are controlled by different cortico-striatal and cortico-cerebellar loop circuits. The kinematic component, expressed in terms of accuracy, is learned more quickly. This component is dependent on circuits linking frontal, parietal and premotor regions with caudate and lateral cerebellar association areas. By contrast, the dynamic component, expressed in terms of changes in speed and other motor parameters, occurs more slowly. Learning of this component is controlled by circuits linking motor cortical regions with the putamen and midline cerebellar regions. In addition, they propose that reward-based learning involving cortico-striatal circuits and error-based learning involving cortico-cerebellar loops would contribute to shaping these processes (Hikosaka et al., 2002, 1995; Lu et al., 1998).

Several authors have also investigated the relationship between supervised and reinforcement learning mechanisms by studying the interplay between two forms of prediction error produced within the brain by comparing predicted and observed consequences of motor commands: the *sensory prediction error* computed as the difference between the effective and predicted sensory feedback (observed in terms of activity in primary sensory organs, e.g., touch, vision or proprioception); the *reward prediction error* calculated as the difference between the expected value of an action (in terms of its utility or usefulness) and the value achieved. Supervised learning processes mainly pivot on the minimization of sensory prediction errors while reinforcement learning processes are mainly based on the minimization of the reward prediction error. Izawa and Shadmehr studied the interplay between the two forms of prediction error in a reach adaptation protocol, which is the form of supervised learning that has been studied most extensively. They found that when high-quality sensory feedback is available, adaptation of motor commands is driven almost exclusively by sensory prediction errors (i.e., by supervised learning mechanisms). In contrast, as the quality of the sensory feedback degrades, adaptation of motor commands become more dependent on reward prediction errors (i.e., by reinforcement learning processes). In another study, Izawa and colleagues compared performance of cerebellar patients and healthy controls in a reaching task with a gradual perturbation schedule. The results of the experiment show that cerebellar subjects can counter a gradual visuomotor rotation and generalize the new reach pattern to other targets when they learn with concurrent sensory feedback (online visual cursor feedback) and binary reward feedback. The authors

suggest that cerebellar patients rely on a reinforcement mechanism because they did not change the perceived location of their hand in a proprioceptive recalibration test (Izawa et al., 2012). Such proprioceptive recalibration is thought to be a hallmark of sensory prediction error-based adaptation tasks (Synofzik et al., 2008). It is however also possible that these results are based on complex interactions among systems, for example reinforcement learning processes might indirectly affect cerebellum learning by biasing attention which in turn might lead to repetition and associative learning. In this line, Tan and colleagues show that post-movement beta activity (13–30 Hz) over sensorimotor cortex-basal ganglia network in healthy subjects relates with the evaluation of uncertainty in feedforward estimation. The authors suggest that the amplitude of this activity signals the need for maintenance or adaptation of the motor output, and if necessary, exploration to identify an altered sensorimotor transformation. These results suggest that the prediction error signals in the basal ganglia during motor adaptation are dependent on reliability (Tan et al., 2016).

Recently, Therrien and colleagues proposed that cerebellar damage indirectly impairs reinforcement learning by increasing motor noise. The authors devised two experiments with participants involved in an error-based adaptation task. The first experiment involved healthy young adults, the second one involved patients with cerebellar damage and age-matched controls. In both cases, the participants either received error-based feedback (a cursor feedback) or a binary reward signal (i.e., success or failure) at the end of a reaching movement, indicating good performance if they reached a position close to the target. The authors found that participants with cerebellar damage and healthy controls show learning under both error-based and reward feedback conditions (Therrien et al., 2016). Interestingly, the normal learning with error feedback in the cerebellar group is inconsistent with the proposals in which supervised learning based on error feedback are the exclusive responsibility of the cerebellum (Doya, 2000, 1999). However, cerebellar patients varied in their learning performance in the reinforcement condition, with some showing only partial learning ability. The authors developed a computational model of the reinforcement condition and used it to show that learning could be dependent on the balance between motor noise and exploration variability. In Therrien's study, the patient group had greater motor noise and hence learned less. The authors also found that the reward feedback led to optimal retention of the learned behaviour during a post-learning test phase, whereas the error feedback learning was not retained, and decayed in the test phase. These results agree with previous findings showing that in the absence of error feedback adapted behavior can be stabilized by binary reward feedback (Shmuelof et al., 2012).

5.2. Basal ganglia and cortex: interactions between reinforcement and unsupervised learning

The influence of reward-based processes operating in the basal ganglia in unsupervised learning has been recently studied by Wong and colleagues (Wong et al., 2013). The authors showed that basal ganglia activity can affect unsupervised learning processes during a spatial learning task where the participants develop internal representations of the environment through self-exploration without explicit feedback or instruction. In particular, they examined whether intrinsic fluctuations of resting-state functional magnetic resonance imaging (rsfMRI) signal in the basal ganglia can be used to predict the participant's ability to learn in a virtual-reality unsupervised spatial learning environment. The results show that better performers have higher rsfMRI signal amplitudes in the basal ganglia. In this line, it has been recently suggested that cortical networks on their own may also support reinforcement learning (Wang et al., 2018). Kim and colleagues proposed a computational model of the basal ganglia-cortical system showing that motor adaptation could involve cortical Hebbian learning mechanisms with basal ganglia that modulate the activity of thalamo-

cortical relay neurons based on reinforcement learning mechanisms pivoting on dopaminergic signals (Kim et al., 2017). Bar-Gad and colleagues proposed that the functions implemented by basal ganglia involve dimensionality reduction (i.e., the compression of extended cortical neural patterns into small neural codes), and that interaction between reinforcement and unsupervised learning mechanisms might support it (Bar-Gad et al., 2003). This idea is also supported by anatomy showing a high convergence of cortical connections into the relatively small striatum nuclei (Feingold et al., 1996). Pivoting on this perspective, Bonaiuto and Arbib proposed a neurorobotic model that uses a modulation of cortical learning by a reinforcement signal in order to extract combinations of object features that afford successful grasps (affordances) (Bonaiuto and Arbib, 2015). Mannella and Baldassarre proposed a neural model showing how in some conditions unsupervised learning processes acting within basal ganglia are sufficient to support the selection of different thalamo-cortical dynamical patterns supporting the acquisition of multiple variants of very different motor patterns (Mannella and Baldassarre, 2015). The computational model proposed by Ashby and colleagues suggests that the subcortical pathways projecting to the premotor area via the striatum, globus pallidus, and thalamus has greater neural plasticity because of a dopamine-mediated learning signal from the substantia nigra. In contrast, the cortical-cortical path learns more slowly via (dopamine independent) Hebbian learning. Because of its greater plasticity, early performance is dominated by the subcortical path, but the development of automaticity is characterized by a transfer of control to the faster cortical-cortical projection (Ashby et al., 2007).

5.3. Cerebellum and cortex: interactions between supervised and unsupervised learning

Spampinato and Celnik use non-invasive brain stimulation to explore cerebellar and primary motor cortical mechanisms during early and late motor skill learning in humans. Their findings indicate that early in motor skill learning, cerebellar-dependent learning mechanisms (i.e. error-based processes) are needed to learn the task dynamics before the primary motor cortex, incorporating other forms of learning (i.e. reward-based or use-dependent), is engaged. These findings indicate a distinct temporal dissociation in the physiological role of the cerebellum and cortex when learning a novel skill (Spampinato and Celnik, 2017).

Based on anatomical and physiological data supporting cerebro-cerebellar interactions, Molinari and colleagues propose that the cerebellum could control cortical plastic changes by modulating cortical excitability in a discrete topographic manner and that this mechanism could induce the coupling between specific sensory inputs and motor outputs (Molinari et al., 2002). The organization of cerebellum in microcomplexes, each comprising a set of Purkinje cells and neurons in the cerebellar nuclei, and the long length of the parallel fibers overlapping different coupling of microcomplexes (Arbib et al., 1995) support this mechanism. Similarly, Kishore and colleagues note that cerebellar cortical excitation leads to an enhancement of the normal inhibition of dentate nucleus by the Purkinje cells. This reduces the normal excitatory control of dentate nucleus on the afferent inflow to primary motor cortex, thus, they suggest, blocking the sensorimotor-plasticity within it. The authors suggest that the functional relevance of such cerebellar modulation of cortical plasticity could be to prevent the selection of unsuited or new motor programs by sources external to the cortex and to provide stability to motor maps (Kishore et al., 2014). From a computational perspective, a modern view of the function of the cortex is building on probabilistic models able to predict sensory inputs (Friston, 2010). Such models can not only build representations, but also predict one modality, e.g. an auditory representation, on the basis of the other modality, e.g. visual input. In this way, the cortex can perform also supervised learning, if an “input pattern” is presented to one modality, while the “output pattern” to the other modality

(O’Reilly and Munakata, 2000). Within this line, a lot of papers have been recently published suggesting how during such associative learning the cortical networks can approximate the back-propagation algorithm, which is a very effective algorithm for supervised learning (for review see Whittington and Bogacz, 2019).

Finally, Schweighofer and colleagues proposed a bio-inspired computational model to study how unsupervised learning mechanisms could boost the cerebellar supervised learning performance. They argued that cerebellar motor learning is enhanced by a sparse code (i.e. a neural code in which the fraction of active neurons is low at each time) that simultaneously maximizes information transfer between mossy fibers and granule cells, minimizes redundancies between granule cell discharges, and re-codes the mossy fibers inputs with an adaptive resolution such that inputs corresponding to large errors are finely encoded. The authors propose a set of physiologically plausible unsupervised learning rules that might operate within the cerebellar cortex to produce such a code (Schweighofer et al., 2001). They show that unsupervised learning of granule cell sparse codes greatly improves adaptive motor control producing fast, accurate and stable learning in comparison to traditional cerebellar models where these mechanisms are not considered.

6. Super-learning addresses some open issues

This section discusses how the super-learning hypothesis can help to deal with some open issues in motor learning research.

6.1. What are the differences and commonalities of early motor learning and adaptation?

While motor adaptation considered here is much studied as it involves the modification of existing motor skills in the presence of changes that can be produced in the lab, the initial acquisition of most basic motor skills takes place at an early developmental age and so poses difficulties to the study of its underlying neural processes. Behaviourally, the development of basic movements, for example for reaching and grasping (Bonaiuto and Arbib, 2015; Caligiore and Baldassarre, 2018; Oztop et al., 2004), is studied in early infancy in developmental-psychology longitudinal experiments (Berthier and Keen, 2006; Carlson and Harris, 1985). It has been proposed with computational models that these acquisition processes involve trial-and-error learning mechanisms (see (Caligiore et al., 2014), for a review and a model). How does super learning relates to these studies? These studies show that early motor learning, for example involving reaching, builds on the performance of distinctive “sub-movements” detectable as multiple acceleration-deceleration phases of the whole movement (Berthier and Keen, 2006; Carlson and Harris, 1985). In different stages of development, sub-movements progressively decrease in number until they lead to a single harmonious movement. Sub-movements have been ascribed to motor noise and the active attempts to correct the movement trajectory based on the feedback on the accomplishment of the desired target (Berthier and Keen, 2006; Caligiore et al., 2014).

The presence of sub-movements is predicted by the super-learning hypothesis stating that when facing a new motor challenge basal ganglia initially search coarse-grained solutions to it. The information acquired by trial-and-error is progressively transferred to the cortical-cerebellar system, forming an internal model, which is acquired on the basis of “supervised associative processes” under the initial “instruction” (supervision) by the basal ganglia. This view is supported by empirical evidence showing that when behaviour is first acquired and then automatized (becoming “habitual”) the basal ganglia show a high initial activation that then decreases with the progress of learning (Ashby et al., 2010). However, the super-learning also states that the refinement of movements also involves the fine-grained operation of cerebellum. Indeed, we have seen that empirical data on motor

adaptation support this view. The difference with motor learning, justifying its faster course, might be that adaptation can also rely on internal models that furnish information on “what to expect” usable for supervised (re-)learning. The super-learning hypothesis thus proposes an integrated view of initial learning and later adaptation, and hence a basis to empirically investigate the mechanisms they share or possess exclusively.

6.2. Why does the striatum activate before cerebellum during motor adaptation?

During motor adaptation, one typically sees striatal activation during the early phase of learning and more prominent cerebellar activation during the later acquisition process (Doyon et al., 2003a; Shadmehr and Holcomb, 1999). These findings have suggested that, in contrast to motor sequence learning, during motor adaptation there is a transfer of plasticity from a striatal-cortical to a cerebellar-cortical network. At present, however, the mechanisms underlying this transfer need to be explained and supported by further theoretical and empirical research (Doyon et al., 2002).

According to the super-learning mechanisms described in Section 4.1 the early striatal activation might be necessary to allow the basal ganglia to select a gross motor pattern within the motor cortex, representing a quick solution to the perturbed motor task. The cerebellum could subsequently work on this gross solution to gradually improve it through a transfer of plasticity from a striatal-cortical to a cerebellar-cortical network. In this way, the subject can gradually recover the baseline level of performance.

6.3. What does fine regulation of learning processes in the granule cells depend on?

It is still not fully clear how the activation of specific granule cells during LTP and LTD processes in the cerebellum contribute to the fine tuning of motor behaviour (D'Angelo and De Zeeuw, 2009). The super-learning mechanisms described above suggest that the neuromodulatory system might contribute to this tuning. In particular, the subthalamic-pons-cerebellar circuit might make specific granule cells sensitive to dopamine reward signals to boost their activation during LTP/LTD processes. Wagner and colleagues have recently reported substantial reward-related signals in the granule cell activity (Wagner et al., 2017). As we have seen in Section 3, a fine regulation of the granule cells activation may be important to drive, in turn, the recruitment of cerebellar microcomplexes during learning of fine-granularity neural patterns selection. The recruitment of cerebellar microcomplexes might also be modulated by the action of another neuromodulator, the serotonin, which might contribute to driving the responsibility of each cerebellar microcomplex during these learning processes (Schweighofer et al., 2004).

6.4. What is the encoding of sensorimotor parameters in cerebellar internal models?

We have seen that motor control relies on internal models, i.e. forward models predicting the effects of action in the current state, and inverse models producing the action to achieve a goal from a starting state. It is widely accepted that the cerebellum is a critical part of the cortical-subcortical system involved in the acquisition and use of internal models (Wolpert et al., 1998). A key open issue highlighted by recent literature on motor learning regards the identification of the sensorimotor parameters encoded by the cerebellar internal models. This would require experiments examining cerebellar contributions to learning-related changes in movement parameters such as force, velocity, timing and coarticulation. Some experiments related to this have been conducted in animals, but relatively few have been carried out with humans (Penhune and Steele, 2012).

In agreement with the super-learning mechanisms, the cerebellum might manage the sensorimotor parameters represented by the cerebellar internal models through the fine-granularity selection of neural patterns within the thalamo-cortical circuits. In more detail, the fine regulation of the granule cells activation due to the dopamine signal activate a subset of Purkinje cells that, in turn, modulate a group of cerebellar nucleus. This group regulates the parameters of a motor pattern generator outside the cerebellum (Arbib and Spelstra, 1997), which may be located in spinal cord, midbrain, or even cerebral cortex and this regulation might affect an elemental movement by producing changes in movement parameters such as force, velocity, timing and coarticulation (Ito, 2013).

6.5. What are the mechanisms underlying the managing of different cortical time-scales during action sequences?

During the production and learning of action sequences, it is still not clear how the brain manages the huge gap of time scales between the response of single neurons, which is on the order of tens of milliseconds, and common behaviors, which usually span several seconds and minutes. To address these issues, it has been proposed that the organization of cortical anatomy might reflect the temporal hierarchy that is inherent in the dynamics of environmental states (Baldassarre et al., 2013; Kiebel et al., 2008). According to this perspective, the lowest level of this hierarchy corresponds to fast information processing involving, for example, somatosensory and primary motor information processing below the second. Premotor/supplementary motor levels support motor preparation and sequences in the range of seconds. And finally the highest levels involving prefrontal regions encode slow contextual changes in the environment under which faster representations unfold. This hierarchical organization depends on forward and backward connections within the cortical regions. Backward connections, targeting NMDA receptors in the supra-granular layers, tend to produce a modulatory effects on neuronal responses (Sherman and Guillery, 1998), and show synaptic dynamics having slower time constants (Sherman, 2007). This suggests that forward connections elicit an obligatory response in higher levels, whereas backward connections have modulatory effects and operate over greater spatial and temporal scales (Kiebel et al., 2008).

The cortical-subcortical interactions underlying super-learning could have a critical role in these issues. Both basal ganglia and cerebellum, indeed, form anatomical loops with lower and higher levels of this cortical hierarchy and might support the managing of timing issues in different ways (Section 3). As we have seen, basal ganglia might contribute to select thalamo-cortical neural patterns at the different levels of the hierarchy on the basis of their partially specialised macro-loops involving the putamen/caudate/accumbens portions of striatum (Mannella and Baldassarre, 2015; Yin and Knowlton, 2006). Regarding the higher levels of the hierarchy, empirical evidence shows that the synapse-specific differences in striatal NMDA receptor content could differentially modulate the signal transmission in the basal ganglia-thalamo-cortical circuits (Sil'kis, 2003; Smeal et al., 2008). This modulation might support the work of the backward cortical connections targeting NMDA receptors and operating over greater spatial and temporal scales. Conversely, the cerebellum might mainly contribute to the functioning of the lower levels of the cortical hierarchy, those related to the regulation of the fast fluctuations of sensorimotor processing. In particular, the cerebellum might be involved in the fast computation of the sensory prediction error that should alter the internal models that predict the sensory consequences of motor commands (Chen et al., 2014; DeLong and Strick, 1974; Edelman, 2001). Although basal ganglia and cerebellar neural networks have a degree of specialization, accurate and precise timing likely requires that both systems act as a cohesive unit (Doyon et al., 2003b; Muller and Nobre, 2014; Teki et al., 2011). In this respect, the high degree of connectivity and the hierarchical organization that exists between the cerebello-thalamo-

cortical and the cortico-striato-thalamo-cortical loops suggests that these neural networks work in conjunction across both sub- and supra-second time scales as a unified entity. Several lines of evidence indicate that the cerebellar system could be principally involved in initiation of the timing process and adjustment during acquisition of tasks (Lusk et al., 2016b; Petter et al., 2016c). Adjustment refers to the modulation of on-going neural processes in order to decrease variability through error correction mechanisms. By contrast, the striato-thalamo-cortical network could be more involved in the continuation and termination phases of timing, where continuation refers to mechanisms associated with tracking or accumulating the passage of time during intervals where external stimuli are absent or constant, and termination refers to the discontinuation of temporal processing following the off-set of the stimulus being timed or the presentation of an explicit ‘stop’ signal (Petter et al., 2016d). Although there are clear neurophysiological distinctions between the striatum and cerebellum in sub- vs. supra-second timing (cf., Section 4), the differentiation in temporal mechanisms may additionally depend by the task at hand. Each circuit may play a role in temporal initiation depending on whether explicit or implicit timing mechanisms are being used. Furthermore, the degree to which external cues can be used to help increase temporal precision throughout the interval being timed may be reflected in the degree of activation in the cerebellar and striato-thalamo-cortical pathways.

There is still much work to be done in order to fully understand the connectivity between certain areas thought to be essential in timing. Implementation of optogenetics stimulation using retrograde viral vectors paired with recording techniques will be invaluable in further elucidating network interactions. Simultaneous in vivo recordings from both the cerebellum and striatum will also be essential in determining how communication between these regions allows organisms to modulate internal timing mechanisms. Specifically, simultaneous recordings in the striatum as well as the cerebellum, SMA or other cortical areas would prove informative (Gu et al., 2011; Schirmer et al., 2016).

7. Conclusions

In this article, we discussed how the interaction between cortex, cerebellum and basal ganglia might produce a *super-learning mechanism* that, by integrating unsupervised, supervised and reinforcement learning mechanisms, supports the acquisition of flexible motor behaviour. We considered empirical evidence supporting this hypothesis and proposed specific mechanisms related to the dynamical interplay between these different forms of learning during motor sequential learning and motor adaptation.

Our proposal could be extendable to learning processes involving different domains, including the solution of cognitive tasks, since the neural mechanisms underlying super-learning are applicable to neural pattern formation in general. This latter claim is in line with increasing evidence supporting the involvement of basal ganglia and cerebellum in non-motor functions (Caligiore et al., 2016b; Kotz et al., 2009; Strick et al., 2009). Higher-level functions of the cortex are expressed through its interactions with “lower level” systems which, in turn, are critical in modulating cortical functions (Kozioł and Budding, 2009). For example, it has been proposed that the hierarchical organization and interaction between basal ganglia and cortical structures underlines a hybrid unsupervised and reinforcement learning algorithm that can perform a number of distinct high-level operations, including classification, object and feature localization, and hierarchical memory organization (Ashby et al., 2005; Chandrashekar and Granger, 2011; O’Reilly and Frank, 2006). Furthermore, based on evidence demonstrating an effective connectivity between basal ganglia, cerebellum and cortical regions involved in phonological processing (i.e. left inferior frontal gyrus and left lateral temporal cortex), it has been suggested that in decision making basal ganglia engage in cortical initiation while the cerebellum amplifies and refines this signal (Booth et al., 2007). In the same line, building on the data showing the critical role of the cortical-cerebellar

network for managing predictive mechanisms during language processing (Lesage et al., 2012) and on activation at finer spatial and temporal granularity within the cerebello-thalamo-cortical circuits (Ivry et al., 1988b; Lusk et al., 2016c), it has been proposed that this circuit could be important to accurately discriminate phonemic and syllabic contrasts. These, in turn, are essential to the development of speech perception (Ackermann et al., 2004; Vias and Dick, 2017).

Future versions of the super-learning hypothesis may focus on the neural processes underlying the interactions of key brain areas important to manage the relationship between episodic and procedural memory learning such as amygdala, hippocampus, thalamus, and prefrontal cortex (Arbib and Bonaiuto, 2012; Franklin and Grossberg, 2017). For example, the circuits linking hippocampus and the cerebellum which mediate recently acquired memory, and the circuits including the medial prefrontal cortex and the cerebellum, important to manage remotely acquired memories (Grossberg and Kishnan, 2018), or the neural mechanisms according to acetylcholine, projecting to cortex, amygdala, hippocampus and thalamus, controls the balance between memory storage and memory update (Doya, 2002).

The hypothesis discussed in this paper is in line with the *system-level approach* to the study of brain according to which different classes of behaviours are generated by the interplay of different subsets of components of the nervous system rather than by specific components in isolation (Arbib and Bonaiuto, 2016; Caligiore et al., 2016b, 2010; Caligiore and Fischer, 2013). We have recently shown how using a system-level approach could be crucial to explaining in radically new ways the origin of different dysfunctions of the cortical-cerebellar-basal ganglia system related to Parkinson’s disease (Caligiore et al., 2016a) and Tourette’s syndrome (Caligiore et al., 2017). Similarly, in this article we have discussed how pivoting on the super-learning hypothesis, which is a system-level hypothesis, could advance the study of motor learning in light of a new, more integrated perspective.

Acknowledgements

G.B.’s contribution was supported in part by the EU FET Open project GOAL-Robots - Goal-based Open-ended Autonomous Learning Robots n. 713010; M.A.A.’s contribution was supported in part by the National Science Foundation under Grant No. BCS-1343544 “INSPIRE Track 1: Action, Vision and Language, and their Brain Mechanisms in Evolutionary Relationship.”

References

- Abbott, L.F., Nelson, S.B., 2000. Synaptic plasticity: taming the beast. *Nat. Neurosci.* 3 (Suppl), 1178–1183.
- Ackermann, H., Mathiak, K., Ivry, R.B., 2004. Temporal organization of “Internal speech” as a basis for cerebellar modulation of cognitive functions. *Behav. Cogn. Neurosci. Rev.* 3, 14–22.
- Akkal, D., Dum, R.P., Strick, P.L., 2007. Supplementary motor area and presupplementary motor area: targets of basal ganglia and cerebellar output. *J. Neurosci.* 27, 10659–10673.
- Albus, J.S., 1971. A theory of cerebellar function. *Math. Biosci.* 10, 25–61.
- Alexander, G.E., DeLong, M.R., Strick, P.L., 1986. Parallel organization of functionally segregated circuits linking basal ganglia and cortex. *Annu. Rev. Neurosci.* 9, 357–381.
- Allman, M.J., Meck, W.H., 2011. Pathophysiological distortions in time perception and timed performance. *Brain* 135, 656–677.
- Anguera, J.A., Russell, C.A., Noll, D.C., Seidler, R.D., 2007. Neural correlates associated with intermanual transfer of sensorimotor adaptation. *Brain Res.* 1185, 136–151.
- Arbib, M.A., 2011. Perceptual structures and distributed motor control. *Compr. Physiol.*
- Arbib, M.A., Bonaiuto, J.J., 2012. Multiple levels of spatial organization: world graphs and spatial difference learning. *Adapt. Behav.* 20, 287–303.
- Arbib, M.A., Bonaiuto, J.J., 2016. *From Neuron to Cognition via Computational Neuroscience*. MIT Press.
- Arbib, M.A., Spoelstra, J., 1997. Microcomplexes: the basic unit of the cerebellar role in adaptive motor control. *Behav. Brain Sci.* 20. <https://doi.org/10.1017/s0140525x97221436>.
- Arbib, M.A., Schweighofer, N., Thach, W.T., 1995. Chapter 2 modeling the cerebellum: from adaptation to coordination. *Advances in Psychology*. pp. 11–36.
- Arbib, M.A., Bonaiuto, J.B., Jacobs, S., Frey, S.H., 2009. Tool use and the distalization of the end-effector. *Psychol. Res.* 73, 441–462.
- Artola, A., Bröcher, S., Singer, W., 1990. Different voltage-dependent thresholds for inducing long-term depression and long-term potentiation in slices of rat visual cortex.

- Nature 347, 69–72.
- Ashby, F.G., Gregory Ashby, F., Ell, S.W., Valentin, V.V., Casale, M.B., 2005. FROST: a distributed neurocomputational model of working memory maintenance. *J. Cogn. Neurosci.* 17, 1728–1743.
- Ashby, F.G., Ennis, J.M., Spiering, B.J., 2007. A neurobiological theory of automaticity in perceptual categorization. *Psychol. Rev.* 114, 632–656.
- Ashby, F.G., Turner, B.O., Horvitz, J.C., 2010. Cortical and basal ganglia contributions to habit learning and automaticity. *Trends Cogn. Sci.* 14, 208–215.
- Baldassarre, G., Mirolli, M., 2013. *Intrinsically Motivated Learning in Natural and Artificial Systems*. Springer Science & Business Media.
- Baldassarre, G., Caligiore, D., Mannella, F., 2013. The Hierarchical Organisation of Cortical and Basal-Ganglia Systems: A Computationally-Informed Review and Integrated Hypothesis. *Computational and Robotic Models of the Hierarchical Organization of Behavior*, pp. 237–270.
- Bareš, M., Apps, R., Avanzino, L., Breska, A., D'Angelo, E., Filip, P., Gerwig, M., Ivry, R.B., Lawrenson, C.L., Louis, E.D., Lusk, N.A., Manto, M., Meck, W.H., Mitoma, H., Petter, E.A., 2018a. Consensus paper: decoding the contributions of the cerebellum as a time machine. From neurons to clinical applications. *Cerebellum*. <https://doi.org/10.1007/s12311-018-0979-5>.
- Bareš, M., Apps, R., Avanzino, L., Breska, A., D'Angelo, E., Filip, P., Gerwig, M., Ivry, R.B., Lawrenson, C.L., Louis, E.D., Lusk, N.A., Manto, M., Meck, W.H., Mitoma, H., Petter, E.A., 2018b. Consensus paper: decoding the contributions of the cerebellum as a time machine. From neurons to clinical applications. *Cerebellum*. <https://doi.org/10.1007/s12311-018-0979-5>.
- Bar-Gad, I., Morris, G., Bergman, H., 2003. Information processing, dimensionality reduction and reinforcement learning in the basal ganglia. *Prog. Neurobiol.* 71, 439–473.
- Barto, A.G., Dietterich, T.G., 2004. Reinforcement learning and its relationship to supervised learning. In: Si, J., Barto, A.G., Powell, W.B., Wunsch, D. (Eds.), *Handbook of Learning and Approximate Dynamic Programming*. Wiley-IEEE Press, Piscataway, NJ, pp. 47–64.
- Barto, A.G., Rosenstein, M.T., 2004. Supervised actor-critic reinforcement learning. In: Si, J., Barto, A.G., Powell, W.B., Wunsch, D. (Eds.), *Handbook of Learning and Approximate Dynamic Programming*. Wiley-IEEE Press, Piscataway, NJ, pp. 359–380.
- Bauer, D.J., Kerr, A.L., Swain, R.A., 2011. Cerebellar dentate nuclei lesions reduce motivation in appetitive operant conditioning and open field exploration. *Neurobiol. Learn. Mem.* 95, 166–175.
- Berthier, N.E., Keen, R., 2006. Development of reaching in infancy. *Exp. Brain Res.* 169, 507–518.
- Blatt, G.J., Oblak, A.L., Schmahmann, J.D., 2013. Cerebellar connections with limbic circuits: anatomy and functional implications. *Handbook of the Cerebellum and Cerebellar Disorders*, pp. 479–496.
- Bonaiuto, J., Arbib, M.A., 2015. Learning to grasp and extract affordances: the Integrated Learning of Grasps and Affordances (ILGA) model. *Biol. Cybern.* 109, 639–669.
- Booth, J.R., Wood, L., Lu, D., Houk, J.C., Bitan, T., 2007. The role of the basal ganglia and cerebellum in language processing. *Brain Res.* 1133, 136–144.
- Borghi, A.M., Scorolli, C., Caligiore, D., Baldassarre, G., Tummolini, L., 2013. The embodied mind extended: using words as social tools. *Front. Psychol.* 4, 214.
- Bostan, A.C., Strick, P.L., 2018. The basal ganglia and the cerebellum: nodes in an integrated network. *Nat. Rev. Neurosci.* 19, 338–350.
- Bostan, A.C., Dum, R.P., Strick, P.L., 2010. The basal ganglia communicate with the cerebellum. *Proc. Natl. Acad. Sci.* 107, 8452–8456.
- Botzer, L., Karniel, A., 2013. Feedback and feedforward adaptation to visuomotor delay during reaching and slicing movements. *Eur. J. Neurosci.* 38, 2108–2123.
- Brito, C.S.N., Gerstner, W., 2016. Nonlinear Hebbian learning as a unifying principle in receptive field formation. *PLoS Comput. Biol.* 12 e1005070.
- Caligiore, D., Baldassarre, G., 2018. The development of reaching and grasping: towards an integrated framework based on a critical review of computational and robotic models. In: Corbetta, M., Santello, M. (Eds.), *Reach-to-Grasp Behaviour: Brain, Behaviour, and Modelling across the Life Span*. Routledge, New York.
- Caligiore, D., Fischer, M.H., 2013. Vision, action and language unified through embodiment. *Psychol. Res.* 77, 1–6.
- Caligiore, D., Borghi, A.M., Parisi, D., Baldassarre, G., 2010. TRoPICALS: a computational embodied neuroscience model of compatibility effects. *Psychol. Rev.* 117, 1188–1228.
- Caligiore, D., Borghi, A.M., Parisi, D., Ellis, R., Cangelosi, A., Baldassarre, G., 2013a. How affordances associated with a distractor object affect compatibility effects: a study with the computational model TRoPICALS. *Psychol. Res.* 77, 7–19.
- Caligiore, D., Pezzulo, G., Miall, R.C., Baldassarre, G., 2013b. The contribution of brain sub-cortical loops in the expression and acquisition of action understanding abilities. *Neurosci. Biobehav. Rev.* 37, 2504–2515.
- Caligiore, D., Parisi, D., Baldassarre, G., 2014. Integrating reinforcement learning, equilibrium points, and minimum variance to understand the development of reaching: a computational model. *Psychol. Rev.* 121, 389–421.
- Caligiore, D., Helmich, R.C., Hallett, M., Moustafa, A.A., Timmermann, L., Toni, I., Baldassarre, G., 2016a. Parkinson's disease as a system-level disorder. *NPJ Parkinsons Dis.* 2, 16025.
- Caligiore, D., Pezzulo, G., Baldassarre, G., Bostan, A.C., Strick, P.L., Doya, K., Helmich, R.C., Dirkx, M., Houk, J., Jörntell, H., Lago-Rodriguez, A., Galea, J.M., Chris Miall, R., Popa, T., Kishore, A., Paul, F.M., Zucca, R., Herreros, I., 2016b. Consensus paper: towards a systems-level view of cerebellar function: the interplay between cerebellum, basal ganglia, and cortex. *Cerebellum* 16, 203–229.
- Caligiore, D., Mannella, F., Arbib, M.A., Baldassarre, G., 2017. Dysfunctions of the basal ganglia-cerebellar-thalamo-cortical system produce motor tics in Tourette syndrome. *PLoS Comput. Biol.* 13 e1005395.
- Carlson, D.F., Harris, L.J., 1985. Development of the infant's hand preference for visually directed reaching: preliminary report of a longitudinal study. *Infant Ment. Health J.* 6, 158–174.
- Cattaneo, L., Fasanelli, M., Andreatta, O., Bonifati, D.M., Barchiesi, G., Caruana, F., 2011. Your actions in my cerebellum: subclinical deficits in action observation in patients with unilateral chronic cerebellar stroke. *Cerebellum* 11, 264–271.
- Chandrashekar, A., Granger, R., 2011. Derivation of a novel efficient supervised learning algorithm from cortical-subcortical loops. *Front. Comput. Neurosci.* 5, 50.
- Chen, C.H., Fremont, R., Arteaga-Bracho, E.E., Khodakhah, K., 2014. Short latency cerebellar modulation of the basal ganglia. *Nat. Neurosci.* 17, 1767–1775.
- Chevalier, G., Deniau, J.M., 1990. Disinhibition as a basic process in the expression of striatal functions. *Trends Neurosci.* 13, 277–280.
- Churchland, M.M., Cunningham, J.P., Kaufman, M.T., Foster, J.D., Nuyujukian, P., Ryu, S.I., Shenoy, K.V., 2012. Neural population dynamics during reaching. *Nature* 487, 51–56.
- Cisek, P., Kalaska, J.F., 2010. Neural mechanisms for interacting with a world full of action choices. *Annu. Rev. Neurosci.* 33, 269–298.
- D'Angelo, E., Casali, S., 2012. Seeking a unified framework for cerebellar function and dysfunction: from circuit operations to cognition. *Front. Neural Circuits* 6, 116.
- D'Angelo, E., De Zeeuw, C.I., 2009. Timing and plasticity in the cerebellum: focus on the granular layer. *Trends Neurosci.* 32, 30–40.
- D'Ardenne, K., Eshel, N., Luka, J., Lenartowicz, A., Nystrom, L.E., Cohen, J.D., 2012. Role of prefrontal cortex and the midbrain dopamine system in working memory updating. *Proc. Natl. Acad. Sci. U. S. A.* 109, 19900–19909.
- Dahl, G.E., Sainath, T.N., Hinton, G.E., 2013. Improving deep neural networks for LVCSR using rectified linear units and dropout. 2013 IEEE International Conference on Acoustics. <https://doi.org/10.1109/icassp.2013.6639346>.
- DeLong, M.R., 1990. Primate models of movement disorders of basal ganglia origin. *Trends Neurosci.* 13, 281–285.
- DeLong, M.R., Strick, P.L., 1974. Relation of basal ganglia, cerebellum, and motor cortex units to ramp and ballistic limb movements. *Brain Res.* 71, 327–335.
- Diedrichsen, J., Kornysheva, K., 2015. Motor skill learning between selection and execution. *Trends Cogn. Sci.* 19, 227–233.
- Diedrichsen, J., Verstynen, T., Lehman, S.L., Ivry, R.B., 2005. Cerebellar involvement in anticipating the consequences of self-produced actions during bimanual movements. *J. Neurophysiol.* 93, 801–812.
- Dominey, P.F., Arbib, M.A., 1992. A cortico-subcortical model for generation of spatially accurate sequential saccades. *Cereb. Cortex* 2, 153–175.
- Doya, K., 1999. What are the computations of the cerebellum, the basal ganglia and the cerebral cortex? *Neural Netw.* 12, 961–974.
- Doya, K., 2000. Complementary roles of basal ganglia and cerebellum in learning and motor control. *Curr. Opin. Neurobiol.* 10, 732–739.
- Doya, K., 2002. Metalearning and neuromodulation. *Neural Netw.* 15, 495–506.
- Doyon, J., Song, A.W., Karni, A., Lalonde, F., Adams, M.M., Ungerleider, L.G., 2002. Experience-dependent changes in cerebellar contributions to motor sequence learning. *Proc. Natl. Acad. Sci. U. S. A.* 99, 1017–1022.
- Doyon, J., Penhune, V., Ungerleider, L.G., 2003a. Distinct contribution of the cortico-striatal and cortico-cerebellar systems to motor skill learning. *Neuropsychologia* 41, 252–262.
- Doyon, J., Penhune, V., Ungerleider, L.G., 2003b. Distinct contribution of the cortico-striatal and cortico-cerebellar systems to motor skill learning. *Neuropsychologia* 41, 252–262.
- Doyon, J., Bellec, P., Amsel, R., Penhune, V., Monchi, O., Carrier, J., Lehericy, S., Benali, H., 2009. Contributions of the basal ganglia and functionally related brain structures to motor learning. *Behav. Brain Res.* 199, 61–75.
- Dudman, J.T., Krakauer, J.W., 2016. The basal ganglia: from motor commands to the control of vigor. *Curr. Opin. Neurobiol.* 37, 158–166.
- Edelman, G., 2001. Consciousness: the remembered present. *Ann. N. Y. Acad. Sci.* 929, 111–122.
- Eliasmith, C., Stewart, T.C., Choo, X., Bekolay, T., DeWolf, T., Tang, Y., Tang, C., Rasmussen, D., 2012. A large-scale model of the functioning brain. *Science* 338, 1202–1205.
- Fagg, A.H., Arbib, M.A., 1998. Modeling parietal-premotor interactions in control of grasping. *Neural Netw.* 11, 1277–1303.
- Faisal, A.A., Aldo Faisal, A., Selen, L.P.J., Wolpert, D.M., 2008. Noise in the nervous system. *Nat. Rev. Neurosci.* 9, 292–303.
- Feingold, A., Nini, A., Raz, A., Zelenskaya, V., Bergman, H., 1996. Functional connectivity and information processing in the basal ganglia of normal and parkinsonian monkeys. *Adv. Behav. Biol.* 217–223.
- Felleman, D.J., Van Essen, D.C., 1991. Distributed hierarchical processing in the primate cerebral cortex. *Cereb. Cortex* 1, 1–47.
- Fischer, A.G., Ullsperger, M., 2017. An update on the role of serotonin and its interplay with dopamine for reward. *Front. Hum. Neurosci.* 11, 484.
- Fogassi, L., 2005. Parietal lobe: from action organization to intention understanding. *Science* 308, 662–667.
- Fonollosa, J., Neftci, E., Rabinovich, M., 2015. Learning of chunking sequences in cognition and behavior. *PLoS Comput. Biol.* 11 e1004592.
- Frank, M.J., 2005. Dynamic dopamine modulation in the basal ganglia: a neurocomputational account of cognitive deficits in medicated and nonmedicated parkinsonism. *J. Cogn. Neurosci.* 17, 51–72.
- Franklin, D.J., Grossberg, S., 2017. A neural model of normal and abnormal learning and memory consolidation: adaptively timed conditioning, hippocampus, amnesia, neurotrophins, and consciousness. *Cogn. Affect. Behav. Neurosci.* 17, 24–76.
- Frey, U., Morris, R.G., 1998. Synaptic tagging: implications for late maintenance of hippocampal long-term potentiation. *Trends Neurosci.* 21, 181–188.
- Friston, K., 2010. The free-energy principle: a unified brain theory? *Nat. Rev. Neurosci.* 11, 127–138.
- Fuster, J., 2015. *The Prefrontal Cortex*. Academic Press.
- Galea, J.M., Mallia, E., Rothwell, J., Diedrichsen, J., 2015. The dissociable effects of punishment and reward on motor learning. *Nat. Neurosci.* 18, 597–602.
- George, D., Hawkins, J., 2009. Towards a mathematical theory of cortical micro-circuits. *PLoS Comput. Biol.* 5 e1000532.
- Giovannetti, T., Schwartz, M.F., Buxbaum, L.J., 2007. The coffee challenge: a new method for the study of everyday action errors. *J. Clin. Exp. Neuropsychol.* 29, 690–705.

- Goldenberg, G., Iriki, A., 2007. From sticks to coffee-maker: mastery of tools and technology by human and non-human primates. *Cortex* 43, 285–288.
- Goodale, M.A., Milner, A.D., 1992. Separate visual pathways for perception and action. *Trends Neurosci.* 15, 20–25.
- Goodfellow, I., Bengio, Y., Courville, A., 2016. *Deep Learning*. MIT Press.
- Graybiel, A.M., 1995. Building action repertoires: memory and learning functions of the basal ganglia. *Curr. Opin. Neurobiol.* 5, 733–741.
- Graybiel, A.M., 1998. The basal ganglia and chunking of action repertoires. *Neurobiol. Learn. Mem.* 70, 119–136.
- Graydon, F.X., Friston, K.J., Thomas, C.G., Brooks, V.B., Menon, R.S., 2005. Learning-related fMRI activation associated with a rotational visuo-motor transformation. *Brain Res. Cogn. Brain Res.* 22, 373–383.
- Grossberg, S., Kishnan, D., 2018. Neural dynamics of autistic repetitive behaviors and fragile X syndrome: basal ganglia movement gating and mGluR-Modulated adaptively timed learning. *Front. Psychol.* 9, 269.
- Gu, B.M., Cheng, R.K., Yin, B., Meck, W.H., 2011. Quinpirole-induced sensitization to noisy/sparse periodic input: temporal synchronization as a component of obsessive-compulsive disorder. *Neuroscience* 179, 143–150.
- Gurney, K., Prescott, T.J., Redgrave, P., 2001. A computational model of action selection in the basal ganglia. I. A new functional anatomy. *Biol. Cybern.* 84, 401–410.
- Haber, S.N., 2003. The primate basal ganglia: parallel and integrative networks. *J. Chem. Neuroanat.* 26, 317–330.
- Haber, S.N., Fudge, J.L., McFarland, N.R., 2000. Striatonigrostriatal pathways in primates form an ascending spiral from the shell to the dorsolateral striatum. *J. Neurosci.* 20, 2369–2382.
- Harrington, D.L., Zimbelman, J.L., Hinton, S.C., Rao, S.M., 2010. Neural modulation of temporal encoding, maintenance, and decision processes. *Cereb. Cortex* 20, 1274–1285.
- Hasselmo, M.E., 1995. Neuromodulation and cortical function: modeling the physiological basis of behavior. *Behav. Brain Res.* 67, 1–27.
- Hélie, S., Ell, S.W., Ashby, F.G., 2015. Learning robust cortico-cortical associations with the basal ganglia: an integrative review. *Cortex* 64, 123–135.
- Hikosaka, O., Sakamoto, M., Miyashita, N., 1993. Effects of caudate nucleus stimulation on substantia nigra cell activity in monkey. *Exp. Brain Res.* 95, 457–472.
- Hikosaka, O., Rand, M.K., Miyachi, S., Miyashita, K., 1995. Learning of sequential movements in the monkey: process of learning and retention of memory. *J. Neurophysiol.* 74, 1652–1661.
- Hikosaka, O., Nakamura, K., Sakai, K., Nakahara, H., 2002. Central mechanisms of motor skill learning. *Curr. Opin. Neurobiol.* 12, 217–222.
- Hinton, G.E., Sejnowski, T.J., 1999. *Unsupervised Learning: Foundations of Neural Computation*. MIT Press.
- Hoshi, E., Tremblay, L., Féger, J., Carras, P.L., Strick, P.L., 2005. The cerebellum communicates with the basal ganglia. *Nat. Neurosci.* 8, 1491–1493.
- Houk, J.C., Wise, S.P., 1995. Distributed modular architectures linking basal ganglia, cerebellum, and cerebral cortex: their role in planning and controlling action. *Cereb. Cortex* 5, 95–110.
- Houk, J.C., Bastianen, C., Fansler, D., Fishbach, A., Fraser, D., Reber, P.J., Roy, S.A., Simo, L.S., 2007. Action selection and refinement in subcortical loops through basal ganglia and cerebellum. *Philos. Trans. R. Soc. Lond. B Biol. Sci.* 362, 1573–1583.
- Ikai, Y., Takada, M., Shinonaga, Y., Mizuno, N., 1992. Dopaminergic and non-dopaminergic neurons in the ventral tegmental area of the rat project, respectively, to the cerebellar cortex and deep cerebellar nuclei. *Neuroscience* 51, 719–728.
- Inoue, K., Kawashima, R., Satoh, K., Kinomura, S., Goto, R., Sugiura, M., Ito, M., Fukuda, H., 1997. Activity in the parietal area during visuomotor learning with optical rotation. *Neuroreport* 8, 3979–3983.
- Iriki, A., Tanaka, M., Iwamura, Y., 1996. Coding of modified body schema during tool use by macaque postcentral neurones. *Neuroreport* 7, 2325–2330.
- Ito, M., 1984. The Cerebellum and Neural Control. Raven Pr.
- Ito, M., 1997. Cerebellar microcomplexes. *Int. Rev. Neurobiol.* 41, 475–487.
- Ito, M., 2008. Control of mental activities by internal models in the cerebellum. *Nat. Rev. Neurosci.* 9, 304–313.
- Ito, M., 2013. Error detection and representation in the olivo-cerebellar system. *Front. Neural Circ.* 7, 1.
- Ivry, R.B., Keele, S.W., Diener, H.C., 1988a. Dissociation of the lateral and medial cerebellum in movement timing and movement execution. *Exp. Brain Res.* 73, 167–180.
- Ivry, R.B., Keele, S.W., Diener, H.C., 1988b. Dissociation of the lateral and medial cerebellum in movement timing and movement execution. *Exp. Brain Res.* 73, 167–180.
- Izawa, J., Criscimagna-Hemminger, S.E., Shadmehr, R., 2012. Cerebellar contributions to reach adaptation and learning sensory consequences of action. *J. Neurosci.* 32, 4230–4239.
- Jiang, X., Pang, Y., Li, X., Pan, J., Xie, Y., 2018. Deep neural networks with elastic rectified linear units for object recognition. *Neurocomputing* 275, 1132–1139.
- Jin, X., Tecuapetla, F., Costa, R.M., 2014. Basal ganglia subcircuits distinctively encode the parsing and concatenation of action sequences. *Nat. Neurosci.* 17, 423–430.
- Jones, C.R.G., Jahanshahi, M., 2014. Contributions of the basal ganglia to temporal processing: evidence from parkinson's disease. *Timing Time Percept.* 2, 87–127.
- Kami, A., Meyer, G., Jezzard, P., Adams, M.M., Turner, R., Ungerleider, L.G., 1995. Functional MRI evidence for adult motor cortex plasticity during motor skill learning. *Nature* 377, 155–158.
- Kappel, D., Nessler, B., Maass, W., 2014. STDP installs in Winner-Take-All circuits an online approximation to hidden Markov model learning. *PLoS Comput. Biol.* 10, e1003511.
- Kiebel, S.J., Daunizeau, J., Friston, K.J., 2008. A hierarchy of time-scales and the brain. *PLoS Comput. Biol.* 4, e1000209.
- Kim, T., Hamade, K.C., Todorov, D., Barnett, W.H., Capps, R.A., Latash, E.M., Markin, S.N., Rybak, I.A., Molkov, Y.I., 2017. Reward based motor adaptation mediated by basal ganglia. *Front. Comput. Neurosci.* 11, 19.
- Kishore, A., Meunier, S., Popa, T., 2014. Cerebellar influence on motor cortex plasticity: behavioral implications for Parkinson's disease. *Front. Neurol.* 5, 68.
- Kitazawa, S., Kimura, T., Yin, P.-B., 1998. Cerebellar complex spikes encode both destinations and errors in arm movements. *Nature* 392, 494–497.
- Knudsen, E.I., 1994. Supervised learning in the brain. *J. Neurosci.* 14, 3985–3997.
- Koch, G., Oliveri, M., Caltagirone, C., 2009. Neural networks engaged in milliseconds and seconds time processing: evidence from transcranial magnetic stimulation and patients with cortical or subcortical dysfunction. *Philos. Trans. R. Soc. Lond. B Biol. Sci.* 364, 1907–1918.
- Kotz, S.A., Schwartz, M., Schmidt-Kassow, M., 2009. Non-motor basal ganglia functions: a review and proposal for a model of sensory predictability in auditory language perception. *Cortex* 45, 982–990.
- Koziol, L.F., Budding, D.E., 2009. *Subcortical Structures and Cognition: Implications for Neuropsychological Assessment*. Springer Science & Business Media.
- Krebs, H.I., Brashers-Krug, T., Rauch, S.L., Savage, C.R., Hogan, N., Rubin, R.H., Fischman, A.J., Alpert, N.M., 1998. Robot-aided functional imaging: application to a motor learning study. *Hum. Brain Mapp.* 6, 59–72.
- Lesage, E., Morgan, B.E., Olson, A.C., Meyer, A.S., Miall, R.C., 2012. Cerebellar rTMS disrupts predictive language processing. *Curr. Biol.* 22, R794–R795.
- Lesort, T., Díaz-Rodríguez, N., Goudou, J.-F.L., Filliat, D., 2018. State representation learning for control: an overview. *Neural Netw.* 108, 379–392.
- Lisman, J.E., Grace, A.A., 2005. The hippocampal-VTA loop: controlling the entry of information into long-term memory. *Neuron* 46, 703–713.
- Liu, P., Basso, M.A., 2008. Substantia nigra stimulation influences monkey superior colliculus neuronal activity bilaterally. *J. Neurophysiol.* 100, 1098–1112.
- Lu, X., Hikosaka, O., Miyachi, S., 1998. Role of monkey cerebellar nuclei in skill for sequential movement. *J. Neurophysiol.* 79, 2245–2254.
- Lusk, N.A., Petter, E.A., MacDonald, C.J., Meck, W.H., 2016a. Cerebellar, hippocampal, and striatal time cells. *Curr. Opin. Behav. Sci.* 8, 186–192.
- Lusk, N.A., Petter, E.A., MacDonald, C.J., Meck, W.H., 2016b. Cerebellar, hippocampal, and striatal time cells. *Curr. Opin. Behav. Sci.* 8, 186–192.
- Lusk, N.A., Petter, E.A., MacDonald, C.J., Meck, W.H., 2016c. Cerebellar, hippocampal, and striatal time cells. *Curr. Opin. Behav. Sci.* 8, 186–192.
- Mannella, F., Baldassarre, G., 2015. Selection of cortical dynamics for motor behaviour by the basal ganglia. *Biol. Cybern.* 109, 575–595.
- Mannella, F., Gurney, K., Baldassarre, G., 2013. The nucleus accumbens as a nexus between values and goals in goal-directed behavior: a review and a new hypothesis. *Front. Behav. Neurosci.* 7. <https://doi.org/10.3389/fnbeh.2013.00135>.
- Mannella, F., Mirolli, M., Baldassarre, G., 2016. Goal-directed behavior and instrumental devaluation: a neural system-level computational model. *Front. Behav. Neurosci.* 10. <https://doi.org/10.3389/fnbeh.2016.00181>.
- Markram, H., 1997. Regulation of synaptic efficacy by coincidence of postsynaptic APs and EPSPs. *Science* 275, 213–215.
- Marr, D., 1969. A theory of cerebellar cortex. *J. Physiol.* 202, 437–470.
- Mathis, M.W., Mathis, A., Uchida, N., 2017. Somatosensory cortex plays an essential role in forelimb motor adaptation in mice. *Neuron* 93, 1493–1503.e6.
- Meck, W.H., Malapani, C., 2004. Neuroimaging of interval timing. *Cogn. Brain Res.* 21, 133–137.
- Melchitzky, D.S., Lewis, D.A., 2000. Tyrosine hydroxylase- and dopamine transporter-immunoreactive axons in the primate cerebellum. Evidence for a lobular- and laminar-specific dopamine innervation. *Neuropsychopharmacology* 22, 466–472.
- Merchant, H., Harrington, D.L., Meck, W.H., 2013. Neural basis of the perception and estimation of time. *Annu. Rev. Neurosci.* 36, 313–336.
- Miall, C., 1989. The storage of time intervals using oscillating neurons. *Neural Comput.* 1, 359–371.
- Miall, R.C., Galea, J., 2016. Cerebellar damage limits reinforcement learning. *Brain* 139, 4–7.
- Miall, R.C., Reckess, G.Z., Imamizu, H., 2001. The cerebellum coordinates eye and hand tracking movements. *Nat. Neurosci.* 4, 638–644.
- Middleton, F.A., Strick, P.L., 1998. The cerebellum: an overview. *Trends Cogn. Sci.* 2, 305–306.
- Middleton, F.A., Strick, P.L., 2000. Basal ganglia output and cognition: evidence from anatomical, behavioral, and clinical studies. *Brain Cogn.* 42, 183–200.
- Miller, E.K., Cohen, J.D., 2001. An integrative theory of prefrontal cortex function. *Annu. Rev. Neurosci.* 24, 167–202.
- Mirolli, M., Mannella, F., Baldassarre, G., 2010. The roles of the amygdala in the affective regulation of body, brain, and behaviour. *Conn. Sci.* 22, 215–245.
- Miyachi, S., Hikosaka, O., Lu, X., 2002. Differential activation of monkey striatal neurons in the early and late stages of procedural learning. *Exp. Brain Res.* 146, 122–126.
- Mogenson, G.J., Jones, D.L., Yim, C.Y., 1980. From motivation to action: functional interface between the limbic system and the motor system. *Prog. Neurobiol.* 14, 69–97.
- Molinari, M., Filippini, V., Leggio, M.G., 2002. Neuronal plasticity of interrelated cerebellar and cortical networks. *Neuroscience* 111, 863–870.
- Muller, T., Nobre, A.C., 2014. Perceiving the passage of time: neural possibilities. *Ann. N. Y. Acad. Sci.* 1326, 60–71.
- Nachev, P., Kennard, C., Husain, M., 2008. Functional role of the supplementary and pre-supplementary motor areas. *Nat. Rev. Neurosci.* 9, 856–869.
- Nambu, A., Tokuno, H., Takada, M., 2002. Functional significance of the cortico-subthalamic-pallidum “hyperdirect” pathway. *Neurosci. Res.* 43, 111–117.
- Ngezhayah, A., Schachner, M., Artola, A., 2000. Synaptic activity modulates the induction of bidirectional synaptic changes in adult mouse Hippocampus. *J. Neurosci.* 20, 2451–2458.
- Niv, Y., 2009. Reinforcement learning in the brain. *J. Math. Psychol.* 53, 139–154.
- O'Reilly, R.C., Frank, M.J., 2006. Making working memory work: a computational model of learning in the prefrontal cortex and basal ganglia. *Neural Comput.* 18, 283–328.
- O'Reilly, R.C., Munakata, Y., 2000. *Computational Explorations in Cognitive Neuroscience: Understanding the Mind by Simulating the Brain*. MIT Press.
- Oztop, E., Bradley, N.S., Arbib, M.A., 2004. Infant grasp learning: a computational model. *Exp. Brain Res.* 158, 480–503.
- Panagopoulos, N.T., Papadopoulos, G.C., Matsakis, N.A., 1991. Dopaminergic innervation and binding in the rat cerebellum. *Neurosci. Lett.* 130, 208–212.
- Passingham, R.E., Wise, S.P., 2012. Human prefrontal cortex. *Neurol. Prefrontal Cortex* 265–308.

- Pastor, M.A., Macaluso, E., Day, B.L., Frackowiak, R.S.J., 2006. The neural basis of temporal auditory discrimination. *Neuroimage* 30, 512–520.
- Penhune, V.B., Steele, C.J., 2012. Parallel contributions of cerebellar, striatal and M1 mechanisms to motor sequence learning. *Behav. Brain Res.* 226, 579–591.
- Petter, E.A., Lusk, N.A., Hesslow, G., Meck, W.H., 2016a. Interactive roles of the cerebellum and striatum in sub-second and supra-second timing: support for an initiation, continuation, adjustment, and termination (ICAT) model of temporal processing. *Neurosci. Biobehav. Rev.* 71, 739–755.
- Petter, E.A., Lusk, N.A., Hesslow, G., Meck, W.H., 2016b. Interactive roles of the cerebellum and striatum in sub-second and supra-second timing: support for an initiation, continuation, adjustment, and termination (ICAT) model of temporal processing. *Neurosci. Biobehav. Rev.* 71, 739–755.
- Petter, E.A., Lusk, N.A., Hesslow, G., Meck, W.H., 2016c. Interactive roles of the cerebellum and striatum in sub-second and supra-second timing: support for an initiation, continuation, adjustment, and termination (ICAT) model of temporal processing. *Neurosci. Biobehav. Rev.* 71, 739–755.
- Petter, E.A., Lusk, N.A., Hesslow, G., Meck, W.H., 2016d. Interactive roles of the cerebellum and striatum in sub-second and supra-second timing: support for an initiation, continuation, adjustment, and termination (ICAT) model of temporal processing. *Neurosci. Biobehav. Rev.* 71, 739–755.
- Prescott, T.J., Montes González, F.M., Gurney, K., Humphries, M.D., Redgrave, P., 2006. A robot model of the basal ganglia: behavior and intrinsic processing. *Neural Netw.* 19, 31–61.
- Puig, M.V., Rose, J., Schmidt, R., Freund, N., 2014. Dopamine modulation of learning and memory in the prefrontal cortex: insights from studies in primates, rodents, and birds. *Front. Neural Circ.* 8, 93.
- Ramnani, N., Toni, I., Passingham, R.E., Haggard, P., 2001. The cerebellum and parietal cortex play a specific role in coordination: a PET study. *Neuroimage* 14, 899–911.
- Redgrave, P., Prescott, T.J., Gurney, K., 1999. The basal ganglia: a vertebrate solution to the selection problem? *Neuroscience* 89, 1009–1023.
- Reis, J., Schambra, H.M., Cohen, L.G., Buch, E.R., Fritsch, B., Zarahn, E., Celnik, P.A., Krakauer, J.W., 2009. Noninvasive cortical stimulation enhances motor skill acquisition over multiple days through an effect on consolidation. *Proc. Natl. Acad. Sci. U. S. A.* 106, 1590–1595.
- Riesenhuber, M., Poggio, T., 1999. Hierarchical models of object recognition in cortex. *Nat. Neurosci.* 2, 1019–1025.
- Rodríguez, A., Whitson, J., Granger, R., 2004. Derivation and analysis of basic computational operations of thalamocortical circuits. *J. Cogn. Neurosci.* 16, 856–877.
- Rogers, T.D., Dickson, P.E., McKimm, E., Heck, D.H., Goldowitz, D., Blaha, C.D., Mittleman, G., 2013. Reorganization of circuits underlying cerebellar modulation of prefrontal cortical dopamine in mouse models of autism spectrum disorder. *Cerebellum* 12, 547–556.
- Sakai, S.T., 2013. Cerebellar thalamic and thalamocortical projections. *Handbook of the Cerebellum and Cerebellar Disorders*. pp. 529–547.
- Sakai, S.T., Grofovà, I., 2002. Distribution of the basal ganglia and cerebellar projections to the rodent motor thalamus. *Adv. Behav. Biol.* 455–462.
- Schirmer, A., Meck, W.H., Penney, T.B., 2016. The socio-temporal brain: connecting people in time. *Trends Cogn. Sci.* 20, 760–772.
- Schmahmann, J.D., Pandya, D.N., 1997. The cerebrotocerebellar system. *Int. Rev. Neurobiol.* 41, 31–60.
- Schultz, W., 1997. Dopamine neurons and their role in reward mechanisms. *Curr. Opin. Neurobiol.* 7, 191–197.
- Schwartz, M., Keller, P.E., Kotz, S.A., 2016. Spontaneous, synchronized, and corrective timing behavior in cerebellar lesion patients. *Behav. Brain Res.* 312, 285–293.
- Schweighofer, N., Arbib, M.A., Dominey, P.F., 1996a. A model of the cerebellum in adaptive control of saccadic gain. *Biol. Cybern.* 75, 29–36.
- Schweighofer, N., Arbib, M.A., Dominey, P.F., 1996b. A model of the cerebellum in adaptive control of saccadic gain. I. The model and its biological substrate. *Biol. Cybern.* 75, 19–28.
- Schweighofer, N., Spoelstra, J., Arbib, M.A., Kawato, M., 1998. Role of the cerebellum in reaching movements in humans. II. A neural model of the intermediate cerebellum. *Eur. J. Neurosci.* 10, 95–105.
- Schweighofer, N., Doya, K., Lay, F., 2001. Unsupervised learning of granule cell sparse codes enhances cerebellar adaptive control. *Neuroscience* 103, 35–50.
- Schweighofer, N., Doya, K., Kuroda, S., 2004. Cerebellar aminergic neuromodulation: towards a functional understanding. *Brain Res. Brain Res. Rev.* 44, 103–116.
- Seidler, R.D., Noll, D.C., Chintalapati, P., 2006. Bilateral basal ganglia activation associated with sensorimotor adaptation. *Exp. Brain Res.* 175, 544–555.
- Seidler, R.D., Bo, J., Anguera, J.A., 2012. Neurocognitive contributions to motor skill learning: the role of working memory. *J. Mot. Behav.* 44, 445–453.
- Shadmehr, R., Holcomb, H.H., 1997. Neural correlates of motor memory consolidation. *Science* 277, 821–825.
- Shadmehr, R., Holcomb, H.H., 1999. Inhibitory control of competing motor memories. *Exp. Brain Res.* 126, 235–251.
- Shadmehr, R., Krakauer, J.W., 2008. A computational neuroanatomy for motor control. *Exp. Brain Res.* 185, 359–381.
- Sherman, S.M., 2007. The thalamus is more than just a relay. *Curr. Opin. Neurobiol.* 17, 417–422.
- Sherman, S.M., Guillery, R.W., 1998. On the actions that one nerve cell can have on another: distinguishing “drivers” from “modulators.”. *Proc. Natl. Acad. Sci. U. S. A.* 95, 7121–7126.
- Shmuelof, L., Krakauer, J.W., Mazzoni, P., 2012. How is a motor skill learned? Change and invariance at the levels of task success and trajectory control. *J. Neurophysiol.* 108, 578–594.
- Sil'kis, I.G., 2003. The involvement of dopamine in strengthening cortical signals activating NMDA receptors in the striatum (a hypothetical mechanism). *Neurosci. Behav. Physiol.* 33, 379–386.
- Smeal, R.M., Keefe, K.A., Wilcox, K.S., 2008. Differences in excitatory transmission between thalamic and cortical afferents to single spiny efferent neurons of rat dorsal striatum. *Eur. J. Neurosci.* 28, 2041–2052.
- Smith, M.A., Shadmehr, R., 2005. Intact ability to learn internal models of arm dynamics in Huntington's disease but not cerebellar degeneration. *J. Neurophysiol.* 93, 2809–2821.
- Spampinato, D., Celnik, P., 2017. Temporal dynamics of cerebellar and motor cortex physiological processes during motor skill learning. *Sci. Rep.* 7, 40715.
- Spoelstra, J., Arbib, M.A., 2001. Cerebellar microcomplexes and the modulation of motor pattern generators. *Auton. Robots* 11, 273–278.
- Strick, P.L., Dum, R.P., Fiez, J.A., 2009. Cerebellum and nonmotor function. *Annu. Rev. Neurosci.* 32, 413–434.
- Sutton, R.S., 1988. Learning to predict by the methods of temporal differences. *Mach. Learn.* 3, 9–44.
- Sutton, R.S., Barto, A.G., 2018. *Reinforcement Learning: An Introduction*. A Bradford Book.
- Synofzik, M., Lindner, A., Thier, P., 2008. The cerebellum updates predictions about the visual consequences of one's behavior. *Curr. Biol.* 18, 814–818.
- Tan, H., Wade, C., Brown, P., 2016. Post-movement Beta activity in sensorimotor cortex indexes confidence in the estimations from internal models. *J. Neurosci.* 36, 1516–1528.
- Tanji, J., 2001. Sequential organization of multiple movements: involvement of cortical motor areas. *Annu. Rev. Neurosci.* 24, 631–651.
- Teke, S., Grube, M., Griffiths, T.D., 2011. A unified model of time perception accounts for duration-based and beat-based timing mechanisms. *Front. Integr. Neurosci.* 5, 90.
- Therrien, A.S., Wolpert, D.M., Bastian, A.J., 2016. Effective reinforcement learning following cerebellar damage requires a balance between exploration and motor noise. *Brain* 139, 101–114.
- Thill, S., Caligiore, D., Borghi, A.M., Ziemke, T., Baldassarre, G., 2013. Theories and computational models of affordance and mirror systems: an integrative review. *Neurosci. Biobehav. Rev.* 37, 491–521.
- Thoma, P., Bellebaum, C., Koch, B., Schwarz, M., Daum, I., 2008. The cerebellum is involved in reward-based reversal learning. *Cerebellum* 7, 433–443.
- Thompson, R.F., Steinmetz, J.E., 2009. The role of the cerebellum in classical conditioning of discrete behavioral responses. *Neuroscience* 162, 732–755.
- Thorp, E.B., Kording, K.P., Mussa-Ivaldi, F.A., 2017. Using noise to shape motor learning. *J. Neurophysiol.* 117, 728–737.
- Turner, R.S., Desmurget, M., 2010. Basal ganglia contributions to motor control: a vigorous tutor. *Curr. Opin. Neurobiol.* 20, 704–716.
- Vias, C., Dick, A.S., 2017. Cerebellar contributions to language in typical and atypical development: a review. *Dev. Neuropsychol.* 42, 404–421.
- Wagner, M.J., Kim, T.H., Savall, J., Schnitzer, M.J., Luo, L., 2017. Cerebellar granule cells encode the expectation of reward. *Nature* 544, 96–100.
- Wang, J.X., Kurth-Nelson, Z., Kumaran, D., Tirumala, D., Soyer, H., Leibo, J.Z., Hassabis, D., Botvinick, M., 2018. Prefrontal cortex as a meta-reinforcement learning system. *Nat. Neurosci.* 21, 860–868.
- Waters-Metenier, S., Husain, M., Wiestler, T., Diedrichsen, J., 2014. Bihemispheric transcranial direct current stimulation enhances effector-independent representations of motor synergy and sequence learning. *J. Neurosci.* 34, 1037–1050.
- Whittington, J.C.R., Bogacz, R., 2019. Theories of error back-propagation in the brain. *Trends Cogn. Sci.* <https://doi.org/10.1016/j.tics.2018.12.005>.
- Willingham, D.B., 1998. A neuropsychological theory of motor skill learning. *Psychol. Rev.* 105, 558–584.
- Wolpert, D.M., Miall, R.C., Kawato, M., 1998. Internal models in the cerebellum. *Trends Cogn. Sci.* 2, 338–347.
- Wolpert, D.M., Doya, K., Kawato, M., 2003. A unifying computational framework for motor control and social interaction. *Philos. Trans. R. Soc. Lond. B Biol. Sci.* 358, 593–602.
- Wolpert, D.M., Diedrichsen, J., Randall Flanagan, J., 2011. Principles of sensorimotor learning. *Nat. Rev. Neurosci.* 12, 739–751.
- Wong, C.W., Olafsson, V., Plank, M., Snider, J., Halgren, E., Poizner, H., Liu, T., 2013. Resting-state fMRI activity in the basal ganglia predicts unsupervised learning performance in a virtual reality environment. 2013 6th International IEEE/EMBS Conference on Neural Engineering (NER). <https://doi.org/10.1109/ner.2013.6696238>.
- Yin, H.H., Knowlton, B.J., 2006. The role of the basal ganglia in habit formation. *Nat. Rev. Neurosci.* 7, 464–476.
- Yin, B., Terhune, D.B., Smythies, J., Meck, W.H., 2016. Claustrum, consciousness, and time perception. *Curr. Opin. Behav. Sci.* 8, 258–267.
- Yttri, E.A., Dudman, J.T., 2016. Opponent and bidirectional control of movement velocity in the basal ganglia. *Nature* 533, 402–406.