



Strathprints Institutional Repository

Borg, S.P. and Kelly, N.J. (2013) *High resolution performance analysis of micro-trigeneration in an energy-efficient residential building*. Energy and Buildings, 67. pp. 153-165. ISSN 0378-7788

Strathprints is designed to allow users to access the research output of the University of Strathclyde. Copyright © and Moral Rights for the papers on this site are retained by the individual authors and/or other copyright owners. You may not engage in further distribution of the material for any profitmaking activities or any commercial gain. You may freely distribute both the url (<http://strathprints.strath.ac.uk/>) and the content of this paper for research or study, educational, or not-for-profit purposes without prior permission or charge.

Any correspondence concerning this service should be sent to Strathprints administrator: <mailto:strathprints@strath.ac.uk>

HIGH RESOLUTION PERFORMANCE ANALYSIS OF MICRO-TRIGENERATION IN AN ENERGY-EFFICIENT RESIDENTIAL BUILDING

*Simon Paul Borg*¹, *Nicolas James Kelly*²

***Corresponding Author:** e-mail: (*simon.p.borg@um.edu.mt*); Telephone (+356 23402870)

ABSTRACT

Trigeneration has long been proposed as a means to improve energy-efficiency for large and medium sized buildings. To curb increasing energy demand in the residential sector, researchers are now focusing their attention on adapting trigeneration to residential buildings. The literature is full of examples pertaining to the performance of trigeneration in large and medium sized commercial buildings, however little is known on the performance of micro-trigeneration inside residential buildings, particularly under a range of operating conditions. To understand the influence that parameters such as changes in thermal and electrical loading or different plant configurations have on the performance of micro-trigeneration, this research makes use of a detailed model of a Maltese apartment building, and associated micro-trigeneration system. The performance of the model is simulated using a whole building simulation tool run at high-resolution minute time frequency over a number of different operating conditions and scenarios. Each scenario was then assessed on the basis of the system's energetic, environmental and economic performance. The results show that, compared to separate generation the use of a residential micro-trigeneration system reduces primary energy consumption by about 40%, but also that the system's financial performance is highly susceptible to the operating conditions.

1. INTRODUCTION

Trigeneration is viewed as the natural extension to Combined Heat and Power (CHP) in countries where significant cooling of buildings is required ([1, 2]). Unlike separate generation in which energy requirements are satisfied independently through different energy flows, trigeneration makes use of an energy cascading process where the waste heat from electrical power production is utilised to satisfy either a heating or cooling demand in a single energy flow process [3]. In the latter case use is made of a thermally activated chiller (TAC). This re-utilisation of the waste heat to supply a cooling load could be useful in reducing the increased energy demand arising from the increased use of vapour compression-based air conditioning [4].

¹ *Department of Environmental Design, Faculty for the Built Environment, University of Malta, Malta*

² *Energy Systems Research Unit, Department of Mechanical and Aerospace Engineering, University of Strathclyde, Glasgow, UK*

Various studies have shown the feasibility of trigeneration particularly when used with large and medium scale loads such as industry [5], hotels [6], schools [7] and supermarkets [8]. The stable demand for energy in these sectors ensures that trigeneration systems offer attractive rates of return on investment. Research interest (*e.g.* IEA's Annex 42 [9] and Annex 54 [10]), has now shifted towards using micro-scale trigeneration in residential buildings. Micro-scale generation is defined as a system with an electrical capacity typically of not more than 15 kW_{el} [11]).

1.1 Assessing the performance of micro-trigeneration in residential buildings

An important aspect in determining the feasibility of micro-trigeneration in residential buildings is the assessment of its energetic, environmental and economic performance. Research has so far mostly focused on the documentation of results obtained from experimental test rigs [12-16] or demonstration projects such as that by Henning *et al.* [17]. The results from these experimental systems give an indication of what micro-trigeneration system performance should be for specific conditions. These studies however, stop short of indicating how a micro-trigeneration system would perform under more realistic operating conditions. Moreover, other operating factors such as building load, occupancy patterns and plant configuration will also dictate the micro-trigeneration system's ultimate performance. A final factor, which to-date has been under-explored, is the performance and feasibility of micro-trigeneration systems in future, energy efficient residential buildings.

To assess the influence of different operating conditions for large, medium and small scale trigeneration researchers have used optimization modelling techniques [18] whereby a 'cost function' (*e.g.* capacity, storage size, *etc.*) is optimised for various boundary conditions. For example, Wang *et al.* [18] and Carvalho *et al.* [19] use optimisation to assess the performance of small scale trigeneration under different climatic conditions and in different buildings (*e.g.* hotels, hospitals, *etc.*). Kavvadias *et al.* [20], use an optimization process to understand the influence of system sizing and other parameters on the project investment. A common aspect of all these studies is that the number of variables investigated was limited to a selected few (*e.g.* the CHP electrical power rating) and could perhaps best be described as constrained optimisations. To optimise a complete micro-trigeneration system model (including the building it serves) against a large number of different operating conditions would be a substantial undertaking, as the number of variables involved is huge.

A more pragmatic approach adopted in this paper makes use of a combined deterministic and sensitivity analysis methodology suggested by Dorer and Weber in [21]. The whole building simulation tool ESP-r [22] is used to

assess the performance of a grid-connected micro-trigeneration system under a number of realistic operational scenarios. The micro-trigeneration performance can be compared for the different scenarios, whilst the effect that key parameters will have on a specific scenario can be assessed using a sensitivity analysis. According to Dorer and Weber [21], this approach permits a high degree of flexibility vis-à-vis the type and number of operating conditions studied, and provides a comprehensive picture of performance. Further, the use of a whole building simulation tool such as ESP-r ensures that the complexities arising from the coupling between the trigeneration plant and the building are taken into account. As discussed by Stokes in [23] the use of a time resolution of 1-minute ensures that the simulations are modelled with enough temporal precision to characterise the highly varying nature of residential energy demands, particularly electricity. Also, high resolution modelling is required to obtain an accurate picture of electrical import and export [24].

The model used in these simulations represents a micro-trigeneration system supplying both the electrical and the thermal demands of a multi-family residential building in the island of Malta. Given its location in the middle of the Mediterranean sea, Malta is a good example of the sub-tropical *Csa* Köppen Climate Classification (moderate rainy winters and hot dry summers) [25], prevailing in substantial parts of southern Europe.

1.2 FACTORS INVESTIGATED

The number of variables which can influence the performance of a residential micro-trigeneration system is vast. So, for this study to be tractable, a select range of factors most likely to affect the viability of micro-trigeneration in housing were investigated, particularly factors relating to improved energy performance in housing and the wider energy network; these are summarised in Table 1.

Table 1 – Factors influencing performance investigated in this study

Factors	Possible effect on micro-trigeneration system
Improvement in building fabric	Changes the thermal demand - Heat load and operating time
Building size and number of occupants	Changes the thermal demand - Heat load and operating time
Improvement in household appliances' electrical efficiency	Changes the electrical demand - Reduced electrical demand
Addition of a chilled water storage tank	Changes operating mode
Sensitivity to grid network improvements	Changes the comparison with separate generation
Sensitivity to fuel prices	Changes the system's running costs
Sensitivity to electricity tariffs	Changes the comparison with separate generation

2. MODELLING

The following sections describe the modelling approach employed in this paper.

2.1 *Modelling the building*

2.1.1 *Geometrical features*

Figure 1 shows the geometrical features of a typical Maltese building [26] modelled in ESP-r, Which is representative of new Maltese residential buildings; it reflects the shift from traditional single-family terraced housing to apartment blocks. The model represents a building block abutting an adjacent building on the east and north sides. Compared to traditional buildings in Malta (where de-centralised HVAC systems would be the preferred choice), these type of buildings are more suitable for a micro-trigeneration system, with a high occupancy density (large number of apartments) and the fact that many already have a centralised HVAC system. The building has a total floor space of about 360m², 120m² per floor, which is typical for Malta [27].

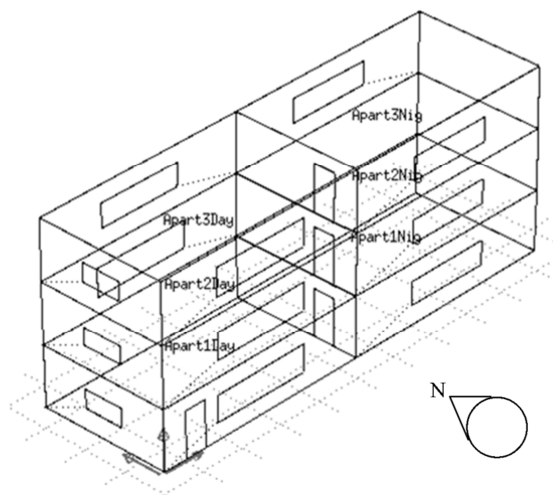

Fig. 1 - External view of the modelled building

Each floor was modelled explicitly and represents an individual apartment housing a single household. The ground floor apartment houses a 2 person household, the middle floor houses a 3 person household and the top floor houses a 4 person household; these three household sizes typify around 70% of the total number of households in Malta [28]. Further, each apartment was modelled using two thermal zones, with each zone representing an aggregated internal space: for all floors, the south/west facing zone represented the living area, grouping together the living room and kitchen for that particular apartment; the zone facing south/east was the bedroom area, grouping together the bedrooms of each apartment. This modelling approach is along the lines of that proposed by ASHRAE in [29] spaces with a similar use can be grouped as a single zone. Internal heat gains associated with the occupants and appliances present inside the building were modelled through the use of values present in the ASHRAE handbook [29].

2.1.2 Enlarged three storey building to represent 6 household building

One of the factors mentioned as having a potential impact on micro-trigeneration performance is building size and occupancy. An increased dwelling size and a larger number of occupants directly effects the operational time of a residential micro-trigeneration system and may have an important influence on its performance and feasibility. Consequently, a second larger model variant accommodating 6 households was developed in which, each floor of the building was enlarged along with additional thermal mass. In this second enlarged building, the number of occupants was doubled from 9 to 18, with the individual floors modelled to represent two households each, as outlined in Table 2.

Table 2 – Household type and occupancy for the enlarged 6 household building

Floor	Household Type	Number of Occupants
Ground Floor	2 and 3 Person Households	5
Middle Floor	3 and 4 Person Households	7
Top Floor	4 and 2 Person Households	6

2.1.3 Building fabric

As discussed in various studies including those by Tejedor *et al.* [30], Anastaselos *et al.* [31], D’Orazio *et al.* [32] and Nikolaidis *et al.* [33], an important variable which needs to be considered when assessing the performance of energy efficient residential buildings is the quality of the building fabric. Two sets of building fabrics were therefore used in the simulations (Table 3).

- A *poorly-insulated building fabric scenario*, typical of most buildings in Malta built before the implementation of the Energy Performance in Buildings Directive (EPBD) [34]. Buhagiar [35] and Tejedor *et al.* [30] give a reasonably detailed account of what were the typical building standards used in Malta; and
- A *highly-insulated building fabric scenario* satisfying the minimum local requirements set by the *Technical Guidance - Conservation of Fuel, Energy and Natural Resources* [36], as required by the Maltese transposition of the EPBD [34].

Table 3 – Poorly-insulated and highly-insulated building fabric scenarios

Item	Poorly-insulated building fabric scenario	Highly-insulated building fabric scenario
South façade exposed external	230mm soft limestone block/ 10 mm cavity/ 150mm concrete block / 12.5mm gypsum board. Total U-Value - 1.194 W/m²K	230mm soft limestone block/50mm expanded polystyrene /150mm concrete block /12.5mm gypsum board. Total U-Value - 0.428 W/m²K

walls		
Other exposed external walls	230mm concrete block/ 12.5mm gypsum board. Total U-Value - 1.889 W/m²K	230mm limestone block/50mm expanded polystyrene/ 150mm concrete block/ 12.5mm gypsum board. Total U-Value - 0.428 W/m²K
Non-exposed external walls	230mm concrete block/ 12.5mm gypsum board. Total U-Value - 1.889 W/m²K	230mm concrete block/ 10mm expanded polystyrene board/ 12.5mm gypsum board. Total U-Value - 1.159 W/m²K
Internal walls	150mm concrete block finished on both sides with 12.5mm gypsum board. Total U-Value - 1.907 W/m²K	
Roof	4mm dark coloured roof felt/ 75mm lean concrete mix/ 100mm layer of crushed limestone/ 150mm 2% steel reinforced concrete/12.5mm ceiling gypsum board. Total U-Value - 1.390 W/m²K	12mm white coloured roof felt/ 75mm lean concrete mix /100mm layer of crushed limestone/180mm roof insulation board/ 150mm 2% steel reinforced concrete/12.5mm ceiling gypsum board. Total U-Value - 0.588 W/m²K
Ceiling	6mm tile / 50mm lean concrete mix / 50mm layer of crushed limestone/ 150mm 2% steel reinforced concrete covered/ 12.5mm ceiling gypsum board. Total U-Value - 1.722 W/m²K	6mm tile / 50mm lean concrete mix/50mm roof insulation board / 50mm layer of crushed limestone, a 50mm / 150mm 2% steel reinforced concrete/12.5mm ceiling gypsum board. Total U-Value - 1.185 W/m²K
Glazing	6mm single glazing. Total U-Value - 3.733 W/m²K	Air filled 6mm double glazing with 12mm gap. Total U-Value - 2.265 W/m²K

Various combinations were developed, representative of different building scenarios (*e.g.* 3 household building with poorly-insulated building fabric, 6 household building with poorly-insulated building fabric, *etc.*). Each scenario represents a different thermal load, based on building size, number of occupants and building fabric. For summer simulations, shading was added in the form of external louvres, modelled to cover about 70% of the aperture, typical of shading devices used in Mediterranean climates [37].

2.2 *Plant networks*

2.2.1 *Base case plant configuration*

The base case plant configuration used in the simulations for the 3 household building is shown in Figure 2.

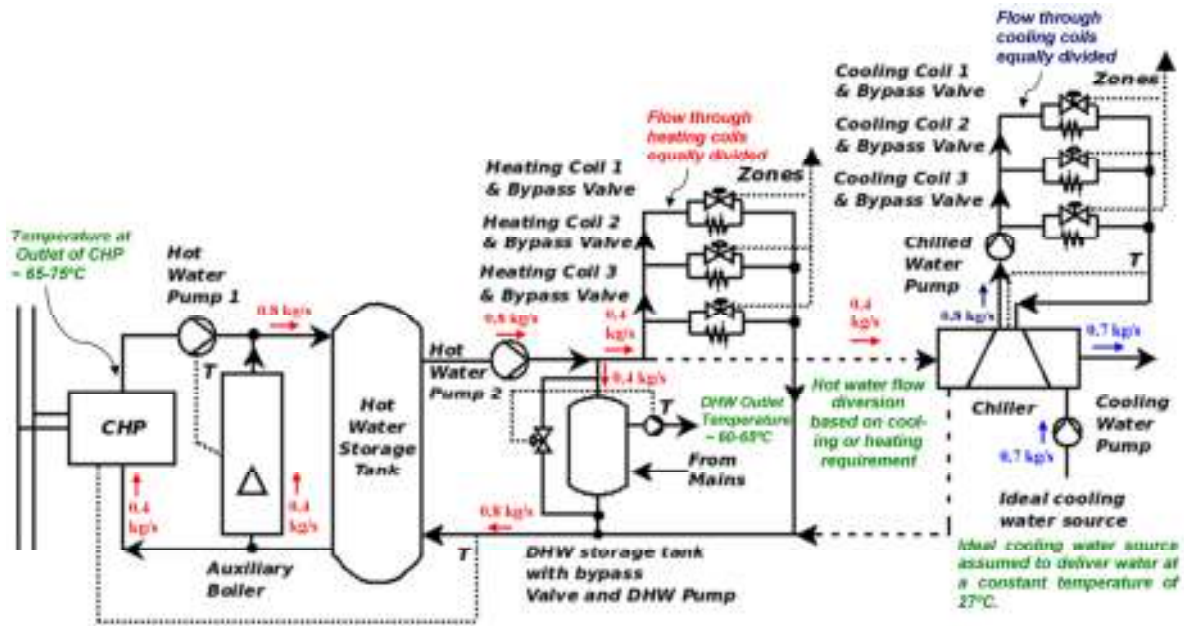

Fig. 2 - Base case micro-trigeneration plant configuration

The CHP component model used to provide heating and electrical power is the same as that developed and calibrated within IEA Annex 42 [38], and represents a $5.5 \text{ kW}_{el}/12.5 \text{ kW}_{th}$ internal combustion engine by Senertec Dachs [39, 40]. The model, originally calibrated for natural gas, has flexible fuel combustion capabilities, allowing different fuel types to be used. For this study the unit runs on Liquefied Petroleum Gas (LPG), as natural gas is unavailable in Malta. The CHP engine was thermally controlled using an ‘On’/‘Off’ control, sensing the return temperature to the hot water storage tank. The system was grid connected, enabling both export and import of electricity. The recycled ‘waste heat’ stored in the hot water storage tank, was recovered from the engine’s cooling system and the combustion exhaust gases. To cover any shortfalls in the heat supply, an auxiliary boiler was connected in parallel to the CHP unit. In the ventilation system, depending on the type of space conditioning required, hot water was fed either to the absorption chiller (the 10 kW_{th} absorption chiller by SK SonnenKlima GmbH [41]) described in detail by Borg and Kelly [42]) or directly to the heating coils. The absorption chiller supplied chilled water to cooling coils in the ventilation system. Separate ventilation supply ducts were used to supply each individual apartment, each containing its own cooling and heating coil. The air flow could be manipulated so as to permit control of the individual apartment temperatures. A similar plant network, adapted to cater for an increased thermal load (e.g. increased hot water storage), was used for the 6 household building.

2.2.2 Use of chilled water storage tank

A common variant of the base case plant configuration is the inclusion of a chilled water storage tank that acts as a

system buffer, balancing supply and demand and reducing sharp fluctuations in operation. To investigate its impact on performance the base case plant configuration was therefore modified to include a 0.3m³ chilled water buffer tank between the chiller and the cooling coils. The selected tank size is typical used for residential water storage [43].

2.3 *Modelling the electrical loads*

An important operating condition which effects micro-trigeneration system performance is the electrical demand of the building. To account for the effect of electrical efficiency improvements in Maltese buildings, two household appliance electrical efficiency scenarios were modelled:

- A *current electrical efficiency scenario*; and
- A *future high electrical efficiency scenario* reflecting future technology performance.

For each floor of the model stochastic, high resolution electrical demand profiles were developed using a validated process described by Borg and Kelly [44]. Low-resolution hourly data of different individual household appliances obtained from the Italian REMODECE database [45] were first processed to create seasonal variations of individual monthly data and then converted into high-resolution minutely data either reflecting current or improved appliance energy-efficiency levels. Aggregation of the individual household appliances load profiles results in the creation of aggregated household electrical demand profiles for both current and future electrical efficiency as illustrated in Figure 3.

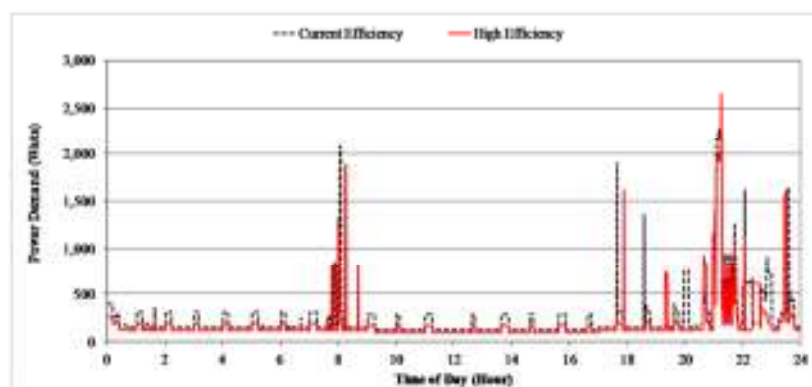

Fig. 3 - Current and high electrical efficiency demand profiles for the middle floor in the 3 household building

2.4 *Modelling domestic hot water consumption*

Profiles that represent the hot water consumption for the 3 and the 6 household buildings were developed based on

research conducted by the IEA's Annex 42 [46] and Annex 26 [47]. Specifically, the interactive tool *DHWcalc* created by Jordan and Vajen [48] was used to create realistic domestic hot water demand at a 1-minute time resolution. The annual average daily hot water usage for each individual occupant was taken as 30 litres/day, typical of hot water usage in Malta and Cyprus [49, 50]. Figure 4 shows the total water drawn for the 3 household building over a 1-week period.

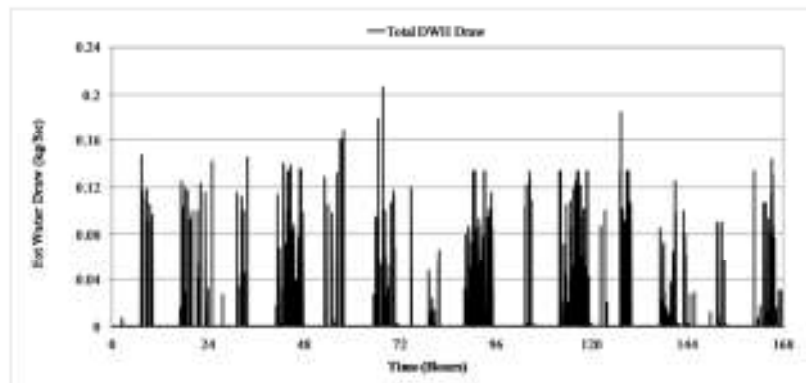

Fig. 4 - Hot water draw profile for a period of 1 week

3. SCENARIOS INVESTIGATED AND ANALYSIS METRICS

3.1 Scenarios investigated

Table 4 lists the specific scenarios modelled, which use the hot water and electrical demand profiles and plant/building configurations discussed in the previous sections. The results from these simulations enabled the effect of different operating conditions (such as building size, occupancy, fabric and appliance electrical efficiency) on micro-trigeneration system performance to be assessed. Each scenario is based primarily on:

- the type of building, *i.e.* 3 household building (9 persons) or 6 household building (18 persons); and
- the type of plant configuration adopted, *i.e.* base case plant configuration or base case plant configuration with additional chilled water storage tank.

For each scenario shown in Table 4 a subscript term then indicates:

- the type of building fabric, *i.e.* **Low** for the poorly-insulated fabric scenario or **High** for the highly-insulated fabric scenario; and
- the household appliances' electrical efficiency, *i.e.* **current efficiency** for current electrical efficiency or **high efficiency** for high electrical efficiency, used in the simulation.

The performance of the system was simulated over an entire calendar year. In the analysis of the results, three distinct periods are considered as the demands on the trigeneration system are different in each: the heating season

(mid-December to mid-March), the cooling season (June to September) and the remaining shoulder months when neither space heating or cooling is required.

Table 4 – Scenarios investigated

Scenario	Type of building fabric scenario	Appliances' electrical efficiency scenario	Building size (Occupancy)	Type of plant configuration	Scope of scenario
$1_{\text{Low/Current efficiency}}$	Poorly- insulated fabric scenario	Current electrical efficiency scenario	3 Household (9 Persons)	Base case plant configuration	Investigate the effect of improving the building fabric and the electrical efficiency of household electrical appliance on micro-trigeneration overall performance
$1_{\text{Low/High efficiency}}$		High electrical efficiency scenario			
$1_{\text{High/Current efficiency}}$	Highly-insulated fabric scenario	Current electrical efficiency scenario			
$1_{\text{High/High efficiency}}$		High electrical efficiency scenario			
$2_{\text{Low/Current efficiency}}$	Poorly- insulated fabric scenario	Current electrical efficiency scenario	6 Household (18 Persons)	Base case plant configuration	By comparing with Scenario 1, investigate the effect of building size and occupancy on micro-trigeneration overall performance
$2_{\text{Low/High efficiency}}$		High electrical efficiency scenario			
$2_{\text{High/Current efficiency}}$	Highly-insulated fabric scenario	Current electrical efficiency scenario			
$2_{\text{High/High efficiency}}$		High electrical efficiency scenario			
$3_{\text{High/Current efficiency}}$	Highly-insulated fabric scenario	Current electrical efficiency scenario	6 Household (18 Persons)	Base case plant configuration with additional chilled water tank	Investigate the effect of including an additional chilled water tank in the plant configuration
$3_{\text{High/High efficiency}}$		High electrical efficiency scenario			
$4_{\text{High/Current efficiency}}$	Highly-insulated fabric scenario	Current electrical efficiency scenario	6 Household (18 Persons)	Base case plant configuration but electricity produced is all exported to the grid	Investigate the financial sensitivity of the system to exporting all the electricity
$4_{\text{High/High efficiency}}$		High electrical efficiency scenario			

A separate explanation is required for Scenario 4, which investigated the effect of exporting all the cogenerated electricity to the grid, rather than using it to satisfy the building's electrical demand and then exporting the excess to the grid, as done in all other scenarios. This reflects the current *Feed-in Tariff (FIT)* arrangement in Malta that currently applies for photovoltaic (*PV*) electricity which is exported to the grid [51]. Any electricity used to satisfy own demand is metered for records through a second separate meter, but is not paid for. Users can opt to sell all of their electricity generated and import electricity from the grid to cover for their own demand [52]. Depending on the difference between the electricity tariff and the *FIT* (in certain circumstances) it may make more financial sense for consumers with low electricity consumption to sell all of the electricity they produce rather than use it

internally. The *FIT* applied in Scenario 4 (explained in more detail in Section 3.3.3.1) works on this principle.

3.1.1 *Post-simulation carbon and financial analysis*

Additional studies were conducted that did not require specific simulations, as these could be undertaken through analysis of the simulation results.

3.1.1.1 *Decarbonisation and grid efficiency improvements*

To account for grid improvement and decarbonisation, a sensitivity analysis was performed for each of the scenarios described in Table 4 where, the grid efficiency (η_{Grid}) and the grid emission factor (e_{Grid}) were varied to represent different grid improvements and changes in the energy mix (*e.g.* due to an increased share of renewable energy).

3.1.1.2 *Varying LPG prices and electricity tariffs*

In assessing the financial performance of a trigeneration system, reference has to be made to the existing financial background. Whereas investment costs are fixed parameters, running costs dictated by variable fuel prices and electricity tariffs have an important effect on the financial feasibility of a system [53]. As with other studies [53, 54], the electricity tariff and the LPG price used in the calculation of the investment criteria of the different scenarios were varied to represent different economic scenarios.

3.2 *Analysis metrics*

The different scenarios simulated were assessed on their energetic, environmental and economic performance using data derived from the raw 1-minute resolution, time-series simulation output. This included the air and water inlet and outlet temperatures and flow rates of all trigeneration system components, fuel consumption (in the case of the CHP unit), the internal temperature in the building zones and other internal parameters of the building such as the solar energy absorbed by each individual zone, *etc.* This data was used, either:

- to obtain high-resolution profiles relating to the building internal conditions (*e.g.* the temperature profile of a particular zone) or the plant network (*e.g.* the trigeneration system electrical output); or
- to obtain average or aggregated system parameters such as the trigeneration system fuel consumption, the supplied thermal energy, *etc.*

3.2.1 *Energetic performance analysis*

The main energetic indicators used in this research were those described by Dorer and Weber [21], specifically, the micro-trigeneration system efficiency, the primary energy consumption (in trigeneration and separate mode) and the primary energy savings (*PES*).

3.2.1.1 System efficiency

The efficiency of the micro-trigeneration system, $\eta_{\mu TRIGEN}$, was calculated using equation (1), defined by Dorer and Weber [21].

$$\eta_{\mu TRIGEN} = \frac{(E_{SH} + E_{SC} + E_{DHW} + E_{Net Demand \mu TRIGEN} + E_{Net Export})100}{(PE_{\mu TRIGEN})} \quad - (1)$$

In equation (1) the numerator represents the energy products produced by the micro-trigeneration system, specifically:

- the supplied thermal energy – the energy supplied for space heating, E_{SH} , the energy supplied for space cooling, E_{SC} , and the energy supplied to provide the domestic hot water, E_{DHW} , and
- the electrical output of the system aggregating the net electrical energy exported, $E_{Net Export}$, and the energy used to satisfy the households' own electrical demand, $E_{Net Demand \mu TRIGEN}$.

The denominator represents the primary energy consumed by the micro-trigeneration system ($PE_{\mu TRIGEN}$) over the same time period; equal to the fuel consumption by the micro-trigeneration system multiplied by the net calorific value of the fuel (for LPG this equates to 46.2 MJ/kg [55]).

3.2.1.2 Comparison with separate generation

Equation (1) does not discriminate between the different exergetic values of the energy products (thermal and electrical) produced [21, 56]. A further method of comparison is using equation (3). This relies on comparing the primary energy consumption of the micro-trigeneration system ($PE_{\mu TRIGEN}$) and the primary energy consumption required to produce the same quantity and quality of products using separate generation ($PE_{SEPARATE}$), calculated using equation (2).

$$PE_{SEPARATE} = \frac{\left(\frac{E_{DHW}}{\eta_{Water}} + E_{Net Demand \mu TRIGEN} + E_{Net Export} + \frac{E_{SC}}{COP}\right)}{\eta_{Grid}} + \frac{E_{SH}}{\eta_{Gas Heater}} \quad - (2)$$

$$PES = \frac{(PE_{SEPARATE} - PE_{\mu TRIGEN})100}{PE_{SEPARATE}} \quad - (3)$$

It was assumed that in separate generation of energy streams, the:

- *DHW* supply was supplied by an electric water heater having an efficiency (including stand-by-losses), η_{Water} , of 85% [57];
- Space heating was supplied by an LPG heating system having an efficiency (including losses due to ancillaries), $\eta_{Gas Heaters}$, of 85% [58]; and
- Space cooling was supplied by a vapour compression chiller with a Coefficient of Performance of 3 [58, 59].

As discussed in section 3.1.1.1 to assess the impact of electricity grid improvements, the grid electrical efficiency, η_{Grid} , was varied between the current value of 25.5% [60] up to the average European grid efficiency of 40% [61] at intervals of 2.5%. Grid electrical efficiency is a measure of the electricity delivered for end-use divided by the energy going into the thermal stations in Malta.

Finally, the amount of primary energy required to produce the net electrical imports, $E_{Net Imports}$, is added to both $PE_{\mu TRIGEN}$ and $PE_{SEPARATE}$ so that when comparing primary energy savings, the result holistically includes the total energy consumption of the building. The adjusted *PES* is shown in equation (4).

$$PES = \frac{([PE_{SEPARATE} + (E_{Net Imports} / \eta_{Grid})] - [PE_{\mu TRIGEN} + (E_{Net Imports} / \eta_{Grid})])100}{[PE_{SEPARATE} + (E_{Net Imports} / \eta_{Grid})]} \quad - (4)$$

3.3.2 Environmental analysis

The environmental performance of the micro-trigeneration system was assessed by calculating the *Emission Savings (ES)* – the CO₂ savings due to the system. The *ES* compares the carbon footprint of the micro-trigeneration system to the carbon footprint associated with producing the equivalent quantity and quality of energy streams using separate generation. The emissions due to the micro-trigeneration ($Emissions_{\mu TRIGEN}$) were calculated using equation (5).

$$(Emissions_{\mu TRIGEN}) = e_{LPG}(PE_{\mu TRIGEN}) \quad - (5)$$

The emission factor of LPG, e_{LPG} , was taken as 0.25 kgCO₂/kWh of primary energy consumed [62]. The equivalent amount of emissions due to separate generation is calculated using equation (6), whilst the saving in emission (*ES*), including the net electrical imports is calculated using equation (7).

$$(Emissions_{Separate}) = [e_{Grid} ((E_{DHW}/\eta_{Water}) + E_{Net Demand} \mu_{TRIGEN} + E_{Net Export} + (E_{SC}/COP)) + e_{LPG}(E_{SH}/\eta_{Gas Heater})] \quad - (6)$$

$$ES = \frac{([Emissions_{SEPARATE} + E_{Net Imports}(e_{Grid})] - [Emissions_{\mu TRIGEN} + E_{Net Imports}(e_{Grid})])100}{[Emissions_{SEPARATE} + E_{Net Imports}(e_{Grid})]} \quad - (7)$$

To factor-in electricity grid improvements the value of e_{Grid} in equations (6) and (7) was varied between the present 1.1 kgCO₂/kWh (calculated on the basis of the total emissions produced by the Maltese electrical system per kWh delivered at end-use [60]) and a future value of 0.5 kgCO₂/kWh, a conservative comparison with the current EU average of 0.4 kgCO₂ per kWh [63]). This was done at 0.1 kgCO₂/kWh intervals.

3.3.3 Economic analysis

According to Biezma and San Cristóbal in [5] the investment criteria typically used to accept or reject a cogeneration project are the Net Present Value, the Internal Rate of Return and the Payback Period. Given that all three investment criteria give similar results vis-à-vis assessing the feasibility of a system only Net Present Value (*NPV*) is used in this study.

3.3.3.1 Financial parameters used in modelling

To calculate the *NPV* the capital investment cost (the aggregated cost of procuring the different plant components); and the cash flow of the project are required. Table 5 shows the *Investment Cost (I)* assumed for each scenario; these are primarily based on the cost of the CHP Unit (and ancillaries), the absorption chiller (and ancillaries) and storage tanks. These have been obtained from manufacturers and can only be considered as indicative, as prices vary depending on factors such as supplier, taxation and freight. The *Investment Cost* for all four scenarios is very similar given that the most expensive components, the CHP unit and the absorption chiller, were the same for all four scenarios.

Table 5 – Investment costs for the different trigeneration systems used in the four scenarios

Scenario	Description	Investment Cost (Euros, €)
1	CHP unit, absorption chiller and storage tanks for the 3 household building	40,267
2	CHP unit, absorption chiller and storage tanks for the 6 household building	40,457
3	CHP unit, absorption chiller, storage tanks for 6 household building with additional chilled water storage tank	41,057

The cash flow (CF) was calculated using equation (8); this includes the financial debits of the system due to the purchase of fuel, revenues gained in exporting excess electricity to the grid and the saved cost from the net demand satisfied by the micro-trigeneration system. Table 6 gives more detail on each individual element of the cash flow calculation.

$$CF = (E_{Net\ Export} \times FIT) + (E_{Total} \times Tariff) - (E_{Net\ Import} \times Tariff) - (E_{Net\ Export} + E_{Net\ Demand\ \mu TRIGEN})MC - (Fuel_{\mu TRIGEN} - Fuel_{SEPERATE})Cost\ of\ Fuel \quad - (8)$$

Table 6 – Explanation of terms in the cash flow equation

Financial component	Explanation
$E_{Net\ Export} \times FIT$	Revenue from net export sales: A source of income is the sale of electricity to the grid at the agreed FIT .
$E_{Total} \times Tariff$, where $E_{Total} = \frac{E_{DHW}}{\eta_{Water}} + \frac{E_{SC}}{COP}$ $+ E_{Net\ Demand\ \mu TRIGEN}$ $+ E_{Net\ Import}$	Total invoiced electricity without trigeneration: Assuming no micro-trigeneration system, E_{Total} includes the cost of all the electricity which would have otherwise been purchased through conventional separate generation sourced electricity.
$E_{Net\ Import} \times Tariff$	Total invoiced electricity with trigeneration: If a micro-trigeneration system is present, only the net electrical imports need to be purchased through conventional separate generation sourced electricity.
$(E_{Net\ Export} + E_{Net\ Demand\ \mu TRIGEN})MC$	Maintenance cost: The maintenance cost is calculated by multiplying the electricity produced by the CHP by the maintenance cost rate (MC) in €/kWh produced.
$(Fuel_{\mu TRIGEN} - Fuel_{SEPERATE})Cost\ of\ Fuel$	Fuel purchasing costs: Given that the fuel type is the same (LPG), the net cost of fuel purchased is calculated by deducting the amount of fuel which would have been used by the space heating in separate generation from the total fuel used by the micro-trigeneration system and multiplying the net amount of fuel by the fuel cost.

The annualised CF calculation uses data from both the technical analysis and financial data. In the analysis that follows, both the electricity tariff and LPG price were varied independently to assess sensitivity and reflect to the elasticity cost of the energy product and prices. Specifically, the following was investigated:

- Whilst keeping the price of LPG constant at the current price (1.19 €/kg), the electricity tariff used to calculate the cash flow of each individual scenario was varied between a very wide range of $\pm 50\%$ of the current tariff (at different intervals: $\pm 10\%$, $\pm 25\%$ and $\pm 50\%$) as shown in Table 7 [64]; and
- Whilst keeping the electricity tariff constant at the current tariff, the price of LPG was varied between the reported market current high (1.19 €/kg +23%) and low (1.19 €/kg -14%) retail price in Malta, at different

intervals.

Table 7 – Electricity tariff bands

Tariff band	Cumulative consumption (kWh)	-50% Current tariff (€/kWh)	Current tariff (€/kWh)	+50% Current tariff (€/kWh)
1	0 - 2,000	0.0805	0.1610	0.2415
2	2,001 - 6,000	0.0865	0.1730	0.2595
3	6,001 - 10,000	0.0945	0.1890	0.2835
4	10,001 - 20,000	0.1800	0.3600	0.5400
5	20,001 & over	0.3100	0.6200	0.9300

In most European countries the concept of a *FIT* is well established. In Germany for example, *FIT* rates for micro-cogeneration are based on whether the cogenerated electricity produced is exported (0.125 €/kWh) or used to satisfy the own demand (0.115 €/kWh) [65]. In the Netherlands *FIT* is augmented by other fiscal incentives such as grants on the investment costs [66]. As explained earlier, in Malta the only existing *FIT* relates to the production of electricity from domestic *PV* systems with a rate of 0.25 € paid per kWh exported [51]. This *FIT* is generally augmented by a grant payable on the capital investment. The *FIT* assumed in this research was assumed to operate on similar principles and was assigned a value of 0.50 €/kWh exported. The *Maintenance Cost (MC)* rate was assumed at a flat rate of 0.012 €/kWh produced [67].

Based on the data obtained, the financial feasibility of each scenario under varying electricity tariffs and LPG prices was then measured using the present worth.

3.3.3.2 Net Present Value - Present Worth

The Net Present Value (*NPV*) encompasses a number of metrics which can be used to assess a project's feasibility [5]. In this research the *Present Worth (PW)* was chosen as the preferred method given that all other *NPV* metrics can actually be considered as derivatives of this method. The *PW* reflects the value of the investment in the future and a project is accepted or rejected if the calculated *PW* value is positive or negative, respectively. Different projects are ranked based on the highest *PW*. *PW* is calculated over an expected project lifetime period of *Y* years using equation (9) presented in [5] by Biezma and San Cristóbal.

$$PW = -I + \sum_{y=1}^Y \left(\frac{CF}{(1+MARR)^y} \right) \quad - (9)$$

In this study the lifetime of the trigeneration project was assumed to be 25 years (quoted in [40] at 80,000 hours, at an average of 3,000 hours per year) whilst the *Minimum Attractive Rate of Return (MARR)*, the rate of return on

investment, was set at 6% as used in a similar project study[5].

5. RESULTS ANALYSIS

5.1 Energetic performance analysis results

5.1.1 Micro-trigeneration system efficiency

Table 8 shows the seasonal and annual micro-trigeneration system efficiencies (%). The gross electricity cogenerated by the system dependent only on the thermal demand (*i.e.* the operating hours of the CHP unit). It follows that for both the household appliance current and high electrical efficiency scenarios that the micro-trigeneration efficiency is the same only the quantity of electricity imported or exported. The results for the different scenarios shown in Table 8 are therefore not differentiated on the basis of the household appliance electrical efficiency.

Table 8 – Seasonal and annual micro-trigeneration system efficiency

Scenario	Scenario description	Micro-trigeneration system efficiency
		Shoulder/Heating/Cooling/Annual $\eta_{\mu TRIGEN}$ (%)
1 _{Low}	3 Household building with poorly-insulated fabric; Base case plant configuration	47.2 / 67.2 / 76.0 / 67.9
1 _{High}	3 Household building with highly-insulated building fabric; Base case plant configuration	47.2 / 65.3 / 68.6 / 63.3
2 _{Low}	6 Household building with poorly-insulated fabric; Base case plant configuration	55.7 / 74.0 / 78.7 / 72.7
2 _{High}	6 Household building with highly-insulated fabric; Base case plant configuration	55.7 / 70.4 / 75.3 / 69.8
3 _{High}	6 Household building with highly-insulated fabric; Base case plant configuration with additional chilled water tank	55.7 / 70.4 / 69.4 / 66.8
4 _{High}	6 Household building with highly-insulated fabric; Base case plant configuration but all electricity is exported	55.7 / 70.4 / 75.3 / 69.8

The highest micro-trigeneration system efficiencies were observed over the cooling period, whilst the lowest were calculated for the shoulder months; this result reflects the fact that the system efficiency benefits from high operating load factors over the cooling season (*approx.* 43%). The poor performance seen over the shoulder months reflects the low operating load factor during the shoulder months (*approx.* 13%), when there is little cooling or heating demand.

Comparing the results obtained for the poorly and highly insulated fabric cases for the 3 and the 6 household building scenarios that improving the building fabric results in decreasing the thermal load therefore a decrease in the system efficiency. Conversely, improving the building fabric provides the opportunity to use a smaller unit thus reducing capital costs. Likewise for a given trigeneration system size, the building size (and the associated thermal demand) is an important factor. Supplying the energy demand of the larger 6-household building results in an increase in the system efficiency.

Considering, the additional chilled water storage tank (Scenario 3_{High}) it can be observed that the additional primary energy required to cover for the extra tank parasitic heat gains results in a 3% reduction in annual efficiency compared to Scenario 2_{High}, which has no tank.

5.1.2 Micro-trigeneration primary energy consumption and comparison with separate generation

5.1.2.1 Comparison assuming current grid network electrical efficiency

Table 9 shows $PE_{\mu TRIGEN}$, the annual primary energy consumed by the micro-trigeneration system, along with the equivalent primary energy required to produce the same energy products in separate generation, $PE_{SEPARATE}$. Also shown are the primary energy savings (PES) attributable to the trigeneration system for each scenario. $PE_{\mu TRIGEN}$, $PE_{SEPARATE}$ and PES are each divided into two categories: 1) with the net electrical imports excluded, and 2) with the net electrical imports included. The distinction is important. Excluding the net electrical imports assesses the net performance of the micro-trigeneration system (in comparison with separate generation) based exclusively on the energy products produced by the micro-trigeneration system. Including the net electrical imports provides a more holistic picture of the PES . Values shown were calculated using the current grid efficiency of 25.5%.

Table 9 – Annual primary energy consumption in trigenerative and separate mode and calculated PES

Scenario Building fabric/Electrical efficiency	Annual $PE_{\mu TRIGEN}$ (kWh)		Annual $PE_{SEPARATE}$ (kWh)		Annual PES (%)	
	Excluding Net Imports	Including Net Imports	Excluding Net Imports	Including Net Imports	Excluding Net Imports	Including Net Imports
	1 _{Low} /Current efficiency	39,936	55,532	75,978	91,574	47.4
1 _{Low} /High efficiency	39,936	51,143	75,978	87,187	47.4	41.3
1 _{High} /Current efficiency	37,878	53,863	70,585	86,569	46.3	37.8
1 _{High} /High efficiency	37,878	49,378	70,585	82,086	46.3	39.8
2 _{Low} /Current efficiency	53,696	82,519	113,362	142,185	52.6	42.0
2 _{Low} /High efficiency	53,696	75,082	113,362	134,748	52.6	44.3
2 _{High} /Current efficiency	49,906	80,167	105,324	135,585	52.6	40.9

2 _{High/High efficiency}	49,906	72,167	105,324	127,584	52.6	43.4
3 _{High/Current efficiency}	53,718	83,045	109,397	138,724	50.9	40.1
3 _{High/High efficiency}	53,718	75,308	109,397	130,987	50.9	42.5
4 _{High/Current efficiency}	49,906	89,745	105,323	145,163	52.6	38.2
4 _{High/High efficiency}	49,906	79,206	105,323	134,624	52.6	41.2

It can be observed that, the *PES* obtained for the different scenarios fall within a small range (*approx.* 6.5%) suggesting that the overall impact of the different operating conditions on the *PES* is low. If, net electrical imports are considered, higher appliance electrical efficiency results in a higher *PES*. Increased the thermal load (*e.g.* when connecting the trigeneration system to a larger building) results in longer operating hours and hence in a higher *PES*. Likewise, improving the building fabric has a negative effect on the system's *PES*. Finally, at the current level of grid efficiency, exporting all the cogenerated electricity and importing all the electricity from the grid (Scenario 4 – as is encouraged by the current *FIT* model in Malta), results in a reduction in *PES* compared to using the cogenerated electricity for on-site demand.

5.1.2.2 Effect of improving the grid network efficiency

Figure 5 shows how the *PES* associated with the micro-trigeneration reduces significantly as the grid efficiency increases. For example, the calculated *PES* of Scenario 1_{Low} (including imports) is *approx.* 40% at 25 % grid efficiency; this drops to 20%, at η_{Grid} of 40%. Further, with improving grid efficiency the different calculated *PES* (*i.e.* including and excluding net electrical imports) converge, because the difference in primary energy required to produce the additional net electrical imports diminishes.

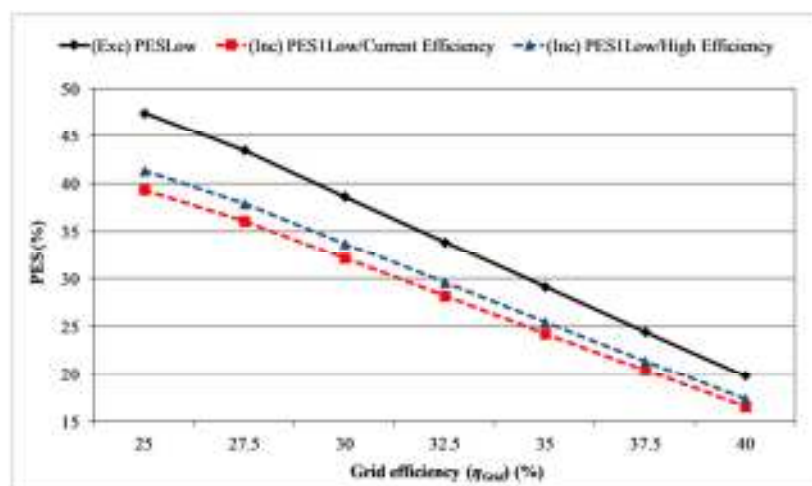

Fig. 5 - Sensitivity of *PES* to grid efficiency (η_{Grid}) (Scenario 1_{Low})

5.2 Environmental analysis results

5.2.1 Micro-trigeneration emissions and comparison with separate generation

5.2.1.1 Comparison with current grid network emission factor

Table 10 shows the annual micro-trigeneration system emissions, $Emissions_{\mu TRIGEN}$, the annual emissions from equivalent, separate generation, $Emissions_{SEPARATE}$, and the annual CO₂ emissions savings of the system (in comparison with separate generation). The grid emission factor, e_{Grid} , used is the current emission factor of the Maltese grid of 1.1 kgCO₂/kWh delivered at end-use.

Table 10 – Micro-trigeneration emissions comparison with separate generation and *ES* (CO₂ Savings)

Scenario	Annual Emissions _{μTRIGEN}		Annual Emissions _{SEPARATE}		Annual <i>ES</i>	
	(kgCO ₂)		(kgCO ₂)		(% CO ₂ Savings)	
	Excluding Net Imports	Including Net Imports	Excluding Net Imports	Including Net Imports	Excluding Net Imports	Including Net Imports
1 _{Low} /Current efficiency	9,963	14,290	20,939	25,267	52.4	43.4
1 _{Low} /High efficiency	9,963	13,072	20,939	24,049	52.4	45.6
1 _{High} /Current efficiency	9,450	13,885	19,469	23,904	51.5	41.9
1 _{High} /High efficiency	9,450	12,640	19,469	22,660	51.5	44.2
2 _{Low} /Current efficiency	13,396	21,393	31,242	39,239	57.1	45.5
2 _{Low} /High efficiency	13,396	19,329	31,242	37,176	57.1	48.0
2 _{High} /Current efficiency	12,451	20,846	29,072	37,467	57.2	44.4
2 _{High} /High efficiency	12,451	18,627	29,072	35,248	57.2	47.2
3 _{High} /Current efficiency	13,402	21,538	30,200	38,337	55.6	43.8
3 _{High} /High efficiency	13,402	19,391	30,200	36,190	55.6	46.4
4 _{High} /Current efficiency	12,451	23,504	29,072	40,125	57.2	41.4
4 _{High} /High efficiency	12,451	20,580	29,072	35,266	57.2	44.7

The same conclusions drawn for the system's *PES* can be extended to the annual CO₂ savings (*ES*). Reducing the system's operational hours by reducing the useful thermal load (*e.g.* due to an improvement in the building fabric) results in a lower *ES*. Decreasing the net electrical imports by improving appliance electrical efficiency increases the *ES* (including imports). The parasitic heat gains to the chilled water tank in the plant system used in Scenario 3_{High} results in reduced *ES*.

Finally, exporting all the electricity and importing all the electricity from the grid as done in Scenario 4_{High}, results in a situation where the *ES* (including imports) is severely reduced.

5.2.1.2 Effect of improving the grid emission factor

Figure 6 typifies how the *ES* varies with improving grid emission factor (e_{Grid}), in this case for Scenario 1_{Low}. As would be expected, improving the grid emission factor results in a reduction in emissions produced in separate

generation, $Emissions_{SEPARATE}$, and a reduction in the micro-trigeneration system's environmental advantage. In this case, considering a possible improvement in the grid emission factor of about 55% (from 1.1 to 0.5 kgCO₂/kWh), it can be observed how the system's annual savings in Scenario 1_{Low} drops to approximately to 1.9% in the cases modelled. For other scenarios, such as Scenario 1_{High}, a grid emission factor of 0.5 kgCO₂/kWh yields a negative saving. For the 3 household building used in Scenario 1_{Low} and Scenario 1_{High}, a grid emissions factor of 0.5 kgCO₂/kWh appears to be the limit beyond which the system loses any environmental advantage over using separate generation.

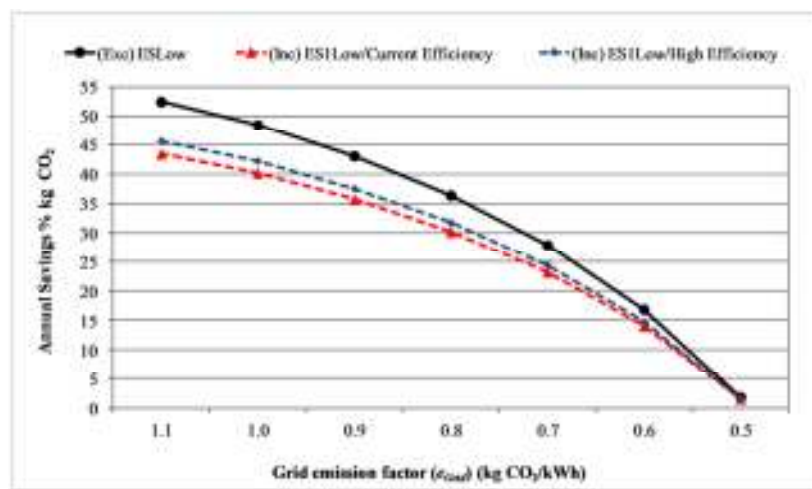

Fig. 6 - Sensitivity of annual ES (CO₂ savings) to the grid emission factor (e_{Grid}) (Scenario 1_{Low})

A Similar result is obtained for the 6 household building. For example, with a poorly-insulated building fabric (Scenario2_{Low}) improving the grid emission factor from 1.1 to 0.5 kgCO₂/kWh results in a drop in the system's annual CO₂ savings to approximately 6%. However, compared to the 3-household building, where the micro-trigeneration system's annual CO₂ savings are practically annulled, in the 6 household building the system's annual CO₂ savings are still relatively significant at the higher grid efficiencies. This suggests that the better demand-matched system in the larger building retains some environmental advantages irrespective of grid emission factor improvements.

5.3 Economic analysis results

5.3.1.1 Present worth assuming a variable electricity tariff scenario

Figure 7 shows the PW calculated for all household sizes with different electricity tariffs, and a constant LPG price of 1.19 €/kg.

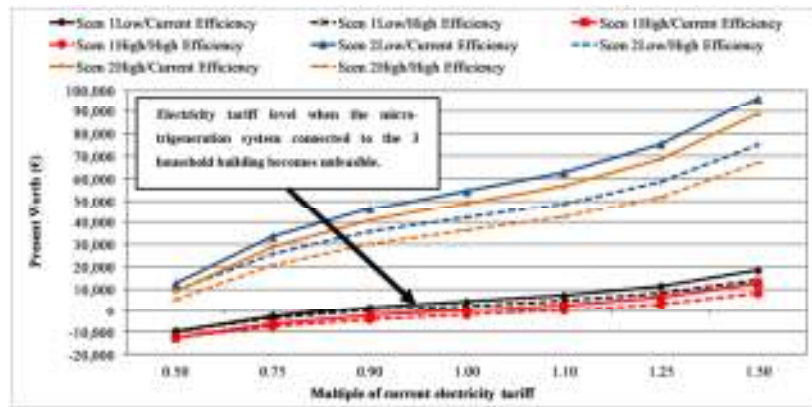

Fig. 7 - PW for Scenarios 1 (3-household building) and 2 (6-household building) for varying electricity tariffs

As electricity costs increase (relative to the LPG price) the financial advantage of the micro-trigeneration increases, due to the greater value of the cogenerated electricity used to satisfy the building's own energy demand. Comparing the *PW* plots for the scenarios in the 3 household building with those in the 6 household building it can be observed how increasing the thermal demand (by connecting the system to a larger building), significantly increases the value of the project. At electricity tariffs lower than the current levels (*approx.* at a value of 0.95 times the current electricity tariff), a trigeneration system in the 3 household building has a negative *PW*, rendering it financially non-viable. The system supplying the 6-household building is financially viable even at lower electricity tariffs.

Any measure aimed at reducing the electrical or thermal energy demand of the building results in a decrease in the *PW* of the trigeneration system. In all cases it can be observed that the *PW* of the project is very sensitive to the appliance electrical efficiency: the difference in *PW* between the current and high appliance electrical efficiency scenarios increases with increasing electricity tariffs. Conversely, the difference in *PW* between fabric scenarios stays reasonably constant throughout the entire range of electricity tariffs: with increasing electricity tariffs, the electrical energy produced by the trigeneration system increases in value at a higher rate than the thermal part.

5.3.1.2 Present worth assuming a variable LPG price scenario

Figure 8 compares the *PW* plots for the cases in the 3 and the 6 household building (Scenarios 1 and 2 respectively) for varying LPG prices and fixed electricity tariffs and shows that the *PW* of the system diminishes with increasing LPG prices. Measures aimed at reducing either the thermal demand (*e.g.* by improving the building fabric) or the electrical demand (*e.g.* by improving the electrical efficiency of appliances), have a detrimental effect on the financial value of a trigeneration project. Similarly, load factors such as that experienced by the plant connected to the 3 household building (Scenario 1) tend to create a situation where the *PW* is very small, bordering

on the negative with increasing LPG prices.

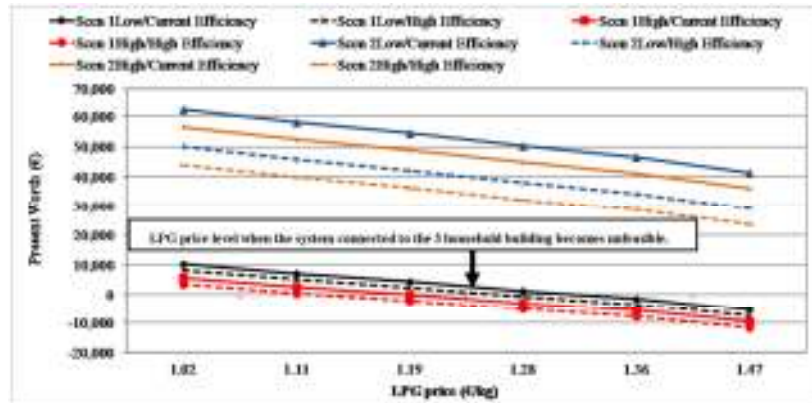

Fig. 8 - PW for Scenarios 1 and 2 for varying gas prices

In the case of the 6 household building the highest difference in PW between the different scenarios is caused by improving the electrical efficiency of appliances. In the case of the 3 household building the highest difference between PW scenarios is that due to the improvement of the building fabric: the reason for this is the difference in the financial value of the energy products.

6 CONCLUSIONS

This paper presented the results of high resolution performance analysis of micro-trigeneration in an energy-efficient residential building under varying operating conditions. The approach adopted makes use of a combined deterministic and sensitivity analysis methodology to analyse the effect, measures aimed at reducing the energy demand of a residential building may have on the energetic, environmental and economic feasibility of a residential micro-trigeneration system. Results indicate that compared to separate generation, micro-trigeneration has the potential to deliver significant primary energy and emission savings (in the region of 40-50%), although the extent of such savings are strongly dependent on the efficiency of the alternative separate generation available. Additionally, decreasing the useful thermal demand leads to a deterioration of the system's energetic, environmental and economic performance. The financial performance of the system is very sensitive to both the selected economic parameters (*FIT*, gas price, electricity tariff, *etc.*) and the operating conditions modelled. In the modelled scenarios some general trends were observed, where the financial performance of the system increased with increasing electricity tariffs and decreased with increasing LPG prices, although to varying degrees depending on the particular scenario.

NOMENCLATURE

Variables

<i>CF</i>	Cash flow (€)
<i>E</i>	Energy product (kWh)
<i>e</i>	Specific emissions (kgCO ₂ /kWh)
<i>FIT</i>	Feed-in tariff (€/kWh)
<i>I</i>	Investment cost (€)
<i>MARR</i>	Minimum attractive rate of return (%)
<i>MC</i>	Maintenance cost (€/kWh)
<i>PE</i>	Primary energy (kWh)
<i>PES</i>	Primary energy savings (%)
<i>PW</i>	Present worth (€)
<i>Y</i>	Expected lifetime (years)

Greek Letters

η	Efficiency
--------	------------

Indices

<i>DHW</i>	Domestic hot water
<i>el</i>	Electrical power
<i>Gas Heater</i>	Variables which refer to the gas heater
<i>Grid</i>	Variables which refer to the grid
<i>LPG</i>	Variables which refer to LPG
<i>μTRIGEN</i>	Micro-trigeneration system
<i>Net Demand μTRIGEN</i>	Electrical energy demand satisfied by the micro-trigeneration system
<i>Net Export</i>	Electrical energy exported to the grid
<i>Net Import</i>	Net electrical energy imported from the Grid
<i>Separate</i>	Separate generation
<i>SC</i>	Space cooling
<i>SH</i>	Space heating
<i>th</i>	Thermal power
<i>Water</i>	Variables which refer to water heating

REFERENCES

- [1] *Directive 2004/8/EC of the European Parliament and of the Council of 11 February 2004 on the promotion of cogeneration based on a useful heat demand in the internal energy market and amending Directive 92/42/EEC*, in *Official Journal of the European Union*
- [2] J. Xu, J. Sui, B. Li and M. Yang, *Research, development and the prospect of combined cooling, heating, and power systems*. *Energy*, 2009. 35(11): pgs. 4361-4367
- [3] D.W. Wu and R.Z. Wang, *Combined cooling, heating and power: A review*. *Progress in Energy and Combustion Science* 2006. 32: pgs. 459-495
- [4] J. Adnot, C. Lopes, M. Orphelin and P. Waide, *Limiting the impact of increasing cooling demand in the European Union - results from a study on room air conditioner energy efficiency*. in *ACEEE Summer Study on Energy Efficiency in Buildings*. 2000. Washington D.C, USA
- [5] M.V. Biezma and J.R. San Cristóbal, *Investment criteria for the selection of cogeneration plants - A state of the art review*. *Applied Thermal Engineering*, 2006. 26(5-6): pgs. 583-588
- [6] E. Cardona and A. Piacentino, *A methodology for sizing a trigeneration plant in Mediterranean areas*. *Applied Thermal Engineering*, 2003. 23: pgs. 1665-1680
- [7] A. Napolitano, G. Franchini, A. Perdichizzi and W. Sparber, *Design Criteria for trigeneration systems coupled with solar thermal collectors*, in *64° Congresso Nazionale ATI*. 2009: L'Aquila, Italy
- [8] F. Polonara, A. Arteconi and C. Brandoni, *Distributed generation and trigeneration: Energy saving opportunities in Italian supermarket sector*. *Applied Thermal Engineering* 2009. 29: pgs. 1735-1743
- [9] I. Beausoleil-Morrison, (2008), *An Experimental and Simulation-Based Investigation of the Performance of Small-Scale Fuel Cell and Combustion-Based Cogeneration Devices Serving Residential Buildings - Final Report of FC+COGEN+SIM The Simulation of Building-Integrated Fuel Cell and Other Cogeneration Systems* in *Annex 42 of the International Energy Agency's Conservation in Buildings and Community Systems Programme*. IEA. Paris, France
- [10] E. Entchev, (2012), *Integration of micro-generation and related energy technology in buildings - Annex 54 of the International Energy Agency*. IEA. Paris, France
- [11] M. Pehnt, M. Cames, C. Fischer, B. Praetorius, L. Schneider, K. Schumacher and J.P. Voß, *Micro-Cogeneration: Towards Decentralized Energy Systems* ed. Springer. 2006, The Netherlands
- [12] K.K. Khatri, D. Sharma, S.L. Soni and D. Tanwar, *Experimental investigation of CI engine operated Micro-Trigeneration system*. *Applied Thermal Engineering*, 2010. 30(11-12): pgs. 1505-1509
- [13] G. Angrisani, A. Rosato, C. Roselli, M. Sasso and S. Sibilio, *Experimental results of a micro-trigeneration*

- installation*. Applied Thermal Engineering, 2012. 38: pgs. 78-90
- [14] L. Lin, Y. Wang, T. Al-Shemmeri, T. Ruxton, S. Turner, S. Zeng, J. Huang and Y. He, *An experimental investigation of a household size trigeneration*. Applied Thermal Engineering, 2007. 27: pgs. 576-585
- [15] X.Q. Kong, R.Z. Wang, J.Y. Wu, X.H. Huang, Y. Huangfu, D.W. Wu and Y.X. Xu, *Experimental investigation of a micro-combined cooling, heating and power system driven by a gas engine*. International Journal of Refrigeration, 2005. 28: pgs. 977-987
- [16] M.S. Rocha, R. Andreos and J.R. Simões-Moreira, *Performance tests of two small trigeneration pilot plants*. Applied Thermal Engineering, 2012. 41: pgs. 84-91
- [17] H-M. Henning, T. Pagano, S. Mola and E. Wiemken, *Micro trigeneration system for indoor air conditioning in the Mediterranean climate*. Applied Thermal Engineering, 2007. 27: pgs. 2188-2194
- [18] J. Wang, Z. Zhai, Y. Jing and C. Zhang, *Influence analysis of building types and climate zones on energetic, economic and environmental performances of BCHP systems*. Applied Energy, 2011. 88(9): pgs. 3097-3112
- [19] M. Carvalho, L.M. Serra and M.A. Lozano, *Geographic evaluation of trigeneration systems in the tertiary sector. Effect of climatic and electricity supply conditions*. Energy, 2010. 36(4): pgs. 1931-1939
- [20] K.C. Kavvadias, A.P. Tosios and Z.B. Maroulis, *Design of a combined heating, cooling and power system: Sizing, operation strategy selection and parametric analysis*. Energy Conversion and Management, 2010. 51: pgs. 833-845
- [21] V. Dorer and A. Weber, (2007), *Methodologies for the Performance Assessment of Residential Cogeneration Systems - A Report of Subtask C of FC+COGEN+SIM The Simulation of Building-Integrated Fuel Cell and Other Cogeneration Systems in Annex 42 of the International Energy Agency's Conservation in Buildings and Community Systems Programme*. IEA. Paris, France
- [22] ESRU, (2005), *ESP-r*. Energy Systems Research Unit, Department of Mechanical and Aerospace Engineering, University of Strathclyde, Glasgow, UK
- [23] M. Stokes, (2004), *Removing barriers to embedded generation: a fine-grained load model to support low voltage network performance analysis*. Doctoral Thesis - Institute of Energy and Sustainable Development, De Montfort University, Leicester, UK
- [24] A. Hawkes and M. Leach, *Impacts of temporal precision in optimising modelling of micro-Combined Heat and Power*. Energy, 2005. 30: pgs. 1759-1779
- [25] T.L. McKnight and D. Hess, *Climate Zones and Types: Mediterranean Climate (Csa, Csb)*, in *Physical Geography: A Landscape Appreciation*. 2007, Prentice Hall: Upper Saddle River, NJ. pgs. 221-223
- [26] S.P. Borg, N.J. Kelly, and K. Rizzo. *Modelling and simulating the effects of the use of insulated building*

- fabric in a multi-story Maltese residential building.* in *Sustainable Energy 2012: The ISE Annual Conference*. 2012. Qawra, Malta
- [27] A. Abela, M. Hoxley, P. McGrath and S. Goodhew, *A comparative study of the implementation of the energy certification of residential properties in Malta in compliance with the Energy Performance of Buildings Directive*. 2011, School of Architecture, Design and the Built Environment, Nottingham Trent University: Nottingham, UK
- [28] National Statistics Office, *Census of Population and Housing 2005, Volume 1: Population*. 2007, National Statistics Office, Valletta, Malta
- [29] ASHRAE, *The 2009 ASHRAE Handbook - Fundamentals*. Owen, Editor. (2009). American Society of Heating Refrigerating and Air Conditioning Engineers, Chapter 17 - Residential Cooling and Heating Load Calculations
- [30] M.V. Tejedor, R.N. Farrugia and C. Yousif, *Energy Study in a Maltese Household*, in *World Renewable Energy Congress*, Sayigh, Editor. 2008. pgs. 757-762
- [31] E. Giama, A.M. Papadopoulos and D. Anastaselos, *An assessment tool for the energy, economic and environmental evaluation of thermal insulation solutions*. *Energy and Buildings* 2009. 41: pgs. 1165-1171
- [32] M. D’Orazio, C. Di Perna and E. Di Giuseppe, *The effects of roof covering on the thermal performance of highly insulated roofs in Mediterranean climates*. *Energy and Buildings*, 2010. 42: pgs. 1619-1627
- [33] P.A. Pilavachi, Y. Nikolaidis and A. Chletsis, *Economic evaluation of energy saving measures in a common type of Greek building*. *Applied Energy*, 2009. 86: pgs. 2250-2559
- [34] *Directive 2002/91/EC of the European Parliament and of the Council of 16 December 2002 on the energy performance of buildings*, in *Official Journal of the European Union*
- [35] V. Buhagiar, (2007), *Technical Improvement of Housing Envelopes in Malta*. [Access Date: 30/11/2010]; Available from: www.coste16.org/downloads/FACADES_AND_ROOFS/Boek_04-09.pdf
- [36] Building Regulations Office, (2003), *Malta Building Regulations, Part F - Conservation of Fuel, Energy and natural Resources*, in *Minimum Requirements on the Energy Performance in Buildings*, Ministry for Resources and Rural Affairs: Malta
- [37] J. Jorge, J. Puigdoemench and A. Cusido *A practical tool for sizing optimal shading devices*. *Building and Environment*, 1993. 28(1): pgs. 69-72
- [38] I. Beausoleil-Morrison, A. Ferguson, W. D’haeseleer and N.J. Kelly, (2007), *Experimental Investigation of Residential Cogeneration Devices and Calibration of Annex 42 Model - A Report of Subtask B of FC+COGEN+SIM The Simulation of Building-Integrated Fuel Cell and Other Cogeneration Systems*, in

Annex 42 of the International Energy Agency: Conservation in Buildings and Community Systems Programme. IEA. Paris, France

- [39] Baxi- SenerTec UK, (2010), *DACHS Mini-CHP Brochure*. Baxi-SenerTec. Birmingham, UK
- [40] Baxi-SenerTec UK, (2010), UK Webpage. [Accessed: 29/03/2011];
Available from: <http://www.baxi.co.uk/products/DACHS.htm>
- [41] C. Volker, (2009), *Sonnenklima Suniniverse - Solar cooling product information and experience*. in *Derbi Conference*. Perpignan, France
- [42] S.P. Borg and N.J. Kelly, *The development and calibration of a generic dynamic absorption chiller model*. *Energy and Buildings*, 2012. 55: pgs. 533-544
- [43] Vaillant, *High performance unvented stainless steel cylinder range*. 2012
- [44] S.P. Borg and N.J. Kelly, *The effect of appliance energy efficiency improvements on domestic electric loads in European households*. *Energy and Buildings*, 2011. 43(9): pgs. 2240-2250
- [45] REMODECE Partners. *REMODECE Database - Residential Monitoring to Decrease Energy Use and Carbon Emissions in Europe (IEEA Program Funded Project)*. [Database] 2008 [Accessed 01/12/2009];
Available from: <http://www.isr.uc.pt/~remodece/database/login.htm>
- [46] I. Knight, N. Kreutzer, M. Swinton, M. Manning and H. Ribberink, (2007), *European and Canadian non-HVAC Electric and DHW Load Profiles for use in Simulating the Performance of Residential Cogeneration Systems - A Report of Subtask A of FC+COGEN+SIM The Simulation of Building-Integrated Fuel Cell and Other Cogeneration Systems in Annex 42 of the International Energy Agency: Conservation in Buildings and Community Systems Programme*. IEA. Paris, France
- [47] U. Jordan and K. Vajen, *Realistic Domestic Hot-Water Profiles in Different Time Scales*, in *Solar Heating and Cooling Program of the International Energy Agency (IEA SHC), Task 26: Solar Combisystems*. 2001, Solar Heating and Cooling Program of the International Energy Agency (IEA SHC), Task 26: Solar Combisystems
- [48] U. Jordan and K. Vajen, *DHWcalc: Program to generate domestic hot water profiles with statistical means for user defined conditions*, in *ISES Solar World Congress*. 2005: Orlando, USA
- [49] S.P. Borg, C.I. Yousif, and R.N. Farrugia. *Investigation of domestic solar water heaters installations in Malta*. in *Renewable Energies in Malta and Beyond*. 2005. Salina, Malta
- [50] S.A. Kalogirou, *Use of TRNSYS for modelling and simulation of a hybrid pv-thermal solar system for Cyprus*. *Renewable Energy*, 2001. 23 pgs. 247-260
- [51] Malta Resources Authority, (2011), *Feed-in Tariffs (Electricity generated from solar photovoltaic*

installations) - Legal Notice 70 of 2011. Malta Resources Authority, Marsa, Malta

- [52] Malta Resources Authority, (2011), *Feed-in Tariffs Scheme 2011 - Information to stakeholders* - Online Presentation; Malta Resources Authority, Marsa, Malta [Accessed: 15/01/2012]; Available from: <http://www.mra.org.mt/Downloads/licences/Energy%20Performance%20assessment,%20electricity%20and%20RES/FIT%20Scheme%202010%20-%20Information%20meeting.pdf>
- [53] H. Ren, W. Gao and Y. Ruan, *Optimal sizing for residential CHP system*. Applied Thermal Engineering, 2008. 28: pgs. 514-523
- [54] P. Colonna and S. Gabrielli, *Industrial trigeneration using ammonia-water absorption refrigeration systems (AAR)*. Applied Thermal Engineering 2003. 23: pgs. 381-396
- [55] International Energy Agency, "*Energy Statistics Manual*", ed. Mandil. 2004, IEA. Paris, France
- [56] E. Macchi, S. Campanari and P. Silva *La Microgenerazione a gas naturale*, ed. Polipress. Vol. Scienza e tecnologia per l'energetica. 2005, Milano
- [57] DEFRA, (2008) *Policy Brief: Improving the energy performance of domestic heating and hot water systems*, in *Volume in Series "Market Transformation Programme"*
- [58] W.L. Angel, *HVAC Design Sourcebook*. 2011: McGraw-Hill Professional; 1st Edition
- [59] P. Fragiaco, P. Arcuri and G. Florio, *A mixed integer programming model for optimal design of trigeneration in a hospital complex*. Energy 2007. 32 pgs. 1430-1447
- [60] Enemalta Corporation, (2011), *Annual Report 2009 and Financial Statements 2008*. Enemalta Corporation Marsa, Malta. [Accessed: 10/09/2011]; Available from: <http://www.enemalta.com.mt/enemaltastorage/images/files/annual%20reports/annual%20report%202009%20and%20financial%20statement%202008.pdf>
- [61] *Directive 2006/32/EC of the European Parliament and of the Council of 5 April 2006 on energy end-use efficiency and energy services*, in *Official Journal of the European Union*.
- [62] A. Herold, (2003), *Comparison of CO₂ emission factors for fuels used in Greenhouse Gas Inventories and consequences for monitoring and reporting under the EC emissions trading scheme* - ETC/ACC Technical Paper 2003/10. European Topic Centre on Air and Climate Change
- [63] EEA, (2012), *Trends in energy GHG emission factors and % renewable electricity (EU-27)*. [Accessed:10/12/12]; Available from: <http://www.eea.europa.eu/data-and-maps/figures/trends-in-energy-ghg-emission>
- [64] Enemalta Corporation, (2010), "*Electricity Tariffs*"; [Accessed: 26/10/2011]; Available from: <http://www.enemalta.com.mt/index.aspx?cat=2&art=5&art1=9>

- [65] D. Shaw, (2009), *CHP comes of age* - Online Presentation. [Accessed: 07/04/2012]; Available from:
<http://www.cibseashrae.org/presentations/Shaw0209.pdf>
- [66] T. Kerr, (2007), *CHP/DHC Country Scorecard: The Netherlands*, in *The International CHP/DHC Collaborative*. International Energy Agency
- [67] I. Knight and I. Ugursal, (2007), *Residential Cogeneration Systems: A Review of the Current Technologies - A Report of Subtask A of FC+COGEN+SIM The Simulation of Building-Integrated Fuel Cell and Other Cogeneration Systems in Annex 42 of the International Energy Agency: Conservation in Buildings and Community Systems Programme*. IEA. Paris, France