

Techno-economic analysis of on-grid biomass renewable energy power station: A case study in Caribbean region of Colombia

C H Acevedo¹, G E Valencia² and Y D Cardenas³

¹ Departamento de Ingeniería Mecánica, Universidad Francisco de Paula Santander, San José de Cúcuta, Colombia

² Efficient Energy Management Research Group, Universidad del Atlántico, Barranquilla, Colombia

³ Grupo de Investigación GIOPEN, Universidad de la Costa, Barranquilla, Colombia

E-mail: ycardena6@cuc.edu.co

Abstract. In this article a techno-economic study of an Electric-Biomass on-grid power plant is presented, in order to compare the performance and the operating annual cost under some types of biogas produced from poultry, bovine and porcine manure, and solid urban organic waste, using the Homer[®] software to develop many solutions. Certainly, the best set up had the maximum combined renewable energy with a minimum electric consumption from the grid. The scheme was integrated by two 500kW biogas-powered electric generator on grid to supply an average energy of 1401.6kW, with an annual operating cost of \$2.09 million when the energy supply is electric. Results presented a significant operational cost reduction when the biogas generator is operating on grid, finding an 8.61% of cost decrease using biogas generated from poultry, bovine and porcine manure, and a 10.53% of cost decrease using biogas from solid urban organic waste from centers and grocery market places at Caribbean Region of Colombia.

1. Introduction

The annual potential of energy production from biomass resource in Colombia is projected to be around 16.260MWh [1], the biomass in Colombia is a plentiful and oldest source of energy in the world. Colombia in particular is a country generator of biomass [2], where the biomass considered is composed of the organic matter of including wood, agricultural residues, human and animal wastes. It is a mixture of the some gases like methane (CH₄) and carbon dioxide (CO₂), produced by micro-organisms in the deficiency of oxygen [3] Renewable energy technologies play an important role on the economic growth of any country [4], and their use had increased due to fuel cost and the energy crisis around the world, becoming an interesting alternative in the energy transitions in this decade [5]. These biomass energy techniques and equipment are environment-friendly, uncontaminated and can be used at micro stages [6]. Non-conventional energy plants based on micro-grid schemes are considered as the best alternative to produce agricultural farms self-regulating of the traditional grid systems and can provide energy on the continuous basis without producing any disturbance [7–9].

Different study to the base of techno-economic analysis for example [10] achieved ideal development and viability investigation for the rural communal by bearing in mind photovoltaic, hydro, biomass and diesel as energy resources to generate power for the highest capacity of 55.49kW. They executed simulations with HOMER[®] involving a 6kW biogas generator, 60kW PV, 16kW biomass, and 10kW



diesel generator with storage batteries is a more suitable option for the studied area [11], other studies were performed a cost comparison analysis of the grid-based supply to the health center in a rural area with the fuel cell based generation system using HOMER®. [12] This study concluded that the electric grid supply is cheaper form an off-grid system than a grid-based amount if it is beyond 44km distance. This study was performed for a small entity but not for a rural community. Similarly, Anand Singh et al [13] another study was conducted considering the rural location who considered different way of electricity generation such as solar energy, wind energy and diesel engine generator in many places in Nigeria with the assistance of HOMER® [14].

HOMER® is an interactive software normally used to simulate and improve energy power plant using renewable energies resource by mean of different kinds of generators such as internal combustion engine, gasifier, and hydrokinetic turbines. HOMER® allow to estimate the optimal scheme from a multiple proposal through an economic study and pollution analysis [8,15-16]. The non-conventional energy generation strategies are determined has one of the top alternative for some fields of the energy supply systems, through simulations using HOMER® [7,17].

The purpose of this study is based on the need of teach the advantages of the biomass as a fuel resource, to replace the hydrocarbons and fossil fuels which are dangerous to the environment.

2. Methodology

The behavior of the energy demand considered for the numerical study presented a scaled average of 33.640kWh/d throughout the year with a peak value of 7160.8kW. It was considered a power supply system through two biogas generators of 500kW each, and a biodigester such as shown schematically in Figure 1, additionally, the electricity grid is used to deliver the energy needed to complement the generation of biogas generation equipment. These biogas generators operate parallel to the grid, in such a way that if the generation with the generators is sufficient, the grid complements so that the system operates correctly.

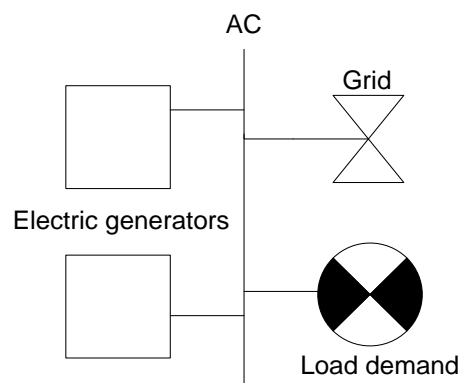

Figure 1. System scheme.

The fuel used for the proper operation of biogas generators, which is produced by anaerobic digestion of collected biomass, which can be processed from livestock manure, either from the poultry, beef or pork sector. Similarly, biomass can be obtained from urban organic waste available in marketplaces, pruning and shopping centers in the city. The availability of these resources has been considered in this study, as shown in Table 1, given that if the amount of biomass available is not adequate for the generation of biogas needed, the total energy generated by the non-conventional system will not be sufficient and the network will complement the generation. Therefore, the operational cost of the arrangement will be much higher, which justifies the fact that the thermal energy generation systems on the Colombian Caribbean coast use diesel and coal as a source for their operation.

Biogas is a fuel obtained through equipment and processes where biodegradation reactions of biomass from different organic sources occur, through the intervention of microorganisms in anaerobic

environments. The product obtained normally contains a mixture of methane with concentration between 40% and 70%, carbon dioxide, in addition to the presence of other gaseous compounds such as hydrogen, nitrogen, sulfur hydrogen and oxygen.

Table 1. Resource availability; where CC&MP is commercial centres & market places.

Availability (ton/day)	Livestock sector			Urban organic solid waste	
	Poultry	Bovine	Porcine	CC&MP	Pruning
	327.49	3063.71	69.9	26.77	5.45

The software used for the simulation of the proposed case studies was HOMER®, which can analyze and optimize the operational conditions for each proposed system, then the software compares the results to establish which of all systems is optimal based on operational cost and emissions.

HOMER® use some fundamental equations (Equation 1 to Equation 3) to estimate the total Net Present Cost (NPC) to calculate the life cycle cost of the array, also the Capital Retrieval Factor (CRF), and the Energy Cost (COE), which is the mean cost per kilowatt-hour (\$/kWh) of energy produced by the system.

$$NPC(U\$) = \frac{TAC}{CRF} \quad (1)$$

Where TAC is the total annualized cost,

$$CRF(U\$) = \frac{(1+i)N}{(1+i)(N-1)}, \quad (2)$$

Where N is the number of years, and i is the annual real interest rate (percentage).

$$COE(U\$) = \frac{Can, co}{E}, \quad (3)$$

Where Can, co is the annual total cost, $U\$$. E is the total electricity consumption in $kWh/Year$ [18].

3. Results analysis

Considering a random variability of the 10% day to day, with a scaled annual average of 33.64kWh/d, a peak of 7.16kW and an average of 1.4kW, the monthly average load profile was calculated for 25 years of simulation. A typical annual load profile is shown on Figure 2.

It is important to highlight that the monthly average load profile is just for one of those workstations, considering that this simulation is based on a set of workstation buildings, then the load profile still been the same, the only difference lies in the number of workstations standing in the buildings, that increase the scale of the load profile.

A bar-chart with the total operational cost for each resource sector is necessary to determine which of these fuels are the optimal, through an economic analysis, as is shown on the Figure 3.

It can be seen that the CC&MP sector presents the lower operational cost for a simulation of 25 years, this could be by two reasons, the CC&MP sector presents the lower price by unit (4.45€/ton) and presents an availability required to the right function of the system, therefore the amount of biogas is sufficient and the grid do not work a longer time, it is necessary to highlight that the grid present a price of 0.15€/kWh. Likewise, the livestock sector presents the same operational cost because all those sectors have an availability necessary to replace the grid works completely.

Figure 3 shows a comparison of the annual operational cost for each type of biomass resource, to determine which sector is the optimal to implement in a short period of time. Where it can be seen that

the CC&MP is present as the best option to choose, his annual and total operational cost is the lowest of this simulation; however, this biomass resource cannot replace completely the grid works. By the way, if the system works only with the grid supply, the operational costs for a simulation of one year or 25 years are the highest and presents a dangerous greenhouse gas production for the environment. It can be seen that the CC&MP sector presents the lower operational cost for a simulation of 25 years, this could be by two reasons, the CC&MP sector presents the lower price by unit (4.45€/ton) and presents an availability required to the right function of the system, therefore the amount of biogas is sufficient and the grid do not work a longer time, it is necessary to highlight that the grid present a price of 0.15€/kWh. Likewise, the livestock sector presents the same operational cost because all those sectors have an availability necessary to replace the grid works completely.

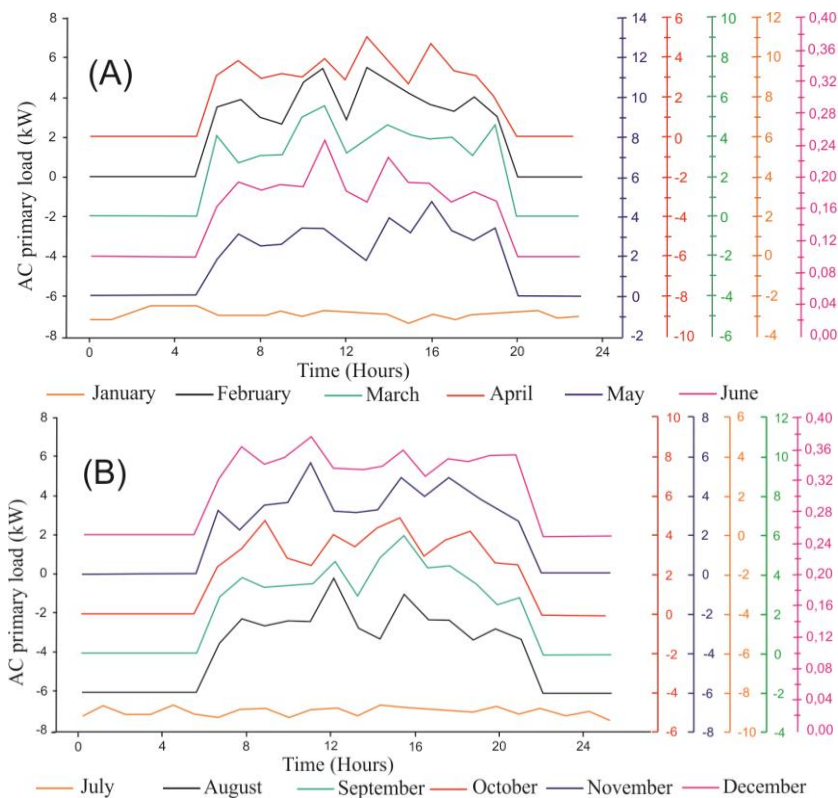

Figure 2. Monthly average load profile.

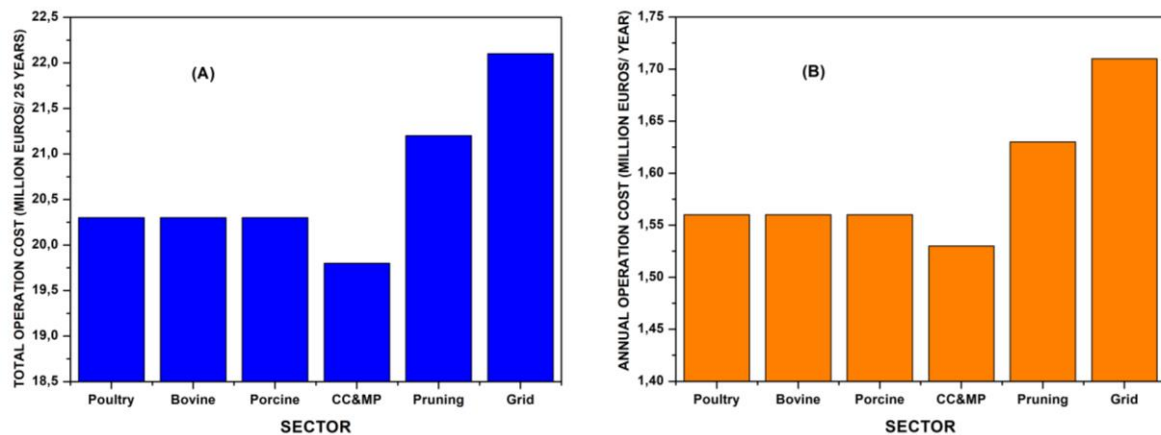

Figure 3. (a) Total operation cost; (b) Annual operation cost.

A bar-chart with the percent of operational cost reduction for each biomass resource, respect the grid works is shown on the Figure 4, to determine the optimal option through an economic analysis.

Figure 4 presents the CC&MP sector as the best of this simulation, through an economic analysis, but it is important to highlight that this sector present more greenhouse gas emissions than the livestock sector.

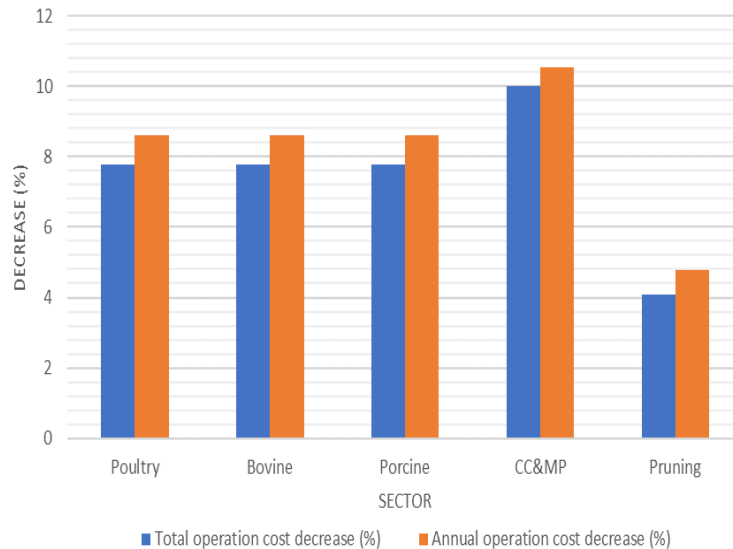

Figure 4. Operation cost decrease for each type of biomass sector, with grid as the nominal value.

4. Conclusions

Replace the grid work in a system could represent a great decrease of the greenhouse gas emission, however the operational cost could be higher than the minimal possible value. Therefore, it is recommended that the renewable fraction of the system do not be 100% and replace completely the grid work. The integration of different types of electricity production is a real option to diversify the energy mix of developing countries, where the production of biomass can be a source of income at very competitive prices.

The projections depend a lot on the economic stability, the reduction in the consumption of fossil fuels and the promotion of biomass as an energy resource. Therefore, it should be clarified that this type of network is not disconnected from the traditional generation network, since generation using biomass is a backup for traditional energetic mix.

Acknowledgments

This research was supported by the Engineering Faculty of Universidad del Atlántico. G. Valencia is supported by the Efficient Energy Management Research Group Kai, C. Acevedo works for the Engineering Faculty of Universidad Francisco de Paula Santander and Y. Cardenas is supported by the GIOPEN Research Group from the Energy Department of Universidad de la Costa.

References

- [1] Gonzalez M, Morini M, Pinelli M, Ruggero P, Venturini M 2014 Methodology for estimating biomass energy potential and its application to Colombia *Appl. Ener.* **136** 781-796
- [2] Ramirez N, Faaij A 2018 A review of key international biomass and bioenergy sustainability frameworks and certification systems and their application and implications in Colombia *Renew. and Susta. Ener. Revie* **96** 460-478
- [3] Perera K, Rathnasiri P, Senarath S, Sugathapala A, Bhattacharya S and Abdul Salam P, 2005 Assessment of sustainable energy potential of non-plantation biomass resources in Sri Lanka *Biom. and Bioe.* **29(3)** 199-213

- [4] Amoresano A, Langella G and Sabino S, 2015 Optimization of solar integration in biomass fuelled steam plants *Ener. Proc.* **81** 390-398
- [5] Sen R and Bhattacharyya S, 2014 Off-grid electricity generation with renewable energy technologies in India: An application of HOMER *Renew. Ener.* **62** 388-398
- [6] Chen J, Shaoyu L, Zhang Z, Zhao X, Li, X 2018 Environmentally friendly fertilizers: A review of materials used and their effects on the environment *Scien. of the Tot. Envir.* **613-614** 829-839
- [7] Haratian M, Tabibi P, Sadeghi M, Vasegi B, Poustdouz A 2018 Renewable energy solution for stand-alone power generation: A case study of KhshU Site-Iran *Renew. Ener.* **125** 926-935
- [8] Zhang F, Johnson D, Wang J and Yu C, 2016 Cost, energy use and GHG emissions for forest biomass harvesting operations *Ener* **114** 1053-1062
- [9] Dafnomilis I, Duinkerken M, Junginger M, Lodewijks G and Schott D, 2018 Optimal equipment deployment for biomass terminal operations *Trans. Res. Part E: Log. and Trans. Revi* **115** 147-163
- [10] Bhattacharyya S, 2015 Mini-grid based electrification in Bangladesh: Technical configuration and business analysis *Renew. Ener* **75** 745-761
- [11] Bhatt A, Sharma M and Saini R, 2016 Feasibility and sensitivity analysis of an off-grid micro hydro-photovoltaic-biomass and biogas-diesel-battery hybrid energy system for a remote area in Uttarakhand state, India *Renew. and Sust. Ener. Revi.* **61** 53-69
- [12] Munuswamy S, Nakamura K and Katta A, 2011 Comparing the cost of electricity sourced from a fuel cell-based renewable energy system and the national grid to electrify a rural health centre in India: A case study *Renew. Ener.* **36(11)** 2978-2983
- [13] Singh A, Baredar P and Gupta B, 2015 Computational Simulation & optimization of a solar, fuel cell and biomass hybrid energy system using HOMER Pro Software *Proce. Engi.* **127** 743-750
- [14] Olatomiwa L, Mekhilef S, Huda A and Ohunakin O 2015 Economic evaluation of hybrid energy systems for rural electrification in six geo-political zones of Nigeria *Renew. Ener.* **83** 435-446
- [15] Barrozo F, Valencia G and Cardenas Y, 2018 Computational simulation of the gas emission in a biomass on grid energy computational simulation of the gas emission in a biomass on grid energy system using HOMER Pro Software *Chem. Eng. Trans.* **65** 265-270
- [16] Nguyen B and Rittmann B, 2018 Low-cost optical sensor to automatically monitor and control biomass concentration in microalgal cultivation *Alg. Rese.* **32** 101-106
- [17] De la Cruz J, Valencia G and Vanegas M, 2018 Estudio estadístico de la velocidad y la dirección del viento en los departamentos de Atlántico y Bolívar en Colombia *Ingeniare. Revista chilena de ingeniería* **26(2)** 319-328
- [18] Fahmy F, Farghally H and Ahmed N, 2014 Photovoltaic-biomass gasifier hybrid energy system for a poultry house *Inter. Jour. Of Mod. Eng. Rese (IJMER)* **4(8)** 51-62