

MICHIGAN PUBLISHING. UNIVERSITY OF MICHIGAN PRESS.

# A mid-Republican House from Gabii

---

Author's Proof of Chapter: The Ceramic Evidence

Volume Editors: Rachel Opitz, Marcello Mogetta, and Nicola Terrenato .  
Chapter Author: Antonio Ferrandes  
10/12/2016

DOI: 10.3998/mpub.9231782

ISBN: 978-0-472-99900-2

Ferrandes, A. (2016) The Ceramic Evidence. In Opitz, R., Mogetta, M. and Terrenato, N. *A mid-Republican House from Gabii*. Michigan Publishing. University of Michigan Press: Ann Arbor, MI.

## The ceramic evidence

### The stratigraphic deposits and their chronology – by A. Ferrandes (translated by M. Mogetta)

#### Introduction

The excavations carried out within the urban area of the ancient site of Gabii have uncovered a complex sequence of occupation spanning from the Mid-Republican period to the early Imperial period. The study of the pottery assemblage recovered from these stratigraphic deposits contribute significantly to our understanding of the material culture, society and economy of the Latin town at that time. Until recently, the only available corpora of ceramics from contemporary contexts at Gabii were those from the votive deposits at the sanctuary of Iuno (Almagro Gorbea 1982), from the extraurban “Santuario Orientale” (Musco, Pilo 2006), and from the rural shrine at Ponte di Nona (Potter 1989), which is located about 3 miles from the urban center, and which has been interpreted as a healing sanctuary (see Musco 2006, with further bibliography). In all cases, then, we are dealing with sanctuary sites, for which the particular use and function of the objects resulted in the overrepresentation of finewares and terracottas as opposed to common and coarse wares. Useful comparanda for the analysis of vessels used for food preparation, cooking and storage, which is an underrepresented class in the published assemblages from Gabii, are provided by the finds from recent developer-driven archaeology projects in the east suburban sprawl of Rome. A number of dumping sites dating to the middle and late Republican period have been identified as a result of these projects, whose timely publication (Bertoldi 2011) provides us with an updated repertoire of the main shapes and types of utilitarian pottery then common in the sector of Rome’s suburbium closer to Gabii.

The study of the materials collected from the Tincu house allows us to chart the consumption and discard patterns associated with the occupation of domestic contexts (either the house itself or the neighborhood), although nothing can be said about specific classes of materials (particularly precious materials or stones) that only rarely get lost or dumped.

Table 18 shows the distribution of pottery fragments (sherd counts) by phase. The deposits have been distinguished into: occupation levels (A), leveling layers whose function was to raise the surface to create new floors (B, H); structural features such as fills of foundation trenches or dumps connected with the construction of new walls (C, E, I, K); floor preps, floors and pavements (D, F, J); abandonment levels of individual features, such as drains and sewers, or rooms (G, L); spoliations (M); natural deposits (N); layers with uncertain function (Q). Thus, the analysis of the materials has proceeded in parallel with the analysis of the stratigraphic sequence, emphasizing the activities associated with the stratigraphy and structure, and paying particular attention to both the relative proportions and combinations of the

different pottery classes. Further, the study by type of formation process has proved essential for the identification of residues or intrusions.

| Phase    | Feature                          | Assemblage  | SU  | frgs.                        | Sector                       |                                  |
|----------|----------------------------------|---|---|------------------------------|------------------------------|----------------------------------|
| Phase 0  | A                                | Occupation level?   | A1. Leveling layer with tile structure  | 1416                         | 25                           |                                  |
| Phase 1A | B                                | Levelling layers  | B1. Dumps predating the house   | 1205, 1399                   | 365                          | Rooms 3, 5                       |
|          | C                                | Construction  | C1. Fills of foundation trench and/or construction cuts                               | 1440, 1465                   | 16                           | South and East sides of property |
|          | D                                | Floors  | D1. Floor preparation for SU 1178<br>D2. Finished floor surface of courtyard          | 1180<br>1173                 | 53<br>137                    | Room 1<br>Courtyard              |
| Phase 1B | E                                | Construction  | E1. Leveling layers   | 1424, 1446                   | 37                           | Southern addition                |
|          | F                                | Floors  | F1. floor preparation   | 1428                         | 151                          | Southern addition                |
|          | G                                | Obliteration/Abandonment                                      | G1. Fill of drain 1322  | 1279=1385                    | 3873                         | East side of property            |
| Phase 2  | H                                | Levelling layers  | H1. Dumps to raise floor level  | 1386, 1443, 1457             | 788                          | Room 6                           |
|          | I                                | Construction  | I1. Fill associated with wall SU 1186   | 1182                         | 30                           | Coutyard                         |
|          |                                  |   | I2. Reorganization of access to Room 6  | 1423                         | 177                          | Courtyard                        |
|          |                                  |   | I3. Fill of foundation trench of wall SU 1434   | 1435                         | 5                            | Southern addition                |
| J        | Floors                           | J1. Crushed tufo preparation                                  | 1455  | 38                           | Courtyard/ Southern addition |                                  |
| Phase 3  | K                                | Construction  | K1. Construction of wall SU 1058  | 1174                         | 170                          | Courtyard                        |
|          |                                  |   | K2. Construction of wall SU 1163  | 1176, 1189                   | 28                           | Rooms 1-2                        |
|          |                                  |   | K3. Construction of wall SU 5146  | 1406                         | 57                           | Southeast sector                 |
|          | L                                | Obliteration/Abandonment                                      | L1. Accumulation along west wall of the courtyard                                     | 1401                         | 55                           | Courtyard                        |
|          |                                  |   | L2. Accumulation of soil in drain 1228 (Fase 1A)                                      | 1221                         | 17                           | Courtyard                        |
|          |                                  |   | L3. Dumps within Room 5   | 1232, 1242                   | 300                          | Room 5                           |
|          |                                  |   | L4. Collapse or dump of building debris in Room 5                                     | 1222                         | 24                           | Room 5                           |
|          |                                  |   | L5. Soil accumulations  | 1158, 1165, 1320, 1327, 1340 | 6336                         | Room 3                           |
|          |                                  |   | L6. Obliteration of walls in Room 4   | 1168, 1218, 1275             | 642                          | Room 4                           |
|          | M                                | Spoliation  | M1. Spoliation of elements of uncertain function (posts?) within Room 3 and courtyard | 1260, 1270, 1271             | 107                          | Room 3, Courtyard                |
| N        | Natural processes                | N1. Colluvial levels in North sector, Courtyard and on Road 4 | 1169, 1177, 1199, 1203, 1388  | 788                          | Rooms 1-2, Courtyard, Road 4 |                                  |
| O        | Activities of uncertain function | Q1. Fill of a cut of undetermined function                    | 1422  | 52                           | Room 6                       |                                  |

**Table 18: Activities associated with Phases and Features in the Tincu House. Discussion of the ceramics refers to these activities.**

In this respect, it is worth emphasizing that the assemblages assigned to Phases 0-1B (5th-2nd c. BCE) contained a significant amount of material whose dating is contemporary with the formation of the deposits, thus providing useful data to reconstruct consumption patterns in the periods when the property was in active use. The assemblages assigned to Phases 2-3 (1st c. BCE-1st c. CE) were much less

informative, despite the fact that they are quantitatively more representative (about 12,000 fragments, corresponding to 70% of the entire sample) because almost all the finds from these levels are in secondary or tertiary deposition, and should be associated with the activities taking place during previous phases of occupation of the site.

The study of the ceramics is based on a general quantification of all the fragments recovered in the excavation of the Tincu house. Because of the high rate of residuality that characterizes the deposits of Phases 2-3, the estimate of the minimum number of individuals (MNI) has been attempted only for the finds from the earlier levels, where the numbers may provide meaningful information. The estimates are derived primarily based on counts of rim fragments. The analysis is based on handles and bases/floors only when these classes of materials could not otherwise be included in the assessment, and fragments of walls have been considered only when assessing pottery classes otherwise unrepresented.

The analysis presented here concentrates on the overall interpretation of the deposits and their absolute chronology, leaving the classification, detailed quantification, and description of individual ceramic classes for future study. As such, it should be considered preliminary.

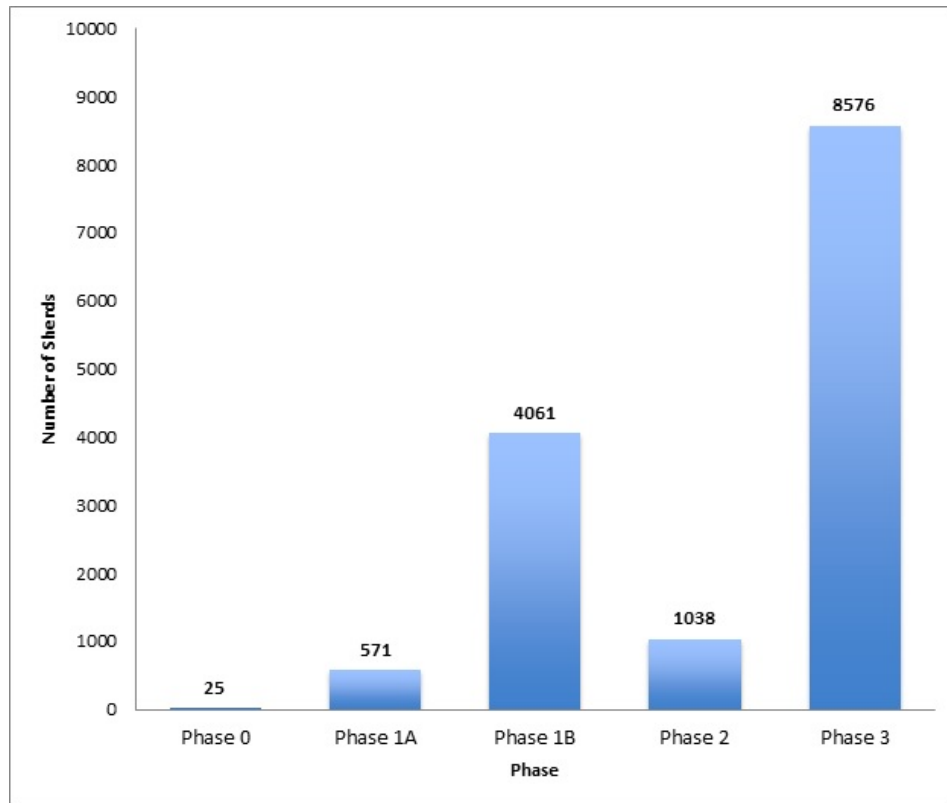
Table 19 details the distribution by phase of the more than 14,000 pottery fragments collected from the stratigraphic excavation of the Tincu house.

Figure 26 and Figure 27 show the distribution by phase of the more than 14,000 pottery fragments collected from the stratigraphic excavation of the Tincu house.

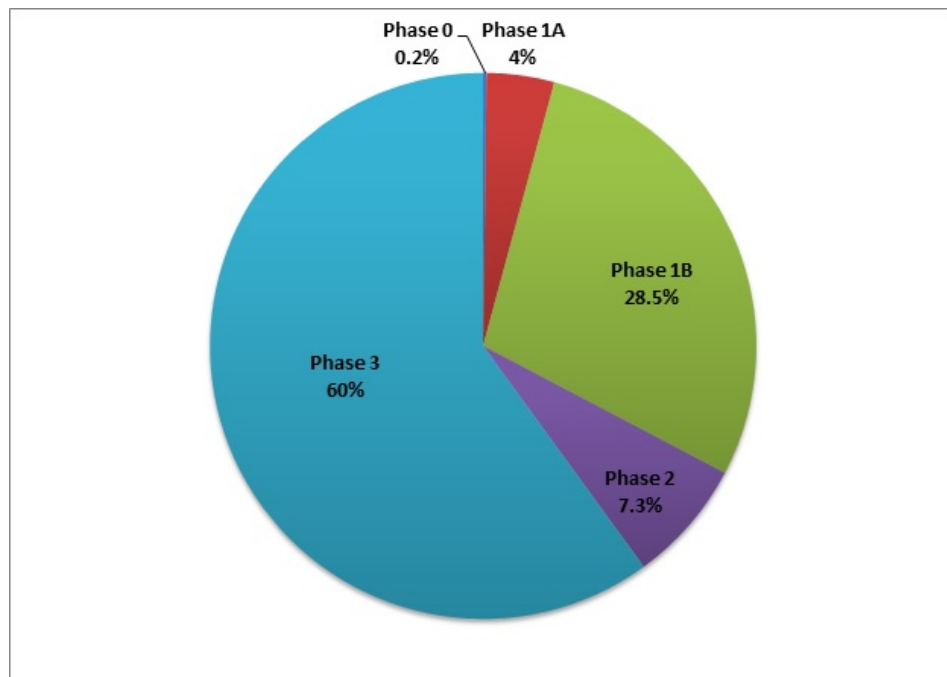
Because a limited number of strata belonging to Phase 0 were revealed and excavated only a very small number of ceramics were recovered, which may be used to characterize and suggest a chronology for this phase. Most features pre-dating the house have, in fact, only been recorded. On the basis of the few ceramic elements retrieved from these SUs (25 fragments, corresponding to a mere 0.2% of the entire sample), it has been possible to define a terminus post quem falling between the 5th and early 4th of the 4th c. BCE (perhaps more precisely between the first half or middle and the end of the fifth c. BCE) for the Phase B-0 activities.

The layers associated with Phase B-1 (and especially Phase 1B) produced a large assemblage of objects (more than 4600 fragments, corresponding to 32.5% of the total sample), which makes it possible to date the main building activities to between the first half of the 3rd c. BCE (Phase 1A) and the late 3rd or early 2nd c. BCE (Phase 1B) with some confidence. This assemblage further reveals a general picture of the kinds of pottery in use in or near the habitation at that time.

The data for Phase B-2 are less robust, due to both the small quantity of sherds recovered from this stratum (1,038 sherds, about 7.30% of the total) and the high levels of residuality of materials originally associated with the stratigraphy of Phases 1A and 1B, which were heavily disturbed during the repurposing of the house in Phase B-2. The few diagnostic elements, combined with the stratigraphic relationships, indicate a date within the second half of the 2nd c. BCE (Phase 2A) and the early or first half of the 1st c. BCE (Phase 2B).



**Figure 26: Ceramics counts per phase.**



**Figure 27: Proportion of ceramics contributed to the total by each phase.**

Residual materials are frequent in the strata belonging to Phase B-3. Despite the large quantity of ceramics retrieved from these levels (more than 8,500 sherds, corresponding to 60% of the total sample), materials contemporary with the possible formation dates of the layers, as limited by the earlier phases of the stratigraphic sequence, are rare. Almost all the pottery from the Phase B-3 deposits are residual and have dates contemporary with the activities of Phases 1 and 2. Though residuality complicates the dating of this phase, ceramics which are likely contemporary with the deposit of the strata are consistent with a terminus post quem of the second quarter of the 1st c. CE for the final abandonment.

### Phase 0 (5th century BCE)

The ceramics belonging to the Phase 0 strata, though few (25 fragments) can be generically associated with the occupation of the area in the period predating the construction of the Tincu house, and provide some insights into the activities occurring at this time. Deposit A1 - containing the ceramics in question - was recovered from one of the few strata excavated below the Phase 1 floors. The strata is a leveling layer, on top of which a tile structure whose function remains uncertain was constructed. This tile structure can be confidently linked with activities taking place in the area. The date of the materials from this deposit ranges between the Early Iron Age and the 5th century BCE (Figure 28).

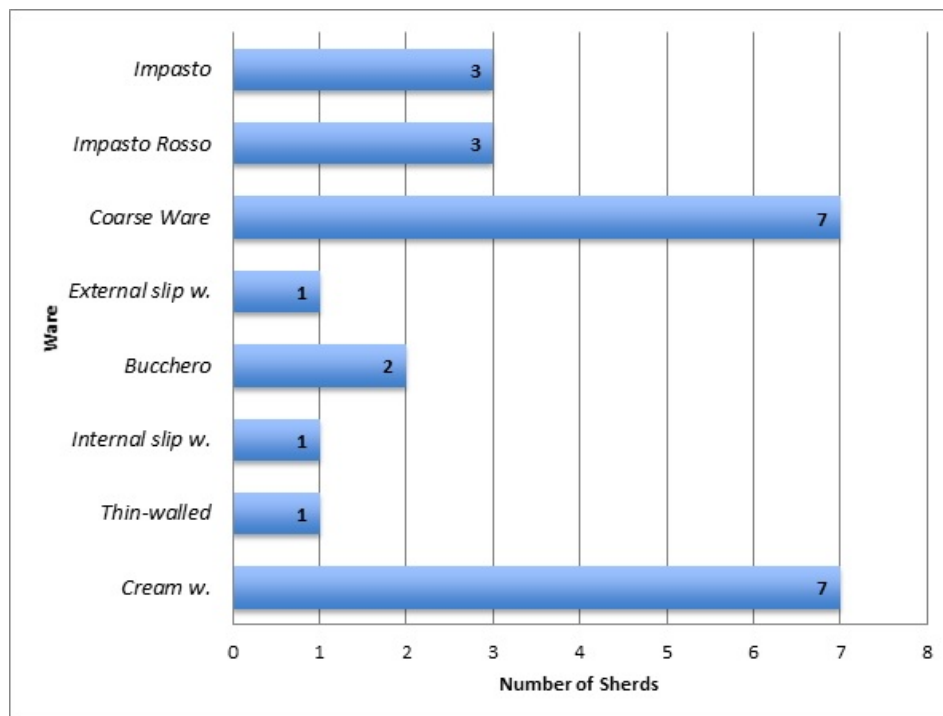


Figure 28: Quantities of sherds per ware for the Phase 0 assemblage.

The sample A1 is dominated by ceramic classes commonly found at sites in Tyrrhenian central Italy between the 6th and 5th centuries BCE. The most common types vessel types are coarsewares used for food preparation. This includes types finished with a slip on either the exterior (External Slip Ware) or the interior (Internal Slip Ware) (Table 20). The occasional presence of graffiti and the complete lack of traces of heat exposure or soot on the exterior of ESW vessels has led scholars to believe that objects of this class were not used for ordinary cooking activities, but rather in sacred activities. A specific ritual function has also been proposed for ISW, at least during its initial phases of diffusion (i.e. assuming that this type of object was introduced into domestic contexts only at a later stage). These hypotheses, however, remain highly debated,[1] and are of little value for the interpretation of the deposit and associated structures found here. Rather, we must consider the possibility that both ESW and ISW are in fact used in domestic food production. Finewares associated with Phase B-0 activities are represented by few fragments of bucchero and cream ware. Based on the stratigraphic position of the SU containing the single fragment of thin-walled pottery recovered, it must be considered an intrusion. Similarly, a small subset of EIA and Orientalizing finds (Impasto and Impasto Rosso) predate the formation of the deposit, and are therefore likely residual.

| <i>Activity</i> | <i>Class</i>       | <i>Production</i> | <i>Shape</i> | <i>Type</i> | <i>Chronology</i>     |
|-----------------|--------------------|-------------------|--------------|-------------|-----------------------|
| A1              | Internal slip ware | Local (?)         | Olla         | non id.     | 500/450 – 250/200 BCE |

**Table 20: Diagnostic elements from Phase 0.**

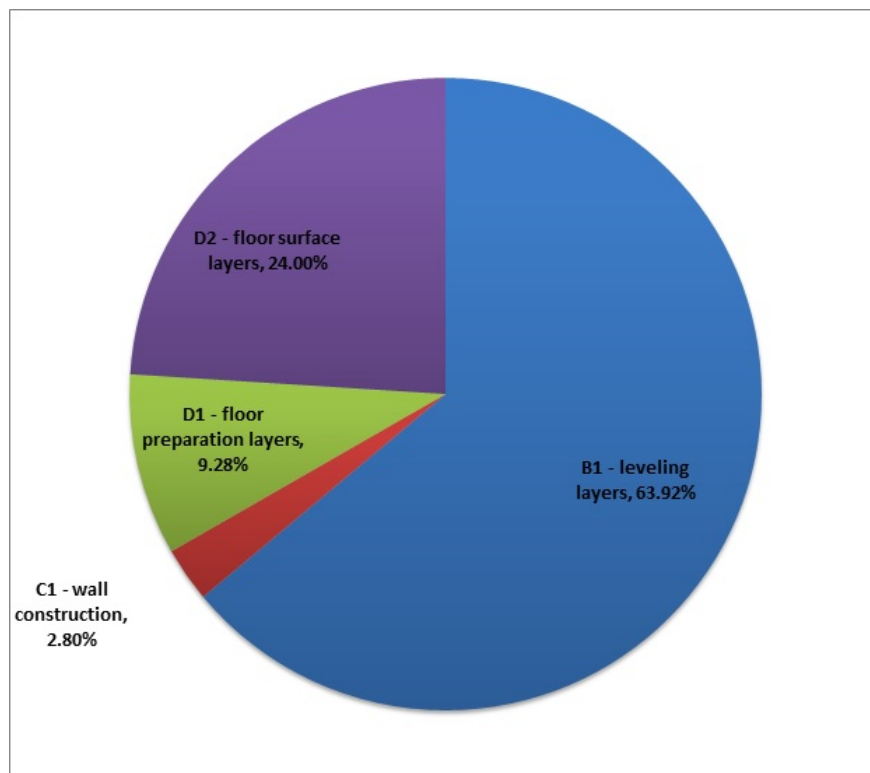
The most diagnostic element used in dating the deposit is a fragment of an ISW olla. There is some disagreement regarding the absolute dating of the production, especially as to when it began. Helga Di Giuseppe has recently re-examined the problem,[2] and has proposed attributing the earliest examples to the second half or late 5th century BCE, confirming the initial chronology suggested by Leslie Murray Threipland on the basis of the finds from Veii.[3] Newly published evidence from Veii,[4] and recent finds from Rome (most notably a late-archaic building brought to light on the Quirinal)[5] seem to indicate a slightly earlier date, between the end of the 6th century and the first half of the 5th century BCE. The preliminary results of ongoing work at S. Omobono,[6] the re-examination of the stratigraphy of the Regia,[7] and the data gathered through current excavations by the Sapienza University of Rome on the north-eastern slopes of the Palatine,[8] all seem to confirm the pattern. At the latter site, finds from the excavation of the Early and Mid-Republican levels of a road leading to the Forum and from two early cult sites facing onto it clearly confirm that the pottery class is present in the urban layers dating from at least the first half/middle of the 5th century BCE. Up to 360-340 BCE, however, examples are quite rare (the class represents approximately 1% of all the coarse wares in contemporary deposits). After this date, the relative frequency of ISW increases progressively, peaking between 280-260 BCE and the mid-3rd century BCE. Based on the available sample, the production of the pottery class seems to decline sharply by the second half of the 3rd century BCE.[9]

The presence of ISW in Deposit A1 suggests that these layers were formed sometime between 500/450 and 280/260 BCE (the terminus ante quem being derived from the chronology of Phase 1A). It should be noted, however, that elements that are otherwise typical in Mid-Republican assemblages in central

Tyrrhenian Italy, such as Early/Mid-Republican Red Slip, Red Figured Pottery, and Black Gloss Pottery with overpainted decoration, to mention only the main ones,[10] are not found in our sample. If not entirely stochastic, this could indicate that the findings from our Phase B-0 predate the appearance of such pottery classes, which we know occurred between the early and mid 4th century BCE.[11] This chronological bracket can be narrowed down further when one considers that the remains assigned to Phase B-0 predate the extensive urban redevelopment linked to the creation of the orthogonal layout of the city. This has been dated independently to the late 5th or early 4th century BCE.[12] It is therefore probable that deposit A1 is earlier than the end of the 5th c. BCE.

### Phase 1A (ca. 280 – 270-265/260 BCE)

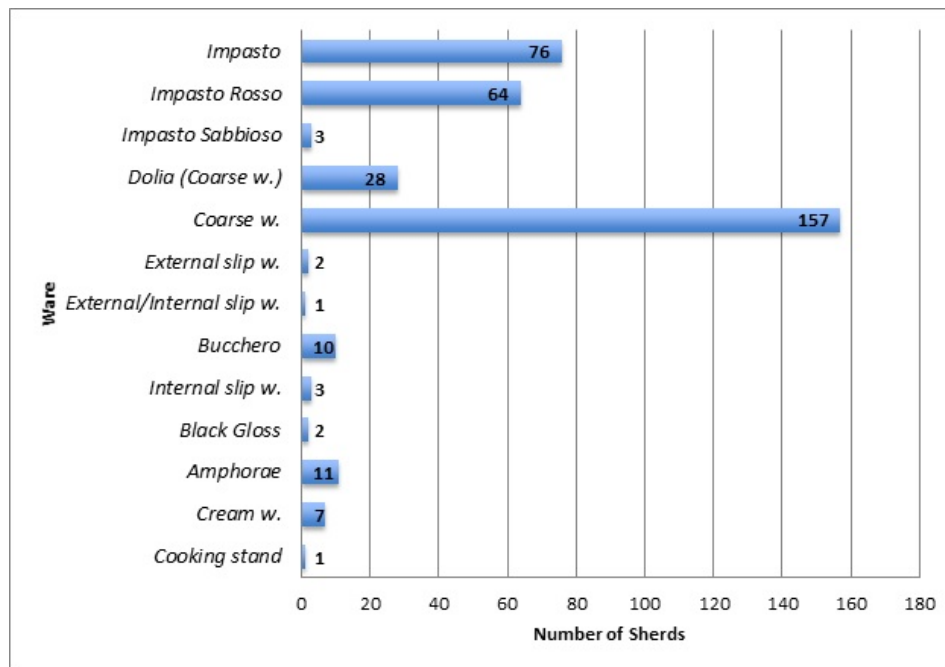
The assemblage associated with the original phase of construction at the Tincu house (Table 21, Figure 29) is made up of 571 pottery fragments recovered from the leveling layers predating the construction of the walls (B). 63.92% of the Phase B-1 assemblage, the majority of the sherds present, were retrieved from these strata. A small subset of the assemblage (2.8% of the sample) comes from construction activities (C), notably the fill of the construction cut for the drainage on the east side of the house (SU 1465), and the fill of the foundation trench for one of the main walls (SU 1440). Finally, another group of objects, corresponding to about 42% of the assemblage, is associated with floor preparations (Activity D1: 9.28%) and finished surfaces (Activity D2: 24%).



**Figure 29: Proportion of the Phase 1 assemblage coming from each activity.**



**Activity B1** – The leveling layers (SU 1205, 1399) predating the house structures have yielded 365 sherds in total (Figure 30). These deposits contain a particularly high percentage of residual sherds, which may be linked with the previous occupation phases of the settlement (Impasto, Impasto Rosso, and a group of Bucchero objects, corresponding to about one third of the entire group). This seems to indicate that earlier deposits were at least partially reworked, most likely in the context of the demolishing of pre-existing structures to make room for the new orthogonal layout in the course of the 5th century. Given the large volume of soil needed to raise the ground level, it is unlikely that the material originated entirely from the Area B site. Rather, it may have been sourced from other neighborhoods of the ancient city.



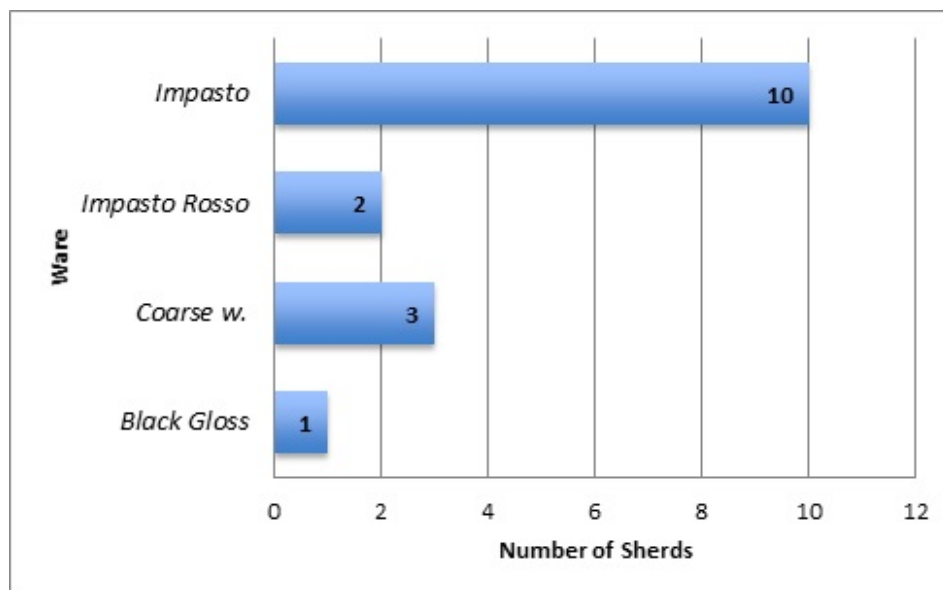
**Figure 30: Quantities of each ware associated with Activity B1.**

Another substantial subset of the sample, roughly equal to one third of the assemblage, consists of cooking wares. The recorded types are not very diagnostic, as the forms in question are in use over a long period. The same is true for the few fragments of large containers (coarse ware dolia), of Impasto Chiaro Sabbioso, of External, External/Internal and of Internal Slip Ware that were recorded.

Only a small proportion of the Bucchero can be associated with the late production of the class (general observations in Rossi 2004; Van Kampen 2004). This late production is found abundantly in Rome and its surroundings until at least the first half of the 4th century BCE (Ferrandes 2015, Facies MR1-2; Ferrandes 2016), after which this category of vessel was definitively replaced by the new finewares of the Mid-Republican period (Black Gloss and other wares with figural decoration). The two lone fragments of Black Gloss Pottery – two walls belonging to open shapes – can be generically assigned, on the basis of their technical features, to types whose production began at the end of the 4th century and continued throughout the 3rd century BCE (on this point see Ferrandes 2008; Ferrandes 2016a).

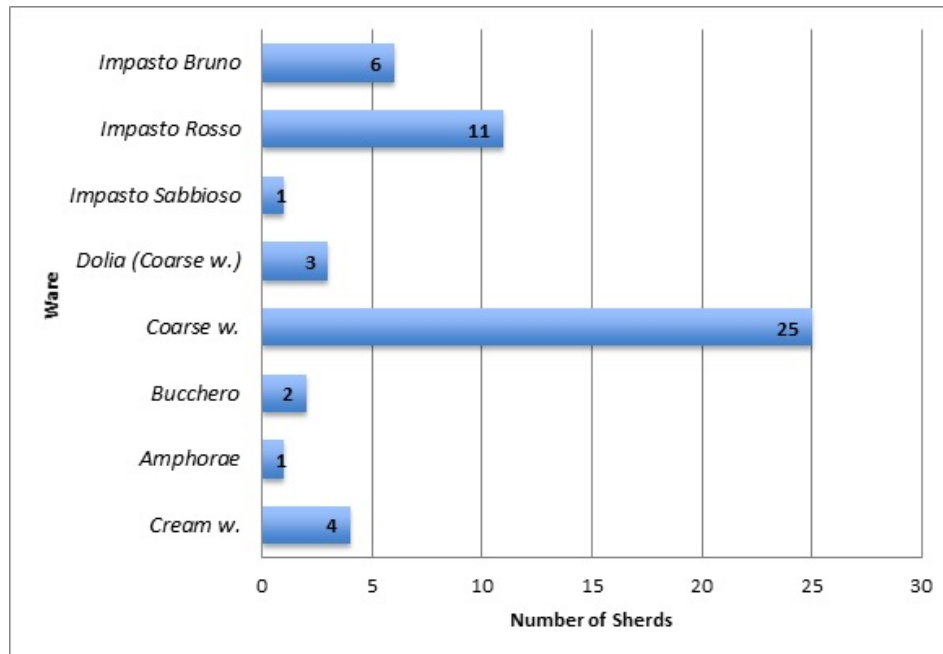
Transport containers are also found associated with this set of activities, but it is not possible to draw any detailed conclusions based on this aspect of the assemblage. The provenance can be suggested on the basis of macroscopic observation of fabric composition to derive generically from the Iberian peninsula, Tyrrhenian coast of the Italian peninsula or Vesuvian area, though the absence of rims, handles and bottoms does not allow us to establish whether these elements are residues or contemporary with the formation of the deposits.

**Activity C1** – The materials originating from the fill (SU 1440) of the foundation trench of the ashlar wall SU 1390 yielded a small number of objects (16 fragments, Figure 31). Almost all of these are very early residuals (impasto pottery and impasto rosso), once again likely derived from the first phase of the occupation of the settlement. One single fragment of black gloss pottery confirms the dating of these strata to the Mid-Republican Era, as suggested by the stratigraphic sequence. The black gloss fragment present comes from a closed shape and may be attributed to the productions at the end of the 4th - 3rd century CE on the basis of its technical characteristics.



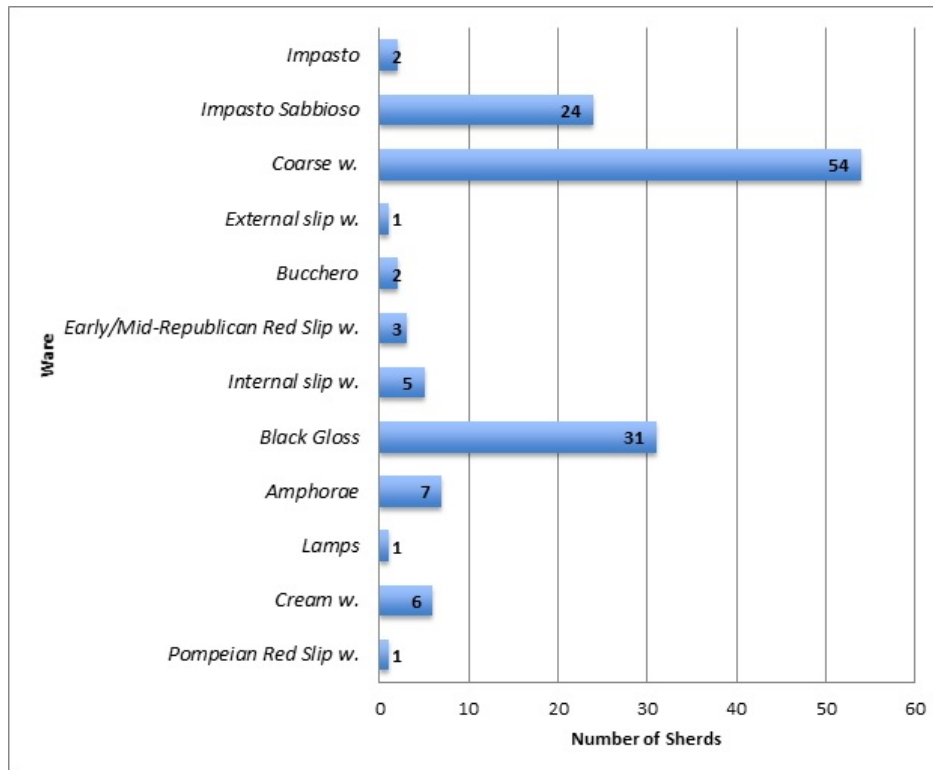
**Figure 31: Quantity of sherds for each ware associated with Activity C1.**

**Activity D1** – SU 1180, a preparation layer for the cocciopesto floor, (SU 1178), found within Room B1, yielded a fair number of sherds - 93 fragments, representing nearly 9% of the sample. These ceramics, however do not add useful information that might allow us to refine the terminus post quem obtained from other contexts assigned to this phase (late 4th century BCE; Figure 32). The deposit mostly contains residual fragments dating to between the Orientalizing and Archaic periods (Impasto Bruno and Impasto Rosso) or wares and shapes that changed little over time (Coarse Ware dolia, Impasto Chiaro Sabbioso). The fragment of a “grey” Bucchero bowl with thickened rim finds comparanda from stratigraphic levels in Rome and neighboring sites dating to between the mid-6th and early 5th c. BCE (Van Kampen 2004). Finally, a fragment of amphora wall with very micaceous fabric could be identified with one of the productions of the Eastern Mediterranean, but it is impossible to determine its precise date.



**Figure 32: Quantity of each ware associated with Activity D1.**

**Activity D2** – The finds from the only portion of finished floor excavated in the courtyard (SU 1173) consist of 137 fragments (Figure 33), approximately one quarter of the entire sample for Phase 1A. Important for distinguishing this assemblage from the ones described above is the relative scarcity of residues, which are represented by just a few fragments of Impasto and Bucchero. While residues are rare, Impasto Chiaro Sabbioso vessels are much more common and coarse ware cooking vessels are also well-represented. Within the assemblage of coarse ware cooking vessels, the proportion of ISW ollae is noticeably greater than that of containers without a slip coating, suggesting that the context should be dated to the period in which, in the region of Rome, this pottery class became more common for the preparation and storage of food (see remarks on Activity A1, above). Unfortunately, rims are absent in this subset of the assemblage, and more detailed studies cannot be pursued.



**Figure 33: Quantities of each ware associated with Activity D2.**

The specimens of Early/Mid-Republican Red Slip Ware present in the assemblage are consistent with a date in the later part of the Mid-Republican period. The only recorded rim belongs to one of the most widespread and long-lasting forms belonging to this category: bowls characterized by a rim with flat lip. This form is found almost exclusively at sites in central Tyrrhenian Italy in contexts dating between the second half of the 5th and the second quarter/middle decades of the 3rd century BCE (Ferrandes 2015; Ferrandes 2016b; Ferrandes forthcoming 1).

A more precise chronological range is provided by the Black-Gloss pottery present. Several rim fragments of hemispherical bowls of the Morel 2783-2784 type, which appear by the end of the 4th c. BCE, and whose production continued for about a century, until the late 3rd or early 2nd c. BCE are present. The same date can be assigned to smaller-sized bowls of the Morel 2787 type, and the bowls with concave-convex profile of the Morel 2621 type. A more refined terminus post quem is given by several floors of bowls of the Morel 2783-2784 type, featuring four stamped palmettes with the same orientation. The palmette type, the profile of the foot and technological aspects of both fabric and gloss have good parallels in contexts from Etruria and Latium dating to the period 280/270-265/260 BCE (Ferrandes 2006, 151-157, Facies 6; Ferrandes 2015 and 2016a, Facies MR7), a phase that has been described as influenced by contemporary productions of Magna Graecia (Morel 1969; Pedroni 2001, 117-129; Stanco 2005, 210; Ferrandes 2006, 153-154; Stanco 2009, 158). A single fragment of Internal Red Slip Ware may be assigned to the same period. This pottery class consists primarily of frying pans whose initial production was originally assigned to the final decades of the 3rd c. BCE (Goudineau 1970). However, recently this class has been re-dated to the first half of the 3rd c. BCE, on the basis of

stratigraphic evidence from Etruria and Latium (for the earliest attestations see Ferrandes 2015, Facies MR 6-7; Ferrandes 2016a; Ferrandes forthcoming 2). In Rome, small frying pans with a dark red slip on the interior surface similar to that used on ISW are found in deposits dating to the first quarter of the 3rd c. BCE (i.e., levelling layers for the construction of the Temple of Victoria on the south-west corner of the Palatine, a site contracted out in 303 BCE and dedicated in 295/4 BCE: Rossi 2004; construction levels on the north slopes of the Palatine, at a site for which Carafa et al. 2014 propose an identification with the Temple of Iuppiter Stator, vowed in 294 BCE; the finds from the latter site are discussed in Ferrandes 2016b and 2016c). Examples from this early stage of their production are relatively rare, becoming more common in the next generation of the production (corresponding to the “Magna-Grecian” phase described above). At this stage, the class is present in most contexts with large pottery assemblages. The diffusion of the class peaks in the middle/third quarter of the 3rd c. BCE (Ferrandes 2015, Facies MR 7-8; Ferrandes 2016b, and 2016c). While it may be understood in the context of a growing production and diffusion, as described above, the example from Gabii is a floor fragment and cannot be securely identified with a specific type.

The only fragment of lamp found in the deposits of Phase 1A seems to belong to the same chronological range. The fragment is very poorly preserved, but it is possible to ascribe it to the so-called “biconico dell’Esquilino” type, whose first appearance in Rome (its likely production center) dates to the “Magna Grecian” phase (a slightly later date is suggested by Pavolini 1987, but see now Borgia 1998 and Ferrandes 2015, Facies MR 7).

A single amphora rim fragment of the “early” Graeco-Italic production (as first identified in Manacorda 1986, and 1989, 443 n.1) can be generically dated from the end of the 4th c. BCE (type Van der Mersch V: see Van der Mersch 1994; 2001). A more detailed typology of the amphora type in question has been recently proposed (Cibecchini and Capelli 2013), distinguishing three sub-types (Va, b and c). Our fragment has points in common with both sub-types Va and Vb. The latter seems to have been introduced only after 280/270 BCE, and to have become especially common in the 260/250-220 BCE period. Unfortunately, however, the preserved portion of the container is not large enough to assign the specimen to the latter sub-type (the inclination of Vb rims does not vary significantly from that of Va rims). It is in any case certain that our fragment does not belong to sub-type Vc, whose diffusion dates from 225/220 BCE onwards, because the profile of Vc rims is much more everted.

A series of final observations can be made on the composition of the ceramic assemblages of Phase 1A and their absolute chronology. First, it is worth noting that the leveling layers and dumps connected with the construction of the house contain a large proportion of residual pottery fragments, mostly dating to the earliest phases of the city formation, i.e. predating the 5th c. BCE restructuring of the urban layout. Thus, we can conclude that building activities in the Mid-Republican period involved the destruction of substantial portions of the pre-existing stratigraphic sequence through the redeposition of many of the early deposits formed within the town. This has important implications for the study of the distribution and character of the pre-5th c. BCE activities at Gabii. While the levelling activities clearly reuse materials from within the town, the floor surfaces themselves appear to be made of more carefully selected materials, as residual ceramics are minimal. The excavated portion of the floor surface

in the courtyard of the house did not yield any pre-5th c. BCE ceramics, and the majority of the finds from this context can be assigned to the Mid-Republican phase.

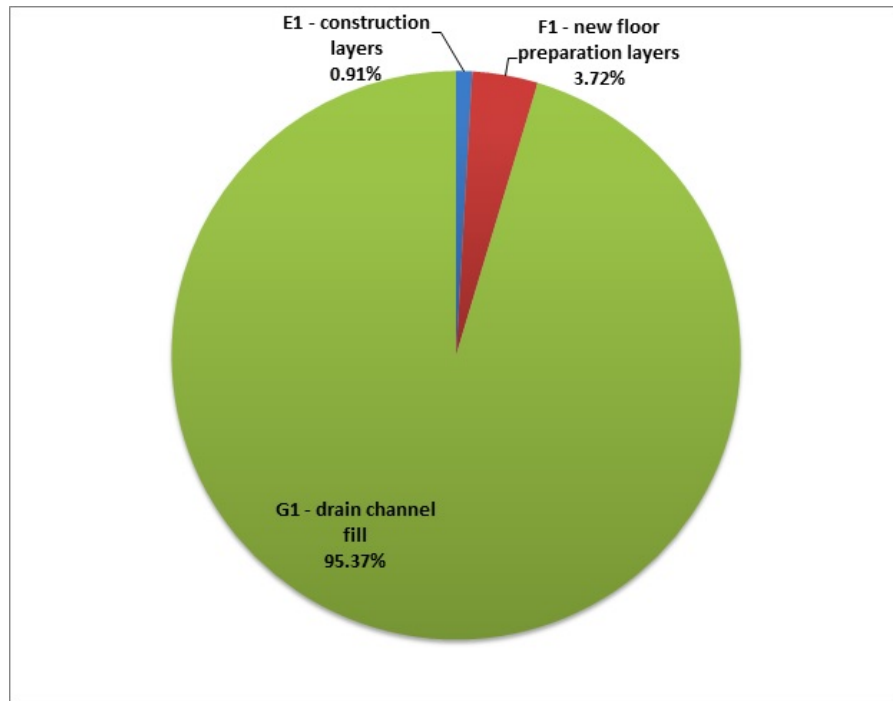
The most diagnostic elements (Table 22) of the assemblage include both finewares (Black Gloss Pottery) and utilitarian wares (Internal Slip Ware; Internal Red Slip Ware), which provide a terminus post quem of 280/270-265/250 BCE for the construction activities. Given the uncertain identification of an amphora fragment (Van der Mersch/Cibecchini Va or Vb sub-type), the possibility of a slightly later date (post 260/250 BCE?) can not be altogether excluded. Based on these elements, the earliest structures of the Tincu house were built in the period between the second quarter of the 3rd c. BCE and the middle of the 3rd c. BCE. For about half a century, the occupation of the house continued without affecting the overall layout, as this was first modified only in the late 3rd or early 2nd c. BCE.

| <i>Act.</i> | <i>Class</i>              | <i>Production</i>             | <i>Shape</i> | <i>Type</i>                                 | <i>Observations</i>                       | <i>Chronology</i>                                     |
|-------------|---------------------------|-------------------------------|--------------|---|---|---|
| D1          | Black Gloss               | Etrusco-latinal/<br>Local (?) | Bowl         | Stamped floor<br>(Morel<br>2783/84?)        | Decoration:<br>Ferrandes 2015,<br>Style C | <i>post</i> 280/270 –<br>265/260 BCE                  |
| D1          | Pompeian Red<br>Slip Ware | Etrusco-latinal               | Pan          | non id.                                     |   | <i>post</i> 300/290 BCE                               |
| D1          | Lamps                     | Etrusco-latinal/<br>roman (?) |              | Biconico<br>dell'Esquilino                  |   | <i>post</i> 280/270 –<br>265/260 BCE                  |
| D1          | Amphorae                  | Tyrrhenian Italy (?)          |              | Cibecchini,<br>Capelli 0000,<br>Va (or Vb?) |   | <i>Post</i> 330/325 (or<br>260/250 – 225/220)<br>BCE? |

**Table 22: Phase 1A: Diagnostic elements.**

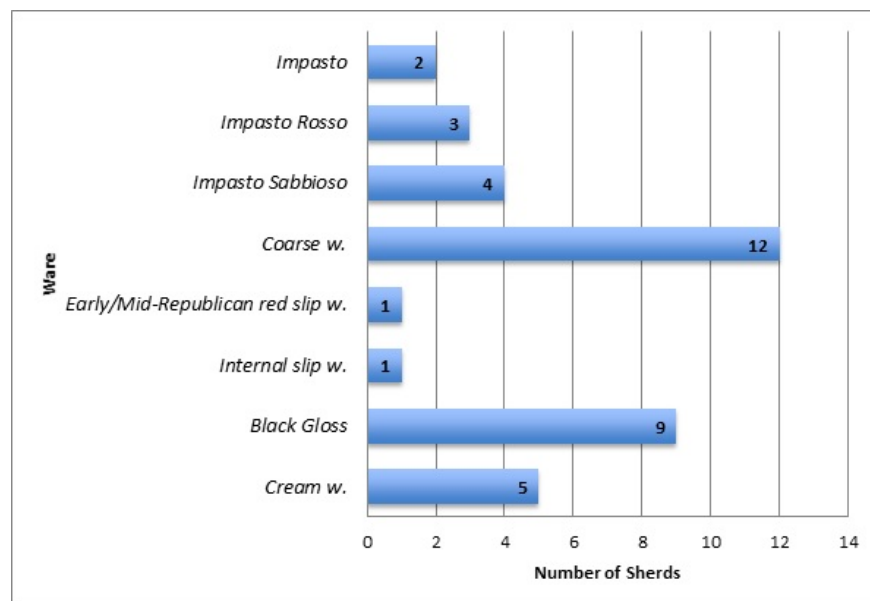
## Phase 1B (late 3rd c. BCE – first quarter of the 2nd c. BCE)

Only a very small proportion of the materials assigned to this phase (Table 23; Figure 34) come from construction levels (E: 0.91%) and new floors preparations (F: 3.72%). Almost all the evidence (95.37% of the entire sample) comes from deposits related to the obliteration (G) of a drain built in Phase 1A ((SU 1322). These layers yielded a significant number of diagnostic elements, which allow us to fix with some confidence a terminus post quem for Activities E1-G1 at the end of the 3rd c. BCE or beginning of the 2nd c. BCE. The precise dating of the stratigraphic contexts of Phase 1B has been facilitated by the availability of well-dated reference assemblages from sites in the Etrusco-Latinal area (Rome, S. Omobono, post-213 BCE: Mercado 1963-63, Ferrandes 2006, 160-161; Lucus Feroniae, post-211 BCE or 196 BCE: Stanco 2005), as well as from shipwrecks (especially the Grand Congloué 1: Benoit 1961; Long 1987).



**Figure 34: Proportion of the sherds from each activity in Phase 1B.**

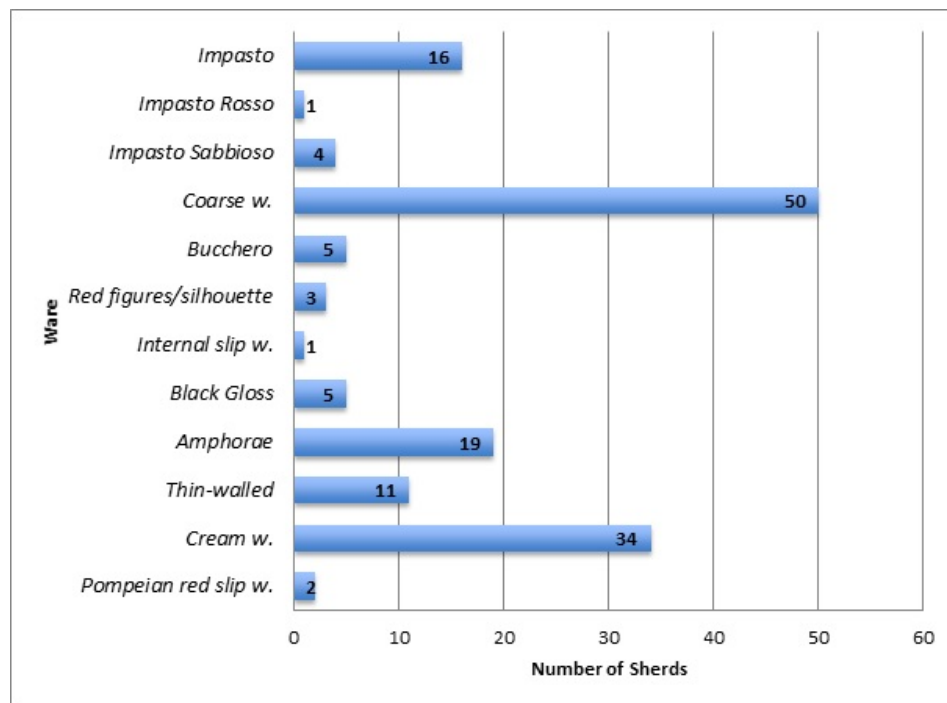
**Activity E1**—The stratigraphic levels connected with the construction of the southern addition (SU (1424 and SU (1446) contained very few ceramics (37 sherds, corresponding to about 1% of the overall Phase 1B sample). With the exception of a small number dating to the EIA and Archaic periods (Impasto and Impasto Rosso pottery), the finds can be assigned to the Early and Mid-Republican period (Figure 35).



**Figure 35: Quantification of the wares associated with Activity E1.**

In addition to the ubiquitous hemispherical bowls of the Morel 2783-84 type, the Black Gloss pottery present includes less common types, like the small bowl with continuous profile and groove at the foot (Morel 2753). The latest element in the assemblage is a plate/patera with oblique wall and groove at the lip (Morel 2823). Notably, this type is never found in the deposits dating the first half or middle of the 3rd c. BCE (Phase 1A). Rather, it is systematically associated with Phase 1B contexts (see Activity G1). The distribution of this shape at Etrusco-Latial sites dating to the late 3rd and early 2nd c. BCE (e.g., at Lucus Feroniae: Stanco 2005, 214) provides a reliable terminus post quem for the entire assemblage.

**Activity F1**– The deposits associated with the new floor preparations produced a relatively small number of ceramics (151 sherds, Figure 36), among which there are several diagnostic elements. Residues include both pre-5th c. BCE classes (Impasto, Impasto Rosso and Bucchero) and Early/Mid-Republican wares (e.g., Genucilia plates, coarse ware and ISW). However, most of the finds seem to date to the Late Republican period, to which we assign this activity.



**Figure 36: Quantification of wares associated with Activity F1.**

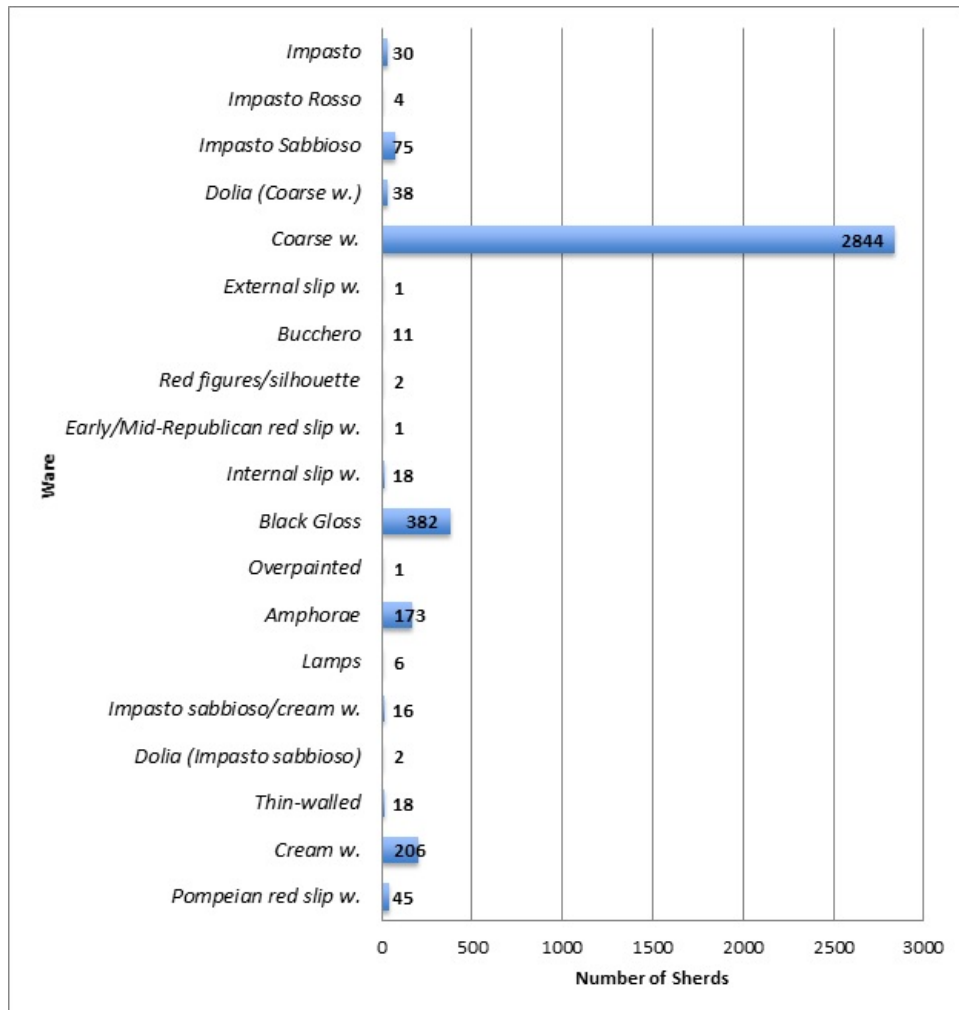
The sample of Black Gloss pottery associated with this activity consists of fragments of walls, with the exception of one handle, so it is not possible to identify specific morphological types. While lacking the usual diagnostic elements, the technological aspects of these materials demonstrate a clear difference with the Mid-Republican productions: the latter are characterized by shiny gloss and an extremely fine fabric fracturing with clean break lines, while the former feature a coarser fabric producing irregular fractures and opaque gloss.



A more precise chronological indicator is a Thin-Walled beaker of the type Marabini I, whose earliest examples in central Italy date to ca. 200 BCE (Ferrandes 2015, Facies MR 10; Ferrandes 2016a). Another production that first appears in the Phase 1B contexts of the Tincu House is a Cream Ware one-handled goblet with an everted rim and slip on the upper part of the body, which is common in the Gabii area in the late 3rd c. and early 2nd c. BCE (e.g., Città dello Sport; Ponte di Nona: Bertoldi 2011, 85-86, Olla type 2).

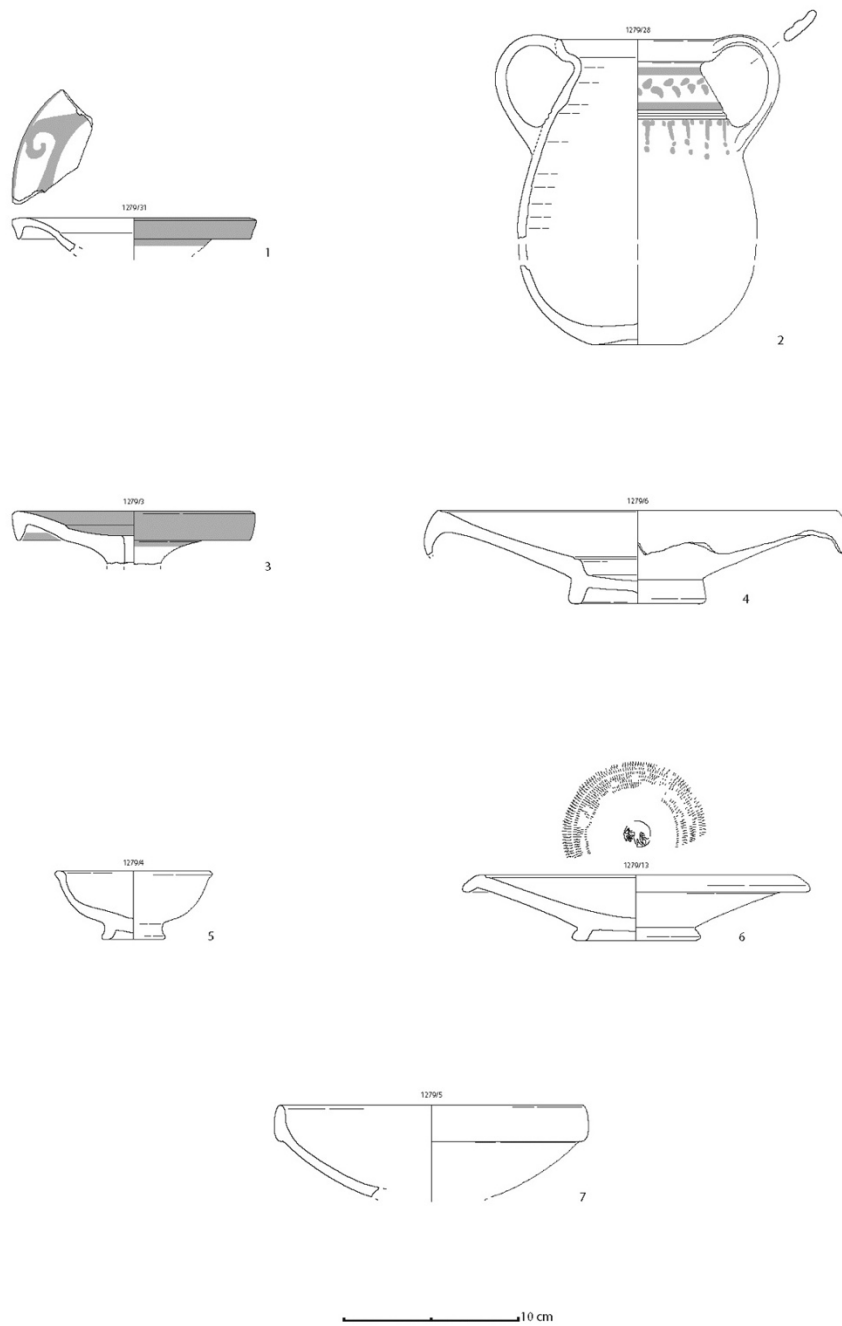
The amphora sample includes fragments that can be generically attributed to Eastern Mediterranean, North African, Tyrrhenian and perhaps Iberian productions. The Tyrrhenian amphorae, which are probably all from the Campanian region, include fragments of the “late” Graeco-Italic type Van der Mersch/Cibecchini VIb, dating to the first quarter of the 2nd c. BCE (Cibecchini and Capelli 2013, 443).

**Activity G1**– With its 3.873 fragments (Figure 37), the fill that obliterates one of the main drains of the Phase B-1 house represents the richest deposit not only from our site (the finds correspond to about 27% of the total number of sherds collected from the Tincu House), but also from contemporary sites in the broader region of Rome. Our assemblage is outstanding not only in terms of quantity and quality, but also for the state of preservation (several individuals have been fully or almost fully reconstructed). This suggests that the items deposited in the drain may have been part of the pottery set in use in the house itself, not secondary refuse. It is possible that the discard of the materials happened immediately before the restructuring of the house in Phase B-2. That this was the result of a single action and not of a series of dumps over a longer period of time is indicated by the fact that most elements can be dated to the same chronological range. Residual pottery is negligible, representing less than 5% of the assemblage. We can mention fragments of Early Iron Age impasto pottery of the, and fragments of Impasto Bruno, Impasto Rosso and Bucchero, dating between the 7th c. and 5th c. BCE. Among the cooking vessels are a few sherds of Coarse Ware and Internal Slip Ware, dating between the late Archaic and the Mid-Republican periods.



**Figure 37: Quantification of wares associated with Activity G1.**

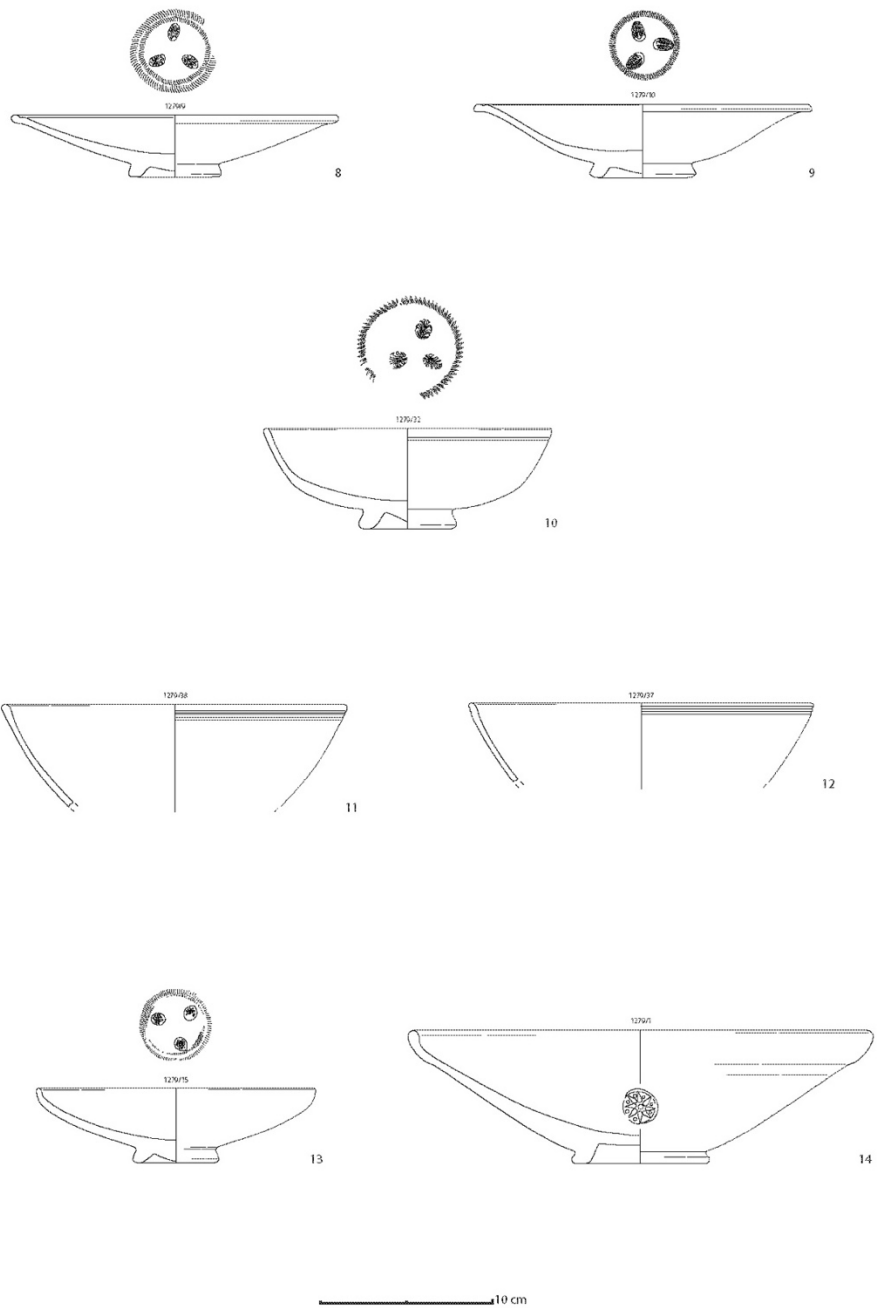
Among the materials dating from the Mid-Republican period onwards, two fragments can be assigned to the class of the Genucilia Plates (Figure 38, fig. 1), a red figured pottery produced in central Italy (Ferrandes 2016a). The state of preservation does not allow us to identify whether the motif in the central tondo was that of a female head or a geometric one. There is just one specimen of overpainted Black-Gloss pottery, a jug decorated with vegetation motifs of the so-called Gnathia style (Figure 38, fig. 2), which is another class produced by workshops of central Tyrrhenian Italy from the end of the 4th c. BCE onwards until 260-240 BCE (Ferrandes 2006, 157-160; Ferrandes 2016a). The object is fully preserved, and can be compared with Morel form 3682 (though shoulder and rim are quite different from the published examples). The object in question might be interpreted as a heirloom, unless we admit that the production of this ware continued for a longer period than commonly thought.



**Figure 38: Tincu House, Phase B-1 B. Illustrations of key diagnostic elements from the east drainage fill assemblage (Activity G1; SU 1279): Genucilia plates (n. 1), Gnathia ware (n. 2) and Black Gloss pottery (n. 3-7).**

Besides these sporadic attestations of figured ceramics, the most frequent fineware class is Black-Gloss, which with 382 fragments (corresponding to 10% of the sample from Phase 1B) represents the almost totality of the subset. The vessel shapes attested in the assemblage are almost exclusively open forms dating to between the end of the 4th and the first half of the 2nd c. BCE. Types appearing in the late 4th c. BCE include plates with outcurving rim thickened on the outside (Morel 1111; Plate 1, fig. 3), rare fish plates Morel 1124 (Plate 1, fig. 4), and a bowl with concave and convex profile (Morel 2621; Plate 1, fig. 5). Of a slightly later date (i.e., 280/270 – 265/260 BCE) is bowl decorated with 4 stamped rosettes on the bottom. The rosettes are of a type which is characteristic of the phase in which the Etrusco-Latial productions were heavily influenced by contemporary styles from Magna Graecia (Ferrandes 2015, Facies MR 7). Bowls with as single stamp (mostly rosette), which are more frequent in the assemblage date to the next phase of the Petites Estampilles production Ferrandes 2015, Facies MR 8, mid-3rd c. BCE). Examples of Heraklesschalen characterized by a stamped figural motif surrounded by a rouletted band, in at least one case associated with a plate/patera Morel 1534 (Plate 1, fig. 6), can be assigned to the late 3rd c. BCE (Ferrandes 2015, Facies MR 9, 240-210 BCE). Although commonly dated to the first half of the 2nd c. BCE, several examples of hemispherical bowls of the Morel 2534 (Plate 1, fig. 7) type should be attributed to a slightly earlier period, the late 3rd or early 2nd c. BCE, due to the presence of the single central stamp (indeed the Latial production of Black Gloss pottery featuring stamped decoration terminates at the end of the 3rd c. BCE).

Another subset of Black-Gloss pottery has been identified based on both technological features (quality of the gloss; fabric) and type of decoration (impressed and rouletted). This is represented by plates/patera with everted rim and groove near the lip (form Morel 1281; Figure 39, fig. 8-9), and deep bowls decorated with grooves on the exterior of the rim (forms Morel 2572: Figure 39, fig. 10; and 2573: Figure 39, figs. 11-12). Both the Morel 1281 and the Morel 2572 attested in the sample are decorated on the interior with 3 stamps, featuring a palmette motif surrounded by rouletted bands. While the dimensions of the stamps vary, the compositional style is very uniform. The palmettes are extremely stylized, with the leaves represented with simple oblique lines branching off from a thicker central element (Stanco 2005, 210). Perhaps slightly later in date are examples of the larger plate/patera Morel 2821-2823 (Figure 39, fig. 13; cf. Activity E1), which are characterized by the same kind of decoration (Figure 39, fig. 14). These standardized features suggest that the vessels were produced by the same workshop, whose identification remain uncertain. A group of objects very similar in terms of shape range and decoration, however, has been documented at the sanctuary site of Lucus Feroniae, and tentatively attributed to Faliscan workshops active in the second half of the 3rd c. BCE (Stanco 2005, 210-217).

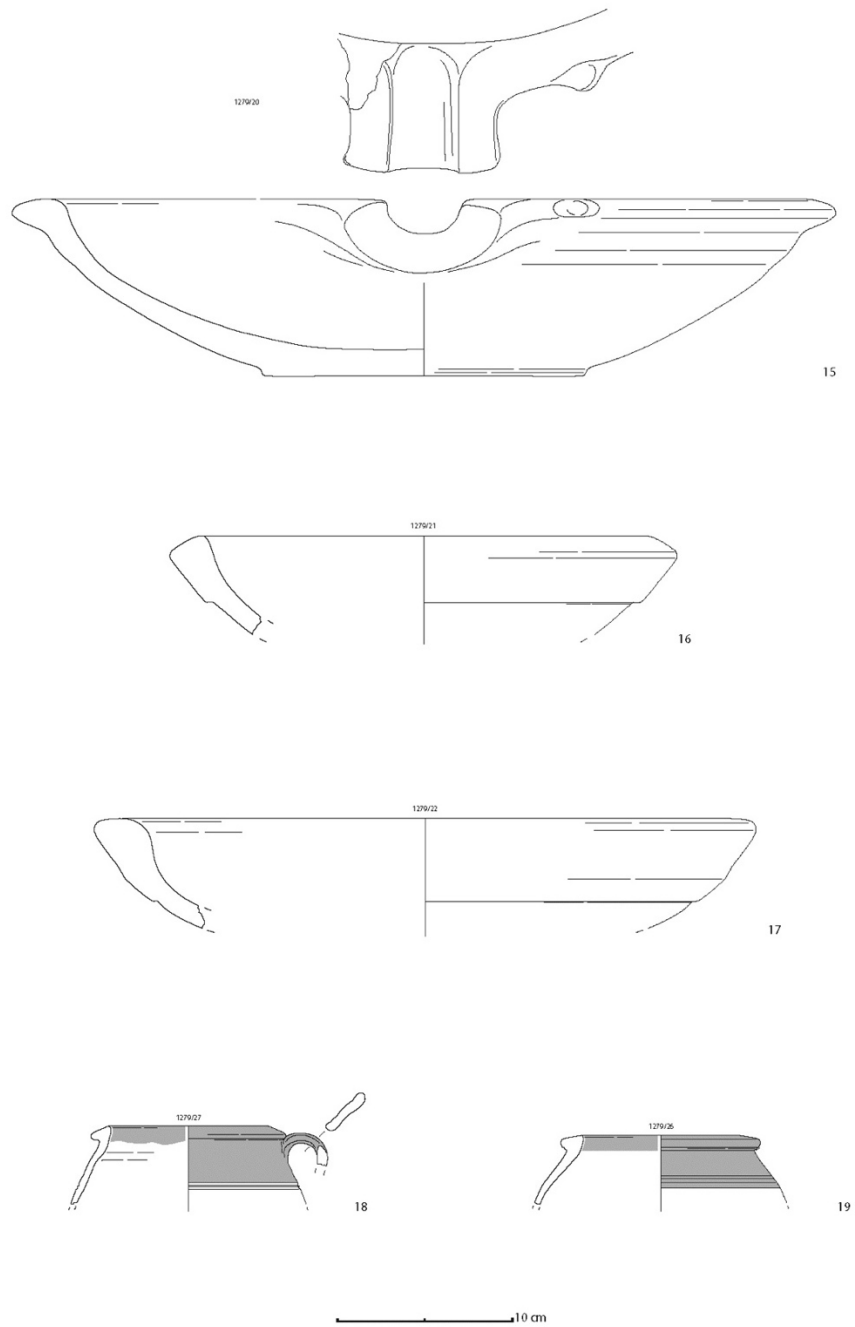


**Figure 39: Tincu House, Phase B-1 B. Illustrations of key diagnostic elements from the east drainage fill assemblage (Activity G1; SU 1279): Black Gloss pottery (n. 8-14)**

Lamps are rare in this assemblage. Three fragments of the Black Gloss type were identified. The shapes of these vessels find comparanda with Roman examples, of which the earliest examples are dated stratigraphically to the late 3rd and early 2nd c. BCE, such as the Tevere 2a biconical type with vertical rim (Borgia 1998).

To conclude our discussion of the finewares, it is worth noting the occasional presence of fragments of Thin-Walled beakers of the Marabini I type (cf. Activity F1), which is documented in stratigraphic deposits at other sites of central Italy from the late 3rd c. BCE, though only sporadically. The type becomes more common in the first half of the 2nd c. BCE.

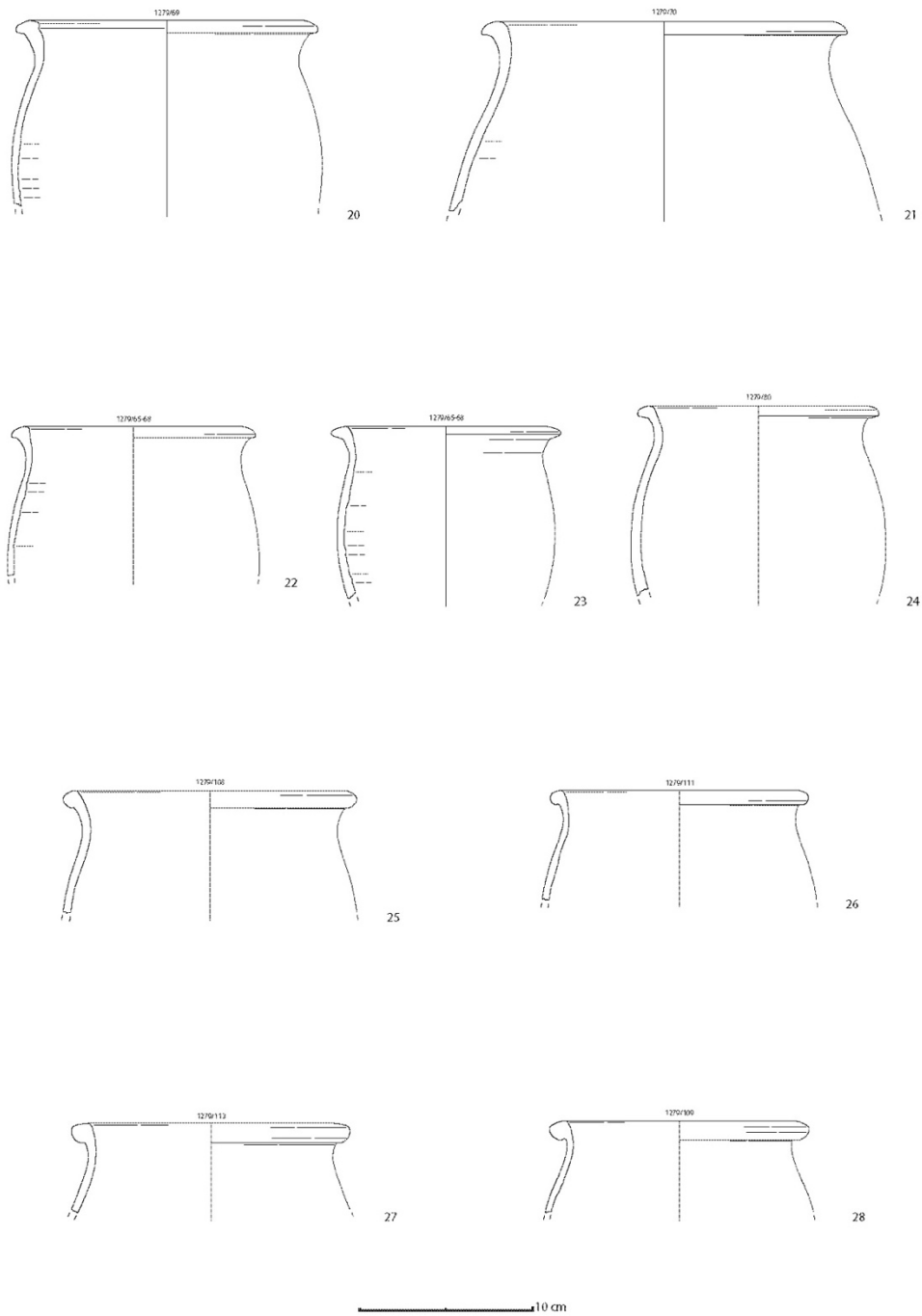
Common wares for the preparation, consumption and storage of food, represent approximately 6% of the drainage fill deposit, and can be dated generically to the second half of the 3rd c. and the 2nd c. BCE. This group of vessels includes a spouted mortarium (Figure 40, fig. 15), whose shape recalls earlier examples of the Impasto Chiaro Sabbioso production (Figure 40, figs. 16-17), from which it differs in that there is significantly less augite in the fabric. Furthermore, there are at least two examples of the (one-?) handled olla with an outcurving rim and slip on the upper body (Figure 40, figs. 18-19), of the type also found in Activity F1 at Gabii.



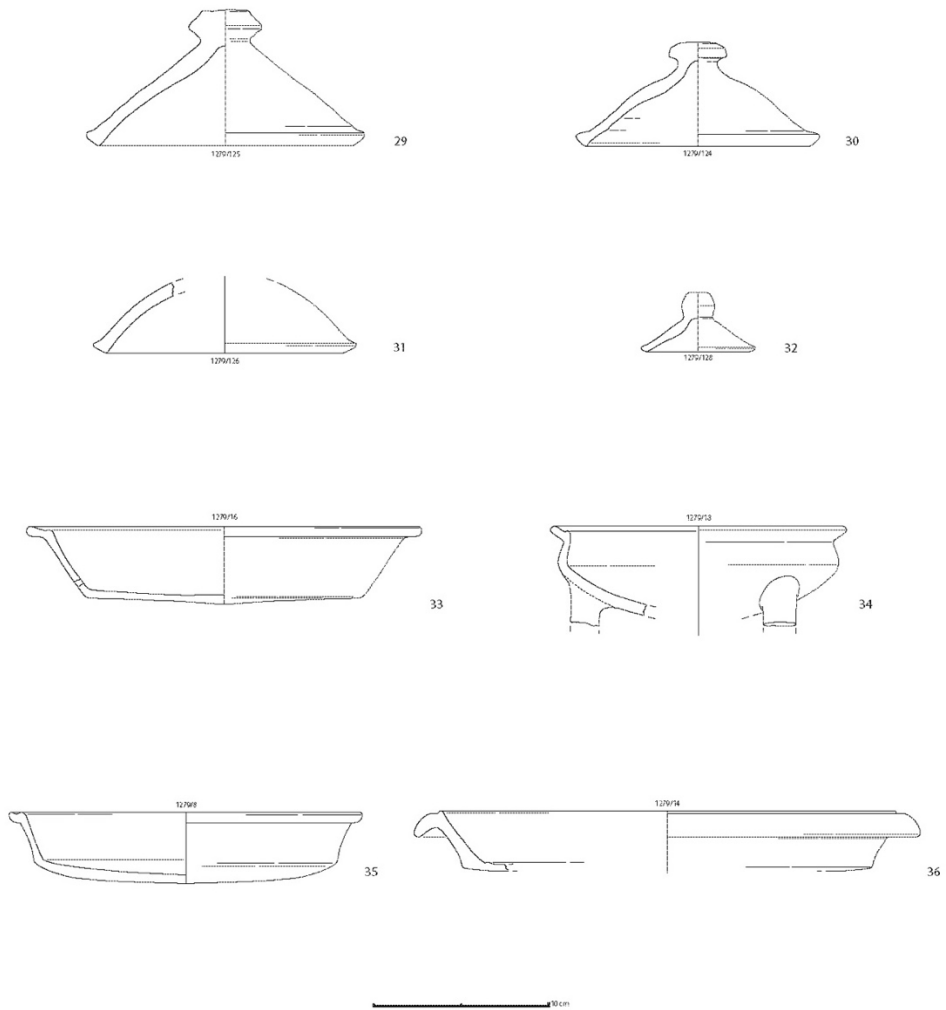
**Figure 40: Tincu House, Phase B-1 B. Illustrations of key diagnostic elements from the east drainage fill assemblage (Activity G1; SU 1279): Impasto Chiaro Sabbioso mortaria (n. 15-17) and one-handed Cream Ware ollae/goblets (n. 18-19).**

Most fragments, however, belong to cooking vessels (almost 3000 sherds, corresponding to 73% of the entire sample), whose comparanda date to the 2nd c. BCE. The most common shape is the olla, particularly the type with an outcurving and slightly pointed rim (Bertoldi 2011, 94-95, Type 4; Figure 42, figs. 20-24). Less commonly found are specimens with small thickened rims, especially the variant with a rounded lip (Bertoldi 2011, Type 1). Both types are documented elsewhere at Gabii (Temple of Juno: Vegas and Martin Lopez 1982, 453 fig. 1.7), in the east suburbium of Rome (Città dello Sport, Ponte di Nona and Torre Spaccata: Bertoldi 2011, 91 and 94-95), and at the urban site of Tusculum (Dupré et alii 2000, p. 34, fig. 26.14), again in deposits that have been dated to between the 3rd c. and the 2nd c. BCE. Important for understanding the character and chronology of the assemblage is the complete absence of ovoid ollae of the type known as "orlo a mandorla," which are ubiquitously found in contexts dating from the middle of the 2nd c. BCE onwards (Bertoldi 2011, 95-97 Type 5). Lids are less numerous than the ollae; the types present can be dated to between the second half of the 3rd c. and the early 2nd c. BCE (Figure 42, figs. 29-32).. The form identified most frequently other than the ollae and lids is the pan, of which there are examples in both Coarse Ware and Internal Red Slip (Figure 42, figs. 33-36). The variants find comparanda with types common during the period of transition from the Mid- to Late-Republican periods (Ferrandes forthcoming 2). Finally, there are several examples of portable ovens (clibanus), which have been documented at nearby sites (e.g. Ponte di Nona) in 2nd c. BCE deposits (Bertoldi 2011, 108-109).



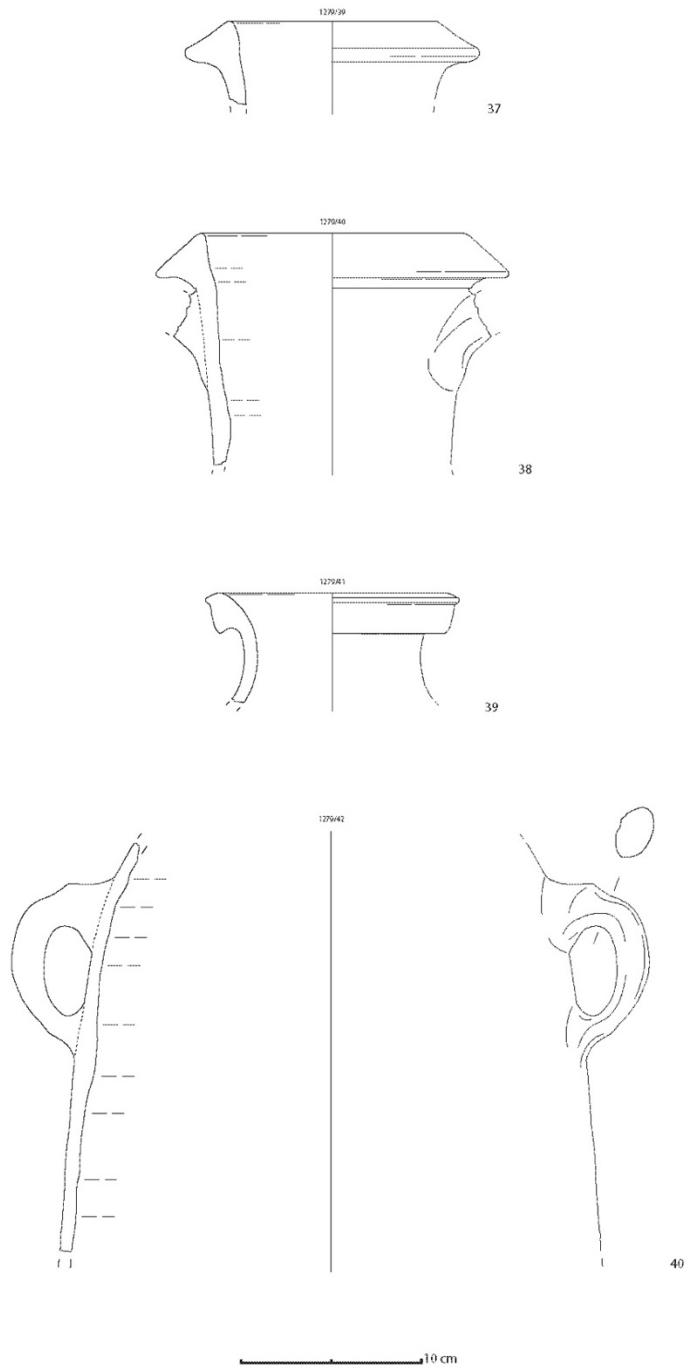


**Figure 41: Tincu House, Phase B-1 B. Illustrations of key diagnostic elements from the east drainage fill assemblage (Activity G1; SU 1279): Internal Slip Ware ollae (n. 20-28).**



**Figure 42: Tincu House, Phase B-1 B. Illustrations of key diagnostic elements from the east drainage fill assemblage (Activity G1; SU 1279): Coarse Ware lids (n. 29-32), Coarse Ware and Pompeian Red Slip pans (n. 33, 35-36), and Coarse Ware cooking stand (n. 34).**

Amphorae appear infrequently in the deposits from this phase. The assemblage includes at least two examples of the “early” Greco-Italic type van der Mersch Va (330/325-275/260 BCE) or Vb (260/250-220 BCE), whose fabric suggests a Campanian origin. Another fragment, possibly from the same production area A, can be attributed to either the Van der Mersch/Cibecchini type Vc (last quarter of the 3rd c. BCE) or VIa (210-190 BCE: Cibecchini and Capelli 2013, 434-443). A single example of a North African amphora of the type van der Weff 3 (Figure 43, fig. 39), which dates to between the late 3rd or early 2nd c. BCE, is present. Fragments of at least one other Late Punic container have been identified (Figure 43, fig. 40), as well as walls of Eastern Mediterranean amphorae.



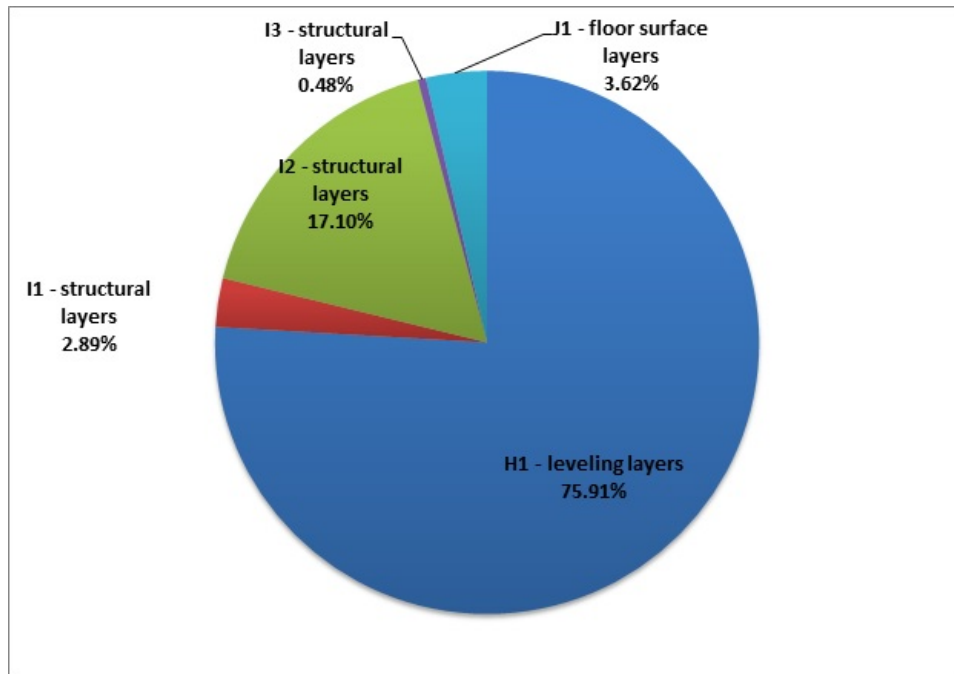
**Figure 43: Tincu House, Phase B-1 B. Illustrations of key diagnostic elements from the east drainage fill assemblage (Activity G1; SU 1279): Amphorae (n. 37-40).**

To summarize, there are numerous diagnostic finds that allow us to date the activities of Phase 1B (Table 7) with confidence. The Black Gloss pottery sample includes types that were introduced in Etruria and Latium during the transition from the Middle to the Late Republican period. The examples of the patera Morel 1281 form and bowls of the Morel 2572-73 forms seem to originate from a single production center, as they share similar fabric, gloss and decorations. Further analyses are required to confirm the possible connection with Lucus Feroniae. While these productions have a limited diffusion in central Tyrrhenian Italy, the plate/patera of the Morel 2821-23 form is widely distributed in 2nd c. BCE contexts. Another significant aspect of the character of the assemblage is the presence of Thin-Walled Pottery. Most notably the earliest beaker type, Marabini I, provides a terminus post quem of 200 BCE. The same horizon is suggested by the "late" Graeco-Italic amphorae Van der Mersch/Cibecchini VIa, the North African van der Weff 3 (both dating from the end of the 3rd c. BCE onwards), and the slightly later Van der Mersch/Cibecchini VIb (first quarter of the 2nd c. BCE). Finally, a fixed point in the late 3rd c. BCE has been proposed for some of the common wares for food storage and consumption (the olla/beaker Bertoldi 2) and for two cooking vessels (olla Bertoldi 1 and 4). Beyond changes in the morphology of the vessels, there are interesting technological innovations, which indicate a complete departure from the pottery traditions established in the Archaic period.

To conclude, it is possible to date the construction activities of Phase 1B between the late 3rd c. or early 2nd c. BCE and the late 2nd or early 1st c. BCE (i.e., the terminus ante quem provided by the materials recovered from the stratigraphy of Phase B-2). The absence of finds common in central Italy during the second quarter/middle of the 2nd c. BCE is a strong indication that these activities occurred during the first quarter of the 2nd c. BCE, a period which corresponds well with date of the latest elements of the assemblage.

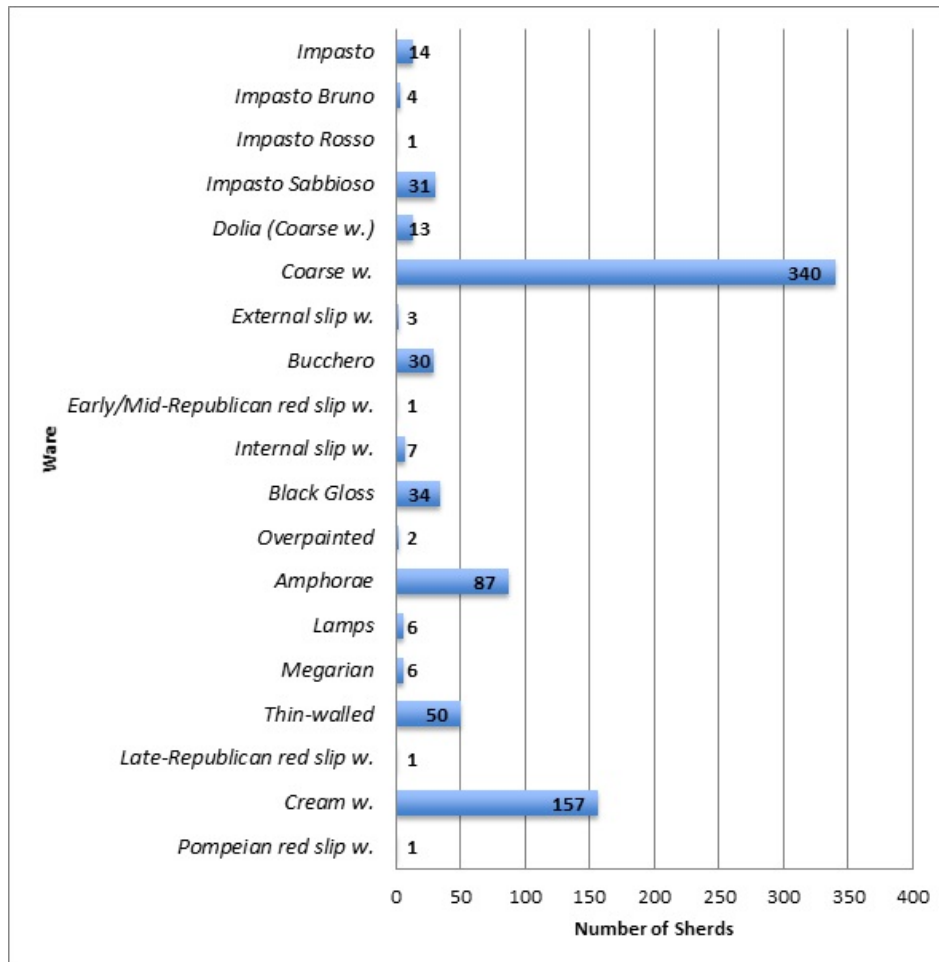
## **Phase 2 (late 2nd/early 1st c. BCE)**

The strata associated with Phase B-2 yielded 1038 fragments (Table 24, Figure 44), corresponding to about 7% of the entire sample from the Tincu House. The construction activities occurring during this phase have been interpreted as the result of a significant change in the function of the building, from a domestic to a utilitarian structure. The majority of the material for this phase derives from the leveling layers that raise the floors (Activity H: 75.91%). A smaller yet still significant group of objects belong to construction features (Activity I: 20.47%), while few ceramics come from the layers used for finishing floor surfaces (Activity J: 3.62%).



**Figure 44: Proportion of sherds coming from each activity associated with Phase 2.**

**Activity H1**– Leveling layers that have been excavated in Room B6 (SUs 1386, 1443, 1457) contained 788 sherds (Figure 45), many of which are residual. These residual finds range from the earliest phases of occupation of the settlement, the EIA to Late Archaic periods (Impasto, Impasto Bruno, Impasto Rosso, Impasto Chiaro Sabbioso, Bucchero, coarse ware dolia, ESW and ISW), to the Mid-Republican phase (Early/Mid-Republican Red Slip, Black Gloss including the overpainted types, Coarse Ware and Cream Ware). Several diagnostic elements, however, allow us to date the building activities with some precision.



**Figure 45: Quantification of the wares associated with Activity H1.**

Black Gloss pottery is again the most common fineware in the assemblage. Other than a few fragments dating to the Mid-Republican Period, which can be interpreted as obvious residues from Phase 1A-B, the diagnostic fragments suggest that the context dates to after the middle of the 2nd c. BCE. Frequent finds of pateras with everted rims (series Morel 2252-58), plates with the same profile (Morel 2283, 2286) and fragments of large plates with undulating rims (Morel 1440) characterize the assemblage. This last type may be slightly later in date (last quarter of the 2nd c. BCE).

Within these deposits a fragment of Late-Republican Slip Ware was recovered. Recently, this class has been identified in stratigraphic contexts from Rome dating to between the late 2nd c. BCE (e.g., at the north-east slopes of the Palatine: Ferrandes 2014a, 187 n. 94) and the middle of the 1st c. BCE (e.g., the fill of a Pozzolana quarry at the site later occupied by the Horti Lamiani on the Esquiline: Ferrandes 2014b, 360-361). This seems to be one of the many local red gloss productions that predate Italian sigillata. The class is characterized by an extremely fine micaceous fabric and a slip ranging in color from orange to coral red with soapy consistency (much like the contemporary Dressel 2 and 3 lamps and of the Black Gloss productions with grey fabric, also known as Roman D, both manufactured in Rome).

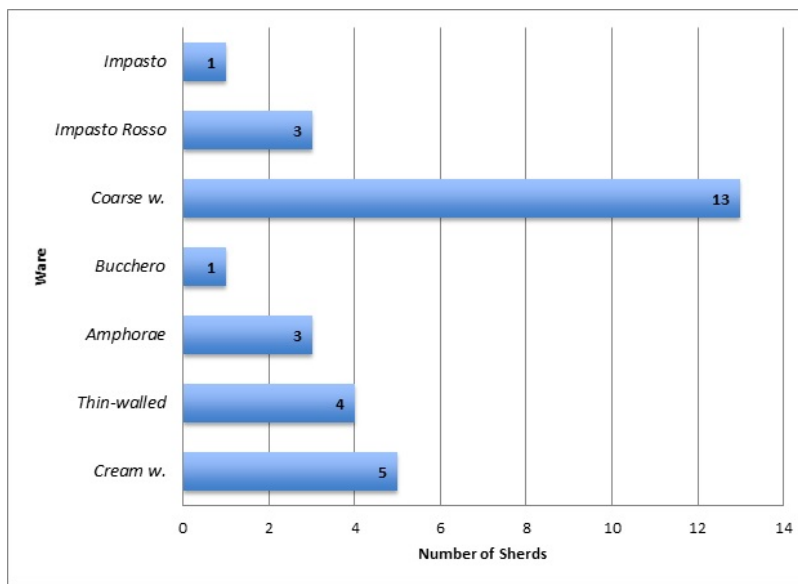
While the morphological repertoire is still poorly known, both closed and open shapes have been documented. The Gabii example is an open form.

Fragments of Megarian bowls and Thin-Walled pottery are datable to the 2nd c. BCE generically, and so are not helpful for refining the chronology. One exception to this is the ovoid beaker Ricci I/7 (Marabini III) found in the deposits, which dates to after 150 BCE (Ricci 1985, 245). A more precise terminus post quem is provided by the Cream Ware lamp type Ricci H (usually dated from the late 2nd c. BCE onwards at Delos, and somewhat later in Rome, especially from the Sullan phase onwards: Ricci 1973, 223-226).

About two-thirds of the sample is made up of common wares, including types whose presence has been noted in Phase 1B. These date generically to the 2nd c. BCE, and it is uncertain whether they are residues or types in circulation for a long period. Among the cooking wares the “orlo a mandorla” olla (Bertoldi 2011, 95-97, Type 5), which appears in the Late Republican period and becomes widespread in Etruria and Latium, contributes to establishing the chronology.

A date of 150 BCE or later is provided by rare fragments of Dressel 1 amphorae. The rim types seen at Gabii can be generically attributed to the Tyrrhenian production. The same provenance is suggested for a rim fragment relating to the more recent variants of the “late” Graeco-Italic productions (Van der Mersch/Cibecchini VIb) or to the transitional amphorae that precede the Dressel 1 (Cibecchini 2004, 5 n.16). The remaining amphora fragments are not diagnostic, but the fabrics are related to Eastern Mediterranean (perhaps also Rhodian?), North African, Adriatic and Iberian productions.

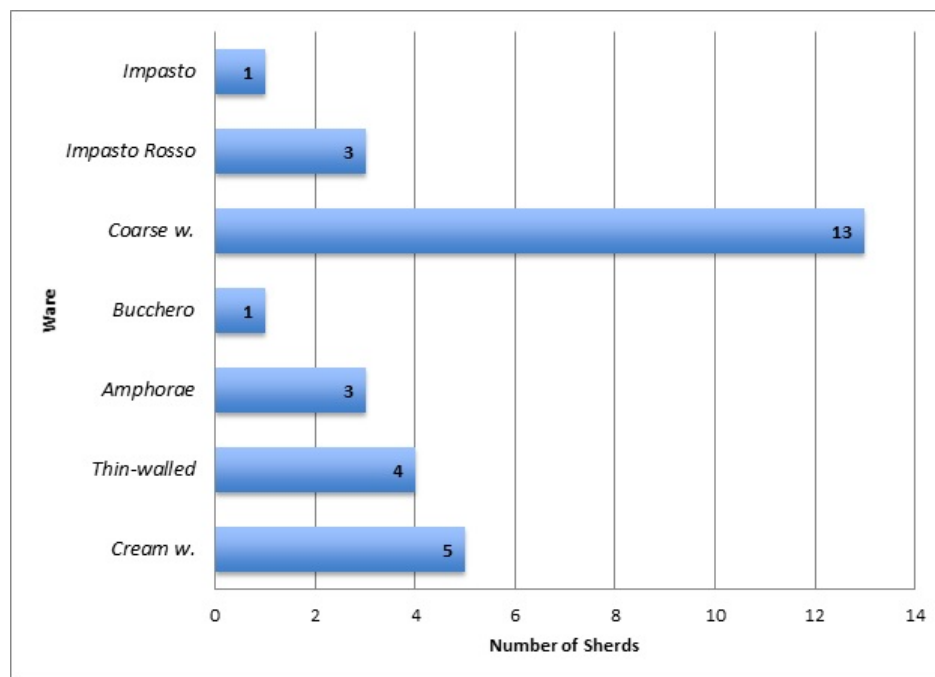
**Activity I1**– The fill connected with the construction of wall SU 1186 contained 30 sherds, corresponding to 2.89% of the Phase B-2 sample (Figure 46). The fill mostly contained residues (Impasto, Impasto Rosso, Bucchero, and some Coarse Wares). Materials generically dating to the second half of the 2nd c. BCE include Thin-Walled pottery fragments and the rim of a Dressel 1 amphora of Campanian production.



**Figure 46: Quantification of wares from the Phase 2 assemblage.**



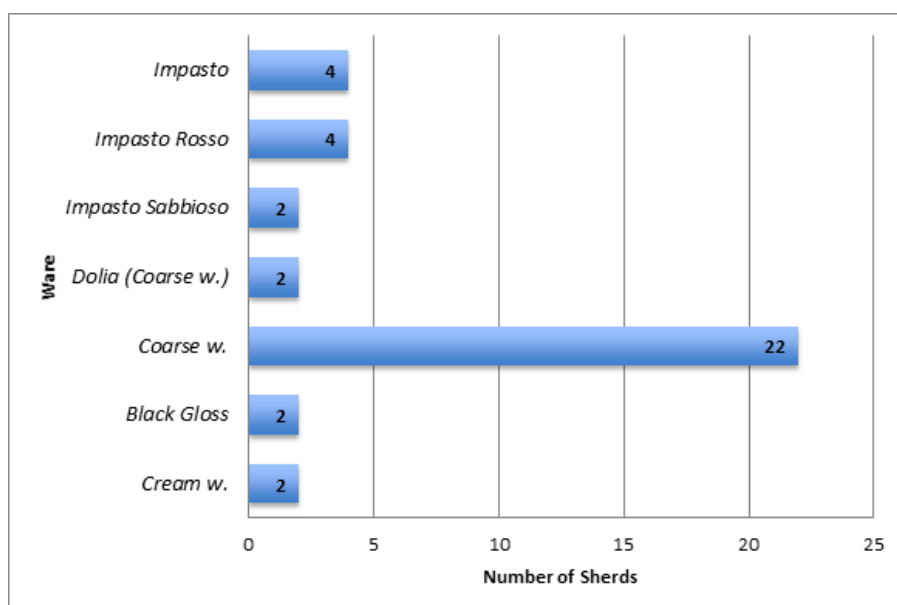
**Activity I2**– The set of materials recovered from SU 1423, which is connected with the reorganization of the main access to Room B6 from the new atrium, is larger (177 fragments, at 17.10% for the Phase; Figure 47). Impasto, Impasto Chiaro Sabbioso, Bucchero, almost all of the Coarse Ware, Cream Ware, and External Slip Ware, as well as a large proportion of the Black Gloss pottery, are residual. The diagnostic fragments, however, allow us to refine the terminus post quem provided by the finds from Activity H1. Fragments of ovoid beaker type Ricci I/7 (Marabini III), also present in the latter context, indicates a date to after the middle of the 2nd c. BCE. The Black Gloss lamp of type Ricci F, however, postdates 130/110 BCE (Ricci 1973, 219-222). Another lamp fragment from the assemblage has been tentatively assigned to the Dressel 3A type, which is a transitional shape between the Late Republican and the Augustan productions. If the identification was confirmed, this would represent the latest find from the Phase B-2 sample, which would have to be dated to the Sullan period. The rim of a Dressel 1B amphora, the only clearly identifiable, is consistent with a late 2nd or early 1st c. BCE horizon.



**Figure 47: Quantification of wares associated with Activity I2.**

**Activity I3**– The fill of a foundation trench of wall SU 1435 in the southern addition contained a mere 5 fragments, which are either residual (Impasto Chiaro Sabbioso, Black Gloss) or of uncertain chronology (Coarse Ware). Therefore little can be said about the chronology of this activity.

**Activity J1**– The preparation of a crushed tufo floor (SU 1455) in the courtyard/southern addition yielded 38 fragments (3.62% of the Phase B-2 sample; Figure 48). The majority of the finds are residual (Impasto, Impasto Rosso, coarse ware dolia and Mid-Republican Black Gloss), while some Coarse Ware and Cream Ware fragments are of uncertain chronology. As for activity I3, little can be concluded.



**Figure 48: Quantification of wares associated with Activity J1.**

In summary, the deposits associated with Activities H1-J1 featured a significant quantity of residual inclusions, but useful elements to define a terminus post quem for the Phase are available (Table 25). The datable elements derive from ceramic classes whose diffusion started in the late 2nd c. BCE and peaked in the early 1st c. BCE. Among the finewares, the most representative class is the Late Republican Red Slip Ware, a contemporary Roman production that has been recently identified. The fragment of a Dressel 1B amphora is consistent with this chronology. The lamps seem to provide a slightly later date: the Ricci H type is common from the Sullan period onwards, though earlier examples are known from Delos in the late 2nd c. BCE. The Dressel 3A variant can be securely dated to the Sullan period, but the fragment from Activity I2 can only be tentatively identified with the type.

| Act. | Class                         | Production       | Shape | Type           | Observations | Chronology                                 |
|------|-------------------------------|------------------|-------|----------------|--------------|--|
| H1   | Late-Republican Red Slip Ware | Etrusco-latinal  | open  | non id.        |              | fine II/inizio I – 50/30 a.C. (?)          |
| H1   | Lamps                         | Etrusco-latinal  |       | Ricci H        |              | post (fine II sec. a.C.?) - età sillana    |
| I2   | Lamps                         | Etrusco-latinal  |       | Dressel 3A (?) |              | 80/70 a.C. – età augustea                  |
| I2   | Amphorae                      | Tyrrhenian Italy |       | Dressel 1B     |              | fine II/inizio I sec. a.C. – età augustea. |

**Table 25: Diagnostic elements associated with Phase 2.**

### Phase 3 (second quarter/middle of the 1st c. CE)

The contexts from the last phase of activity discussed in this volume contained the largest quantity of excavated materials (Table 26 and Table 27, Figure 49): 8,576 sherds, corresponding to 60% of the entire collection of finds from the Tincu House. Despite the large sample size, relatively few elements are available to fix a terminus post quem, because the assemblage is dominated by residues from earlier periods. In fact, fragments from construction levels (activity K; Table 26) amount to a mere 3% of the Phase B-3 sample. Most of the material comes from extensive layers that obliterate the structures of Phase B-2, marking the final abandonment of parts of the house (activity L; Table 27), making up 86% of the total. Anthropogenic activities in this phase are very limited, and are related to spoliation (activity M: 1.24%) or to cuts of uncertain function (O: 0.6%). The latest levels sealing the structures are layers of colluvium of natural origin, which included a fair amount of re-deposited material (activity N: 9.18%).

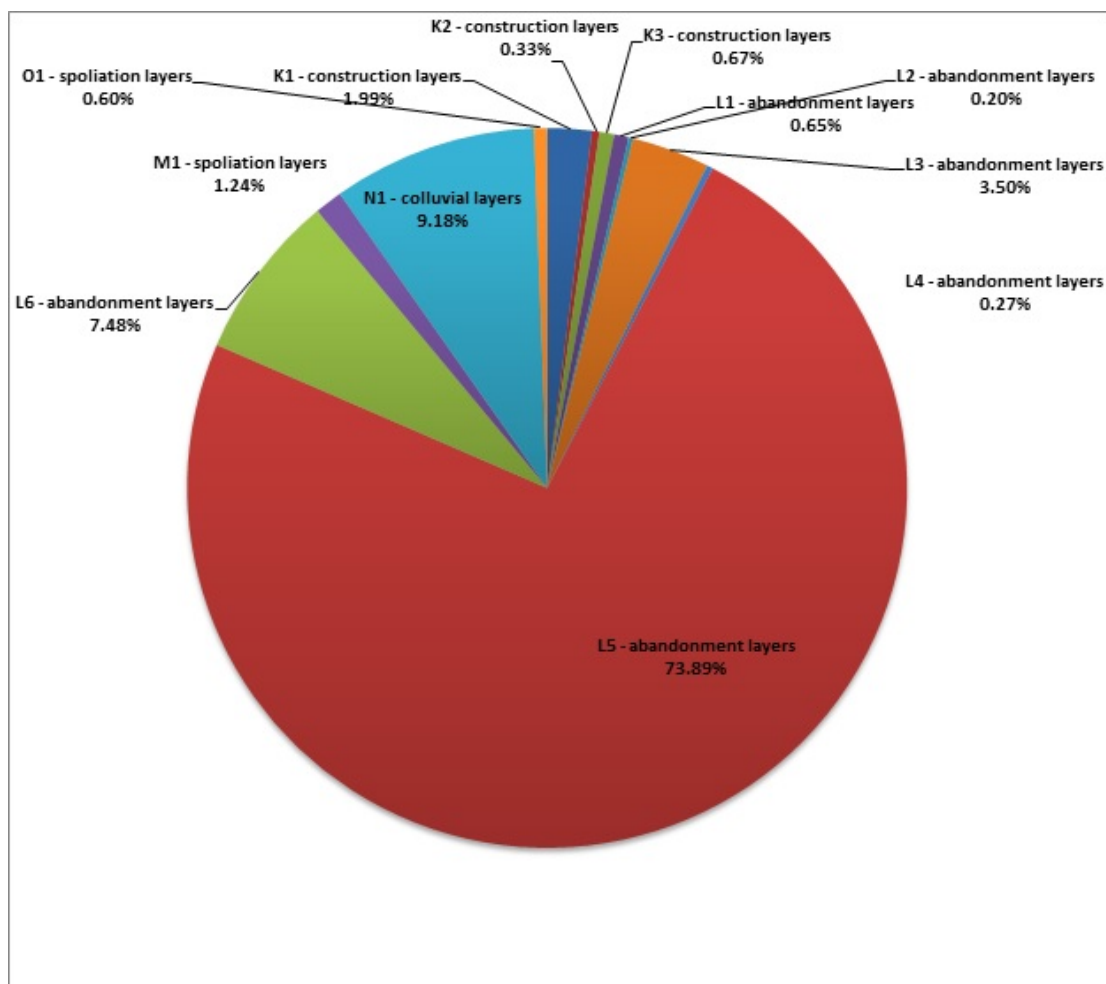
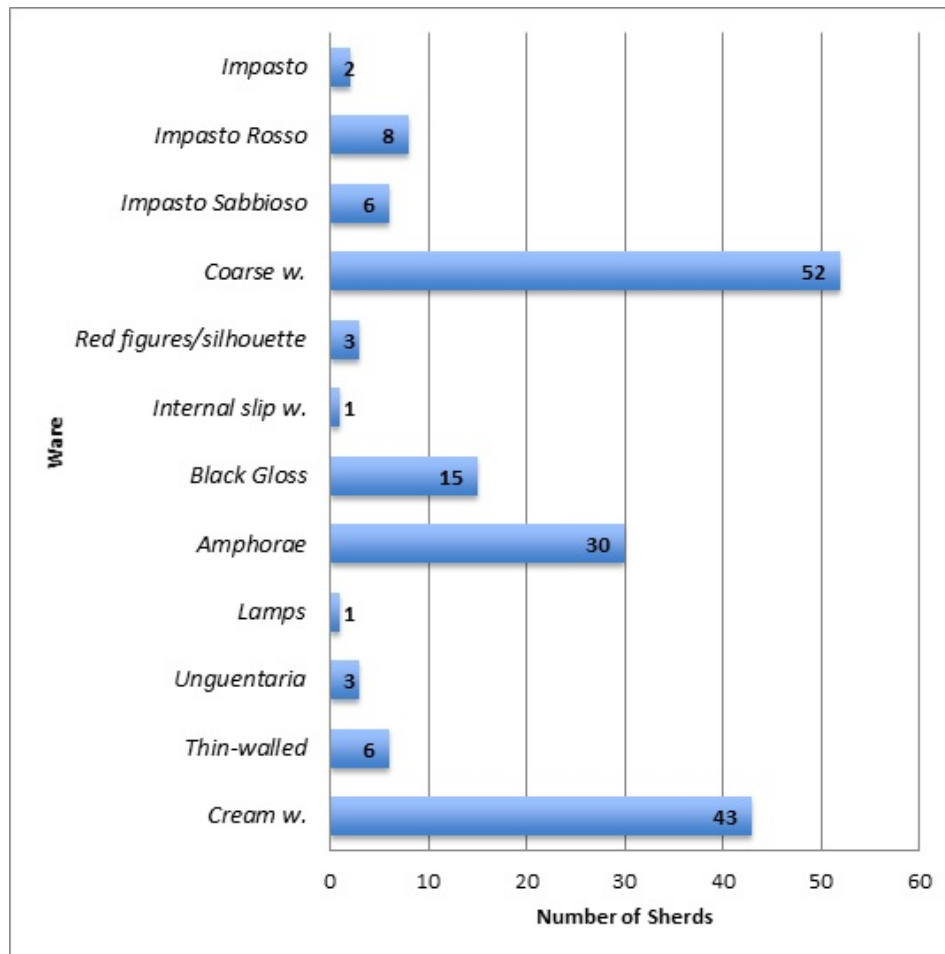


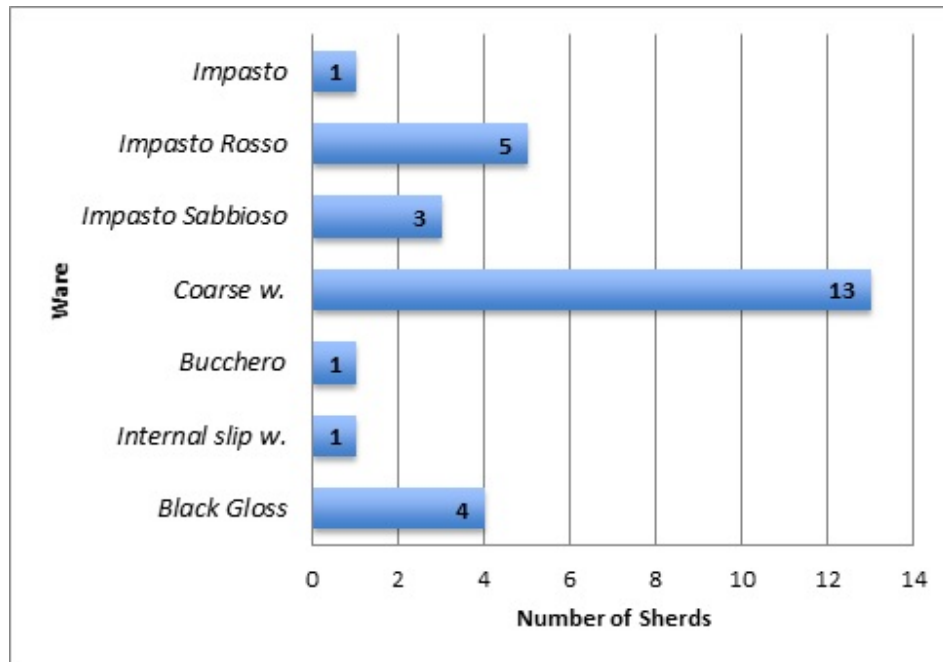
Figure 49: Proportion of sherds from each activity associated with Phase 3.

**Activity K1**– SU 1174, one of the fills of the courtyard connected with the construction of wall SU 1058, yielded 202 sherds (1.99% of the Phase B-3 assemblage; Figure 50). Almost all the material is residual from both Phase B-0 and Phases 1-2. The latter group includes fragments of a Genucilia plate with geometric decoration, which are found at sites in Etruria and Latium from the early 3rd c. BCE onwards (Ferrandes 2015; Ferrandes 2016). Coarse Ware and Cream Ware fragments mostly belong to types with long circulation periods, so their interpretation is uncertain. The same is true for the wall fragments of vessels from classes that were still being produced at the time of the deposit formation.



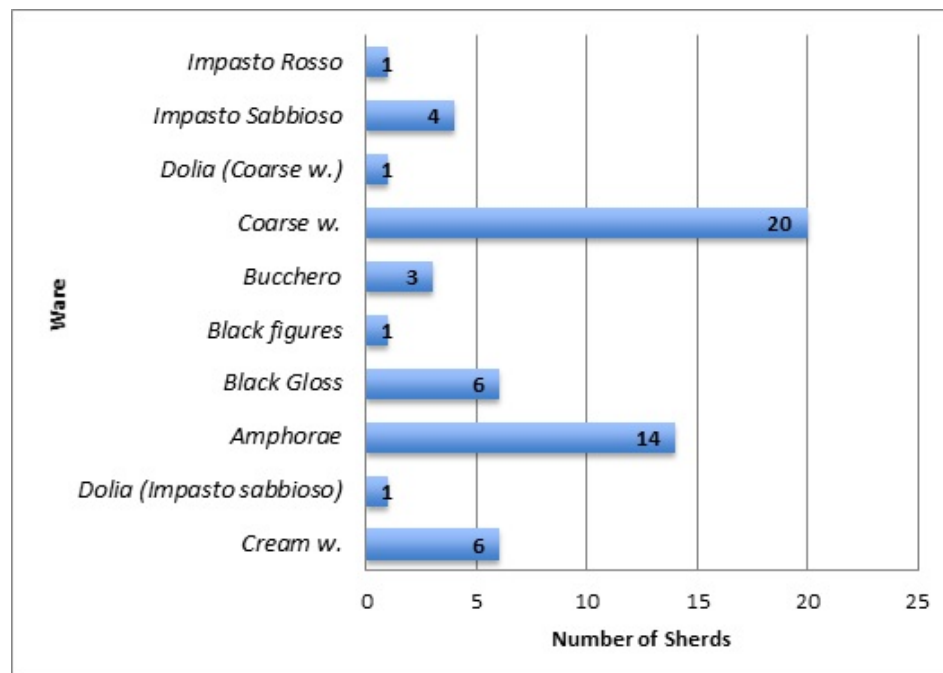
**Figure 50: Quantification of the sherds per ware in the Phase 3 assemblage associated with activity K1.**

**Activity K2**– SUs 1176 and 1189, which are associated with the construction of wall SU 1163 in between Rooms 1-2 yielded 28 fragments in total (0.33%; Figure 51). The overall composition of the assemblage is similar to that of the finds from Activity K1, as it mostly includes residual ceramics from the Archaic through the Late Republican periods. The relative distribution of the pottery classes finds a parallel with that documented for Phase B-2 contexts, suggesting that the Phase B-2 levels were extensively reworked in the context of the new construction activities. This parallels the situation we see in the transition from Phase B-0 to Phase B-1.



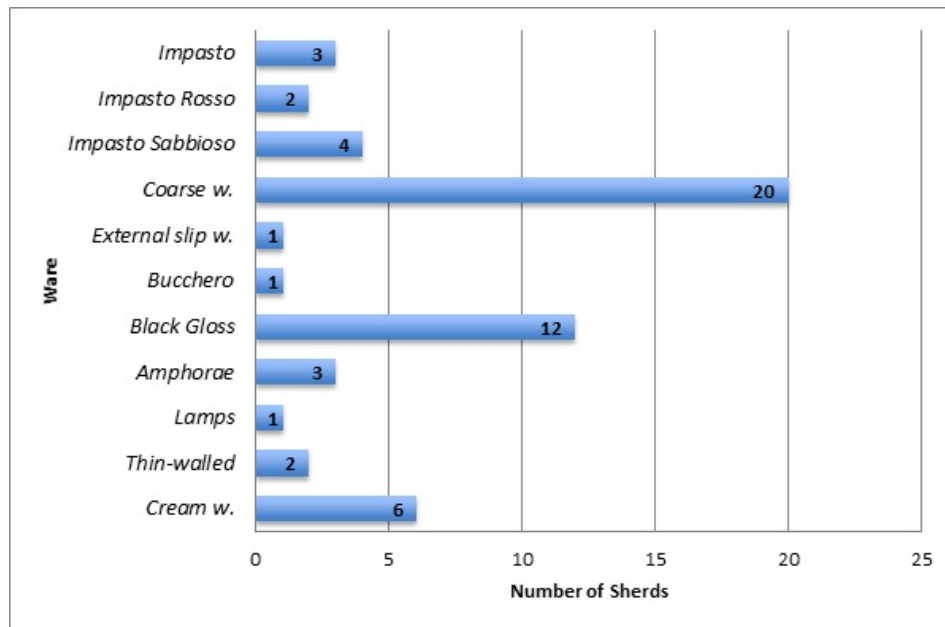
**Figure 51: Quantification of the sherds per ware in the Phase 3 assemblage associated with activity K2.**

**Activity K3** - SU 1406, a layer connected with the construction of wall SU 5146 in the southeast sector of the building, shares the same features of Activities K1-K2 (Figure 52). The latest material includes Late Republican pottery classes. A unique find from this level is a very poorly preserved fragment of an Attic Black Figured kylix of uncertain production and date.



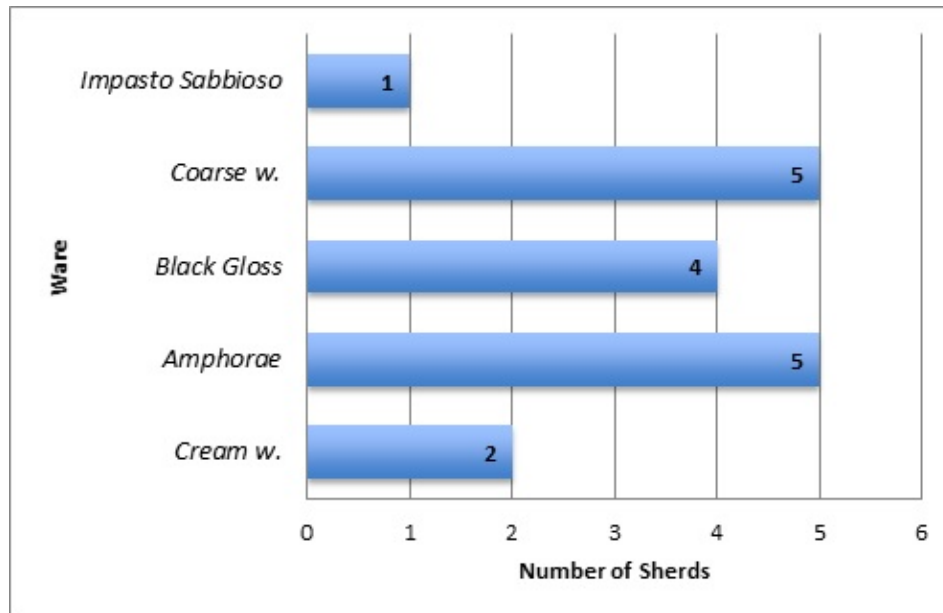
**Figure 52: Quantification of the sherds per ware in the Phase 3 assemblage associated with activity K3.**

**Activity L1** - The dump SU 1401, located along the west wall of the courtyard, represents the first in a long series of accumulations within various areas of the Tincu House, whose deposition reflects the progressive abandonment of the building. This layer contained 55 fragments (0.65% of the Phase B-3 sample), dominated by Coarse Ware (Figure 53; the SU includes also a high proportion of faunal remains). The material is generally residual, although types in circulation over an extended period are also present. As is the case for Activities K1-K3, the latest ceramics date to between the middle and late 2nd c. BCE, thus suggesting that the material originated from the destruction and reuse of Phase B-2 strata.



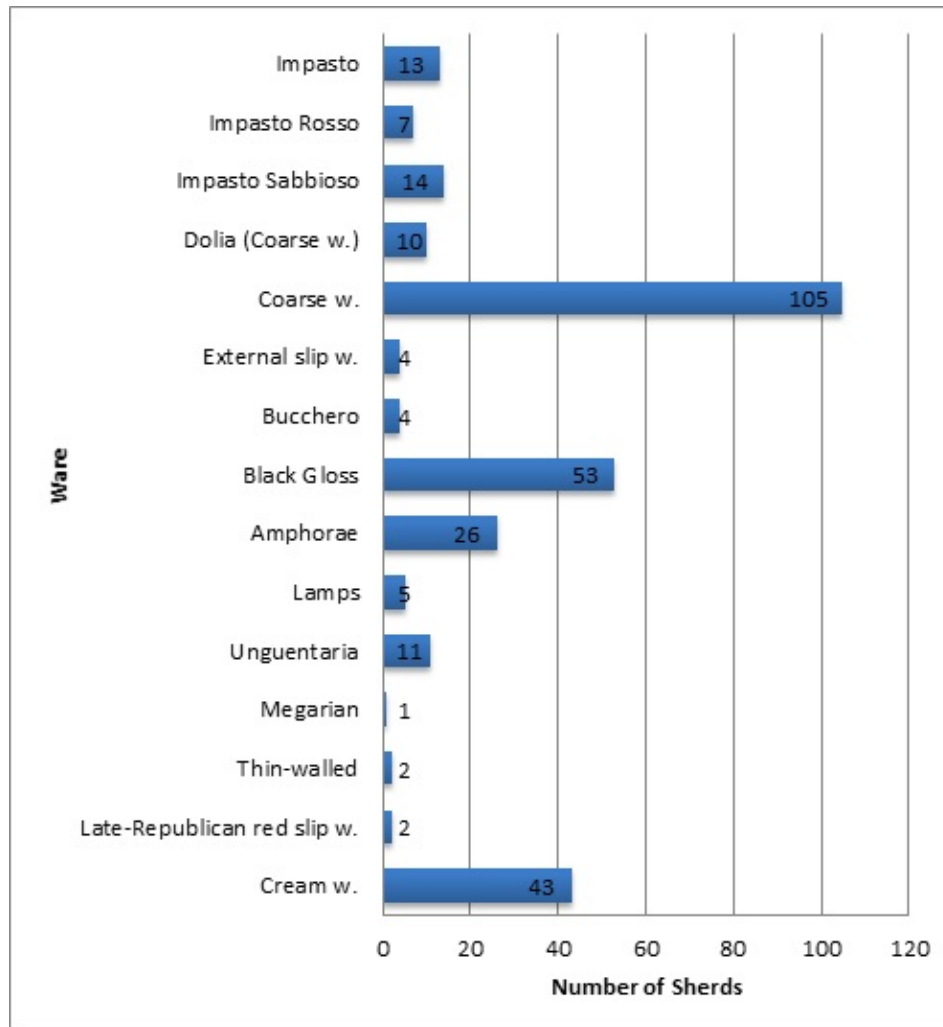
**Figure 53: Quantification of the sherds per ware in the Phase 3 assemblage associated with activity L1.**

**Activity L2** - SU 1221, soil accumulated in the drain SU 1228 in the courtyard included 17 fragments (0.20% of the Phase B-3 assemblage) (Figure 54). The few pottery fragments can be interpreted as residual materials. A notable inclusion is the base of a Black Gloss vessel of Arretine production featuring the stamp Q.AF. on the floor. This is one of the most frequently recorded names for the production, appearing in the first quarter of the 1st c. BCE and becoming more common around 60/50 BCE (Morel 2009; Brecciaroli Taborrelli 2013; reference to imports in Rome in Ferrandes 2014, 357). In light of the terminus post quem suggested for the formation of the Phase B-2 construction deposits, which is slightly earlier, the vessel in question must represent an object that was in use during the actual occupation of the building in Phase B-2.



**Figure 54: Quantification of the sherds per ware in the Phase 3 assemblage associated with activity L2.**

**Activity L3** - The dumping layers deposited within Room B5 (SUs 1232, 1242) yielded 300 fragments (3.5% of the Phase B-3 assemblage), thus representing one of the richest contexts (Figure 55). However, the composition of this subset of materials does not differ substantially from the typical assemblage of Phase B-2. These levels feature pottery classes dating to the Archaic through Mid-Republican periods, and a smaller proportion of 2nd c. BCE objects. Fragments of large bowls featuring a thin coating of opaque Black Gloss, which covers the interior floor, while on the exterior it ends irregularly just below the rim are present, a class of vessel not seen elsewhere at Gabii. Recent studies of this class of ceramics in Rome, where it is found in urban contexts dating to between the late 2nd c. and the middle of the first c. BCE suggest, based on its limited distribution, that it is intended for local consumption (Ferrandes 2014, 357-360 fig. 7.6-7). The presence of the same class at Gabii, and the technical similarities with the Roman examples, might indicate that there was a single production center whose products had a wider diffusion.

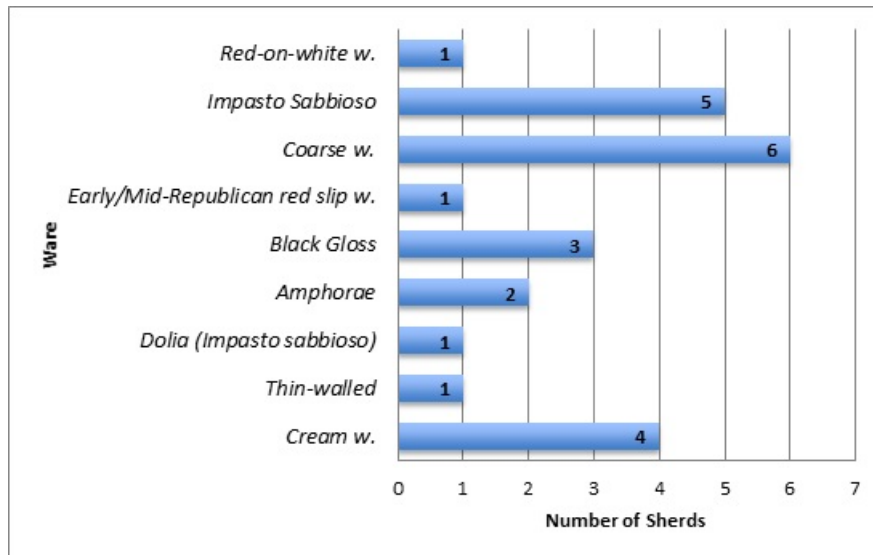


**Figure 55: Quantification of the sherds per ware in the Phase 3 assemblage associated with activity L3.**

The coins from SU 1124, two quartunciae in copper alloy are also residual (SFs 238a, dating to the late 3rd c. BCE; and 238b, perhaps 275-270 BCE). Pottery and coin evidence demonstrates that the soil dumped in Room B5 was quarried from the strata accumulated in the previous phase.

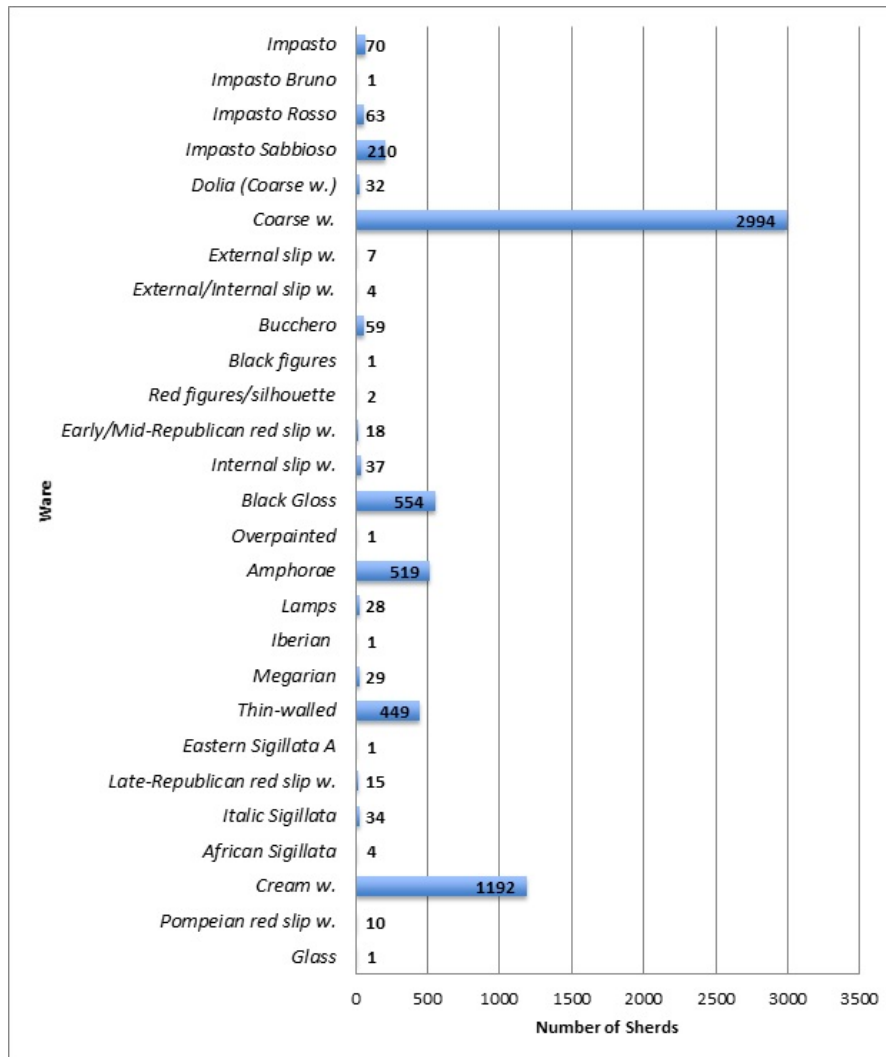
**Activity L4** - It is unclear whether SU 1222 was a layer of collapse or yet another accumulation on top of the dumps grouped under Activity L3. The sample is, in any case, of very limited value (Figure 56; 44 fragments, at 0.42%). The few datable materials are residual.





**Figure 56: Quantification of the sherds per ware in the Phase 3 assemblage associated with activity L4.**

**Activity L5** - The accumulations documented in Room B3 (SUs 1158, 1165, 1320, 1327, 1340) yielded the largest assemblage from the Tincu House (Figure 57): 6336 fragments (corresponding to 73.89% of the finds from Phase B-3 levels, and about 44% of the entire sample). The composition of the assemblage does not vary significantly from that of the other sets of materials described above, indicating a similar formation process: the destruction of deposits originally associated with the building activities of Phase B-2. On the other hand, thanks to the larger sample size, a series of diagnostic elements have been identified, which provide a terminus post quem of the middle of the 1st c. CE.



**Figure 57: Quantification of the sherds per ware in the Phase 3 assemblage associated with activity L5.**

The assemblage includes a group of finds dating from the Augustan period onwards, most notably Italian sigillata. An important element for establishing the date of the assemblage is a carinated cylindrical cup of the type Conspectus 26.2. Of a slightly later date, dating to the Tiberian period, are cups with restricted walls of the type Conspectus 32, and dishes with sloping walls of the type Conspectus 3. The element latest in date is a fragment of the hemispherical Conspectus 34 type, whose date begins around 30 CE. A generic date in the Augustan period can be proposed for fragments of lamps similar to the Bailey B type, and the Camulodunum 184 amphorae from Rhodes (the earliest examples in Rome come from the Forum of Caesar, 42-29 BCE: Zampini 2014, 189-203; the diffusion picks up beginning around 20-10 BCE, as indicated by the finds from the construction levels of the Augustan Aqua Marcia: Volpe 1996, 27, Att. 5).

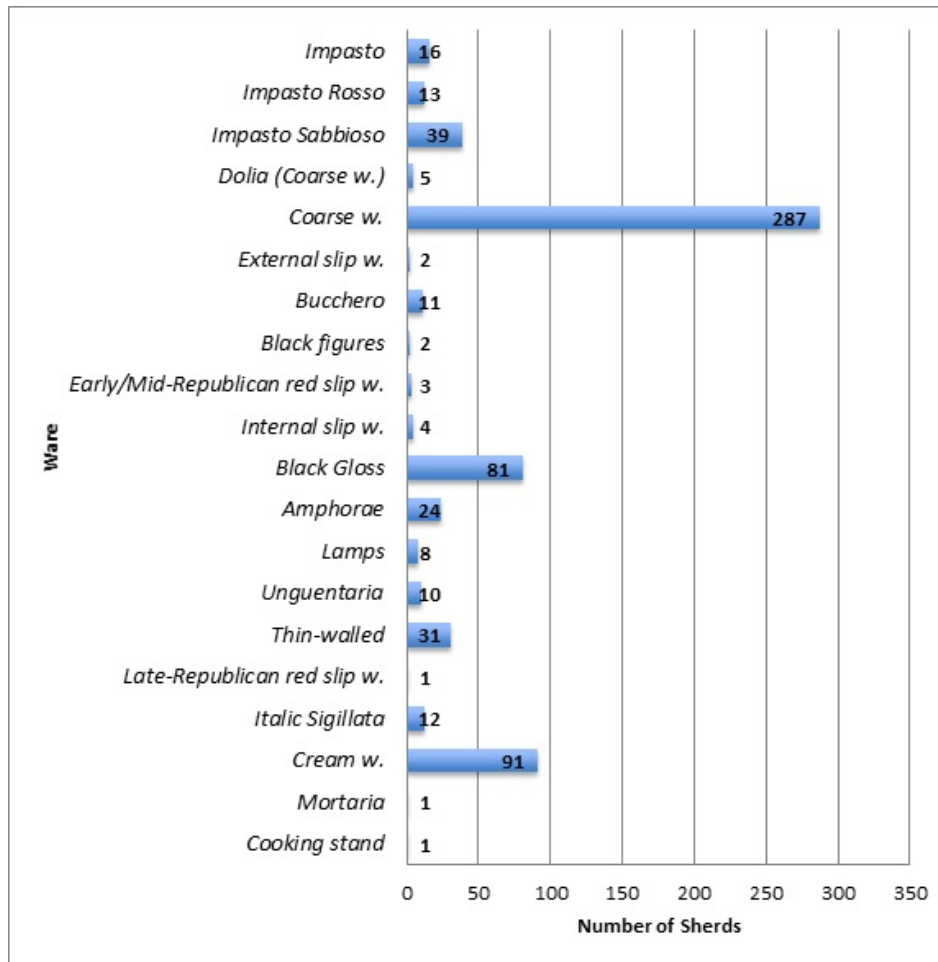
The stratigraphic position of a few fragments of African Red Slip A from one of these layers (SU 1165) is uncertain. The numerous Imperial Period tomb features that cut through the Phase B-3 sequence may perhaps explain the presence what would seem to be intrusive material. The earliest sporadic examples

of the class in Rome date, in fact, to 60/70 CE (e.g. from the stagnum of the Domus Aurea: Rizzo 2003, 107; recent unpublished finds from the north-eastern slopes of the Palatine seem to confirm this date). The progress of excavation and study of the stratigraphic sequence in neighboring city-blocks (Area A; Area F) will hopefully provide more conclusive evidence.

The coins retrieved from these deposits are also uncertain or not legible (SF 150 from SU 1158; SF 143 from SU 1165), and therefore do not add useful information on the chronology of the dumps.

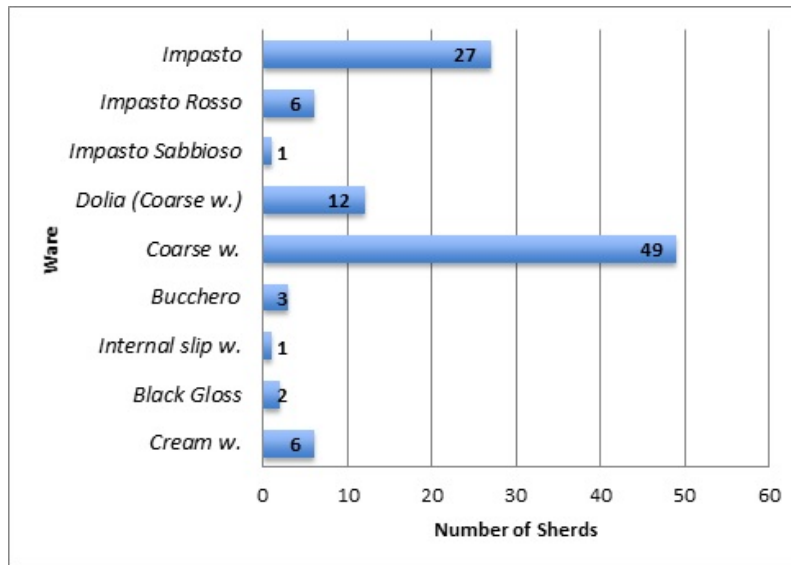
**Activity L6** - The levels obliterating the structures of Room B4 yielded 642 fragments (corresponding to 7.48% of the Phase B-3 sample; Figure 58). The overall composition of this group of materials confirms the trend identified for Activity L5: a high proportion of residual materials, including a small number of fragments related to the early phases of occupation, and frequent Late Republican finds. The sample of Italian sigillata includes some significant diagnostic elements. In addition to the carinated cylindrical bowl of the Conspectus 26.2 type, already seen in the strata formed during Activity L5, we note the bowl with a sloping wall of type Conspectus 8. Broad dishes with sloping walls of the Conspectus 3 type, dating to the Tiberian Period, and the Conspectus 32 type cup with a restricted wall, here in the variant 32.2, form part of the assemblage. Plates with vertical rims of the Conspectus 20.4 type provides a terminus post quem of 30 CE. As in the context described above, poorly preserved fragments of lamps can be generically assigned to the Augustan period onwards. Sherds of the Camulodunum 184 amphora are also present.

Finally, two coins have been recovered from these levels: a litra dating to 270 BCE (SF 268 from SU 1275) and a late 3rd c. BCE as (SF 203 from SU 1218), in copper alloy. Neither provides useful chronological information to further define the terminus post quem.



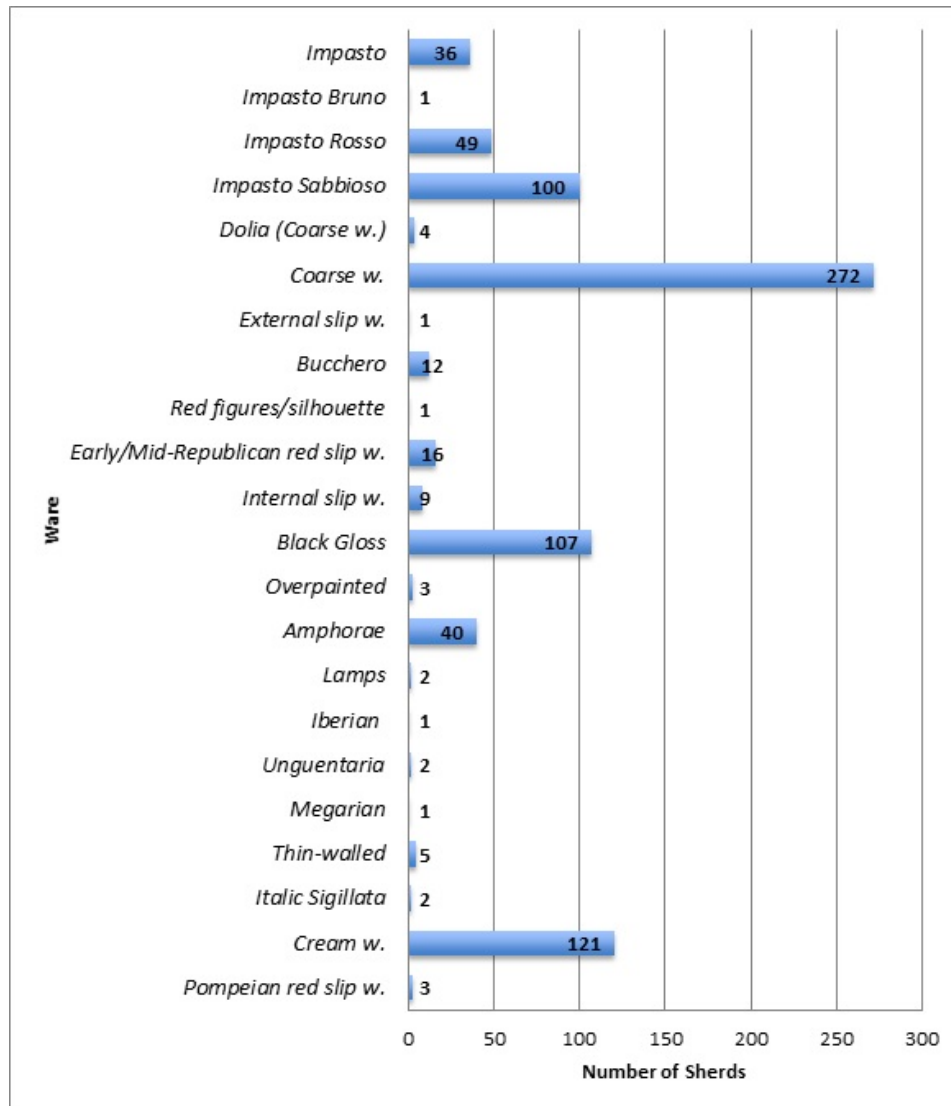
**Figure 58: Quantification of the sherds per ware in the Phase 3 assemblage associated with activity L6.**

**Activity M1** - Spoliation activities of uncertain function have been documented in both Room B3 and the atrium courtyard (SUs 1260, 1270, 1271). These features yielded 107 fragments, which correspond to 1.24% of the Phase B-3 sample (Figure 1). As other contexts from Phase B-3, the assemblage is composed of residual ceramics, in most cases predating the 5th c. BCE. The most recent finds, which are represented by Coarse Ware types of long duration, do not seem to go beyond the Late Republican period.



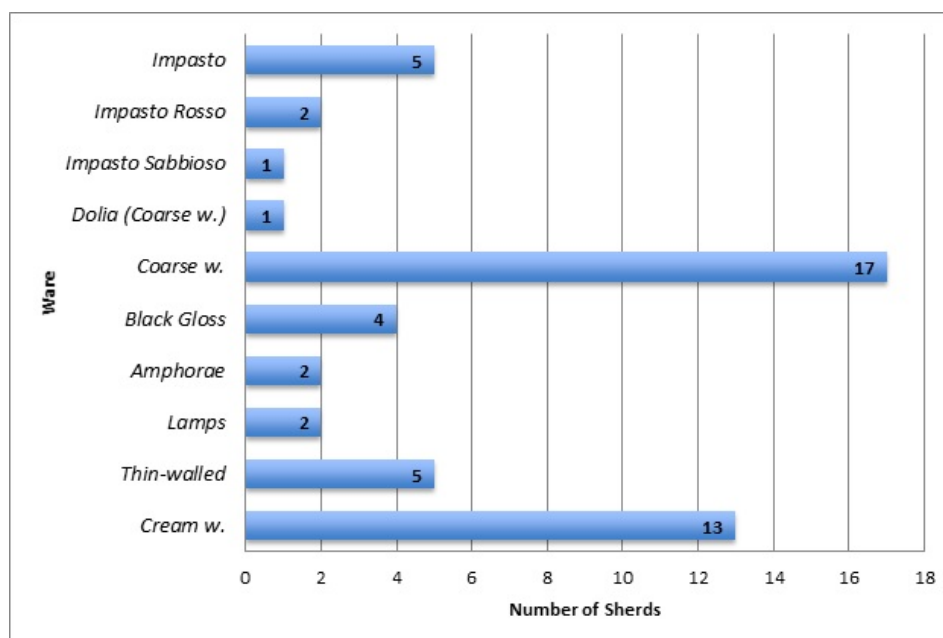
**Figure 59: Quantification of the sherds per ware in the Phase 3 assemblage associated with activity M1.**

**Activity N1** - Colluvial deposits have been identified within Rooms 1-2, the courtyard and Road 4. These layers included a fairly large amount of fragments: 1,788 sherds, about 9% of the entire assemblage of Phase B-3 (Figure 60). Residual materials are predominant, and their distribution by class is similar to that of other Phase B-3 contexts. Diagnostic elements include a lamp with volutes close to the Bailey B type, whose production started in the Augustan period, and a dish with sloping walls of the Conspectus 3 type, dating to the Tiberian period. Both types are also documented in the Activities L5-L6.



**Figure 60: Quantification of the sherds per ware in the Phase 3 assemblage associated with activity N1.**

**Activity O1** - Another spoliation feature, purpose unknown, has been identified in Room B6 (SU 1422). This fill yielded 52 fragments (0.6% of the Phase B-3 assemblage). The ceramics are once again residual (Figure 61), as is the only coin retrieved in this context (a quadrans attributed to M. Aburius Geminus, dating to 132 BCE).



**Figure 61: Quantification of the sherds per ware in the Phase 3 assemblage associated with activity O1.**

To sum up, the finds from Activities K1-O1, although quantitatively rich (more than 8,500 fragments), include only a small fraction of diagnostic materials (Table 28). A well-defined group of Italian sigillata objects, including plates with vertical rims of the Conspectus 20.4 type and hemispherical cups of the Conspectus 34 type, can be dated to 30 CE or soon after. Four fragments of African Red Slip are also attested, but their interpretation is problematic. If not intrusive, their presence would bring the terminus post quem for Phase B-3 to 60/70 CE, based on the date of the initial diffusion of the class in neighboring Rome.

| Act.    | Class                  | Production        | Shape  | Type            | Observations | Chronology            |
|---------|------------------------|-------------------|--------|-----------------|--------------|-----------------------|
| L6      | Italic terra sigillata | Italian peninsula | plate  | Conspectus 20.4 |              | 30 – 96 CE            |
| L5 - L6 | Italic terra sigillata | Italian peninsula | bowl   | Conspectus 34   |              | 30 – 96 CE            |
| L5      | African red slip       | A <sup>1</sup>    | closed | non id.         |              | 60/70 – mid-2nd c. CE |
| L5      | African red slip       | A <sup>1</sup>    | open   | non id.         |              | 60/70 – mid-2nd c. CE |

**Table 28: Diagnostic elements from Phase 3.**

## Preliminary conclusions and future directions

The study of the complex stratigraphic sequence excavated in the Tincu House has provided the opportunity to analyze a rich corpus of more than 14,000 fragments relating to the occupation of and activities taking place in the area B property between the 5th c. BCE to the 1st c. CE. While primarily

chronological in its purpose, our examination of the ceramic assemblages has laid the groundwork which will allow us to sketch a general picture of the production, import and consumption of goods at Gabii. The quantitative study of the finds has made it evident that the distribution of the sample is very uneven. Many deposits consist of just a few fragments, while other contexts yielded thousands of fragments. Because of the depositional processes at play, these larger deposits, especially in the case of Phases 2-3, included only a small fraction of finds that can be interpreted as roughly contemporary with the formation of the strata. This makes it difficult to reconstruct in any detail the actual composition of pottery assemblages for the Late Republican and Early Imperial periods. The data for Phase B-1 is, in general, much more reliable.

The original construction of the house (Phase 1A) can be dated to the second quarter or middle of the 3rd c. BCE. The circulation of ceramic classes and types at Gabii in this period finds close parallels with what is known from the main urban sites of Mid-Republican Latium. The finewares fall neatly within the material-cultural koine of the Etrusco-Latinal productions. The presence of a local workshop related to the group of the Petites Estampilles has been hypothesized for Gabii (Perez Ballester 2003, 230-236; Di Giuseppe 2012, 136). Archaeometric analyses are needed to characterize the chemical fingerprint of the local products, and verify whether the materials from the Tincu House do belong to that group.

The 3rd c. BCE contexts from Gabii include some of the earliest examples of local (or in any case Etrusco-Latinal) lamps, confirming the chronological trend seen in Rome. The diffusion of these vessels in this initial phase was extremely rare, suggesting that lighting was mainly based on the use of torches (Pavolini 1987).

Similarly, the distribution of amphorae, whose proportion correspond to about 1% of the entire assemblage, mirrors the pattern documented at Rome. Therefore, it is likely that other types of containers were used to transport wine into town (e.g., animal skin: Volpe 2009; Panella 2010).

Finally, the parallel between Gabii and other Etruscan and Latin centers is seen in the common wares used for the preparation, storage and cooking of food. The latter category, which includes some of the earliest examples of Internal Red Slip Ware, demonstrates a significant change in the technological features (e.g., fabric composition and thickness of the walls), especially when compared with the previous types of Coarse Ware and Internal Slip Ware, revealing important innovations in both the processing of the raw materials and the making and shaping of the vessels. The transition from the Archaic Impasto tradition to the Late Republican cooking wares is completed in the 2nd c. BCE, at which point the formal repertoire which characterized the Mid-Republican phase disappears, and there is no longer any technological relationship with the types of objects produced in the late 3rd c. and early 2nd c. BCE (but see the observations on Phase 1B). As already mentioned, some scholars link this transformation with the arrival of specialized craftsmen from southern Italy in the region, as a result of the conquest of Tarentum in 272 BCE.

Our knowledge of the pottery classes circulating at Gabii and in use within the Tincu House in Phase 1B is much more detailed. The fill of one of the main drainage channels of the building yielded an exceptional assemblage, both quantitatively (about 4,000 fragments) and qualitatively (residuals are all



but absent; the vessels are often fully preserved or mostly preserved and having many joining fragments). This assemblage represents one of the best contexts dating to the late 3rd and early 2nd c. BCE known from the Etrusco-Latial region. Well-dated comparative material from elsewhere in the region presents some limitations, either because of the small sample size (e.g., Rome, pavement of S. Omobono: Mercado 1963-64; Ferrandes 2006, 135), or because of the association with a large proportion of residues (Lucus Feroniae, restoration of the sanctuary: Stanco 2005; Ferrandes 2006, 135). The Gabii deposit provides much more reliable evidence, and must now serve as a reference collection for the period immediately before or after the Hannibalic war.

With reference to the finewares, it is worth noting a stronger than usual continuity of the regional Black Gloss production related to the Group of the Petites Estampilles: although the frequency of the stamped decoration decreases progressively during the second half of the 3rd c. BCE, the Gabii deposit has yielded all the known variants spanning the transition to the Late Republican tradition. The most interesting point here centers on a subset of vessels characterized by consistently similar technological (fabric and gloss) and decorative features (e.g., three radial palmettes on the floor, surrounded by a rouletted band), which would seem to indicate the existence of a single production center. The abundance of this type in the Tincu House as well as at other sites in or around Gabii (Temple of Iuno: Perez Ballester 2003, fig. 14; Ponte di Nona: Potter 1989, figs. 70.1, 71.28, 73.10, 74.14-15) may point to a local origin, but the strong affinities with contemporary materials from Lucus Feroniae complicate the picture. Only a comparative study of the collections from these two sites will tell us if we are dealing with a single manufacture, or – as was often the case in the Mid-Republican period – if the same morphological and decorative repertoire was shared by multiple Etrusco-Latial centers.

Another important observation is that the sample from the drain fill and other Phase 1B contexts feature some of the earliest examples of Thin-Walled beakers (type Marabini I). The presence of these vessel types in the early 2nd c. BCE horizon confirms the chronology proposed for the introduction of what was an innovative vessel shape, intended for the consumption of liquids.

On the other hand, lamps and amphorae continue to be poorly represented in the Gabii assemblage. In spite of their scarcity, the few elements present often serve as the most valid dating elements for the Phase 1B activities. The “late” Graeco-Italic amphorae of Campanian production indicate that wine was being imported from the hinterland of Naples (the trade was well established in the late 4th c. BCE, but peaked in the 2nd c. BCE: Bechtold 2007; Panella 2010, 21-29; 40-45). Transport containers of North-African provenance are also attested, but there is no secure evidence as to the nature of the commodity being traded in them.

The common wares for cooking, storage and food consumption show a radical break with the Archaic Impasto pottery tradition, with the exception of a few shapes (whose fabric and wall thickness are, however, completely different), demonstrating that the process of technological innovation begun during Phase 1A came to its conclusion in Phase 1B.

In contrast with the Phase B-1 assemblage, the finds from Phases 2 and 3 show a lesser degree of variability in the number of ceramic classes and productions represented. New types known to have

been first introduced in the 2nd c. BCE are present only sporadically, usually as residual materials in the Phase B-2 stratigraphy. These fragments probably originate from objects that were in use in the Tincu House after its early 2nd c. BCE restoration. Although it represents more than 60% of the excavated materials, the sample from Phase B-3 is even poorer in terms of its composition, because it primarily consists of residual elements from Phases 1A and 1B. In addition to the few diagnostic elements that provide a terminus post quem of the Phase B-3 activities, objects that can be securely dated to after 100 BCE are extremely rare. This impoverishment of the material culture from the building does not necessarily result from the nature of the deposits, but it may well reflect the change in function of the Tincu building from house to annex, which occurred in Phase B-2.

### Footnotes for Discussion of the Ceramics

[1] The argument for the primary use of ESW and ISW being food preparation is supported by the fact that in both classes the fabric is identical to that used to make coarse ware vessels that were certainly used for cooking over fire, and by the preponderance of the olla in the repertoire of forms known for both types. Further, the internal slip has been interpreted as an attempt at insulating the container in order to prevent the absorption of liquids and fats. Thus, the internal slip olla has often been referred to as an ideal vessel for cooking certain foods which tend to stick, such as the puls, or meats from which much fat is rendered during the cooking process, such as pork (Di Giuseppe 2009, 205 with further bibliography). Against this interpretation, however, it has been noted that the traces of combustion on the external surface of ISW vessels are not systematic, and that the thickness of the slip, particularly in the early production phases, is rather thin and would seem to be ineffective in providing any insulation from liquids. Proponents of this view, therefore, suggest that at least some of the production, most notably that of the larger containers, could have been used primarily for the storage of foodstuffs. In addition, the presence of numerous graffiti, particularly around the rim, and the frequent occurrence of the class at sacred sites would seem to suggest a preferential – though certainly not exclusive – use of these containers in ceremonial contexts, both for the cooking of food as gifts to the divinities, and as containers in which to hold offerings of some other nature. The miniature versions of such wares seem to be used exclusively for ritual means (Di Giuseppe 2006, 395, n. 110).

[2] Cfr. Di Giuseppe 2010, 314-31; Di Giuseppe 2014, 113-118.

[3] Murray Threipland 1963, p. 56.

[4] For examples of ISW in the stratigraphy of Building B at Veii/Piazza D'Armi see Bartoloni, Acconcia 2012, pp. 00-00. A comprehensive re-examination of the materials from Veii is in Cascino, Di Sarcina 2008.

[5] Arizza 2015 (stratigraphy) and Piergrossi, Cherubini 2015 (materials and chronology). The building has been interpreted as a temple. Some observations on the reliability of the stratigraphic sequence and the statistical sample used for the seriation of ISW types can be found in Ferrandes 2016b, p. 00.

[6] For the most recent excavations conducted in the sanctuary of the Foro Boario see Terrenato et al. 2012 with bibliography. ISW fragments have been recovered from layers dating to the first half of the 5th c. BCE (Luca De Luca, personal communication).

[7] This is part of a project led by N. Terrenato (University of Michigan) and P. Brocato (Università della Calabria) on behalf of the American Academy in Rome aimed at the systematic review of the documentation and finds of the excavations conducted by F. Brown at the site. The presence of fragments of coarse wares with internal slip in contexts of the first half of the 5th century has been brought to my attention by Carlo Regoli and Luca De Luca.

[8] On the research project directed by Clementina Panella in the last 30 years along the western side of the Colosseum valley and on the northeastern side of the Palatine See Scavare nel Centro di Roma 2013 and updated comments in Panella et al. 2014, with extensive bibliography. For a broader overview of the Mid-Republican phases see Ferrandes 2016a.

[9] For a preliminary discussion of the presence of this pottery class in the Mid-Republican layers at the north-eastern Palatine site see Ferrandes 2015 and, more extensively, Ferrandes 2016a. A detailed analysis of aspects of production, morphology, and chronology of the class was recently carried out by Alessandra Vivona in her MA thesis in Classical Archaeology titled 'Ceramiche d'impasto a Roma tra la prima e la media età repubblicana. Il controverso caso dell'Internal Slip Ware tra dati acquisiti e nuove conoscenze', which was successfully defended at the University of Rome, La Sapienza in the academic year 2015-16.

[10] For a more detailed discussion see Ferrandes 2015, pp. 00-00; Ferrandes 2016a, pp. 00-00.

[11] Fiano 2016, pp. 00-00 discusses the problems posed by the lack of Aegean imports for the absolute dating of Late-archaic contexts.

[12] Becker et al. 2009; Becker and Mogetta 2014, with bibliography.

### ***Typological references***

Bailey = Bailey 1980.

Camulodunum = Hawkes, Hull 1947.

Conspectus = *Conspectus* 1990.

Dressel (amphorae) = Dressel 1899, tav. 2.

Dressel (lamps) = Dressel 1899, tav. 3.

Morel = Morel 1981.

Ricci (thin wall) = Ricci 1985.

Ricci (republican lamps) = Ricci 1973.

van der Mersch = van der Mersch 1994 e 2001.

van der Mersch/Cibecchini = Cibecchini, Capelli 2013.

## References

- Almagro Gorbea, M. 1982. *El Santuario de Juno en Gabii*, Roma.
- Arizza, M. 2015. "Una struttura templare in opera quadrata sul Quirinale. Lo scavo, il contesto e l'interpretazione dei resti: una analisi preliminare", in Arizza, Serlorenzi 2015, pp. 64-91.
- Arizza, M. and M. Serlorenzi (eds.) 2015. *La scoperta di una struttura templare sul Quirinale presso l'Ex Regio Ufficio Geologico*, Atti della Giornata di Studi (Roma, 16 ottobre 2013), Roma.
- Bailey, D.M. 1980. *A Catalogue of the Lamps in the British Museum, 2. Roman Lamps made in Italy*, London: British Museum Publications.
- Bartoloni, G. and V. Acconcia (eds.) 2012. *L'abitato etrusco di Veio. Ricerche dell'Università di Roma 'La Sapienza'. II - Un edificio tardo-arcaico e la sequenza stratigrafica*, Roma: Iuno Editore.
- Bechtold, B. 2007. "Alcune osservazioni sui rapporti commerciali fra Cartagine, la Sicilia occidentale e la Campania (IV-metà del II sec. a.C.): nuovi dati basati sulla distribuzione di ceramiche campana e nordafricane/cartaginesi", *BABesch* 82, 51-76.
- Becker, J.A., M. Mogetta and N. Terrenato, 2009. "A New Plan for and Ancient Italian City: Gabii Revealed", *American Journal of Archeology* 113(4), 629-642.
- Benoit, F. 1961. *L'épave du Grand Congloué à Marseille*, Paris.
- Bertoldi, T. 2011. *Ceramiche comuni dal suburbio di Roma*, Università di Roma "Tor Vergata" - Studi di Archeologia - 1, Roma: ARACNE Editrice.
- Borgia, L. 1998. "Lucerne biconiche a vernice nera del Museo Nazionale Romano". *Archeologia Classica* L, 271-312.
- Brecciaroli Taborelli, L. 2013. "Per un Corpus dei bolli nominali su ceramica aretina a vernice nera", *Picus* XXXIII, 211-223.
- Carafa, P., N. Arvanitis and M. Ippoliti, 2014. Un "nuovo" santuario in *summa sacra via*, *Scienze dell'Antichità* 20.1, 143-158.
- Cascino, R. and M.T. Di Sarcina 2008. "L'Internal Slip Ware nella media Valle del Tevere", in H. Patterson and F. Coarelli (eds.), *Mercator Placidissimus. The Tiber Valley in Antiquity. New research in the upper and middle river valley*, Atti del convegno (Roma, 2004), Roma, 559-585.
- Cibecchini, F. 2004. "Affinità e divergenze nella diffusione dei materiali ceramici tra siti terrestri e relitti; alcuni problemi di interpretazione dei dati provenienti da relitti e dei flussi di distribuzione in età repubblicana", in A. Gallina Zevi and R. Turchetti (eds.), *Méditerranée occidentale antique: les échanges*, Atti del III seminario "Anciennes Routes Maritimes Méditerranéennes" (Marseille, 2004), Soveria Mannelli: Rubbettino, 57-74.
- Cibecchini, F. and C. Capelli 2013. "Nuovi dati archeologici e archeometrici sulle anfore greco-italiche: i relitti di III secolo del Mediterraneo occidentale e la possibilità di una nuova classificazione", in F. Olmer (ed.), *Itinéraires des vins romains en Gaule IIIe-ler siècles avant J.-C. Confrontation de faciès*, Actes du colloque européen organisé par l'UMR 5140 du CNRS (Lattes, 2007) (Monographies d'Archéologie Méditerranéenne Hors-série n°5), 423-451.
- Conspectus* 1990: AA.VV., 1990. *Conspectus formarum terrae sigillatae italico modo confectae*, Bonn.

- Delfino, A. (ed.) 2014. *Forum Iulium. L'area del Foro di Cesare alla luce delle campagne di scavo 2005-2008. Le fasi arcaica, repubblicana e cesariano-augustea*, BAR International Series 2607, Oxford: Archaeopress.
- Di Giuseppe, H. 2006. "Le classi ceramiche. Periodi 3 e 4 (Fasi 1-2)", in A. Caradini (ed.) with M.T. D'Alessio and H. Di Giuseppe, *La fattoria e la villa dell'Auditorium nel quartiere Flaminio di Roma*, *Bullettino della Commissione Archeologica Comunale di Roma - Supplementi* 14, Roma: L'Erma di Bretschneider, 375-402.
- Di Giuseppe, H. 2009. "Uso domestico e rituale del vasellame nella villa dell' "Acheloo", in *Suburbium* 2, 195-212.
- Di Giuseppe, H. 2010. "Incendio e bonifica prima del Foro di Cesare. Il contributo della ceramica", *Scienze dell'Antichità* 16, 303-320.
- Di Giuseppe, H. 2012, *Black-Gloss Ware in Italy. Production management and local histories*, BAR International Series - 2335, Oxford: Archaeopress.
- Di Giuseppe, H. 2014. "Periodo 2. La ricostruzione e la vita dei due edifici (prima metà IV sec. a.C.-120 a.C.). I reperti ceramici. Fase A - La sistemazione dell'area distrutta (390/380-350 a.C.)", in Delfino 2014, 101-120
- Dressel, H. 1899, *Inscriptiones Urbis Romae Latinae. Instrumentvm Domesticvm. Partis posterioris fasciculus I*, Berolini.
- Dupré, X. et al. 2000. *Scavi archeologici di Tusculum. Rapporti preliminari delle campagne 1994-1999*, Roma.
- Fentress, E. 2001. "Villas, wine and kilns: the landscape of Jerba in the late Hellenistic period", *Journal of Roman Archaeology* 14, 249-268.
- Ferrandes, A.F. 2006. "Produzioni stampigliate e figurate in area etrusco-laziale tra fine IV e III sec. a.C. Nuove riflessioni alla luce di vecchi contesti", *Archeologia Classica* 57, 115-174.
- Ferrandes, A.F. 2008. "Produzioni ceramiche a Roma tra IV e III sec. a.C. Nuovi dati", *Rei Cretariae Romanae Fautores Acta* 40, 363-372.
- Ferrandes, A.F. 2014a. "Circolazione ceramica e approvvigionamento urbano a Roma nel I secolo a.C. Nuovi dati dall'area degli *Horti Lamiani*", *Rei Cretariae Romanae Fautores Acta* 43, 353-366.
- Ferrandes, A.F. 2014b. "Complessi edilizi, stratigrafie e contesti tra Palatino e Velia: recenti acquisizioni tra media età repubblicana e tardo-antichità", in Panella et al. 2014, 179-204.
- Ferrandes, A.F. 2015. "Stratigraphical sequences and ceramic *facies* in mid republican Rome. The case of the north-eastern slope of Palatine Hill excavation", in A.F. Ferrandes and G. Pardini (eds.), *Le Regole del Gioco. Tracce Archeologi Racconti*, Roma: Edizioni Quasar.
- Ferrandes, A.F. 2016a. *Roma Mediorepubblicana. Storia di un isolato sulla via per il Foro tra IV e III secolo a.C.*, Roma: Quasar.
- Ferrandes, A.F. 2016b. "13B. *Fanum* e *sacellum* di Giove Statore (530 - 293 a.C.). Reperti datanti. Fase 12, Sottofasi 9-10", in A. Caradini, P. Carafa, D. Filippi (eds.) con M.T. D'Alessio, *Santuario di Vesta, pendice del Palatino e Via Sacra*, Roma: Quasar.
- Ferrandes, A.F. 2016c. "13C. *Fanum*, *aedes*, edificio per le *auktiones* pubbliche (293 a.C. - 64 d.C.). Reperti datanti" in A. Caradini, P. Carafa, D. Filippi (eds.) con M.T. D'Alessio, *Santuario di Vesta, pendice del Palatino e Via Sacra*, Roma: Quasar.

- Ferrandes, A.F. in prep. 1. *Il rosso e il nero. Le più antiche ceramiche fini 'verniciate' di Roma e dell'area etrusco-laziale tra V e III secolo a.C. Tipologia Produzioni Distribuzione*, Roma.
- Ferrandes, A.F. in prep. 2. "Innovazioni tecnologiche e cultura materiale a Roma e nel Lazio nella media età repubblicana. Le più antiche attestazioni di ceramica a vernice rossa interna tra archeologia e archeometria".
- Fiano, F.R. 2016. "13B. *Fanum* e *sacellum* di Giove Statore (530 - 293 a.C.). Reperti datanti. Fase 12, Sottofasi 1-8", in A. Carandini, P. Carafa, D. Filippi (eds.) con M.T. D'Alessio, *Santuario di Vesta, pendice del Palatino e Via Sacra*, Roma: Quasar.
- Finkielsztejn, G. 2001. *Cronologie détaillée et révisée des éponymes amphoriques rhodiens, de 270 à 108 av. J.-C. environ. Premier bilan* (BAR, Int. Ser. 990), Oxford: Archaeopress.
- Goudineau, Ch. 1970. "Note sur la céramique à engobe interne rouge-pompéien (Pompejanish-roten Platten)", *Mélanges de l'Ecole Française de Rome. Antiquité* 82, 159-186.
- Grace, V. 1985. "The middle Stoa dated by amphora stamps", *Hesperia* 54, 1-54.
- Hawkes, C.F.C. and M.R. Hull, 1947. *Camulodunum. First Report on the Excavation at Colchester 1930-1939*, Oxford.
- OK - Lyding Will, E. 1982. "Greco-italic amphoras", *Hesperia* 51, 338-356.
- Long, L. 1987. "Les épaves du Grand Congloué. Etude du journal de fouille de Fernand Benoit", *Archaeonautica* 7, 9-36.
- Manacorda, D. 1986. "A proposito delle anfore cosidette 'greco-italiche': una breve nota", in J.-Y. Empereur and Y. Garland (eds.), *Recherches sur les amphores grecques*, Actes du Colloque International (Athènes, 1984), Athènes-Paris, 581-586.
- Manacorda, D. 1989. "Le anfore dell'Italia repubblicana: aspetti economici e sociali", in *Anfore romane e storia economica: un decennio di ricerche*, Atti del colloquio di Siena (Siena, 1986), Collection de l'Ecole Française de Rome - 114, Roma: Ecole Française de Rome, 443-467.
- Mancini, A. and C. Pilo 2006. "Materiali votivi ed oggetti rituali dal Santuario Orientale di Gabii", *Siris* 7, 85-126.
- Mercando, L. 1963-64. "Saggi di scavo sulla platea dei Templi Gemelli. Area sacra di S. Omobono. Esplorazione della fase repubblicana", *Bullettino della Commissione Archeologica Comunale di Roma* 79, 35-67.
- Mogetta, M. and J.A. Becker, 2014. "Archaeological Research at Gabii, Italy: The Gabii Project Excavations 2009-2011". *American Journal of Archaeology* 118(1): 171-188.
- Morel, J.-P. 1969. "Études de céramique campanienne, I. L'atelier des petites estampilles", *Mélanges de l'Ecole Française de Rome. Antiquité* 81, 59-117.
- Morel, J.-P. 1981. *Céramique campanienne: les formes*, Bibliothèque des Écoles Françaises d'Athènes et de Rome - 244, Rome: École Française de Rome.
- Morel, J.-P. 2009. "Le produzioni ceramiche a vernice nera di Arezzo", in G. Camporeale and G. Firpo (eds.), *Arezzo nell'Antichità*, Roma: Giorgio Bretschneider Editore, 125-134.
- Murray Threipland, L. and M. Torelli, 1970. "A semi-subterranean etruscan building in the Casale Pian Roseto (Veii) area", *Papers of the British School at Rome* XXXVIII, 62-121.
- Musco, S. 2006. "La stipe di Ponte di Nona (Municipio VIII).", in Tomei 2006, 300-303.
- Musco, S. and C. Pilo 2006. "La stipe del santuario extraurbano orientale di Gabii", in Tomei 2006, 314-316.

- Naso, A. (ed.) 2004. *Appunti sul bucchero. Atti delle giornate di studio*, Firenze: All'Insegna del Giglio.
- Panella, C. 2010. "Roma, il suburbio e l'Italia in età medio- e tardo-repubblicana: cultura materiale, territori, economie", *Facta* 5, 11-124.
- Panella, C., S. Zeggio and A.F. Ferrandes, "Lo scavo delle pendici nord-orientali del Palatino tra dati acquisiti e nuove evidenze", *Scienze dell'Antichità* 20.1, 159-210.
- Pavolini, C. 1987. "Le lucerne romane fra il III sec. a.C. e il III sec. d.C.", in P. Lévêque and J.-P. Morel (eds.), *Céramiques hellénistiques et romaines II*, Besançon-Paris.
- Pedroni, L. 2001. *Ceramica calena a vernice nera. Produzione e diffusione*, Napoli: Petruzzi.
- Perez Ballester, J. 2003. *La ceràmica de barniz negro del santuario de Juno en Gabii*, Roma.
- Piergrossi, A. and S. Cherubini 2015. "I materiali ceramici", in Arizza, Serlorenzi 2015, 93-123.
- Potter, T.W. 1989, *Una stipe votiva da Ponte di Nona*, Lavori e Studi di Archeologia Pubblicati dalla Soprintendenza Archeologica di Roma - 13, Roma: De Luca Edizioni d'Arte.
- Ricci, M. 1973. "Per una cronologia delle lucerne tardo-repubblicane", *Rivista di Studi Liguri* 39, 168-234
- Ricci, A. 1985. "Ceramica a pareti sottili", in AA.VV., *Atlante delle forme ceramiche, II. Ceramica fine romana nel bacino mediterraneo (tardo ellenismo e primo impero)*, EAA Suppl. III, Roma: Istituto Poligrafico e Zecca dello Stato, 231-357.
- Rizzo, G. 2003- *Instrumenta Urbis I. Ceramiche fini da mensa, lucerne ed anfore a Roma nei primi due secoli dell'impero*, Collection de l'Ecole Française de Rome 307, Roma: Ecole Française de Rome.
- Scavare nel centro di Roma 2013* = C. Panella (ed.), 2013. *Scavare nel centro di Roma. Storia Uomini Paesaggi*, Roma: Quasar.
- Rossi, F.M. 2004, "Osservazioni sul bucchero di Roma e del Lazio", in Naso 2004, 269-273.
- Stanco, E.A. 2005. "La ceramica a vernice nera della stipe di Lucus Feroniae: analisi preliminare", in A. Comella and S. Mele (eds.), *Depositi votivi e culti dell'Italia antica dall'età arcaica a quella tardo-repubblicana*, Bari: Edipuglia, 209-218.
- Stanco, E.A. 2009. "La seriazione cronologica della ceramica a vernice nera etrusco-laziale nell'ambito del III secolo a.C.", in *Suburbium* 2, 157-193.
- Suburbium* 2 = V. Jolivet, C. Pavolini and M.A. Tomei (eds.), 2009. *Suburbium, 2. Il suburbio di Roma dalla fine dell'età monarchica alla nascita del sistema delle ville (V – II secolo a.C.)*, Roma.
- Terrenato, N., P. Brocato, G. Caruso, A.M. Ramieri, H.W. Becker, I. Cangemi, G. Mantiloni and C. Regoli, 2012. "The S. Omobono Sanctuary in Rome: Assessing eight years of fieldwork and exploring perspectives for the future, Internet Archaeology 31, [http://intarch.ac.uk/journal/issue31/terrenato\\_index.html](http://intarch.ac.uk/journal/issue31/terrenato_index.html).
- Tomei, M.A. 2006. *Roma. Memorie dal sottosuolo. Ritrovamenti archeologici 1980/2006*, Milano: Electa.
- van der Mersch, Ch. 1994. *Vins et amphores de grand Grèce et de Sicile, IV<sup>e</sup> - III<sup>e</sup> s. avant J.-C.*, Naples: Centre Jean Bérard.
- van der Mersch, Ch. 2001. "Au source du vin romain, dans le *Latium* et la *Campania* à l'époque médio-republicaine, *Ostraka* 10, 157-206.
- van Kampen, I. 2004. "I materiali dal Foro Romano e una classe di ciotole a orlo ingrossato", in Naso 2004, 269-273.
- Vegas, M. and A. Martín Lòpez 1982. "Ceramica comun y de paredes finas", in Almagro Gorbea 1982, 451-505.

- Volpe, R. 1996. "Le attività" in R. Volpe (ed.), *Aqua Marcia. Lo scavo di un tratto urbano*, Firenze: All'insegna del Giglio, 19-60.
- Volpe, R. 2009. "Vino, vigneti, ed anfore in Roma repubblicana", in *Suburbium 2*, 369-381.
- Widrig, W. and J. Freed 1983. "Roma, Loc. Tor Bella Monaca. Excavations on the ancient via Gabina. Second Preliminary report", *Notizie Scavi di Antichità XXXVII*, 141-182.
- Zampini, S. 2014. "3.5.2 I reperti ceramici", in *Delfino 2014*, 189-207.
- Zuchriegel, G. 2012. *Gabii I. Das Santuario Orientale im Zeitalter der Urbanisierung. Eisenzeitliche und archaische Funde der Ausgrabungen 1976/77*, Venosa: Osanna Edizioni.