

PROCEEDINGS

12th Italian LCA Network Conference

Life Cycle Thinking in decision-making for sustainability: from public policies to private businesses

Messina
11-12th June 2018

Edited by: Giovanni Mondello, Marina Mistretta, Roberta Salomone
Arianna Dominici Loprieno, Sara Cortesi, Erika Mancuso



Italian National Agency for New Technologies,
Energy and Sustainable Economic Development



**Life Cycle Thinking in decision-making for sustainability:
from public policies to private businesses**

Proceedings of the 12th Italian LCA Network Conference

Messina, 11-12th June 2018

*Edited by Giovanni Mondello, Marina Mistretta, Roberta Salomone,
Arianna Dominici Loprieno, Sara Cortesi, Erika Mancuso*

ISBN: 978-88-8286-372-2

2018 ENEA

Italian National Agency for New Technologies, Energy and
Sustainable Economic Development

Cover: Cristina Lanari

Editorial review: Giuliano Ghisu

Printing: ENEA Tecnographic Laboratory – Frascati Research Centre

Methanol production from CO₂: comparison of the environmental impact of different processes

Daniele Previtali¹, Giovanni Dotelli¹

¹ Politecnico di Milano, Dipartimento di Chimica, Materiali e Ingegneria Chimica "G. Natta",
Piazza Leonardo da Vinci 32, 20133 Milano, Italy

Email: daniele.previtali@polimi.it

Abstract

Methanol is the simplest organic alcohol and one of the most important substances in industrial chemistry. It is used as fuel, solvent and starting material to produce formaldehyde, methyl-tert-butyl ether (MTBE), acetic acid and dimethyl-ether (DME). On industrial scale it is produced using a gas mixture of H₂ and CO, also called syngas, in presence of a copper-based catalyst. Today methanol is primarily produced using fossil fuels. To improve the environmental impact new processes were developed during the years starting from different raw materials (i.e. biomass) or using different processes (i.e. photocatalysis). In this paper the environmental impact of different processes for the methanol production is evaluated using the Life Cycle Assessment (LCA) procedure. Relevant publications were reviewed focusing only on the environmental impact, while economical and social analysis were excluded.

1 Introduction

Today, methanol (MeOH) is one of the most important chemicals and its production has been continuously growing in last years reaching 70 Mtonne in 2014 and with a forecast demand of over 100 Mtonne in 2020 (Alvarado, 2016). It is used as solvent, fuel or starting material to produce several substances like formaldehyde, methyl-tert-butyl ether (MTBE), acetic acid (AA) and dimethyl-ether (DME) (Bozzano et Manenti, 2016). Methanol is an interesting alternative energy source and recently the methanol economy has been proposed as substitute to the hydrogen-economy since the alcohol transportation and storage is easier and the energy demand lower (Olah, 2005). Methanol has an octane number of 113, an energy density which is the half of gasoline and pure methanol engines can reach efficiency up to 44%. Moreover, methanol is a very flexible solution since could be coupled to "store" energy from different energy sources (photovoltaic, wind, geothermic, nuclear...). Another valuable alternative fuel is dimethyl-ether (DME), which is produced starting from methanol. It is a possible green substitute of liquified petroleum gas (LPG or GPL) due to its high calorific power, good chemical stability, high cetane number, low emissions and easiness to transport.

Nowadays, methanol is industrially produced starting from syngas, a mixture of hydrogen and carbon monoxide, in presence of a copper-based catalyst (Chinchen et al., 1988). The involved reactions are three:

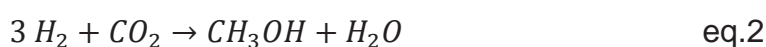

eq.1 and eq.2 are reactions for methanol production respectively starting from carbon monoxide and carbon dioxide while, the third is the water gas shift reaction (WGS). The syngas composition of fed gas for the methanol synthesis is characterized by stoichiometric number “S”:

$$S = \frac{H_2 - CO_2}{CO_2 + CO}$$

under ideal conditions S should assume a value of 2, which correspond to about 2:1 ratio of hydrogen and carbon monoxide and a maximum carbon dioxide concentration of 6-8 %vol. Today the right mechanism of CO/CO₂ hydrogenation is not so clear yet, but some studies demonstrated that under industrial conditions, CO₂ hydrogenation is the favourite mechanism. The methanol synthesis is carried out at 230-250°C, 40-100 bar and catalyst is CZA (Cu/ZnO/Al₂O₃) (Manenti et al., 2014). Different processes are studied for the methanol synthesis using photocatalysis, alternative raw materials for the syngas production or coupling the methanol production with traditional power plants as intensification process. The main goal of these studies is the reduction of fossil fuels consumption and the CO₂ reuse in order to improve the environmental impact.

In this work different LCA studies were presented to understand which processes or raw materials could improve the environmental impact of methanol synthesis.

2 Literature review

A literature review was performed considering only recent LCA studies of different technologies applied, or applicable, on industrial scale plants for the methanol production starting from CO₂ or using renewable sources. The research was limited to the years 2010 – 2017. The final selected 5 papers were resumed in table 1.

Table 1: List of selected papers

ID	Functional Unit	Process	Reference
STE	1 kg of H ₂	MeOH production using CO ₂	Sternberg et al., 2017
SLI	1 kg of MeOH 5.4 MWe	MeOH co-production using coal gasification	Sliwinska et al., 2017
REN	1 kg of MeOH	MeOH production using sugarcane waste	Reno et al., 2011
KIM	1 kg of MeOH	MeOH production using CO ₂ and solar-thermal energy	Kim et al., 2011
TRU	14.3 MJ MeOH 1 kWe 14.3 MJ of CH ₄	MeOH production using CO ₂ and photocatalytic process	Trudewind et al., 2014

In these works, it was considered the methanol production with traditional process, with the use of bio-waste, and coupled with renewable energy. The latter is one of the most interesting topic since the environmental impact of methanol is mainly caused by hydrogen production. The system boundaries of each paper are not the same, in general a “cradle-to-gate” study was done including raw material extraction, fuel consumption, construction and disassembly of plants. Every work excludes the impact of methanol use and its disposal.

a. Methanol by intensification of traditional process

Sternberg et al. (STE) performed the LCA study of the traditional process and of the new CO₂-based process. They compared the synthesis of different C1 hydrocarbons using CO₂ as starting material. The goal of the study was to understand which hydrocarbon, between natural gas, carbon monoxide, methanol and formic acid, is more effective for the global warming reduction using as reference flow the consumption of 1 kg of H₂. Methanol production was assumed by CO₂ hydrogenation at 210-250°C and 50-75 bar and then alcohol was separated by distillation. Results show that methanol produced by CO₂-based process has a global warming impact (GW) of 7.3-8.4 kg CO₂-eq per FU, while for the traditional fossil-based process the typical value is 5.3-5.7 kg CO₂-eq per FU (Figure 1).

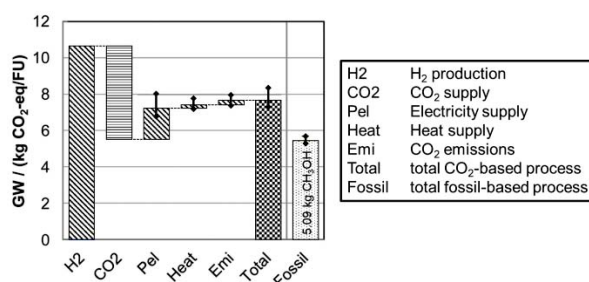

Figure 1: Methanol global warming (GW) impact per functional unit (FU = use of 1 kg of H₂). Oblique bars are supply processes with positive impact, horizontal bar is supply process with negative impact. Checkered bar is the overall new CO₂-based process while dotted bar represents the fossil-based processes. (Sternberg et al. 2017)

This is due to the high environmental impact of hydrogen production and its high energy demand. CO₂-based process could be an interesting alternative only as replacement of low efficiency fossil-based processes, in other cases the environmental impact reduction could be low or negative. In the paper, to achieve the highest global warming reduction the formic acid CO₂-based process was suggested. Methanol process CO₂-based has a positive impact on global warming, the CO₂ emissions are greater than CO₂ consumptions. Hydrogen production using renewable energy is mandatory to invert the trend (Aresta et al., 2002).

Sliwinska et al. (SLI) evaluated the environmental impact of methanol and electricity co-production starting by coal. Methanol is produced using syngas,

the product of coal gasification. Unreacted gases, after the methanol reactor, are used for electric power production. In this work the impacts were allocated in function of the amount of carbon monoxide reacted (0.43 for methanol and 0.57 for electricity). GHG emissions resulting of methanol and electricity co-production were compared with total GHG emissions generated from the production of the same quantity of methanol and electric energy using alternative reference technologies (figure 2).

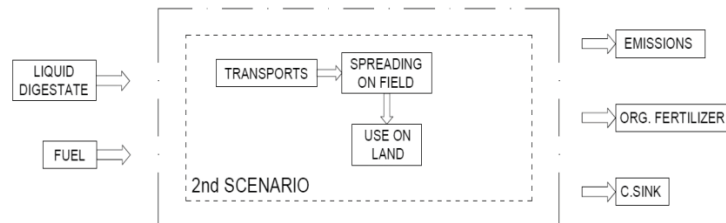

Figure 2: Greenhouse gas emissions (GHG) of co-production process. Symbols: G – analyzed technology, R – reference technology, A1 – average energy mix, A2 – subcritical coal power plant, A3 – supercritical coal power plant with CCS, A4 – IGCC power plant with CCS, A5 – nuclear power plant. (Śliwińska et al. 2017)

This new technology can reduce the GHG emissions with respect to processes that use traditional technologies (A1 and A2). Nevertheless, today development of new technologies to reduce the impact in the power sector is one of the most important goal set by IEA (IEA, 2010). For this reason, the authors considered also new technologies (A3, A4 and A5) and in these cases the co-production process result as more impactant. The co-production process could be an interesting alternative with respect to actual technologies, but the improvements are highly dependent on the alternative technology selected.

b. Methanol from biomass

Methanol production starting from biomass is another interesting way to reduce the use of fossil fuels and to promote rural development. Renò et al. studied the methanol synthesis using sugarcane bagasse as raw material (STE). Their work describes a “cradle to gate” LCA analysis considering cultivation, biomass treatments, gasification, gas cleaning, methanol synthesis and purification. Results were reported as environmental impacts and using two indicators, fuel energy ratio (FER) and life cycle energy efficiency (LCE). FER and LCE are defined by the following ratios:

$$FER = \frac{E_{fuel}}{E_{fossil}} \quad LCE = \frac{E_{fuel}}{E_{fuel} + E_{primary}}$$

For this process, FER value is 9.4, this means that only 1 MJ of fossil fuel is necessary to produce 9.4 MJ of methanol. In other words, the methanol could be considered as renewable since the energy in the methanol is higher than the fossil energy consumed to produce it. The FER value of methanol from sugarcane bagasse is also higher than that obtained producing the alcohol starting from coal or natural gas, respectively 0.39 and 0.44 (Spath and Dayton,

2003). LCE value is 0.58 due to the high demand of primary energy (biomass energy) and the high quantity of bagasse necessary to produce methanol. The efficiency of existing biomass conversion technologies is low, 2 kg of bagasse are necessary to produce 1 kg of methanol. Methanol produced starting from sugarcane bagasse is a promising alternative to coal and natural gas based process from an environmental point of view. Moreover, its impact could be further reduced improving the gas cleaning system after gasification and minimizing the use of fertilizers. Authors also proposed regulation policies to compensate the land use for biofuels production and to guarantee land for food production.

c. Methanol from solar energy

Methanol production using solar energy is based on two different approaches, the use of solar-thermal energy and the use of photocatalysts. These processes are called “Sunshine to Petrol” S2P and “Solar2Fuel” S2F. In the first case solar energy is concentrated in a thermochemical reactor to convert CO₂ into CO. Carbon monoxide is used to produce syngas by water gas shift reaction to feed a methanol reactor. The second approach is the photocatalytic conversion of CO₂ directly to methanol and methane using dye-sensitized semiconductors according with the following reactions:

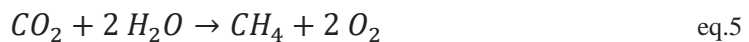

Both the processes are relatively recent and today the industrial application is limited by economical or technical issues. For the S2F process described by Kim et al. (KIM) the technical limiting factor is the thermochemical reactor which is currently under development. The S2P process is reported in Figure 3.

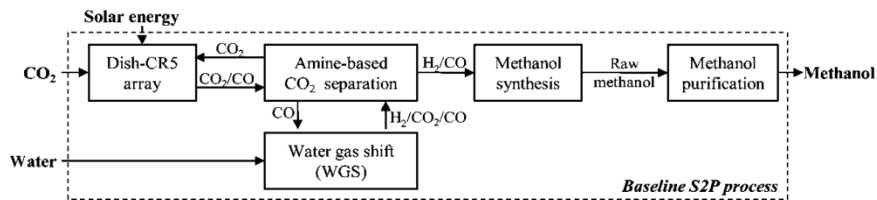

Figure 3: Flow diagram of the S2P process

CO₂ is converted into CO using Dish-CR5 array, a solar chemical heat reactor, installed on the focal of an 88 m² parabolic dish. The CO₂/CO mixture is sent to WGS reactor where hydrogen is produced and then, by amine treatment unit, CO₂ is removed. Syngas is sent to traditional methanol reactor and then the alcohol is purified using a distillation column. The environmental impact was assessed performing a “cradle to gate” LCA, and the methanol use was not taken in consideration. Three different processes were compared: traditional natural gas to methanol plant (C-NG), S2P process with utilities (heat and electricity) provided by fossil fuels (S2P-C) and S2P process with utilities provided solar energy (S2P-S).

Results show that, as expected, the less impacting process is the S2P-S (Figure 4). S2P-C process has higher global warming and acidification potential than traditional C-NG due to the high heat demand for amine treatment unit. This is confirmed by S2P-S results, in fact using renewable energy the impacts are dramatically reduced. In the C-NG and S2P-C processes the GWP and AP are mainly due to heat and electricity production (e.g., flue gases), while for S2P-S process the impacts are due to plant construction. The work shows that methanol production with S2P-S process can produce methanol with an important environmental impact improvement with respect to natural gas-based process, the net GWP is also negative and the use of fossil fuel negligible.

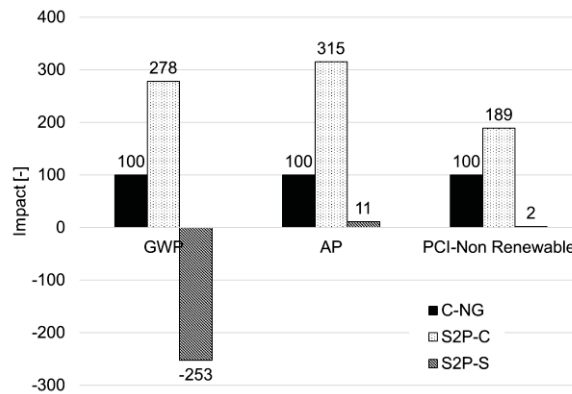

Figure 4: Environmental impact (%) of the S2P processes compared with traditional fossil fuel based process

The LCA of photocatalytic methanol and methane co-production was performed by Trudewind et al (TRU). The S2F environmental assessment was done comparing the process with traditional plant with (TR-CCS) and without (TR) carbon capture and storage. Both the traditional plants produce methanol starting from methane (Figure 5).

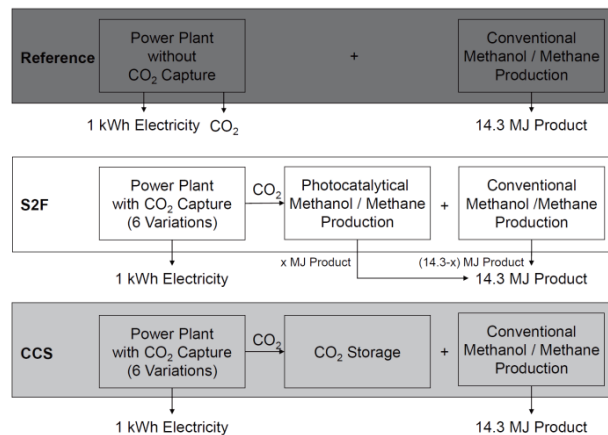

Figure 5: Configuration comparison of S2F with traditional process without CCS (Reference) and traditional process with CCS (CCS)

Results show that the primary energy demand of the traditional process without CCS (TR) is about 40% higher than photocatalytic one (S2F). TR-CCS process energy demand is slightly higher than traditional due to the capture and storage of CO₂. Nevertheless, the traditional plant has the highest GWP and TR-CCS the lowest. In the S2F process PE and GWP mainly depends on energy for methanol distillation. For all the processes the impact of power plant, utilities transport, and CO₂ storage are negligible. Acidification potential, photochemical ozone potential (POCP), eutrophication (EP) and human toxicity (HTP) are similar for all the processes. In the paper a sensitivity analysis was performed. Energy mix influence is negligible, but solar efficiency and material lifetime can double the impacts. Trudewind concludes that S2F process can reduce the environmental impacts (except POCP) with respect to traditional processes. Methanol purification section, which contributes to about 30-42 % of GWP impact, was identified to be the weakest point of S2F process.

3 Conclusions

In this work the environmental impact of different processes for methanol production from CO₂ was compared. The comparison of traditional process was performed highlighting the differences with respect to methanol produced as intensification process, starting from biomass or using solar energy. The main problem of methanol produced starting from CO₂ is that the impact is strictly linked to hydrogen production, the most impactant step. Only the use of hydrogen produced with renewable sources could produce methanol with an environmental impact lower than fossil-based processes. The synthesis starting from biomass shows interesting results, the footprint of BTL process is lower and, furthermore, it could be reduced improving some process aspects. The main issue of BTL process is the competition between land destined to fuels and to food. Finally, processes which use solar energy are the more interesting but further developments are necessary. Generally, those processes could reduce the environmental impacts, especially for global warming and fossil fuel demand, but economical and technological problems limit their application.

4 References

- Alvarado M, 2016. The changing face of the global methanol industry, IHS Chemical Bulletin, 3.
- Aresta M, Caroppo, A, Dibenedetto, A, Narracci, M, 2002. Life Cycle Assessment (LCA) applied to the synthesis of methanol. Comparison of the use of syngas with the use of CO₂ and dihydrogen produced from renewables. Environmental Challenges and Greenhouse Gas Control for Fossil Fuel Utilization in the 21st Century. Springer, Boston, MA, 2002. 331-347.
- Bozzano G, Manenti F, 2016, Efficient methanol synthesis: Perspectives, technologies and optimization strategies, Progress in Energy and Combustion Science, 56, 71-105.
- Chinchen G, Denny P, Jennings J, Spencer M, Waugh W, 1988, Synthesis of Methanol: Part 1. Catalysts and Kinetics, Applied Catalysis, 36, 1-65.
- International Energy Agency, 2010. Energy Technology Perspectives.

- Kim, J, Henao, CA, Jhonson, TA, Dedrick, DE, Miller, JE, Stechel, EB, Maravelias, CT, 2011. Methanol production from CO₂ using solar-thermal energy: process development and techno-economic analysis. *Energy Environmental Science*. 4, 3122-3132.
- Manenti, F., Leon-Garzon, AR, Ravaghi-Ardebili, Z, Pirola, C., 2014, Systematic staging design applied to the fixed-bed reactor series for methanol and one-step methanol/dimethyl ether synthesis, *Applied Thermal Engineering* 70(2), 1228-1237.
- Olah, GA, 2005. Beyond oil and gas: the methanol economy. *Angewandte Chemie International Edition*. 44(18), 2636-2639.
- Reno, MLG, Lora, EES, Palacio, JCE, Venturini, OJ, Buchgeister, J, Almazan, O, 2011. A LCA (life cycle assessment) of the methanol production from sugarcane bagasse. *Energy*. 36, 3716-3726.
- Śliwińska, A, Burchart-Korol D, Smoliński, A, 2017. Environmental life cycle assessment of methanol and electricity co-production system based on coal gasification technology. *Science of the Total Environment*. 574, 1571–1579.
- Spath, PL, Dayton, DC, 2003. Preliminary Screening - Technical and Economic Assessment of Synthesis Gas to Fuels and Chemicals with Emphasis on the Potential for Biomass-Derived Syngas. Technical Report of National Renewable Energy Laboratory.
- Sternberg, A, Jens, CM, Bardow, A, 2017. Life cycle assessment of CO₂-based C1-chemicals. *Green Chemistry*. 19, 2244–2259.
- Trudewind, CA, Shreiber, A, Haumann, D, 2014. Photocatalytic methanol and methane production using captured CO₂ from coal-fired power plants. Part I e e a Life Cycle Assessment. *Journal of Cleaner Production*. 70, 27–37.