

TECHNICAL AND ECONOMIC ANALYSIS OF THE RECONVERSION OF AN EXISTING BIOGAS PLANT TO BIOMETHANE PRODUCTION: A CASE STUDY.

G. de Notaristefani di Vastogirardi, F. Calise, M. Dentice d'Accadia
 Università degli Studi di Napoli Federico II – Department of Industrial Engineering
 P.le Tecchio, 80 – 80125 Napoli

ABSTRACT: The paper deals with the technical and economic analysis of a project aimed at transforming an existing plant, used for the anaerobic digestion of zoo-technical and agroforest biomass and including a CHP system of about 1 MW of electric capacity, into a facility producing bio-methane for automotive and/or stationary power applications. A comparison of different biogas upgrading technologies is performed, aimed at selecting the technology most appropriate to the size and typology of application under evaluation. Similarly, an analysis is performed to evaluate the opportunity of installing a bio-methane liquefaction facility, to simplify the management and transportation of the fuel, to be used in vehicles. The economic analysis is performed by considering the incentives presently available in Italy for bio-methane producers.

Different scenarios are analyzed and discussed, and it was concluded that the conversion of the existing plant into a facility to produce bio-methane to be liquified and sold as fuel for vehicles represents at this moment a very attractive and profitable option. Biomethane, biogas, biomass, digester, digestate, cogenerator

1 INTRODUCTION

Object of the following elaborate is the technical economic analysis of a biogas plant, with anaerobic digestion and its conversion to liquid bio-methane (LNG)..

The technical memory develops starting from the study of an existing 1 MW biogas plant of electric power, located in the Municipality of Latina in Borgo Bainsizza and fed with agricultural biomass derived from energy crops and by-products of agro-industry and industry food.

The paper shows a feasibility study that allows to evaluate the opportunity to find a future use for the biogas produced by the plant fermenter to date used exclusively to power the co-generator that generates the electricity to be fed into the network and the thermal energy to be supplied to a nursery-gardening user adjacent to the plant.

Therefore, a comparison was made between the various upgrading technologies in use to reconvert the plant, finalizing it to the production of bio-methane to be introduced into the network and an economic analysis was developed aimed at determining the conditions of maximum profitability of the investment. in the case of reconversion and/or expansion of the plant taking into account the indications contained in the decree of March 2018 in which MISE (Ministry of Economic Development) identifies the new parameters for access to economic incentives in particular for those existing plants that want to convert to the production of bio-methane to be fed into the network.

2 DESCRIPTION OF THE PLANT

2.1 General characteristic

The plant, owned by AGRI POWER PLUS S.r.l, has been operational since November 2011 and was the first plant built in the Province of Latina. It is aimed at the production of electricity through a co-generator fed by the biogas produced by the anaerobic digestion of the biomass stored in mesophilic conditions, with a constant temperature of 39 ° C, while the thermal energy, net of self-consumption, is sold to a floriculture company near.

2.2 Technical data

The plant was designed to generate an electrical power of 999 kW (total nominal heat output of 2.4 MWt), with an annual production of approximately 7.830.000

kWh/year, a primary energy saving of 1.712 TEP and lack of carbon dioxide emissions equal to 4.900 tons/year.

Currently the plant is structured with two digesters of 2.570 m³ each with its own storage tank for the digestate and an internal combustion engine model JMS 416 GS-b. L, powered by biogas, total rated thermal input of less than 3 MW.

2.3 Biomasses loaded and biogas production

The feeding of the plant is guaranteed by the constant loading of bovine slurry, agro-industrial by-products and corn and triticale silage, with addition of water to reach the right degree of dry substance of the incoming mixture (e.g. **Fig 1**).

Following these characteristics for the single substrate, it is possible to use anaerobic digestion in co-digestion. This very widespread solution allows the optimization of the anaerobic production process by exploiting the characteristics of each substrate by mixing them in appropriate percentages.

Consider that the availability of the substrates is subject to seasonality (especially those coming from energy crops), therefore the heterogeneity of the supply, ensured by the possibility of storage of the substrates, favors the flexibility of the plant and ensures a continuous operation (e.g. **Fig.2**)

Table I: Overview of loaded biomass

Month (2017)	solid biomass (ton)	liquid biomass (ton)	total biomass (ton)	biogas/ biomass	Biogas (m3)
Jan	1.514	432	1.946	187	360.644
Feb	1.205	292	1.497	222	330.250
Mar	1.383	340	1.722	214	367.877
Apr	1.480	266	1.746	205	352.862
May	1.583	258	1.841	203	367.350
Jun	1.261	309	1.568	235	367.043
Jul	1.510	339	1.847	207	380.443
Aug	1.646	352	1.996	204	403.545
Sep	1.168	315	1.482	190	289.272
Oct	1.376	567	1.945	198	379.726
Nov	1.261	872	2.133	169	358.697
Dec	1.459	768	2.227	169	370.786
TOTAL	16.846	5110	21.950	200	4.328.495

The production of biogas, verified on the experimental data of the last five years, can be considered constant throughout the year (e.g. **Fig.3**). In fact, the biomasses are stored in special structures to be then loaded into the reactors gradually during the year according to a dosage that can ensure a dry substance content and organic load of the material always introduced constant (e.g. **Table I**).

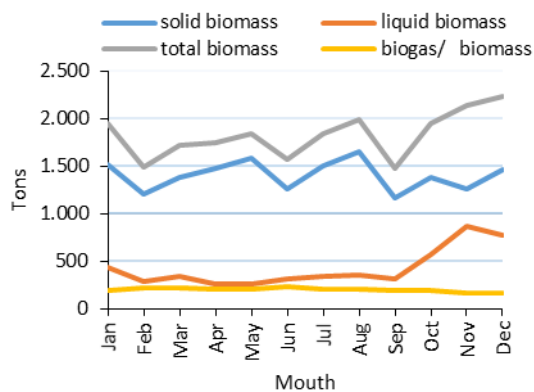

Figure 1: solid and liquid biomass ratio in 2017

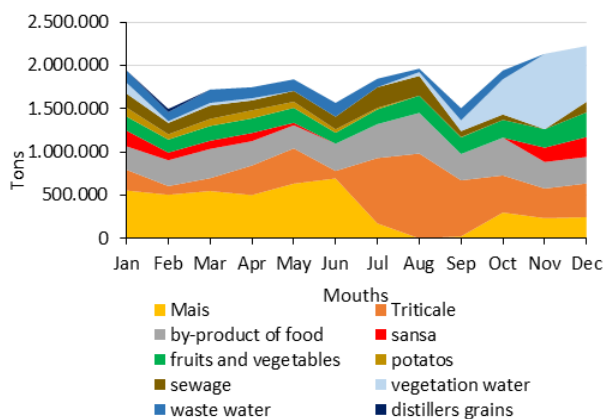

Figure 2: biomass loaded in the 2017

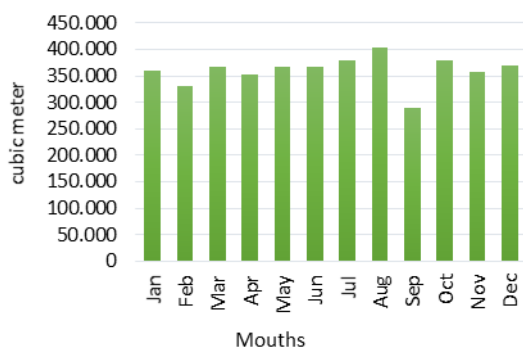

Figure 3: Biogas production in 2017

2.3 Economic analysis of plant

The operating costs and current revenues on an annual basis were analyzed below [1].

The costs have been divided into three macro-entries:

- Biomass supply costs;

- Operating costs;
- Service contracts and global service

The tables below show the costs incurred for the plant in the year 2017 (e.g. **Tab. 2**) and the detail of the supply costs for the different types of biomass (e.g. **Tab. 3**)

Table 2: details plant cost

plant management (Euro)	full service (Euro)	agriculture management contract (Euro)	global service (Euro)	biomass cost (Euro)
150.000	185.000	45.000	205.000	948.000

Table 3: costs for the different types of biomass

Biomass	Q.ty tons/year	cost Euro/ton	chopping Euro/ton	silage Euro/ton	carriage Euro/ton	Total cost Euro/year
Mais	10.800	40	5	1	5	550.800
Triticale	6000	6000	5	1	5	246.000
by-product of food	2400	50		1	5	134.400
manure	2400	1		1	5	16.800

The current revenues from the sale of the energy produced are determined by the electricity fed into the network and remunerated with the omnicomprehensive tariff (TO) by GSE equal to 0.28 Euro/kWh entered and by the transfer of the thermal energy to the neighboring floriculture company, agreed to 1 Euro/kWh (e.g. **Fig. 4**).

Figure 4: Profit of energy sales

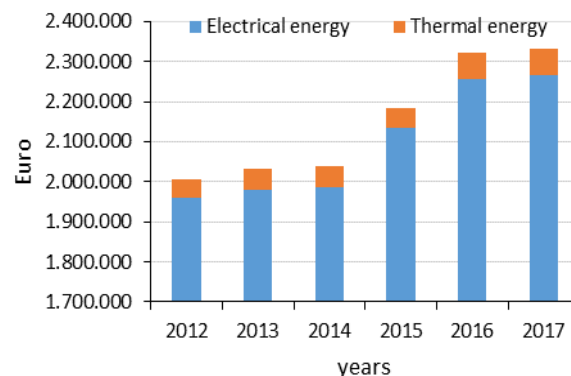

3 CHARACTERISTIC OF BIOMETHANE

The European Directive 2003/55 have authorized the injection of other types of gas in the nets natural gas. Particularly interesting it is the possibility to also inject you the biomethane that is a refined biogas with quality comparable to those of the natural (concentration of superior CH₄ to 95%) gas and, therefore, used in substitution of the fossil in all of his/her applications of net and in the transports.

The produced biogas can not be used as fuel in the raw state, it is necessary that its composition meets the requirements for specific use (gas stoves, engine of a vehicle, introduction into the natural gas network, fuel

cell, etc.).

The purification of harmful components present in low concentrations is normally referred to as *cleaning*, while to increase its calorific value, proportional to the concentration of methane, CO₂ must be removed.

The term *upgrading* means precisely the process of removing carbon dioxide from the gas until the level of methane approaches that of natural gas (> 90%).

The percentage of methane in biogas depends on the process conditions but above all depending on the raw material that can lead to a volumetric content of CH₄ oscillating between 50 and 70% [2].

The purification treatments are therefore aimed at increasing the concentration of methane to values even greater than 98% selectively separating the unwanted substances from it.

An example of a biogas composition obtained by anaerobic digestion is shown in following table where is made a comparison with natural gas (e.g. **Table III**).

Table III: comparison between the composition of biomethane e natural gas [3]

Elements	Biogas	Natural gas
Methane	50-70%	93-98%
Ethane	/	<3%
Propane	/	<2%
Azote	<3%	<1%
O ₂	<2%	<1%
carbon dioxide	25-40%	
Water	2-7%	
Hydrogen sulphide	<1%	
NH ₃	<1%	
Siloxanes	tracks	

4 REFERENCE LEGISLATION

The Ministerial Decree of 2 March 2018 favors, the conversion of existing plants through the following as it recognizes the following possibilities (e.g. **Table IV**):

- For existing plants that benefit from incentives on electricity produced, to continue to benefit from the electricity incentive, for the entire residual period of not less than 3 years from the date of entry into service in reconverted state, up to a value not exceeding 70% of the average annual incentive production, measured from the date of entry into service in an electric only structure;
- An incentive period equal to the remaining period of entitlement to incentives for the production of electricity increased by 10 years if the plant to be reconverted is taking advantage of the electricity incentive;
- CIC increase for plants with a biomethane liquefaction system;
- Same determination of the CICs of new plants for plants converted to biomethane.

100% of the CIC, Certificate of Entry into Consumers, for a period of entitlement equal to a new plant, is assigned to biogas plants totally or partially

Table IV: Method of determining the CIC due to the plant [4]

Tipologia impianto	SEZIONE A Determinazione del numero dei CIC spettanti al produttore di biometano			SEZIONE B Determinazione della maggiorazione prevista da articolo 5, commi 8 e 9		
	L'impianto di produzione del biometano è alimentato:	Gcal/CIC	I certificati vengono rilasciati su una quota percentuale del quantitativo di biometano immesso in consumo nei trasporti	Durata	Determinazione	
ricoverito	esclusivamente da biomasse di cui all'art. 5, comma 5	5	100%	20 anni dalla data di decorrenza del periodo di incentivazione o periodo residuo di incentivazione per l'energia elettrica incrementato di 10 anni ³	50% del numero CIC spettanti non comprensivi di maggiorazioni	Fino al raggiungimento del 70% del valore del costo di realizzazione dell'impianto di distribuzione di gas naturale e comunque al massimo entro un valore di 600 mila euro ⁴ e fino al raggiungimento del 70% del valore del costo di realizzazione dell'impianto di liquefazione e comunque al massimo entro un valore di 1,2 milioni di euro ²
	da biomasse di cui all'art. 5, comma 5 in codigestione con altri prodotti di origine biologica, questi ultimi in percentuale inferiore o uguale al 30 % in peso	5	70%			
	da biomasse di cui all'art. 5, comma 5 in codigestione con altri prodotti di origine biologica, questi ultimi in percentuale superiore al 30 % in peso	10	30%			
	da biomasse di cui all'art. 5, comma 5 in codigestione con altri prodotti di origine biologica, questi ultimi in percentuale superiore al 30 % in peso	10	100%			

converted to the production of advanced biomethane and biomethane to be fed into the network for transportation purposes.

In the case of existing biogas electric power generation plants, which benefit from incentives on the electricity produced and that as a result of the conversion to biomethane want to maintain part of the production of this electricity, the provisions referred to in this paragraph shall apply if the manufacturer accepts the following conditions:

- After the conversion, the incentive due on the residual production of electricity is paid, for the entire residual period of law, which must not be less than three years from the date of entry into service in reconverted structure, on a non-production quota more than 70% of the average annual incentive production;
- The minimum period of three years of disbursement of the incentive due on the production of electricity from the date of entry into service in a converted structure is reduced to two years in the case of biogas plants that have entered service by December 31, 2007.

5 RECONVERSE OF THE PLANT

The reconversion project of the plant object of the present technical memory starts from the necessity to find a new use, in the long term, at the cessation of the electrical incentive currently used by the plant.

The case studies all foresee a new feeding plan for the plant in order to maximize the proceeds obtained through the CIC which are about twice the case in which the by-products did not reach 70% of the total biomass used.

We have studied six configuration of the plant, cases A and B (e.g. **Fig. 4, 5**).

The content of the dedicated crops (silage and triticale silage) with which to feed the digesters must therefore be kept below 30%, only in this way all the cases analyzed fall within the *double counting* regime for which each CIC corresponds to 5 Gcal, also guaranteeing economic savings in terms of supply of by-products, cheaper compared to energy crops.

All cases (A+B) shall also provide for:

- Biomethane liquefaction plant in LNG (necessary to guarantee transportation to the users with tank cylinders);

- Upgrading plant with membrane technology;
- A co-generator to cope with the thermal self-consumption (of digesters) and partly with the electric one.

Only for the case type A coverage of a third storage tank is envisaged to make another biodigester.

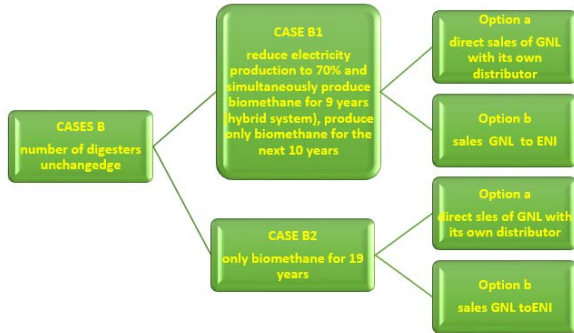

Figure 4: configuration of plant cases B

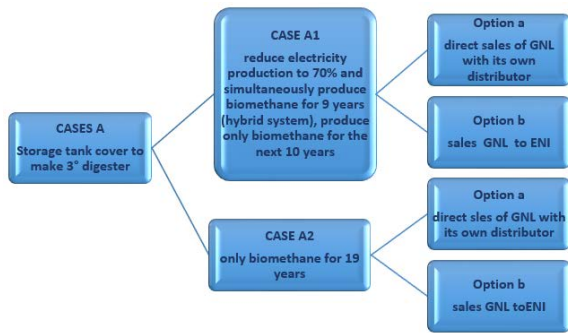

Figure 5: configuration of plant cases A

Therefore, from the yields of each by-product of which the plant can be supplied, the new quantity of biomass by weight necessary to re-enter the double counting has been calculated (e.g. Table V), keeping unchanged the biogas production of the two digesters equal to 4.060.543 Nmc/year [5].

Table V: quantity of biomass in weight recalculated

parameters	LIQUID		SOLID				
	cuttle slurry	fruit	sansa	bread	sweets	corn	triticale
SS[%]	0,8	0,18	0,31	0,65	0,78	0,33	0,33
SV[%]	0,82	0,94	0,95	0,97	0,97	0,93	0,92
Biogas [Nmc/ton SV]	380	480	540	550	793	620	540
CH4 [%]	0,6	0,51	0,65	0,54	0,54	0,53	0,52

Considering that the volume of the two digesters is equal to 5.140 m³ and that, to avoid acidosis phenomena inside the digesters with consequent lack of production, we must have: VOC limit (organic volatile load) Kg SV/mc/d = 4.

According to Table VI we have:

- tons SV/year= 6.468
- tons of biomass /day =39,4

- tons/mc digester/day=0,076
- COV=3,49<4

Table VI: tons of biomasses recalculated

Biomass	tons/year	%
corn	1.000	7
triticale	1.000	7
sansa	1.500	11
fruit	2.800	20
sweets	4.200	30
bread	700	5
cuttle slurry	2.000	14
water	1.000	7

For all cases A covering a storage tank to be converted into a 3rd digester (3.500 m³), the quantities in addition to the previous ones needed to feed the new tank, were calculated using the same criteria (e.g. Table VII), while the percentages for each substrate remained fixed [6].

- tons SV/year= 4.404

Table VII: tons of biomasses calculated for additional digester

Biomass	tons/year	%
corn	681	7
triticale	681	7
sansa	1.021	11
fruit	1.907	20
sweets	2.860	30
bread	477	5
cuttle slurry	1.362	14
water	681	7

The third digester would bring biogas production to 6,843,334 [Nmc] with a 55% biomethane content. With this new supply plan, it is not only possible to enter the CIC double counting system, but also guarantees economic savings in terms of supply of by-products, which are cheaper compared to energy crops.

6 UPGRADING TECHNOLOGIES

6.1 Comparison between different technologies

Currently, different technologies for the biogas upgrading phase are available on the market (e.g. Fig.6).

This phase involves the drying of raw biogas and the removal of carbon dioxide (<2%), and therefore the increase in the calorific value of the produced gas.

It is difficult to compare the different biogas upgrading technologies in a universally valid way as many fundamental parameters depend strongly on the local context; the high performance of a technology to improve the quality of biomethane often does not correspond with the cheaper operation.

Below are the most important parameters of biogas upgrading technologies, applied to a typical raw biogas composition (e.g. Table VIII).

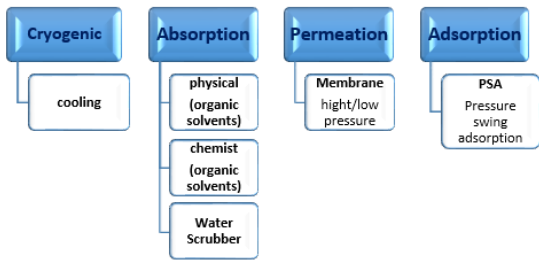

Figure 6: technologies for the biogas upgrading [7]

Table VIII: Comparison between different upgrading technologies [8]

Parametro	Scrubbing ad acqua	Scrubbing fisico con composti organici	scrubbing Amminico	PSA	Tecnologia a membrane
Tipica taglia di impianto [m ³ /h biometano]					
Contenuto tipico di metano [vol%]	95,0-99,0	95,0-99,0	>99,0	95,0-99,0	95,0-99,0
Recupero di metano [%]	98,0	96,0	99,96	98	80-99,5
slip metano [%]	2,0	4,0	0,04	2,0	20-0,5
Tipica pressione di consegna [bar(g)]	4-8	4-8	0	4-7	4-7
Richiesta energia elettrica [kWhel/m ³ biomethane]	0,46	0,49-0,67	0,27	0,46	0,25-0,43
Domanda di calore e livello temperatura	-	medio 70-80°C	alto 120-160°C	-	-
Necessità di desolfurazione	Dipende dal processo	si	si	si	si
Necessità materiali di consumo	Agente antivegetati vo agente essiccante	Solvent organico (non pericolosi)	Soluzioni ammine (pericolose, corrosive)	Carboni attivi (non-pericolosi)	
Campo di carico parziale [%]	50-100	50-100	50-100	85-115	50-105
Numeri di impianti di riferimento	alto	basso	medio	alto	basso
Tipici costi di investimento [€/m ³ /h biometano]					
per 100m ³ /h biometano	10.100	9.500	9.500	10.400	7.300-7.600
Per 250m ³ /h biometano	5.500	5.000	5.000	5.400	4.700-4.900
Per 500m ³ /h biometano	3.500	3.500	3.500	3.700	3.500-3.700
Tipici costi operativi [ct/m ³ biometano]					
per 100m ³ /h biometano	14,0	13,8	14,4	12,8	10,8-15,8
Per 250m ³ /h biometano	10,3	10,2	12,0	10,1	7,7-11,6
Per 500m ³ /h biometano	9,1	9,0	11,2	9,2	6,5-10,1

The investment cost of a biogas upgrading plant depends a lot on its size. In the following graph (e.g. Fig. 7) the investment costs of the various upgrading technologies are compared to the variation of the biogas production capacity, the investment costs for each technology fall within a range corresponding to the thickness of the line since the costs specific to the installation depends on site specifications and extra investment options [9].

As can be seen for high capacity investment costs are the same for all technologies except for membranes that have, in these cases, higher investment costs. For small plants the costs increase, less rapidly for the membranes.

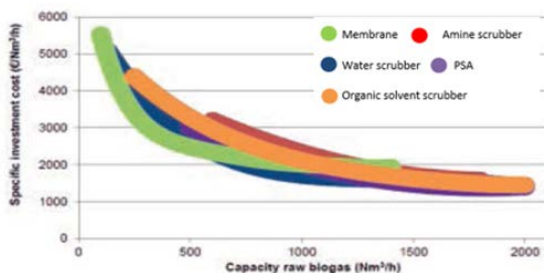

Figure 7: specific investment costs of biogas upgrading technologies according to the size of the plant [10].

6.2 Membrane upgrading technology

The choice of the economically optimal biogas

upgrading technology is strongly conditioned by the quality and quantity of the raw biogas to be treated, the desired biomethane quality and the final use of this gas, the operation of the anaerobic digestion plant and the types and continuity of substrates.

Based on the raw biogas composition, this process includes (e.g. Fig. 8):

- the separation of carbon dioxide with consequent increase in the calorific value;
- the drying of the gas and the removal of trace substances such as oxygen, nitrogen, hydrogen sulphide, ammonia or siloxanes.

This technology, which is based on the different permeability of a gas through a polymer, is the most suitable for small/medium flow rates of biogas, guaranteeing methane recovery up to 99% for multi-stage systems.

The main features of this technology are:

- Quality of the biomethane according to the network code;
- Modular system already supplied compact and functional inside containers;
- High flexibility in the process layout and adaptation to the biogas plant,
- and flexible behavior at partial load and dynamism of the system;
- Low operating costs;
- System integration without changes to the anaerobic digestion portion.
- High performance for small and medium capacity plants.

Biogas needs purification from H₂S, H₂O, NH₃, VOCs, siloxanes and powders before reaching the CO₂ separation stage from CH₄. Although carbon dioxide is a major contaminant in raw biogas during biomethane production, it has been shown that hydrogen sulfide removal can be crucial for the technological and economic feasibility of the upgrading chain because it is dangerous and corrosive [11].

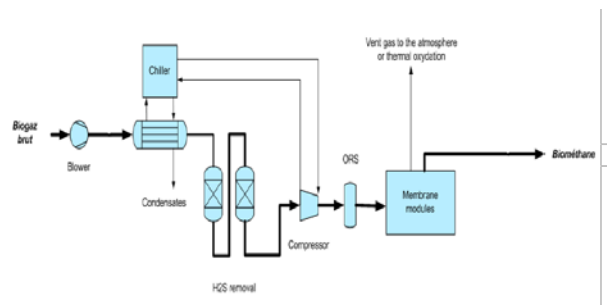

Figure 8: membrane technology process scheme

6.3 Liquefaction technology

The liquefaction technology, which allows the specific volume of gas to be reduced by approximately 600 times compared to standard conditions, allows the storage and transport of considerable amounts of energy in considerably reduced spaces at competitive costs.

LNG is obtained from the liquefaction of biomethane, bringing the latter to a temperature of -160 ° C through cryogenic systems. A cryogenic system, unlike a classic refrigeration cycle, operates at a higher pressure and repeats in a semi-open circuit a process of compression-cooling and expansion a greater number of

times thus allowing the lowering of the temperature up to -195 C ° .

The LNG produced in this way will be stored in cryogenic tanks and then transported by two tankers that will act as a shuttle between the plant and the LNG user.

Since the plant in question is small rather than a SMR (single mixed-refrigerant) technology, which uses a mix of nitrogen and methane as refrigerant, the Brayton-reverse cycle technology has been chosen (e.g. **Fig. 9**) [12].

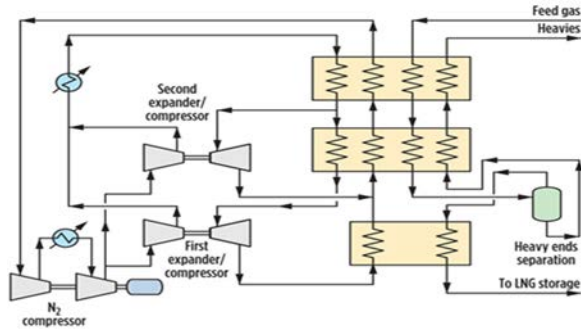

Figure 9: Diagram of Brayton reverse cycle

This is an excellent nitrogen refrigeration cycle which is composed of quasi isentropic processes, compression and expansion, and isobaric processes, heat exchangers.

In the system the nitrogen gas is compressed and expanded in several stages in order to cool it and conduct it through a system of several heat exchangers where the biomethane enters the ambient temperature of 300K and comes out in the form of 100K LNG, intended for a cryogenic tank

The typical investment cost of the technology is $\text{€ } 1,500/\text{ t}$ of product, but can still vary from case to case depending on the plant requirements.

6.4 Co-generation for self-consumption

In the case studies in which the plant produces only biomethane or passes from hybrid to biomethane, in order to make the plant more efficient, it was decided to replace the current co-generator with one of lesser power.

Table IX: co-generator characteristic

	3 digesters	2 digesters
Thermal self-consumption (kWh)	737.000	434.000
Electric self-consumption (kWh)	814.000	479.000
Thermal power required (kW)	93.5	55
Model	S-73 Greenpower	K-33 Bluepower
Thermal power (kW)	114	72
Electric Power (kW)	75	33
Cost (Euro)	150.000	66.000

Two different co-generators were chosen, depending on the case, with a third digester or without, to cope with the different thermal necessity (e.g. Table IX).

The co-generator has been sized on the thermal power necessary for the digesters while the remaining self-consumption electric rate, not produced by the co-generator, is taken from the grid.

7 CALCULATION OF INVESTMENT COSTS

In this section, all costs related to the purchase and installation of the plant components to achieve the upgrading of the plant have been identified and explained (e.g. **Table X**)

Table X: investment costs

COSTS (k€)	Electric Energy		Biomethane		Electric Energy		Biomethane	
	Direct sale (A1a)	Sale to ENI (A1b)	Direct sale (A2a)	Sale to ENI (A2b)	Direct sale (B1a)	Sale to ENI (B1b)	Direct sale (B2a)	Sale to ENI (B2b)
Liquefaction Plant	3.633	3.633	3.633	3.633	2.204	2.204	2.204	2.204
Upgrading N. 2 tank carts	1.523	1.523	1.523	1.523	1.232	1.232	1.232	1.232
New tank cover GNL distributor	100	100	100	100	100	100	100	100
Tests and authorizations	180	180	180	180				
Storage plant	800		800		800		800	
TOT (k€)	6.404	5.606	6.404	5.606	4.505	3.706	4.505	3.706

The new operating costs that the company will have to face each year have been identified (e.g. **Table XI**).

For the determination of personnel costs, the presence of five specialized workers was estimated.

For the purchase cost of the biomass, the costs of corn and triticale were estimated at $\text{€ } 40$ per tons and the supply of by-products at an average price of $\text{€ } 25$ per tons.

Energy costs are due to the electricity consumption of the upgrading and liquefaction technology that they take directly from the grid.

Table XI: operating costs

CASE	Costs for personnel	Supply Costs	Energy costs	Management costs	TOT
	EURO	EURO	EURO	EURO	kEURO
A1a					
Years with hybrid	139.400	603.135	299.271	962.194	2.004
Years biomethane	139.400	603.135	500.691	962.774	2.206
A1b					
Years with hybrid	139.400	603.135	299.271	833.194	1.875
Years biomethane	139.400	603.135	500.691	850.774	2.098
A2a	139.400	603.135	500.691	962.774	2.206
A2b	139.400	603.135	500.691	830.773	2.076
B1a					
Years with hybrid	139.400	410.000	91.119	907.481	1.548
Years biomethane	139.400	410.000	303.729	907.871	1.761
B1b					
Years with hybrid	139.400	410.000	91.119	777.481	1.418
Years biomethane	139.400	410.000	303.729	791.871	1.645
B2a	139.400	410.000	303.729	907.871	1.761
B2b	139.400	410.000	303.729	777.871	1.631

8 PROFITABILITY OF THE PLANT

The biomethane produced is introduced into the transport network will yield an income for each CIC whose value, according to the biomethane DM 2017, will amount to €375 while, the selling price of LNG will be equal to €0.96 / kg in the case of direct sales with own distributor of LNG or equal to 0.85 €/kg if sold to ENI.

In addition, the incentive of the electric kWh produced by the biogas paid with the TO all-inclusive tariff at a fixed price of 0,28 €/kWh remains, while the price that the company ESCOLazio, the plant manager, has stipulated with the local nursery plant for the sale of thermal energy it will pass, in reconverted structure, to 0,4 €/kWh.

Regarding the supply of biomass, the cost of corn and triticale remains unchanged (€10/t) while the by-products on average will have a cost of €25/t.

8.1 Economic indicators

The economic indicators used to assess the profitability of the investment are briefly explained below:

- SPB (Simple Pay-Back): it represents the number of years required, so the investment is recovered and therefore the sum of the cash flows is zero;
- DPB (Discounted Pay-Back): similar to the SPB with the difference that it takes into account the discount rate;
- Discount rate (α): is the interest rate to be used to discount financial capital payable at a certain future date (or in any case a certain future cash flow), so that the discounted capital, ie payable today, is financially equivalent to the capital due at a future date;
- VAN (Net present value): significant index that measures the final result of an investment in terms of discounting;
- IP (Profit Index): returns information on profitability commensurate with the size of the initial investment;
- TIR (Internal rate of profitability): it is the value of "a" for which it is VAN = 0.

8.2 Economic results

All the economic indicators obtained from the analysis have been calculated with a discounting rate $\alpha = 5\%$ (e.g. **Table XII**)

Table XII: economic indicators

CASE	VAN €	IP %	TIR %	SPB years	DPB years
A1a	23.244.596	276	34,4	2,7	3
A1b	21.142.735	277	35,3	2,6	2,9
A2a	22.684.704	274	34,4	2,7	3
A2b	21.348.092	286	34,5	2,8	3,1
B1a	8.547.907	131	20	4,4	5,1
B1b	8.211.872	134	20,8	4,3	5
B2a	7.379.713	115	19,3	4,6	5,6
B2b	7.594.568	143	21,6	4,2	5

From the results obtained we can well understand, as shown in the above graphs (e.g. **Fig. 10, 11, 12**), that the cases in which there is no increase in production through the coverage of a storage tank (case B) are certainly to be discarded compared to the scenario that provides for three digesters. This is justifiable because, despite having to face investment costs for the coverage of the tank the higher costs of supplying the biomass and treatment (upgrading first, liquefaction then) of higher flow rates of biogas, the revenues obtained from the release of CIC and the sale of the LNG goes far beyond the coverage of the costs to be incurred.

Taking into consideration only cases of type A, one can see how the differences in the VAN and the IP are not so substantial as to indicate the best case, but the TIR discourse is very different. The A1b case presents itself as the best one according to TIR which gives us an information on the internal rate of return on the investment.

The hybrid condition guarantees a better profit because there is the possibility in the remaining 9 years of electricity incentive to take advantage, on 30% of biogas production, of the release of CIC for biomethane released for consumption in transport and its sale to ENI, thus avoiding the costs of investment and management of a distribution system.

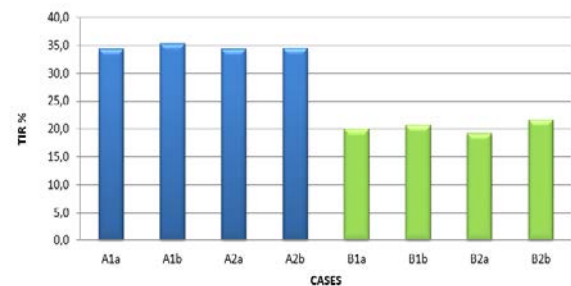

Figure 10: TIR (value %)

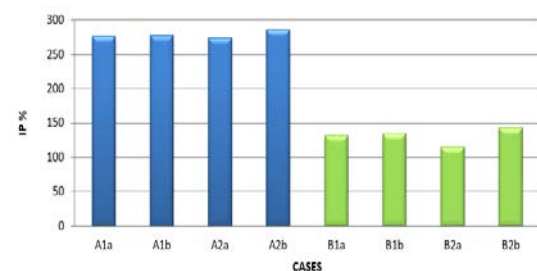

Figure 11: IP (value %)

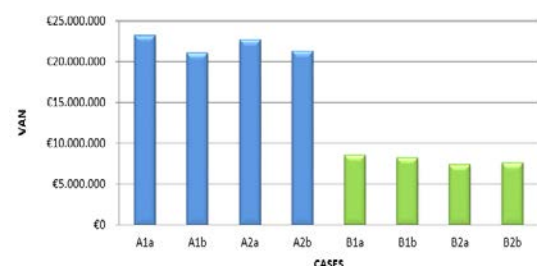

Figure 12: VAN (value Euro)

8.3 Analysis of economic sensitivity

The input prices, as well as the value of the CIC provided by the biomethane DM 2018, are subject to a potentially variable market, therefore a sensitivity analysis has been carried out in order to verify the investment response as the economic conditions proposed change.

Therefore, economic indicators have been recalculated for the A1b case as the following input prices change:

- CIC value of €300 (inside of 375€) ;
- Average price of by-products at €35 / t;
- + 20% GNL sale prices;
- -20% GNL sale prices

Table XIII: economic indicator for A1b case

CASE	VAN €	IP %	TIR %	SPB years	DPB years
Current	21.142.735	277	35,3	2,6	2,9
cost of by- products = 35€/ton	18.867.497	247	32,5	2,8	3,2
CIC=300€	17.314.373	227	31,3	2,9	3,3
Sale of GNL +20%	24.942.157	327	39	2,4	2,6
Sale of GNL -20%	17.343.312	227	31,5	2,9	3,3

From the results obtained (e.g. **Table XIII**) we can conclude that the variability of the cost of the incoming by-product does not significantly affect then in the basic case.

The role of the CIC is very different, the decrease of which determines the worst TIR in which the scenario can be found. This makes it clear how the determination of their CIC value, has a high weight in the biomethane sector given its strong impact on the project economy.

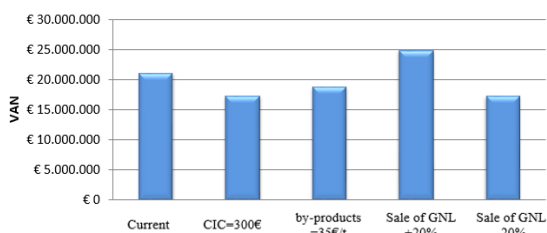

Figure 11: case A1b VAN (Euro)

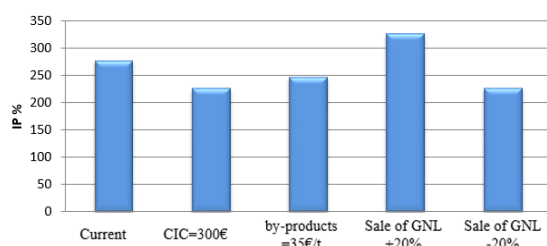

Figure 12: case A1b IP (value %)

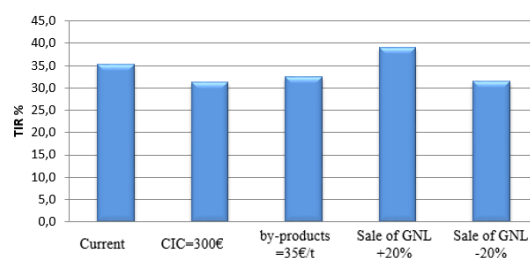

Figure 13: case A1b TIR (value %)

Regarding the price of GNL sales, this can bring the same effects of CIC on the investment if there is a 20% decrease in price, so it can be a big economic contribution if the sale price were to increase by 20%. In the latter case, in fact, the TIR would increase by four percentage points compared to the base case (e.g. **Fig. 13, 14, 15**).

9 CONCLUSIONS

The analysis carried out concluded that an increase in the production of biogas with the addition of a third digester results in much higher revenues than the other cases because both the number of CIC and the sale of LNG weigh on the quantity of biomethane produced.

The high value of the CICs results in high profits, so much so that reconversion projects, like the one that has just been examined, are very interesting.

The choice of the legislator to give CIC high values has depended on the need to reach the European targets on biofuels, a sector where Italy is far behind other EU countries, by doing so, with the current Ministerial Decree of 2 March 2018, the biomethane sector has become more interesting and accessible for plants that intend to make a reconversion to switch from the production of electricity incentivized to the biomethane to be fed into the network.

Indeed, the sensitivity analysis showed that the CIC have a strong impact on the value of the investment as well as the same price of LNG that is in any case subject to a variable market.

10 REFERENCES

- [1] Claudio Fabbri CRPA – Reggio Emilia e Alessandro Ragazzoni Dipartimento di Scienze Agrarie – Università di Bologna “Analisi di alcuni esempi di sostenibilità economica della filiera del biometano”: (Modena 2016)
- [2] M. Negri, J. Bacenetti M. Brambilla, A. Manfredini, A. Cantore, S. Bocchi - Biomethane production from different crop systems of cereals in Northern Italy”: (2013)
- [3] M.C. Annesini, R. Augelletti, I. Fabriani, M. A. Murmura, L. Turchetti - Analisi tecnico-economica del processo di upgrading del biogas mediante Pressure Swing Adsorption:
- [4] D.M del 2nd March 2018 – MISE
- [5] G. Carrosio Energy production from biogas in the Italian countryside : Policies and organizational models” (2013)
- [6] P. Vandevivere, L. De Baere, “Types of anaerobic digesters for solid wastes

- [7] S. Piccinini e C. Fabbri Le tecnologie per la purificazione del biogas: costi e possibilità”
- [8] VIENNA UNIVERSITY OF TECHNOLOGY (AUSTRIA) Dal biogas al Biometano Elaborato”: da Institute of Chemical Engineering
- [9] C.Fabbri, “Principi base e tecnologie dell’upgrading”, Consorzio Italiano Biogas
- [10]F. Bauer, T. Persson, C. Hulteberg, D. Tamm - Biogas upgrading – technology overview, comparison and perspectives for the future: (May 28,2013)
- [11] A. Petersson, A. Wellinger, “Biogas upgrading technologies – developements and innovations”, IEA Bioenergy
- [12]B. Price and M. Mahaley, Black & Veatch, Overland Park, Kansas; and W. Shimer, UOP, Des Plaines, Illinois - Optimize small-scale LNG production with modular SMR technology (2015)