

**Department of Construction Management**

**Total Constraint Management for Improving Construction  
Work Flow in Liquefied Natural Gas Industry**

**Jun Wang**

**This thesis is presented for the Degree of**

**Doctor of Philosophy**

**of**

**Curtin University**

**October 2018**

## DECLARATION

To the best of my knowledge and belief, this thesis contains no materials previously published by any other person except where due acknowledgement has been made.

This thesis contains no materials which have been accepted for the award of any other degree or diploma in any university.

Signature: ..... *Jun Wang* .....  
Date: ..... *12/10/2018* .....

## ACKNOWLEDGEMENTS

I would like to express my gratitude to all those who have helped me complete the thesis. I want to thank my main supervisor, Professor Xiangyu Wang, who encouraged me to start by investigating practical problems in construction management, introduced me to the Woodside company (Australia's most experienced LNG operator and largest independent oil and gas company), gave me wise advice at every step in my research, and encouraged me all along the way.

I have also been extremely fortunate to have Associate Professor Peng Wu as my co-supervisor. He gave me lots of useful and innovative feedbacks throughout my research period. In addition, without his diligent efforts on the improvement of the academic papers, the publication of these papers arising from this research would not have been possible.

I am very grateful as well for the opportunity to work with a group of extraordinary research colleagues (past and present) in the Curtin BIM Centre: Mrs. Wenchi Shou, Mr. Martijn Truijens, Dr. Hung-Lin Chi, Dr. Lei Hou, Dr. Changzhi Wu, Dr. Heap-Yih Chong, Dr. Wen Yi, Dr. Chao Mao, Mr. Jian Chai, and Mr. Do-Yeop Lee. Special thanks also to Associate Professor Rafael Sacks and Professor Glenn Ballard, who offered constructive advice during my research, especially in the Total Constraint Management framework development.

Beyond the ivory tower, field experiment and collaboration with industry are important parts of my research. I would like to thank: Mr. Malcolm Swaddle from the Fremental Steel company and Mr. Greg Guppy from the Australian Centre for Energy and Process Training for providing the field testing places; Mr. Kashif Saleem from Track'EM, Mr. Alastair Mcarthur from RAMP, Mr. Pat Williams from Geoforce for providing tracking and sensing technologies including hardware and software; Mr. Mike Price and Mr. Andy Grosse from Woodside, and Mr. John Florlani from KAEFER for contributing their industry expertise in the field experiment design.

This study would not be possible without the financial support from the Australian Research Council Linkage Program (Grant number LP130100451).

I am indebted to my colleagues and friends in the Department of Construction Management, Curtin University for providing assistance. Finally, never to be forgotten are my warmest family and my dearest wife. I fall short of words to extend the deepest gratitude from my soul to their loves, sacrifices, and moral supports. I wish to proudly dedicate this piece of work to them all.

# TABLE OF CONTENTS

<b>ACKNOWLEDGEMENTS .....</b>	<b>I</b>
<b>TABLE OF CONTENTS .....</b>	<b>II</b>
<b>ABSTRACT .....</b>	<b>VIII</b>
<b>LIST OF FIGURES .....</b>	<b>X</b>
<b>LIST OF TABLES .....</b>	<b>XIII</b>
<b>LIST OF ABBREVIATIONS .....</b>	<b>XIV</b>
<b>LIST OF PUBLICATIONS .....</b>	<b>XVII</b>
<b>Chapter 1: Introduction.....</b>	<b>1</b>
1.1 Introduction.....	1
1.2 Problem Statement .....	5
1.2.1 Deficient process for constraint life cycle management .....	5
1.2.2 Insufficient methods for constraint modelling.....	6
1.2.3 Inefficient methods for cross-domain constraint information sharing .....	7
1.2.4 Inefficient approaches for constraint monitoring.....	8
1.3 Research Aim and Objectives .....	8
1.4 Research Proposition .....	9
1.5 Significance and Contribution of the Research.....	10
1.6 Structure of the Thesis .....	11
<b>Chapter 2: Literature Review.....</b>	<b>14</b>
2.1 Constraint Definition, Classification, and Management .....	14
2.1.1 Constraint definition .....	14

2.1.2 Constraint classification .....	15
2.1.3 Constraint management.....	17
2.2 Constraint Modelling and Analysis .....	20
2.2.1 Current approaches for constraint modelling and analysis.....	21
2.2.2 SNA method.....	25
2.2.3 DNA method .....	26
2.2.4 Summary .....	28
2.3 Cross-domain Constraint Information Sharing .....	29
2.3.1 Current approaches and challenges in constraint information sharing .....	29
2.3.2 Semantic web technology .....	33
2.3.3 ISO 15926 .....	33
2.3.4 Linked data technology .....	35
2.4 Constraint Tracking Technologies .....	36
2.4.1 Barcode, RFID and GPS .....	37
2.4.2 Laser scanning and photogrammetry .....	38
2.4.3 Other tracking technologies.....	39
2.4.4 Summary .....	39
<b>Chapter 3: Research Methodology .....</b>	<b>40</b>
3.1 Research Philosophy.....	40
3.1.1 Paradigm .....	40
3.1.2 Deductive and Inductive Research .....	41
3.1.3 Qualitative and Quantitative Research.....	41
3.2 Research Design.....	42

3.2.1 Focus Group Study .....	43
3.2.2 Experimental Research Method.....	48
3.2.3 Linked Data Development Method.....	56
3.3 Conclusions.....	58
<b>Chapter 4: A Hierarchical Constraint Management Process to Identify and Remove Constraints through Project Life Cycles .....</b>	<b>59</b>
4.1 Introduction.....	59
4.2 Framework of the Hierarchical Constraint Management Process .....	59
4.2.1 Constraint modelling.....	61
4.2.2 Constraint monitoring .....	63
4.2.3 Constraint removal.....	65
4.2.4 Loop 1 (CWA Level).....	65
4.2.5 Loop 2 (CWP Level).....	66
4.2.6 Loop 3 (IWP Level).....	66
4.3 Conclusions.....	67
<b>Chapter 5: DNA for Constraint Modelling and Management in LNG Construction ....</b>	<b>68</b>
5.1 Introduction.....	68
5.2 Meta-network for Constraint Modelling.....	68
5.3 A Framework of DNA for Constraint Management.....	71
5.3.1 Constraint meta-network development .....	72
5.3.2 Constraint monitoring and removal .....	77
5.3.3 Dynamic constraint analysis.....	79
5.4 Validation.....	81

5.4.1 Results.....	85
5.4.2 Limitations .....	87
5.5 Conclusions.....	87
<b>Chapter 6: Improving Cross-domain Constraint Information Sharing in LNG Construction through Linked Data Technology .....</b>	<b>89</b>
6.1 Introduction.....	89
6.2 A Linked Data-enabled Approach for Cross-domain Constraint Information Sharing	89
6.3 Vocabulary & Ontology Selection and Development .....	91
6.4 RDF Data Transformation .....	98
6.4.1 Drawing data to RDF.....	99
6.4.2 Table data to RDF.....	101
6.4.3 Document meta-data to RDF.....	103
6.5 Linked Constraint Data Cloud.....	104
6.5.1 Data interconnection among RDF data sets .....	104
6.5.2 Data interconnection between RDF triples and documents .....	105
6.6 Pilot Case Study .....	105
6.6.1 Data preparation and processing.....	106
6.6.2 Data access and inference .....	108
6.6.3 Linked Data applications.....	109
6.6.4 Evaluations and limitations .....	116
6.7 Conclusions.....	117
<b>Chapter 7: A Coordinated Approach for Supply-chain Constraint Tracking in LNG Industry .....</b>	<b>118</b>
7.1 Introduction.....	118

7.2 Tracking Technologies Selection .....	118
7.3 Framework of A Coordinated Approach for Supply-chain Constraint Tracking in LNG Construction.....	124
7.3.1 Supply-chain constraint tracking for general materials.....	126
7.3.2 Supply-chain constraint tracking for project-specific materials .....	126
7.3.3 Supply-chain constraint control platform.....	127
7.4 Experiments and Results.....	127
7.4.1 Experiment one: offsite fabrication tracking .....	129
7.4.2 Experiment two: site logistics tracking .....	136
7.5 Conclusions.....	145
<b>Chapter 8: TCM Method for Improving Construction Work Flow and Productivity</b>	<b>147</b>
8.1 Introduction.....	147
8.2 Overall Design of the TCM Method.....	147
8.3 Validation of the TCM Method.....	148
8.4 Results and discussions.....	152
8.5 Conclusions.....	155
<b>Chapter 9: Conclusions, Implications, and Future Recommendations .....</b>	<b>157</b>
9.1 Conclusions.....	157
9.1.1 Research findings for Objective 1 .....	158
9.1.2 Research findings for Objective 2 .....	159
9.1.3 Research findings for Objective 3 .....	160
9.1.4 Research findings for Objective 4 .....	161
9.1.5 Research findings for Objective 5 .....	161



9.2 Summary of Theoretical Contributions .....	163
9.3 Practical Implications .....	165
9.4 Recommendations for Future Research .....	166
<b>References .....</b>	<b>168</b>

## **ABSTRACT**

Liquefied Natural Gas (LNG) projects are typically developed by multiple contractors and subcontractors and are reliant on globally available suppliers and service companies. Due to the high complexity of LNG projects and the remote locations of LNG plants, it is difficult to deliver these projects on time and within budget. Reliable construction plans are vital for the effective coordination across an LNG project's design, procurement and construction stages. Constraints from engineering, supply chain and construction site are identified as the main factors affecting the reliability of construction plans. The primary goal of this thesis is to develop a Total Constraint Management (TCM) method to effectively manage these constraints so as to reduce schedule delay and cost overruns. Constraints in this thesis are defined as anything which prevents construction work plans from being successfully executed in the construction field.

Current approaches for constraint management are static and fragmented. A static and fragmented approach may be applicable in the building industry. However, it does not provide satisfactory performance due to the high complexity of LNG projects. Four shortcomings are identified when directly applying conventional approaches, including: (1) constraints which have a long lead time beyond look-ahead plan cannot be efficiently identified and timely removed; (2) interdependencies among constraints are usually neglected because constraints are modelled in a constraint breakdown structure instead of a network structure; (3) constraint information is difficult to be accessed because such information is stored in various systems and managed by multiple stakeholders; and (4) constraint status is not reliable due to the manual updating method and outdated management platform.

This thesis develops a TCM method which includes four modules: (1) an hierarchical constraint management process module, built on the method of Advanced Work Packaging (AWP); (2) a dynamic constraint modelling and analysis module, using the method of Dynamic Network Analysis (DNA); (3) a cross-domain constraint information sharing module, developed through Linked Data Technology (LDT); and (4) a real-time constraint tracking module, through the integration of four tracking technologies (i.e. barcode, passive and active Radio Frequency Identification, and Global Positioning System).

Five experiments were conducted to evaluate the four parts, respectively. Two laboratory experiments were developed based on a LNG lean construction simulation game to test the effectiveness of the proposed TCM method and the DNA-enabled constraint modelling and analysis method, respectively. A pilot case study was conducted to evaluate the efficiency of

the proposed cross-domain constraint information sharing platform. In addition, two field experiments were conducted to validate the proposed constraint tracking system.

Results of the first laboratory experiment had proven the effectiveness of the DNA method in detecting conflicts between construction plans and constraint-removal plans (100% accuracy). The second laboratory experiment indicated a positive effect when implementing TCM method to facilitate LNG construction, including the reduction of project duration (28%), as well as significant productivity improvement in module installation (130%), off-site module manufacturing (97%), major equipment installation (34%), and pipework installation (32%). The findings of the pilot case study showed that the proposed LDT-enabled approach could successfully interlink cross-domain constraint data, extract and visualise a subset of constraint data as required, and infer extra constraint relationships. The last two field experiments validated the efficiency of the proposed constraint tracking system. For instance, the time spent in tracking welding progress was reduced from 3 hours to an average of 20 minutes.

Theoretical and practical implications of this thesis are also provided for LNG operators, design engineers, contractors and suppliers. It is argued that the proposed TCM can enhance the role of constraint management within current pull planning methods in terms of constraint identification, modelling, monitoring and removal. The TCM will also provide four key contributions to practice including (1) a step-by-step guidance for project team to efficiently manage constraints from project planning to the end of commissioning; (2) a constraint visualisation platform for improving transparent communication and coordination among design engineers, suppliers, contractors, subcontractors and clients; (3) an efficient approach for project participants to access constraint data across multiple domains; and (4) a practical implementation guide for using multiple sensing technologies to track constraints in LNG construction.

## LIST OF FIGURES

Figure 1-1: Factors Responsible for Cost Overruns and Delays (EY 2014).....	2
Figure 1-2: Last Planner System (Ballard and Tommelein 2016) .....	6
Figure 1-3: Structure of the Dissertation .....	13
Figure 2-1: Tree-Structure based Constraint Modelling.....	23
Figure 3-1: Research Design .....	43
Figure 3-2: Construction Work Flows of the LNG Construction Simulation Game .....	50
Figure 3-3: Engineering Drawings and Instructions .....	51
Figure 3-4: Materials, Instruments, and Off-site Fabricated Modules .....	52
Figure 3-5: Construction Site of the Game.....	52
Figure 3-6: Linked Data Development Method.....	56
Figure 4-1: A Hierarchical Constraint Management Process .....	60
Figure 4-2: Constraint Classification .....	62
Figure 4-3: A Simple Example of Constraint Relationship Mapping .....	63
Figure 5-1: An Example of Constraint Network in LNG Construction .....	69
Figure 5-2: Framework of DNA for Constraint Management in LNG Construction.....	71
Figure 5-3: An Example of CWP Network .....	73
Figure 5-4: Result after Incorporating Engineering Constraints.....	74
Figure 5-5: Result after Incorporating Supply Chain Constraints.....	75
Figure 5-6: An Example of the Use of $NUC_i$ Measure .....	81
Figure 5-7: LNG Lean Construction Simulation Game .....	82
Figure 5-8a: Global View of the ICMM.....	83
Figure 5-8b: Partial Enlarged View of the ICMM .....	84
Figure 5-9: Detailed Constraint Check for IWP 2.10.....	84
Figure 5-10: Results of Conflicts between the Given Construction Plans and Constraint- Removal plans .....	85
Figure 5-11: Progress of Constraint Removal during the Experiment .....	86

Figure 5-12: Progress of IWP Installation .....	87
Figure 6-1: A Linked Data-enabled Approach for Cross-domain Constraint Information Sharing .....	90
Figure 6-2: Architecture of the ISO 15926 Ontology (ISO15926 2015).....	93
Figure 6-3: A Snippet of the Constraint Ontology .....	96
Figure 6-4: A Snippet of the AWP ontology .....	96
Figure 6-5: The Merged Ontology .....	98
Figure 6-6: A Snippet of the Sample P&ID Drawing .....	99
Figure 6-7(a): A Snippet of the Converted RDF Data Model in RDF/XML Format.....	100
Figure 6-7(b): A Snippet of the Converted RDF Data Model in a Graph Format .....	100
Figure 6-8: Patterns for Mapping and Transformation.....	102
Figure 6-9: A Snippet of the Converted RDF Data Model in RDF/XML Format .....	103
Figure 6-10: Data Interconnection between RDF Triples and Documents .....	105
Figure 6-11: A real LNG Plant Module .....	106
Figure 6-12: A Snippet of the Final Linked Data Cloud in the RDF/XML Format.....	107
Figure 6-13: Example of A “domain_type” Rule .....	108
Figure 6-14(a): SPARQL Query for Searching All of the Site Constraints Related to <i>IWP10001-Piping-SG-108</i> .....	110
Figure 6-14(b): SPARQL Query for Searching All of the Unremoved Constraints Related to the <i>IWP10001-Piping-SG-108</i> .....	110
Figure 6-15(a): Inference Rules for Listing All the Constraints .....	111
Figure 6-15(b): SPARQL Query for Searching All the Constraints Related to the <i>IWP10001-Piping-SG-108</i> .....	111
Figure 6-16 (a): Setup a Remote REST SPARQL Endpoint in the Gephi Semantic Web Import Plugin .....	112
Figure 6-16 (b): Data Visualisation of the <i>IWP10001-Piping-SG-108</i> .....	113
Figure 6-17 (a): SPARQL Query for Searching All the Engineering Constraints Related to the <i>IWP10001-Piping-SG-108</i> .....	114

Figure 6-17 (b): SPARQL Query for Searching Additional Information of the Engineering Constraint of <i>IsometricDrawing-Piping-SG-108</i> .....	115
Figure 6-17 (c): Raw Isometric Drawing .....	115
Figure 6-17 (d): External Reference Data Library .....	116
Figure 7-1: Framework of a Coordinated Approach for Supply-Chain Constraint Tracking in LNG Construction.....	125
Figure 7-2: Architecture of the Proposed Supply-Chain Constraint Control Platform .....	129
Figure 7-3. Location Definition for Fabrication Tracking.....	131
Figure 7-4: Field Implementation Map for Barcoding Technology .....	132
Figure 7-5: Two Locating Methods for Fabrication Tracking .....	133
Figure 7-6: Progress for Each Individual Component and the Overall Project .....	136
Figure 7-7: The Simulated Scenario of Construction Site Logistics in the Oil and Gas Training Facility.....	137
Figure 7-8: The System Architecture of the Installed RFID Reader.....	138
Figure 7-9: Four Fixed RFID Readers around the Dehydration Module .....	138
Figure 7-10: The Attachment of RFID Tags on the Dehydration Module .....	139
Figure 7-11: The Relationship of RSS Distribution between Two Different RFID Tags at the Same Place .....	140
Figure 7-12: Positioning Errors of RFID Tags with Reference Tags Calibration (Static Case) .....	141
Figure 7-13: Tracking Errors of RFID Tags with Reference Tags Calibration (Dynamic Case) .....	142
Figure 7-14: Time Spent on Searching Materials in the Simulated Laydown Area .....	144
Figure 8-1: Overall Design of the TCM Method .....	148
Figure 8-2: Constraint Meta-network.....	150
Figure 8-3: An Example of Design Variations in Civil Foundations .....	151
Figure 8-4: An Example of Defective Module .....	154

## LIST OF TABLES

Table 2-1: Comparison of the current four approaches for constraint modelling and analysis .....	24
Table 2-2: Comparison between SNA and DNA.....	27
Table 3-1: Profile of the Thirteen Industry Experts and Their Contribution .....	46
Table 3-2: The Roles of the People in the LNG Construction Simulation Game .....	53
Table 4-1: An Example of Maturity Index for A Piping EWP .....	64
Table 5-1: Meta-Matrix for Constraint Network .....	70
Table 5-2: An Example of Maturity Index for A Piping EWP .....	78
Table 5-3: Five Measures for the Dynamic Constraint Analysis .....	80
Table 6-1: The Reused Vocabularies or Ontologies and Their Descriptions .....	92
Table 6-2: Work Package Information .....	101
Table 6-3: Supply Chain Constraint Information .....	101
Table 6-4: Relationship between Work Packages and Supply Chain Constraints .....	102
Table 7-1: Tracking Technology Selection for Each Process.....	120
Table 7-2: Comparison of the Barcode, Passive RFID, active RFID and GPS Tags .....	122
Table 7-3: Activities during Fabrication and Their Corresponding Locations and Weights for Progress Calculation .....	130
Table 7-4: Location Change for the Three Components during Fabrication.....	135
Table 7-5: An Overview of the Tests Done for Site Logistic Tracking .....	141
Table 8-1: The Weight of Each Trade for CP Calculation .....	153
Table 8-2: Actual Duration and CP of the Two Groups .....	154
Table 8-3: The Number of the Defective Modules and Productivity Index of the Two Groups .....	155

## LIST OF ABBREVIATIONS

3D CAD	Three-Dimensional Computer-Aided Design
ACEPT	Australian Centre for Energy and Process Training
ANCL <sub>i</sub>	Actual Number of Constraint Links at time i
ANIN <sub>i</sub>	Actual Number of IWP Nodes at time i
API	Application Programming Interface
AWP	Advanced Work Packaging
BIM	Building Information Modelling
BOM	Bill of Materials
CAN	Construction Assignment Network
CCMM	CWP-oriented Constraint Meta-network Model
CII	Construction Industry Institute
CMD	Constraint Meta-network Development
CMN	Change Management Network
COAA	Constructions Owners Association of Alberta
CPM	Critical Path Method
CPN	Construction Precedence Network
CWA	Construction Work Area
CWP	Construction Work Package
DB	Drawing Barcode
DCMI	Dublin Core Metadata Initiative
DNA	Dynamic Network Analysis
ECN	Engineering Constraint Network
EDMS	Electronic Document Management System
EMN	Engineering Management Network
EPC	Engineering Procurement and Construction
EPN	Engineering Precedence Network
EWP	Engineering Work Package
FIWP	Field Installation Work Package
FOAF	Friend-of-a-Friend



GPS	Global Position System
HTML	Hypertext Markup Language
HTTP	Hypertext Transfer Protocol
ICMM	IWP-oriented Constraint Meta-network Model
IDCN/IDIN	In-Degree of CWP/IWP Node
IFC	Industry Foundation Classes
IN	Interdependency Network
IWP	Installation Work Package
LNG	Liquefied Natural Gas
LPS	Last Planner System
$NUC_i$	Number of Unconnected Components at time $i$
ODCN	Out-Degree of Constraint Node
OWL	Web Ontology Language
P&ID	Process and Instrumentation Diagram
PAB	Pre-assembly Barcode
PB	Pallet Barcode
PDF	Portable Document Format
PERT	Program Evaluation and Review Technique
PFD	Process Flow Diagram
$PNCL_i$	Planned Number of Constraint Links at time $i$
$PNIN_i$	Planned Number of IWP Nodes at time $i$
PWP	Procurement Work Package
QA	Quality Assurance
QC	Quality Control
RDF	Resource Description Framework
RDL	Reference Data Library
RFID	Radio Frequency Identification
RSS	Radio Signal Strength
SB	Site Barcode
SCCN	Supply Chain Constraint Network

SCMN	Supply-Chain Management Network
SCN	Site Constraint Network
SCPN	Supply Chain Precedence Network
SDN	Site Demand Network
SKOS	Simple Knowledge Organization System
SMN	Site Management Network
SNA	Social Network Analysis
SPARQL	Simple Protocol and Resource Description Framework Query Language
SPN	Site Precedence Network
SQL	Structured Query Language
TB	Treatment Barcode
TCM	Total Constraint Management
TOC	Theory of Constraints
URI	Uniform Resource Identifier
UWB	Ultra-Wide Bandwidth
$VCR_i$	Variance of Constraint Removal at time $i$
$VIRS_i$	Variance of IWP Released to Site at time $i$
WLAN	Wireless Local Area Network
XML	eXtensive Makeup Language

## LIST OF PUBLICATIONS

### A. Journal Paper (\* Corresponding Author)

1. **Wang, J.\***, Shou, W., Wang, X., & Wu, P. (2016). Developing and evaluating a framework of total constraint management for improving workflow in liquefied natural gas construction. *Construction Management and Economics*, 34(12), 859-874.
2. **Wang, J.**, Wang, X., Shou, W., Chong, H. Y., & Guo, J. (2016). Building information modeling-based integration of MEP layout designs and constructability. *Automation in Construction*, 61, 134-146.
3. Lee, D. Y., Chi, H. L., **Wang, J.**, Wang, X., & Park, C. S. (2016). A linked data system framework for sharing construction defect information using ontologies and BIM environments. *Automation in Construction*, 68, 102-113.
4. **Wang, J.**, Zhang, X., Shou, W., Wang, X., Xu, B., Kim, M. J., & Wu, P. (2015). A BIM-based approach for automated tower crane layout planning. *Automation in Construction*, 59, 168-178.
5. **Wang, J.**, Sun, W., Shou, W., Wang, X., Wu, C., Chong, H. Y., Liu, Y. & Sun, C. (2015). Integrating BIM and LiDAR for real-time construction quality control. *Journal of Intelligent & Robotic Systems*, 79(3-4), 417.
6. Shou, W., **Wang, J.**, Wang, X., & Chong, H. Y. (2015). A comparative review of building information modelling implementation in building and infrastructure industries. *Archives of computational methods in engineering*, 22(2), 291-308.

### B. Book Chapters

1. **Wang, J.**, Chi, H.L., Liu, C., Wang, X. (2016) BIM-Enabled Collaborative Scaffolding Scoping and Design. In: Luo Y. (eds) Cooperative Design, Visualization, and Engineering. CDVE 2016. *Lecture Notes in Computer Science*, vol 9929. Springer, Cham
2. **Wang, J.**, Hou, L., Wang, Y., Wang, X. and Simpson, I. (2015), "Integrating Augmented Reality into BIM for Health Infrastructure Sector" *ASCE monograph Building Information Modeling: Applications and practices in the AEC industry*, in R. Issa (ed.), American Society of Civil Engineer Publisher.

### C. Conference Papers

1. **Wang, J.**, Shou, W., Wu, P. & Wang, X. (2017). Linked Data for Cross-domain Constraint Information Sharing in LNG Construction. In *LC3 2017: Volume I – Proceedings of the Joint Conference on Computing in Construction (JC3)* (pp. 811-818).
2. **Wang, J.**, Shou, W., & Wang, X. (2015). A framework of total constraint management

for improving work flow in liquefied natural gas construction. In *Proceedings of the 31st Annual Association of Researchers in Construction Management Conference, ARCOM 2015* (pp. 803-812).

3. **Wang, J.,** Wang, X., Shou, W., Guo, J., & Hou, L. (2014). Development of BIM Model Fitness Review System for Modelling Quality Control. In *Computing in Civil and Building Engineering (2014)* (pp. 577-584).

# Chapter 1: Introduction

## 1.1 Introduction

Australia has benefited and will continue to benefit significantly from Liquefied Natural Gas (LNG) investments underway (Ellis 2013). The Global Demand Forecast for LNG is 470 million tonnes per annum by 2030, which means more than 200 million tonnes in new capacity will be needed to fulfil the increased demand (Ellis 2013). However, rising costs in Australia means that this country risks pricing itself out of the global LNG market. For instance, current LNG construction in Australian typically costs 2-3 times higher when compared with other countries (Ellis 2013).

Owners and contractors face enormous challenges to complete engineering and construction projects in the LNG industry which are valued at billions of dollars. At the worldwide level, according to the research conducted by EY (2014) (i.e. a total of 365 projects were identified and investigated with a proposed capital investment above US\$ 1 billion in the four industry segments of Upstream, LNG, Pipelines and Refining), cost and schedule overruns were common in all industry segments and regions. Specifically, 64% of the projects were facing cost overruns while 73% of the projects were reporting schedule delays. In addition, For the 205 projects where cost data were available, the current project estimated completion costs were, on average, 59% above the initial estimate (i.e. the cumulative cost of these projects had increased to US\$1.7 trillion from an original estimate of US\$1.2 trillion, representing an incremental cost of US\$500 billion) (EY 2014).

In Australian LNG construction industry, according to the public report published by EnergyQuest and APPEA (2014), every LNG project in Western Australia has suffered different levels of time and cost overruns. For instance, the latest Wheatstone LNG construction project suffers a six-month delay due to the slow schedule of off-site module manufacturing in Malaysia. Table 1-1 summarises details of the cost and time overruns that had been experienced at the seven Australian LNG projects (Ledesma 2014). Most of them have suffered six months to 1 year delays when compared with the initial time estimation. Delays to the Gorgon LNG project are nearly two years which have had a significant impact on the project economics and even put some of the gas sales contracts at risk. The average percentage increase of budget is approximate 24% which is equal to a total of US\$ 42.3 billion cost overruns.

Table 1-1: Australian LNG Projects-Cost Escalation and Time Delays (Ledesma 2014)

LNG Projects	Start Date	Planned Finish Date (First Cargo)	Finish Date (First Cargo)	Planned Budget (US\$ billion)	Budget at June 2017 (US\$ billion)	Percentage Increase of Budget
Gorgon	2009/09	2014	2016/03	37.0	54.0	46%
Wheatstone	2011/09	2016	2017/10	26.4	29.7	13%
Prelude	2011/05	Early 2017	2018	12.0	13.6	13%
Ichthys	2012/01	2017	2018	34.0	44.0	29%
QCLNG	2010/10	2014	2015	15.0	20.4	36%
GLNG	2011/01	Early 2015	2015/10	16.0	18.5	16%
APLNG	2011/07	2015	2016	20.0	22.5	13%

Managing these LNG projects is challenging as they become increasingly complex and technologically demanding. Previous research suggested that non-technical issues, such as project inadequate planning, ineffective project management, poor contractor management, and poor procurement control, were responsible for the majority of the overruns (EY 2014). Figure 1-1 illustrates the key non-technical internal and external factors commonly behind project delays or overspend. 65% of project failures were due to project development and delivery aspects such as inadequate planning and ineffective project management; A further 21% were caused by poor portfolio management and contracting and procurement strategies, with the remaining 14% of the failures due to external factors such as regulatory challenges and geopolitical challenges (EY 2014).

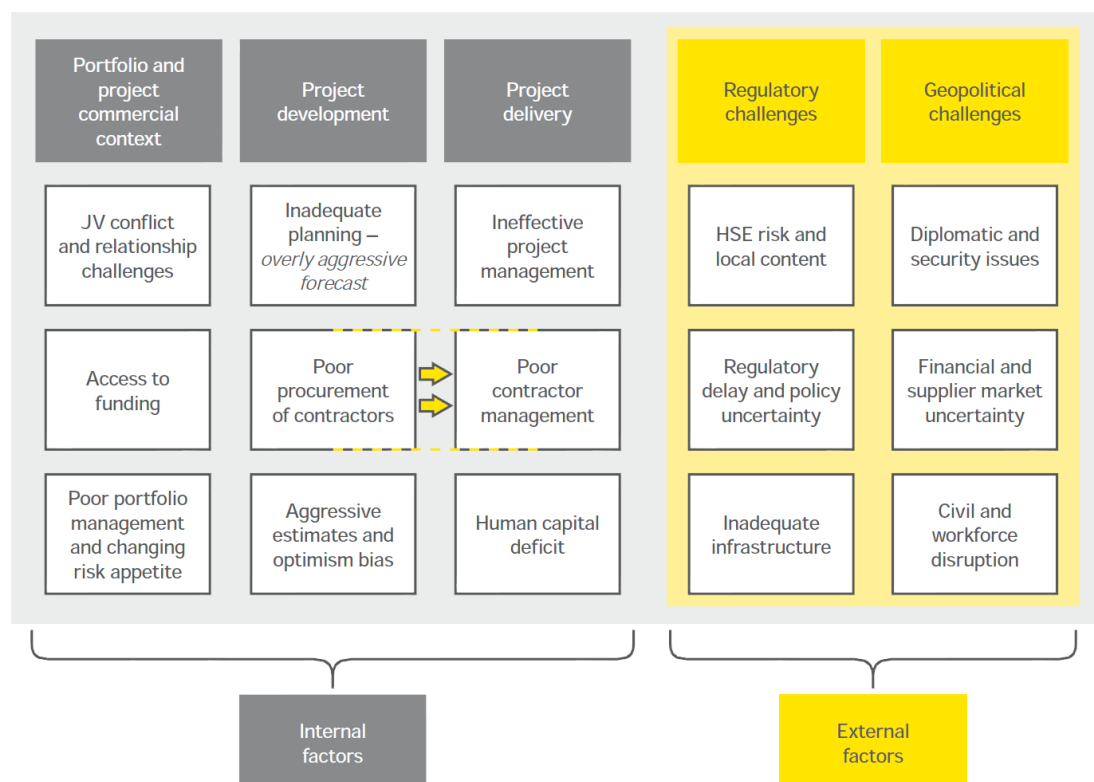

Figure 1-1: Factors Responsible for Cost Overruns and Delays (EY 2014)

Project management team needs to serve remote construction sites, manage multiple engineering teams and global supply chain, solve environmental and permitting issues, and coordinate multiple owners with different specifications and contracting strategies. Time is another essential factor of LNG projects, which usually take about ten years from the planning phase to the delivery of the first cargo. During project execution, various types of work are often conducted simultaneously. Reliable construction plans are therefore vital for the effective coordination across a project's design, procurement and construction stages.

“Pull-driven” method has been proven as an efficient way to improve planning reliability (Tommelein 1998; Ballard 2000; Hamzeh et al. 2015; Dave et al 2016). Compared with the traditional “Push-driven” approach, the main objective of a “Pull-driven” method is to produce finished products as optimally as possible in terms of quality, time, and cost, so as to satisfy customer demand (Tommelein 1998). To implement a pull-driven approach, selective control is needed and should be driven by information about resources in the queues, and work-in-progress and downstream resources (successor queues and activities) in the process (Tommelein 1998). A number of planning methods have been developed to transform the pull concept into the construction industry. The most famous one is the Last Planner System (LPS) developed by Glenn Ballard and Greg Howell, which is a production planning system designed to produce predictable work flow and rapid learning in programming, design, construction and commissioning of projects (Ballard 2000). The second most one, WorkFace Planning (WFP) developed by the Construction Owners Association of Alberta (COAA), is the process of organising and delivering all elements necessary before work is started, to enable craft persons to perform quality work in a safe, effective and efficient manner (Slootman 2007). The third widely utilised one is the Advanced Work Packaging (AWP) developed by a joint venture between the Construction Industry Institute (CII) and the COAA, which aims to align engineering, procurement and fabrication with the sequencing needs of site installation and turnover to operations (Hamdi 2013). Other pull planning methods such as Integrated Production Scheduler developed by Chua et al. (2013) and Integrated Decision Support System developed by Sriprasert and Dawood (2003) are also perform very well in improving planning reliability and project performance, however, they are not widely applied in industrial cases.

Constraint management is one of the key processes within these planning methods (e.g. LPS, WFP, and AWP) to improve construction work flow. They all require that a work package/task cannot be released to the construction site until all related constraints are removed. The concept of constraint was firstly introduced in 1984 as constraint management and the theory of constraints (Goldratt and Cox 1984). It is defined as any condition, such as technical sequencing, temporal/spatial limitations and safety/quality concerns, which prevent work

plans assigned to construction crews from being successfully executed in the field (Blackmon et al. 2011). While the most common types of constraints, e.g. time constraint, can be managed using the traditional project control techniques, e.g. the Critical Path Method (CPM), it is proven that these techniques are not adequate for effectively identifying and tracking detailed constraints in construction works (Pultar 1990). For example, Pultar (1990) argued that CPM does not cover the full spectrum of constraint types and can only be created following the development of a fixed plan. In addition, Zhou et al. (2013) concluded that most of the current mathematical methods developed for construction scheduling are focused on modelling time, cost, and resource constraints. Other key constraints such as quality, work space, and safety are often neglected.

Constraints in this thesis are defined as anything which prevents work packages being successfully executed in the field. According to Wang et al. (2016), constraints in LNG construction can be classified into three main categories: (1) engineering constraints, (2) supply chain constraints, and (3) site constraints. Constraints such as incomplete drawings, lack of assembly specifications, and incomplete 3D models are related to engineering constraints, which affect the start time of procurement, fabrication and site installation. Supply chain constraints include late procurement and delivery of bulk materials and project-specific instruments and equipment. Without timely purchasing and delivering these resources to the site, detailed construction activities cannot be planned and executed. Site constraints contain the shortage of workforce, lack of temporary structures, limited work space, uncompleted preceding works, bad weather, lack of work permits and safety issues. If these site constraints are not timely removed, construction work crews cannot perform their daily tasks.

The difference between a constraint and a risk is that a constraint is something that will happen while a risk is something that may happen (Wang et al. 2016). For example, the likelihood of rain in construction is usually a factor that needs to be considered. In Dubai, this is a risk because it rarely rains but may happen. However, in Melbourne, this is a constraint because it will always rain, especially in winter, and meteorological records provide a very good indication of the likelihood of rainfall on a month by month basis, allowing project managers to make an appropriate action to reduce the impact (Wang et al. 2016). If a constraint is not timely removed, it becomes an issue which needs to be resolved for the project to move forward.



## **1.2 Problem Statement**

LNG projects are becoming increasingly complex and technologically demanding. More than thousands of constraints including engineering constraints, supply-chain constraints, and site constraints will be involved in a project. Moreover, constraints in LNG projects are multi-tiered which means that a given constraint can be exploded into multiple sub-constraints which in turn constrain other constraints and activities. Therefore, it is hard to use conventional tree structure-based constraint modelling method to present these constraints. Other methods such as mathematical model-based and/or simulation-based approaches can handle such complicated constraint relationships, however, very limited constraint types can be considered and modelled using these methods because most of them only concern time, cost and resource constraints. Detailed problems in terms of constraint identification, modelling, monitoring, and removal in LNG construction are summarised into the following four aspects:

### **1.2.1 Deficient process for constraint life cycle management**

Traditionally, shielding assignments are the main approach to improving work flow (Jang 2008). The process of constraint management within current pull planning methods is passive and always late implemented (Jang 2008; Hamzeh 2009). Figure 1-2 illustrates a typical process of the LPS. The actions of constraint identification and removal are conducted during the phase of “Make-Ready Planning (i.e. Look-ahead planning)”. Therefore, constraints which have a long lead time beyond look-ahead plan cannot be efficiently identified and timely removed (Hamzeh et al. 2008; Wang et al. 2016). Although extending the look-ahead window offers a possibility to solve this issue, extending too far in advance can decrease the ability to control onsite workflow (Jang 2008).

In addition, the current process of constraint management only contains basic steps of constraint identification and removal (as shown in Figure 1-2). The process is acceptable in small building projects, however, in an LNG construction project, the implementation of the process becomes difficult due to the large number of constraints involved (Wang et al. 2016). There is a need to develop detailed processes for guiding the constraint removal in a complex environment (Blackmon et al. 2011), by addressing questions such as which constraint should be removed at which time, who is responsible for removing the constraint, and what are the preceding constraints?

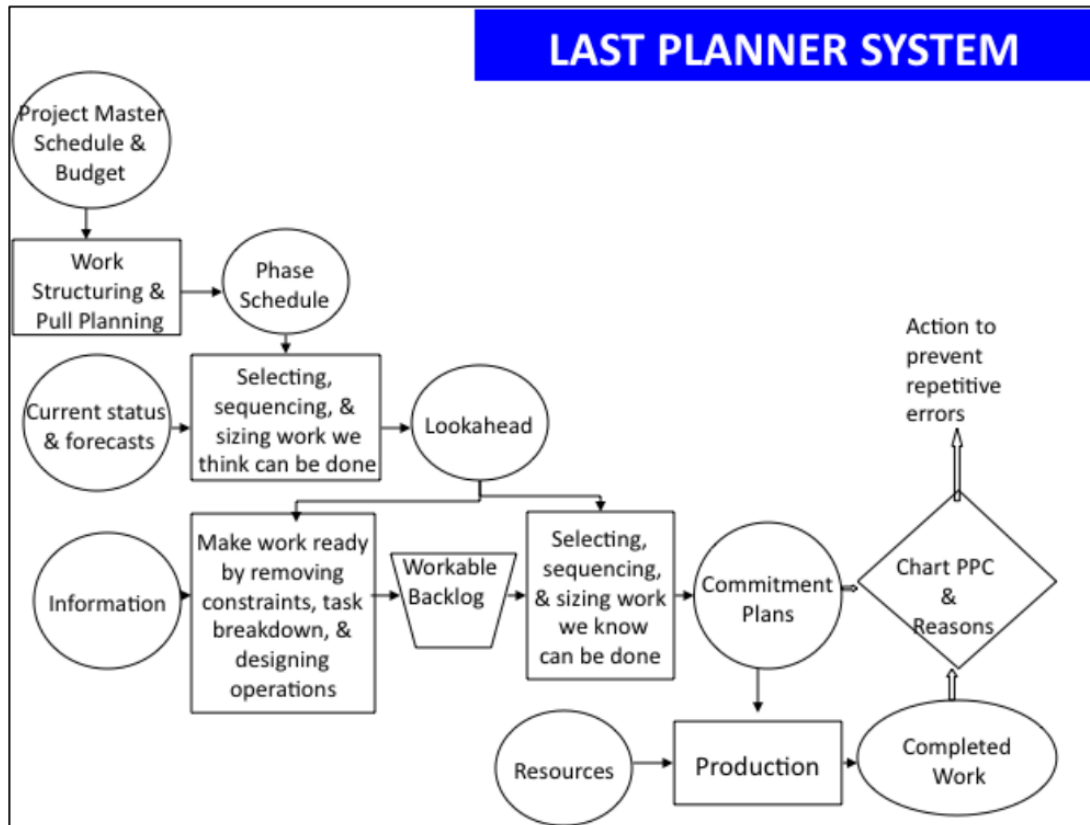

Figure 1-2: Last Planner System (Ballard and Tommelein 2016)

### 1.2.2 Insufficient methods for constraint modelling

Within the conventional planning methods (e.g. CPM), constraints are always considered in a mathematical model which is used to generate an optimised project schedule. As projects are unique in nature, mathematical models for project scheduling and optimisation should consider an array of constraints such as technological and organisational constraints, as well as the availability of resource including labour, equipment, material and information (Jaśkowski and Sobotka 2006, Zhou et al. 2013). However, most of the previous studies can only focus on modelling precedence and/or resource constraints (Zhou et al. 2013). For instance, Al Haj and El-Sayegh (2015) proposed a nonlinear-integer programming model for project planning by taking into account the constraints of time and cost. Resource constraints such as materials were considered by Zoraghi et al. (2017) in their proposed mathematical model. Currently, it is impossible to develop a mathematical model that can cover all kinds of other constraints such as safety, work space, and permit (Zhou et al. 2013).

Within the pull planning methods (e.g. LPS), there is not a pre-defined mathematical method for constraint modelling. Constraint identification and modelling are performed manually during the look-ahead planning stage (Hamzeh et al. 2015). Spreadsheet is one of the most popular tools to identify all constraints for each individual construction activity (Nieto-Morote

and Ruz-Vila 2011, Fernandez-Solis et al. 2012, O. AlSehaimi et al. 2014). Most of the constraint types within the pull planning methods can be considered, however, the interrelationships among constraints are often ignored (Ballard 2000; Hamzeh 2009).

In summary, existing approaches of constraint modelling are either mathematical-driven or human-driven. The former one does not have the capability of modelling all the types of constraints, while the latter one cannot efficiently investigate the interrelationships among constraints.

### **1.2.3 Inefficient methods for cross-domain constraint information sharing**

In current LNG construction practice worldwide, meeting- and paper-based approaches are still widely used for sharing project constraint information, such as constraints of materials, labours, tools, work spaces, safety, and predecessor works (Liston et al. 2003). The main advantage of these approaches is ease of implementation, however, a number of drawbacks need to be highlighted. For instance, project participants, who are involved in either meetings or paper-based reporting processes, spend most of their time trying to understand the project information rather than using the information to address “What-If” questions.

Internet/Web-based approaches provide a convenient and inexpensive approach for constraint information sharing, however, unstructured information is the main concern faced by project stakeholders when searching a specific piece of data (Huesemann 2006, Tsai et al. 2006, Forcada et al. 2010). Search results are limited by search conditions such as keywords, full texts and the use of natural language (Forcada et al. 2010).

Building Information Modelling (BIM) is emerging as a new method for project constraint information sharing (Eastman et al. 2011). Ideally, all the constraint information can be linked or integrated into a central BIM platform. However, in practice, project stakeholders prefer to use their own applications to perform their works (Curry et al. 2013; Dave et al. 2016). Therefore, the constraint data will be stored in various isolated data sources, which use different, usually not aligned, vocabularies and schemes (Curry et al. 2013). It is difficult to build an integrated platform on top of various applications for constraint information sharing due to the absence of long-term relationships among project stakeholders in a construction project (Karan and Irizarry 2015; Dave et al. 2016).

A detailed review of the above three approaches including advantages and disadvantages are discussed in Section 2.3.1. In summary, these three approaches are inefficient in dealing with cross-domain constraint information sharing in a mega project (i.e. LNG construction).

### 1.2.4 Inefficient approaches for constraint monitoring

One of the key functions of LPS is the “Make Ready” process that is responsible for constraint monitoring and removal. However, in practice, it is the most difficult part to be implemented due to the lack of tools to automatically track and update constraint statuses (Dave et al. 2016).

Regular meetings and daily/weekly reports are the most common approaches utilised for constraint monitoring and status updating in current LNG industry (Wang et al. 2016). Both are error-prone processes due to the manual data inputs from humans. A number of emerging tracking technologies, such as Radio Frequency Identification and laser scanning, have been widely investigated to automate the process of constraint monitoring (Lee et al. 2013; Chae and Yoshida 2010; and Wang et al. 2014). However, the adoption rate in practice is still very low especially in LNG industry due to the high implementation cost and technical limitations of each technology (Hou et al. 2014; Chi et al. 2015; and Wang et al. 2016). There is a need to develop a cost-effective solution for constraint monitoring in LNG construction by integrating various tracking technologies. Through technology integration, the advantages of each technology can be amplified while the drawbacks will be minimised.

## 1.3 Research Aim and Objectives

In order to tackle the four problems summarised in Section 1.2, this thesis aims to develop and validate a Total Constraint Management (TCM) method to improve plan reliability and work productivity in LNG construction. To achieve this aim, five objectives are established as follows:

**Objective 1:** To develop a hierarchical constraint management process to identify and remove constraints through project life cycles.

A hierarchical constraint management process will be developed through literature review and focus group studies. In addition, how to align this process to the project’s different stages (i.e. preliminary planning, detailed engineering, construction, and commissioning) will be also discussed.

**Objective 2:** To develop a network-based method for constraint modelling and analysis.

A novel method for constraint modelling and analysis will be developed using Dynamic Network Analysis (DNA) technique. Unlike traditional social network analysis, DNA can handle large, dynamic, multi-mode, multi-link, and multi-level networks with varied levels of uncertainty. A constraint meta-network will be defined including its meta-matrix and development process. Indicators or measurements for analysing the constraint meta-network,

e.g. indicators for identifying the most critical constraint within a given time window, will be also developed

**Objective 3:** To develop a semantic approach for cross-domain constraint information sharing.

A semantic approach for cross-domain constraint information sharing by leveraging Linked Data technology will be developed. Linked data principles enable data to be delivered in both machine- and human-readable formats. Making constraint data on the Web enables greater transparency and accountability, and helps project participants to access required information more efficiently. Within the proposed semantic approach, two new ontologies will be developed for transforming project scheduling data and constraint data into Linked Data Format, respectively. A merged ontology will be also proposed to interlink data from various sources. The prototype of this semantic approach will also be developed and tested in a pilot case study.

**Objective 4:** To investigate current tracking technologies for real-time constraint monitoring and removal.

The performance of four types of contemporary tracking technologies (i.e. Barcode, Radio frequency identification, Global positioning system, and Ultra-wide bandwidth) in constraint tracking will be investigated and evaluated. A coordinated approach for constraint tracking will be also developed to demonstrate its capabilities in tracking automation and productivity improvement.

**Objective 5:** To develop a TCM method based on the research outcomes from Objective 1-4.

A novel life cycle constraint management method, namely TCM, will be developed to improve plan reliability and work productivity in LNG construction. There are four main modules within the TCM: (1) A hierarchical constraint management process module (i.e. Objective 1); (2) A DNA-based constraint modelling and analysis module (i.e. Objective 2); (3) A linked data-enabled cross-domain constraint information sharing module (i.e. Objective 3); and (4) A sensor-based constraint monitoring module (i.e. Objective 4). A laboratory experiment will be developed to validate the effectiveness and efficiency of the proposed TCM method.

## **1.4 Research Proposition**

The main research proposition for this thesis is that “*The proposed TCM method can perform better in constraint identification, modelling, monitoring, and removal, and thus, can significantly improve construction productivity*”. The research proposition was initially developed from peer discussions with supervisors and industry experts in constraint management. Subsequently, it was further informed by the literature review and the

laboratory-based experiments at the early stages of the research project. In the forthcoming Chapters, a combination of qualitative (i.e. focus group studies) and quantitative methods (i.e. laboratory experiments and field experiments) will be conducted to confirm or reject this proposition and then to form necessary conclusions.

### **1.5 Significance and Contribution of the Research**

It is widely recognised that current practices in the Australian LNG industry are far from optimal. This problem urgently calls for an effective solution to mitigate the significant cost and schedule overruns common in resource projects, particularly in mega-projects. If unresolved, the Australian LNG industry will lose its competitive edge compared with cheaper overseas projects. For example, Woodside's recent Pluto Foundation project delivered 15,000 local jobs and contributed some \$7 billion Australian dollars to the local economy. The technology and knowledge from this thesis can be transferred to other sectors to address similar performance and productivity issues in areas including, but not limited to, health infrastructure, railways, and building. Depending on the detailed needs and nature of each industrial sector, the TCM method can be customised to adapt to the dynamic needs of solving a particular problem in each industry. There is exponential growth in the construction of oil and gas facilities and infrastructure. The TCM method will have a profound effect on the work practices of contractors, subcontractors, and suppliers of the entire workforce in Australia, who will benefit from the system while working on mega-projects. Detailed contribution of the research is explained as follows:

Firstly, the proposed TCM method for improving the construction work flow in the LNG industry (*Objective 1&5*) is considered as the major contribution of this study. Currently, the pull planning methods have attracted significant attention in LNG construction projects. Project stakeholders are aware of the importance of constraint management when applying the pull planning method. However, few of them have a clear understanding of how to perform constraint management efficiently. According to Blackmon et al. (2011), it is necessary to develop a TCM framework for thorough identification, classification, tracking, analysis, and removal of all constraints in real world projects.

Secondly, extending the application of the DNA method to model constraints and their interrelationships (*Objective 2*) is also of significance. Current approaches of constraint modelling are either mathematic-driven or human-driven. The former one does not have the capability of modelling all the types of constraints (Zhou et al. 2013), while the latter one cannot efficiently present the interrelationships between constraints (Hamzeh 2009; Hamezh et al. 2015). The DNA method provides a promising way to understand the complex

interactions in a constraint network (Carley et al. 2007). Equipped with time-dimensional analysis and complex modelling capabilities, DNA can efficiently detect conflicts between construction plans and constraint-removal plans, and dynamically identify critical constraints before and during project execution.

Thirdly, the linked data-enabled approach developed in this study for improving cross-domain constraint information sharing (*Objective 3*) is useful to accelerate the realisation of the Linked Open Data concept in LNG projects. Current methods, such as schema-based or service-based approaches, for integrating information from different sources are still time-consuming and very costly (Kang and Hong 2015). The reason is that project data is locked up in certain applications, and managed by multiple stakeholders from different domains. The idea of Linked Open Data has been recognised as the mainstream to solve this problem. With the help of Linked Open Data sets, it is possible to provide the project team with a comprehensive and up-to-date overview on project status. Instead of updating project information manually, it is directly linked to data providers' database, so any updates are reflected immediately (Bauer and Kaltenböck 2011).

Finally, by introducing a number of sensing technologies, industry people could have a better understanding of their advantages and disadvantages, which is useful for them to make an optimal decision when conducting real-time constraint tracking. In addition, a coordinated approach for supply-chain constraint tracking (*Objective 4*) has been developed and tested. The detailed development process can provide a step-by-step guidance for decision-makers in future LNG construction projects.

## 1.6 Structure of the Thesis

This thesis is formulated into nine chapters in the following sequence, as shown in Figure 1-3. Each of them is described as follows:

**Chapter 1** is an introductory chapter which provides the background of this research. Followed by a statement of problems, the aim and objectives of this research are presented accordingly. This chapter also highlights the research significance and contribution.

**Chapter 2** presents a review of the literature in the field of constraint management including constraint modelling, constraint information sharing, and constraint tracking. It contains four sections which correspond to the four objectives developed in Chapter 1.

**Chapter 3** examines the research methodology adopted in this thesis. It first outlines the research philosophy that underpins the approach taken with the research. Then, the rationale for the research design, and the reasons for the adoption of the *Focus Group Study* and

*Experimental Research Method* are discussed. Finally, an overview of the data collection methods used for the thesis, as well as the methods used to analyse the data are explained.

**Chapter 4** proposes a hierarchical constraint management process, which consists of three levels of loops: Loop 1 aims to identify and monitor long lead-time constraints and align engineering and procurement plans to the construction plan; Loop 2 aims to manage constraints from a construction-centred perspective, and continually involve owner, engineers, purchasers and contractors to find new constraints and detect potential constraint-removal issues; and Loop 3 is to maintain, monitor and remove constraints from an installation-centred perspective.

**Chapter 5** develops a Dynamic Network Analysis-enabled method for modelling constraints in LNG construction. A laboratory-based experiment is conducted to demonstrate and evaluate the proposed method.

**Chapter 6** develops a semantic approach for cross-domain constraint information sharing by using linked data technology. A pilot case study is performed to illustrate the feasibility and effectiveness of the proposed approach.

**Chapter 7** proposes a framework of a coordinated approach towards supply-chain constraint tracking in LNG construction that integrates different tracking technologies. Two experiments are conducted in the field to evaluate the feasibility of the proposed approach.

**Chapter 8** proposes a TCM method based on the research outcomes from Chapter 4-7. The proposed TCM method includes: (1) A hierarchical constraint management process module (i.e. Chapter 4); (2) A DNA-based constraint modelling and analysis module (i.e. Chapter 5); (3) A linked data-enabled cross-domain constraint information sharing module (i.e. Chapter 6); and (4) A sensor-based constraint monitoring module (i.e. Chapter 7). A laboratory experiment is developed to validate its effectiveness and efficiency.

**Chapter 9** explains the internal and external validation for this research, its contributions and practical implications. Recommendations for future research are also provided in this chapter.



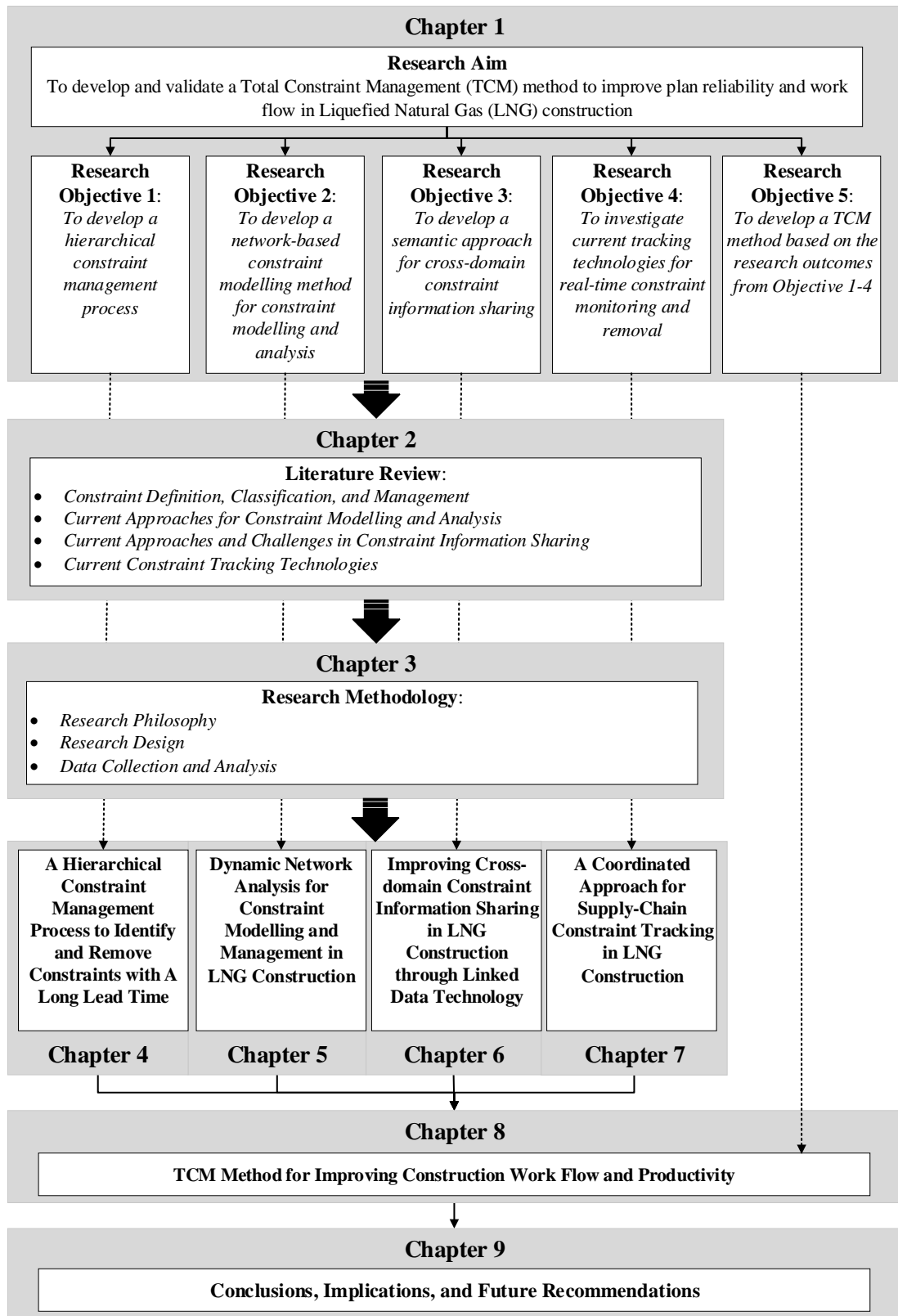

Figure 1-3: Structure of the Dissertation

## Chapter 2: Literature Review

The purpose of Chapter 2 is to review and summarise current works related to the field of constraint management including constraint modelling, constraint information sharing, and constraint monitoring.

### 2.1 Constraint Definition, Classification, and Management

In this section, the definitions of constraints are introduced, followed by discussing a number of existing constraint classifications and reviewing the current practice of constraint management.

#### 2.1.1 Constraint definition

The definitions of constraints vary in different domains. A constraint can be:

- A condition of an optimisation problem that the solution must satisfy in Mathematics (Zhou et al. 2013);
- A demarcation of geometrical characteristics between two or more entities or solid modelling bodies in Computer Science (Wikipedia 2018);
- The degree of statistical dependence between or among variables in Information Theory (Wikipedia 2018);
- A relation between coordinates and momenta in Classical Mechanics (Wikipedia 2018);
- A factor which make populations resistant to evolutionary change in Biology (Wikipedia 2018); or
- Anything that prevents the system from achieving its goal in Business Management (Goldratt and Cox, 1984).

The concept of constraint in this thesis is derived from the lean construction domain. Currently, there are three types of definitions used to describe a constraint, that correspond to the three pull planning method (i.e. LPS, WFP, and AWP), respectively. For instance, In LPS, a constraint is “anything that stands in the way of a task being executable or sound” (LCI 2007). In WFP, constraints are a list of things that a foreman will need to execute a field work order (Slootman 2007). In AWP, constraints are defined as any prerequisite items that prevent and/or delay the successful execution of the work (CII 2013). In this thesis, based on the three previous definitions, constraints are defined as anything that prevents work packages being successfully executed in the construction field.

### 2.1.2 Constraint classification

Constraint classification is a prerequisite work for carrying out constraint identification, modelling, tracking, and removal. In different domains, the classification systems are various. For instance, in Mathematics, constraints can be classified as either absolutely strong redundant, relatively strongly redundant, absolutely weakly redundant, relatively weakly redundant, or necessary (Boneh et al. 1992); in Mechanics, constraints are classified into two types: Pre-constraint and Post-constraint (Höhn 2014). The former one restricts the pre-image of the Hamiltonian time evolution map and correspond to conditions on the canonical data which must be satisfied before an evolution move can be carried out. The latter one, on the other hand, restricts the image of the Hamiltonian time evolution map and must be satisfied after an evolution move is performed (Höhn 2014). In the following paragraphs, constraint classifications that had been developed within the project and/or production management domains are the main focus of this thesis, and had been critically reviewed.

McMullen (1998) categorised the constraints into two groups in terms of their impact: less-impact constraints and higher-impact constraints. The latter ones are also called core problems or root causes. In each project, there are a number of less-impact constraints but only a few higher-impact constraints. Project managers should more focus on identifying and acting on the higher impact constraints. According to Goldratt (1990), there are two basic types of constraints: physical constraints and non-physical constraints. A physical constraint is something like the physical capacity of a machine, in other words, it is something that is rigid and in its current state has a limit on its ability or throughput (e.g. materials, machines, people, demand level). A non-physical constraint can be further classified into three types: (1) Policy constraints that include company procedures, union contracts, and government regulations; (2) Paradigm constraints such as deeply engrained beliefs or habits; and (3) Market constraints that occurred when production capacity exceeds sales.

Constraints are also be categorised into internal constraints and external constraints (Goldratt and Cox 1984). The former ones are inside a system and more under control while the latter ones are outside the system and hard to control. Internal constraints can be eliminated through actions such as assigning more resources (Goldratt and Cox 1984). However, continuing such an action will in turn bring to a point where capacity exceeds demand and constraint exists in another form (Goldratt and Cox 1984). External constraints are hard to be eliminated. Actions taken can merely minimise the effect of undesirable consequence rather than breaking the constraints (Goldratt and Cox 1984).

Lau and Kong (2006) proposed a constraint classification system for managing and controlling constraints in construction working environment. Constraints are classified into five categories

based on a comprehensive literature review and 30 questionnaires: (1) Economic constraints which mainly happened with budget limitation; (2) Legal constraints which mainly related to laws, regulations and standards; (3) Environment constraints which include air protection, tree preservation, traffic limitation, and noise control; (4) Technical constraints which arise from restrictive site areas and congested surroundings; and (5) Social constraints which can appear in three different forms: human resistance, emotional constraints and ownership of the problem.

In LPS, constraints are classified into eight types: information, previous work, human resources, space, material, equipment, external conditions, and funds (Ballard 2000, Koskela 2000). Choo et al. (1999) defined six types of constraints, namely, constraints on contract, engineering, material, labour, equipment, and prerequisite work. Chua and Shen (2005) classified construction constraints into three types: (1) Precedence constraints that determine the start/finish time and the sequences of activities and tasks; (2) Resource constraints which include procurement, materials, manpower, and equipment; and (3) Information constraints that represent the availability of information required for executing construction tasks, such as shop drawings, specifications, and design approvals. Similarly, Sriprasert and Dawood (2003) categorised constraints into four major groups: (1) Physical constraints including technological dependency, space, safety, and environment; (2) Contract constraints including time, cost, quality, and special agreement; (3) Resource constraints including availability, continuity, capacity, and perfection; and (4) Information constraints including availability and perfection (e.g. accuracy, clarity, and relevancy).

It should be noticed that these classifications are developed informally, and none of them has been widely used as a standard in current industry practice. These classifications may not include all constraint types. For instance, the weather and permit constraints are not considered in the classifications developed by Choo et al. (1999), Chua and Shen (2005) and Sriprasert and Dawood (2003). In addition, the hierarchy of the existing classifications is not well defined. For instance, the constraint classification developed by Ballard (2000) or Koskela (2000) is characterised as an aggregation of a number of different types of constraint (i.g. information, previous work, human resources, space, material, equipment, external conditions, and funds). a hierarchical structure of these constraints is not presented within the classification. For other classifications mentioned above, although constraints are classified into three or four categories, the definition of each category is not clear. For instance, the category of information constraints developed by Sriprasert and Dawood (2003) is very abstract and its definition (i.e. information constraints includes availability and perfection) is too vague to guide practical implementation. Therefore, there is a need to develop a new constraint classification for LNG construction projects.

### 2.1.3 Constraint management

According to the Theory of Constraints (TOC) developed by Goldratt and Cox (1984), the attention of constraint management should be focused on the few constraints which prevent the project and/or organisation from achieving its goal. The initial defined constraint management process within the TOC contains five focusing steps:

- (1) Identify the current constraint;
- (2) Exploit the constraint. Quick improvement will be made to the throughput of the constraint using existing resources (i.e. make the most of what you have);
- (3) Subordinate and synchronise to the constraint. All other activities in the process will be reviewed to ensure that they are aligned with and truly support the needs of the constraint;
- (4) Elevate the performance of the constraint. If the constraint still exists (i.e. it has not been removed), further actions will be taken to eliminate it from being the constraint. Normally, capital investment may be required at this step;
- (5) Repeat the process. The Five Focusing Steps are a continuous improvement cycle. Therefore, once a constraint is resolved the next constraint should immediately be addressed.

Later, Ronen and Spector (1992) enhanced the process by adding two preliminary steps: (1) Define the system's goal; and (2) Determine global performance measurement. Coman and Ronen (2007) extended the TOC and defined an Arena Constraint that influences the organisation's business arena (Spector 2011). In order to align the organisation's core competencies with the business arena's key success factors, five steps were proposed:

- (1) Identify the organisation's constraints;
- (2) Identify the business arena's strategic constraints;
- (3) Analysis the gap between the organisation's and the arena's constraint;
- (4) Outline an action plan aligning the organisation to its business arena;
- (5) Execute the action plan and monitor its effectiveness.

For sophisticated systems that involve many interdependencies (e.g. manufacturing lines), a series of tools have been formalised within the TOC to help the constraint management process mentioned above. Examples of these tools include:

- Current Reality Tree that documents the current state and helps to identify constraints;

- Evaporating Cloud Tree that evaluates potential improvement and helps to resolve constraints;
- Future Reality Tree that documents the future state and reflects the results of eliminating the identified constraints;
- Strategy and Tactics Tree that provides an action plan for improvement.

The aim of constraint management within the LPS, WFP or AWP, is to assure all the constraints on tasks in the look-ahead are removed prior to those tasks' scheduled start (LCI 2007). Currently, the constraint management process is performed during the six-week look-ahead planning phase (LCI 2007). A complete constraint management process should include four sequential sub-processes: constraint identification, constraint modelling and analysis, constraint monitoring and status updating, and constraint removal. However, in current constraint management practice, the sub-processes of constraint modelling, analysis, and monitoring are either neglected or simplified due to the shortage of supporting tools or methods (Hamzeh 2009; Alsehaimi et al. 2009; Alsehaimi et al. 2014; Lindhard and Wandahl 2014). Detailed constraint management process within LPS, WFP, and AWP are critically reviewed as follows.

### **(1) Constraint management in LPS**

LPS has been widely used on projects and within both design and construction firms across a multitude of different sectors in the building, mining and oil and gas industries. In essence, LPS enables the collaborative management of the network of relationships and communications needed to guarantee effective programme coordination, production planning and project delivery (Hook and Stehn 2008; Hamzeh et al. 2015). An action research study conducted by AlSehaimi et al. (2014) indicated that the benefits of LPS include: improved construction planning, enhanced site management and better communication and coordination between the parties involved; and the barriers to release the full potential of LPS contained: lengthy approval procedure by client, cultural issues, commitment and attitude to time and short-term vision.

In LPS, the main task of the look-ahead process is to efficiently schedule the potential task assignments for the next 3–12 weeks. The number of weeks over which a look-ahead process extends is decided based on project characteristics, the reliability of the planning system and the lead times for acquiring information, materials, labour and equipment (Ballard, 2000). Once assignments are identified, they are subjected to constraints analysis to determine what must be done in order to make them ready to be executed. Only activities, in which all constraints have been removed and that they are in the proper sequence for execution, are allowed to enter into the workable backlog. Weekly work plans are then formed from the

workable backlog, thus reducing the uncertainties and improving the productivity. If the planner is not confident that all the constraints can be timely removed, or of identifying a constraint (e.g. engineering drawings) that definitely cannot be removed in time, the assignment would not be allowed to move forward.

Different types of assignments have different constraints which vary from internal constraints (e.g. design information, materials, prerequisite work, space, equipment and labour) to external constraints (permits, inspections, approvals and weather). Nieto-Morote and Ruz-Vila (2011) applied LPS in a chemical plant construction, and two useful conclusions related to constraint analysis were made: (1) identifying constraints of the planned work had a positive impact on the percentage and quality of completed activities; and (2) the process of constraint identification should be conducted by all of the project leaders, supervisors and contractors. Hence, good constraints analysis requires all relevant parties to actively manage their production and delivery, and provides the coordinator with early warning of problems, ideally with sufficient lead time to plan around them.

However, the current process of constraint management within LPS is sluggish and negative, such as the late implementation of constraint analysis and short lead time for constraint removal (Hamzeh 2009). Another problem is that constraints which have a lead time beyond the weekly work plan window cannot be identified and removed in time due to poor foresight capacity of the look-ahead plan (Hamzeh 2009). In addition, paper-based constraint analysis and meeting-based constraint status updating and coordination are still the dominant approaches for constraint removal (Wang et al. 2016).

## **(2) Constraint management in WFP**

WFP is the process of organising and delivering all the elements necessary, before the work is started, to enable craft persons to perform quality work in a safe, effective, and efficient manner (Fayek and Peng 2013). This is accomplished by breaking down construction work by trade into discrete work packages that completely cover the scope of work for a given project (Fayek and Peng 2013). More specifically, WFP relies on the creation of small and well-defined work packages for the construction workforce with a typical rotation of work (5 or 10 days) for one crew in one discipline. In recent years, WFP has been widely used in industrial projects (e.g., oil and gas plant) and is now a common requirement in the construction contracts in Alberta, Canada (Fayek and Peng 2013). The main objective of WFP is to reduce schedule and cost overrun, and improve labour efficiency in mega projects (Fayek and Peng 2013). High-level benefits identified from previous case studies include: improved project party alignment & collaboration, increased site productivity, reduced construction rework, improved

project control, improved safety awareness, increased reporting accuracy, and improved client satisfaction (O'Brien et al. 2011).

Within WFP, three different levels of work packages are defined and used to describe different levels of project plans: Construction Work Area (CWA), Construction Work Package (CWP) and Field Installation Work Package (FIWP) (PMP 2009). Each package cannot be released until all the related constraints are removed. Examples of constraints for work packages are: drawings, workforce, materials, equipment, work space, permission and a scope definition of the work package to be executed. However, the constraint removal process of WFP has three shortcomings: (1) short time for planners to optimise scarce resources; (2) negative attitude for constraint removal due to the lack of constraint tracking, and (3) limited understanding of identification and classification of the full range of constraints.

### **(3) Constraint management in AWP**

AWP, which aims to align engineering, procurement and fabrication with the sequencing needs of site installation, turnover and operations, is developed by a joint venture between the CII and the COAA (Hamdi 2013). The purpose of AWP is to fill the gap between the Front End phase and the Construction phase in terms of work packaging. AWP is a more complete work packaging system than WFP. It covers both the construction and the initial early stages of the project and allows more control over the breakdown of the project through its lifecycle (Hamdi 2013). The three key deliverables of AWP are CWP, Engineering Work Package (EWP) (Hamdi 2013) and Installation Work Package (IWP). A CWP defines a logical and manageable division of work within the construction scope (Hamdi 2013). An IWP is a deliverable to a construction work crew that enables a crew to perform quality work in a safe, predictable, measurable, and efficient manner (Hamdi 2013). CWP is the basis for the development of detailed IWPs, and CWP can contain one or more EWPs. Although the scope of constraints in AWP is extended to engineering and procurement when compared with WFP and LPS, constraint removal in AWP has similar shortcomings due to a similar constraint removal process.

## **2.2 Constraint Modelling and Analysis**

In this section, previous works related to constraint modelling are reviewed firstly. Then, two types of network-related modelling methods are introduced: (1) Social Network Analysis (SNA); and (2) Dynamic Network Analysis (DNA). Finally, a summary of the two methods is concluded in terms of their feasibility in constraint modelling and analysis in LNG construction projects.



### **2.2.1 Current approaches for constraint modelling and analysis**

Unsolved constraints are the main causes of unstable construction work flow (Chua et al. 2003). These constraints are normally hidden and difficult to be controlled as project progresses. Effectively modelling these constraints is important for project managers to identify key constraints and remove them in a timely manner. In the last ten decades, a wide range of approaches had been developed for modelling and analysing constraints. These approaches can be classified into the following three main categories:

#### **(1) Mathematical model-based constraint modelling and analysis**

This approach is widely used in current construction industry together with conventional planning methods such as CPM (Suhail and Neale 1994; Zareei 2018) and Line of Balance (Arditi and Albulak 1986; Al Sarraj 1990; Arditi et al. 2002). Constraints such as time and cost are efficiently modelled, analysed, and optimised to improve project performance. For instance, Li and Love (1997) applied genetic algorithms to facilitate time-cost optimisation. El-Kholy (2013) presented a linear programming model for schedule optimisation considering the variability of funding and uncertainty of project duration. Al Haj and El-Sayegh (2015) proposed a nonlinear-integer programming model to solve the time-cost optimisation problem taking into account the impact of total float loss. Koo et al. (2015) developed an integrated multi-objective optimisation model based on the concept of the Pareto front to solve the time-cost trade-off problem. As projects are unique in nature, an array of constraints (not only the time and cost constraints) should be considered such as technological and organisational constraints, as well as the availability of resource including labour, equipment, material and information (Jaśkowski and Sobotka 2006, Zhou et al. 2013). However, most of the previous studies are only focused on modelling precedence and/or resource constraints (Zhou et al. 2013). Constraint types considered in this approach were limited to time and cost (Feng et al. 1997, Li and Love 1997, Chassiakos and Sakellaropoulos 2005), quality (Zhang and Xing 2010), resource (Hegazy 1999, Cheng et al. 2013), space (Akinci et al. 2002, Bansal 2010), and information (Sriprasert and Dawood 2003).

#### **(2) Simulation-based constraint modelling and analysis**

This approach has been proposed as a definitive method for analysing time and resource constraints since 1960s (AbouRizk 2011). A series of popular tools such as CYCLONE (Halpin 1977), COSYE (AbouRizk and Hague 2009), STROBOSCOPE (Martinez and Ioannou 1996) have been developed to facilitate the implementation of this approach (AbouRizk 2011). Mohamed et al (2007) applied a Discrete-Event Simulation model to analyse project main constraints such as time, space, crews, and physical constraints. Shi and

AbouRizk (1997) applied construction simulation technique to optimise resource constraints. Use of simulation techniques in the construction domain has long been mostly limited to the academic community for research purposes (AbouRizk 2011). Some late efforts to transfer the technology to day-to-day use in the industry have been successful. However, the adoption of the technology by the construction industry is still in its infancy (AbouRizk 2011).

### **(3) Visualisation-based constraint modelling and analysis**

Recently, visualisation technologies such as Four-Dimensional Computer-Aided Design (4D CAD) and BIM are widely applied to improve constraint modelling and analysis. For instance, 4D CAD had been successfully implemented to support the analysis of site constraints such as technological dependency (McKinney and Fischer, 1998; Koo and Fischer, 2000), space (Akinci et al., 2000; Dawood et al., 2002), and safety (Hadikusumo and Rowlinson, 2002). BIM has been also utilised to support the modelling process of all the three types of constraints (i.e. engineering constraints, supply-chain constraints, and site constraints) (Shou et al. 2014). With the help of BIM, the project manager can simulate the overall construction process within a computer, and visually analyse constraints based on the pre-determined path of construction. In addition, some hidden constraints such as workspace and safety can be also analysed through 4-D simulation. The most useful capabilities of 4D CAD and BIM is to provide a collaborative platform for the project team to share their knowledge and experience to improve the overall performance of constraint analysis (Fox and Hietanen 2007; Demian and Walters 2014; Wang et al. 2014).

### **(4) Pull-driven constraint modelling and analysis**

Constraint modelling and analysis within this approach are performed during the look-ahead planning stage. Spreadsheet is one of the most popular tools to list constraints for each individual task (Nieto-Morote and Ruz-Vila 2011, Fernandez-Solis et al. 2012, AlSehaimi et al. 2014). Most of the constraint types within the pull planning methods can be considered, however, the interrelationships among constraints are normally ignored (LCI 2007). The resulted constraint lists/models are tree-structure based (as shown in Figure 2-1).

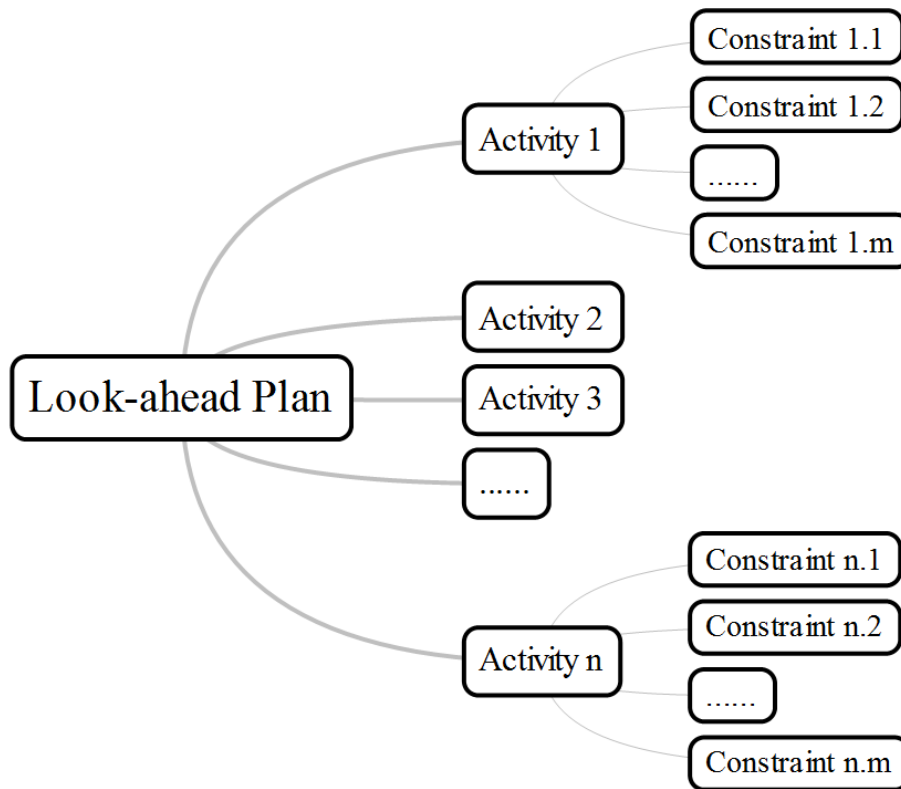

Figure 2-1: Tree-Structure based Constraint Modelling

Table 2-1 illustrates the comparison of the above four approaches in terms of their constraint coverage and capability in constraint modelling and analysis. The first two approaches (i.e. mathematical model-based, and simulation-based approaches) have a very limited constraint coverage. However, both of them are strong in both constraint modelling and constraint analysis. The last two approaches (i.e. visualisation-based, and pull-driven approaches) have a broad coverage of the listed constraints (i.e. engineering, supply chain, and site constraints). However, their capability in constraint modelling and analysis is very low.

Considering the complexity of LNG projects, more than thousands of constraints will be involved in a project. Moreover, these constraints may be interconnected with each other. Therefore, it is impossible to analyse their relationships and impacts by using anyone of the above four existing approaches. There is a need to develop another method that can not only handle all of the three types of constraints but work efficiently in constraint modelling and analysis.

Network science has the potential to fill this gap because (1) Constraints in LNG projects are multi-tiered which means that a given constraint can be exploded into multiple sub-constraints which in turn constrain other constraints and activities. Therefore, the structure of these constraints is a **multi-level network** rather than a simple tree map; (2) Network science is focused on studying complex networks such as telecommunication networks, computer

networks, biological networks, cognitive and semantic networks, and social networks; (3) Network science draws on a number of mature theories and methods which includes graph theory from mathematics, statistical mechanics from physics, data mining and information visualization from computer science, inferential modelling from statistics, and social structure from sociology. These theories and methods are useful to help project stakeholders to understand the relationships and evolution of the constraints that involved in a complex LNG project.

Table 2-1: Comparison of the current four approaches for constraint modelling and analysis

Approaches	Constraint Coverage			Capability	
	Engineering Constraint*	Supply Chain Constraint**	Site Constraint***	Constraint Modelling	Constraint Analysis
(1) Mathematical Model-based	No	No	Yes (Partial)	High (Mathematical Model)	High (Algorithm-driven)
(2) Simulation-based	No	No	Yes (Partial)	Medium (Discrete Event Simulation)	High (Simulation results-driven)
(3) Visualisation-based	Yes (Partial)	Yes	Yes (Partial)	Low (No well-defined modelling engines )	Medium (Human-driven; central visualisation platform-based )
(4) Pull-driven	Yes	Yes	Yes	Low (No well-defined modelling engines )	Low (Human-driven; coordination meeting-based)

\*Engineering constraints: incomplete drawings, lack of assembly specifications, and incomplete 3D models are related to engineering constraints, which affect the start time of procurement, fabrication and site installation.

\*\*Supply chain constraints: late procurement and delivery of bulk materials and project-specific instruments and equipment.

\*\*\*Site constraints: shortage of workforce, lack of temporary structures, limited work space, uncompleted preceding works, bad weather, lack of work permits, and safety issues.

In network science, there are five main network analysis methods that have been developed so far which include: Social Network Analysis (SNA), Electric Network Analysis (ENA), Narrative Network Analysis (NNA), Biological Network Analysis (BNA), and Dynamic Network Analysis (DNA). The aim of the first four network analysis methods is similar (i.e. examining the structure of relationships between nodes in a network) but focused on different domains. The last one (i.e. DNA) is an emergent method that built on top of the traditional methods (e.g. SNA, ENA, NNA, or BNA), which aims to examine the shifting structure of relationships among different classes of nodes in a complex network. In the following two

sections (i.e. Sections 2.2.2-2.2.3), SNA (representing the traditional network analysis methods) and DNA are explained in detail, respectively.

### **2.2.2 SNA method**

SNA examines the structure of relationships between social entities (Pryke 2012). These entities are often persons, but may also be groups, organisations, nation states, web sites, scholarly publications, or project constraints. The concept was introduced by Moreno in 1934 (Moreno 1960). It involves the representation of organisational relationships as a system of nodes or actors linked by precisely classified connections, along with the mathematics that defines the structural characteristics of the relationship between the nodes (Pryke 2012). In SNA, there are two distinct levels of abstraction. Scott (2012) focused on social networks as an interesting social construct and explore the implications for society of such networks while Wasserman and Faust (1994) adopted a wide range of definitions in their networks and tried to understand the mathematical structure of the networks. Wasserman and Faust (1994) argued that any activity requires a transfer of information and knowledge. As such, the transfer of information and knowledge can be mapped within sociograms where actors (e.g. people, departments within a firm, contractors and subcontractors) and information exchange become nodes and arcs within the graph (Wasserman and Faust 1994).

SNA has been considered as an effective tool in analysing project performance in the construction industry (Ruan et al. 2013). The implementation of SNA in the construction industry is on various levels from information exchange, collaboration between project participants to contractual relationships. Early studies focus on interpersonal level in specific conditions and how SNA can be implemented to solve these interpersonal level issues to raise productivity. For example, Loosemore (1998) used SNA in crisis management and found that SNA, as a quantitative tool grounded in an interpretative context, has its strategic advantage in understanding and providing explanations of peoples with interconnected social roles, positions and behaviours. Recent studies begin to apply SNA to construction organisations and place more focus on organisations and governance. These studies cover the roles and relationships of project teams (Di Marco et al. 2010), knowledge sharing between project teams (Chinowsky et al. 2009) and facilitating communication of design teams (Boddy et al. 2009). Given the increasing recognition of globalisation, there are several studies which focus on the implementation of SNA in construction organisations in a global context. For example, Nayak and Taylor (2009) used SNA to examine key issues with outsourcing engineering services across national boundaries. Wong et al. (2009) examined the differences in robust project network designs between domestic and global projects. Park et al. (Park et al. 2010)

investigated the formation of construction firms' collaborative networks for performing international projects.

### **2.2.3 DNA method**

DNA was developed to analyse the rich relational models that represent entities, relations, their properties and how all of those change over time (Carley et al. 2007). Meta-matrix is the basis of DNA and combines knowledge management, operations research and social networks techniques. As the complexity of network increases, the number, type and value of measures in the network analysis will change. It is a key problem in meta-matrix to decide appropriate metrics for describing and measuring dynamic network. For example, Pattison et al. (2003) used four entities of interests, including people, knowledge/resources, events/tasks and organisations. Ten inter-linked networks can therefore be created, including social network (people - people), knowledge network (people – knowledge/resources), attendance network (people - events/tasks), membership network (people - organisations), information network (knowledge/resources - knowledge/resources), needs network (knowledge/resources - events/tasks), organisational capability (knowledge/resources - organisations), temporal ordering (events/tasks - events/tasks), institutional support (events/tasks - organisations) and inter-organisational network (organisations - organisations). Diesner and Carley (2004) added location to the entities of interests and this new addition has created six additional inter-linked networks, which are agent location network, knowledge location network, resource location network, task/event network, organisational location network and proximity network. As the complexity of the problem increases, more entities of interests and inter-linked networks will be created.

In meta-matrix, the inter-linked networks are probabilistic. Various techniques, mostly computational techniques, have been developed to estimate the probability and incorporate dynamic network information. For example, Butts (2003) used Bayesian updating techniques to draw direct inferences regarding posterior probabilities. The technique helps to address the problem of network inference and informant accuracy in traditional network analysis. Other systematic algorithmic approaches have also been developed in recent years mainly in the context of information networks. For instance, Kempe et al. (2003) developed a discrete optimization model to choose the most influential members of the network. Kleinberg (2002) used a general model of group structures to address the problem of decentralized search in networks with partial information about the underlying structure. Berger-Wolf and Saia (2006) proposed a new mathematical and computational framework that enables analysis of dynamic social networks and that explicitly makes use of information about the time that social interactions occur.

Table 2-2 illustrates the comparison between SNA and DNA. SNA is focused on single or at most two mode data and facilitate the analysis of only one type of link at a time (Carley 2003). In contrast, DNA is developed for large-scale networks that contain multi-nodes, multi-links, and multi-levels. Multi-node means that there are many types of nodes such as people, locations, and organisations. Multi-link means that there are many types of edges such as, friendship, and membership. Multi-level means that some nodes may be members of other nodes, such as a network composed of people and organisations and one of the edges is who is a member of which organisation. In addition, the links in DNA are not binary. They represent the probability that there is a link.

According to the comparison results shown in Table 2-2, DNA technique is selected as a main method for constraint modelling and analysis in LNG construction. The reasons are listed as below:

- The structure of constraints in LNG construction is a **multi-node** network. There are at least four types of nodes existed in the Constraint Network, i.e. *Agents*, *Work Packages*, *Constraints*, and *Organisations*.
- The structure of constraints in LNG construction is a **multi-link** network. There are more than four types of links should be defined in the Constraint Network. For instance, “*sequence link*” needs to be defined between *work packages* (i.e. *CWPs* and/or *IWPs*) to indicate which one will be executed firstly; “*superintendent link*” needs to be defined between *work packages* and *agents* to indicate who is in charge of which work package; “*membership link*” needs to be defined between *agents* and *organisations* to indicate who is belong to which organisation; and “*constraint link*” needs to be defined between *work packages* and *constraints* to indicate which constraints should be removed before executing a work package.
- The structure of constraints in LNG construction is a **multi-level** network. The nodes of *work package* have two levels: Level 1 includes *CWPs*, *EWPs*, and *PWPs*; Level 2 contains *IWPs* (because a *CWP* can be further divided into a number of *IWPs*).
- The structure of constraints in LNG construction is a **dynamic** network because new constraint will be added and/or old constraints will be removed as project progresses.
- The “*constraint link*” defined between *work packages* and *constraints* is not a binary link.

Table 2-2: Comparison between SNA and DNA

No.	Comparison	SNA	DNA
1	Network type	Static	Dynamic
2	Network size	Small	Large
3	Network level	Single-level	Multi-level

4	Node type	Single-node or at most two types of nodes	Multi-node
5	Edge type	One type	Multi-plex
6	Link type	Binary link [0, 1]	Probability-based link (0, 1)
7	Network measures	Measures from Network Science (e.g. Density, Centrality, and Degree)	Measures from Network Science, and Simulation Models

#### 2.2.4 Summary

The structure of constraints in LNG construction is a dynamic network with multi-levels, multi-nodes, and multi-links. Current approaches (i.e. mathematical model-based, simulation-based, visualisation-based, and pull-driven approaches) cannot efficiently model and analyse this type of constraints. Both SNA and DNA methods have potentials to solve this problem. However, compared with SNA, DNA is more powerful and focused on large-scale networks that contain multi-nodes, multi-links, and multi-levels. In addition, DNA method treats links as probabilistic not binary.



## **2.3 Cross-domain Constraint Information Sharing**

In this section, current approaches for constraint information sharing are reviewed. The challenges of current approaches are then summarised and presented. In order to address these challenges, semantic web technology in information management is reviewed. In order to improve the use of semantic web technology in improving cross-domain constraint information sharing in the LNG industry, two new concepts are also introduced: (1) ISO 15926, which is a standard for integrating life-cycle data for process plants including LNG production facilities; and (2) linked data technology, which complements the semantic web.

### **2.3.1 Current approaches and challenges in constraint information sharing**

Constraint information sharing across domains is essential for determining the status of tasks in the look-ahead window. Currently, these sources of constraint information are stored in different ways, at various locations and by multiple vendors from different domains. It is difficult for project participants to efficiently access these sources of information through simple searchings. Moreover, due to the increasing complexity and size of LNG plants, more vendors are engaged in a project than before which makes the situation of constraint information sharing even worse.

Current approaches for constraint information sharing can be classified into the following three categories: (1) Meeting- and paper-based approaches; (2) Internet/Web-based approaches; and (3) Building Information Modelling (BIM)-based approaches. Each of them is explained in detail as follows.

#### **(1) Meeting- and paper-based approaches**

This type of approaches is widely used in current construction projects, especially those of small and middle scale size. Regular meetings that are conducted weekly or monthly provide opportunities for project participants to share and update constraint information. For instance, engineering participants can bring their latest drawings or design progress reports to the meetings to help project planners update the status of the engineering constraints. In some cases, meeting minutes are circulated for participants to review (Liston et al. 2003). Using periodic reports is another way to share constraint information. Each project party (i.e. designers, contractors, subcontractors, and suppliers) needs to prepare weekly, monthly or quarterly progress report to the client. If the contractors want to understand the delivery status of a specific material, they can ask for the progress reports from the corresponding supplier.

The main advantage of this type of approaches is easy implementation, however, a number of drawbacks need to be highlighted. Project participants, who are involved in either meetings or

paper-based reporting processes, spend most of their time trying to understand the project information rather than using the information to address “What-If” questions. According to Liston et al. (2003), four issues have been identified: (1) Information is not interactive and real-time; (2) Focus of information, either used or referenced, is not shared; (3) Views don't visually represent critical relationships, such as relationships between time, cost, space, safety requirement, and permit; and (4) Views are inappropriate for group use, such as the Gantt chart which only provides an overall context, but is not adequate for any group task.

## **(2) Internet/Web-based approaches**

The Internet provides a nearly ubiquitous platform for information sharing among various project participants (Kong et al. 2004). It also provides well-established protocols for data security and reliability (Kong et al. 2004). Abdelsayed and Navon (1999) developed a simple internet-based model, which is based on a single repository of multiple project database, to enhance information sharing and access in construction projects. Tsai et al. (2006) proposed a web-based information sharing system for facilitating collaborative product development. Furthermore, a role-based access control mechanism was also developed to allow secure and fine-grained access control for each piece of data (Tsai et al. 2006). In order to solve the interface issue among various project stakeholders, Huesemann (2006) developed a web-based platform which adopts a service-oriented architecture for improving information exchange.

In the construction industry, a number of internet/web-based applications have been developed to improve project management performance and information exchange. Deng et al. (2001) developed an Internet-based project management system to facilitate information sharing with the functions of Internet chat, live video-cam, and search engine. Dawood et al. (2002) proposed an automated integrated environment for communication, retrieval, storage and distribution of project documents among project teams. Chassiakos and Sakellariopoulos (2008) presented a data-centric web databases in enhancing construction information management and communication.

While the Internet providing a convenient and inexpensive approach for information sharing, unstructured information is the main concern faced by project stakeholders when searching a specific piece of data (Huesemann 2006, Tsai et al. 2006, Forcada et al. 2010). Search results are limited by search conditions such as keywords, full texts and the use of natural language (Forcada et al. 2010). Each project discipline, such as engineering or construction, uses different terminologies to describe their work activities and statuses. Therefore, the search terms must also be discipline-specific so as to improve the probability of finding the expected document.

### **(3) Building Information Modelling-based approaches**

BIM is emerging as a method of creating, sharing, exchanging and managing the information throughout life cycle among all stakeholders (Eastman et al. 2011, Pour Rahimian et al. 2014, Wang et al. 2014). Constraint information such as engineering, supply-chain, and construction site constraints can be all linked or integrated into a central BIM platform.

In the project planning and design stages, BIM platforms such as Autodesk Buzzsaw (Autodesk 2017a) and Bentley ProjectWise (Bentley 2017) are widely used for managing and sharing engineering constraint information, such as design progress and engineering drawings. Plume and Mitchell (2007) presented a BIM-enabled collaborative design case using a shared Industry Foundation Classes (IFC) building model. Oh, et al. (2015) developed an integrated BIM system for improving design information sharing among different disciplines. Kassem et al. (2014) proposed a number of protocols that could be utilised at project level to increase the efficiency and consistency of information flow and BIM deliverables. Issues like interoperability of BIM and other tools of managing constraint information were also discussed by Grilo and Jardim-Goncalves (2010).

In the project construction stage, BIM combined with other sensing technologies can be used for site constraints information sharing, such as the availability of equipment, tools, labour, and materials. For instance, Costin et al. (2015) utilised passive Radio Frequency Identification (RFID) to track and update the site constraint of personnel, and upload the real-time information into BIM model for referencing by other construction teams. Fang et al. (2016) introduced an integrated system of BIM and cloud-enabled RFID for indoor location tracking of mobile construction resources including equipment, tools, and labour. In terms of site constraint of predecessor work, Golparvar-Fard et al. (2012) proposed an automated approach for recognition of physical progress or percentage completion of preceding works based on unordered daily construction photos and BIM models. Kim et al. (2013) developed another automated method which used a BIM in concert with 3D laser scanning data for construction progress measurement.

Despite many efforts spent on exploring emerging information technologies to improve constraint information sharing, there are still a number of challenges faced by project teams. The four most prominent challenges are discussed as follows:

#### **(1) Lack of single source of truth**

Corporations in an LNG project always have their own information systems to store constraint data. Most of these systems are directly purchased from software vendors and cannot be modified in non-trivial ways. Therefore, data is duplicated in many places, often updated on a

casual basis, and has little clarity related to which copy of the data is the most current. For instance, drilling system designed by a speciality company will store the engineering drawings (i.e. engineering constraint data) in their internal information system. Corporations such as other related engineering companies, plant operators, general contractors, and speciality sub-contractors will get and store a copy of the drilling design drawings. Drill supplier or manufacturer will also need a copy of the same data. Because of the lack of a synchronisation mechanism among these isolated systems, it is very common that each system maintains different versions of the same data. Therefore, the status of each constraint cannot be accurately shared which in turn will have a negative impact on the construction work flow.

## **(2) Inefficient data exchange**

To achieve an efficient constraint data exchange, data formats need to be harmonised in order to improve syntactic interoperability (Mead 2006). Currently, most of the structured constraint data are stored in relational databases with different schemas. A unified schema-enabled data exchange across multiple databases is the mainstream in the last few decades, however, when the schema evolves, information systems using this type of scheme need to be adapted accordingly. Over time maintaining these schemas requires significant effort and can be quite inflexible.

## **(3) Lack of a common vocabulary**

There is not a common vocabulary developed for LNG Plant construction and constraint management. Each system uses its own domain vocabularies to describe the same constraint data. For instance, manufacturers use the ISO 10303 (Automation systems and integration — Product data representation and exchange) to specify a centrifugal pump while plant operators use ISO 15926 (Industrial automation systems and integration—Integration of life-cycle data for process plants including oil and gas production facilities). An experienced mechanical engineer is needed to figure out which data have value and need to be transferred from the manufacturer's data sheet to the owner's data sheet. Without human intervention, the problem of implied meaning based on context becomes a serious barrier for data transfer.

## **(4) Lack of efficient searching tools**

For structured constraint data stored in relational databases, Structured Query Language (SQL) is the main searching tool to get demand information (Bosc et al. 1988). Due to the limitation of the relational dataset, constraint relationships are very hard to be stored and maintained. Therefore, it is difficult to find all the constraints of one work pack in one time. In addition, the SQL query reflects the specific structure of a database and how the data is stored in tables within it, not the user's understanding of the domain.

For unstructured constraint data stored in various formats such as Microsoft Word documents, Adobe Portable Document Format (PDF) files, spreadsheets, and Hypertext Markup Language (HTML) pages, a text/keyword-based search can be conducted. However, the performance of the search is heavily relying on the keyword selection. If the keyword is too specific, the search results exclude documents that may be relevant. On the contrary, if the keyword is too generic, the search results include too many irrelevant documents. Even if the document is stored in a well-classified and structured format, various carefully selected keywords should be used to get the desired information.

### **2.3.2 Semantic web technology**

Semantic web technology originated from web development has brought new tools, concepts, and methodologies which are increasingly employed in project/product lifecycle information exchange management (Fortineau et al. 2013). For instance, Niknam and Karshenas (2015) applied semantic web technology to integrate distributed sources of information for construction cost management such as a BIM models created by designers, estimating assembly and work item information maintained by contractors, and construction material cost data provided by material suppliers. Pauwels et al. (2011) adopted semantic web technology for improving 3D information exchange in the domain of architecture, engineering, and construction.

Ontology is one of the major cornerstones of semantic web technology, and has been successfully applied as a semantic enabler of communication between both users and applications in fragmented, heterogeneous multinational project environments (Sure et al. 2002, Beetz et al. 2009, El Kadiri and Kiritsis 2015). In building and construction projects, there are a number of ontologies which have been developed to improve cross-domain information sharing, such as safety ontology (Zhang et al. 2015), IfcOWL (Beetz et al. 2009), defect ontology (Park et al. 2013, Lee et al. 2016), construction event ontology (Le and Jeong 2016), and condition survey ontology (Le and Jeong 2016). In LNG industry, ISO 15926 is the major standard that used for integrating life-cycle data of process plants including oil and gas production facilities. The following two sections review the ISO 15926 and linked data technology in detail, respectively.

### **2.3.3 ISO 15926**

ISO 15926 is a standard for data integration, sharing, exchange, and hand-over between computer systems (Wikipedia 2017). The full title of ISO 15926 is “*Industrial automation systems and integration—Integration of life-cycle data for process plants including oil and gas production facilities*”. Currently, there are thirteen parts:

**(1) Part 1: ISO 15926-1:2004** (Overview and fundamental principles)

This part specifies a representation of information associated with engineering, construction and operation of process plants (ISO 2004). This representation supports the information requirements of the process industries in all phases of a plant's life-cycle and the sharing and integration of information amongst all parties involved in the plant's life cycle (ISO 2004).

**(2) Part 2: ISO 15926-2:2003** (Data model)

This part specifies a representation of process plant life-cycle information (ISO 2003). This representation is specified by a generic, conceptual data model designed to be used in conjunction with reference data: standard instances that represent information common to a number of users, process plants, or both (ISO 2003). The use and definition of reference data for process plants is the subject of Parts 4, 5 and 6 of ISO 15926 (ISO 2003).

**(3) Part 3: ISO/TS 15926-3:2009** (Reference data for geometry and topology)

This part specifies geometric and topological concepts, enabling the recording of geometric and topological data using ISO 15926-2 and in a way consistent with first order logic (ISO 2009).

**(4) Part 4: ISO/TS 15926-4:2007** (Initial reference data)

This part defines the initial set of reference data for use with the ISO 15926 and ISO 10303-221 industrial data standards (ISO 2007). ISO issues the reference data in the form of spreadsheets, and currently, there are almost 20,000 individual terms (Fiatech 2011).

**(5) Part 5: ISO 15926-5**

This part specifies the procedures for registration and maintenance of reference data. This function has been taken over by an SC4 commission for class library maintenance not only of ISO 15926 but of other ISO reference data libraries contained in databases (Fiatech 2011).

**(6) Part 6: ISO/TS 15926-6:2013** (Methodology for the development and validation of reference data)

This part defines a methodology for the stewarding of reference data for process plants (ISO 2013). It describes how to validate a reference data item to ensure that it is genuine (Fiatech 2011). It also describes the information required for a new reference data item and how to have it approved. It lists the metadata used for the provenance of the objects in an RDL (Fiatech 2011).

**(7) Part 7: ISO/TS 15926-7:2011** (Implementation methods for the integration of distributed systems: Template methodology)

This part provides a methodology for data integration of ontologies using mathematical first-order logic, which makes it independent of computer languages (ISO 2011a).

**(8) Part 8: ISO/TS 15926-8:2011** (Implementation methods for the integration of distributed systems: web ontology language implementation)

This part provides rules for implementing the upper ontology specified by ISO 15926-2 and the template methodology specified by ISO 15926-7 into the RDF and Web Ontology Language (OWL) languages, including models for reference data as specified by ISO/TS 15926-3 and ISO/TS 15926-4, and for metadata (ISO 2011b).

**(9) Part 9: ISO 15926-9** (Implementation methods for the integration of distributed systems: Façade implementation)

This part is still under development.

**(10) Part 10: ISO/NP 15926-10** (Conformance testing)

This part is still under development.

**(11) Part 11: ISO/TS 15926-11:2015** (Methodology for simplified industrial usage of reference data)

This part defines a methodology for simplified industrial usage of reference data as defined in ISO/TS 15926-4 and is applicable to the plant life cycle phases in the process industry supply chain (ISO 2015). The methodology is based on RDF triples, RDF Named Graphs and a standardised set of natural engineering language relationships resulting in a table that can be exchanged and shared easily in industry (ISO 2015).

**(12) Part 12: ISO/CD 15926-11** (Life cycle integration ontology)

This part is still under development.

**(13) Part 13: ISO/CD 15926-13** (Integrated asset planning life-cycle)

This part is still under development.

### **2.3.4 Linked data technology**

In terms of the relationship between linked data and semantic web, a widely held view is that the Semantic Web is made up of Linked Data; i.e. the Semantic Web is the whole, while Linked Data is the parts (Health 2009). According to Bizer et al. (2008), Linked Data is about using Uniform Resource Identifiers (URIs) and Resource Description Framework (RDF) to publish structured data on the Web and to connect data between different data sources. In RDF,

a description of a resource is represented as a number of triples (i.e. subject-predicate-object). The subject of a triple is the described resource; the object can either be a simple literal value or another resource that is related to the subject; the predicate indicates the relation exists between the subject and object. There are two principal types of RDF triples: literal triple and RDF link. The former one is used to describe the properties of a resource. For instance, literal triple can be used to describe the name or age of a person. The latter one explains the relationship between two resources, which can be further divided into internal and external RDF links. Internal RDF links connect resources within a single linked data source, while external RDF links connect resources that are managed by different linked data sources. Therefore, RDF has features that facilitate data merging even if the underlying schemas differ, and it specifically supports the evolution of schemas over time without requiring all the data consumers to be changed (Heath and Bizer 2011, Karagiannis and Buchmann 2016).

Four principles of Linked Data were set out by Berners-Lee (2006) to guide the linked data publishing, which include: (1) Use URIs as names for things; (2) Use Hypertext Transfer Protocol (HTTP) URIs, so that people can look up those names; (3) When someone looks up a URI, provide useful information by using the standards (RDF); and (4) Include links to other URIs, so that they can discover more things. A published linked data resource can be queried using linked data browser, which is similar to the traditional Web of documents accessed through HTML browsers. However, instead of following hyperlinks between HTML pages, linked data browsers enable users to navigate between different data sources by following RDF links (Hartig et al. 2009, Hausenblas 2009, Heath and Bizer 2011).

Linked data enables the flexible virtual integration of multiple data sources, through linking, without requiring to redesign information systems and to centralise data in data silos. This will facilitate the collaboration between different project participants through project life cycle. Commonly-agreed metadata (e.g. vocabularies and ontologies) and common identifiers (i.e. URIs) ensures semantic interoperability when information systems exchange data, thus making the provision of cross-domain information sharing easier. Moreover, the Linked data paradigm does not impact the ownership of the original data. Although RDF links among data sources are established, data owners still keep full control of their original data (Berners-Lee 2006, Bizer et al. 2009).

## **2.4 Constraint Tracking Technologies**

In this section, a number of sensing technologies for constraint tracking are reviewed including their advantages and disadvantages. Dynamic planning and real-time constraint tracking are critical to improve schedule reliability and work flow. Activities in LNG projects are very



complicated due to tremendous pressure to complete projects under conditions of uncertainty in less time and without sacrifice to safety and quality (Sriprasert and Dawood 2003). However, manual constraint tracking is time-consuming and inefficient. Without increased information-technology support, constraint management is generally brute force, left up to instinctive decision making by the experienced project manager and field supervision (Blackmon et al. 2011). A substantial amount of literature related to tracking technologies has been published over the past 20 years. The following review covers technologies of: (1) Barcode, RFID, and Global Position System (GPS); (2) Laser Scanning and Photogrammetry; and (3) Other tracking technologies.

#### **2.4.1 Barcode, RFID and GPS**

Barcode, RFID and GPS are widely used for supply chain constraint tracking from material procurement to delivery on site. Barcode is an automatic identification technology that streamlines identification and data collection. The applications for supply-chain nowadays have massively adopted barcodes in order to control the traceability of the goods, such as instruments and materials tracking, and electronic document management (Lin et al. 2014). As a robust tracking approach, barcode still suffers from a certain amount of problems such as line-of-sight restrictions, and that they are easily damaged (Schmidt et al. 2013), which create obstacles in supply-chain scenarios. Nevertheless, barcoding is still an essential approach in industrial logistics.

RFID technologies have been progressively adopted in tracking material's transportation and status during construction in the past ten years (Schmidt et al. 2013). The RFID system usually contains two main components: readers and tags. RFID readers acquire the information from tags based on radio waves communications between tags and antennas on the readers (Liu et al. 2014). Once the tags of interest have been located within the detecting range of readers, the IDs of these tags can be received and related information regarding the tagged objects can be identified. The RFID systems can be classified into two types: passive and active RFID systems (Kelm et al. 2013). The communication of a passive system only relies on the signal emitted from the antenna of the reader. Tags are responsible for the signal reflection based on their induction coils without battery support, which only offers a short communication range. On the contrary, the active system identifies information by triggering tags and receiving tags' active signal responses.

Due to its decreasing cost and relatively long range communication, RFID has attracted a lot of interests from both researchers and industry professionals. Examples of their use include indoor location identification for construction projects (Montaser and Moselhi 2014), construction components localisation (Ergen et al. 2007), and material supply chain tracking

(Young et al. 2011, Demiralp et al. 2012). However, the tracking system is still suffering from environmental factors, which negatively impact the reliability of massive utilisation for total supply-chain management. The environmental factors affect the magnetic flux and weaken the radio frequency signal (Jeffery et al. 2006). They include multipath fading issues (Sabesan et al. 2012), the presence of metal and liquid in the vicinity of the tag and so on.

GPS, as an outdoor localisation technology, can provide logistic information frequently. It can be utilised for transportation tracking in a medium-or long-range area, such as tracking material movement from a warehouse to a construction site. GPS was firstly initialized in the United States during the 1970s. With the assistance of satellites running on the orbit of the earth, the ground-based equipment contains a transmitter and a receiver which is usually combined into a single unit and is responsible for collecting and decoding the signal from satellites (Brewer et al. 1999). The latitude, longitude, and altitude of the unit can be determined by triangulation calculations according to the positions and time off-sets of four satellites. Such tracking approaches are now commonly used in the trucking industry.

#### **2.4.2 Laser scanning and photogrammetry**

Accurate and rapid assessment of the as-built model is important for project planners to manage and track site constraints such as predecessor work, work space, and quality. Rapid project assessment further identifies discrepancies between the as-built and as-planned model, and facilitates decision making on the necessary remedial actions (Golparvar-Fard et al. 2011). Currently, there are two types of technologies for creating as-built model: laser scanning and photogrammetry.

Laser scanning is an active sensor technique that captures geospatial information of a scene, delivering thousands of points with Cartesian (x-y-z) or spherical ( $\Phi$ - $\theta$ -r) coordinates (Becerik-Gerber et al. 2011, Bhatla et al. 2012). To capture all aspects of the objects, scans from multiple locations are needed because they only capture data within their line of sight (Becerik-Gerber et al. 2011). In construction industry, laser scanning is used for progress tracking (Shih et al. 2007, Kim et al. 2013, Zhang and Arditi 2013), quality control (Wang et al. 2014), as-built model development (Bosché 2010, Turkan et al. 2012), indoor mapping (Surmann et al. 2003, Biber et al. 2004), and construction metrology (Hashash et al. 2005, Walters et al. 2008). Despite high accuracy of laser scanners and dense reconstruction of the as-built models, a set of limitations and challenges have been found during implementation. These limitations include (1) high cost needed to purchase equipment, train workers and process point cloud data; (2) long time required to perform a single scan when using high angular resolution; and (3) massive number of scan-positions necessary to acquire accurate and complete information (Golparvar-Fard et al. 2011).

Photogrammetry feeds the measurements from remote sensing and the results of imagery analysis into computational models in an attempt to successively estimate actual site environment (El-Omari and Moselhi 2008, Bohn and Teizer 2009, Yang et al. 2010, Brilakis et al. 2011, Yang et al. 2011, Bhatla et al. 2012). In the construction industry, high-speed imaging and remote sensing devices are employed to detect, measure and record complex 3D fields. Kim et al. (2013) presented an image-processing-based methodology for the automatic updating of a 4D CAD model. Bhatla et al. (2012) evaluated the accuracy of as-built 3D modelling from photos taken by handheld digital cameras. When compared with laser scanning technology, photogrammetry in the current state is not suitable for modelling infrastructure projects, however, technological developments can enable it to be an efficient way to extract measurements of inaccessible objects for progress tracking and decision-making purposes (Bhatla et al. 2012).

#### **2.4.3 Other tracking technologies**

Apart from the three types of tracking technologies mentioned above, Ultra-wide Bandwidth (UWB), Bluetooth and Wireless local area network (WLAN) are also used to track construction equipment, labour and material. UWB belongs to the radio frequency positioning family (Li et al. 2016). The feature of UWB is its short pulse which allows the filtering of the reflected signal and further helps overcome multi-path distortion for more accurate positioning results (Ingram et al. 2004); Bluetooth, which can only obtain two-dimensional positioning data, are known to be extremely accurate in indoor environments (Li et al. 2016). WLAN system can reuse the existing network infrastructure of the site and be used to calculate the position of the subject based on signal strength as well (Khoury and Kamat 2009). The limitation is the need for the target to be connected to the WLAN (Li et al. 2016).

#### **2.4.4 Summary**

Regarding the performance of the state-of-the-art tracking approaches, it is believed that one or two single identification technologies are not likely to meet the need of comprehensive constraint tracking in LNG projects. In order to tackle this issue, there is a need to develop a hybrid solution through integrating multiple tracking devices and methods. By selecting the most appropriate group of tracking technologies, the advantages of these technologies can be amplified while the drawbacks are minimized because they are complementary to each other. This is especially important for complicated cases, such as LNG projects and the development of a total constraint tracking method is therefore necessary.

## Chapter 3: Research Methodology

This chapter examines the research methodology adopted in this thesis. It first outlines the research philosophy that underpins the approach taken with the research, discussing the researcher's *positivism stance* to research and the consequent choice of a mixed research approach (i.e. qualitative and quantitative approaches). The next section discusses the rationale for the research design, and the reasons for adoption of *Focus Group Study* and *Experimental Research Method*. It also provides an overview of the data collection methods used for the thesis, as well as the methods used to analyse the data.

### 3.1 Research Philosophy

#### 3.1.1 Paradigm

Guba (1990) defined paradigm as a basic set of beliefs that guide action. Paradigms deal with principles, or ultimates (Denzin and Lincoln 2011). Denzin and Lincoln (2008) (p. 245) suggested paradigms as basic belief systems based on ontological, epistemological, and methodological assumptions. They are the philosophical stances of the research. Ontology discusses the beliefs of the nature of reality and humanity, epistemology is the theory of knowledge that informs the research, and methodology focuses on how the knowledge can be acquired. A comprehensive consideration of ontology, epistemology, and methodology is a central feature of social science research (Guba and Lincoln 1994).

Ontology is the study of reality (Crotty 1998). Blaikie defined ontology as the study of “*claims and assumptions that are made about the nature of social reality, claims about what exists, what it looks like, what units make it up and how these units interact with each other*” (Guba and Lincoln 1994, p.10). The ontological position of a research is the investigation of the nature of the reality. The popular example of ontological positions includes objectivism vs. constructivism (Sutrisna 2009). Objectivism claims that the empirical fact is the objective reality which exists independently from personal ideas or thoughts, so that everyone experiences the same way to the reality (Sutrisna 2009, Crotty 1998). Constructivism claims that the world is continually being constructed, interpreted, and accomplished by people in their interactions with each other and with wider social society, so that everyone constructs the reality differently (Sutrisna 2009, Marczyk, DeMatteo, and Festinger 2005).

Epistemology concerns the claim of “*what is assumed to exist can be known by the knower or to-be-knower*” (Guba and Lincoln 1994). It is defined as “*the theory of knowledge embedded in the theoretical perspective and thereby in the methodology*” (Crotty 1998) (p.3). It deals with what it means to know of the nature, sources, and processes of knowledge and knowing

that to be created, acquired and communicated (Cohen et al. 2013). Epistemology is the view of how one acquires knowledge. Epistemology looks at especially the methods and the possible ways of gaining knowledge in the assumed reality (Sutrisna 2009). The two broad epistemological positions are positivism vs. interpretivism (Sutrisna 2009). Positivism advocates the application of methods to observe, study the reality and discover the truth according to the same principles of natural science (Sutrisna 2009, Bryman 1984). Interpretivism claims that the reality separates from the observers/researchers, the truth of the reality is constructed individually and interpreted from their own viewpoint (Sutrisna 2009).

Objectivism is the basis of positivist to understand reality with the focus on experiencing only one reality by all observers/researchers. Constructivism is the basis of interpretivist to understand reality with different viewpoints. It is argued that the philosophical view may be divided into two dimensions: one with objectivist ontology and positivist epistemology, another with constructivist ontology and interpretivist epistemology.

### **3.1.2 Deductive and Inductive Research**

The next level of research methodology is the discussion on the reasoning of research (Sutrisna 2009). It refers to the logic of the research, which focuses on exploring the role of existing body of knowledge gathered from the literature study, the way researchers utilise the data collection and subsequent data analysis (Sutrisna 2009). Deductive and inductive research are the two ways of reasoning. The logic of deductive research is composing hypothesis based on current body of knowledge (one objective truth), followed by data collection and analysis to test the hypothesis, whilst the logic of inductive research starts by conducting data collection and analysis to come up with findings, then using the current body of knowledge to inform the data analysis when researchers see appropriate (Sutrisna 2009).

### **3.1.3 Qualitative and Quantitative Research**

The research methodology used in social science can generally be divided into qualitative and quantitative. Quantitative approaches follow the ontological position of objectivism. They are based on the positivistic ideal – an idea of independently existing reality that can be observed as it is. Quantitative methodology is routinely described as an approach to test theories deductively, a focus on gathering factual data, carrying on controlled inquiry against bias, and quantifying objective explanation (Steckler et al. 1992). Researchers are verification and outcome-oriented, and the results are viewed as generalisable, replicable and capable of isolation from reality (Slevitch 2011, Tuli 2011). Quantitative research is usually designed under experimental conditions to test theories. It is conducted in an attempt to answer questions such as why something happens, what causes some events, or under what conditions

an event does occur (Hughes 2012).

Qualitative methodology is inductive. It is based on constructivism and interpretivism (Steckler et al. 1992). Qualitative methods focus on investigating the quality of phenomena, taking into account the interactions between reality and researchers, and explaining the phenomena from the viewpoint of participants. The data used in qualitative research are subjective as the events are understood and explained when researchers immersed in the context. Qualitative approaches are discovery and process oriented; the results are less concerned with generalisability and replicability (Tolley et al. 2016, Tuli 2011). Qualitative research is usually used to suggest possible relationships, effects and dynamic processes (Hughes 2012). Mixed methods are the combination of both qualitative and quantitative research approaches. It involves the mixed use of qualitative and quantitative methods concurrently or subsequently in the study of the same phenomenon (Creswell and Clark 2007).

This study aims to develop and validate a TCM method to improve plan reliability and work productivity in LNG construction. A positivist epistemology was adopted in this research. Mixed methods of both qualitative and quantitative methods were conducted subsequently in this research. More specifically, focus group study method was conducted to facilitate the development of the TCM framework while experimental methods including lab-based experiments (i.e. Lean Simulation Game) and field experiments were conducted to validate the effectiveness and efficiency of the proposed TCM framework.

### **3.2 Research Design**

Within a positivist epistemology stance, this thesis is focused on developing and validating a TCM method to improve plan reliability and work productivity in LNG construction. The review of existing constraint theories, and constraint management practices in Chapter 2 has shown that there are significant research gaps in constraint modelling, constraint information sharing, and constraint monitoring. Figure 3-1 illustrates the overall research design for this thesis. Three types of research methods were applied: Focus Group Study, Experimental Research (i.e. Laboratory and Field Experiments), and Linked Data Development Method. Each of them is discussed in detail in the following sections.

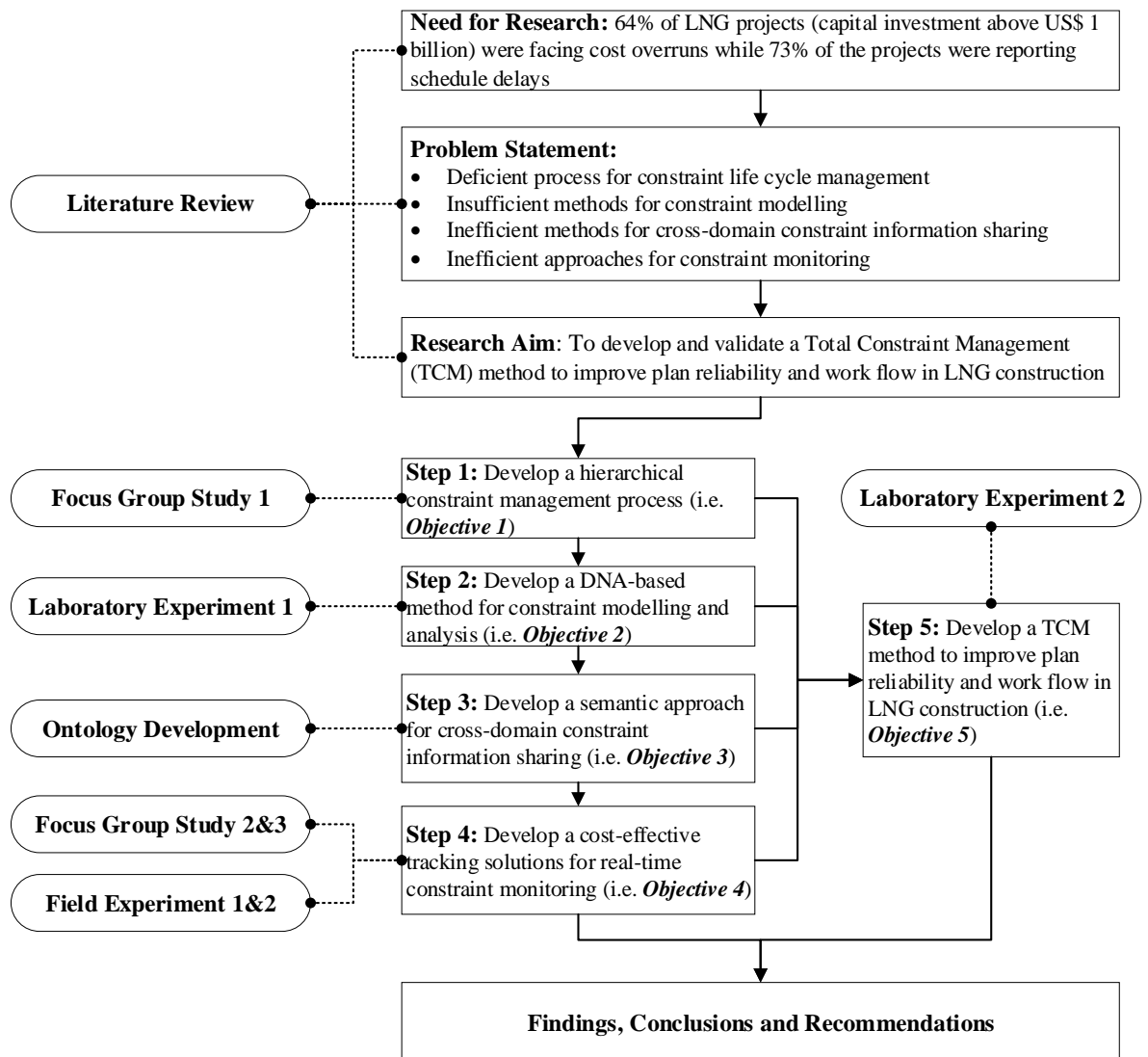

Figure 3-1: Research Design

### 3.2.1 Focus Group Study

Focus group study aims to obtain data from a purposely selected group of individuals rather than from a statistically representative sample of a broader population (O.Nyumba et al. 2017). The discussion is guided by a skilled facilitator who provides the topics. Focus groups are conducted with 7–12 people. Participants should be relaxed, and the discussion should flow naturally to maximize the sharing of ideas (EI-Sabek et al. 2018). This method is frequently used as a qualitative approach to gain an in-depth understanding of social issues (O.Nyumba et al. 2017). In construction research area, a significant number of researchers had applied this method in their studies to explore stressors of construction professionals (Leung and Chan 2011), identify critical factors of public engagement in project development phase (Leung and Chan 2013), analyse risk factors in high-rise construction (Kim et al. 2016), and validate framework of managing integration challenges (EI-Sabek et al. 2018). According to Figure 3-

1, three focus group studies had been conducted. Each of them is explained in detail as follows including data collection and analysis.

### **(1) Focus Group Study 1**

#### *Participants*

The aim of this focus group study is to facilitate the development of the TCM framework (Objective 1). An optimal group size of 5-12 participants was preferred to create a balance between depth and breadth of data collection (EI-Sabek et al. 2018). To control data quality, purposive sampling was adopted (Patton 1990). Participants in the focus group were selected according to the following two criteria: (i) they had work experience of project planning and control in LNG construction; (ii) they had been involved in at least one LNG project in Australia in the last ten years. To allow interindividual variation within each group, within-group design was also applied (Schwartz and Meyer 2010). The first four columns on the left of Table 3-1 summarise the profile of the thirteen selected participants including their companies, expertise, and years of experience. Their expertise covers the LNG project life cycle, including design, procurement, logistics and supply chain, engineering and construction management, as well as maintenance. All industry experts had a minimum of 10-year experience in developing, delivering and managing LNG projects. It is therefore expected that these industry experts can offer a fair and useful recommendations to the development of the proposed TCM framework.

#### *Data Collection and Analysis*

At the beginning of the focus group study, the moderator described the purpose of the study, followed by the ground rules (e.g., equal status and voice of each participant; allowance to provide any suggestions, objections, and doubts freely), confidentiality of the discussion, and self-introductions. The ground rules and confidentiality agreements aimed to mitigate the effect of groupthink in the discussion process (Leung and Chan 2011). Data was collected by (1) voice recorder, (2) worksheets, and (3) white board (for discussion notes taking) in order to ensure the reliability of the data.

An initial TCM framework developed from the literature review was presented to the group firstly by the moderator. Then, the participants wrote down their personal views on the worksheet based on their experiences. These worksheets were collected and analysed through *Semantical Content Analysis* method which seeks to classify signs according to their meanings. The data was summarised into tables by keywords and phrase identifications. The right-most column of Table 3-1 shows their contributions in terms of the framework



development. From the various aspects of *Constraints* and *Constraint Management* identified in this exercise, participants further discussed how those aspects would shape the initial TCM framework. Following each discussion, the moderator asked the participants for any further suggestions within or outside those aspects. The final version of the framework is explained in Chapter 4.

Table 3-1: Profile of the Thirteen Industry Experts and Their Contribution

No.	Organisation (types)	Expertise	Years of experience	Main Contribution
1		Construction Management	20+	Long-lead constraints management
2	Woodside (Client)	Logistics and Supply Chain	20+	Supply chain constraint monitoring
3		Turnaround Maintenance	15+	Long-lead constraints identification
4	WorleyParsons (Engineering, Procurement and Construction)	Engineering Management and Logistics Supply Chain	10+	Engineering constraint monitoring Alignment between procurement and construction
5			10+	
6	Monadelphous (Construction and Maintenance)	Construction Management	15+	Constraint identification for safety and permits
7		Site Logistics	10+	Material constraint tracking
8	Track'em (Software)	Supply Chain Management	10+	Supply chain constraint monitoring
9		Engineering Design	20+	Maturity index development for engineering constraint
10	AVEVA (Software)	Construction Management and Procurement	10+	Alignment of removal plans among engineering, supply-chain and site constraints
10	Fremantle Steel (Manufacturer)	Offsite Fabrication	20+	Constraint modelling for offsite fabrication
11	KAEFER (Contractor)	Construction Management	15+	Constraint management for temporary structures
12	Bentley (Software)	Construction Management	15+	Site constraint monitoring
13	SECORA (Lean Consultancy)	Lean Construction	10+	Pull planning

## (2) Focus Group Study 2 & 3

### *Participants*

The aim of these two focus group studies are to facilitate the development of a coordinated approach for supply-chain constraint tracking (Objective 4). More specifically, *Focus Group Study 2* was for the development of the total supply chain process in LNG construction, while *Focus Group Study 3* was for the selection of the alternative tracking technologies to improve the visibility of the supply chain process. To decrease dominant voices, homogenous

participants were invited to the two focus groups according to their stakeholder status (Smithson, 2000). Five industry experts were invited to participate *Focus Group Study 2*, who were from five different companies. The majority of participants were middle aged (40% aged 30–39; 40% aged 40–49, and 20% aged  $\geq 50$ ), had amassed certain years' experience in LNG construction and/or supply-chain management (20% with 3–5 years; 60% with 5–10 years; and 20% with >10 years), and currently held senior positions (40% were construction managers; 20% were site managers; 20% were supply-chain managers; and 20% were project managers).

*Focus Group Study 3* involved seven people. Two of them were from *Focus Group Study 2* and another five from five different tracking solution providers, respectively. The majority of participants were middle aged (14% aged 20–29; 43% aged 30–39; 29% aged 40–49, and 14% aged  $\geq 50$ ), had amassed certain years' experience in LNG construction and/or tracking technologies (29% with 3–5 years; and 43% with 5–10 years; and 28% with >10 years), and currently held senior positions (14% were construction managers; 14% were site managers; and 72% were business development managers).

#### *Data Collection and Analysis*

The process at the beginning of *Focus Group Study 2 and 3* was same as *Focus Group Study 1*. The moderator described the purpose of the study, followed by the ground rules, confidentiality of the discussion, and self-introductions. Data was collected by (1) voice recorder, (2) worksheets, and (3) white board.

For *Focus Group Study 2*, A draft version of the total supply chain process map was firstly introduced, which was developed by the author based on the previous literatures. Then a series of short questions were asked to check the reasonability and authenticity of the proposed process map. During the discussion, the owner pointed out that there were two different types of materials in LNG construction, namely general materials and project-specific materials, and each of them had different SCM strategies. The former included standard materials and tools; and the latter contained specified instruments and offsite fabricated modules. The logistics solution provider emphasized the shipping difference between the two delivery strategies: Free on Board (FOB) and Ex Works (EXW). Under the FOB agreement, there is no line item payment by the buyer for the cost of getting the goods onto the transport. EXW means that a buyer incurs the risks for bringing the goods to their final destination. The fabricator confirmed the process during fabrication, however, he emphasised that the process was not constant and would be adjusted based on client's requirement. For instance, surface treatment and/or pre-assembly were not always necessary for all productions. The general contractor pointed out

the difficulties of site logistics management, especially for warehouse management. The final version of the total supply chain process map is explained in Chapter 7.

For *Focus Group Study 3*, Seven types of tracking technologies were introduced and discussed at the beginning, namely barcode, passive RFID, active RFID, GPS, UWB, Wi-Fi, and Bluetooth. Due to the intrinsic safety requirement in LNG industry (pointed out by the client), the last three technologies (i.e. UWB, Wi-Fi, and Bluetooth) were excluded in the following discussion because they had not been certified so far against explosion protection concepts. Subsequently, the validated version of the total supply chain process for LNG construction which came from *Focus Group Study 2*, was introduced to the participants. For each detailed process, they needed to evaluate the feasibility of the four alternative tracking solutions (i.e. barcode, passive RFID, active RFID, and GPS). Five factors were considered during the evaluation: (1) the type of the object to be tracked; (2) indoor or outdoor environment; (3) line-of-sight requirement; (4) Location information requirement; and (5) Tag removal. Finally, suggested solutions were given in terms of their low complexity in practice and cost-effectiveness. The final tracking solution is explained in Chapter 7.

### **3.2.2 Experimental Research Method**

The experimental research method is a quantitative approach designed to discover the effects of presumed causes. The key feature of this approach is that one thing is deliberately varied to see what happens to something else, or to discover the effects of presumed causes. This approach can be used in both laboratory settings and field settings. A *Field Experiment* “is an experimental research study that is conducted in a real-life setting. The experimenter actively manipulates variables and carefully controls the influence of as many extraneous variables as the situation will permit”. A *Laboratory Experiment* “is a study that is conducted in the laboratory and in which the investigator precisely manipulates one or more variables and controls the influence of all or nearly all of the extraneous variables”.

The experimental approach has the primary advantage of being able to infer causal relationships. However, it is easier to identify causal description, which describes the consequences of deliberately varying a treatment, than it is to achieve a causal explanation, which clarifies the mechanisms by which a causal relationship holds. A second advantage of the experiment is that it controls for the influence of extraneous variables. Other advantages are that it permits the precise manipulation of one or more variables, produces lasting results, suggests new studies, and suggests solutions to practical problems. The experimental approach has the disadvantages of not being able to test for the effects of nonmanipulated variables, creating an artificial environment, and frequently being time consuming and difficult to design.

In a field setting, the author makes use of a real-life situation and thereby avoids criticism for having created an artificial environment. Typically, however, there is not as much control over extraneous variables. In a laboratory setting, the experimenter brings the participants into the laboratory, where there is maximum control over extraneous variables; however, this usually means creating an artificial environment.

Two Laboratory Experiments and two Field Experiments had been conducted to validate the approaches proposed in this thesis. More specifically, *Laboratory Experiment 1* was to evaluate the performance of the proposed DNA-based constraint modelling method in LNG construction; *Laboratory Experiment 2* was to evaluate the performance of the proposed TCM method. *Field Experiment 1 and 2* was to validate the effectiveness and efficiency of the selected tracking technologies (i.e. barcode for offsite fabrication tracking, GPS for shipping and delivery tracking, and Active RFID for construction site logistics tracking).

### **(1) Laboratory Experiment**

The two Laboratory Experiments were conducted based on a *LNG Construction Simulation Game*. Game-based experiments (Camerer and Fehr 2004) had been widely used to set up situations for strategic interaction and test many of the fundamental assumptions of construction management theory such as lean and pull planning. Most games involve anonymous agents, physical tools, real small-scale buildings (made by woods or plastics), and paper-based instructions or drawings. Players cannot communicate with each other unless allowed. Conventions often favour minimal and vague description of the game to the subjects when recruited, the use of private spaces where the game is explained with a standard script, the inclusion of a question and answer session and sometimes a test is administered to ensure subjects understand the game (Jackson 2011). In the game the players make choices according to the information they have in their hands such as construction progress, resource constraints, and permit issues.

Tommelein et al. (1999) used a Parade Game to evaluate the impact of work flow variability on trade performance. The game consists of simulating a construction process in which resources produced by one trade are prerequisite to work performed by the next trade. Perng et al. (2006) utilised a Bidding Game to explore the bidding situation for economically most advantageous tender projects. 24 participants played the game and the results revealed that the game had the potential to identify important factors in the bidding situation, simulate competitive bidding behaviours, and explore competitive advantages in the bidding process. Sacks and Goldin (2007) and Sacks et al. (2007) had successfully tested lean construction concepts on high-rise apartment buildings through a lean simulation game named LEAPCON.

Van-den-Berg et al. (2017) developed a serious gaming approach and applied it to train students to learn how to improve the performance of a construction supply chain.

*LNG Construction Simulation Game*

This is a pre-existing game that is used to demonstrate LNG construction process including procurement and supply chain. Construction works within this game include: site preparation, module installation (the modules are manufactured off-site), pipework installation, wiring installation, and major equipment installation. Figure 3-2 illustrates the detailed construction work flows. Engineering constraints in this game include engineering drawings and instructions (as shown in Figure 3-3); Supply-chain constraints include materials, instruments, and off-site fabricated modules (as shown in Figure 3-4); and Site constraints include tools, preceding works, permits, work space, workforce, and safety (as shown in Figure 3-5). Table 3-2 shows the number of people and roles needed to play the game.

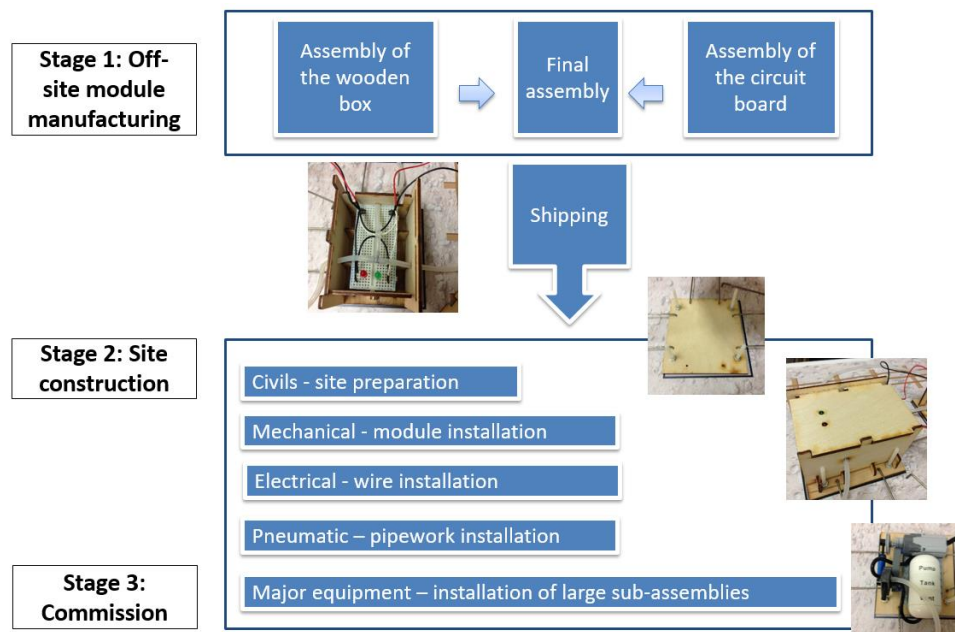

Figure 3-2: Construction Work Flows of the LNG Construction Simulation Game

**VALVE**  
LIQUID NATURAL GAS COMPRESSION

**Engineering Instruction**

Part Name: **Compressor**

Area: Site: Written by: T Gascoigne Date: 25/06/2010

Step Number	Process Instruction	Time
1	Select Correct parts	
2	Place on correct base	
3	Assemble to drawing	

**Parts List**  
Compressor x 1

Engineering Drawing

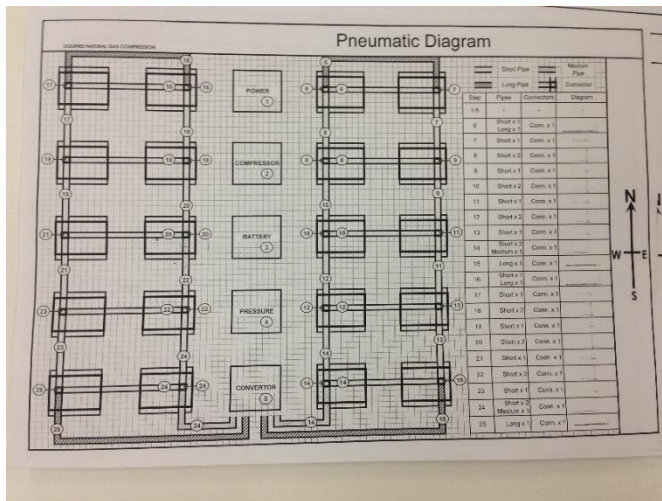



Figure 3-3: Engineering Drawings and Instructions



Figure 3-4: Materials, Instruments, and Off-site Fabricated Modules



Figure 3-5: Construction Site of the Game



Table 3-2: The Roles of the People in the LNG Construction Simulation Game

Roles	Quantity
Project Manager	1
Plant Manager	1
Engineering Manager	1
Procurement Manager	1
Site Manager	1
Module Manufacturing	6
Civils Contractor	2
Mechanical Contractor	1
Pneumatic Contractor	2
Electrical Contractor	1
Major Equipment Installation	1
Shipping	1
Commissioning	1
Total	20

### *Participants*

Theoretically, a large enough random sample of males and females provides the best basis for generalising results over the general population and avoiding a gender bias (Järvelä 2014). However, in practice this goal is often problematic to achieve. Although many women study construction management courses and work for LNG construction, male population still accounts for the vast majority. Therefore, acquiring comparable numbers of experiment participants of both genders with good sample size can sometimes be difficult. Similarly, it is hard to conduct an experimental study that would have enough participants in each age group to provide statistically significant results without limiting the amount of relevant variables through participant selection. Instead, these factors have to be taken into account when analysing the data, interpreting the results, and generalising them (Järvelä 2014).

For *Laboratory Experiment 1*, the aim is to evaluate the performance of the proposed DNA-based constraint modelling method in LNG construction. Therefore, participants with basic construction management knowledge are required. 20 students from a construction management course were randomly selected based on their Student Identifications. The majority of participants were male and around 20 years old (75% male and 25% female).

For *Laboratory Experiment 2*, the aim is to evaluate the performance improvement of the

proposed TCM method compared with conventional approach. Therefore, two groups are needed. All the 40 participants were graduate students (i.e. same knowledge level) and had very limited knowledge on lean and TCM. Meanwhile, there were both male and female subjects (82.5% male and 17.5% female), which aligned to the real project team. The participants were randomly split into two groups: Group A with TCM implementation and Group B without. In order to reduce the learning curve issues, there was a basic training session (30 minutes) for both groups, and they were also guided to play once before starting the test. Two additional players were assigned to represent the clients of the LNG project. One selected design variations at regular time intervals through the game and delivered them to the project manager; the other checked completed tasks and issued permits to site managers.

#### *Data Collection and Analysis*

The raw experimental data was collected by (1) video recorders, and (2) predefined worksheets (i.e. module quality reports, progress reports, and commissioning reports). These data were then processed for further statistical analysis and interpretation based on predefined indicators. In *Laboratory Experiment 1*, five indicators were developed to analyse the performance of constraint removal during the experiment, such as Number of Unconnected Components at time  $i$  (NUCi), Variance of Constraint Removal at time  $i$  (VCRi), Variance of IWP Released to Site at time  $i$  (VIRSi), Out-Degree of a Constraint Node (ODCN), and In-Degree of a CWP/IWP Node (IDCN/IDIN). Detailed explanation of each indicator, experiment design, and experiment results can be found at Chapter 5.

In *Laboratory Experiment 2*, indicator of Cumulative Progress (CP) was developed to measure the actual progress at the end of each time interval; and productivity indicator was defined to measure the performance of each construction trade. Other indicators such as the number of defective LNG modules, and actual duration were also defined and calculated. Detailed explanation of each indicator, experiment design, and experiment results can be found at Chapter 8.

## **(2) Field Experiment**

*Field Experiment 1* was conducted at a real fabrication facility owned by Fremantle Steel Group. Barcode technology was deployed to a small batch of products to track its fabrication processes including cutting, drilling, assembly, welding, surface treatment, pre-assembly, and despatch. *Field Experiment 2* was conducted at a real LNG plant facility owned by the Australian Centre for Energy and Process Training (ACEPT). GPS and Active RFID were deployed to track the shipping process and construction site logistics, respectively. Detailed experiment design of these two field experiments are explained in Section 7.4, Chapter 7.

### *Data Collection*

Two types of data were collected during the two experiments. The first one was the sensor data. In *Field Experiment 1*, Barcodes were scanned manually by workers as required and uploaded to a 3D-based data platform which was developed by the researcher. In *Field Experiment 2*, GPS tags were read by the satellite (i.e. no human needed). Active RFID tags were read by the fixed readers installed on the test bed. Data from GPS and RFID were also sent to the 3D-based data platform for data integration and visualisation. The second type of data was secondary data that collected from Fremantle Steel Group and ACEPT. These data included historical fabrication data (i.e. time spent for generating progress reports, time spent for progress checking, time spent for locating missing components, etc.), norms, site maps, and facility details.

### *Data Analysis*

For *Field Experiment 1*, the secondary data such as site maps and facility details were interpreted by the researcher so as to design an overall tracking scenario. Data generated from barcodes included the scanned time and locations. The location data was firstly transformed to the status of each tracked object such as “in cutting and drilling”. Then, the status information together with the scanned time were transformed to progress information. Finally, Microsoft Project tool was utilised to generate S-Curves (i.e. accumulated progress curves with normal distribution) for project progress monitoring and measurement. The efficiency of the barcode-based fabrication tracking solution was measured based on the time and cost reduction analysis compared with historical project information.

For *Field Experiment 2*, RFID signals were received by the four Fixed RFID Readers at a predefined period. The locations of these RFID tags were determined through triangulation calculations. In order to assess the accuracy of the active RFID system, a performance analysis of the RFID tags localisation was conducted. Given that the magnitude of Radio Signal Strength (RSS) was related to the distance between reader and tag, the researcher first validated the relationship of RSS between each RFID tags in the simulated LNG plant construction environment. Two randomly selected RFID tags were put at the same position on a trolley located within the detection range of the four fixed readers. The results showed that the RSS distributions of the dynamic cases were more fluctuated than that of the static cases. However, both tags at the same place responded different RSS values but the patterns of changes were similar with each other. It suggested that there was a relationship between RSS responses and the distances of RFID tags, which could be utilised to further improve measurements as long as it could be formed. Once the tags with known locations were obtained as reference tags, the

measured location of the target tag was calibrated by the RSS responses from those tags through the determined relationship.

### 3.2.3 Linked Data Development Method

Figure 3-6 shows the research steps and methods implemented for developing the linked data-enabled cross-domain constraint information sharing platform. Linked data is the core technique to break down the constraint information silos that exist between various formats and brings down the fences between various sources. The detailed research steps and related research methods are explained as follows.

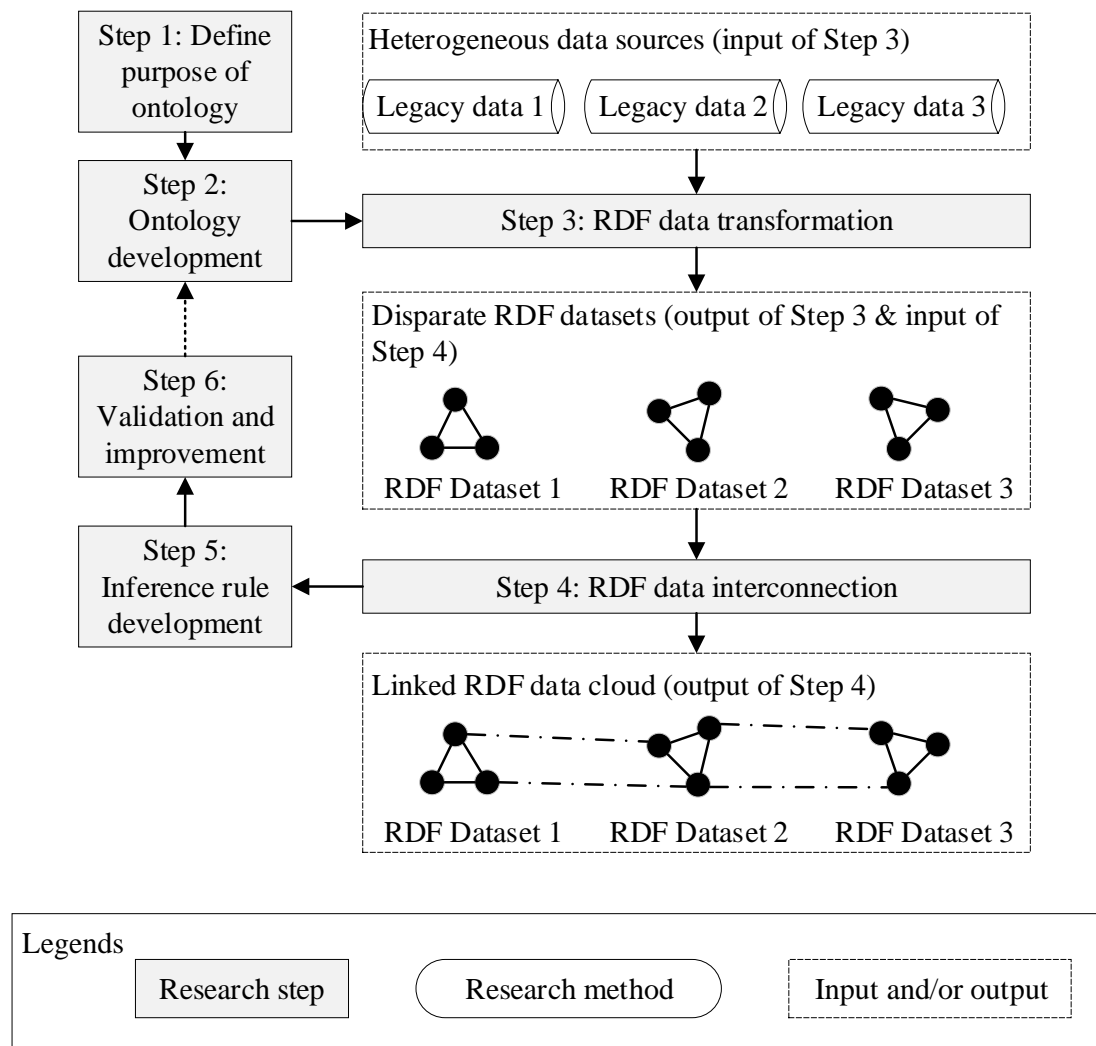

Figure 3-6: Linked Data Development Method

#### *Step 1: Defining Purpose of Ontology*

In this step, the researcher clearly defined two purposes of the ontology: (i) to formalise the constraint knowledge; (ii) to support data wrapper (i.e. RDFisation process) and publication

for existing legacy data. In addition, the scope of the ontologies covered domains of LNG project planning, engineering, supply chain, and construction.

#### *Step 2: Developing Ontology*

The ontology development method deployed in this study was derived from the method developed by Noy and McGuinness (2001), which includes the following five steps: (1) Determine the domain and scope of the ontology; (2) Enumerate important terms in the ontology; (3) Define the classes and the class hierarchy; (4) Define the properties of the classes; and (5) Define the facets of the properties.

Two types of ontologies were developed: constraint ontology and AWP ontology. The knowledge sources considered for identifying relevant concepts and coding the two ontologies include the ISO 15926 standard (Fiatech 2011), Project Management Body of Knowledge (PMI 1987), AWP implementation guidance (CII 2013), WFP execution manual (PMP 2009), and LPS specifications (Ballard 2000). A Description Logic (DL) reasoner was conducted to check the consistency of the proposed ontologies.

Reuse of existing vocabularies or ontologies was highly recommended in this study. Existing ontologies, such as the Reference Data Library (ISO 2007) presented in ISO 15926-Part 4, was reused to describe the engineering constraints. Existing vocabularies, such as FOAF (Brickley and Miller 2007) and Dublin Core (Initiative 2004) were reused to define the people and organisations involved in a LNG project and basic constraint information, respectively.

#### *Step 3: Developing RDF Data Transformation Method*

The method of RDF data transformation was used to convert the existing legacy data (i.e. engineering constraint data, supply chain constraint data, site constraint data, and project planning data) to RDF data. In LNG industry, the legacy data is normally stored in three types: (1) Drawing data, such as Piping and Instruments Diagram, and Isometric drawings; (2) Tabular data, such as spreadsheets and relational databases; and (3) Raw document data, such as Microsoft Word, Adobe PDF, and Image. Accordingly, three types of RDF data transformation methods were developed, namely, *Drawing data to RDF*, *Table data to RDF*, and *Document Meta-data to RDF*.

#### *Step 4: Developing RDF Datasets Interconnection Method*

The result of the *Step 3* was a set of disparate RDF datasets. To fully support the decision making, these disparate resources were required to be interconnected to each other. The objective of this step is to create a global, interconnected data space for cross-domain constraint information sharing and management. Two types of data interconnections were

developed, namely, *data interconnection among RDF datasets* and *data interconnection between RDF datasets and documents*.

#### *Step 5: Inference Rule Development*

Inference is the process of discovering new facts from existing triples on a set of rules. There were two types of rules utilised in this study. The first one was the standard ruleset which included *rdfs*, *rdfs+* and *OWL-Horst*. The second one was the pre-defined rulesets created by users. New facts could be added to the RDF triple store through forward-chaining inference, or be inferred at query time through backward chaining inference (Kiryakov et al. 2009, Kolovski et al. 2010, Meditskos and Bassiliades 2010).

#### Step 6: Validation and Improvement

A prototype of the proposed approach was developed to demonstrate its capabilities in cross-domain constraint information sharing. A pilot case study was conducted to test the effectiveness and efficiency of the prototype. Detailed information in terms of case background, data preparation and processing, and evaluation method can be found in Section 6.6, Chapter 6. Feedbacks from the testing results then went back to *Step 2* to make continues improvement.

### **3.3 Conclusions**

This chapter examined the research methodology used in the thesis. The first section discussed the research philosophy within which the researcher has undertaken the research. The research's positivism stance was shown as partly determining the mixed research methods (i.e. qualitative and quantitative approaches) to the study. The second section explained the reason why choose Focus Group Study and Experimental Research Method as the main research methods in this thesis. In addition, participant selection, data collection and analysis, and limitations for each method were also discussed. This chapter also included a sub-section on the issues of linked data development.

## **Chapter 4: A Hierarchical Constraint Management Process to Identify and Remove Constraints through Project Life Cycles**

### **4.1 Introduction**

Chapter 4 proposes a hierarchical constraint management process (i.e. *Research Objective 1*), which consists of three levels of loops: Loop 1 happens in project stage one and involves modules of constraint modelling and monitoring at CWA level; Loop 2 happens in project stage two and involves modules of constraint modelling, monitoring, and removal at CWP level; and Loop 3 happens in project stage three and involves modules of constraint modelling, monitoring, and removal at IWP level. In addition, how to align this hierarchical constraint management process to a project's different stages (i.e. preliminary planning, detailed engineering, construction, and commissioning) is also discussed. *Focus Group Study 1* explained in Section 3.2.1, Chapter 3 was the main method used to develop the hierarchical constraint management process.

### **4.2 Framework of the Hierarchical Constraint Management Process**

This section describes a framework of the hierarchical constraint management process which aims to identify and remove constraints through project life cycles. During the review stage of the proposed framework by the selected industry experts, the client and manufacturer pointed out that there were two different types of constraints in LNG construction, namely long-lead and short-lead constraints, which needed to be distinguished. For instance, most of the project-specified instruments were long-lead constraints because they were needed to be designed and fabricated overseas which took a long time to deliver. Standard materials and tools such as valves and bolts, could be short-lead constraints if they are available in local market. There should be different management strategies to handle these two types of constraints. People from engineering company emphasized the alignment among engineering, procurement and construction plans. In addition, they mentioned constraint-removal plan should be developed from a construction-centred perspective. The contractor highlighted the importance of identifying other long lead-time constraints like safety and permits, because there were more rigorous standards in LNG industry. The delay of temporary structures was another type of constraint identified by the sub-contractor, which had a big negative impact on construction work flow. The lean consultancy confirmed the AWP process, however, he emphasized that the process was not constant and would be adjusted based on client's requirement.

Figure 4-1 shows the final version of the proposed hierarchical constraint management process. In the left part, AWP method is selected as a basis to express the work flow of the project

execution in LNG industry. The underlying reasons are threefold: (1) AWP method is developed from and increasingly used in oil and gas industry when compared with LPS (Hamdi 2013); (2) AWP method is an extension of WFP which covers both construction and initial early stages of projects (CII 2013); (3) AWP is an overall process flow of all the detailed work packages (CWPs, EWPs, and IWPs), which is more close to the current practice of LNG construction (confirmed by the thirteen industry experts). Three stages are defined within the work flow: preliminary planning, detailed engineering, and construction. The right part of Figure 4-1 shows a general constraint management process, which can be further classified into three modules: constraint modelling, constraint monitoring, and constraint removal. The level of detail of each module depends on the project stages. For instance, in detailed engineering stage, the level of detail of all the three modules is in CWP level. There are three levels (i.e. levels of CWA, CWP, and IWP) of loops existed between the project stages and the core modules. Each of them is explained in detail as follows.

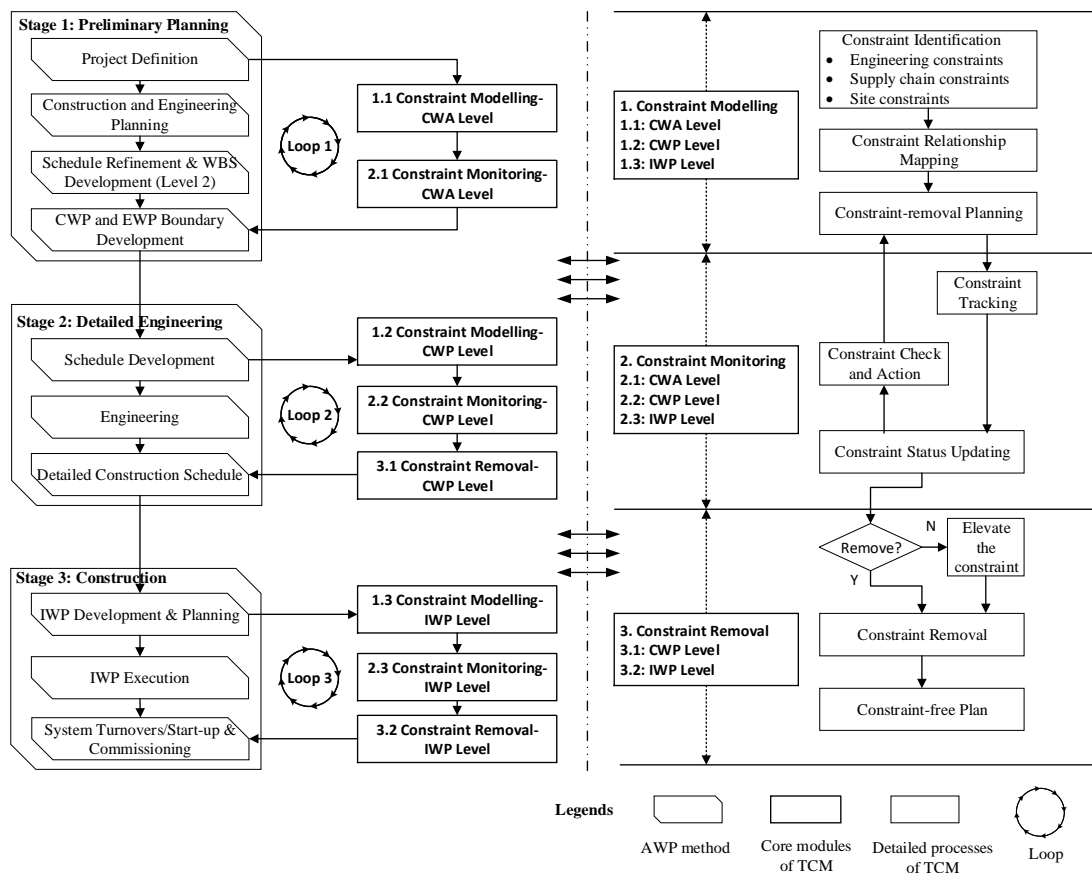

Figure 4-1: A Hierarchical Constraint Management Process



#### **4.2.1 Constraint modelling**

Constraint modelling is key to allow project managers and engaged partners to have a thorough understanding of interconnections among activities. There are three processes within this module. The first one is constraint identification which needs to accurately detect all the constraints. The traditional process for constraint identification always happens once and close to the construction stage, and only important constraints are taken into consideration, such as material, workforce, and equipment. In order to assure a full constraint identification, constraints in LNG construction are classified into three main categories (as shown in Figure 4-2): engineering, supply chain, and site constraints. Constraints such as incomplete drawings, lack of assembly specifications and 3D models are engineering constraints, which decide the start time of procurement, fabrication and site installation. Supply chain constraints include the late procurement of bulk materials and project-specific instruments and equipment. Without timely purchasing and delivering these resources to the site, detailed construction activities cannot be planned and executed. Site constraints contain the shortage of workforce, lack of temporary structures, limited work space, uncompleted preceding works, bad weather, lack of work permits, and safety issues. If these site constraints are not timely removed, construction work crews cannot perform their daily tasks. The underlying reasons for this type of classification are twofold: (1) most of LNG project are delivered by the strategy of Engineering Procurement and Construction (EPC), hence, it is easy to conduct constraint identification; and (2) work packages are widely used in LNG construction, such as EWP, CWP, IWP, Procurement Work Package (PWP), inspection work package and commissioning work package. Therefore, it is easy to manage these constraints.

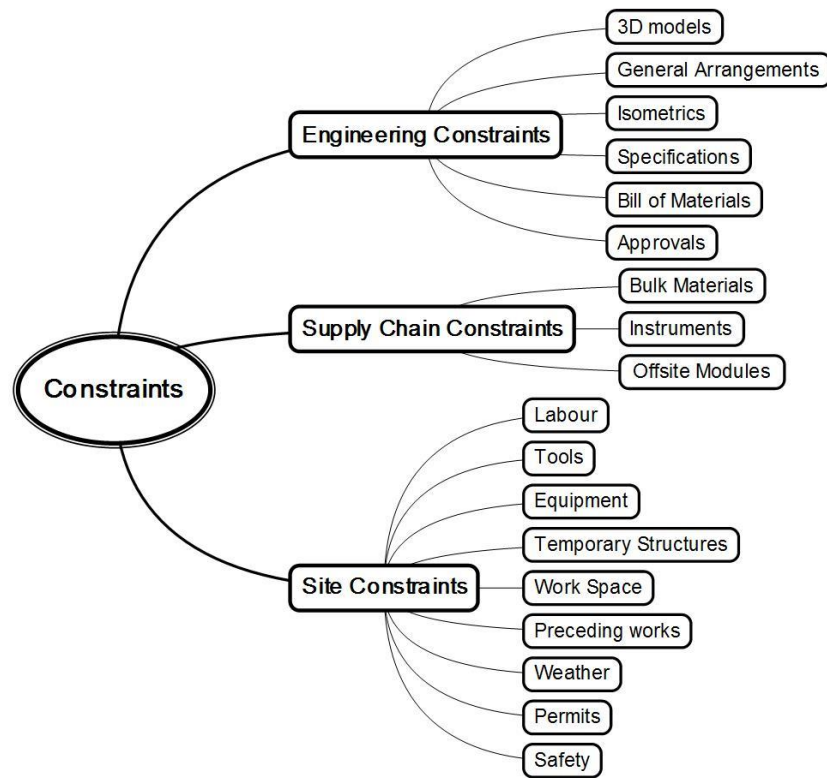

Figure 4-2: Constraint Classification

The second process is constraint relationship mapping. In real project situation, constraints are not independent and have inter-relationships among each other. Hence, having a thorough understanding of these relationships is very helpful for removing constraint in time. Figure 4-3 shows a single example which contains only one EWP, one PWP, one CWP and one IWP. When the designers start to develop EWP, initial vendor data to perform detailed design needs to be obtained, final vendor data is then needed to conduct production design, final approvals from the client are necessary to release the EWP to construction. An interesting finding is that both the two types of vendor data come from PWP, and the development of the PWP needs to rely on conceptual design outputs which come from the EWP. Therefore, any delay of the activities within the two work packages will result in late constraint removal, thus causing whole project delay. From the IWP perspective, before released to the site, it needs to satisfy all the different types of constraints including site constraints and constraints from EWP, CWP, and PWP.

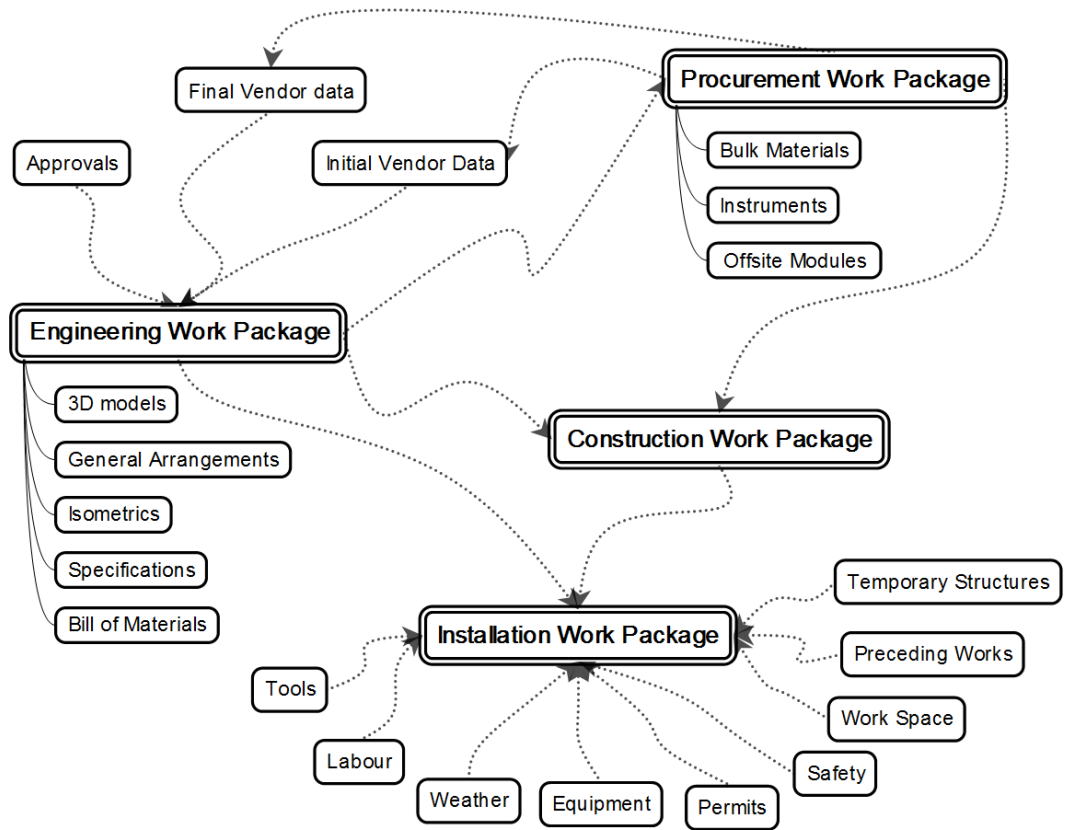

Figure 4-3: A Simple Example of Constraint Relationship Mapping

The last process is constraint-removal planning. In order to assure all the constraints are timely removed, a detailed timeline for each constraint removal is needed to be pre-planned while considering the requirement of project completion. The pull-driven approach is applied to determine the deadline of each constraint. For example, when the sequence of the CWPs are decided and agreed by all project stakeholders, the planning of EWP and PWP should be aligned with the CWPs. In addition, each deliverable from EWP or PWP must be early defined and communicated so that engineering or procurement can be proceeded with a clear understanding of the level of detail.

#### 4.2.2 Constraint monitoring

In a real LNG construction situation, the statuses of constraints change over time. The latest constraint information is important for project managers to assess progress and release constraint-free work packages. When project suffers delay, the up-to-date status of constraints can also be used as references for decision-making. There are three processes within the module of constraint monitoring. The first one is constraint tracking which focuses on tracking each individual constraint. The approaches for constraint tracking can be automated, semi-automated or manually which depend on project requirement and technology maturity. For

example, material constraints can be automated tracked by RFID (Navon and Berkovich 2006), while safety constraints maybe still need to be manually checked by site workers.

The second process is constraint status updating which focuses on calculating the maturity of a task or a work package. The maturity index is intended to support both short-term decision making by team leaders, before they commit to performing tasks, and also to support weekly-planning activities (Sacks et al. 2010). All the tracking data from the first sub-step are collected for the maturity index calculation. Table 4-1 shows an example of maturity index for a piping EWP.

Table 4-1: An Example of Maturity Index for A Piping EWP

<b>Tasks</b>	<b>Maturity (%)</b>
EWP identified and mapped to CWP	5
Initial scope identified (line numbers)	20
Preliminary equipment data received	25
Initial routing of lines established	45
Initial bulk material to supply chain	55
Piping studies received for critical lines	60
Final vendor data received	70
Final routings completed	75
Process and Instrumentation Diagrams and Line Designation Table issued for construction	80
Stress analysis for large bore completed	85
Bill of Materials completed	90
EWP complete with all drawings/specs issued for construction	95
EWP accepted by Construction	100

The final process within this module is constraint checking and action, which is focused on comparing as-actual constraint status with an as-planned constraint-removal plan. The frequency of constraint checking is dependent on the project stages and characteristics. For example, the frequency can be quarterly or monthly at project early stage, and then change to weekly or daily at construction stage. Different action strategies should be performed

according to the checking results. If the results indicate several delays of constraint removal, catch up action needs to be conducted.

#### **4.2.3 Constraint removal**

Constraint removal is mainly executed in the stage of look-ahead planning. Constraints cannot be removed unless either of the following two conditions is satisfied: (1) the maturity index of the constraint is 100%; or (2) the maturity index can be updated to 100% based on forecasting or reliable commitment.

#### **4.2.4 Loop 1 (CWA Level)**

Loop 1 happens in project stage one and involves the modules of constraint modelling and monitoring at CWA level. CWAs are manageable areas from a large project, and are developed according to the path of construction and requirement of integrated planning. The main objective of loop 1 is to identify and monitor long lead-time constraints and align engineering and procurement plans to the construction plan. In project definition phase, it is important for design engineers to embrace a total project view in order to position the project for effective implementation of TCM. In construction and engineering planning phase, construction planning is key to establishing alignment with engineering. The sequence of construction activities should be established so as to ensure that engineering can sequence its work to support construction. This allows construction to drive the engineering plan which can realize the greatest potential of TCM to manage engineering constraints. The constraints of temporary structures (e.g. site traffic flow, temporary roads, general parking, laydown areas, site security, subassembly areas, field office locations, offsite storage, and the related power, water and air requirement) should be identified and well managed because they can affect construction work flow. Engineering plan is developed based on the sequence of construction, and engineering feedbacks are also needed to refine the sequence. All major constraints should be addressed at this point, including any resulting from the contracting and procurement plan. In schedule refinement phase, key long lead-time constraints of the supply chain should be identified and scheduled based on procurement expertise. In CWP and EWP boundary development phase, a list of deliverables for CWP and EWP has been developed. Constraints of labour and materials should be considered. Identifying at a high level the necessary workforce by discipline, including support craft services for each CWP, and then assessing the availability of these resources are key in this phase. The material requirement should be estimated based on material specification from engineering, and unique and/or long-lead material items should be identified, such as certain alloy piping materials and many process equipment items.

#### **4.2.5 Loop 2 (CWP Level)**

Loop 2 happens in project stage two and involves all the three modules of constraint modelling, monitoring, and removal at CWP level. A CWP defines a logical and manageable division of work within the construction scope and is typically aligned with a bid package. A typical CWP includes schedule, budget, environment requirements, quality requirements, and special resource requirements. The objective of loop 2 is to manage constraints from a CWP-centred perspective, and continually involve owner, engineers, purchasers and contractors to find new constraints and detect potential constraint-removal issues. Monitoring and removing constraints of engineering and long-lead supply chain should be given high priorities in this loop. During the schedule development phase, detailed resource constraints should be considered with progressing for work packaging. There must be alignment with areas that plan to have an early start-up. Owner operations requirement should also be accommodated in this phase. In engineering phase, all engineering deliverables (i.e. engineering constraints for CWPs) need to be clearly mapped to EWPs and CWPs. Changes need to be managed to assess their impact on CWPs. In the detailed construction schedule phase, site constraints must be considered and reflected in the constraint relationship map.

#### **4.2.6 Loop 3 (IWP Level)**

Loop 3 happens in project stage three and involves all the three main modules within TCM at IWP level. An IWP is a deliverable that enables a construction work crew to perform work in a safe, predictable, measurable, and efficient manner. The objective of loop 3 is to maintain, monitor and remove constraints from an IWP-centred perspective based on IWP look-ahead schedule. Modelling, monitoring, and removal of detailed site constraints such as materials, equipment, tools, labour, safety, permits, weather and work space are the focus of this loop. Once the IWP scope is identified, a rough schedule and sequence can be developed. Foremen should be notified of the requirement to support this initial plan. After the initial allocations have been made, constraints should be monitored on the basis of the constraint-removal plan. All the related constraints of an IWP should be removed prior to release the IWP to the field. Once issued, the superintendent should review and coordinate the execution of the work with the general foreman, foreman, and craft. The superintendent, with support from the project planner, is responsible for follow-up on the execution and progress of the IWP. After IWP closeout, the project team should continue to improve TCM process by looking for ways to increase accuracy, reduce information collection errors and redundancy, and develop a specific continuous improvement/best practices plan to implement TCM in practice.

### **4.3 Conclusions**

A hierarchical constraint management process with three levels (i.e. Levels of CWA, CWP, and AWP) had been developed in this chapter through literature reviews and a focus group study. The constraint management process at CWA level (i.e. Loop 1) aims to identify and monitor constraints that have a long lead time and align engineering and procurement plans to the construction plan; The constraint management process at CWP level (i.e. Loop 2) aims to manage constraints from a construction-centred perspective, and continually involve owner, engineers, purchasers and contractors to find new constraints and detect potential constraint-removal issues; and The constraint management process at IWP level (i.e. Loop 3) is to maintain, monitor and remove constraints from an installation-centred perspective.

## **Chapter 5: DNA for Constraint Modelling and Management in LNG Construction**

### **5.1 Introduction**

Chapter 5 develops a network-based method for constraint modelling and analysis by leveraging the DNA technique (i.e. *Research Objective 2*). DNA varies from traditional social network analysis, and can handle large, dynamic, multi-mode, multi-link, and multi-level networks with varying levels of uncertainty. The DNA technique provides a promising way to understand the complex interactions within a constraint network which includes a variety of nodes and relations, such as people, work packages, and constraints. Equipped with time-dimensional analysis and complex modelling capabilities, DNA can efficiently detect conflicts between construction plans and constraint-removal plans, and dynamically identify critical constraints before and/or during project execution. A laboratory experiment (i.e. *Laboratory Experiment 1* explained in Section 3.2.2, Chapter 3) was developed to demonstrate and evaluate the proposed method. The results show that DNA can significantly improve the performance of constraint modelling and removal, which in turn increase construction workflow and productivity.

### **5.2 Meta-network for Constraint Modelling**

A meta-network is a multi-node, multi-link, multi-level network. Figure 5-1 shows an example of constraint meta-network in LNG construction. From the network, multi-node (e.g., agents, work packages and constraints) and multi-link (e.g., superintendent, hierarchy, sequence and constraint) can be found. Multi-level is another dimension, which describes the hierarchy of nodes, for instance, the nodes of CWP contains two IWP nodes (i.e. IWP 1 and 2). With agents, constraints, and work packages involved, constraint meta-network can effectively present and analyse the dynamic evolution process as project progresses.

For analysing project constraints evolution, the meta-network possesses two unique attributes that distinguish DNA from other network analysis methods such as SNA. The first one is the dynamic property which enables the meta-network to adapt easily to constraint updating and removal. When the statuses of constraints are updated, the nodes in the meta-network will be changed accordingly so as to reflect the latest project situation. Similarly, the links between any two nodes can be restructured, revised, or removed (Li et al. 2015). All of these changes trigger the evolution of a sub-network, or even a whole new meta-network (Li et al. 2015). The second one is the complex attribute which is embodied in network structure and connections. Multiple types of nodes and their sub-nodes are identified and incorporated into



the meta-network, which increases its structural complex. In addition, a network connection between two nodes can be probabilistic, directed and undirected. For example, whether a constraint can be removed or not depends on its maturity index which is a measure of the degree to which the constraints on work have been removed (Sacks et al. 2010). Therefore, the weight of constraint-link can be used to reflect the maturity of the constraint. Meanwhile, connections could be either one way, such as a sequence-link for CWPs or IWPs, or two way, such as engineering information exchange between EWP and PWP.

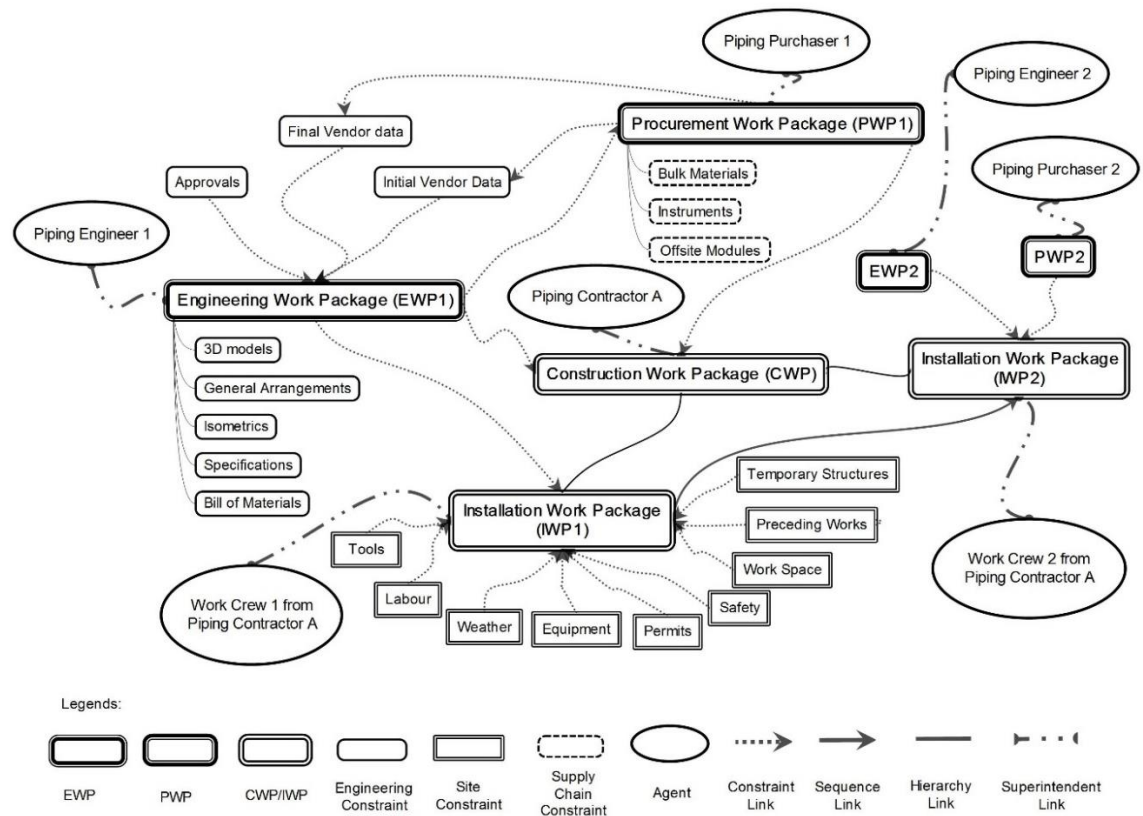

Figure 5-1: An Example of Constraint Network in LNG Construction

The pluralities of both network nodes and connections elevate the complexity of the system exponentially and make the effects of a meta-network far beyond the capacity of conventional network analysis (Li et al. 2015). A constraint network in LNG construction (as shown in Figure 5-1), which has many dynamic and complex characteristics, is an appropriate example of a meta-network. Meta-networks can be simply expressed by the meta-matrix, which describes the nodes and their connecting links (Carley 2003, Li et al. 2015). Table 5-1 presents a meta-matrix for constraint network in LNG construction, which includes five different types of nodes: agents, CWP/AWPs, engineering constraints, supply chain constraints and site constraints. Fifteen inter-linked networks (also called sub-networks) are also defined based on the interactions among these nodes, such as Construction Assignment Network, Engineering

Constraint Network and Site Demand Network. Changes in one network cascade into changes in the others, and relationships in one network imply relationships in another (Carley et al. 2007, Li et al. 2015). For example, once a small change occurs in the Construction Precedence Network (CPN), the Engineering Precedence Network (EPN), Supply Chain Precedence Network (SCPN) and Site Precedence Network (SPN) will have ripple effects.

Table 5-1: Meta-Matrix for Constraint Network

Nodes	Agents	CWP/IWPs	Engineering Constraints	Supply Chain Constraints	Site Constraints
Agents	Social Network (SN)	Construction Assignment Network (CAN)	Engineering Management Network (EMN)	Supply-Chain Management Network (SCMN)	Site Management Network (SMN)
CWP/IWPs		Construction Precedence Network (CPN)	Engineering Constraint Network (ECN)	Supply Chain Constraint Network (SCCN)	Site Constraint Network (SCN)
Engineering Constraints			Engineering Precedence Network (EPN)	Interdependence Network (IN)	Change Management Network (CMN)
Supply Chain Constraints				Supply Chain Precedence Network (SCPN)	Site Demand Network (SDN)
Site Constraints					Site Precedence Network (SPN)

In the LNG construction practices, numerous constraints identified in Section 3 frequently interact with each other and any delays of constraint removal results in schedule and cost overruns. Meanwhile, the continuous emergence of design and construction changes, as well as additional or restructured project teams, is common in LNG construction projects and

requires dynamic network change. Therefore, it is necessary and essential to use DNA to improve the constraint management in terms of its complexity and dynamic characteristics.

### 5.3 A Framework of DNA for Constraint Management

This section describes a framework of DNA for constraint management in LNG construction (as shown in Figure 5-2). There are three main parts within the framework: Constraint Meta-network Development (CMD), constraint tracking and removal, and dynamic constraint analysis. Each of them is explained in detail as follows.

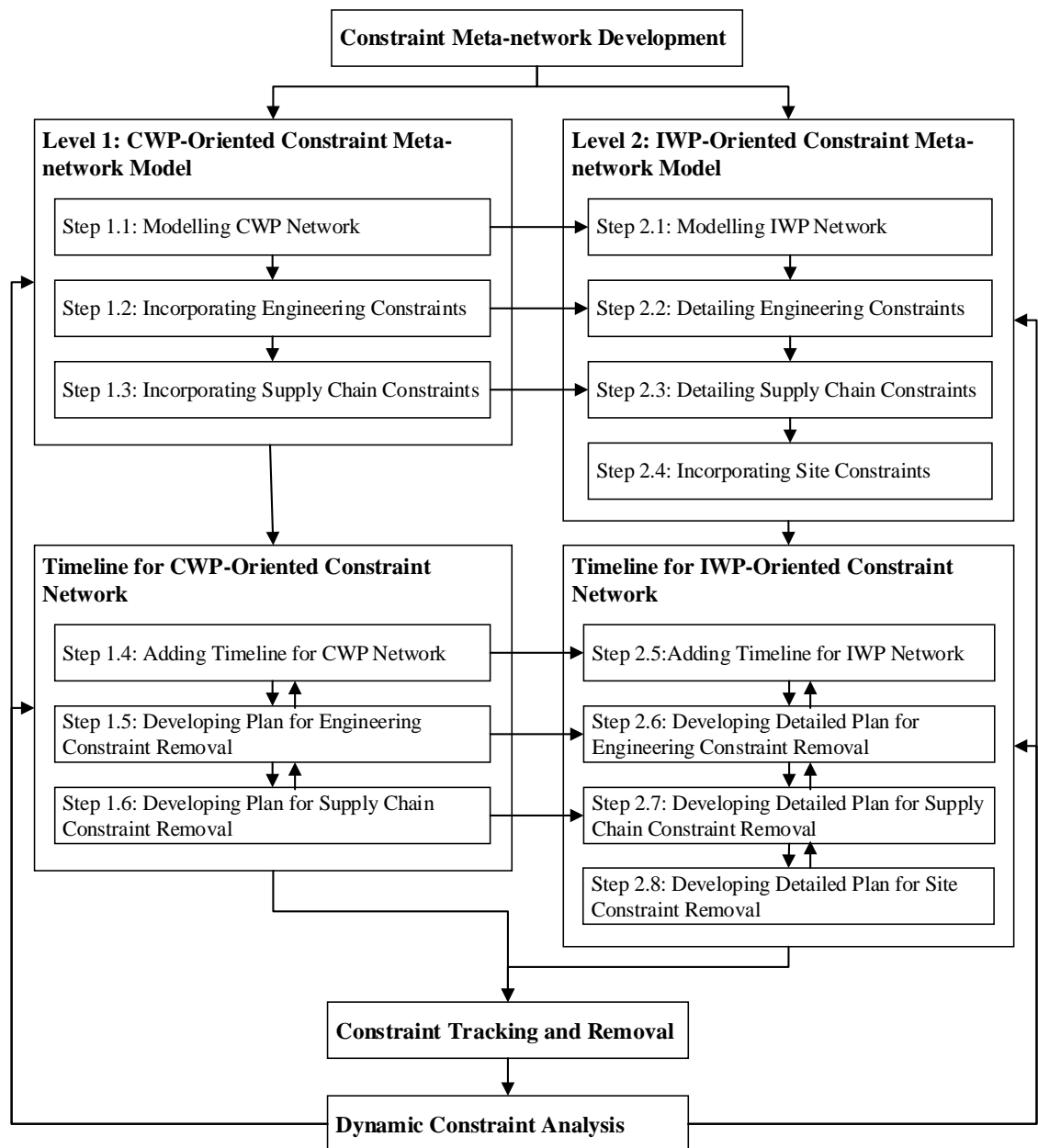

Figure 5-2: Framework of DNA for Constraint Management in LNG Construction

### 5.3.1 Constraint meta-network development

CMD is key to allow project managers and engaged partners to have a thorough understanding of interconnections among constraints. There are two levels of constraint meta-network which need to be developed as project progresses: CWP-oriented Constraint Meta-network Model (CCMM) and IWP-oriented Constraint Meta-network Model (ICMM). The former one is established in the project planning stage, and aims to identify long lead-time constraints and align engineering and procurement plans to construction plan. The latter one is firstly created in detailed design stage and then maintained through the whole construction stage. The purpose of ICMM is to identify detailed constraint information especially site constraints such as materials, equipment, tools, labour, safety, permits, weather and work space.

#### (1) Level 1: CCMM

The development of CCMM includes six steps from step 1.1 to 1.6. The first three steps can be grouped as a toolbox to construct a static network; the last three steps are another cluster which aims to add time dimension to the network. The detailed description of each step is as follows:

##### *Step 1.1: Modelling CWP Network*

A CWP is a grouping or breakdown of work with logical geographical limits (CII 2013). The CWP network can be established in three sub-steps: (1) Determining the boundaries and scopes of CWPs (i.e. nodes); (2) Formulating the sequence (i.e. connections) for the execution of the CWPs; and (3) Assigning superintendent or coordinator (i.e. agents) to each individual CWP. Assumptions for the first sub-step are initial engineering deliverables (e.g. pilot plan of general arrangement drawings, major equipment list, piping line list, and project milestone schedule), work processes and project execution philosophies (CII 2013). In the first sub-step, the process of boundary determination is mainly driven by project physical location, construction methods, and best practices. The size and scope of a CWP depend on the construction plan and contracting and procurement strategies. When CWPs are defined, the next sub-step is to establish connections between the CWP nodes. When deciding the sequence of the CWPs, project planners need to consider geographical layout of systems, client contract milestones, and system turnover sequence. After the first two sub-steps, people in charge of each CWP should be added into the network. Figure 5-3 illustrates an example of the CWP network. The nodes of agents are not shown in this network and the following two examples, because the connections among CWPs, engineering constraints and supply chain constraints, can be clearly demonstrated in this way. However, a complete example of all types of nodes is given in the Validation Section. The sizes of the nodes are decided by their degree within

the network (Degree indicates the connectivity of nodes which provides information on how many other nodes are connected to a particular node).

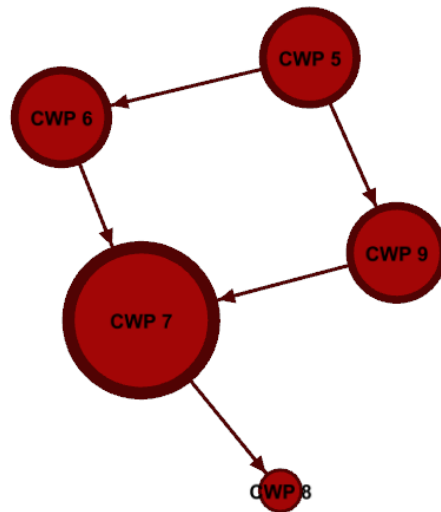

Figure 5-3: An Example of CWP Network

#### *Step 1.2: Incorporating Engineering Constraints*

In the LNG industry, in order to effectively manage engineering constraints, project managers prefer to define engineering into workable packages (i.e. EWP) that can be engineered separately, or that can be scheduled to support engineering workflow (CII 2013). In this thesis, EWPs are used to represent engineering constraints in the constraint meta-network. The boundaries of EWPs need to be consistent with CWPs, and the scope of each EWP should clearly show the final engineering deliverables (i.e. individual engineering constraints such as General Arrangements, 3D models, isometrics and Bill of Materials). It is not necessary to make a one-to-one correspondence between a CWP and an EWP. In general, one CWP can connect with more than one EWPs, however, one EWP should have only one connection with a CWP. Figure 5-4 shows the result after incorporating engineering constraints. The sizes of the nodes are determined by their out-degree (The number of tail ends adjacent to a node is called the out-degree of the node) within the directed network.

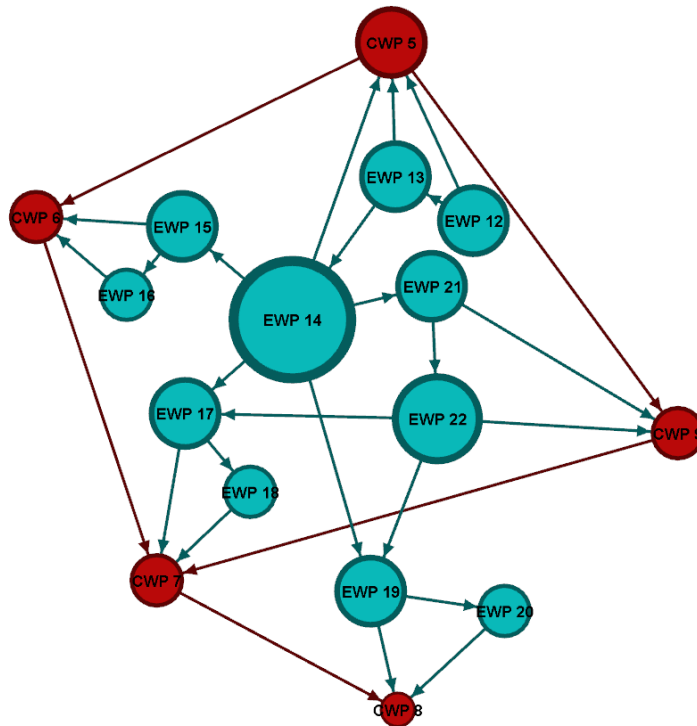

Figure 5-4: Result after Incorporating Engineering Constraints

*Step 1.3: Incorporating Supply Chain Constraints*

Supply chain constraints are also represented by PWPs within the constraint meta-network. There are three types of PWPs which are used for purchasing bulk materials, instruments and offsite fabricated modules, respectively. The last two types of PWPs should be focused upon because of their long-lead time. Lots of uncertainties could happen during the processes of production, delivery, and handling and lifting into the final locations. PWPs can interact with both EWPs and CWPs. Engineers need information from PWPs such as instrument and vendor data to finish their EWPs; Purchasers also require information from EWPs such as Bill of Materials and specifications to develop their PWPs. Knowing the supply chain constraints, especially the unique and/or long-lead material items, can help facilitate the execution of CWPs and EWPs. Figure 5-5 shows the result after incorporating supply chain constraints.

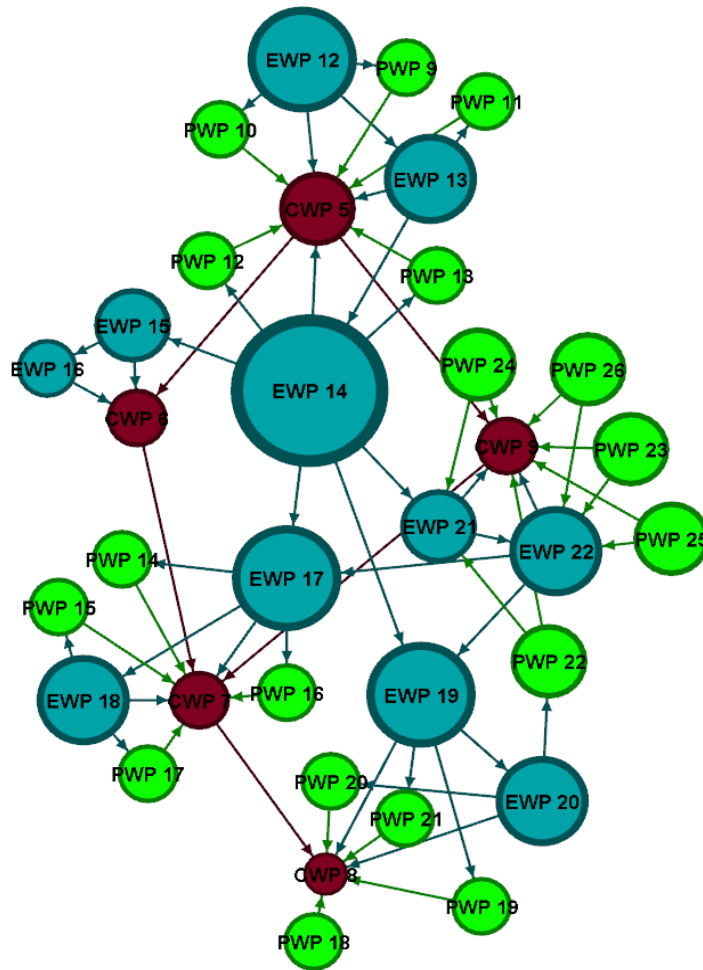

Figure 5-5: Result after Incorporating Supply Chain Constraints

*Step 1.4: Adding Timeline to CWP Network*

Timeline for CWP execution is key to establish alignment with engineering. There are three assumptions for this step. The first one is to identify the major schedule milestones; the second step is to understand project permit requirements; and the last one is to determine the long lead-time items with rough delivery times and rough weights and dimensions. It is better to engage engineers and purchasers to develop the timeline, because the reliability of the construction planning can be limited by the timing of the engineer’s deliverables. In extremely cold climates, weather risks also need to be considered. The timeline should be updated as the project matures.

*Step 1.5: Developing Removal plan for Engineering Constraints*

The objective of this step is to achieve effective project execution through early collaborative planning with construction managers according to the output of Step 1.5. If engineers have already developed their work plan based on the EWPs defined in Step 1.2, the work plan can

be used as a reference to estimate the removal time for each engineering constraints; If not, the engineering plan can be developed on the basis of the CWP execution plan. Ultimately, engineers should timely deliver the EWPs (i.e. remove the engineering constraints) to support construction work plans. The output of this step is a preliminary engineering constraint-removal plan, consistent with the preliminary CWP execution plan. At the end of this step, the engineering team should understand its role in providing EWPs.

*Step 1.6: Developing Removal Plan for Supply Chain Constraints*

The procurement and logistics plan (both offsite and onsite) must support construction and engineering plans. The plan for the offsite fabricated module, with logistics onsite, should be carefully developed. Methods for materials management and inventory need to be determined in this step. The outputs include a feasible removal plan of supply chain constraints, and a process for expediting vendor drawings and vendor surveillance. At the end of this step, the procurement team should have a good understanding of the PWPs including delivery durations and lead-times.

**(2) Level 2: ICMM**

In general, IWPs are developed based on CWPs, and do not across CWP boundaries (CII 2013). The development of ICMM includes eight steps from step 2.1 to 2.8. Compared with CCMM, ICMM has another two extra steps (i.e. 2.4 and 2.8) which are related to site constraints. The remaining six steps (i.e. 2.1 to 2.3 and 2.5 to 2.7) are similar to the development of CCMM. In addition, in the Validation Section (i.e. Section 5.4), a complete ICMM is created for the selected case. Hence, only step 2.4 and 2.8 are described as follows.

*Step 2.4: Incorporating Site Constraints*

In this step, the major dependencies and boundaries that support IWP development are identified. The detailed EWPs for each IWP installation are defined in Step 2.1. The detailed supply chain constraints such as bulk materials are also packaged into PWPs and connect to IWPs in Step 2.3. Additional constraints from tools and equipment, labour, permits, work space and other sources need to be recorded and managed, which is the purpose of this step.

*Step 2.8: Developing Detailed Plan for Site Constraints Removal*

When a rough schedule and sequence of the IWPs is in place, site constraints identified in Step 2.4 should be well planned so as to support the initial IWP execution plan. The outputs of this step include, but not limited to: workforce plans, construction equipment allocation plans, site logistic plans and permit management plans. At the end of this step, the construction team should have an in-depth understanding of the site constraint management.



### **5.3.2 Constraint monitoring and removal**

In a real LNG construction situation, the statuses of constraints change over time. The latest constraint information is important for project managers to assess progress and release constraint-free work packages. When project suffers delay, the up-to-date status of constraints can also be used as references for catching up. There are three processes within constraint monitoring. The first one is constraint tracking which focuses on tracking each individual constraint. The approaches for constraint tracking can be automated, semi-automated or manual which depend on project requirement and technology maturity. For example, material constraints can be automatically tracked by RFID (Navon and Berkovich 2006), while safety constraints may still need to be manually checked by site workers.

The second process is constraint status updating which focuses on calculating the maturity of a task or a work package. The maturity index is intended to support both short-term decision making by team leaders, before they commit to performing tasks, and also to support weekly-planning activities (Sacks et al. 2010). All the tracking data from the first sub-step are collected for the maturity index calculation. Table 5-2 shows an example of maturity index for a piping EWP.

Table 5-2: An Example of Maturity Index for A Piping EWP

<b>Tasks</b>	<b>Maturity</b>	<b>Probability of the Connection</b>
EWP identified and mapped to CWP	5%	95%
Initial scope identified (line numbers)	20%	80%
Preliminary equipment data received	25%	75%
Initial routing of lines established	45%	55%
Initial bulk material to supply chain	55%	45%
Piping studies received for critical lines	60%	40%
Final vendor data received	70%	30%
Final routings completed	75%	25%
Process and Instrumentation Diagrams and Line Designation Table issued for construction	80%	20%
Stress analysis for large bore completed	85%	15%
Bill of Materials completed	90%	10%
EWP complete with all drawings/specs issued for construction	95%	5%
EWP accepted by Construction	100%	0%

The final process is constraint checking, which focuses on comparing as-actual constraint status with an as-planned constraint-removal plan. The frequency of constraint checking is dependent on the project stages and characteristics. For example, the frequency can be monthly or weekly at project early stage, and then updated daily at construction stage. Different action strategies should be performed according to the checking results. If the results indicate several delays of constraint removal, catch up action needs to be conducted.

Constraint removal is mainly executed in the stage of look-ahead planning. Constraints cannot be removed unless either of the following two conditions is satisfied: (1) the probability of the constraint connection is zero; or (2) the probability index can be estimated as zero based on forecasting or reliable commitment.

### 5.3.3 Dynamic constraint analysis

The purpose of dynamic constraint analysis is to help project managers to efficiently detect conflicts within the constraint meta-network from a dynamic perspective, and identify critical constraints in real time before and during project execution. The constraint meta-network developed in Section 4.1 can be analysed by a series of quantitative measures, predominately in two categories: network-level measures and node-level measures. The former describes the entire network or a subnetwork, and the latter describes the features of a single node. Table 5-3 shows the selected five measures and their functions.

The first measure is Number of Unconnected Components at time  $i$  ( $NUC_i$ ) which is used to calculate the number of unconnected components at time  $i$ . Figure 5-6 shows an example to demonstrate the usage of the  $NUC_i$  measure. The filled circles represent IWPs, and the hollow circles are constraints. The date near the cycle is the planned date for constraint removal or IWP execution. When  $i=14/05/2015$ , there are three constraints connected to the IWP, and the value of  $NUC$  is zero; when the time changes to  $19/05/2015$ , the constraint of ID 1 is removed, and the value of  $NUC$  remains the same; When  $i=20/05/2015$ , the IWP has been released to construction site while the two constraints still exist, and the value of  $NUC$  is two. However, according to the Pull concept, the IWP cannot be released unless all the three constraints are mitigated. Hence, we can conclude that if  $NUC$  is not zero, there will be conflicts between construction plan and constraint-removal plan, and the value means the number of the conflicts.

The second measure is Variance of Constraint Removal at time  $i$  ( $VCR_i$ ) that indicates the variance of constraint removal at time  $i$ . For instance, at a given time point, if the value of Actual Number of Constraint Links (ANCL) is greater than the value of Planned Number of Constraint Links (PNCL), that means there are delays in constraint removal. The value of the  $VCR_i$  indicates the number of constraints that are not timely removed.

The third measure is Variance of IWP Released to Site at time  $i$  ( $VIRS_i$ ) that indicates the variance of IWP released to the site at time  $i$ . The value of the  $VIRS_i$  is decided by the difference between the Actual Number of IWP Nodes (ANIN) and Planned Number of IWP Nodes (PNIN). At a given time point  $i$ , if the value of the  $VIRS_i$  is positive, it means that the progress of the field execution is behind schedule, otherwise, before schedule.

The last two measures, i.e. Out-Degree of a Constraint Node (ODCN), and In-Degree of a CWP/IWP Node (IDCN/IDIN), are used to help decision-makers to identify the critical constraints and work packages within a constraint meta-network, respectively. The value of the ODCN is calculated based on the out-degree of a constraint node. While the value of IDCN or IDIN is based on the in-degree of a work package node.

Table 5-3: Five Measures for the Dynamic Constraint Analysis

Measures	Referenced algorithms	Functions
Network-level: Number of Unconnected Components at time i (NUC <sub>i</sub> )	(Tarjan 1972)	Detecting conflicts between construction plans and constraint-removal plans
Network-level: Variance of Constraint Removal at time i (VCR <sub>i</sub> )	$VCR_i = ANCL_i - PNCL_i$ ANCL <sub>i</sub> : Actual Number of Constraint Links at time i; PNCL <sub>i</sub> : Planned Number of Constraint Links at time i.	Evaluating the delay of constraint removal
Network-level: Variance of IWP Released to Site at time i (VIRS <sub>i</sub> )	$VIRS_i = ANIN_i - PNIN_i$ ANIN <sub>i</sub> : Actual Number of IWP Nodes at time i; PNIN <sub>i</sub> : Planned Number of IWP Nodes at time i.	Evaluating field installation progress
Node-level: Out-Degree of a Constraint Node (ODCN)	-	Identifying critical constraints before or during construction execution
Node-level: In-Degree of a CWP/IWP Node (IDCN/IDIN)	-	Identifying critical CWPs/IWPs before or during construction execution

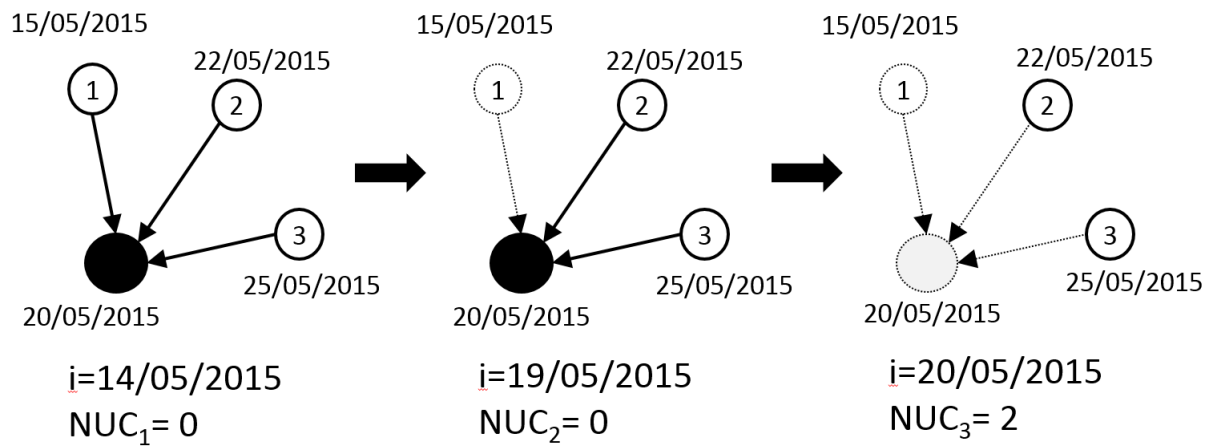

Figure 5-6: An Example of the Use of  $NUC_i$  Measure

### 5.4 Validation

In order to validate the proposed framework of DNA, *Laboratory Experiment 1* explained in Section 3.2.2, Chapter 3, was developed and implemented based on a LNG lean construction simulation game (as shown in Figure 5-7). The objective of the simulation game was to build an LNG train. The construction tasks contained: site preparation, module installation (the modules are manufactured off-site), pipework installation, wiring installation, and major equipment installation.



Figure 5-7: LNG Lean Construction Simulation Game

### **5.1 Experiment Design**

In order to simulate engineering constraints removal, all the drawings and specifications were taken into predefined engineering offices respectively. The releasing time for these drawings and specifications to the construction site was planned by engineering manager. 83 EWPs, 92 PWPs, and 172 IWPs were developed for the simulation game. The project manager was provided with a construction plan, an engineering plan, and a procurement plan. ICMM was created (as shown in Figure 5-8a and Figure 5-8b) before starting the game. There were 1766 nodes and 2589 links (1947 constraint links, 297 sequence links, and 345 superintendent links) within the network. The value of the modularity was 0.855 and twenty communities were identified. The network diameter was thirty-four, and the average path length was about eleven. Detailed constraints for each IWP could also be checked (as shown in Figure 5-9). For example, when clicked “IWP 2.10”, the project manager could find all related constraints and the superintendent. In order to simulate the process of constraint tracking and removal, the project manager was allowed to walk around to get all the latest status of the constraints. The play was finished after 28 minutes.

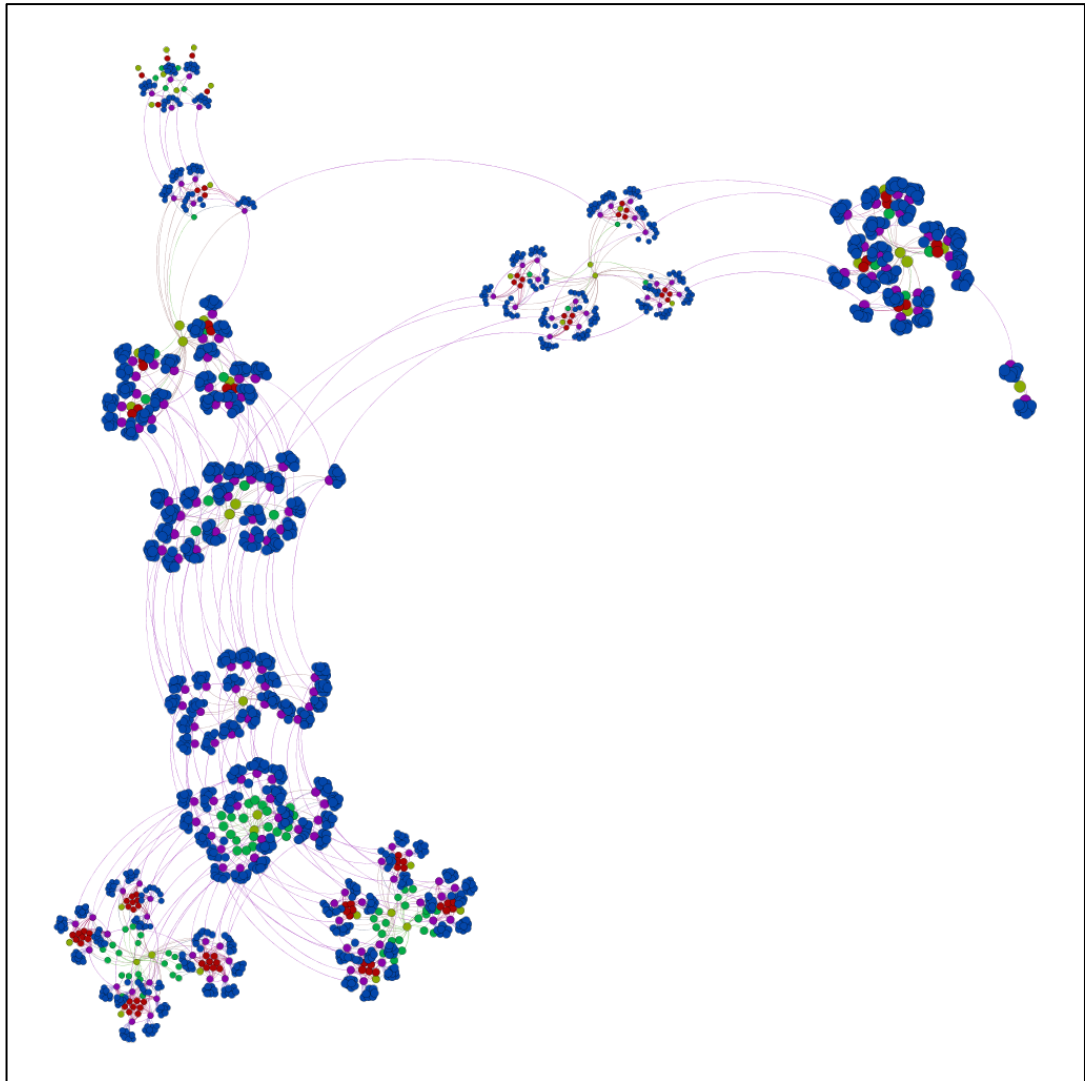

Figure 5-8a: Global View of the ICMM

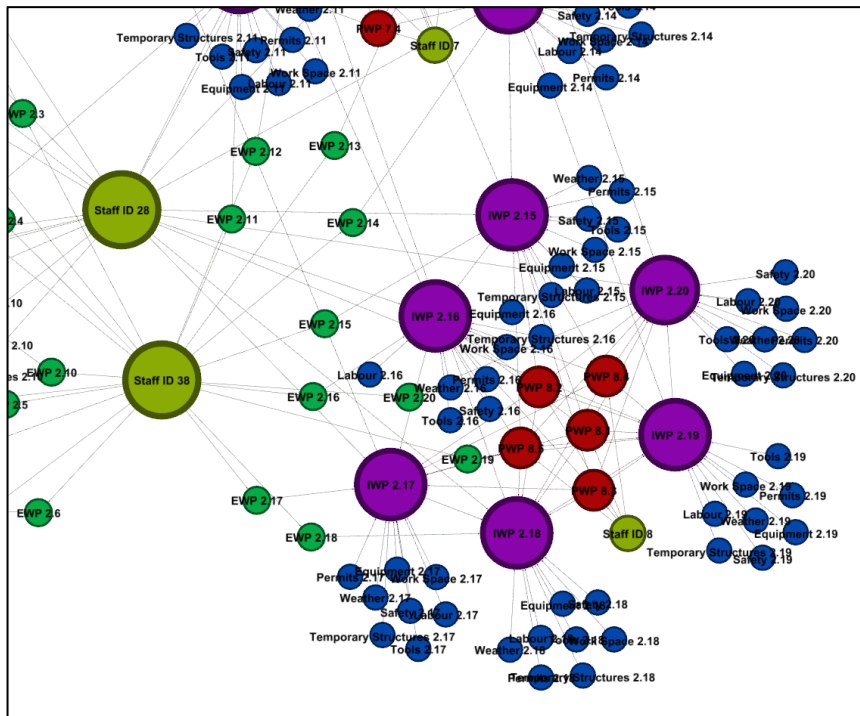

Figure 5-8b: Partial Enlarged View of the ICMM

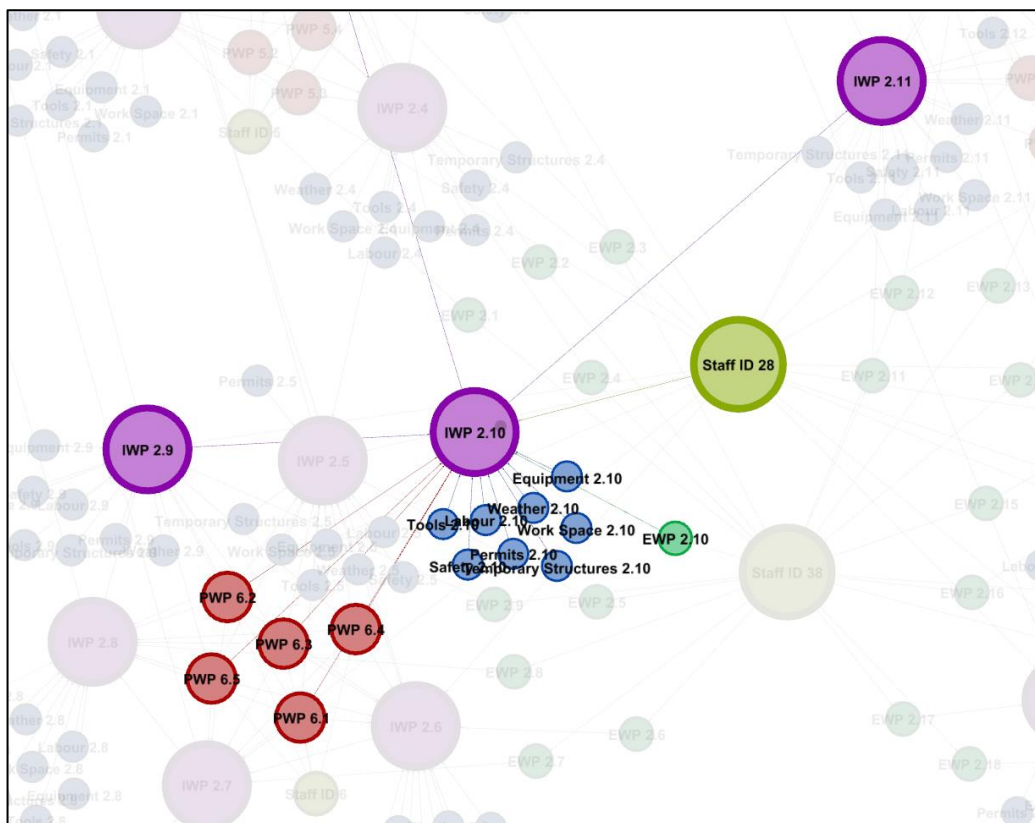

Figure 5-9: Detailed Constraint Check for IWP 2.10



### 5.4.1 Results

Measures developed in Table 5-3 were calculated during the experiment. Figure 5-10 showed the results of conflicts between the given construction plan and constraint-removal plans. Five engineering constraints were planned to be removed behind the releasing time of the related IWPs, and twelve for supply chain constraints and twenty-three for site constraints. The detection process was conducted three times in three different sub-networks defined in Section 3: ECN, SCCN and SCN, respectively.

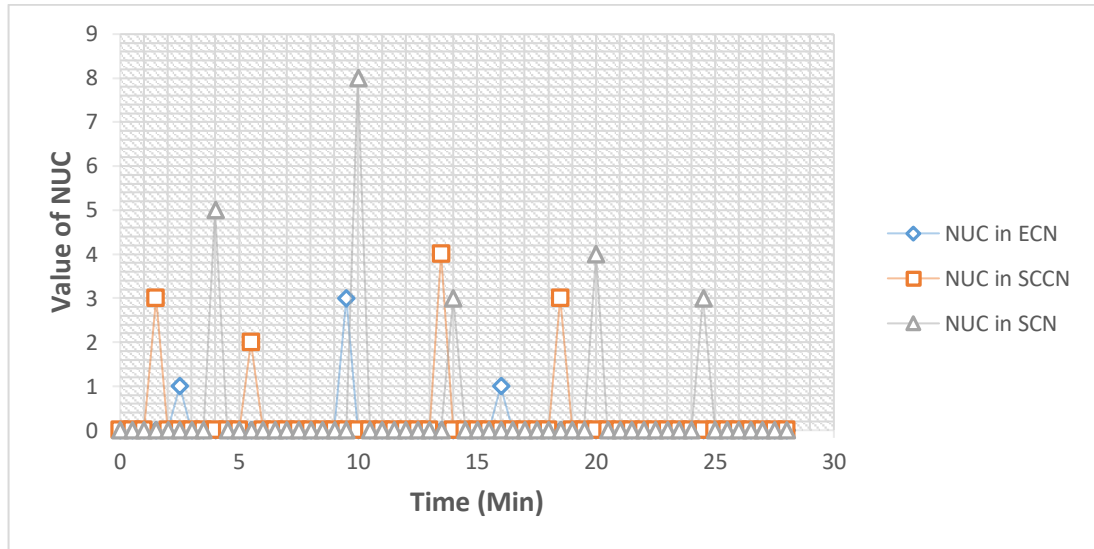

Figure 5-10: Results of Conflicts between the Given Construction Plans and Constraint-Removal plans

Figure 5-11 shows the progress of constraint removal during the experiment. Because of the ideal play environment and the sound project execution plans, the constraints were removed quite smoothly. When comparing the values of  $ANCL_i$  and  $PNCL_i$ , they were almost coincident. Tiny fluctuations occurred after nine minutes playing, and lasted about five minutes. The underlying reason was that one offsite fabricated module did not meet the quality requirement and needed to return back for repairing.

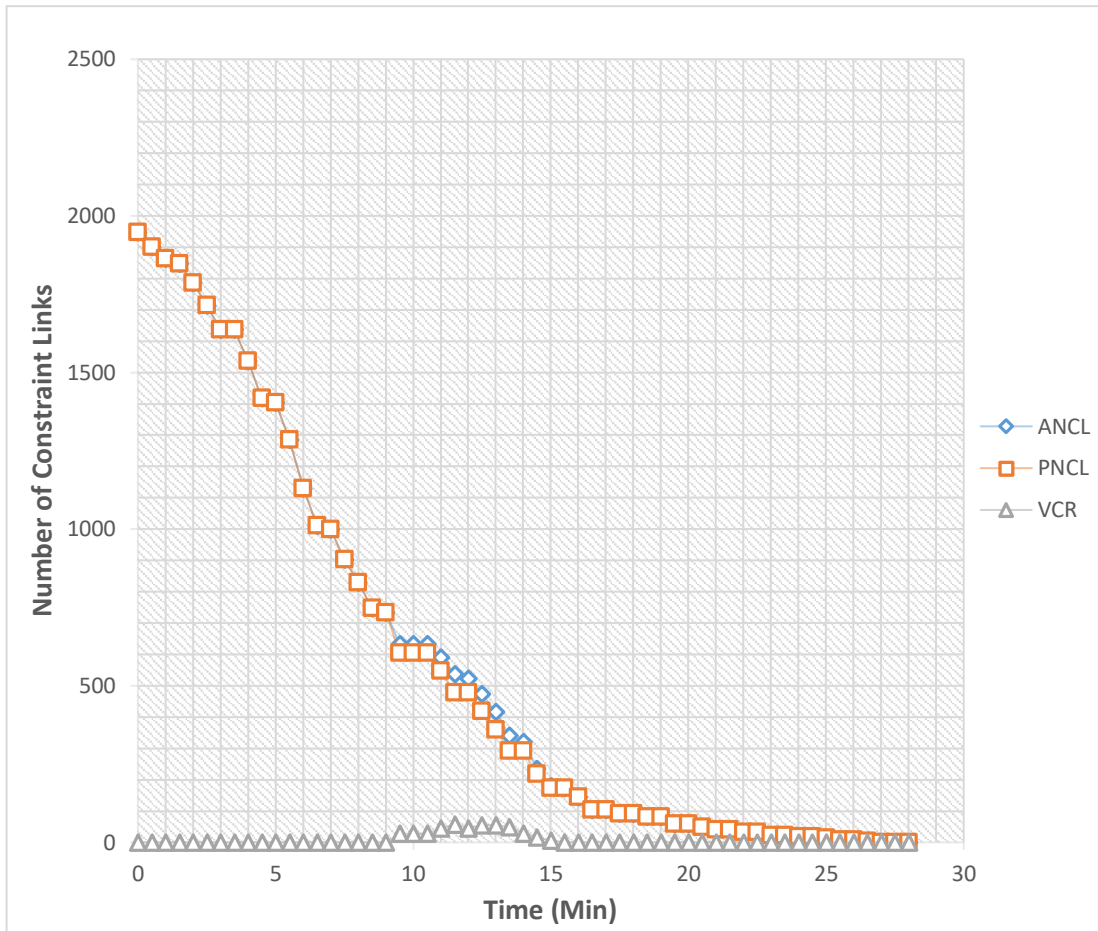

Figure 5-11: Progress of Constraint Removal during the Experiment

Figure 5-12 illustrates the progress of IWP installation. The delay came ten minutes late after the game started. A total of six IWPs were influenced and released later than the planned time. Knock-on impact was the main reason, hence, it was necessary to add more buffer to the hardest and least controllable constraints.

The measures of ODCN and IDIN were only calculated at the beginning of the game. Four engineering constraints were recognised as critical which were related to civil and mechanical design, and their values of ODCN were six; thirty supply chain constraints were detected as critical which were associated with the module fabrication. The maximal value of IDIN was nineteen, and eighteen IWPs were identified as critical, and they were all related to the wooden box assembly.

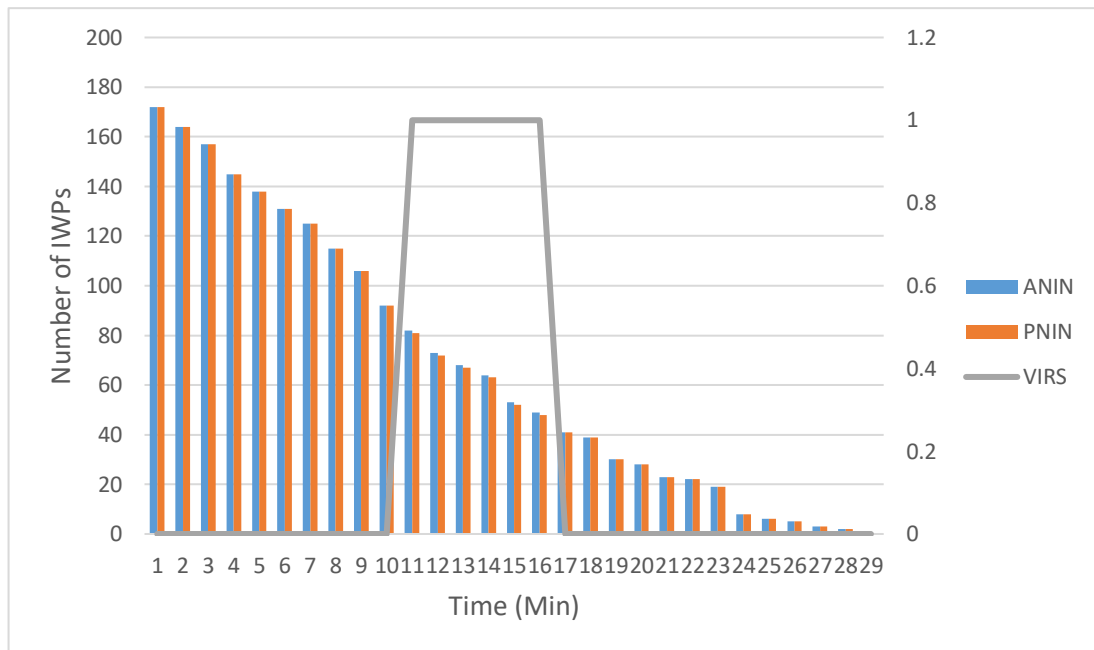

Figure 5-12: Progress of IWP Installation

#### 5.4.2 Limitations

There are a few limitations that should be highlighted. First, the research is limited to an LNG project and is based on the AWP method. This research does not take into account the Last Planner System which may be considered in future research. Second, the measures developed in this research are basic and do not consider the weight and probability of the links. In a real constraint meta-network, the weight of each constraint link should be assigned a different value because their uncertainties are different. In addition, during project execution, the weights of the constraints should be changed as the constraints mature. The last limitation is related to the validation. Field test is needed to bring the proposed framework into the real world to assess its performance.

#### 5.5 Conclusions

Results from the simulation game indicate a positive effect of facilitations when implementing DNA in LNG construction. The intellectual merit of this research is twofold. This is the first use of DNA in LNG construction project and it is the first application of the measures of  $NUC_i$ ,  $VCR_i$ ,  $VIRS_i$ ,  $ODCN_i$  and  $IDIN_i$  in constraint management research. Although this concept was developed and applied in the LNG project, it can have an extended impact on the construction community, such as building and infrastructure. The steps used to develop a meta-network as well as the defined measures, are thoroughly outlined and can be applied to other

projects or aspects related to construction. Project management teams can use the DNA to visualise the interconnected nature of the various constraints and use these links to see how a delay of a specific constraint can influence other constraints or construction works.

## **Chapter 6: Improving Cross-domain Constraint Information Sharing in LNG Construction through Linked Data Technology**

### **6.1 Introduction**

Effectively accessing constraint information is critical to reduce planning uncertainties and improve construction work flow. However, these constraint information is still locked in isolated systems and databases, and uses different, usually not aligned, vocabularies and schemes. For instance, the development of the Shell Floating-LNG project involves teams from more than seven countries including Australia, South Korea, Dubai, Malaysia, Singapore, France and Spain. Currently, there is not an efficient way to access all these constraint information. Take the engineering constraint as an example, for a typical LNG project, there are at least three main design groups who are in charge of offshore platform, onshore plant, and subsea infrastructure, respectively. In each design group, there are a number of specialty engineering companies such as civil infrastructure, mechanical system, piping system, electrical system, and security service. They all prefer to use their own platforms or applications to perform their engineering works. Therefore, it is impossible to build an integrated platform for project participants to get access to these information.

Chapter 6 develops a semantic approach for cross-domain constraint information sharing by using linked data technology (i.e. *Research Objective 3*). Compared with conventional approaches for data integration, linked data principles enable data to be delivered in both machine- and human-readable formats. Making constraint data on the Web enables greater transparency and accountability, and helps project participants to access required information more efficiently. All project participants can access the various constraint data through a Simple Protocol and Resource Description Framework Query Language (SPARQL) endpoint.

### **6.2 A Linked Data-enabled Approach for Cross-domain Constraint Information Sharing**

In order to address the four issues discussed in Section 2, a linked data-enabled approach for cross-domain constraint information sharing is proposed (as shown in Figure 6-1) which includes four layers: (1) Data wrapper and publication; (2) Linked constraint cloud data; (3) Data access and inference; and (4) Applications.

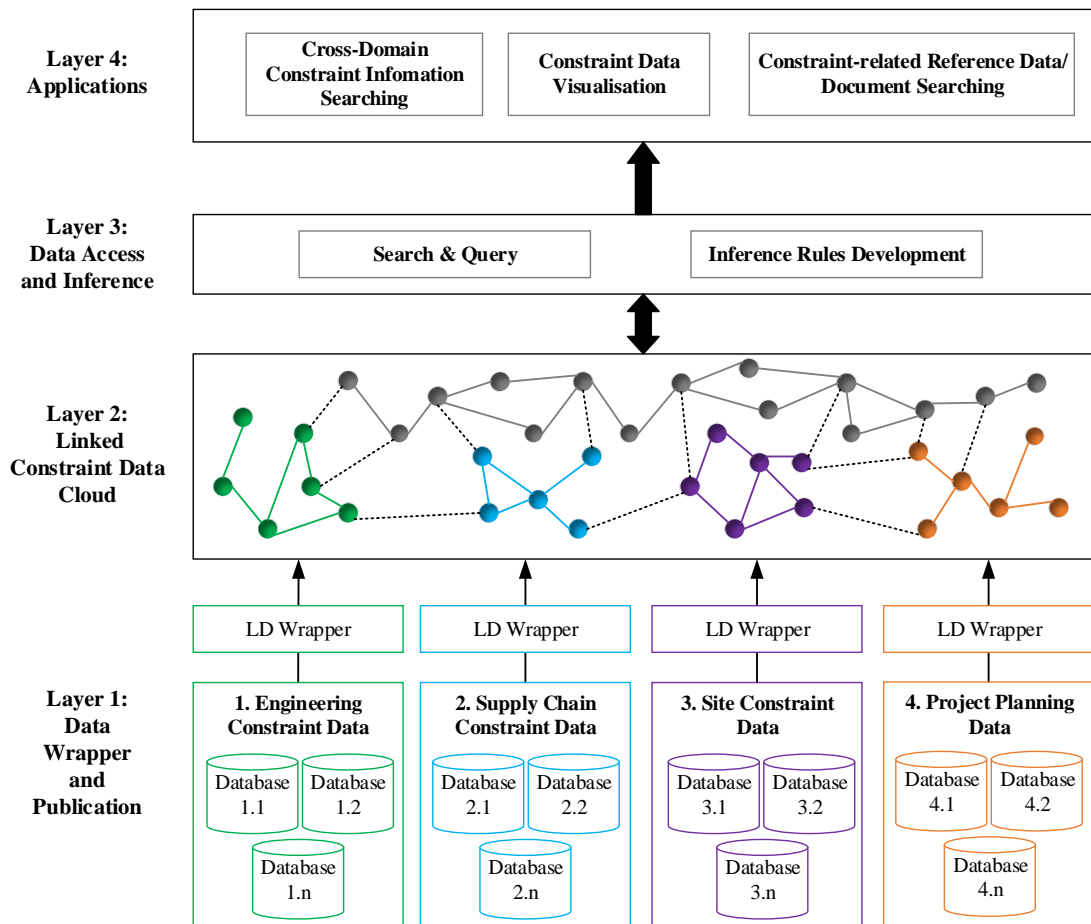

Figure 6-1: A Linked Data-enabled Approach for Cross-domain Constraint Information Sharing

In the first layer, the linked data wrappers perform the “RDFisation” process, which transforms existing legacy data into linked data according to the relevant vocabularies or ontologies. Four types of constraint data need to be converted to RDF format which include: Engineering constraint data, Supply chain constraint data, Site constraint data, and Project planning data. The process of data wrapper and publication consists of two main steps, namely, vocabulary & ontology selection and development, and RDF data transformation. The purpose of the first step is to provide domain-specific terms for describing resources in the world and how they relate to each other. The second step is to utilise the developed terms to convert existing multiple data formats into RDF. Detailed explanations of the vocabularies & ontologies selection and development, and RDF data transformation is presented in Sections 5 and 6 respectively.

In the second layer, the separate RDF graphs of data developed from the first layer are interconnected together to create a global data cloud. The interconnection network is created by adding external RDF links between data entities across isolated data graphs. In Figure 6-1,

the links within a domain data set are represented by the solid lines, and the external links among multiple data sets are represented by the dashed lines. With these links, a global, interconnected data space for cross-domain constraint information sharing and management can be generated. The details of the data interconnection process are discussed in Section 7.

In the third layer, the linked constraint data cloud can be searched and queried through linked data search engines. The basic approach to access the data cloud is to dereference HTTP URIs into RDF descriptions and to discover additional data sources by traversing RDF links. In addition, parts of the graph may also be accessed via SPARQL endpoints or downloaded in the form of RDF data set dumps. Because of the caching function of the linked data search engines, instead of directly accessing the original linked constraint data cloud, applications can also access the data via the Application Programming Interfaces (APIs) provided by these search engines. The inference rules in this layer concentrate on defining a general mechanism on discovering and generating new relationships based on existing data cloud. Inference based techniques can also detect potential inconsistencies within the linked constraint data cloud. Section 8 presents more details about these two modules.

In the fourth layer, applications that consume the resulting data and events from the linked constraint data cloud are developed. The application of cross-domain constraint information searching can help users who are not familiar with SPARQL language to conduct efficient data query. The application of constraint relationships visualisation is developed to help constraint managers get a global view of the whole constraints, and identify the critical constraint(s) which have a significant impact on construction work flow. The application of constraint tracking and status visualisation is useful for contractors to get the real-time constraint status and adjust their weekly or daily schedules if some constraints are not timely removed as planned. The three applications are demonstrated in details in Section 6.6.3.

### **6.3 Vocabulary & Ontology Selection and Development**

Reuse of existing terms is highly desirable as it maximises the probability that data can be consumed by applications that may be tuned to well-known vocabularies, without requiring further pre-processing of the data or modification of the application (Fensel et al. 2001). Table 6-1 shows the reused vocabularies or ontologies and their descriptions.

Table 6-1: The Reused Vocabularies or Ontologies and Their Descriptions

No.	Reused Vocabularies or Ontologies	Descriptions
1	Simple Knowledge Organization System (SKOS)	Used to express conceptual hierarchies (i.e. taxonomies)
2	RDFS and OWL	Used to describe conceptual models in terms of classes and their properties.
3	Friend-of-a-Friend (FOAF)	Used to describe persons, their activities, and their relationships
4	Dublin Core Metadata Initiative (DCMI) Metadata Terms	Used to general metadata attributes such as <i>title</i> , <i>creator</i> , <i>date</i> , and <i>subject</i> .
5	Basic Geo (WGS84)	Used to describe geographically-located things
6	ISO 15926	Used to describe LNG plant product such as pipeline, instrumentation, and equipment.

ISO 15926 is designed for data integration, sharing, and exchange between computer systems for life-cycle information in process plants, including LNG production facilities. ISO 15926 is organised into a number of parts which can be classified into two categories (Kim et al. 2011): (1) data model and reference data including Parts 2-4; and (2) implementation methods including Part 7-10.

In the first category, Part 2 defines a generic 4D model that can support all disciplines, supply-chain company types, and lifecycle stages regarding information about functional requirements, physical solutions, types of objects and individual objects, as well as activities. Part 3 defines information resources for the representation of geometry and topology in OWL. Part 4 specifies an initial set of common reference data items that can be used to record information about process plants.

In the second category, the Part 7 (ISO 2011a) provides information resources for defining templates and specifies a verification method using First-Order Logic. The Part 8 (ISO 2011b) defines information requirements for the representation of ISO 15926-based plant data in OWL. The Part 9 will specify the implementation method for a triple data repository called façade, which stores ISO 15926-based plant data. The Part 10 will specify an abstract test method.



The ISO15926 ontology consists of several interrelated and distributed modules which can be classified into four main partitions and two auxiliary partitions (as shown in Figure 6-2) (ISO15926 2015). The main partitions include (1) the ISO 15926 upper ontologies (meta models); (2) the Reference Data Library (RDL) and extensions of the RDL; (3) the “workhorses” of lifecycle information and local reference data; and (4) a selection of the lifecycle information, mapped to OWL, for reasoning purpose. The two auxiliary partitions are (1) Template Specifications in eXtensive Makeup Language (XML) format; and (2) Part 7 Proto Templates in First-Order Logic format.

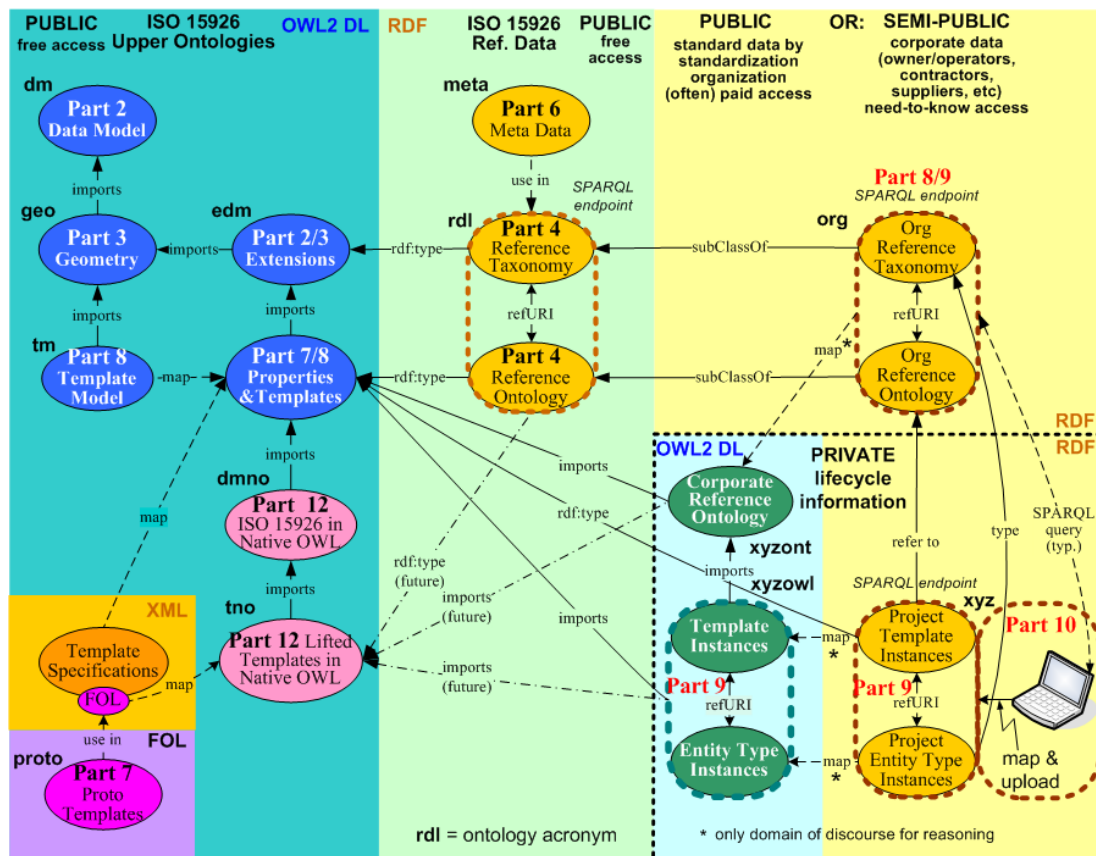

Figure 6-2: Architecture of the ISO 15926 Ontology (ISO15926 2015)

In order to support the data wrappers of the constraint and project planning data, two new domain-specific terms were developed, namely, Constraint ontology and AWP ontology. Protégé (an open-source platform) (Musen 2015) was utilised to construct these two domain ontologies. The ontology development method deployed in this study is derived from the method developed by Noy and McGuinness (2001), and includes the following steps:

- 1) Determine the domain and scope of the ontology. Consider the constraint ontology, the representation of constraints is the domain of the ontology. This ontology is planned to be used for constraint management during LNG construction. The users

and operators of the constraint ontology can be project managers, contractors or owners.

- 2) Enumerate important terms in the ontology. In this step, a list of all terms involved in the domain area needs to be written down. For instance, important terms of constraint ontology include different types of *constraints*, such as *engineering constraint*, *supply chain constraint*, and *site constraint*; subtypes of *site constraint* include *labour*, *equipment*, *safety*, *permit*, *temporary structure*, *tool*, *work space* and so on. The development of this list was supported by answering the following questions: What are the terms that are frequently used? What properties do those terms have? What glossaries are used for defining the terms?
- 3) Define the classes and the class hierarchy. A bottom-up development process was deployed to build up the class hierarchy. The process started with the definition of the most specific classes, the leaves of the hierarchy, with subsequent grouping of these classes into more general concepts.
- 4) Define the properties of the classes. This step aims to describe the internal structure of concepts. For instance, *planned-removal time* and *actual-removal time* are two properties should be attached to the *constraint* class.
- 5) Define the facets of the properties. Properties can have different facets describing the value type, allowed values, the number of the values (cardinality), and other features of the values the property can take. For instance, the value of a *plannedRemovalDate* property (as in “the planned-removal time of a constraint”) is one date. That is, *plannedRemovalDate* is a property with value type *Date*. A property *inChargeOf* (as in “a person is in charge of these constraints”) can have multiple values and the values are instances of the class *Constraint*. That is, *inChargeOf* is a property with value type *Instance* with *Constraint* as allowed class. A value-type facet describes what types of values can fill in the property. The common value types include String, Number, Boolean, Enumerated and Instance. Properties with value type Instance must define a list of allowed classes from which the instances are originated. The allowed classes are called a range of a property. In the above example, the class *Constraint* is the range of the *inChargeOf* property.

Figure 6-3 illustrates the proposed constraint ontology for LNG plant construction. The classes involved in this ontology were built on the constraint classification developed by Wang et al. (2016). The head class of this ontology is *Constraint* which contains three sub-classes: *EngineeringConstraint*, *SupplyChainConstraint* and *SiteConstraint*. The properties of the *Constraint* class can be classified into two categories. The first category describes the basic information of the class such as *hasName*, *hasStatus*, *hasPriority*, and *hasMaturity*. The

second category represents the date-related information such as *createdDate*, *plannedRemovalDate*, and *actualRemovalDate*.

Figure 6-4 shows the proposed ontology for AWP method. The classes involved in this ontology were built on the concepts of AWP developed by CII (2013) and WFP (PMP 2009) developed by Construction Owners Association of Alberta. WFP is the process of organizing and delivering all elements necessary before work is started, to enable craft persons to perform quality work in a safe, effective and efficient manner (Slootman 2007). Within WFP, three different levels of work packages are defined and used to describe different levels of project plans: Construction Work Area (CWA), Construction Work Package (CWP) and Field Installation Work Package (FIWP) (PMP 2009). AWP is a more complete work packaging system than WFP. It covers both the construction and the initial early stages of the project and allows a system more control over the breakdown of the project through its lifecycle (Hamdi 2013). The three key deliverables of AWP are CWP, Engineering Work Package (EWP) and Installation Work Package (IWP).

The root concept of the AWP ontology is the *WorkPackage* which contains five different sub-classes, namely, *EngineeringWorkPackage*, *ProcurementWorkPackage*, *ConstructionWorkArea*, *ConstructionWorkPackage*, and *InstallationWorkPackage*. Each sub-class is broken into sub-sub-classes so that the ontology can best reflect project execution planning and control system. The properties of the *WorkPackage* class includes name (i.e. *hasName*), schedule information such as *startDate* and *finishDate*, man-hour data (i.e. *hasManhour*) and so on.

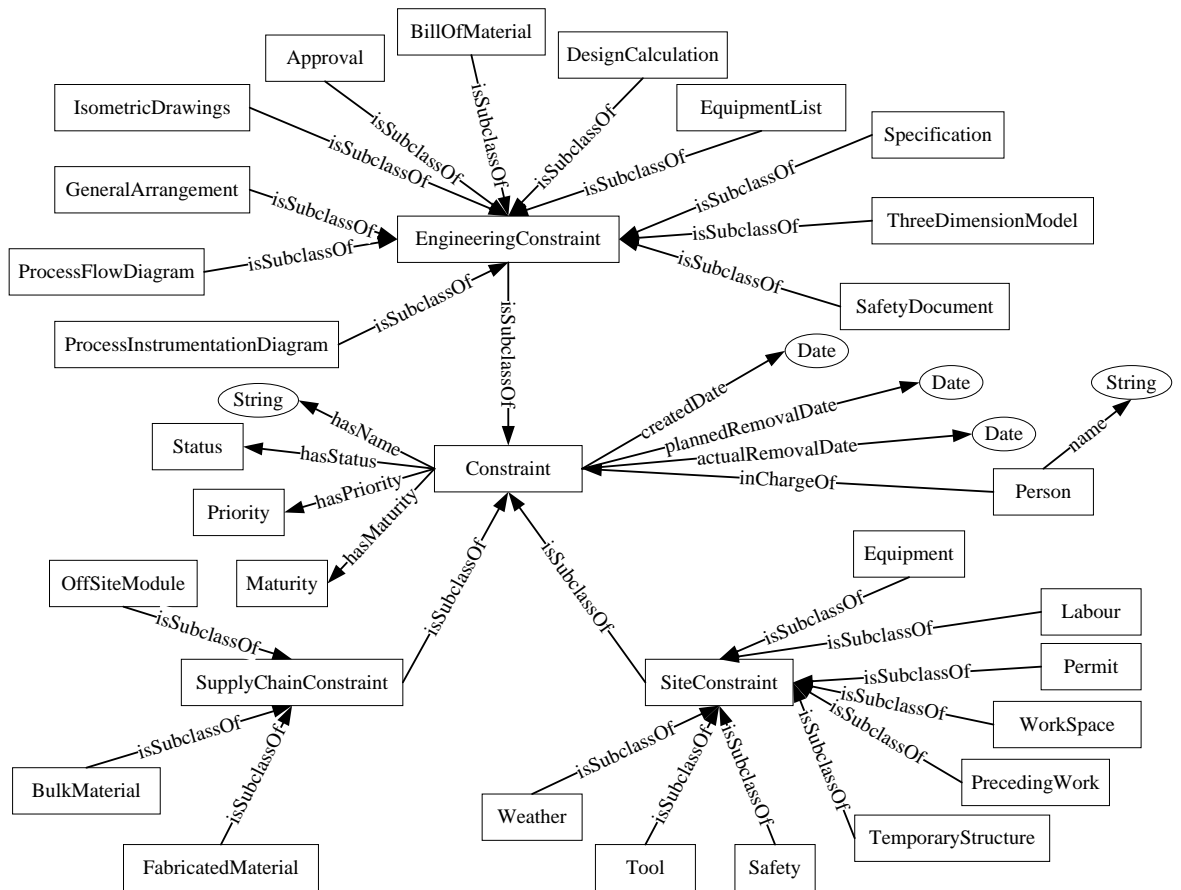

Figure 6-3: A Snippet of the Constraint Ontology

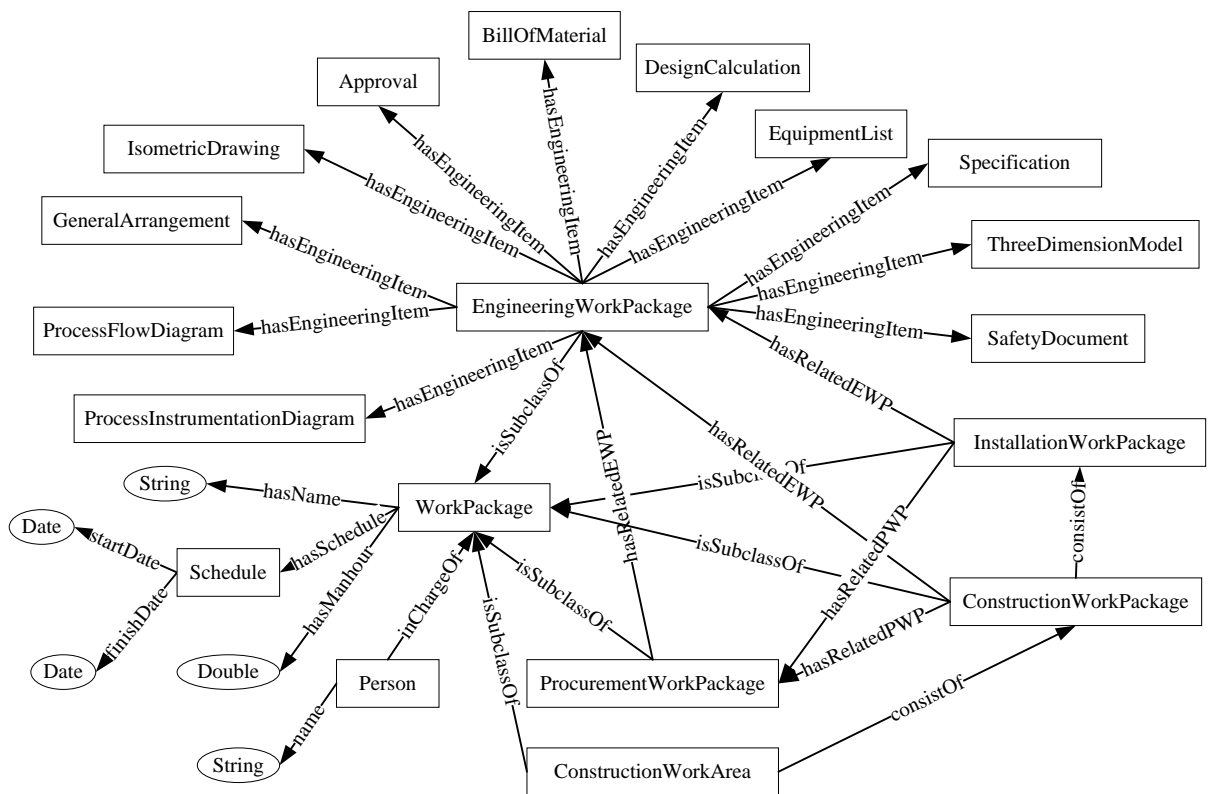

Figure 6-4: A Snippet of the AWP ontology

Domain ontologies (i.e. ISO 15926 ontology, Constraint ontology, and AWP ontology) provide only data architectures and semantic formalisations for diverse data sources. The purpose of the merged ontology (as shown in Figure 6-5) is to interlink these isolated data islands into a unified data space so that the cross-domain constraint information can be shared. In this thesis, the three main developed ontologies were merged by matching synonymous concepts using the *equivalentClass* property. The mapping process could be semi-automated by performing ontology merging and alignment algorithms (Noy and Musen 2000). However, the efficiency and accuracy of the current mapping approaches are not high enough (Noy and Musen 2000). In order to assure the accuracy of the mappings, this study utilised a manual method to define semantic equivalence among entities from the proposed ontologies. The *Constraint* concepts in the constraint ontologies are linked to the *Constraint* in the AWP ontology through the *equivalentClass* property. In addition, sub-classes of *SupplyChainConstraint* (i.e. *FabricatedMaterial*) and *EngineeringConstraint* (i.e. *IsometricDrawing*) in the constraint ontology also have corresponding equivalent classes in the AWP ontology. The *WorkPackage* concept is the bridge between ISO 15926 ontology and AWP ontology. The equivalent classes include *EngineeringWorkPackage*, *ProcurementWorkPackage*, *ConstructionWorkPackage*, and *InstallationWorkPackage*. Based on this merged ontology, any *WorkPackage* instances generated by engineers and *Constraint* instances generated by project planners can be legally linked to data graphs in the downstream phases.

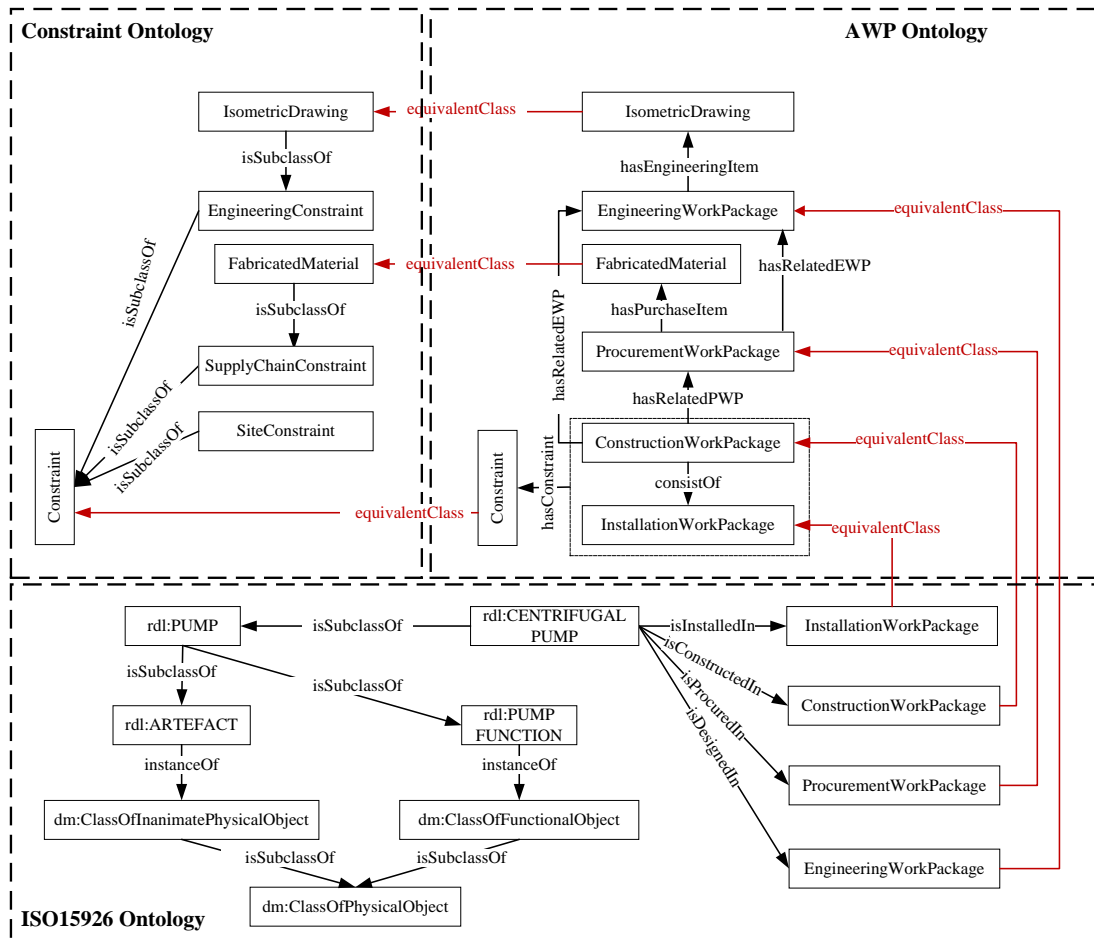

Figure 6-5: The Merged Ontology

## 6.4 RDF Data Transformation

In order to support the interlinkage of data from isolated sources, these data are required to be converted into the RDF format. There are two components in a data wrapper, namely, domain ontology and mapping rules. During the data transformation process, the domain ontology is used as the source of vocabularies, and mapping rules are utilised to assure the converted RDF data model is expressed in a structured and targeted vocabulary. In this study, three types of data wrappers were developed to translate the existing legacy data (i.e. engineering constraint data, supply chain constraint data, site constraint data, and project planning data) to the RDF format: (1) Drawing data to RDF; (2) Table data to RDF; and (3) Document meta-data to RDF. Each of them is described in detail in the following sections.

### 6.4.1 Drawing data to RDF

This type of data wrapper is used to convert engineering constraint data, such as Process and Instrumentation Diagram (P&ID), Isometric, and Process Flow Diagram (PFD) into RDF format. There are two main steps during the data transformation: (1) Plant items identification; and (2) RDF data generation. Figure 6-6 shows a sample P&ID drawing and it will be used as an example to demonstrate the converting process. Firstly, all of the items on the drawing were extracted which include equipment (e.g. Water Injection Pump, Inlet Gas Exchange, and Inlet Separator), and piping systems (e.g. Pipeline 100-SG-120-6SO). Then, the ISO 15926 ontology was used to describe these plant items and their relationships. Figure 6-7(a) illustrates the converted RDF data model in RDF/XML format. In order to help users to visually check the accuracy of the conversion process, the converted RDF data can be further visualised into a graph format (as shown in Figure 6-7(b)).

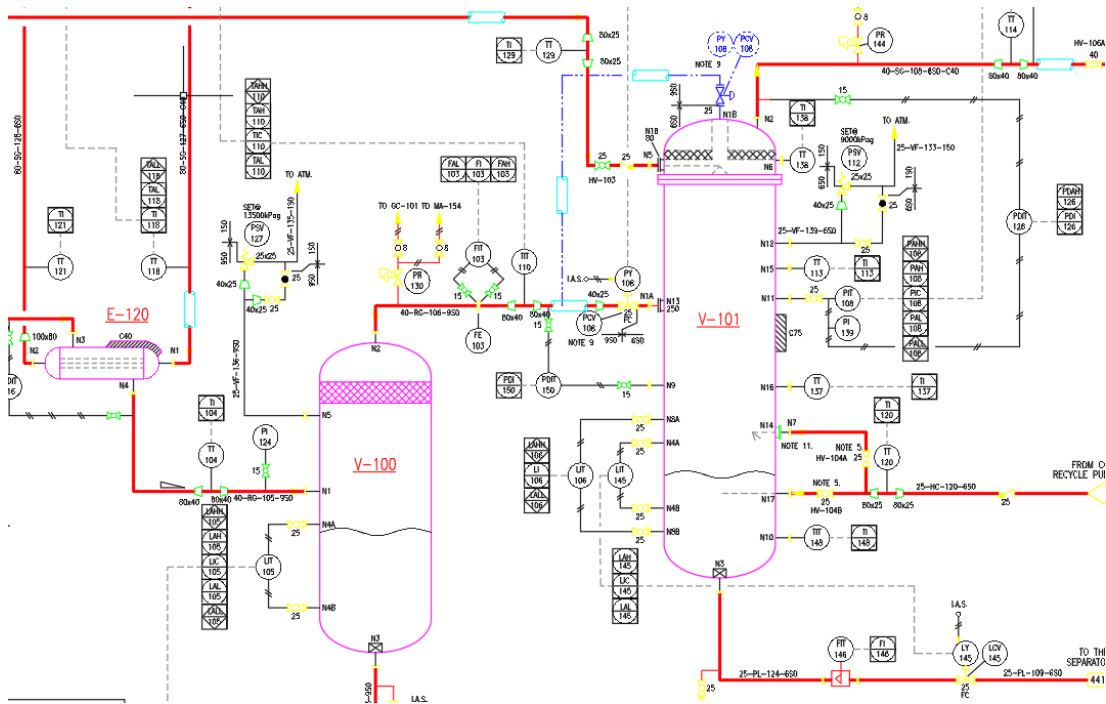

Figure 6-6: A Snippet of the Sample P&ID Drawing

```

<rdf:Description rdf:about="&qn3;id=P-ECHO-BV-103">
<pcardl:hasCreationDate>02/27/17 00:00:00
</pcardl:hasCreationDate>
<pcardl:hasCreator>JunWang</pcardl:hasCreator>
<rdfs:comment>BUTTERFLY VALVE</rdfs:comment>
<rdfs:label>BV-103</rdfs:label>
<qn1:hasLocalId>P-ECHO-BV-103</qn1:hasLocalId>
</rdf:Description>
<rdf:Description rdf:about="&qn3;id=P-ECHO-BV-104">
<pcardl:hasCreationDate>02/28/17 00:00:00
</pcardl:hasCreationDate>
<pcardl:hasCreator>JunWang</pcardl:hasCreator>
<rdfs:comment>BUTTERFLY VALVE</rdfs:comment>
<rdfs:label>BV-104</rdfs:label>
<qn1:hasLocalId>P-ECHO-BV-104</qn1:hasLocalId>
</rdf:Description>
<rdf:Description rdf:about="&qn3;id=P-ECHO-BV-105">
<pcardl:hasCreationDate>03/01/17 00:00:00
</pcardl:hasCreationDate>
<pcardl:hasCreator>JunWang</pcardl:hasCreator>
<rdfs:comment>BUTTERFLY VALVE</rdfs:comment>
<rdfs:label>BV-105</rdfs:label>
<qn1:hasLocalId>P-ECHO-BV-105</qn1:hasLocalId>
</rdf:Description>

```

Figure 6-7(a): A Snippet of the Converted RDF Data Model in RDF/XML Format

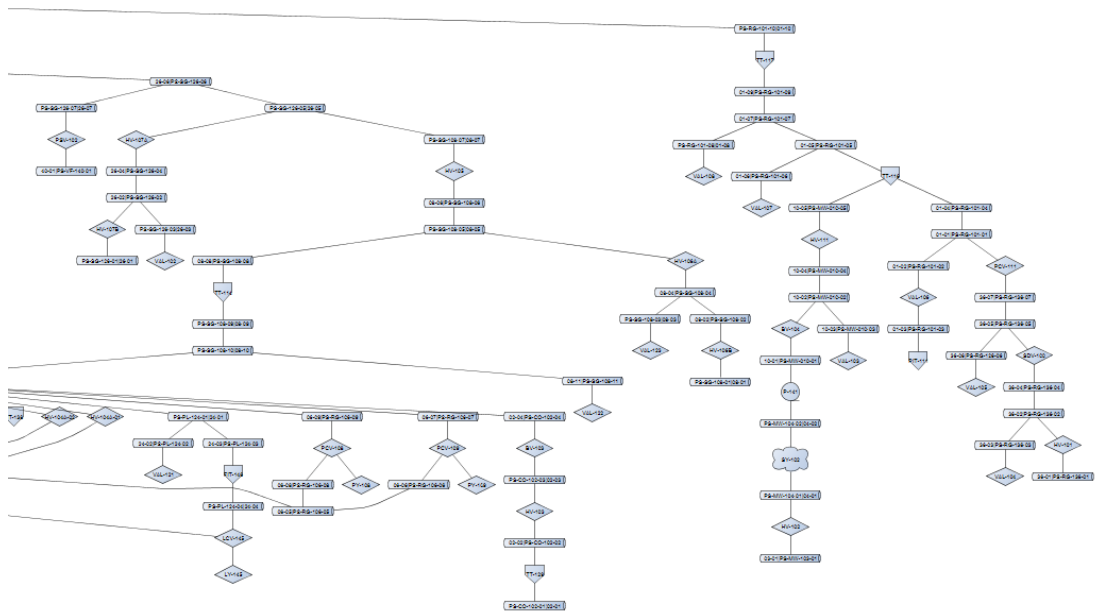

Figure 6-7(b): A Snippet of the Converted RDF Data Model in a Graph Format



### 6.4.2 Table data to RDF

This type of data wrapper is designed for the transformation of table data to the proposed ontologies compliant RDF. In this study, a pattern-based mapping method was utilised to perform the conversion. A pattern is a formally defined as a list of alternative ways (representations) to express particular ontological relation between two or more entities. Each pattern contains three predefined keys with values: (1) key '*name*' with string value; (2) key '*signature*' with dictionary value; and (3) key '*options*' with list value. Pattern *name* is the name of the pattern. Pattern *signature* is a dictionary containing pattern role names and textual description of inverse relations corresponding to roles, for use in output forms. Each item in pattern's *options* list contains definition of one specific way the pattern is realised.

A simple example is given to demonstrate the process. Table 6-2 shows the work package information from the source of the project planning data. Table 6-3 shows the supply chain constraint information from the source of the supply chain constraint data. The many-to-many relationship is captured by the content of Table 6-4. Three patterns were developed (as shown in Figure 6-8) to convert the three tables into RDF, respectively. They are *WorkPackage\_EXAMPLE\_R2RML*, *SupplyChainConstraint\_EXAMPLE\_R2RML*, and *WorkPackage\_2\_SupplyChainConstraint\_EXAMPLE\_R2RML*. Figure 6-9 is the screenshot of the converted RDF data model.

Table 6-2: Work Package Information

<b>WPNo</b>	<b>WPManager</b>	<b>WPType</b>
CWP10001-Equipment	Jun_Wang	Construction_work_package
CWP10002-Equipment	Wenchi_Shou	Construction_work_package
IWP20001-Piping	Peng_Wu	Installation_work_package

Table 6-3: Supply Chain Constraint Information

<b>SupplyChainConstraint</b>	<b>TrackedBySensor</b>	<b>SensorTagNo</b>
Pump101	RFID	0E05070211000729
Vassel100	RFID	0E05070211000895
Spool101	RFID	0E05070211000326

Table 6-4: Relationship between Work Packages and Supply Chain Constraints

WPNo	SupplyChainConstraint
CWP10001-Equipment	Pump101
CWP10002-Equipment	Vassel100
IWP20001-Piping	Spool101

```

patterns.append({'name': 'WorkPackage_EXAMPLE_R2RML',
'signature': {'workpackage' : '', 'manager' : 'has manager',
'number' : 'has number', 'category' : 'works as'},
'options': [{'workpackage' : 'self',
'type': 'http://example.com/ns#WorkPackage',
'manager' : 'hasManager',
'number' : 'hasWorkPackageNumber',
'category' : 'hasCategory'
}]]})

patterns.append({'name': 'SupplyChainConstraint_EXAMPLE_R2RML',
'signature': {'supply_chain_constraint' : '', 'tracked_by_sensor'
: 'has sensor', 'sensor_tag_number' : 'has number', 'item' : 'has
item'},
'options': [{'supply_chain_constraint' : 'self',
'type':
'http://example.com/ns#SupplyChainConstraint',
'tracked_by_sensor' : 'hasSensor',
'sensor_tag_number' : 'hasSensorNumber',
'item' : 'hasSupplyChainConstraintItem'}]})

patterns.append({'name': 'WorkPackage_2
_SupplyChainConstraint_EXAMPLE_R2RML',
'signature': {'workpackage' : 'hasSupplyChainConstraint',
'supply_chain_constraint' : 'includes'},

```

Figure 6-8: Patterns for Mapping and Transformation

```

<?xml version="1.0"?>

<!DOCTYPE rdf:RDF [
  <!ENTITY owl "http://www.w3.org/2002/07/owl#" >
  <!ENTITY awp "http://www.owl-ontologies.com/AWP.owl#" >
  <!ENTITY cons "http://www.owl-ontologies.com/Constraint.owl#" >
  <!ENTITY qn1 "http://data.example.com/awp/" >
  <!ENTITY qn2 "http://data.example.com/constraint/" >
  <!ENTITY rdfs "http://www.w3.org/2000/01/rdf-schema#" >
  <!ENTITY rdf "http://www.w3.org/1999/02/22-rdf-syntax-ns#" >
  <!ENTITY basens "http://example.com/ns#" >
  <!ENTITY xsd "http://www.w3.org/2001/XMLSchema#" >
]>

<rdf:RDF
  xmlns="http://example.com/ns#"
  xml:base="http://example.com/ns"
  xmlns:owl="http://www.w3.org/2002/07/owl#"
  xmlns:awp="http://www.owl-ontologies.com/AWP.owl#"
  xmlns:cons="http://www.owl-ontologies.com/Constraint.owl#"
  xmlns:qn1="http://data.example.com/awp/"
  xmlns:qn2="http://data.example.com/constraint/"
  xmlns:rdfs="http://www.w3.org/2000/01/rdf-schema#"
  xmlns:rdf="http://www.w3.org/1999/02/22-rdf-syntax-ns#"
  xmlns:basens="http://example.com/ns#"
  xmlns:xsd="http://www.w3.org/2001/XMLSchema#"
>
  <awp:WorkPackage rdf:about="#WorkPackage">
  <rdfs:label>WORK_PACKAGE</rdfs:label>
  </awp:WorkPackage>

  <WorkPackage rdf:about="&qn1;CWP10001-Equipment">
  <awp:hasManager>Jun_Wang</awp:hasManager>
  <awp:hasWorkPackageNumber>CWP10001-Equipment
  </awp:hasWorkPackageNumber>
  <awp:hasCategory>Construction_work_package</awp:hasCategory>
  </WorkPackage>

  <WorkPackage rdf:about="&qn1;CWP10002-Equipment">
  <awp:hasManager>Wenchi_Shou</awp:hasManager>
  <awp:hasWorkPackageNumber>CWP10002-Equipment
  </awp:hasWorkPackageNumber>
  <awp:hasCategory>Construction_work_package</awp:hasCategory>
  </WorkPackage>

```

Figure 6-9: A Snippet of the Converted RDF Data Model in RDF/XML Format

### 6.4.3 Document meta-data to RDF

This type of data wrapper is developed for mapping document meta-data into RDF triples. In most LNG projects, documents are always stored in an Electronic Document Management System (EDMS) which provides a solution for managing the creation, capture, indexing, storage, retrieval, and disposition of records (Johnston and Bowen 2005, Adam 2007). Each

document has its own URI and a user-extendable set of meta-data. There are two types of meta-data: internal and external. The former one is normally included in mark-up language documents (i.e. XML and HTML) and embedded within descriptive elements (start and end tags). The latter one exists in all types of documents and is a set of properties that describe a document, such as: "title", "author", "subject", and "date". Dublin Core is the main vocabulary that is used to convert these meta-data into RDF format.

## **6.5 Linked Constraint Data Cloud**

The result of the data transformation is a set of disparate RDF datasets. To fully support the decision making, these disparate resources are required to be interconnected to each other. The objective of linking constraint data in the cloud is to create a global, interconnected data space for cross-domain constraint information sharing and management. In this section, two types of data interconnections are discussed as follows, namely, data interconnection among RDF data sets and data interconnection between RDF triples and documents.

### **6.5.1 Data interconnection among RDF data sets**

The merged ontology developed in Section 5 plays a critical role to set external RDF links among multiple RDF data sets. Technically, such an RDF link is an RDF triple in which the subject of the triple is a URI reference in the namespace of one data set, while the predicate and/or object of the triple are URI references pointing into the namespaces of other data sets (Heath and Bizer 2011). In this study, two types of external RDF links are used for linking the disparate RDF data sets. The first one is relationship link which points at related things in other data sets (Heath and Bizer 2011). For instance, relationship links enable an instance of *SupplyChainConstraint* class (i.e. purchasing a pump) to point to a related instance of *InstallationWorkPackage* class (i.e. installing the pump) which has this constraint, or to an instance of *EngineeringWorkPackage* class which provides required specifications (i.e. specifications and quantities of the pump). The second one is identity link which points at URI aliases used by other data sources to identify the same real-world object or abstract concept (Heath and Bizer 2011). Currently, there is limited agreement on the use of common URIs for the entities across different data sets, which results in multiple URIs identifying the same entity. Expressing equivalences such as *owl:sameAs* can be used to state that entities in different data sets are actually the same, for example, *awp:iwp\_1001\_ec\_pump\_101 owl:sameAs cons:ec\_pump\_101* which means the two entities of *iwp\_1001\_ec\_pump\_101* in AWP data set and *ec\_pump\_101* in Constraint data set are the same world object. When entities are determined to be the same by these associations, information about them from different data sets can be merged.

### 6.5.2 Data interconnection between RDF triples and documents

Data interconnection between RDF triples and documents is significant in cases where the user is aware of a specific term and needs to make a search within the related domain to access certain documents of his interest. For example, a project manager of a contractor firm might be willing to retrieve all the engineering drawings or specifications related to the term “Pump\_101”. Figure 6-10 depicts the architecture of how to interconnect RDF triples and documents. The module of the “Document Meta-data to RDF” developed in Section 6.3 builds the connection between EDMS and RDF Triple Store. For each document in EDMS, there is a corresponding small RDF graph (i.e. several connected RDF triples converted from the document meta-data) in Triple Store. Through the user interface, the user can perform a SPARQL query based on the RDF Triple Store to get a document URI value and using this value to conduct a GET call from the EDMS resource to retrieve the raw document.

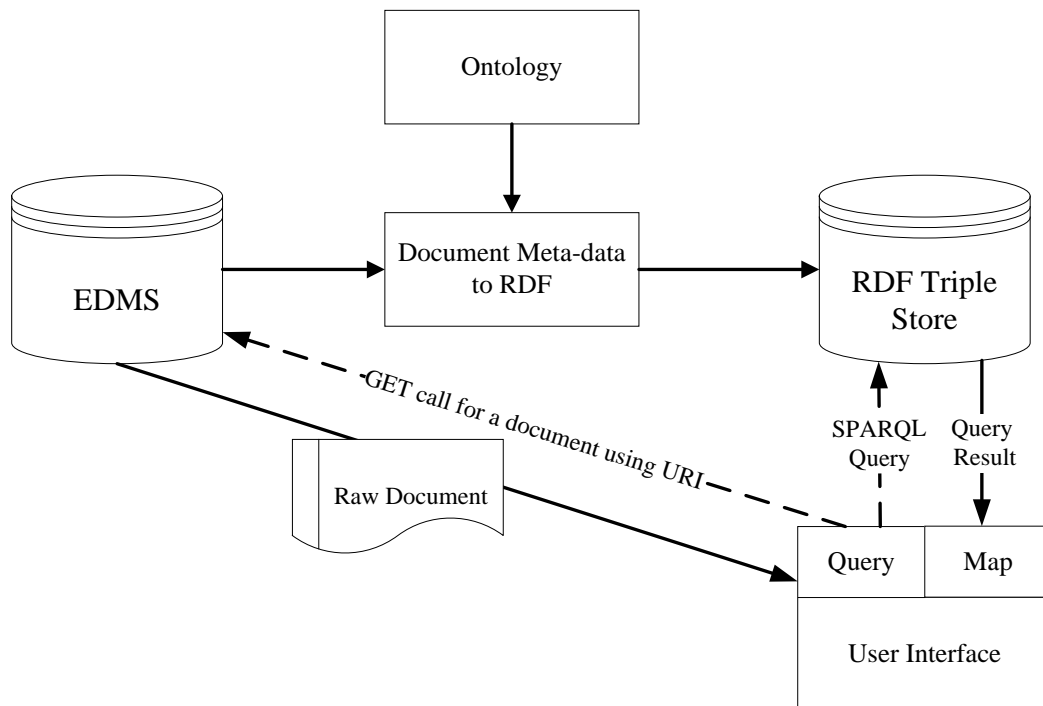

Figure 6-10: Data Interconnection between RDF Triples and Documents

### 6.6 Pilot Case Study

The purpose of this pilot case study is to illustrate how the proposed approach can be implemented in an LNG plant construction project for improving cross-domain constraint information sharing. A real LNG plant module (as shown in Figure 6-11), located in the Australian Centre for Energy and Process Training (ACEPT) was selected as the case because

it suitably represents the complex nature of a modern process plant. The main items contained within the LNG plant module include: a Dehydration Vessel, an Inlet Separator, a Three-Phase Separator, an Exchanger, 50 Pipes, 40 Valves, 25 Gratings, 30 platforms, and 30 columns.



Figure 6-11: A real LNG Plant Module

### 6.6.1 Data preparation and processing

To achieve the objective, four types of data sources (i.e. engineering constraint, supply chain constraint, site constraint, and project planning) with sample data sets were used. The engineering constraint data sets include drawings (i.e. general arrangement, isometric, and plant & instrumentation diagram), sheets (i.e. piping insulation and cable schedule), and specifications. The supply chain constraint data sets contain two procurement lists of pipelines and instruments. The site constraint data sets consist of permits, labour, temporary structures (i.e. scaffolds), and tools. The project planning data was developed by the company of the Fremantle Steel Group using Primavera 6.

First, the sample datasets listed above from the four separate data sources were converted into the RDF files using the proposed three types of data wrappers developed in Section 6.4. These separate RDF data graphs were then interconnected with each other to generate a linked data cloud based on the two types of interconnection methods developed in Section 6.5. The step

of transforming drawing data to RDF was conducted based on the open source of dot15926 editor (TechInvestLab 2015), while the other steps were performed using the Apache Jena Framework (Jena 2015). Figure 6-12 illustrates a snippet of the final linked data cloud in the RDF/XML format. There are 103766 RDF triples in total in this dataset which are enough for demonstrating the capabilities of the proposed approach. However, in a real LNG project, the quantity of the triples is much larger than this number.

```

<!DOCTYPE rdf:RDF [
  <!ENTITY qn4 "http://tpl.rdlfacade.org/data#" >
  ...
]>

<rdf:RDF
  ...
  xmlns:qn4="http://tpl.rdlfacade.org/data#"
  xmlns:pcardl="http://posccaesar.org/rdl/"
  ...
  xmlns:p7tm="http://standards.iso.org/iso/ts/15926/-8/ed-
1/tech/reference-data/p7tm#"
  ...
  xmlns:awp="http://www.owl-ontologies.com/awp.owl#"
  ...
  xmlns:cons="http://www.owl-ontologies.com/cons.owl#"
  ...
>

<rdf:Description rdf:about="&qn3;id=P-ECHO-BV-103">
<pcardl:hasCreationDate>02/27/17</pcardl:hasCreationDate>
<pcardl:hasCreator>JunWang</pcardl:hasCreator>
<rdfs:comment>BUTTERFLY VALVE</rdfs:comment>
<rdfs:label>BV-103</rdfs:label>
...
</rdf:Description>
...

<rdf:Description rdf:about="&qn3;EWP10001-Piping-SG-108">
<rdfs:label>EWP10001-Piping-SG-108</rdfs:label>
<awp:hasManhour>51</awp:hasManhour>
<awp:hasSchedule>
  <rdf:Description>
    <awp:startDate>201-05-28</awp:startDate>
    <awp:finishDate>201-06-21</awp:finishDate>
  </rdf:Description>
</awp:hasSchedule>
<awp:hasRelatedPWP rdf:resource="&qn3;PWP10001-Piping-SG-108" />
<awp:hasEngineeringItem rdf:parseType="Collection">
  <rdf:Description rdf:about="&qn3;IsometricDrawing-Piping-
SG-108"/>
  ...
</awp:hasEngineeringItem>
...
</rdf:Description>
...

<rdf:Description rdf:about="&qn3;MechanicalFitter-Piping-SG-108">
<rdf:type rdf:resource="&cons;Labor"/>
<rdfs:label>MechanicalFitter-Piping-SG-108</rdfs:label>
<awp:hasNumber>2</awp:hasNumber>
...
</rdf:Description>
...

```

**1. ISO 15926 Ontology**

**2. AWP Ontology**

**3. Constraint Ontology**

**4. Engineering Drawing Data**

**5. Work Package Data**

**6. Constraint Data**

Figure 6-12: A Snippet of the Final Linked Data Cloud in the RDF/XML Format

## 6.6.2 Data access and inference

Once these data are linked, query strategies and reasoning rules can be applied to extract specific information based on the objective of the cross-domain constraint information searching and sharing. Data access through SPARQL and information reasoning process is presented in the following sections.

### (1) Data Access

The suite of SPARQL1.1 specification was used in this study to query and update triples and graphs. There are four types of SPARQL queries: SELECT, CONSTRUCT, DESCRIBE, and ASK. A SPARQL SELECT query returns a solution, which is a set of bindings of variables and values. A SPARQL CONSTRUCT query returns triples as a sequence of triple values in a RDF graph. These triples are constructed by substituting variables in a set of triple templates to create new triples from existing triples. A SPARQL DESCRIBE query returns a sequence of triple values as a RDF graph that describes the resources found. A SPARQL ASK query returns a boolean (true or false) indicating whether a query pattern matches the dataset.

### (2) Information Inference

Inference is the process of discovering new facts from existing triples on a set of rules. In this study, a type of automatic inference method was applied which used rulesets and ontologies. New facts can be added to the RDF triple store through forward-chaining inference (Meditkos and Bassiliades 2010), or be inferred at query time through backward chaining inference (Kiryakov et al. 2009, Kolovski et al. 2010). Rulesets utilised in this study included the standard rulesets, such as *rdfs*, *rdfs+* and *OWL-Horst*, and pre-defined rulesets. Users can also create their own rulesets by importing some of these rulesets and/or writing their own rules. Figure 6-13 shows an example of the rule *domain.rules* which states that if all the things in the second set of braces match a triple (*p* has domain *o* - that is, for every triple that has the predicate *p*, the object must be in the domain *o*), then construct the triple in the first set of braces (if you see *s p x*, then *s* is a *o*).

```
PREFIX rdf: <http://www.w3.org/1999/02/22-rdf-syntax-ns>
PREFIX rdfs: <http://www.w3.org/2000/01/rdf-schema/>

...

rule "domain_type" CONSTRUCT {
  ?s a ?o
} {
  ?s ?p ?x .
  ?p rdfs:domain ?o
}
```

Figure 6-13: Example of A “domain\_type” Rule



### 6.6.3 Linked Data applications

With the linked constraint data cloud, three types of applications have been developed including (1) cross-domain constraint information searching, (2) constraint data visualisation, and (3) constraint-related reference data/document searching. Each of them is discussed in detail as follows.

#### Application 1: Cross-domain constraint information searching

This application aims to help project participants quickly find constraint information. Figure 6-14(a) shows an example of using SPARQL Query to search all of the site constraints related to the IWP10001-Piping-SG-108. Users can also narrow down their searching results with some conditions, for instance, users can only ask for the site constraints with the status of “unremoved” (as shown in Figure 6-14(b)). If a project planner tries to list all the constraints of an IWP, including site, supply-chain, and engineering constraints through an SPARQL Query, inference rules are needed due to the lack of directional links between IWPs and engineering/supply-chain constraints in the raw linked constraint data cloud. Figure 6-15(a) shows the two required inference rules. Rule 1 is used for listing all the engineering constraints for a specific work package. The rule sentence itself declares that if we find a triple where *?s awp:hasRelatedEWP ?o* and another triple where *?o awp:hasEngineeringItem ?item*, in addition with the *?item* has a number of members *?member*, we can infer that the work package *?s cons:hasEngineeringConstraint ?member*. Following the same guide, Rule 2 is also developed which aims to list all the supply-chain constraints for a specific work package. Together with the constraint ontology which declares the properties of *cons:hasEngineeringConstraint* and *cons:hasSupplyChainConstraint*, which are sub-classes of *cons:hasConstraint*, we can find all the 13 constraints of the IWP10001-Piping-SG-108 (as shown in Figure 6-15(b)).

Other types of searching may include getting the status/maturity of a specific constraint, list all the constraints within a specific time window, list all the constraints which have maturity values less than 50%, and list all the constraints from a specific sub-contractor.

SPARQL ENDPOINT:  **1. SPARQL Endpoint**

CONTENT TYPE (SELECT):  CONTENT TYPE (GRAPH):

```

17 prefix basens: <http://example.org/rdl/>
18 prefix xsd: <http://www.w3.org/2001/XMLSchema#>
19 prefix pcardl: <http://data.posccaesar.org/rdl/>
20
21
22 SELECT ?Site_Constraint
23 WHERE {
24   qn3:IWP10001-Piping-SG-108 cons:hasSiteConstraint ?object.
25   ?object rdf:rest*/rdf:first ?Site_Constraint.
26 }
27
28 
```

**2. SPARQL Prefix: There are 16 prefixes in total for this study**

**3. SPARQL Query (1)**

QUERY RESULTS

Showing 1 to 4 of 4 entries

Site_Constraint
1 qn3:Scaffold-Piping-SG-108
2 qn3:MechanicalFitter-Piping-SG-108
3 qn3:ElectricalFilter-Piping-SG-108
4 qn3:Permit-Piping-SG-108

**4. Query Results: Four site constraints are found**

Figure 6-14(a): SPARQL Query for Searching All of the Site Constraints Related to *IWP10001-Piping-SG-108*.

SPARQL ENDPOINT:

CONTENT TYPE (SELECT):  CONTENT TYPE (GRAPH):

```

17 prefix basens: <http://example.org/rdl/>
18 prefix xsd: <http://www.w3.org/2001/XMLSchema#>
19 prefix pcardl: <http://data.posccaesar.org/rdl/>
20
21
22 SELECT ?Site_Constraint
23 WHERE {
24   qn3:IWP10001-Piping-SG-108 cons:hasSiteConstraint ?object.
25   ?object rdf:rest*/rdf:first ?Site_Constraint.
26   ?Site_Constraint cons:status "unremoved".
27 }
28
29 
```

**SPARQL Query (2)**

QUERY RESULTS

Showing 1 to 2 of 2 entries

Site_Constraint
1 qn3:Scaffold-Piping-SG-108
2 qn3:Permit-Piping-SG-108

**Query Results: two "unremoved" site constraints are found**

Figure 6-14(b): SPARQL Query for Searching All of the Unremoved Constraints Related to the *IWP10001-Piping-SG-108*

**Inference Rule 1:**

```
[ruleListALLTheEngineeringConstraints: (?s awp:hasRelatedEWP ?o ) (?o awp:hasEngineeringItem ?item) (?item rdf:rest*/rdf:first ?member) -> (?s cons:hasEngineeringConstraint ?member)
```

**Inference Rule 2:**

```
[ruleListALLTheSupplyChainConstraints: (?s awp:hasRelatedPWP ?o ) (?o awp:hasProcurementItem ?item) (?item rdf:rest*/rdf:first ?member) -> (?s cons:hasSupplyChainConstraint ?member)
```

Figure 6-15(a): Inference Rules for Listing All the Constraints

SPARQL ENDPOINT:  CONTENT TYPE (SELECT):  CONTENT TYPE (GRAPH):

```
23  
24 SELECT ?constraint  
25 WHERE {  
26   ?subject rdfs:label "IWP10001-Piping-SG-108".  
27   ?subject cons:hasConstraint ?object.  
28   ?object rdf:rest*/rdf:first ?constraint.  
29 }  
30
```

**SPARQL Query (3): Find all of the constraints related to IWP10001-Piping-SG-108, and list each of them**

QUERY RESULTS  
Table Raw Response  
Showing 1 to 13 of 13 entries Search:  Show 50 entries

constraint	
1 qn3:ElectricalFitter-Piping-SG-108	Site constraints
2 qn3:id=P-Echo-HV-104	Supply-chain constraints
3 qn3:id=P-Echo-HV-106A	
4 qn3:id=P-Echo-HV-106B	
5 qn3:id=P-Echo-TT-114	
6 qn3:id=P-Echo-VAL-122	
7 qn3:id=P-Echo-VAL-123	
8 qn3:IsometricDrawing-Piping-SG-108	
9 qn3:MechanicalFitter-Piping-SG-108	Site constraints
10 qn3:Permit-Piping-SG-108	
11 qn3:ProcessInstrumentationDiagram-Piping-SG-108	Engineering constraints
12 qn3:Scaffold-Piping-SG-108	Site constraints
13 qn3:Specification-Piping-SG-108	Engineering constraints

Figure 6-15(b): SPARQL Query for Searching All the Constraints Related to the *IWP10001-Piping-SG-108*

## Application 2: Constraint data visualisation

This application aims to visualise the linked constraint data cloud especially for the query results visualisation. The Semantic Web Importer Plugin (Demairy 2017) was utilised in this study to query an SPARQL endpoint and represent the result as a graph in Gephi (Bastian et al. 2009). The URL of “*http://localhost:3030/JunWang/query*” was selected as the remote SPARQL Endpoint (as shown in Figure 6-16(a)). Figure 6-16(b) illustrates a subset data visualisation which covers all the directional links and nodes to the *IWP10001-Piping-SG-108*. From the graph, project participants can efficiently identify the site constraints, and related EWPs and PWPs of the *IWP10001-Piping-SG-108*. The basic information of the work package itself can be also recognised, such as *Creator*, *Creation Date*, *Start Date* and *Finish Date*, and *Required Man-hours*.

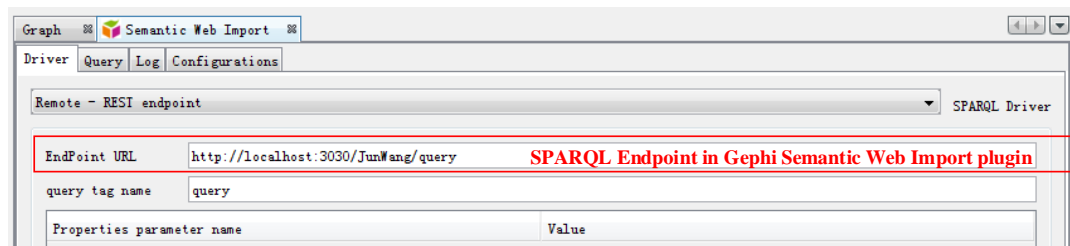

Figure 6-16 (a): Setup a Remote REST SPARQL Endpoint in the Gephi Semantic Web Import Plugin

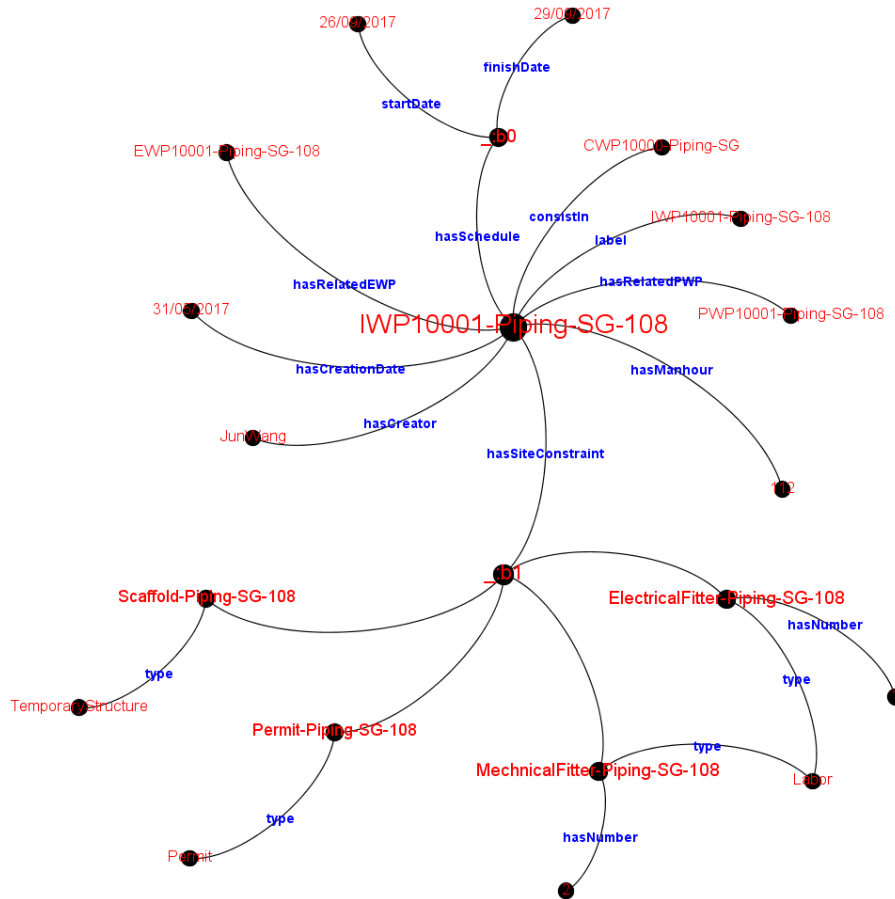

Figure 6-16 (b): Data Visualisation of the *IWP10001-Piping-SG-108*

### Application 3: Constraint-related Reference Data/Document Searching

This application aims to help project participants obtain additional data/documents for a specific constraint through SPARQL queries. In real projects, the general contractor or sub-contractors need to know not only the status but the detailed raw documents of each constraint. The former one can help them develop their weekly/daily plans while the latter one guides them to execute their work correctly.

With regards to the reference data, in this study, a public data set named POSC Caesar Association Reference Data Library (PCA-RDL), was linked to our constraint data cloud. In terms of the reference document linking, all of the documents for this pilot study, such as isometric drawings, design specifications, and permits were stored in a Dropbox account which can be treated as a simplified document management system. Each document stored in the Dropbox has a unique URL which is used as the range of the property of *awp:docLink* within the linked constraint data cloud.

A scenario of searching engineering constraints and their corresponding reference data and documents is formulated. Figure 6-17 (a) illustrates the SPARQL Query of listing all the engineering constraints of the *IWP10001-Piping-SG-108*. Detailed information of the constraint of “*qn3:IsometricDrawing-Piping-SG-108*” is queried in Figure 6-17 (b). The query results include the raw engineering document links and their types. Project participants can simply look up these resources by dereferencing the corresponding URIs over the HTTP protocol. Figure 6-17 (c) shows the dereferenced result of the URI: “*https://www.dropbox.com/s/qa4b4k6fjmjxuup/4416DP09.pdf?dl=0*”, which is an isometric drawing named 4416DP09 in PDF format. Figure 6-17 (d) shows the dereferenced result of the URI: “*pcardl:RDS331559* (i.e. *http://data.posccaesar.org/rdl/RDS331559*)”, which indicates the document type is a “*PIPING ISOMETRIC DRAWING*” defined in the PCA-RDL.

The screenshot shows a SPARQL query interface with the following components:

- SPARQL ENDPOINT:** `http://localhost:3030/JunWang/query`
- CONTENT TYPE (SELECT):** JSON
- CONTENT TYPE (GRAPH):** Turtle
- Query Text:**

```

19 prefix pcardl: <http://data.posccaesar.org/rdl/>
20
21
22 SELECT ?Engineering_Constraint
23 WHERE {
24   qn3:IWP10001-Piping-SG-108 awp:hasRelatedEWF ?object.
25   ?object awp:hasEngineeringItem ?engineeringItem.
26   ?engineeringItem rdf:rest*/rdf:first ?Engineering_Constraint.
27
28
29 }
30

```
- SPARQL Query Annotation:** **SPARQL Query: Find all of the engineering constraints related to IWP10001-Piping-SG-108, and list each of them**
- QUERY RESULTS:**
  - Buttons: Table (selected), Raw Response, Download
  - Showing 1 to 4 of 4 entries
  - Search:
  - Show 50 entries
  - Table Header: Engineering\_Constraint
  - Results:
    - 1 [qn3:IsometricDrawing-Piping-SG-108](#) **Detailed information of this constraint is searched in Figure 6-17(b)**
    - 2 [qn3:ProcessInstrumentationDiagram-Piping-SG-108](#)
    - 3 [qn3:Specification-Piping-SG-108](#)
    - 4 [qn3:ThreeDimensionModel-Piping-SG-108](#)

Figure 6-17 (a): SPARQL Query for Searching All the Engineering Constraints Related to the *IWP10001-Piping-SG-108*

SPARQL ENDPOINT:  CONTENT TYPE (SELECT):  CONTENT TYPE (GRAPH):

```

18 prefix xsd: <http://www.w3.org/2001/XMLSchema#>
19 prefix pcardl: <http://data.posoccaesar.org/rdl/>
20
21
22 SELECT ?Isometric_Drawing_Link ?type
23 WHERE {
24   qn3:IsometricDrawing-Piping-SG-108 swp:docLink ?doc.
25   ?doc rdf:rest*/rdf:first ?Isometric_Drawing_Link.
26
27   qn3:IsometricDrawing-Piping-SG-108 rdf:type ?type.
28
29
30 }

```

**SPARQL Query: Find the raw documents of the constraint of "IsometricDrawing-Piping-SG-108", and its type**

QUERY RESULTS

Table Raw Response

Showing 1 to 4 of 4 entries

Isometric_Drawing_Link	type
<a href="https://www.dropbox.com/s/qa4b4k6fjmxuup/4416DP09.pdf?dl=0">https://www.dropbox.com/s/qa4b4k6fjmxuup/4416DP09.pdf?dl=0</a>	pcardl:RDS331559
<a href="https://www.dropbox.com/s/70w3ilbe4mhapoa/4416DP10A.pdf?dl=0">https://www.dropbox.com/s/70w3ilbe4mhapoa/4416DP10A.pdf?dl=0</a>	pcardl:RDS331559
<a href="https://www.dropbox.com/s/2bzvt9mti2naoij/4416DP10B.pdf?dl=0">https://www.dropbox.com/s/2bzvt9mti2naoij/4416DP10B.pdf?dl=0</a>	pcardl:RDS331559
<a href="https://www.dropbox.com/s/ttqvbrdp9ubwzgj/4416DP11.pdf?dl=0">https://www.dropbox.com/s/ttqvbrdp9ubwzgj/4416DP11.pdf?dl=0</a>	pcardl:RDS331559

**The link will go to the raw document (as shown in Figure 6-17(c))**

**The link will go to the external reference data library (as shown in Figure 6-17(d))**

Figure 6-17 (b): SPARQL Query for Searching Additional Information of the Engineering Constraint of *IsometricDrawing-Piping-SG-108*

 4416DP09.pdf **This document ID/Link is same as the ID/Link in the Query Results of Figure 6-17(b)**

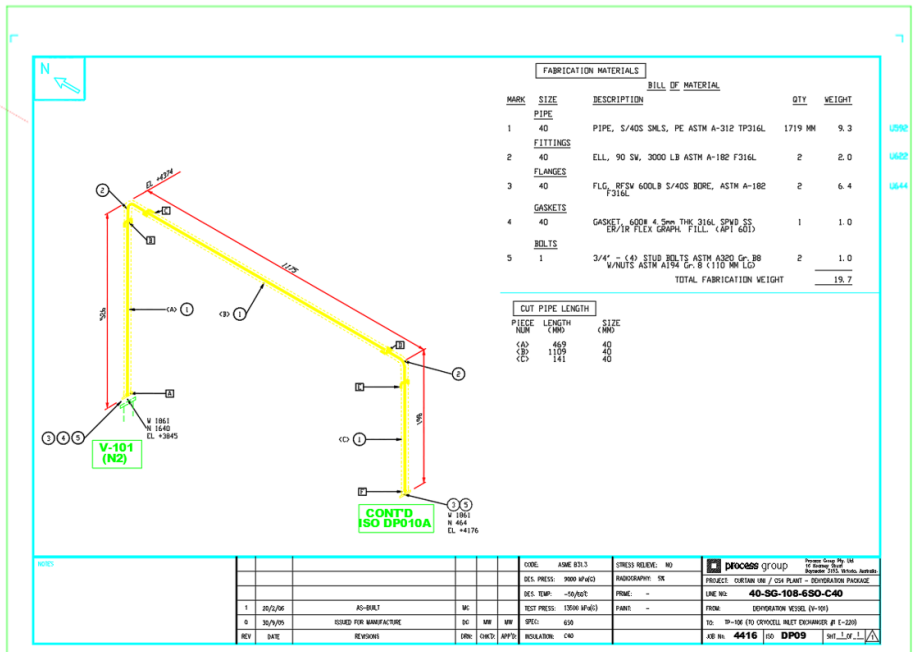

**FABRICATION MATERIALS**

MARK	SIZE	DESCRIPTION	QTY	WEIGHT
<b>PIPE</b>				
1	40	PIPE, S/40S SMLS, PE ASTM A-312 TP316L	1719	9.3
<b>FITTINGS</b>				
2	40	ELL, 90 SW, 3000 LB ASTM A-182 F316L	2	2.0
<b>FLANGES</b>				
3	40	FLG, RF SW 600LB S/40S BORE, ASTM A-182 F316L	2	6.4
<b>GASKETS</b>				
4	40	GASKET, 600# 4.5mm THK 316L SPND SS ER/1R FLEX GRAPH. FILL (API 601)	1	1.0
<b>BOLTS</b>				
5	1	3/4" - (4) STUD BOLTS ASTM A320, Gr. B V/NUTS ASTM A194 Gr. B (110 MM Lg)	2	1.0
			<b>TOTAL FABRICATION WEIGHT</b>	<b>19.7</b>

**CUT PIPE LENGTH**

PIECE	LENGTH (MM)	SIZE (MM)
CA	459	40
CB	1159	40
CC	141	40

**NOTES**

1	20/02/06	AS-BUILT	WC	WR	WR	SPCL	600	FROM: (EQUIPMENT VESEL (E-101))
0	30/01/05	ISSUED FOR MANUFACTURE	DC	WR	WR	SPCL	600	TO: 10-100 (TO CIRCULAR INLET DIAMETER # 1-220)
REV	DATE	REVISION	DRG	CHKD	APPD	REGULATION	CND	

**PROCESS FOUND**

PROJECT: 40-SG-108-ES0-C40  
 LINE NO.: 40-SG-108-ES0-C40  
 FROM: (EQUIPMENT VESEL (E-101))  
 TO: 10-100 (TO CIRCULAR INLET DIAMETER # 1-220)  
 JOB NO. 4416 DP09

Figure 6-17 (c): Raw Isometric Drawing

## PIPING ISOMETRIC DRAWING

<http://data.posccaesar.org/rdl/RDS331559>

This ID is same as the ID in the Query Results of Figure 6-17(b))

<b>rdl:defaultRdsId</b>	R50734018068
<b>rdl:hasCreationDate</b>	2000.11.03
<b>rdl:hasCreator</b>	u82237
<b>rdl:hasDefinition</b>	A drawing which is a schematic center-line representation of a piping system drawn according to the ISO ??? specification, excluding the graphical representation of the components. It includes basic information about pipes, valves, fittings, welds etc. and how they are interconnected and located using a 2D or 3D co-ordinate system.
<b>rdl:hasDesignation</b>	PIPING ISOMETRIC DRAWING
<b>rdl:hasDesignationAb..</b>	3459900
<b>rdl:hasIdPCA</b>	RDS331559
<b>rdl:hasStatus</b>	Recorded
<b>rdf:type</b>	owl:NamedIndividual p2:ClassOfInformationObject
<b>rdfs:label</b>	PIPING ISOMETRIC DRAWING
<b>owl:sameAs</b>	<a href="http://posccaesar.org/rdl/RDS331559">http://posccaesar.org/rdl/RDS331559</a>

Figure 6-17 (d): External Reference Data Library

### 6.6.4 Evaluations and limitations

The accuracy of the SPARQL Query results from the above three applications was evaluated by comparing with the facts from the raw project sample data. The result shows that the query accuracy is 100%. In order to improve the confidence level, another 5 IWPs were randomly selected from the rest 40 IWPs including: *IWP10001-Piping-HC-118*, *IWP10001-Piping-PL-124*, *IWP10001-Piping-VF-138*, *IWP10001-Piping-SG-137*, and *IWP10001-Piping-MW-103*. Similar SPARQL Queries were conducted and the query accuracy was calculated accordingly. All of the query results were checked manually and the accuracy was still 100%.

According to the results of the simple evaluation, the proposed linked data-enabled approach can assist project planners in (1) interlinking constraint data from fragmented and heterogeneous data sources; (2) finding constraint information for specific work packages by a simple search; (3) inferring new constraint relationships with predefined reasoning rules; and (4) visualising constraint data sets.

This research is limited to the small size of the data and the low complexity of the LNG module. In addition, in order to simplify the pilot case study, the Dropbox is used as the document management system instead of various commercial platforms such as M-Files, Alfresco, and



OnBase. The Excel is used as the database for store the raw project data including work packages (e.g. ID, Name, Type, Creator, etc.), scheduling data, and constraint data. In the future, the proposed approach especially the RDF data transformation methods should be further enhanced so that data stored in the existing document management systems and/or databases can be automatically converted to RDF format.

## **6.7 Conclusions**

In this chapter, a linked data-enabled platform was developed for improving cross-domain constraint information sharing in LNG construction, which includes: (1) two newly developed ontologies: constraint ontology and AWP ontology; (2) three types of RDF data transformation methods: Drawing data to RDF, Table data to RDF, and Document meta-data to RDF; and (3) two types of data interconnection methods: data interconnection among RDF data sets, and data interconnection between RDF triples and documents. A pilot case study was conducted to demonstrate the capability of the proposed approach. The results show that the proposed approach can successfully interlink constraint data from multiple sources, efficiently extract and visualise a subset of the linked constraint data cloud, and infer extra information with predefined reasoning rules and ontologies.

## **Chapter 7: A Coordinated Approach for Supply-chain Constraint Tracking in LNG Industry**

### **7.1 Introduction**

Chapter 7 proposes a framework of a coordinated approach towards supply-chain constraint tracking in LNG construction (i.e. *Research Objective 4*). The framework was developed according to the discussion results of the two focus group studies (i.e. *Focus Group Study 2&3* explained in Section 3.2.1, Chapter 3). Three main elements are developed within the proposed framework: (1) Supply-chain constraint tracking for general materials; (2) Supply-chain constraint tracking for project-specific materials; and (3) A supply-chain constraint control platform. Two field experiments (i.e. *Field Experiment 1&2* explained in Section 3.2.2, Chapter 3) were conducted in the field to evaluate the feasibility of the proposed approach.

### **7.2 Tracking Technologies Selection**

A typical supply chain in LNG construction contains three main stages (i.e. off-site fabrication, shipping & delivery, and construction site logistics) and fifteen sub-processes (as shown in Table 7-1). The forth column of Table 7-1 shows the *Types of the objects to be tracked* in each process. It is very straightforward to decide the objects in processes of number 1, 5-15. However, for the processes of number 2-4 (i.e. Programming & Processing, Cutting & Drilling, and Welding), it is difficult because there is either no physical components or massive small steel pieces inside the processes. According to the fabricator's suggestion, shop drawings can be treated as the objects to reflect the status of the three processes. The reasons are threefold: (1) the fabrication plan is developed based on the shop drawings; (2) workers need to reference the shop drawings frequently so as to finish their tasks; and (3) the shop drawings are always transferred from the end of the last process to the next one.

Tag removal is another significant factor needed to be considered during field execution. It is ideal to attach tag once and keep it through the project lifecycle. However, in the following three situations, tags should be considered to be removed: (1) the physical tags will have a negative impact on the quality of the following processes, such as surface treatment; (2) massive tags are attached within one large module which would reduce the efficiency of searching a right tag to be scanned during the following processes. For instance, large LNG offsite modules always start from small components or modules, and end with several times of assemblies; (3) the price of the tags is so high that they need to be reused so as to lower the hardware cost for each implementation.

Feasibility assessment of the four alternative tracking solutions is critical to the effectiveness of the proposed framework. A detailed comparison of four technologies has been conducted (as shown in Table 7-2). When compared with passive RFID, barcode is more convenient to be generated and implemented in a real project. In addition, barcode is much cheaper than passive RFID (Qian et al. 2012). However, passive RFID is more powerful in terms of tracking capability, such as ruggedness, reliability, data storage and read speed. Considering the five factors for each detailed process, barcode and RFID are feasible for tracking all processes in the stages of offsite fabrication and construction site logistics. Although both technologies cannot directly record the location information, there are two indirect approaches. The first one is GPS-enabled locating which relies on the GPS data from the mobile reader. If the GPS data is within any of the predefined location areas, the mobile reader can automatically set the predefined location to the scanned barcode. Predefined locations should be assigned to a rectangular area (geo-fence) using four GPS Coordinates (top left, top right, bottom left, bottom right). If the predefined location is not assigned a geo-fence, the second method can be used. The user can manually choose a predefined location for a component if needed.

Table 7-1: Tracking Technology Selection for Each Process (Items with \* are explained in detail in the Section 7.2)

Stages	Detailed processes		Factors					Feasibility of the alternative tracking solutions				Suggested tracking solutions*
	No.	Name	(1) Types of the objects to be tracked*	(2) Indoor or Outdoor	(3) Line of sight required	(4) Location required	(5) Tags removal *	(a) Barcode	(b) Passive RFID	(c) Active RFID	(d) GPS	
Offsite fabrication	1	Shop Detailing	Drawings	Indoor	Yes	No	No	√	√	×	×	(a)
	2	Programming & Processing	Drawings*	Indoor	Yes	No	No	√	√	×	×	(a)
	3	Cutting & Drilling	Drawings*	Indoor	Yes	Yes	No	√	√	×	×	(a)
	4	Welding	Drawings*	Indoor	Yes	Yes	No	√	√	×	×	(a)
	5	Surface Treatment	Components after welding	Indoor	Yes	Yes	Yes/No *	√	√	√	×	(a) or (b)
	6	Pre-assembly	Components after treatment	Indoor	Yes	Yes	Yes/No *	√	√	√	×	(a) or (b)

	7	Ready for Delivery	Final goods	Outdoor	No	Yes	No	√	√	√	√	(b), (c) or (d)
Shipping & delivery	8	Alongside Ship	Trucks	Outdoor	No	Yes	No	×	×	×	√	(d)
	9	On Board	Ships	Outdoor	No	Yes	No	×	×	×	√	(d)
	10	Ship's Arrive	Ships	Outdoor	No	Yes	Yes/No *	×	×	×	√	(d)
	11	Goods Unloaded	Trucks	Outdoor	No	Yes	No	×	×	×	√	(d)
	12	Arrival Onsite	Trucks	Outdoor	No	Yes	No	×	×	×	√	(d)
Construction site logistics	13	Warehouse	Goods	Indoor	No	Yes	No	√	√	√	×	(a),(b) or (c)
	14	Laydown Yard	Goods	Outdoor	No	Yes	No	√	√	√	√	(c) or (d)
	15	Installation	Goods	Outdoor	No	Yes	Yes/No *	√	√	√	√	(c) or (d)

Table 7-2: Comparison of the Barcode, Passive RFID, active RFID and GPS Tags

	Barcode	Passive RFID	Active RFID	GPS
Ruggedness	low	medium	high	high
Reliability	Wrinkled or smeared labels will not be read	Nearly flawless read rate	flawless read rate	flawless read rate
Tag size	Small	Medium	Medium (varies depending on application)	Large
Tag battery	No	No	Yes	Yes
Orientation dependence	Yes	No	No	No
Communication range	Very short, must be line of sight	Short (3m or less)	Long (100m or more)	Very long
Data collection	Manually scan	Passive (via portals and smart shelves)	Active (via portals)	Active (via cellular or satellite)
Read speed	Slow	Medium	Fast	Fast
Data storage	< 20 characters with linear	Small read/write data (e.g. 128 bytes)	Medium read/write data (e.g. 128 KB) with sophisticated data search and access capabilities	Large read/write data with either a memory card slot, or internal flash memory card and a USB port.
Updateable	No	Yes	Yes	Yes
Simultaneous scanning of multiple codes/tags	No	Yes	Yes	Yes
Cost per tag (\$)	0.01	0.05-1.00	5-30	100 or more

Fixed infrastructure cost	No	low	high	No
Tag/sensor capability	Ability to read and transfer tag values only when tag is scanned by reader; no date/time stamp	Ability to read and transfer sensor values only when tag is powered by reader; no date/time stamp	Ability to continuously monitor and record sensor input; data/time stamp for sensor events	Ability to continuously monitor and record sensor input; data/time stamp for sensor events
Best area of use	Tracking small objects and low-value assets	Tracking within a building or a facility	Tracking within a large area (i.e. construction site)	Tracking within a geographical area or tracking transoceanic shipments and very high-value assets

In shipping and delivery stage, the ability to continuously monitor and record sensor input is necessary. This is why both barcode and passive RFID are supposed to be infeasible. Although active RFID has the ability, it is impossible to set up massive portals across a geographical area, let alone for transoceanic shipments. GPS technology is nominated as a feasible approach because of its continuous location tracking abilities and easy implementation with no additional infrastructure requirement.

Due to the large size of the active RFID and GPS tags, both of them are not applicable to track the processes of shop detailing, programming and processing, cutting and drilling, and welding, because it is difficult to attach these two types of tags to a drawing. GPS technology is also infeasible in tracking processes of surface treatment, pre-assembly, and warehouse management because it is unable to record location information in an indoor environment.

The last column of Table 7-1 illustrates the suggested tracking solutions for each process. Cost-effectiveness and easy implementation are the two main selection criteria. Barcode has dominated advantages to track the processes of 1 to 4 because it can be designed and printed together with the drawings. GPS technology is suggested to track the five processes within the

shipping and delivery stages because most of the shipments are transoceanic in LNG industry and can take several weeks or months to deliver. It should be noted that the detection windows of GPS signal can vary from half days, one day to one week, depending on the scale of traveling distance and the frequency of the report needed. In the other processes, there are at least two options. Usage of either barcode or passive RFID is mostly dependent on the value of the assets. Compared with active RFID, passive RFID is preferred to perform tracking within a building or a facility (i.e. warehouse) while active RFID is utilised to track assets within a large outdoor area with location information requirement, such as tracking instruments or pipe spools in an onshore LNG construction site.

### **7.3 Framework of A Coordinated Approach for Supply-chain Constraint Tracking in LNG Construction**

Figure 7-1 shows the proposed framework for supply-chain constraint tracking in LNG construction. There are three modules within the framework: (1) Supply-chain constraint tracking for general materials, which is a cycling process that will occur more than once as the project progresses; (2) Supply-chain tracking for project-specific materials, which is always a one-off process and needs to be well managed and controlled because any delays will have a big impact on project construction; and (3) Supply-chain constraint control platform, which can integrate all the data collected from various tracking technologies (i.e. GPS, barcode, and RFID) so as to visualise constraint statuses and calculate the deviations between as-planned and as-actual constraint-removal schedules. The details of each part are discussed in the subsequent sections.



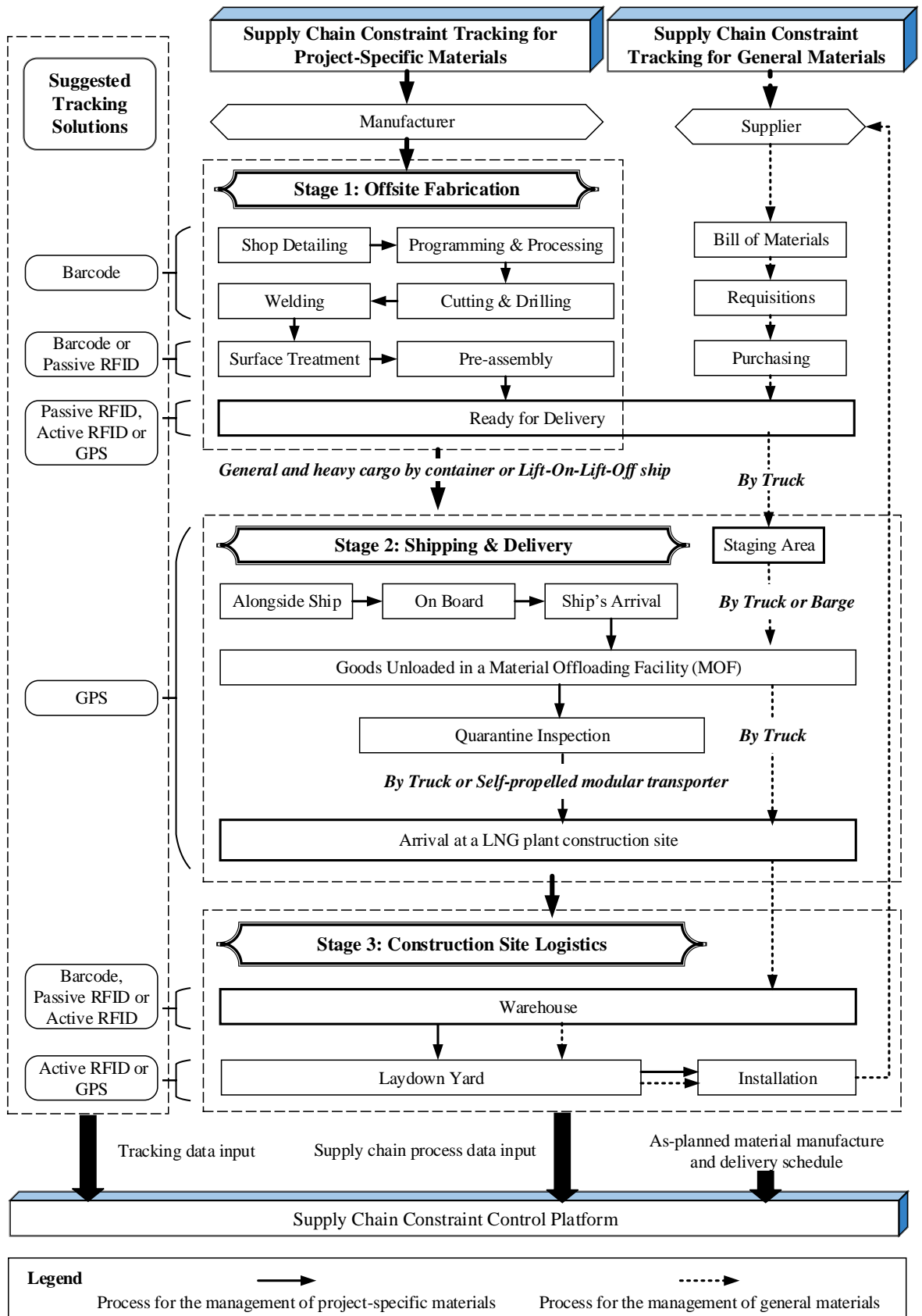

Figure 7-1: Framework of a Coordinated Approach for Supply-Chain Constraint Tracking in LNG Construction

### **7.3.1 Supply-chain constraint tracking for general materials**

There are five main processes needed to be tracked during general-materials management, namely Bill of Materials (BOM), Requisitions, Purchasing, Shipping and Delivery, and Warehouse and Installation. From engineering documents, BOM is generated and presents the demands of materials items. The purchaser needs to summarize all the materials requirements into requisitions, then goes to the purchasing process which is to basically buy the materials from suppliers. When all the materials are ready for delivery, shipment is the next process and needs to be well organized so as to make sure the delivery to site warehouse is at the right time. A staging area is used for staging materials from an initial storage location to construction storage location. Material staging is necessary for the general materials which are staged irrespective of construction orders.

Changes are very common during LNG plant construction due to design alterations, material damages, and missing items, which are revolving around the five processes in a circle for the material supply-chain. All the processes need to be compared and analysed all the time so as to avoid materials surplus or shortages. For example, if the purchaser wants to analyze how much materials are needed, he needs to check the engineering drawings or the BOMs, and know how much in the requisitions and site warehouse, and how much is damaged during shipping for the latest procurement.

### **7.3.2 Supply-chain constraint tracking for project-specific materials**

Project-specific materials mainly refer to offsite fabricated LNG modules. Three stages have been developed for managing the total material supply chain: offsite fabrication, shipping and delivery, and construction site logistics (as shown in Figure 7-1). There are seven processes in Stage 1 which start from shop detailing and end with ready for delivery. Completed shop drawings are transferred from shop detailing to welding. After welding, welded components will be sent out for surface treatment or pre-assembly if required. When ready for delivery, small individual components are always needed to be packaged into a single pallet.

After the fabrication process, five milestones are designed in Stage 2 for the shipping progress tracking, namely (1) alongside ship, (2) on board, (3) ship's arrival, (4) goods unloaded in a material offloading facility, and (5) arrival at a construction site. If the vessel is ready to be shipped, a fabricator is required to notice the owner to arrange the shipment. After the vessel is transported to a harbor, which is typically a milestone, the vessel is considered as alongside the ship. The next milestone is to ensure the boarding of the vessel. In a Free On Board contract, suppliers are responsible for the two milestones. When the ship arrives at the destination harbor, the third milestone is achieved. Owners need to arrange trucks for the unloading of

goods and transferring them to a construction site. If the construction sites of the LNG plants are in the area of Nature Reserve, another milestone of quarantine inspection is necessary to be incorporated after goods are unloaded.

All construction tasks related to site logistics can be categorised into three main types: transportation, search and identification, and layout arrangement. Transportation represents all kinds of activities related to the movement of construction materials, equipment and personnel among warehouses, laydown yard and final installation area. Material search and identification represent all the activities related to the check points such as discovering the delivered goods, determining the construction status, and evaluating the construction performance. The layout arrangement represents the planning activities related to determine the construction resource distribution. Based on different features of logistics tasks, all work tasks among site related logistics require different tracking approaches. They should be adopted based on the availability of human presence and the efficiency of information collection.

### **7.3.3 Supply-chain constraint control platform**

The supply-chain constraint control platform combines three-dimensional (3D) computer-aided design (CAD) models with as-planned supply-chain constraint information and as-actual tracking data. The purpose of this platform is to visualise all the constraint statuses, and detect any potential conflicts between supply-chain constraint-removal plans and construction plans. Decisions can be made in a timely fashion when there are variances detected between the plans and actuals. Data provided by various tracking technologies and 3D CAD can significantly improve and speed up the process of constraint monitoring and deviation analysis.

## **7.4 Experiments and Results**

It is difficult to test all the suggested tracking solutions for the two types of the supply-chain constraints (i.e. project-specific and general materials). Considering the major impact of the project-specific materials (i.e. any delays will result in significant cost and time overruns), the validation of the proposed framework for the general material tracking will not be covered in this research. Two field experiments were conducted to validate the feasibility and efficiency of the proposed coordinated approach for project-specific material tracking: the first experiment covered the whole process tracking during Stage 1 (i.e. offsite fabrication), and the second one focused on the process tracking during Stage 2 and 3 (i.e. shipping and delivery, and construction site logistics).

Based on the benefit of easy implementation and not interrupting the normal production work, barcode was implemented in the first experiment. In the second experiment, active RFID was

selected for site logistics tracking because there had been several examples for using barcode or passive RFID for warehouse management and it was not necessary to repeat the work. GPS was also tested for shipping and delivery tracking.

In order to visualise the statuses of the supply chain constraints, three plugins based on a 3D platform have been developed for barcode, RFID and GPS data reading, configuration, mapping and synchronisation. Figure 7-2 illustrates the architecture of the system integration. All the tracking data, including the received scanning records of barcodes and signals from GPS and RFID tags, will be collected to the web portals. For example, the transportation status of material can be monitored in a geographical-level map by retrieving GPS signals through time. Furthermore, the RFID signals of every site component tagged with an active RFID tag can be collected. The triangulation processes can then be performed in near real-time in order to determine the position information of the components. Navisworks software (Autodesk 2017b) is selected as the basis of the 3D environment, and the web-based APIs are applied to transfer data from the web portals to the 3D platform. By integrating all the tracking data into a 3D virtual plant environment, the status information of the corresponding supply-chain constraints can be visualised and color-coded. Through the comparison of the tracking data and the as-planned constraint-removal schedule, all situations, including delays, can be dynamically captured. The results can be further used to notify site managers or crews by Short Message Service on short notice. Progress reports (i.e. items completed, items dispatched, items delivered, and items installed) are generated from the web portals while the overall S-curve graphs are from the 3D platform.

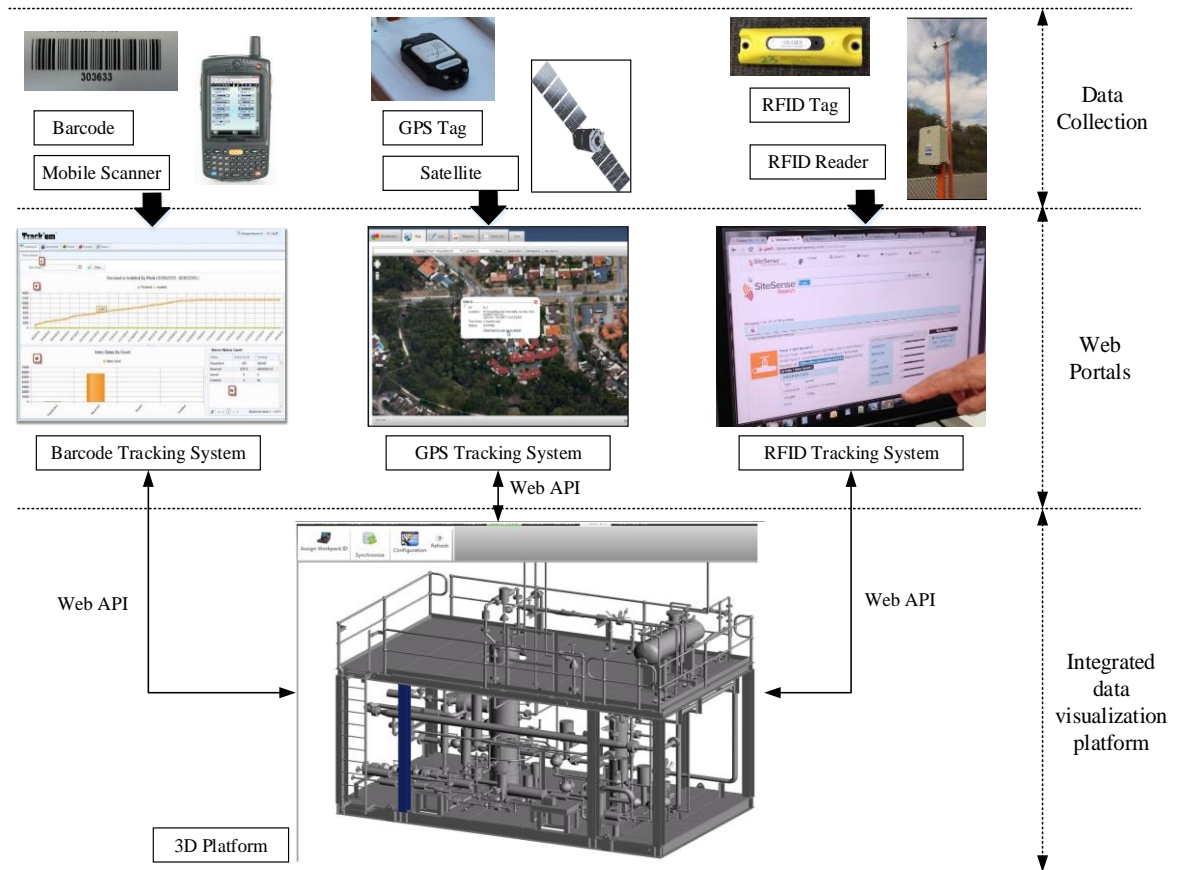

Figure 7-2: Architecture of the Proposed Supply-Chain Constraint Control Platform

#### 7.4.1 Experiment one: offsite fabrication tracking

Through a research agreement with Fremantle Steel Group, the participants were granted access to the fabrication facilities which utilise state of the art Computerized Numerical Control equipment in a combined covered workshop space of 36,000 square meters and can produce over 40,000 tonnes of fabricated steelwork annually. Pre-assembly and laydown areas of 60,000 square meters with mobile cranes up to 350-tonne lifting capacity enable the pre-assembly of large modules and storage of large volumes of fabricated steelwork to suit customer delivery schedules.

##### (1) Experiment design

Two steel columns and one beam from a real construction project were selected as the tracking objects from cutting and drilling to ready for delivery. Detailed manufacturing activities and their corresponding locations are defined in Table 7-3. In order to calculate the overall fabrication progress, the weight for each activity was also added. The weight coefficient was determined based on the existing practices and validated by the project manager. Moreover, the same weight coefficient was also applied in the real project for measuring production

progress. Five zones were recognised based on the fabrication processes and their geographical locations are shown in Figure 7-3.

Fabrication started with cutting and drilling of standard steel plates in Zone 1 and then went to Zone 2 for assembly and welding. As the three selected components all needed to be painted, hence, after welding, they were transferred to Zone 3 for surface treatment. The next step was returning them back to Zone 4 for pre-assembly. At the end, the finished products would be moved to Zone 5 for temporary store purpose, and ready for delivery if necessary.

Table 7-3: Activities during Fabrication and Their Corresponding Locations and Weights for Progress Calculation

<b>Activities</b>	<b>Locations</b>	<b>Progress</b>
Cutting and Drilling	Zone 1	20%
Assembly	Zone 2	24%
Welding	Zone 2	24%
Surface Treatment	Zone 3	15%
Pre-assembly	Zone 4	15%
Ready for Delivery	Zone 5	2%

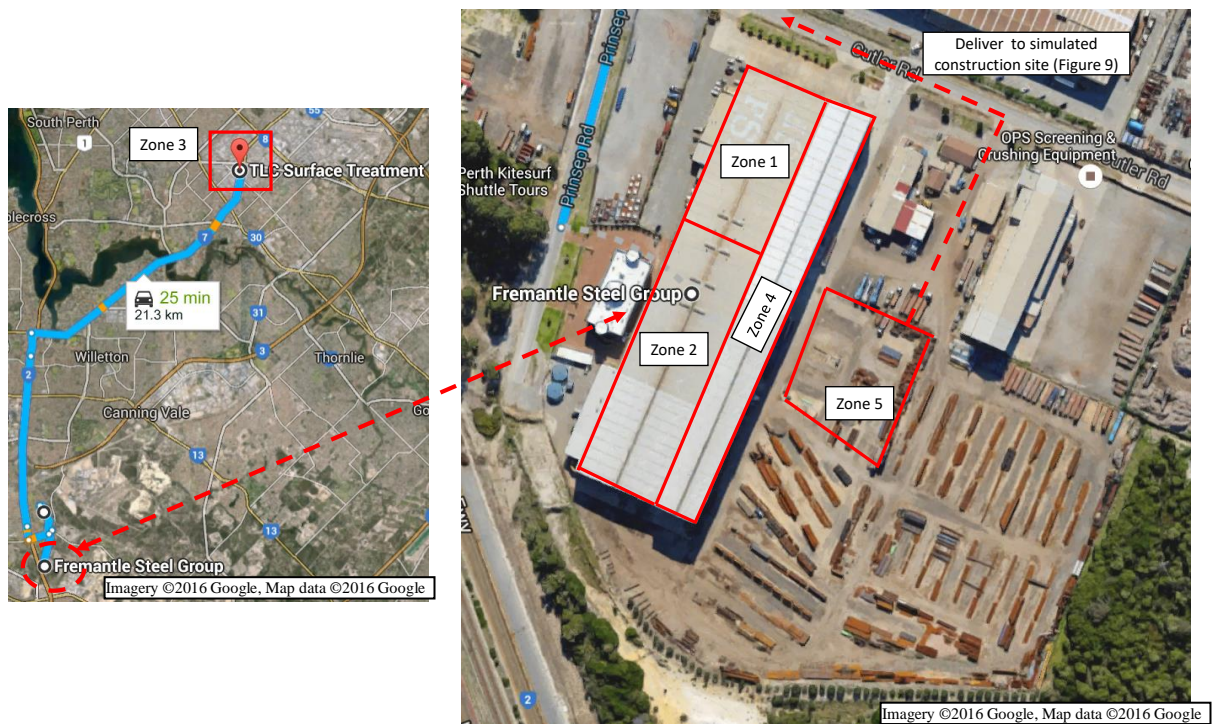

Figure 7-3. Location Definition for Fabrication Tracking

## (2) Barcoding technology implementation

Five different barcodes were developed for this experiment: Drawing Barcode (DB), Treatment Barcode (TB), Pre-assembly Barcode (PAB), Site Barcode (SB), and Pallet Barcode (PB). Figure 7-4 illustrates the roles of these five kinds of barcodes and the whole fabrication tracking process map. At the early stage, shop drawings were received and uploaded into the proposed tracking system. Physical barcodes were designed and printed based on information extracted from engineering drawings. Links between barcodes and virtual 3D models should be correctly created including the internal relationships among barcodes. For example, a PB might link to several SBs. Physical barcodes were not attached to real components during the process of cutting, drilling, assembly, and welding. DBs attached the shop drawings were scanned to update the progress because: (1) the process of cutting and drilling was always designed for a batch of components, instead of one single component; (2) there were lots of small bits and pieces after cutting and drilling which was difficult to affix barcodes to; and (3) shop drawings were sent through these processes from one work team to another.

After welding, TBs were attached to the three components individually and scanned before being shipped to the surface treatment yard. When the components arrived, treatment workers needed to scan the TBs, update the status, and remove the TBs so as to conduct treatment work.

After surface treatment, PABs should be affixed to the components. When the PABs were scanned, workers could get detailed pre-assembly information. SBs were affixed after pre-assembly for load out tracking. In this experiment, the two columns and one beam were packaged into one pallet, hence, a PB was needed to put on the pallet. Quality Assurance (QA) and Quality Control (QC) were also embedded into the tracking process and could be automatically triggered through barcode scanning.

All the physical barcodes were attached by the workers involved in each process. Therefore, it was unnecessary to assign a dedicated worker to handle these attaching activities. In addition, the usage of barcodes would not significantly increase workers' workload because they needed to manually mark each steel item by using a chalk in a conventional way.

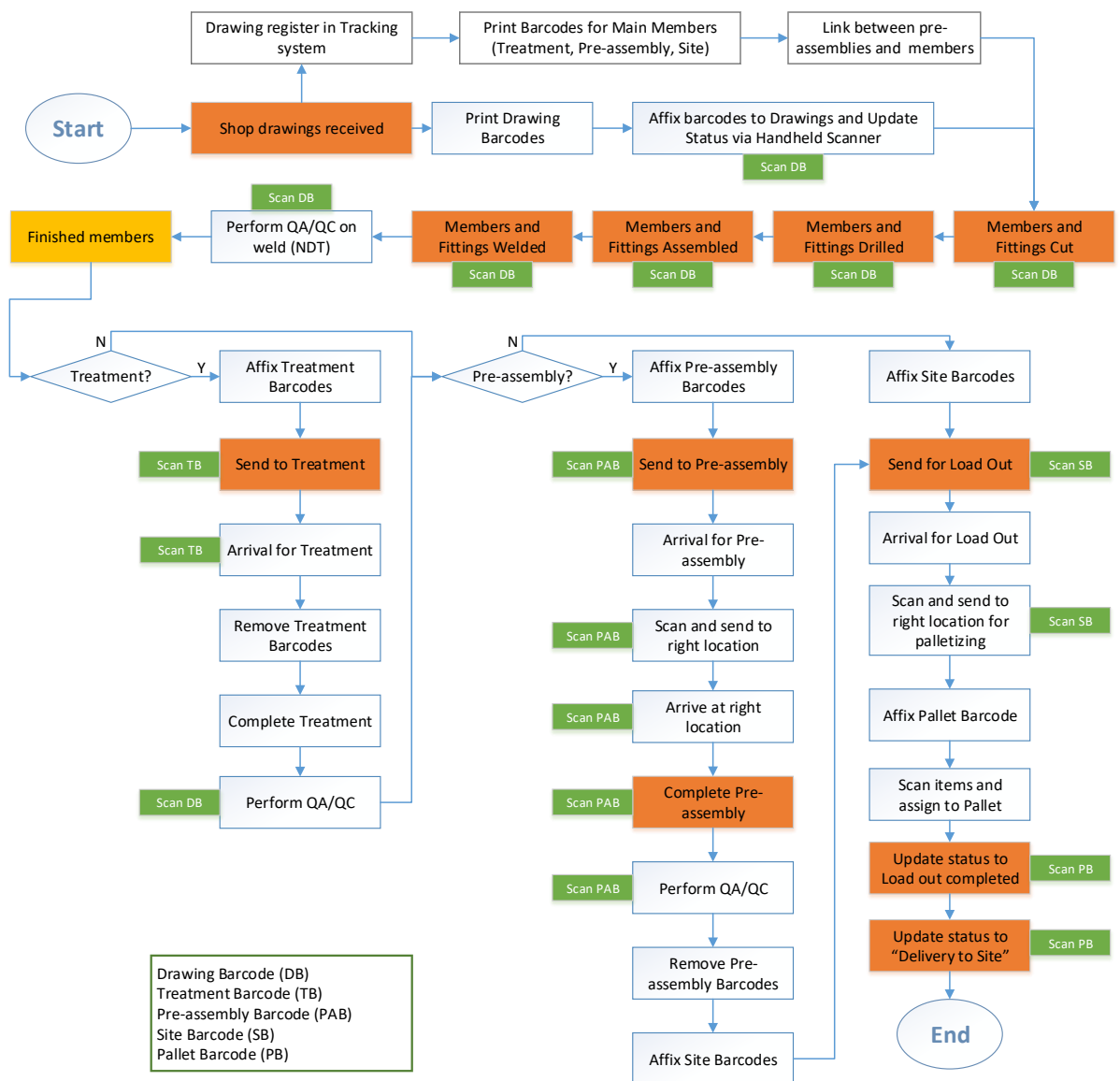

Figure 7-4: Field Implementation Map for Barcoding Technology



### (3) Location tracking

There were two methods for location tracking during fabrication as illustrated in Figure 7-5. The first one was GPS-enabled locating which relied on the GPS data from the mobile reader. If the GPS was unable to work, the second method would be used, i.e. the user could manually choose a predefined location for a component if needed. In this experiment, the first locating method was used during the stages of surface treatment and ready for delivery because both of them were conducted outside. The second locating method was adopted for the remaining processes.

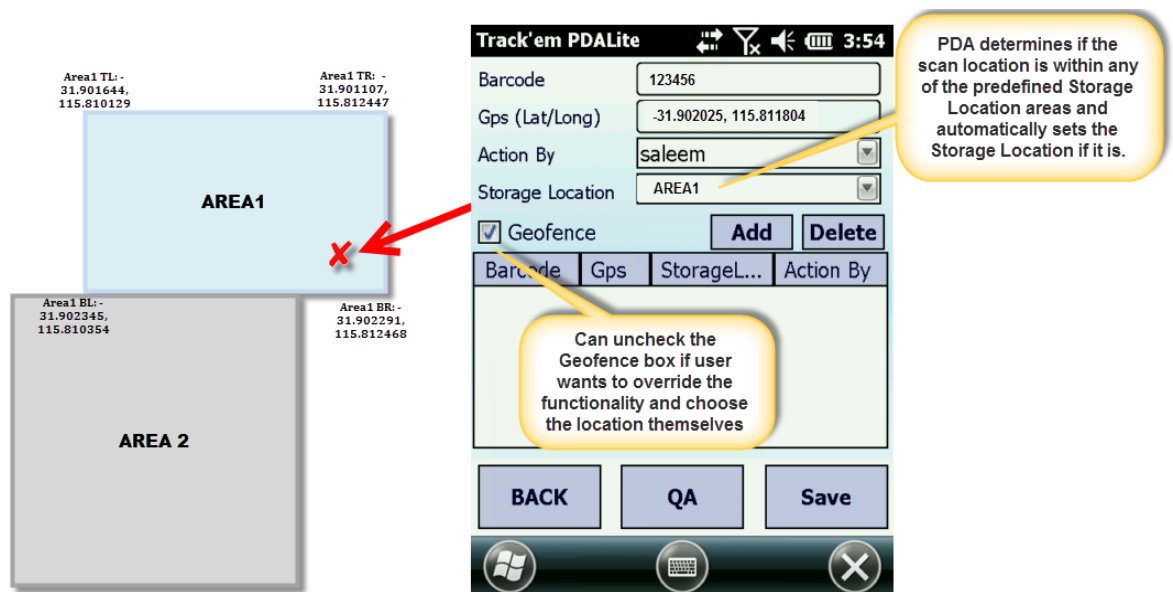

Figure 7-5: Two Locating Methods for Fabrication Tracking

### (4) Results and discussions for experiment one

Two different types of data collected from barcoding were interpreted. Table 7-4 shows the locations of the three components at the end of each day during the experiment. Figure 7-6 illustrates the progress data for each individual component and the overall project. Column 1 and Beam 1 could be located and were produced faster than Column 2, however, both of them needed to wait for Column 2 at the Zone 4 for the pre-assembly. In this experiment, a planned schedule for these three components was not set. However, if the overall progress was behind the schedule, it would be straightforward for the fabrication manager to find the root cause (the delay of Column 2), and quickly remedy the delay (i.e. assign more resource to Column 2 fabrication).

Compared with conventional methods (periodic reports-driven and weekly basis), three benefits of the proposed barcoding system were identified and quantified:

- Cost reduction by avoiding lost/missing piece-marks: According to the historical data of Fremantle Steel Group, 1% of piece-marks were lost/misplaced during the whole fabrication process. For this pilot project, there were nearly 28,000 pieces, which means 280 pieces of them would have been lost without barcoding. Considering each piece would cost \$150 to reconcile/find, a total of \$42,000 would be saved. This did not include the emergency fabrication costs of lost pieces which would cost a minimum of \$1,000 per piece. Considering the technology adoption cost, including: barcode printing cost ( $\$0.01 \times 28,000 = \$280$ ), mobile readers ( $\$200 \times 6 = 1200$ ), software cost ( $\$11.95/\text{month}/\text{user} \times 6 \times 6 = \$430$ ), and training cost ( $\$100/\text{hour} \times 8 = \$800$ ), the total net saving was \$39,290.
- Time and cost savings for checking fabrication progress: A clerk position, who needed to input progress data from weekly field reports into a planning system, could be made redundant. It could save about \$60,000 annually. In order to quantify the time savings, the research team had selected a welding process as an example and calculated the time of generating a progress report, which indicated the number of welds produced per welder by type and x-ray percentage. The time spent compiling this information was reduced from 3 hours to an average of 20 minutes.
- More detailed progress data for decision-making. The frequency of progress tracking with barcoding was nearly real-time, which enabled the shop manager to identify progress delays and bottlenecks faster. Therefore, with the help of the proposed barcoding system, it was easy to answer questions including: which piece-marks needed to be pre-assembled together? Where were the individual piece-marks? Which activity was behind the schedule, and when would the specific materials required to arrive on site?

The experiment has achieved its primary aim of testing the proposed barcoding system for fabrication tracking, and the quantitative and qualitative findings are very promising. Certain limitations need to be considered, which are discussed as follows:

- Barcode scanners needed a direct line of sight to the barcode. Scanners could easily find the right barcodes to be scanned before the pre-assembly stage. However, during the stages of pre-assembly and delivering to site, the efficiency of scanning actions declined because scanners spent most of their time to identify the right barcode. One of the site managers in Fremantle Steel Group suggested that the barcodes could be designed in different colors or sizes so that workers could recognise them quickly and easily.
- Barcodes are more easily damaged because they have to be exposed on the outside of the steel product. If a barcode is ripped or damaged, there is no way to scan and update

the statuses of the product. In order to minimize this complication, the longstanding barcodes such as SBs and PBs are suggested to be printed with a plastic protective layer.

- Barcode management is a challenging process. Five different types of barcodes were developed for this experiment based on the requirement of fabrication tracking. It was effortless to design and print these barcodes with the help of a computer. However, it was difficult to ensure that the activities of attaching and removing barcodes were absolutely correct because of the human errors. In order to eliminate the error-prone tasks, basic training for site workers is necessary. In addition, a guideline for barcode management is also needed. For example, for each type of steel components (i.e. column, beam and pipe spool), the best positions for barcodes attachment should be defined.

Table 7-4: Location Change for the Three Components during Fabrication

	9 Nov	10 Nov	11 Nov	12 Nov	13 Nov	14 Nov	15 Nov	16 Nov
Column 1	Zone 1	Zone 2	Zone 2	Zone 3	Zone 3	Zone 4	Zone 4	Zone 5
Column 2	Zone 1	Zone 1	Zone 2	Zone 2	Zone 3	Zone 3	Zone 4	Zone 5
Beam 1	Zone 1	Zone 2	Zone 3	Zone 3	Zone 4	Zone 4	Zone 4	Zone 5

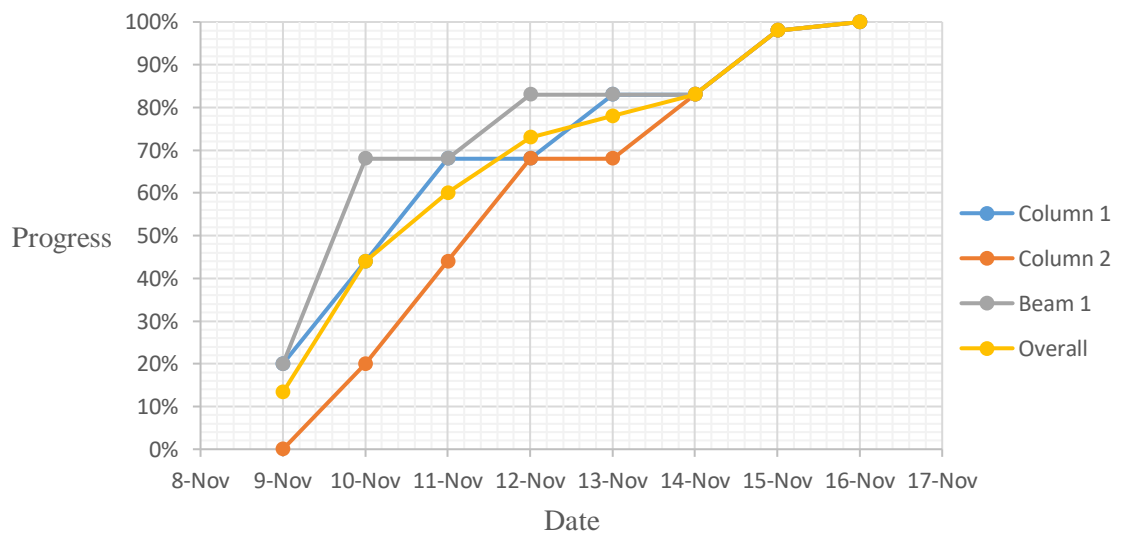

Figure 7-6: Progress for Each Individual Component and the Overall Project

#### **7.4.2 Experiment two: site logistics tracking**

To simulate the delivery of construction materials and related logistics activities, the experiment utilised a real LNG plant training facility as a test bed. The targeted facility was the Australian Centre for Energy and Process Training (ACEPT), run by the Challenger Institute of Technology, located in Perth, Western Australia.

##### **(1) Experiment design**

The simulation scenario can be seen in Figure 7-7. The materials delivery process started from a remote place which could be assumed as a warehouse area. The transportation between the warehouse and the facility was monitored by GPS-based tracking. A GPS tag was mounted on a vehicle and communicated with the satellites frequently. Data about the vehicle's location could be monitored through a web interface, and the progress of delivery could be recorded. Once the materials had been delivered into the simulated construction site, a customized RFID system, running in both active and passive modes, was established and used to monitor the logistics among the laydown yard and construction (or installation) area. The targeted construction area contained a dehydration module which was independent of other process units in the field. In addition, the laydown area had laid some spare module components which could be assumed as delivered construction materials. A simulation of the materials delivery was conducted through the use of the above-mentioned systems, and the entire experiment followed the operation protocol of LNG plant, such as the usage of intrinsically-safe devices, and performing gas leak detection before conducting any experiments.

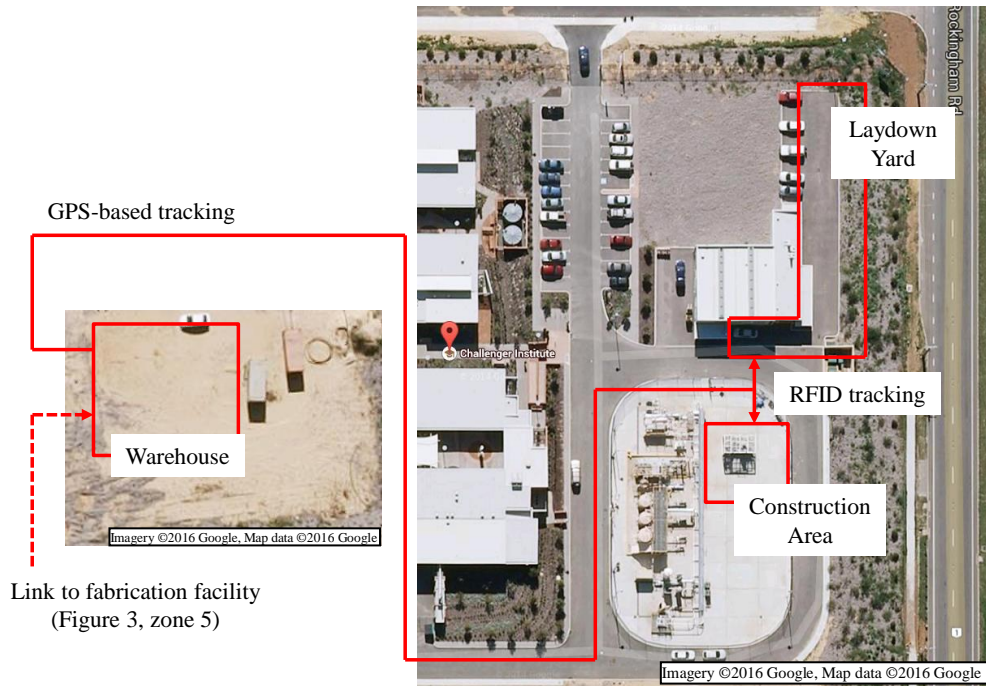

Figure 7-7: The Simulated Scenario of Construction Site Logistics in the Oil and Gas Training Facility

## (2) RFID technology implementation

The experiment particularly focused on the use of the active RFID given that the system was rarely used comparing with that of passive mode and it had the potential in improving the tracking of certain non-line-of-sight activities. The architecture of the active RFID system can be seen in Figure 7-8, and the reader was put in an explosion proof enclosure for fulfilling the intrinsically-safe requirement of the LNG operation field. The antennas mounted on the top of the four-meter-high pole were responsible for receiving Radio Signal Strength (RSS) from each RFID tags for the reader to capture and upload the processed information to servers through WIFI. As for the content of the enclosure, there was a power supply, a reader and a wireless radio. The wireless radio was used as a transmitter for converting the processed information in order to upload through the Internet. Like such settings, there were four different sets have been distributed around the facility. As shown in Figure 7-9, they were located at four corners of the simulated construction area and formed a rectangle (around 30m by 15m) covering the dehydration module. By synchronizing all four received RSS at an acceptable short time period, the locations of tags could thus be identified through triangulation calculations.

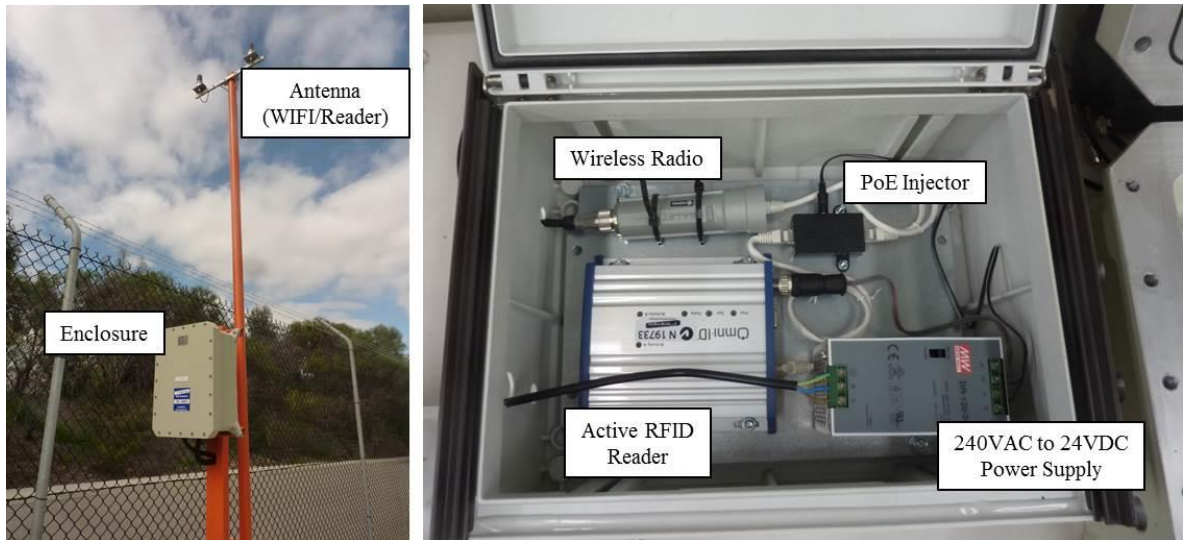

Figure 7-8: The System Architecture of the Installed RFID Reader

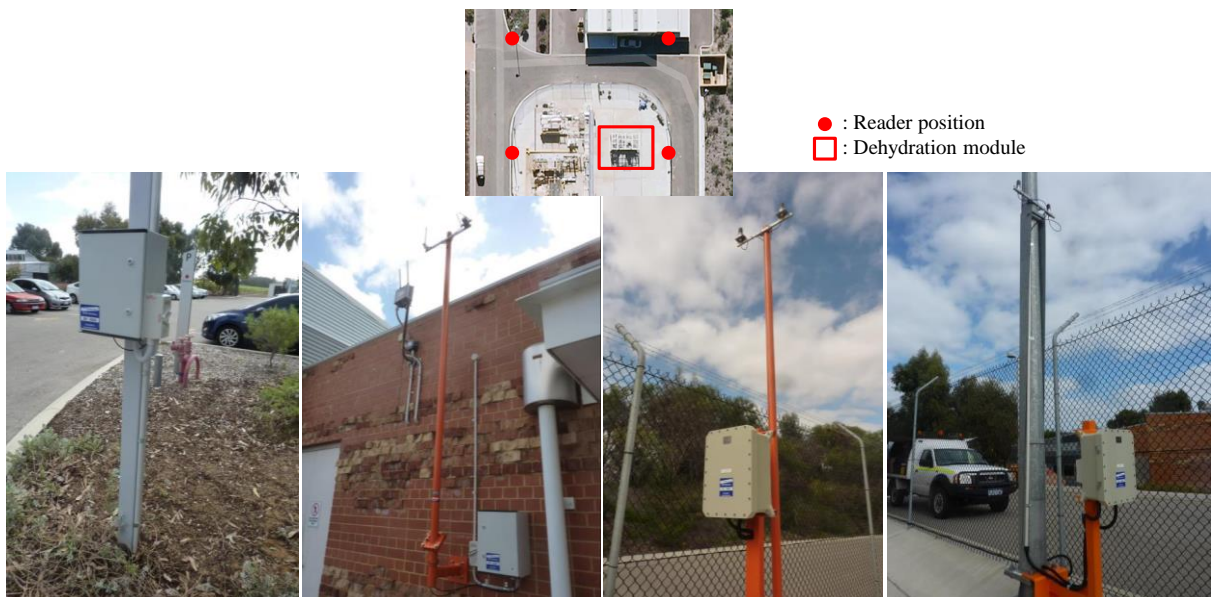

Figure 7-9: Four Fixed RFID Readers around the Dehydration Module

As shown in Figure 7-10, the dehydration module consisted of vessels, pumps, pipes, electronic lines, and other related components and was located in the simulated construction area. Multiple RFID tags were attached to the selected components of the module. The tag could be read through handheld scanners or the four fixed readers, which means that the detection methods could be either active or passive way. The received information could be updated on the materials management system by through the Internet. The dehydration module

and its surrounding regions including the laydown area were used as experiment fields in the simulated construction site. They were used to test the performance of active RFID in static and dynamic situations as well as to conduct a material search test by comparing different combinations of tracking approaches. These tests are described in the following sections in detail.



Figure 7-10: The Attachment of RFID Tags on the Dehydration Module

### (3) Location tracking

To assess the accuracy of the active RFID system, a performance analysis of the RFID tags localization was conducted. In order to understand the status of each attached components in general for site managers and help field workers to search specific ones, accurate location information will be essentially important to shorten the data collection and search time. It could even be extended to monitor the movements of construction equipment or personnel for safety purposes. Given that the magnitude of RSS is related to the distance between reader and tag, the researcher first validated the relationship of RSS between each RFID tags in the simulated LNG plant construction environment. Two randomly selected RFID tags were put at the same position on a trolley located within the detection range of the four fixed readers. Figure 7-11 illustrates the RSS distributions of the two tags. The trolley was still at the beginning. After around 2500 seconds, the trolley started to be pushed and moved around the dehydration module. The results showed that the RSS distributions of the dynamic cases were

more fluctuated than that of the static cases. However, both tags at the same place responded different RSS values but the patterns of changes were similar with each other. It suggests that there was a relationship between RSS responses and the distances of RFID tags, which could be utilised to further improve measurements as long as it could be formed. Once the tags with known locations were obtained as reference tags, the measured location of the target tag could be calibrated by the RSS responses from those tags through the determined relationship.

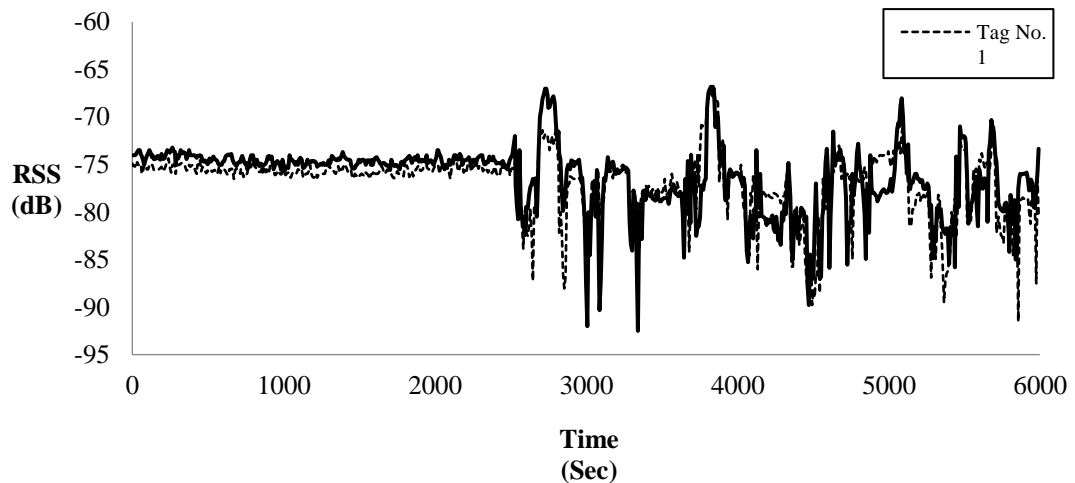

Figure 7-11: The Relationship of RSS Distribution between Two Different RFID Tags at the Same Place

#### (4) Results and discussions for experiment two

A summarised table for all the tests done for site logistic tracking is provided in Table 7-5. The researcher collected the RSS data of each RFID tags on the module. The sampling rate was 3-8 seconds per RSS record. 16 tags with known locations were treated as reference tags for calibration. Similar calibration research had been conducted by Razavi and Haas (2011). Compared to the true positions identified through survey technologies, the positioning errors of static RFID tags through RSS data with reference tags calibration are illustrated in Figure 7-12. Among these 7 tags attached to the module, the errors can be controlled within 3 meters, which suggests that using the active RFID system was capable of tracking non-line-of-sight activities such as knowing where the multiple construction resources were in a relatively large-scale LNG plant construction site. In addition, site managers could easily discover the objects of interest and request field workers to locate it in a short duration. This is because the search range has been narrowed down to a 3-meter radius circle. In cooperation with scanners through the passive RFID technologies, field workers were easily able to identify the necessary targets



instead of following rough directions to search, causing potential waste of time. It also helped conduct deviation analysis at a short duration so that the delay of logistic can be found at the early stage for further decision making.

Table 7-5: An Overview of the Tests Done for Site Logistic Tracking

	Material localization (static case)	Material tracking (dynamic case)	Material search
Technology	Active RFID	Active RFID	Paper instruction, Passive and Active RFID
Subject	7x RFID tags on the module	1x RFID tag on the trolley	50+ plant components in the lay down area
Frequency	3-8 secs/record (sampling rate)	3-8 secs/record (sampling rate)	30 search cases/search methods
Area	Dehydration module	Area around dehydration module	6m x 36m lay down area
Time duration	40 mins	Around 13 mins (800 secs)	Around 1.5hr

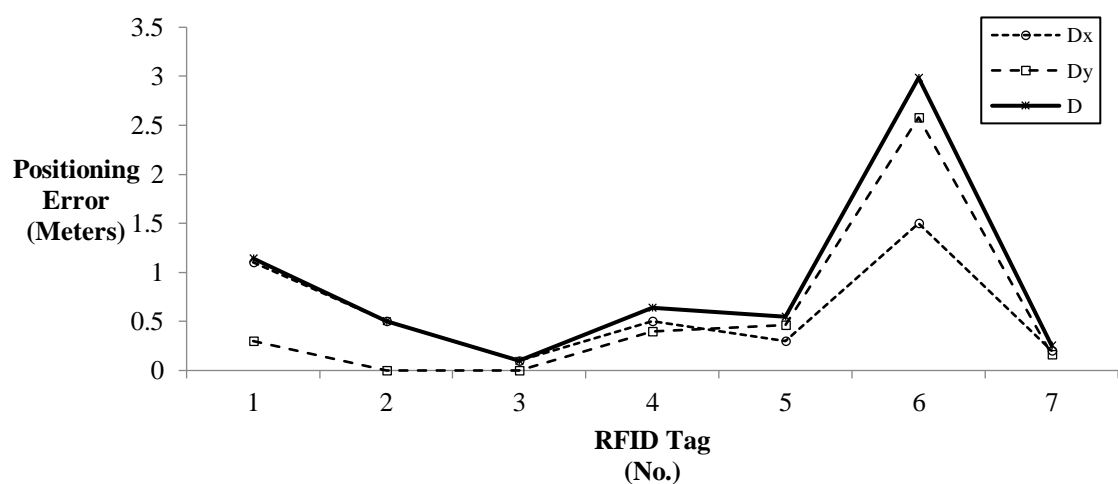

Figure 7-12: Positioning Errors of RFID Tags with Reference Tags Calibration (Static Case)

Regarding the monitoring of dynamic objects on the site, the targeted RFID tag was put on the trolley and moved around the dehydration module. The sampling rate of RSS is the same as the static case and the total recorded time is around 13 minutes. Figure 7-13 shows the tracking errors with time. The range of average errors distribution was from 2 meters to 12 meters and the change pattern of the error was unpredictable. It shows that the RSS of a moving RFID tag was significantly affected by the surrounding environmental factors associated with the time and the location, such as metal, liquid, and other electromagnetic interferences. The results also indicate that improvements on the active RFID system were required for certain tracking tasks, such as equipment movement monitoring or personnel tracking for safety purposes. However, depending on the accuracy requirement, it was still applicable for non-line-of-sight tracking activities which only required rough positions of the target resource, such as work permit monitoring and materials tracking at a large-scale LNG construction site. It is also worthy to note that improving the localization performance of dynamic materials could be a future research direction for optimizing the accuracy of the active RFID with reasonable cost and time.

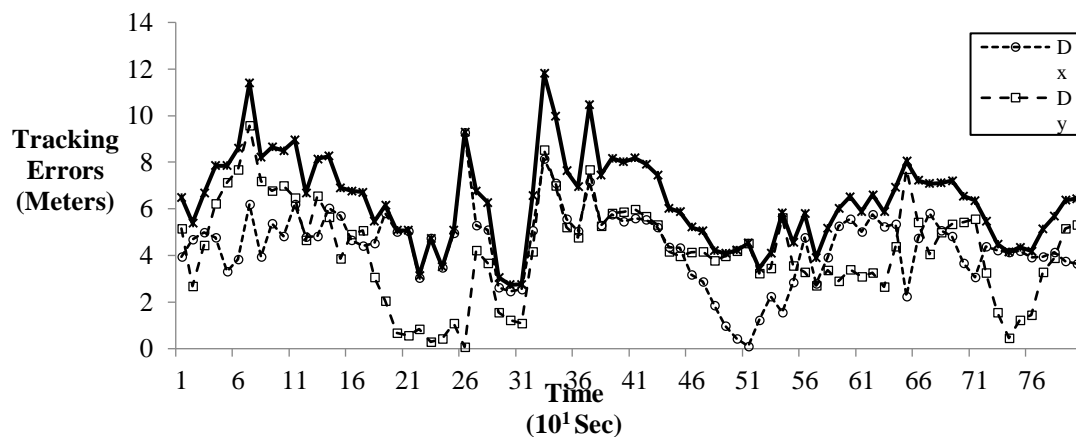

Figure 7-13: Tracking Errors of RFID Tags with Reference Tags Calibration (Dynamic Case)

Compared with conventional approaches in searching necessary materials on site, a RFID system with both active and passive modes had been proved to be feasible, more efficient and effective. The search time distribution of specific material during the material delivery simulation was investigated. Participants were assigned different tasks in allocating specific items in a simulated area (6 x 36 meters laydown area), with more than 50 plant components (valves, pipes, and gauges) on site. The conventional approaches included those of using passive RFID with paper-based instructions and those of using only paper-based instructions. The paper-based instructions represented the rough position estimations made by site

managers according to the existing drawings or layout plans. They were estimated without prior activities of "manually" recording accurate laydown positions when the materials arrived in the area. Based on the feedbacks from field crews and managers, the accuracy of instructions significantly relied on how much experience the site managers had regarding the arrangement of the laydown area.

30 items were identified within the material laydown yard and used as the targets for participants to search by using the three approaches, respectively. Detailed experiment data was collected and analysed. Figure 7-14 shows that the average time spent on searching materials by using both active and passive modes of RFID in the simulated lay down area (Mean: 25.07s, Standard Deviation: 8.238s) was generally faster than those of using passive RFID with paper-based instructions (Mean: 58.83s, Standard Deviation: 19.596s), and those of using only instructions (Mean: 111.47s, Standard Deviation: 36.72s). The average time savings were 33.76s and 86.4s, respectively. It is due to the accurate information that the active RFID could provide for non-light-of-sight tracking activities, like material storage decisions and monitoring, which narrowed the search area down to 3 meters instead of rough search instructions. Using only passive RFID or paper-based instructions might achieve the same efficiency but required extra human and arrangement effort in recording the statuses of materials when materials arrived in positions, while active RFID could acquire such information timely and automatically. It further reduced the preparation time of search tasks and helped improve management from the global perspectives.

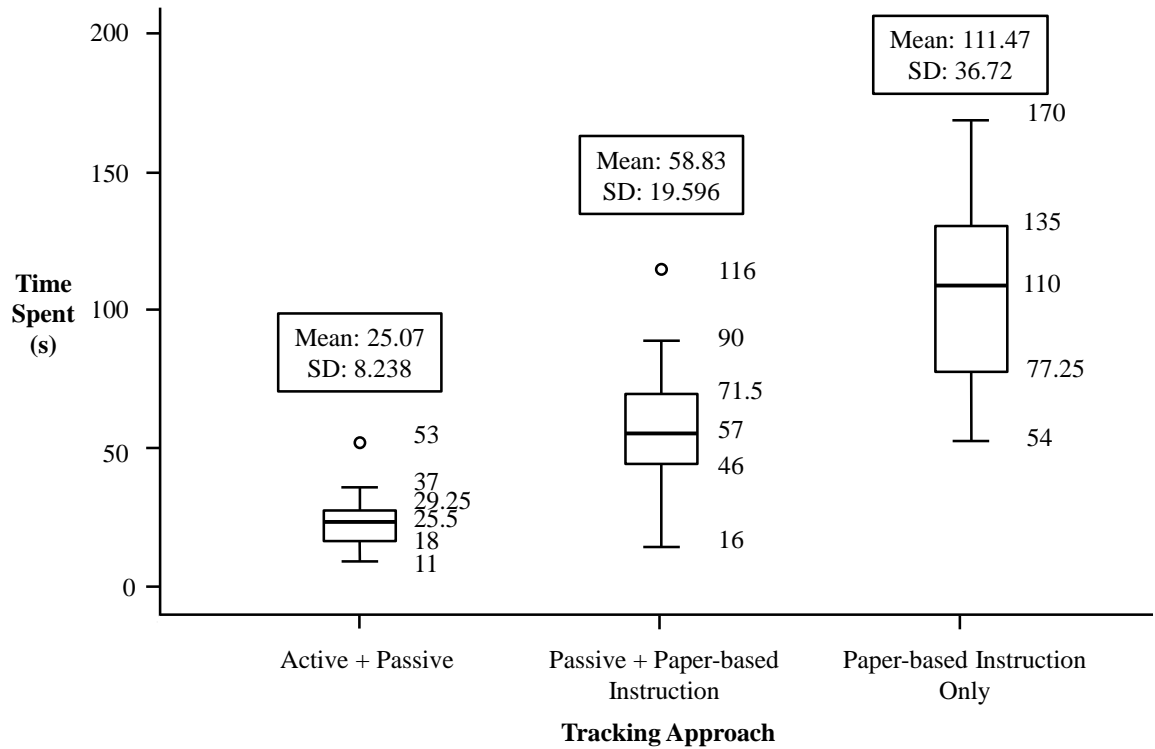

Figure 7-14: Time Spent on Searching Materials in the Simulated Laydown Area

By identifying the accuracy concerns of the active RFID system and going through the materials delivery simulation by using the proposed tracking approach at simulated LNG construction site, the following findings were identified and discussed as below:

- GPS and passive RFID system are conventional yet reliable approaches for tracking long-range transportation and assisting field personnel in searching and identifying objects of interest during the entire site logistics processes. The experiment shows promising results in tracing the goods flow and speeding up the materials search times. However, the performance of the tracking may vary depending on the capabilities of onsite employees and their familiarity of the technologies adopted.
- Active RFID system is able to be implemented as an efficient tracking approach for certain non-line-of-sight activities at the site, such as having the global view of whether the demanded certain resources or personnel are in position at the correct place and correct time. Considering the scale of the LNG plant construction, the error tolerance in acquiring such positioning information is acceptable for the discontinuous positions checking and management purposes. The positioning accuracy can even be improved by the reference tag approach and controlled within three meters. However, for the detailed movements monitoring of resources and helping search the demanded

resource at the site, the tracking approaches still need further investigations, especially on improving tracking results of the dynamic objects within reasonable ranges.

- These results conducted in the material search test may present a certain degree of bias attributed to a number of reasons. Firstly, the scale of the laydown area in practice is much higher than the tested one, which could amplify the uncertainties of searching target items. Secondly, there were biases among participants' skills in searching materials. Although participants were randomly selected, there was a chance of uneven prior knowledge or learning ability. Finally, the accuracy of the paper-based instructions also had a significant impact on the material search. Poor-quality instructions would result in a longer time. However, the results are still helpful to validate the benefits of the proposed approach. The generalization of the test results is acceptable given that the simulated site is exactly "a real process plant" following all the operation and intrinsically-safe regulations for training purposes. The arrangements and layouts of all components followed the designs in practice.
- The integration of the proposed tracking approaches is feasible to establish a total site logistics management mechanism of a technical perspective. However, supply-chain experts also raised concerns as to whether the integrated approach could be adopted due to various factors, such as cost-effectiveness and complicated working processes. Essentially, the LNG industry needs to be closely engaged in order to provide an appropriate platform for the adoption.

## **7.5 Conclusions**

This chapter presents a coordinated approach for total supply-chain constraint tracking in LNG construction. The feasibility of the proposed approach for the project-specific material tracking is validated by the two field experiments. Although not all alternative tracking solutions within the framework are tested, this research has indeed validated the usage of barcode for fabrication tracking. Besides, the capabilities of GPS and active RFID are also tested and validated in tracking non-line-of-sight tracking tasks at a simulated LNG plant construction site. Both GPS and active RFID can cooperate with passive RFID, and allow site managers to get a global view of the materials flow and identify relatively close search range for field workers to locate the materials of interest efficiently.

To sum up the outcomes of this chapter, the benefits identified from the two field experiments are listed as follows:

- The proposed coordinated approach has been validated as a feasible solution for tracking various supply-chain constraints in LNG modular construction. It helps increase the visibility of the total supply chain for complicated and large-scale projects.
- The two field experiments have demonstrated the feasibility of the combination of the barcode, RFID and GPS for the total supply chain constraint tracking in the LNG industry. Despite of the increase of the cost in order to purchase and install the tracking infrastructure, its impact on the overall cost is minimal but can bring significant benefits in terms of time reduction and productivity improvement.
- The experiment conducted in the off-site factory suggests several tangible benefits: \$42,000 will be saved for lost/missing piece-mark reconciliation in the pilot project; \$60,000 will be saved annually due to the reduction of a clerk position; and time spent in welding progress tracking can be reduced from 3 hours to an average of 20 minutes.
- Based on the observations of site logistic experiment, the search range of material has been narrowed down through active RFID used in cooperation with scanners through passive RFID. Compared with conventional approaches in material searching, the proposed tracking solution is two times faster than those of using passive RFID with paper-based instructions, and four times faster than those of using instructions only.

Although the improvement is identified, further validations should be conducted which include: (1) validating the feasibility of the proposed framework for the general material tracking in an LNG construction project; (2) evaluating the capabilities of other suggested tracking solutions, such as the utilisation of passive RFID with a handheld reader for fabrication tracking. Compared with the barcode technology, passive RFID has all the advantages except its higher implementation cost. The first two limitations of barcode found in this research can be easily addressed by using passive RFID; (3) applying the proposed framework in a real LNG construction project and measure its performance; and (4) extending the application of the proposed framework to other industries, such as mining, infrastructure, and building.

## Chapter 8: TCM Method for Improving Construction Work Flow and Productivity

### 8.1 Introduction

Chapter 8 proposes a TCM method developed based on the research outcomes from Chapter 4-7 (i.e. *Research Objective 5*). Other information technologies (i.e. BIM, Laser scanning and Photogrammetry) were also discussed and incorporated into the TCM method so as to make it more practical and effective. A laboratory experiment (i.e. *Laboratory Experiment 2* explained in Section 3.2.2, Chapter 3) was developed to validate the effectiveness and efficiency of the proposed TCM method. The results show that successful implementation of TCM can significantly improve construction workflow and productivity.

### 8.2 Overall Design of the TCM Method

This section describes an overall design of the TCM method (as shown in Figure 8-1) which aims to improve work flow and productivity in LNG construction. The proposed TCM method includes four main modules:

- **Module 1** (i.e. Research outcome of Chapter 4): A hierarchical constraint management process module (highlighted in light yellow colour);
- **Module 2** (i.e. Research outcome of Chapter 5): A DNA-based constraint modelling and analysis module (highlighted in light blue colour);
- **Module 3** (i.e. Research outcome of Chapter 6): A linked data-enabled cross-domain constraint information sharing module (highlighted in light green colour); and
- **Module 4** (i.e. Research outcome of Chapter 7): A sensor-based constraint monitoring module (highlighted in light red colour).

Module 1 defines when to start the constraint management process, and how to efficiently identify project constraints; Module 2 defines how to dynamically model and analyse these constraints identified in Module 1; and Module 4 defines how to use emerging sensor technologies to automatically monitor constraint status. All the data and information generated from Module 1, 2, and 4 are collected and stored in Module 3 (i.e. a linked data-enabled cross-domain constraint information management and sharing platform). Due to the advantages of the Linked Data technology, project participants can efficiently access all the constraint information (e.g. constraint type, links to other constraints, constraint priority, constraint maturity, constraint status, constraint delay impact, etc.) even they are stored in multiple isolated databases.

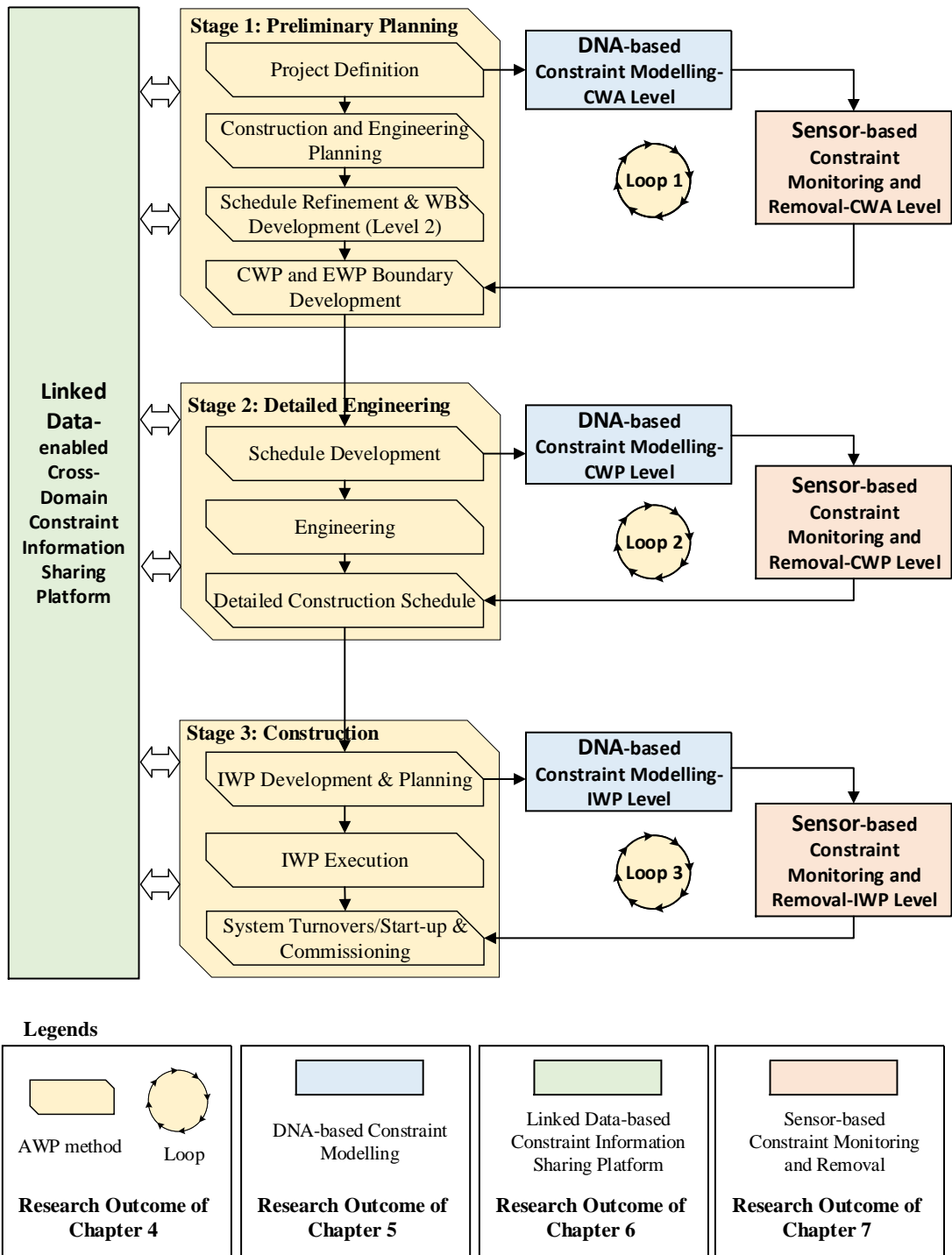

Figure 8-1: Overall Design of the TCM Method

### 8.3 Validation of the TCM Method

A laboratory experiment (i.e. *Laboratory Experiment 2* explained in Section 3.2.2, Chapter 3) was developed to validate the effectiveness and efficiency of the proposed TCM method. A total of 83 EWPs, 10 CWPs and 172 IWPs were developed for the LNG Construction Simulation Game. In order to simulate engineering works, all the drawings and specifications



were taken into predefined engineering offices respectively according to different disciplines, such as mechanical, electrical, civil and piping. The released time for these drawings and specifications to the construction site was planned based on the design of the experiment. Twelve long-lead constraints designed by the author were incorporated into the game. Examples of long-lead items in this experiment were equipment (i.e. Compressor, Convert, Pressure, Battery and Power) that was designed and built specifically for the project, and tools (i.e. Allen keys) and materials (Circuit board, Bar, Connector, Metal pin, Long pipe, and Switch) that were purchased in other countries. If the project team could not identify these constraints as early as possible, the game would suffer delay.

In the first round of play to simulate the TCM method, the project manager of Group A was provided with a construction plan and a constraint meta-network (as shown in Figure 8-2). He can efficiently check constraint information through sample clicks. For example, when clicking “IWP 6.2”, the project manager could find all related constraints and their planned removal time. With TCM implementation, Group A found all the long-lead constraints in the first ten minutes through DNA method, and developed proper action strategies to assure them could be timely removed. After the first five minutes, the first client representative began to select design variations at random for LNG modules and civil foundations in random sequence. Figure 8-3 showed an example of design variations in civil foundations. Two typical variations (B and C) were developed to the standard default design (A). Each design changes needed to be addressed even the modules were delivered to the site or finished the installation. Moreover, only the appropriate subcontractors could make the changes called for in the variation change order. In order to reduce rework, Group A changed the work sequence to follow the random sequence in which design variations were selected. Work was started on an LNG module only after its design variation had been selected.

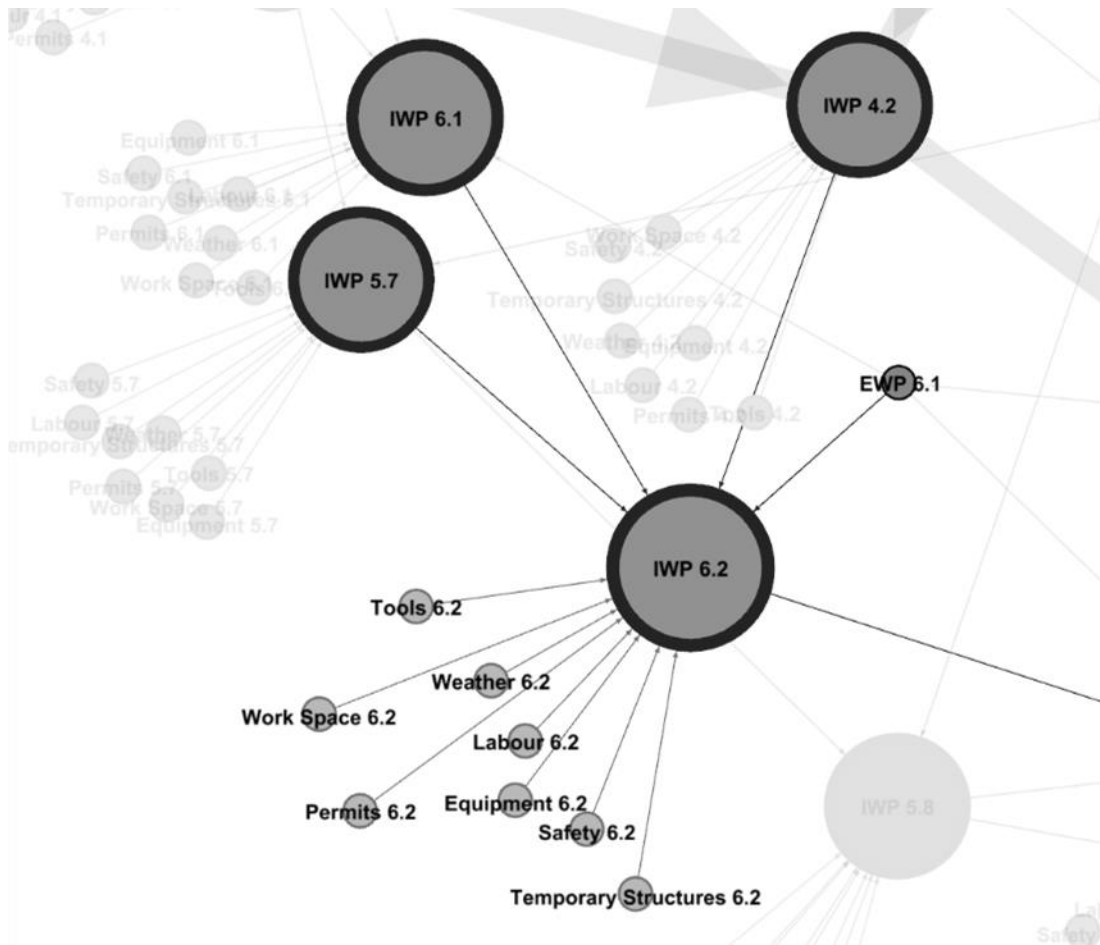
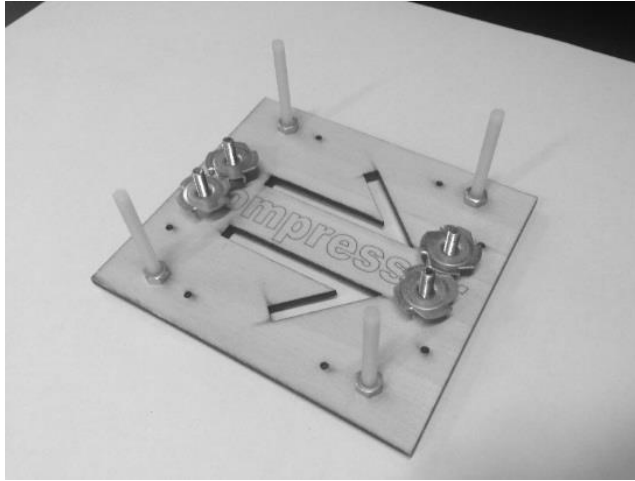
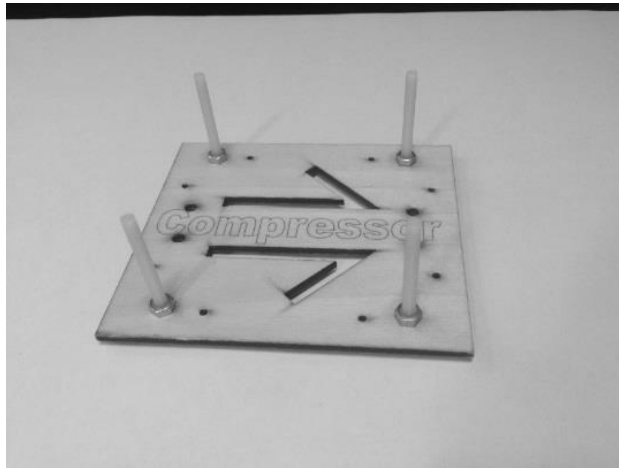

Figure 8-2: Constraint Meta-network

Regarding constraint monitoring, it was not feasible to implement the proposed sensor-based tracking solutions (i.e. RFID, GPS, and Barcode) in this simulation game. However, in order to simulate the real-time constraint tracking and status updating, the project manager was allowed to walk around to get all the latest status of the constraints. The second client representative inspected each completed IWP and recorded the time. The play was finished after 31 minutes, and the performance of Group A was assessed in terms of progress, defective LNG modules, productivity, and duration.



(a) Standard default design



(b) Design variation-1

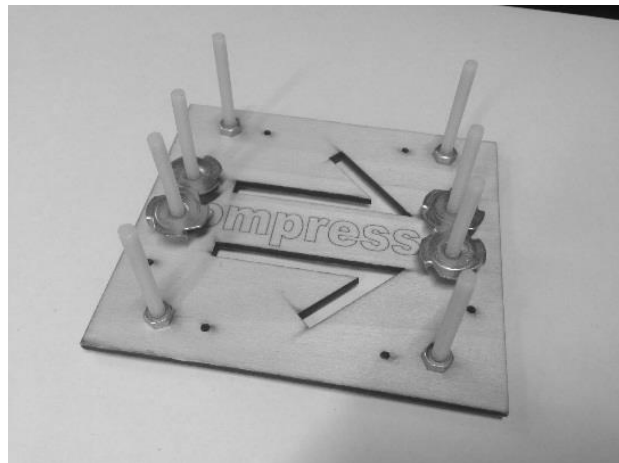

(c) Design variation-2

Figure 8-3: An Example of Design Variations in Civil Foundations

In the second round to simulate the conventional constraint removal approach, the following changes were made, while all other conditions remained as before:

- (1) Constraint analysis was late implemented and only happened at the IWP development stage. Currently, in most cases, constraint analysis started at the look-ahead planning phase, and was done by examining each activity that was scheduled to perform within the next six to eight weeks. In this regards, it was reasonable to assume the action of constraint analysis only happened at the IWP level, not CWP or higher level.
- (2) Project manager of Group B was not allowed to walk around, and could only perform constraint removal in his own office based on progress reports and commitments. Most companies traditionally performed constraint removal based on their regular coordination meetings. Constraint status was manually updated according to paper-based reports and oral commitments. In this experiment, all the contractors and subcontractors were worked within a small area. The action of “walk around” could make the project manager got nearly real-time constraint information including status. Therefore, in order to largely reflect the real world experience, this assumption was formulated.
- (3) Constraint relationship map and removal plan were not provided to Group B. In the conventional approach, constraint analysis and removal were conducted informally, thus the experience, foresight, and general capabilities of the managers made a great deal of difference. According to the feedbacks of the thirteen industry experts, very few projects developed constraint relationship map and removal plan. The most common practice was identifying and listing all the constraints for each activity from a local perspective, not the globe.

Without TCM implementation, all the twelve long-lead constraints were not timely found until the third ten minutes. Delays were suffered at the end of the first ten minutes because of materials and tools shortage. The performance of group B was also measured by the second client representative.

#### **8.4 Results and discussions**

After the two rounds of simulation, the performance data of the two groups were calculated. The parameters of interest were the number of defective LNG modules, the actual duration, the actual progress for each time interval and the productivity for each trade. The first two were easily measured; the latter two were calculated according to the following two rules, respectively:

- (1) Index of Cumulative Progress (CP) was developed to measure the actual progress at the end of each time interval. In this study, the time interval was set to 10 minutes. The formula was:  $CP = A_1 * A_{1w} + A_2 * A_{2w} + A_3 * A_{3w} + \dots + A_n * A_{nw}$ . The value of  $A_n$  was the actual progress of construction trade n, which could be measured based on the finished quantity divided by the total quantity.  $A_{nw}$  was the weight of the trade n for CP calculation. The specified values of  $A_{nw}$  were listed in Table 8-1.
- (2) The productivity index was calculated based on each construction trade. The formula was:  $P_n = Q_n / (T_f - T_s)$ .  $P_n$ : productivity of trade n;  $Q_n$ : total quantity of trade n;  $T_f$ : finish time of trade n; and  $T_s$ : start time of trade n.

Table 8-1: The Weight of Each Trade for CP Calculation

Construction trades (n)	Descriptions	Weight (%) ( $A_{nw}$ )
1	Site preparation	30 ( $A_{1w}$ )
2	Off-site module manufacturing	10 ( $A_{2w}$ )
3	Module installation	15 ( $A_{3w}$ )
4	Pipework installation	28 ( $A_{4w}$ )
5	Wiring installation	10 ( $A_{5w}$ )
6	Major equipment installation	5 ( $A_{6w}$ )
7	Commissioning	2 ( $A_{7w}$ )

Table 8-2 showed the actual duration and CP values of the two groups. Group B took 43 minutes to finish the whole construction works while Group A took 31 minutes, which meant 28% of the project duration was reduced. At the end of the second ten minutes, the CP of Group A was 63%, however, the value for Group B was only 47%. The main underlying reason was related to the long-lead constraints. Group B spent more time to wait for the constraints to be removed because of the late implementation of the constraint analysis.

Table 8-3 illustrated the number of the defective modules and productivity index of the two groups. The measurement of the defective module was based on a comparison between as-built and as-designed modules. If the difference(s) were found in a module which would be treated as a defective module. Figure 8-4(c) showed a defective module built by Group B which in line with the original design (as shown in Figure 8-4(a)), not the latest design (as shown in Figure 8-4(b)). The correct module was showed in Figure 8-4(d). The defective

modules were significantly reduced in Group A when compared with Group B. The reason was that Group A could effectively reduce the impact of the design changes with TCM implementation. The values of productivity index of Group A were higher than Group B except commissioning. Because the commissioning was the last work of the simulation game, and the value of the productivity was only dependent on the operation proficiency. Productivity was dramatically improved in the works of off-site module manufacturing, module installation, and major equipment installation because the work flow in Group A was more stable than Group B.

Table 8-2: Actual Duration and CP of the Two Groups

Groups	Actual duration (minutes)	CP at the end of the first ten minutes (%)	CP at the end of the second ten minutes (%)	CP at the end of the third ten minutes (%)	CP at the end of the fourth ten minutes (%)	CP at the end of the fifth ten minutes (%)
Group A	31	21	63	95	100	-
Group B	43	16	47	71	92	100

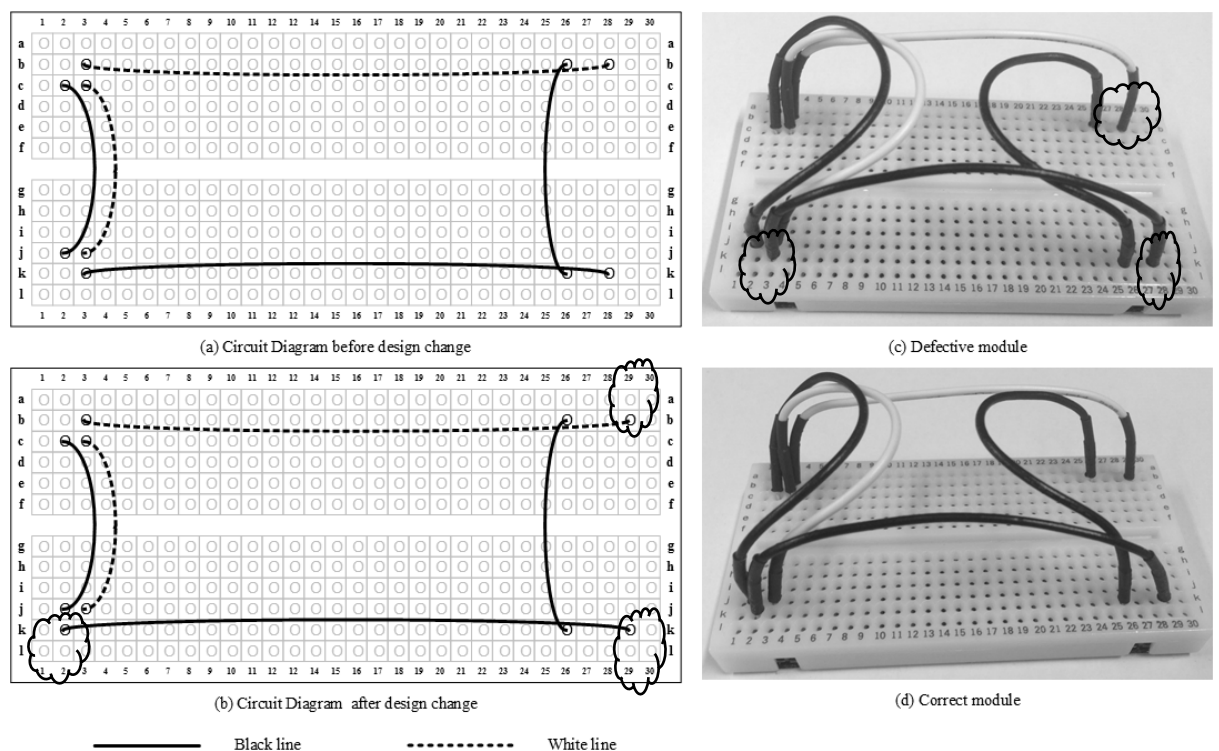

Figure 8-4: An Example of Defective Module

Table 8-3: The Number of the Defective Modules and Productivity Index of the Two Groups

Construction trades	Defective modules		Productivity (unit/min)	
	Group A	Group B	Group A	Group B
Site preparation	0	1	1.315	1.214
Off-site module manufacturing	0	5	1.307	0.662
Module installation	0	3	4.348	1.887
Pipework installation	0	0	1.603	1.216
Wiring installation	0	0	2.384	2.096
Major equipment installation	0	1	0.352	0.263
Commissioning	0	0	15.625	15.214

These results may present some normal degree of error and bias attributable to a number of reasons (González et al. 2015). Firstly, the nature of the simulation game revolves around human participation, some error may occur when measuring the performance metrics during each round. Various playing attitudes (i.e. positive and negative) or motivations can interfere with the accuracy of results. Secondly, there are biases between the two groups. Although participants were randomly allocated to groups, there is a chance of uneven prior knowledge or learning ability. Enhanced prior knowledge would cause the simulation game to be easier for those people than completely new players. Finally, it is likely there is a learning curve effect for the two groups, which could impact the observed improvement. In general, the author argue that some errors and biases may be present; however, the results still can validate the benefits of TCM implementation in LNG construction.

## 8.5 Conclusions

Results from the simulation game indicate a positive effect of facilitations when implementing the proposed TCM method in LNG construction. 28% of project duration was reduced while no defective modules were found during TCM implementation. Productivity was also improved, especially in the works of off-site module manufacturing and module installation which increased by around two times.

The size of the lean game is relatively small, and the duration is only within one hour. Although the observed improvement is clear, further validation should be conducted to drawing more definitive conclusions as to this scale of improvement. Potential research includes engaging LNG industry experts to play the lean game and measuring their performance, and conducting several Field Tests to evaluate the improvement of TCM implementation.



## **Chapter 9: Conclusions, Implications, and Future Recommendations**

Summaries presented at the end of previous chapters have already given a detailed account of the works and main findings of this research. This chapter closes this thesis by presenting those main conclusions relating to the research objectives defined at Chapter 1. It also summarises theoretical contributions and practical implications of this research. Recommendations for future research are presented at the end of this Chapter.

### **9.1 Conclusions**

The aim of this section is to summarise the research findings in order to (1) draw unambiguous conclusions from the results; and (2) provide empirical evidence to demonstrate the capabilities of the developed methods.

This research aims to develop and validate a TCM method for improving plan reliability and work productivity in LNG construction. A positivist epistemology was adopted as the main research methodology. Mixed methods of both qualitative and quantitative methods were conducted subsequently, for instance, focus group study method was conducted to facilitate the development of the TCM framework while experimental methods including lab-based experiments (i.e. Lean Simulation Game) and field experiments were conducted to validate the effectiveness and efficiency of the proposed TCM framework.

The review of existing constraint theories, and constraint management practices in Chapter 2 has clearly shown that there are significant research gaps in constraint modelling, constraint information sharing, and constraint monitoring. The structure of constraints in LNG construction is a dynamic network with multi-levels, multi-nodes, and multi-links. When modelling and analysing such types of constraints, existing approaches (i.e. mathematical model-based, simulation-based, visualisation-based, or pull-driven approaches) have either a very limited constraint coverage or a weak capability in constraint analysis. In addition, information of these constraints including their statuses are stored in different ways (i.e. different data schemas), at various locations and managed by multiple vendors from different domains (i.e. different vocabularies). Therefore, it is difficult for project participants to efficiently access these sources of information by using existing approaches such as (1) Meeting- and paper-based approaches; (2) Internet/Web-based approaches; or (3) BIM-based approaches.

In order to fill these gaps, this thesis developed a TCM method which includes four main modules: A hierarchical constraint management process module (Module 1); A DNA-based constraint modelling and analysis module (Module 2); A linked data-enabled cross-domain

constraint information sharing module (Module 3); and A sensor-based constraint monitoring module (Module 4). Module 1 defines when to start the constraint management process, and how to efficiently identify project constraints; Module 2 defines how to dynamically model and analyse these constraints identified in Module 1; and Module 4 defines how to use emerging sensor technologies to automatically monitor constraint status. All the data and information generated from Module 1, 2, and 4 are collected and stored in Module 3. The evaluation revealed that the proposed TCM method could significantly improve plan reliability and work productivity. The following sub-sections provide detailed conclusions for each of the five main research objectives posed in Chapter 1. These findings have clearly proven the achievement of the research aim, and explicitly confirmed the overarching research proposition: “*The proposed TCM method can perform better in constraint identification, modelling, monitoring, and removal, and thus, can significantly improve construction productivity*”.

### 9.1.1 Research findings for Objective 1

<p><b><i>Objective 1</i></b></p> <p>To develop a hierarchical constraint management process to identify and remove constraints through project life cycles.</p>
<p><b><i>Summarised Research Findings</i></b></p> <ul style="list-style-type: none"> <li>❖ A hierarchical constraint management process was developed through literature review and <i>Focus Group Study 1</i>.</li> <li>❖ The proposed process consists of three levels of loops: <ul style="list-style-type: none"> <li>• Loop 1 at CWA level which aims to identify and monitor constraints that has a long lead time and align engineering and procurement plans to the construction plan;</li> <li>• Loop 2 at CWP level which aims to manage constraints from a construction-centred perspective, and continually involve owner, engineers, purchasers and contractors to find new constraints and detect potential constraint-removal issues; and</li> <li>• Loop 3 at IWP which aims to maintain, monitor and remove constraints from an installation-centred perspective.</li> </ul> </li> </ul>

## 9.1.2 Research findings for Objective 2

### ***Objective 2***

To develop a network-based constraint modelling method for describing the interdependencies among constraints.

### ***Summarised Research Findings***

- ❖ A DNA-enabled constraint modelling method was developed to understand the complex interactions in a constraint network.
- ❖ The proposed method was tested based on a laboratory-based experiment. Five measures were developed to analyse the constraint meta-network evolution, including:  $NUC_i$ ,  $VCR_i$ ,  $VIRS_i$ ,  $ODCN$ ,  $IDCN$ , and  $IDIN$  (Detailed explanation of these measures can be found in Table 5-3, Section 5.3.3). An IWP-oriented constraint meta-network was developed which contained 1766 nodes and 2589 links (1947 constraint links, 297 sequence links, and 345 superintendent links). The network diameter was thirty-four, and the average path length was about eleven. Detailed experiment results are summarised as follows:
  - *Five out of five conflicts (100% accuracy)* were successfully detected between construction plan and engineering constraint-removal plan ( $NUC_{total} = \sum_0^{28} NUC_i = 5$ ,  $NUC_i$  is calculated based on the Engineering Constraint Network);
  - *Twelve out of twelve conflicts (100% accuracy)* were successfully detected between construction plan and supply-chain constraint-removal plan ( $NUC_{total} = \sum_0^{28} NUC_i = 12$ ,  $NUC_i$  is calculated based on the Supply-Chain Constraint Network);
  - *Twenty-three out of twenty-three conflicts (100% accuracy)* were successfully detected between construction plan and site constraint-removal plan ( $NUC_{total} = \sum_0^{28} NUC_i = 23$ ,  $NUC_i$  is calculated based on the Site Constraint Network);
  - *Four engineering constraints* were recognised as critical constraints (i.e. four engineering constraint nodes have the maximal value of the  $ODCN$ :  $ODCN_{max}=6$ );
  - *Thirty supply chain constraints* were detected as critical constraints (i.e. thirty supply chain constraint nodes have the maximal value of the  $ODCN$ :  $ODCN_{max}=6$ );
  - *Eighteen IWPs* were identified as critical work packages (i.e. eighteen IWP nodes have the maximal value of the  $IDCN$ :  $IDCN_{max}=19$ ).

### ***Limitations***

- ❖ The constraint meta-network is manually created which is time-consuming and labour-intensive;
- ❖ The five measures developed for analysing the constraint meta-network evolution are simplified and do not include the weight and probability of the links.

### 9.1.3 Research findings for Objective 3

#### ***Objective 3***

To develop a data management platform for cross-domain constraint information sharing.

#### ***Summarised Research Findings***

- ❖ A linked data-enabled platform was developed for improving cross-domain constraint information sharing, which includes:
  - Two newly developed ontologies, i.e. constraint ontology, and AWP ontology;
  - Three RDF data transformation methods: Drawing data to RDF, Table data to RDF, and Document meta-data to RDF;
  - Two data interconnection methods: data interconnection among RDF data sets, and data interconnection between RDF triples and documents.
- ❖ A pilot case study was conducted to demonstrate the capabilities of the proposed approach. Detailed results are listed as follows:
  - Cross-domain constraint information searching can be successfully executed through SPARQL Query with or without inference rules;
  - The SPARQL Query results can be precisely visualised in tabular and/or graph formats;
  - External reference data libraries and document systems can be linked and queried;
  - The accuracy of the executed SPARQL Queries is 100%.

#### **Limitations**

- ❖ The size of the RDF dataset is relatively small (there are only 103766 RDF triples included);
- ❖ The complexity of the selected LNG module is relatively low because only dehydration systems are included;
- ❖ The prototype is not mature enough and require users to be familiar with the SPARQL language in order to use the prototype efficiently.

#### 9.1.4 Research findings for Objective 4

<p><b>Objective 4</b></p> <p>To investigate current tracking technologies for real-time constraint tracking.</p>
<p><b>Summarised Research Findings</b></p> <ul style="list-style-type: none"><li>❖ A framework of a coordinated approach for supply-chain constraint tracking was developed.</li><li>❖ A prototype was developed for sensor data (i.e. barcode, RFID, and GPS) reading, configuration, mapping, and synchronization.</li><li>❖ The experiment conducted in the off-site factory suggests that:<ul style="list-style-type: none"><li>• \$42,000 could be saved for lost/missing piece-mark reconciliation in the pilot project;</li><li>• \$60,000 could be saved annually due to the reduction of a clerk position; and</li><li>• Time spent in welding progress tracking was reduced from 3 hours to an average of 20 minutes.</li></ul></li><li>❖ The experiment conducted in the construction site suggests that:<ul style="list-style-type: none"><li>• The search range of material has been <i>significantly narrowed down</i> through active RFID used in cooperation with scanners through passive RFID;</li><li>• Compared with conventional approaches in material searching, the proposed tracking solution is <i>two times faster</i> than those of using passive RFID with paper-based instructions, and <i>four times faster</i> than those of using instructions only.</li></ul></li></ul>
<p><b>Limitations</b></p> <ul style="list-style-type: none"><li>❖ The two experiments are all conducted in a controlled environment which may not represent a fully realistic situation;</li></ul>

#### 9.1.5 Research findings for Objective 5

<p><b>Objective 5</b></p> <p>To develop a TCM method based on the research outcomes from Objective 1-4</p>
<p><b>Summarised Research Findings</b></p> <ul style="list-style-type: none"><li>❖ A TCM method was developed which includes the following four main inter-connected modules:<ul style="list-style-type: none"><li>• <b>Module 1</b> (i.e. Research outcome of Objective 1): A hierarchical constraint management process module (highlighted in light yellow colour);</li></ul></li></ul>

- **Module 2** (i.e. Research outcome of Objective 2): A DNA-based constraint modelling and analysis module (highlighted in light blue colour);
  - **Module 3** (i.e. Research outcome of Objective 3): A linked data-enabled cross-domain constraint information sharing module (highlighted in light green colour); and
  - **Module 4** (i.e. Research outcome of Objective 4): A sensor-based constraint monitoring module (highlighted in light red colour).
- ❖ The TCM method was tested in an LNG construction simulation game (i.e. *Laboratory Experiment 2*), significant improvement had been achieved when compared with the conventional approach:
- All of the *twelve long-lead constraints* were successfully identified in the *first ten minutes*, and detailed constraint-removal strategies were also developed. When using conventional approach, the twelve long-lead constraints were *not timely identified until the third ten minutes*. Delays happened at the end of the first ten minutes because of the materials and tools shortage);
  - 28% of project duration was reduced;
  - No quality issues were found during the testing. When using the conventional approach, 10 defective modules were identified);
  - Significant productivity improvement has been achieved in Module installation (130%), Off-site module manufacturing (97%), Major equipment installation (34%), and Pipework installation (32%).

#### ***Limitations***

- ❖ The size of the lean game is relatively small, and the duration of the simulation game (i.e. within one hour) is relatively short;
- ❖ Compared with the real construction site, the environment of playing the lean game is simplified. Site constraints such as weather, safety, and permit were not considered during the lab-based testing.

## 9.2 Summary of Theoretical Contributions

This research was motivated by the increasing challenges of constraint management faced by project planners when using pull planning methods in LNG construction. The main theoretical contributions of this study include:

### **(1) A TCM method that enhances the role of constraint management within pull planning methods (i.e. AWP, WFP, and LPS)**

Traditionally, shielding assignments are the main approach to improving work flow. Constraint removal in this context is passive and often late implemented. In this thesis, it is assumed that the best way to improve workflow reliability is not only to shield assignments, but also to remove the constraints on-time. In order to actively perform constraint removal, the TCM framework proposed in this thesis consists of:

- *A complete process for constraint lifecycle management from constraint identification to removal.* Constraint modelling module provides a global view of constraint relationships and interconnections, which is useful for identifying key constraints. In addition, delay impact of each constraint can be assessed at an early stage which leaves enough time for project teams to catch up with the planned schedule. Constraint monitoring includes a small cycle of constraint tracking, status updating, and checking and action. Constraint removal is executed when: (i) the maturity index of the constraint is 100%; or (ii) the maturity index can be updated to 100% based on forecasting or reliable commitment.
- *Three loops (i.e. Loop 1, 2 and 3) for managing constraints in three work-package levels (i.e. CWA, CWP, and IWP), respectively.* Loop 1 happens in the preliminary planning stage which aims to identify and monitor long lead-time constraints and align engineering and procurement plans to the construction plan. Loop 2 happens in project detailed engineering stage which aims to manage constraints from a CWP-centred perspective, and continually involve owner, engineers, purchasers, and contractors to find new constraints and detect potential constraint-removal issues. Monitoring and removing the engineering constraints and long-lead supply chain constraints should be given high priorities in this loop. Loop 3 happens in the project construction stage which aims to maintain, monitor and remove constraints from an IWP-centred perspective based on IWP look-ahead schedule. Modelling, monitoring, and removal of detailed site constraints such as materials,

equipment, tools, labour, safety, permits, weather and work space are the focus of this loop.

## **(2) A network-based method for dynamic constraint modelling and analysis**

Traditional approaches for constraint modelling are either mathematic-driven or human-driven. The former one does not have the capability of modelling all types of constraints, while the latter one cannot efficiently present the interrelationships between constraints. The network-based method proposed in this thesis can significantly address the above two challengers by leveraging the advantages of the DNA technique. There are two key modules developed within the proposed method:

- *Constraint Meta-Network*, which has two levels: CWP-oriented Constraint Meta-network Model and IWP-oriented Constraint Meta-network Model. Five different types of nodes, including agents, CWP/AWPs, engineering constraints, supply chain constraints and site constraints, are identified, along with fifteen inter-linked networks (also called sub-networks). A detailed explanation of the meta-network can be found in Chapter 5.
- *Dynamic Constraint Network Analysis*, which is key to allow project managers and involved partners to obtain a thorough understanding of the interconnections among constraints. Five measures (i.e.  $NUC_i$ ,  $VCR_i$ ,  $VIRS_i$ ,  $ODCN$  and  $IDIN$ ) are developed to analysis the network evolution. The experiment discussed in Chapter 5 demonstrates the power of these measures in detecting conflicts between construction plans and constraint-removal plans, and identifying critical constraints before and during project execution.

## **(3) A semantic method for cross-domain constraint information sharing**

Currently, constraint information is often stored in various isolated systems and databases, and uses different, usually not aligned, vocabularies and schemes. Existing solutions are too rigid and potentially cumbersome. The semantic method proposed in this thesis tackles these challenges by leveraging linked data techniques. Isolated constraint data sources are interconnected by means of ontologies, mitigating the problem of ambiguities. The pilot case study discussed in Chapter 6 demonstrates the power of this method in interlinking multi-domain constraint data, extracting required constraint information, and inferring extra constraint information. Compared with conventional approaches for data integration and sharing, the proposed semantic method enables data to be delivered in both machine- and human-readable formats. For instance, arbitrary things can be identified by URIs so that people and computers can look them up.



### 9.3 Practical Implications

This research represents an effort to help project stakeholders in LNG industry (i.e. owners, engineering managers, contractors, procurement managers, suppliers, and project planners) improve their work efficiency in constraint management including constraint identification, modelling, monitoring, and removal. Four key practical contributions are explained as follows:

**(1) The proposed hierarchical constraint management process, detailed in Chapter 4, provides a step-by-step guidance for project team to efficiently identify and remove constraints from project planning stage to the end of commissioning**

First, the constraint classification for LNG construction (as discussed in Section 4.2.1) can help project planners efficiently identify constraints for each work package. In addition, the detailed constraint management process including constraint identification, relationship mapping, removal planning, tracking, status updating, and removal (as discussed in Section 4.2.1-4.2.3), can assist project planners to well manage each constraint and make sure all of them are timely removed. The three loops (as discussed in Section 4.2.4-4.2.6) can make sure project planners focus on managing the constraints that have high priorities than others as project progresses.

**(2) The DNA-enabled constraint modelling approach, detailed in Chapter 5, ensures transparent communication and coordination among design engineers, suppliers, contractors, subcontractors, and clients**

The DNA-enabled approach can visualise the constraint meta-network in a graph, which is useful for project teams to get a quick understanding of the whole constraints and their relationships with each other. In addition, project team members can easily check the constraints that are related to a specific work package. This approach can also generate the evolution of the constraint meta-network as project progresses, which can help project participants: (i) automatically identify the critical constraints in a given time interval; (ii) automatically detect conflicts between constraint-removals plans and construction plans; (iii) automatically collect free IWPs (i.e. IWPs that have no constraints linked with) for the weekly plan development.

**(3) The Linked Data-enabled approach for constraint information sharing, detailed in Chapter 6, provides an efficient way for project participants to access constraint data across multiple domains.**

This approach can eliminate the need for project participants to reconcile various datasets because all the entities within the linked constraint data cloud have their own unique explicit identifiers (i.e. URI). With the prototype developed in Chapter 6, project participants can obtain not only the real-time status of each constraint, but also some additional useful context. For instance, if a work package, such as *IWP10001-Piping-SG-108*, needs to be released to the field, a SPARQL Query can be conducted to list all the constraints and their statuses (i.e. removed or unremoved) related to this IWP. If all the constraints are marked as “removed”, the IWP can be released. Work instructions to execute the IWP tasks can also be identified using the linked data approach.

**(4) The coordinated approach for supply-chain constraint tracking, detailed in Chapter 7, provides a practical way for using multiple sensing technologies to track constraints in LNG construction**

Information technologies play a key role in the current LNG construction industry. This study serves as the foundation for developing a cost-effective tracking solution. The advantages and disadvantages of a few commonly seen sensing technologies are discussed in Section 7.2, which is useful for project decision-makers to select the most suitable tracking technologies for their projects. In addition, the prototype developed in Chapter 7 provides a method of integrating sensor data into a 3D LNG plant model, and automatically colour-coding the model to reflect the constraint status. For instance, if a sensor (e.g. a GPS tag) indicates that an offsite fabricated LNG module has been successfully delivered to site, the colour of this module within the 3D platform will be automatically changed. The two experiments discussed in Section 7.4 provide a guideline for industry people to implement these sensing and tracking technologies.

## **9.4 Recommendations for Future Research**

According to the limitations summarised in Section 8.1, recommendations for future research and development can be drawn as follows:

**(1) Developing methods and tools for automatically generating the constraint-meta network**

The constraint-meta networks used in this thesis are created manually. The time spent is acceptable for small-scale LNG projects, however, for large-scale projects, this will become a main barrier for adopting the DNA method. A number of open source libraries/packages such as Sigma.js (Sigma 2017), Cytoscape.js (Shannon et al. 2003),

and NetworkX (Network X 2017) can be leveraged to automate the network creation and visualisation.

## **(2) Applying graph theory to the constraint network analysis**

The five indicators for measuring the constraint network in this thesis are based on a given graph. Subgraphs inside the constraint network, such as communities, are not considered. Communities are unstable patterns that can evolve in both membership and content (Oliveira et al 2014). In dynamic scenarios, communities may undergo a series of evolutionary events, such as growth, split and disappearance, which can provide another dimension to analyse the interactions among constraints, work packages, and agents. Graph theory has a well-established theoretical and mathematical foundation, which should be investigated in the future research to develop more meaningful metrics and algorithms for community constraint detection and mining.

## **(3) Integrating the cross-domain constraint information sharing system with existing enterprise data/document management systems**

In order to automatically convert application data from an application-specific format into RDF, a number of data adaptors should be developed on the top of the existing relational databases and/or document management systems. The D2RQ Platform is a system for accessing relational databases as virtual, read-only RDF graphs (D2RQ 2017). It offers RDF-based access to the content of relational databases without having to replicate it into an RDF store. Future researchers can consider to develop the system integrations based on the R2RQ platform.

## **(4) Implementing the TCM method in real LNG construction projects**

The TCM method including the approaches developed in Chapter 5-7 should be further tested with more case studies in the LNG industry. This would help to evaluate the wider applicability of the TCM as well as creating best practices for future implementation of TCM in the LNG construction industry.

## References

- Abdelsayed, M. and R. Navon (1999). An information sharing, Internet-based, system for project control. *Civil Engineering Systems* 16(3): 211-233.
- AbouRizk, S., D. Halpin, Y. Mohamed, and U. Hermann (2011). Research in modeling and simulation for improving construction engineering operations. *Journal of Construction Engineering and Management*, 137(10), 843-852.
- AbouRizk, S., and S. Hague (2009). An overview of the COSYE environment for construction simulation. *Proc., Winter Simulation Conf., IEEE*, Piscataway, NJ, 2624–2634.
- Adam, A. (2007). *Implementing electronic document and record management systems*, CRC Press.
- Akinci, B., M. Fischen, R. Levitt and R. Carlson (2002). Formalization and automation of time-space conflict analysis. *Journal of Computing in Civil Engineering* 16(2): 124-134.
- AlSehaimi, A.O., P. Tzortzopoulos, and L. Koskela (2009) Last planner system: experiences from pilot implementation in the middle East, in *17th Annual Conference of the International Group for Lean Construction IGLC 17*, Taipei, 15–17 July.
- AlSehaimi, A.O., P. Tzortzopoulos, and L. Koskela (2014) Improving construction management practice with the Last Planner System: a case study. *Engineering, Construction and Architectural Management*, 21(1), 51–64.
- Al Haj, R. A. and S. M. El-Sayegh (2015). Time–cost optimization model considering float-consumption impact. *Journal of Construction Engineering and Management* 141(5): 04015001.
- Al Sarraj, Z. M. (1990). Formal development of line-of-balance technique. *Journal of Construction Engineering and Management*, 116(4), 689-704.
- Arditi, D., and M. Z. Albulak (1986). Line-of-balance scheduling in pavement construction. *Journal of Construction Engineering and Management*, 112(3), 411-424.
- Arditi, D., O. B. Tokdemir, and K. Suh (2002). Challenges in line-of-balance scheduling. *Journal of construction engineering and management*, 128(6), 545-556.
- Autodesk (2017a). Autodesk Buzzsaw. <https://www.autodesk.com.au/products/buzzsaw/overview>.

Autodesk (2017b). Autodesk Navisworks.  
<https://www.autodesk.com.au/products/navisworks/overview>.

Ballard, G. (2000). *The last planner system of production control*, The University of Birmingham.

Ballard, G. and T. Iris (2016). Current Process Benchmark for the Last Planner System. Available at [p2sl.berkeley.edu](http://p2sl.berkeley.edu).

Balfe, N., M. C. Leva, C. Ciarapica-Alunni, and S. O'Mahoney (2016). Total project planning: Integration of task analysis, safety analysis and optimisation techniques. *Safety Science*.

Bansal, V. (2010). Use of GIS and Topology in the Identification and Resolution of Space Conflicts. *Journal of Computing in Civil Engineering* 25(2): 159-171.

Bastian, M., Heymann, S., Jacomy, M. (2009). Gephi: an open source software for exploring and manipulating networks. *International AAAI Conference on Weblogs and Social Media*.

Bauer, F. and M. Kaltenböck (2011). Linked open data: The essentials. *Edition mono/monochrom, Vienna*.

Becerik-Gerber, B., F. Jazizadeh, G. Kavulya and G. Calis (2011). Assessment of target types and layouts in 3D laser scanning for registration accuracy. *Automation in Construction* 20(5): 649-658.

Beetz, J., J. Van Leeuwen and B. De Vries (2009). IfcOWL: A case of transforming EXPRESS schemas into ontologies. *Artificial Intelligence for Engineering Design, Analysis and Manufacturing* 23(01): 89-101.

Bentley (2017). Bentley ProjectWise.  
<https://www.bentley.com/en/products/brands/projectwise>.

Berger-Wolf, T. Y. and J. Saia (2006). A framework for analysis of dynamic social networks. *Proceedings of the 12th ACM SIGKDD international conference on Knowledge discovery and data mining*, ACM.

Berners-Lee, T. (2006). Linked Data. <https://www.w3.org/DesignIssues/LinkedData.html>.

Bhatla, A., S. Y. Choe, O. Fierro and F. Leite (2012). Evaluation of accuracy of as-built 3D modeling from photos taken by handheld digital cameras. *Automation in Construction* 28(0): 116-127.

Biber, P., H. Andreasson, T. Duckett and A. Schilling (2004). 3D modeling of indoor environments by a mobile robot with a laser scanner and panoramic camera. *Intelligent Robots and Systems, 2004.(IROS 2004). Proceedings. 2004 IEEE/RSJ International Conference on, IEEE.*

Bizer, C., T. Heath and T. Berners-Lee (2009). Linked data-the story so far. *Semantic services, interoperability and web applications: emerging concepts: 205-227.*

Bizer, C., T. Heath, K. Idehen and T. Berners-Lee (2008). Linked data on the web (LDOW2008). *Proceedings of the 17th international conference on World Wide Web, ACM.*

Blackmon, T., R. Saxena and L. Song (2011). A Conceptual Framework for Total Constraint Management in Construction. *Proceedings of the 28th ISARC: 419-424.*

Boddy, S., Y. Rezgui, G. Cooper and M. Wetherill (2009). Activity awareness as an enabler for communication and network building in construction design teams. *Journal of Computing in Civil Engineering 24(5): 430-440.*

Bohn, J. S. and J. Teizer (2009). Benefits and barriers of construction project monitoring using high-resolution automated cameras. *Journal of construction engineering and management 136(6): 632-640.*

Boneh, A., S., Boneh, and R. J. Caron (1993). Constraint classification in mathematical programming. *Mathematical Programming, 61(1-3), 61-73.*

Bosc, P., M. Galibourg and G. Hamon (1988). Fuzzy querying with SQL: extensions and implementation aspects. *Fuzzy Sets and Systems 28(3): 333-349.*

Bosché, F. (2010). Automated recognition of 3D CAD model objects in laser scans and calculation of as-built dimensions for dimensional compliance control in construction. *Advanced engineering informatics 24(1): 107-118.*

Brewer, A., N. Sloan and T. L. Landers (1999). Intelligent tracking in manufacturing. *Journal of intelligent manufacturing 10(3-4): 245-250.*

Brickley, D. and L. Miller (2007). FOAF vocabulary specification 0.91, Citeseer.

Brilakis, I., M.-W. Park and G. Jog (2011). Automated vision tracking of project related entities. *Advanced Engineering Informatics 25(4): 713-724.*

Burt, R. S., N. NOHRIA and R. Eccles (1992). Networks and organizations: structure, form and action. *Networks and organizations: structure, form and action*.

Butts, C. T. (2003). Network inference, error, and informant (in) accuracy: a Bayesian approach. *social networks* 25(2): 103-140.

Caldas, C. H., D. G. Torrent and C. T. Haas (2006). Using global positioning system to improve materials-locating processes on industrial projects. *Journal of Construction Engineering and Management* 132(7): 741-749.

Camerer, C. F., and E. Fehr (2004). Measuring social norms and preferences using experimental games: A guide for social scientists. *Foundations of human sociality: Economic experiments and ethnographic evidence from fifteen small-scale societies*, 97, 55-95.

Carley, K. M. (2003). *Dynamic network analysis*, Citeseer.

Carley, K. M., J. Diesner, J. Reminga and M. Tsvetovat (2007). Toward an interoperable dynamic network analysis toolkit. *Decision Support Systems* 43(4): 1324-1347.

Chae, S., and T. Yoshida (2010). Application of RFID technology to prevention of collision accident with heavy equipment. *Automation in Construction*, 19(3), 368-374.

Chan, W. and H. Hu (2002). Constraint programming approach to precast production scheduling. *Journal of Construction Engineering and Management* 128(6): 513-521.

Chassiakos, A. and S. Sakellariopoulos (2008). A web-based system for managing construction information. *Advances in Engineering Software* 39(11): 865-876.

Chassiakos, A. P. and S. P. Sakellariopoulos (2005). Time-cost optimization of construction projects with generalized activity constraints. *Journal of Construction Engineering and Management* 131(10): 1115-1124.

Chen, K., W. Lu, Y. Peng, S. Rowlinson and G. Q. Huang (2015). Bridging BIM and building: From a literature review to an integrated conceptual framework. *International journal of project management* 33(6): 1405-1416.

Cheng, F., H. Li, Y.-W. Wang, M. Skitmore and P. Forsythe (2013). Modeling resource management in the building design process by information constraint Petri nets. *Automation in Construction* 29: 92-99.

- Cheng, T., M. Venugopal, J. Teizer and P. Vela (2011). Performance evaluation of ultra wideband technology for construction resource location tracking in harsh environments. *Automation in Construction* 20(8): 1173-1184.
- Chi, H.-L., J. Wang, X. Wang, M. Truijens and P. Yung (2014). A Conceptual Framework of Quality-Assured Fabrication, Delivery and Installation Processes for Liquefied Natural Gas (LNG) Plant Construction. *Journal of Intelligent & Robotic Systems*: 1-16.
- Chinowsky, P. S., J. Diekmann and J. O'Brien (2009). Project organizations as social networks. *Journal of Construction Engineering and Management*.
- Choo, H. J., I. D. Tommelein, G. Ballard and T. R. Zabelle (1999). WorkPlan: Constraint-based database for work package scheduling. *Journal of Construction Engineering and Management* 125(3): 151-160.
- Chua, D. and L. Shen (2005). Key constraints analysis with integrated production scheduler. *Journal of construction engineering and management* 131(7): 753-764.
- Chua, D., L. Shen and S. Bok (2003). Constraint-based planning with integrated production scheduler over internet. *Journal of Construction Engineering and Management* 129(3): 293-301.
- CII (2013). Advanced Work Packaging: Design through Workface Execution. *Construction Industry Institute, Implementation Resource 272-2, Version 3.0*.
- Coman, A. and B. Ronen (2007). Managing strategic and tactical constraints in the hi-tech industry. *International Journal of Production Research*, 45 (4), 779–788.
- Costin, A. M., J. Teizer and B. Schoner (2015). RFID and BIM-enabled worker location tracking to support real-time building protocol and data visualization. *Journal of Information Technology in Construction (ITcon)* 20(29): 495-517.
- Curry, E., J. O'Donnell, E. Corry, S. Hasan, M. Keane, and S. O'Riain (2013). Linking building data in the cloud: Integrating cross-domain building data using linked data. *Advanced Engineering Informatics*, 27(2), 206-219.
- D2RQ (2017). Assessing Relational Databases as Virtual RDF Graphs. available from: <http://d2rq.org/>.



- Dave, B., S. Kubler, K. Främling, and L. Koskela (2016). Opportunities for enhanced lean construction management using Internet of Things standards. *Automation in Construction*, 61, 86-97.
- Dawood, N., A. Akinsola and B. Hobbs (2002). Development of automated communication of system for managing site information using internet technology. *Automation in Construction* 11(5): 557-572.
- Dawood, N. and E. Sriprasert (2006). Construction scheduling using multi - constraint and genetic algorithms approach. *Construction Management and Economics* 24(1): 19-30.
- Demian, P. and D. Walters (2014). The advantages of information management through building information modelling. *Construction Management and Economics* 32(12): 1153-1165.
- Demiralp, G., G. Guven and E. Ergen (2012). Analyzing the benefits of RFID technology for cost sharing in construction supply chains: A case study on prefabricated precast components. *Automation in Construction* 24: 120-129.
- Demairy, E. (2017). Semantic Web Import. Available at: <https://gephi.org/plugins/#/plugin/semantic>.
- Deng, Z., H. Li, C. Tam, Q. Shen and P. Love (2001). An application of the Internet-based project management system. *Automation in construction* 10(2): 239-246.
- Di Marco, M. K., J. E. Taylor and P. Alin (2010). Emergence and role of cultural boundary spanners in global engineering project networks. *Journal of Management in Engineering* 26(3): 123-132.
- Diesner, J. and K. M. Carley (2004). Revealing social structure from texts. *Causal mapping for research in information technology*: 81.
- DiGiampaolo, E. and F. Martinelli (2014). Mobile robot localization using the phase of passive UHF RFID signals. *IEEE Transactions on Industrial Electronics* 61(1): 365-376.
- Eastman, C., P. Teicholz, R. Sacks and K. Liston (2011). *BIM handbook: A guide to building information modeling for owners, managers, designers, engineers and contractors*, John Wiley & Sons.
- El-Kholy, A. (2013). New aspects in time-cost tradeoff analysis. *Journal of Management in Engineering* 31(4): 04014051.

- El-Omari, S. and O. Moselhi (2008). Integrating 3D laser scanning and photogrammetry for progress measurement of construction work. *Automation in construction* 18(1): 1-9.
- El Kadiri, S. and D. Kiritsis (2015). Ontologies in the context of product lifecycle management: state of the art literature review. *International Journal of Production Research* 53(18): 5657-5668.
- El-Sabek, L. M., and B. Y. McCabe (2018). Framework for Managing Integration Challenges of Last Planner System in IMPs. *Journal of Construction Engineering and Management*, 144(5), 04018022.
- EnergyQuest and APPEA (2014). Oil and Gas Industry Cost Trends. Available from: [http://www.aie.org.au/AIE/Documents/APPEA-Cost-Report\\_Final.pdf](http://www.aie.org.au/AIE/Documents/APPEA-Cost-Report_Final.pdf).
- Ergen, E., B. Akinci and R. Sacks (2007). Tracking and locating components in a precast storage yard utilizing radio frequency identification technology and GPS. *Automation in construction* 16(3): 354-367.
- EY (2014). Oil and Gas Capital Projects Series: Spotlight on Oil and Gas Megaprojects. *EYGM Limited*. Available at: <http://www.ey.com/Publication/vwLUAssets/EY-spotlight-on-oil-and-gas-megaprojects/%24FILE/EY-spotlight-on-oil-and-gas-megaprojects.pdf>
- Fang, Y., Y. K. Cho, S. Zhang and E. Perez (2016). Case Study of BIM and Cloud-Enabled Real-Time RFID Indoor Localization for Construction Management Applications. *Journal of Construction Engineering and Management* 142(7): 05016003.
- Feng, C.-W., L. Liu and S. A. Burns (1997). Using genetic algorithms to solve construction time-cost trade-off problems. *Journal of computing in civil engineering* 11(3): 184-189.
- Fensel, D., F. Van Harmelen, I. Horrocks, D. L. McGuinness and P. F. Patel-Schneider (2001). OIL: An ontology infrastructure for the semantic web. *IEEE intelligent systems* 16(2): 38-45.
- Fernandez-Solis, J. L., V. Porwal, S. Lavy, A. Shafaat, Z. K. Rybkowski, K. Son and N. Lagoo (2012). Survey of motivations, benefits, and implementation challenges of last planner system users. *Journal of Construction Engineering and Management* 139(4): 354-360.
- Fiatech (2011). An Introduction to ISO 15926. [http://www.fiatech.org/images/stories/techprojects/project\\_deliverables/iso-intro-ver1.pdf](http://www.fiatech.org/images/stories/techprojects/project_deliverables/iso-intro-ver1.pdf).

- Forcada, N., M. Casals, A. Fuertes, M. Gangoellés and X. Roca (2010). A web-based system for sharing and disseminating research results: The underground construction case study. *Automation in Construction* 19(4): 458-474.
- Fortineau, V., T. Paviot and S. Lamouri (2013). Improving the interoperability of industrial information systems with description logic-based models—the state of the art. *Computers in Industry* 64(4): 363-375.
- Fox, S. and J. Hietanen (2007). Interorganizational use of building information models: potential for automational, informational and transformational effects. *Construction Management and Economics* 25(3): 289-296.
- Golparvar-Fard, M., J. Bohn, J. Teizer, S. Savarese and F. Peña-Mora (2011). Evaluation of image-based modeling and laser scanning accuracy for emerging automated performance monitoring techniques. *Automation in Construction* 20(8): 1143-1155.
- Golparvar-Fard, M., F. Peña-Mora and S. Savarese (2012). Automated progress monitoring using unordered daily construction photographs and IFC-based building information models. *Journal of Computing in Civil Engineering* 29(1).
- González, V. A., F. Orozco, B. Senior, J. Ingle, E. Forcael and L. F. Alarcón (2015). LEBSCO: lean-based simulation game for construction management classrooms. *Journal of Professional Issues in Engineering Education and Practice* 141(4): 04015002.
- Grilo, A. and R. Jardim-Goncalves (2010). Value proposition on interoperability of BIM and collaborative working environments. *Automation in Construction* 19(5): 522-530.
- Halpin, D. W. (1977). CYCLONE-method for modeling job site processes. *Journal of the construction division*, 103(ASCE 13234 Proceeding).
- Hamdi, O. (2013). *Advanced Work Packaging from project definition through site execution: driving successful implementation of WorkFace Planning*. The University of Texas at Austin, Austin.
- Hamzeh, F.R. (2009) *Improving construction workflow-The role of production planning and control*, University of California, Berkeley.
- Hamzeh, F.R., Ballard, G. and Tommelein, I.D. (2008) Improving construction workflow-the connective role of lookahead planning, in *Proceedings for the 16th Annual Conference of the International Group for Lean Construction*, Manchester, pp. 635–46.

- Hamzeh, F.R., Zankoul, E. and Rouhana, C. (2015) How can ‘tasks made ready’ during lookahead planning impact reliable workflow and project duration? *Construction Management and Economics*, 33(4), 243–58.
- Hartig, O., C. Bizer and J.-C. Freytag (2009). Executing SPARQL queries over the web of linked data. *The Semantic Web-ISWC 2009*: 293-309.
- Hashash, Y., J. Oliveira Filho, Y. Su and L. Liu (2005). *3D laser scanning for tracking supported excavation construction. Site Characterization and Modeling*: 1-10.
- Hausenblas, M. (2009). Exploiting linked data to build web applications. *IEEE Internet Computing* 13(4).
- Health, T. (2009). Linked Data? Web of Data? Semantic Web? WTF? <http://tomheath.com/blog/2009/03/linked-data-web-of-data-semantic-web-wtf/>.
- Heath, T. and C. Bizer (2011). Linked data: Evolving the web into a global data space. *Synthesis lectures on the semantic web: theory and technology* 1(1): 1-136.
- Hegazy, T. (1999). Optimization of resource allocation and leveling using genetic algorithms. *Journal of construction engineering and management* 125(3): 167-175.
- Höhn, P. A. (2014). Classification of constraints and degrees of freedom for quadratic discrete actions. *Journal of Mathematical Physics*, 55(11), 113506.
- Hou, L., X. Wang, J. Wang, and M. Truijens (2014). An integration framework of advanced technologies for productivity improvement for LNG mega-projects. *Journal of Information Technology in Construction (ITcon)*, 19(22), 360-382.
- Huesemann, S. (2006). Information sharing across multiple humanitarian organizations—a web-based information exchange platform for project reporting. *Information Technology and Management* 7(4): 277-291.
- Ikonen, J., A. Knutas, H. Hämäläinen, M. Ihonen, J. Porras and T. Kallonen (2013). Use of embedded RFID tags in concrete element supply chains. *Journal of Information Technology in Construction (ITcon)* 18(7): 119-147.
- Ingram, S., D. Harmer and M. Quinlan (2004). Ultrawideband indoor positioning systems and their use in emergencies. *Position Location and Navigation Symposium, 2004. PLANS 2004*, IEEE.

Initiative, D. C. M. (2004). Dublin core metadata element set, version 1.1: Reference description. <http://dublincore.org/documents/dces/>.

Isaac, S. and R. Navon (2014). Can project monitoring and control be fully automated? *Construction Management and Economics* 32(6): 495-505.

ISO15926 (2015). ISO 15926 Architecture. <http://15926.org/topics/architecture/index.htm>.

ISO (2003). Industrial automation systems and integration — Integration of life-cycle data for process plants including oil and gas production facilities — Part 2: Data model. <https://www.iso.org/standard/29557.html>.

ISO (2004). Industrial automation systems and integration -- Integration of life-cycle data for process plants including oil and gas production facilities -- Part 1: Overview and fundamental principles. <https://www.iso.org/standard/29556.html>.

ISO (2007). Industrial automation systems and integration -- Integration of life-cycle data for process plants including oil and gas production facilities -- Part 4: Initial reference data. <https://www.iso.org/standard/41329.html>.

ISO (2009). Industrial automation systems and integration -- Integration of life-cycle data for process plants including oil and gas production facilities -- Part 3: Reference data for geometry and topology. <https://www.iso.org/standard/42875.html>.

ISO (2011a). Industrial automation systems and integration -- Integration of life-cycle data for process plants including oil and gas production facilities -- Part 7: Implementation methods for the integration of distributed systems: Template methodology. <https://www.iso.org/standard/52455.html>.

ISO (2011b). Industrial automation systems and integration -- Integration of life-cycle data for process plants including oil and gas production facilities -- Part 8: Implementation methods for the integration of distributed systems: Web Ontology Language (OWL) implementation. <https://www.iso.org/standard/52456.html>.

ISO (2013). Industrial automation systems and integration -- Integration of life-cycle data for process plants including oil and gas production facilities -- Part 6: Methodology for the development and validation of reference data. <https://www.iso.org/standard/56819.html>.

- ISO (2015). Industrial automation systems and integration -- Integration of life-cycle data for process plants including oil and gas production facilities -- Part 11: Methodology for simplified industrial usage of reference data. <https://www.iso.org/standard/57859.html>.
- Jackson, C. (2011). Research with experimental games: questioning practice and interpretation. *Progress in Development Studies*, 11(3), 229-241.
- Järvelä, S., I. Ekman, J. M. Kivikangas, and N. Ravaja (2014). A practical guide to using digital games as an experiment stimulus. *Transactions of the Digital Games Research Association*, 1(2).
- Jaśkowski, P. and A. Sobotka (2006). Scheduling construction projects using evolutionary algorithm. *Journal of Construction Engineering and Management* 132(8): 861-870.
- Jang, J. (2008). Improving the make-ready process and forecasting project performance using performance of the make-ready process. State University of New York College of Environmental Science and Forestry.
- Jeffery, S. R., M. Garofalakis and M. J. Franklin (2006). Adaptive cleaning for RFID data streams. *Proceedings of the 32nd international conference on Very large data bases*, VLDB Endowment.
- Jena, A. (2015). A free and open source Java framework for building Semantic Web and Linked Data applications. Available online: [jena.apache.org/](http://jena.apache.org/)(accessed on 28 April 2015).
- Johnston, G. P. and D. V. Bowen (2005). The benefits of electronic records management systems: a general review of published and some unpublished cases. *Records Management Journal* 15(3): 131-140.
- Kang, T. W., and C.-H. Hong, (2015). A study on software architecture for effective BIM/GIS-based facility management data integration. *Automation in Construction*, 54, 25-38.
- Kaplan, E. and C. Hegarty (2005). *Understanding GPS: principles and applications*, Artech house.
- Karan, E. P. and J. Irizarry (2015). Extending BIM interoperability to preconstruction operations using geospatial analyses and semantic web services. *Automation in Construction*, 53, 1-12.
- Karagiannis, D. and R. A. Buchmann (2016). Linked open models: extending linked open data with conceptual model information. *Information Systems* 56: 174-197.

- Kasim, N. B. (2008). *Improving materials management on construction projects*, © Narimah Binti Kasim.
- Kassem, M., N. Iqbal, G. Kelly, S. Lockley and N. Dawood (2014). Building information modelling: protocols for collaborative design processes. *Journal of Information Technology in Construction (ITcon)* 19: 126-149.
- Kelm, A., L. Laußat, A. Meins-Becker, D. Platz, M. J. Khazaei, A. M. Costin, M. Helmus and J. Teizer (2013). Mobile passive Radio Frequency Identification (RFID) portal for automated and rapid control of Personal Protective Equipment (PPE) on construction sites. *Automation in Construction* 36: 38-52.
- Kempe, D., J. Kleinberg and É. Tardos (2003). Maximizing the spread of influence through a social network. *Proceedings of the ninth ACM SIGKDD international conference on Knowledge discovery and data mining*, ACM.
- Khoury, H. M. and V. R. Kamat (2009). Evaluation of position tracking technologies for user localization in indoor construction environments. *Automation in Construction* 18(4): 444-457.
- Kim, B. C., H. Tejjeler, D. Mun and S. Han (2011). Integration of distributed plant lifecycle data using ISO 15926 and Web services. *Annals of nuclear energy* 38(11): 2309-2318.
- Kim, C., B. Kim and H. Kim (2013). 4D CAD model updating using image processing-based construction progress monitoring. *Automation in Construction* 35: 44-52.
- Kim, C., H. Son and C. Kim (2013). Automated construction progress measurement using a 4D building information model and 3D data. *Automation in Construction* 31: 75-82.
- Kim, C., H. Son and C. Kim (2013). Fully automated registration of 3D data to a 3D CAD model for project progress monitoring. *Automation in Construction*.
- Kim, S., S. Kim, and J. Yang (2016). Extraction and Analysis of Construction Phase Risk Factors in High-rise Construction Project. *Korean Journal of Construction Engineering and Management*, 17(2), 90-98.
- Kiryakov, A., D. Ognyanoff, R. Velkov, Z. Tashev and I. Peikov (2009). LDSR: Materialized Reason-able View to the Web of Linked Data. *RuleML Challenge*.
- Kleinberg, J. (2002). Small-world phenomena and the dynamics of information. *Advances in neural information processing systems* 1: 431-438.

- Ko, C.-H. (2009). RFID-based building maintenance system. *Automation in Construction* 18(3): 275-284.
- Kolovski, V., Z. Wu and G. Eadon (2010). Optimizing enterprise-scale OWL 2 RL reasoning in a relational database system. *The Semantic Web–ISWC 2010*: 436-452.
- Kong, S. C., H. Li, T. P. Hung, J. W. Shi, D. Castro-Lacouture and M. Skibniewski (2004). Enabling information sharing between E-commerce systems for construction material procurement. *Automation in construction* 13(2): 261-276.
- Koo, C., T. Hong and S. Kim (2015). An integrated multi-objective optimization model for solving the construction time-cost trade-off problem. *Journal of Civil Engineering and Management* 21(3): 323-333.
- Koskela, L. (2000). *An exploration towards a production theory and its application to construction*, VTT Technical Research Centre of Finland.
- KPMG (2015). Unlocking the supply chain for LNG project success. *kpmg.com/energy*.
- Lau, E., and J. Kong (2006). Identification of constraints in construction projects to improve performance. In *Proceedings of the Joint Conference on Construction, Culture, Innovation and Management, Dubai, November* (pp. 26-29).
- LCI (2007), The Last Planner Production System Workbook: Improving Reliability in Planning and Work Flow. *Lean Construction Institute*. Available from: <https://www.leanconstruction.org/wp-content/uploads/2016/06/Last-Planner-Workbook-rev5.pdf>
- Le, T. and H. D. Jeong (2016). Interlinking life-cycle data spaces to support decision making in highway asset management. *Automation in construction* 64: 54-64.
- Ledesma, D., J. Henderson, and N. Palmer (2014). The Future of Australian LNG Exports: Will domestic challenges limit the development of future LNG export capacity? *Oxford Institute for Energy Studies*.
- Lee, J. H., J.-H. Song, K.-S. Oh, and N. Gu (2013). Information lifecycle management with RFID for material control on construction sites. *Advanced Engineering Informatics*, 27(1), 108-119.



- Lee, D.-Y., H.-I. Chi, J. Wang, X. Wang and C.-S. Park (2016). A linked data system framework for sharing construction defect information using ontologies and BIM environments. *Automation in Construction* 68: 102-113.
- Leung, M. Y., J. Yu, and Y. S. Chan (2013). Focus group study to explore critical factors of public engagement process for mega development projects. *Journal of Construction Engineering and Management*, 140(3), 04013061.
- Leung, M. Y., and I. Y. S. Chan (2011). Exploring stressors of Hong Kong expatriate construction professionals in Mainland China: focus group study. *Journal of Construction Engineering and Management*, 138(1), 78-88.
- Li, H., G. Chan, J. K. W. Wong and M. Skitmore (2016). Real-time locating systems applications in construction. *Automation in Construction* 63: 37-47.
- Li, H., Z. Chen and C. T. Wong (2003). Barcode technology for an incentive reward program to reduce construction wastes. *Computer - Aided Civil and Infrastructure Engineering* 18(4): 313-324.
- Li, H. and P. Love (1997). Using improved genetic algorithms to facilitate time-cost optimization. *Journal of Construction Engineering and management* 123(3): 233-237.
- Li, Y., Y. Lu, D. Li and L. Ma (2015). Metanetwork Analysis for Project Task Assignment. *Journal of Construction Engineering and Management* 141(12): 04015044.
- Lin, Y.-C., W.-F. Cheung and F.-C. Siao (2014). Developing mobile 2D barcode/RFID-based maintenance management system. *Automation in Construction* 37: 110-121.
- Lindhard, S. and S. Wandahl (2014) Scheduling of large, complex, and constrained construction projects: an exploration of LPS application. *International Journal of Project Organisation and Management*, 6(3), 237–53.
- Liston, K., M. Fischer and T. Winograd (2003). Focused sharing of information for multidisciplinary decision making by project teams. *Journal of Information Technology in Construction (ITcon)* 6(6): 69-82.
- Liu, H., H. Darabi, P. Banerjee and J. Liu (2007). Survey of wireless indoor positioning techniques and systems. *IEEE Transactions on Systems, Man, and Cybernetics, Part C (Applications and Reviews)* 37(6): 1067-1080.

- Liu, X., J. Shannon, H. Voun, M. Truijens, H.-L. Chi and X. Wang (2014). Spatial and temporal analysis on the distribution of active radio-frequency identification (RFID) tracking accuracy with the kriging method. *Sensors* 14(11): 20451-20467.
- Loosemore, M. (1998). Social network analysis: using a quantitative tool within an interpretative context to explore the management of construction crises. *Engineering, Construction and Architectural Management* 5(4): 315-326.
- Martinez, J. C., and P. G. Ioannou (1996). State-based probabilistic scheduling using Stroboscope's CPM add-on. *Proc., Constr. Congr. V, ASCE*, Reston, VA, 438-445.
- Mead, C. N. (2006). Data interchange standards in healthcare it-computable semantic interoperability: Now possible but still difficult. do we really need a better mousetrap? *Journal of Healthcare Information Management* 20(1): 71.
- Meditkos, G. and N. Bassiliades (2010). DLEJena: A practical forward-chaining OWL 2 RL reasoner combining Jena and Pellet. *Web Semantics: Science, Services and Agents on the World Wide Web* 8(1): 89-94.
- Mohamed, Y., D. Borrego, L. Francisco, M. Al-Hussein, S. AbouRizk, and U. Hermann (2007). Simulation-based scheduling of module assembly yards: Case study. *Engineering, Construction and Architectural Management*, 14(3), 293-311.
- Montaser, A. and O. Moselhi (2014). RFID indoor location identification for construction projects. *Automation in Construction* 39: 167-179.
- Moon, H., H. Kim, C. Kim, and L. Kang (2014). Development of a schedule-workspace interference management system simultaneously considering the overlap level of parallel schedules and workspaces. *Automation in Construction*, 39, 93-105.
- Moreno, J. L. (1960). The sociometry reader.
- Musen, M. A. (2015). The Protégé project: A look back and a look forward. *AI matters* 1(4): 4-12.
- Nassar, K., W. Thabet and Y. Beliveau (2003). Building assembly detailing using constraint-based modeling. *Automation in Construction* 12(4): 365-379.
- Navon, R. and O. Berkovich (2006). An automated model for materials management and control. *Construction Management and Economics* 24(6): 635-646.

Nayak, N. V. and J. E. Taylor (2009). Offshore outsourcing in global design networks. *Journal of Management in Engineering* 25(4): 177-184.

NetworkX (2017). Software for complex networks. Available from: <https://networkx.github.io/>

Nieto-Morote, A. and F. Ruz-Vila (2011). Last planner control system applied to a chemical plant construction. *Journal of Construction Engineering and Management* 138(2): 287-293.

Niknam, M. and S. Karshenas (2015). Integrating distributed sources of information for construction cost estimating using Semantic Web and Semantic Web Service technologies. *Automation in Construction* 57: 222-238.

Noy, N. F. and D. L. McGuinness (2001). Ontology development 101: A guide to creating your first ontology, Stanford knowledge systems laboratory technical report KSL-01-05 and Stanford medical informatics technical report SMI-2001-0880, Stanford, CA.

Noy, N. F. and M. A. Musen (2000). Algorithm and tool for automated ontology merging and alignment. *Proceedings of the 17th National Conference on Artificial Intelligence (AAAI-00)*. Available as SMI technical report SMI-2000-0831.

Oloufa, A. A., M. Ikeda and H. Oda (2003). Situational awareness of construction equipment using GPS, wireless and web technologies. *Automation in Construction* 12(6): 737-748.

O Nyumba, T., K. Wilson, C. J. Derrick, and N. Mukherjee (2018). The use of focus group discussion methodology: Insights from two decades of application in conservation. *Methods in Ecology and Evolution*, 9(1), 20-32.

Park, C.-S., D.-Y. Lee, O.-S. Kwon and X. Wang (2013). A framework for proactive construction defect management using BIM, augmented reality and ontology-based data collection template. *Automation in Construction* 33: 61-71.

Park, H., S. H. Han, E. M. Rojas, J. Son and W. Jung (2010). Social network analysis of collaborative ventures for overseas construction projects. *Journal of construction engineering and management* 137(5): 344-355.

Patton, M. Q. (1990). *Qualitative evaluation and research methods*, Sage, Newbury Park, CA.

Pattison, P., K. Carley and R. Breiger (2003). *Dynamic Social Network Modeling and Analysis:: Workshop Summary and Papers*, National Academies Press.

- Pauwels, P., D. Van Deursen, J. De Roo, T. Van Ackere, R. De Meyer, R. Van de Walle and J. Van Campenhout (2011). Three-dimensional information exchange over the semantic web for the domain of architecture, engineering, and construction. *Artificial Intelligence for Engineering Design, Analysis and Manufacturing* 25(04): 317-332.
- Perng, Y. H., Y. K. Juan, and S. F. Chien (2006). Exploring the bidding situation for economically most advantageous tender projects using a bidding game. *Journal of Construction Engineering and Management*, 132(10), 1037-1042.
- Plume, J. and J. Mitchell (2007). Collaborative design using a shared IFC building model— Learning from experience. *Automation in Construction* 16(1): 28-36.
- PMI, P. M. I. (1987). Project Management Body of Knowledge (PMBOK), Project Management Institute.
- PMP, G. R. (2009). *Schedule for Sale: Workface Planning for Construction Projects*, AuthorHouse.
- Pour Rahimian, F., R. Ibrahim, J. Wang, X. Wang, W. Shou and B. Xu (2014). Integrating BIM and augmented reality for interactive architectural visualisation. *Construction Innovation* 14(4): 453-476.
- Powell, W. W. and S. Grodal (2005). Networks of innovators. *The Oxford handbook of innovation*: 56-85.
- Pradhananga, N. and J. Teizer (2013). Automatic spatio-temporal analysis of construction site equipment operations using GPS data. *Automation in Construction* 29: 107-122.
- Pryke, S. (2012). *Social network analysis in construction*, John Wiley & Sons.
- Pultar, M. (1990) Progress-based construction scheduling. *Journal of Construction Engineering and Management*, 116 (4), 670–88.
- Qian, J.-P., X.-T. Yang, X.-M. Wu, L. Zhao, B.-L. Fan and B. Xing (2012). A traceability system incorporating 2D barcode and RFID technology for wheat flour mills. *Computers and electronics in agriculture* 89: 76-85.
- Richert, T. (2017). What is the Last Planner System? *Lean Construction Blog*. Available from: <http://leanconstructionblog.com/What-is-the-Last-Planner-System.html>

- Ronen, B. and Y. Spector (1992). Managing system constraints: a cost/utilisation approach. *International Journal of Production Research*, 30 (9), 2045–2061.
- Ruan, X., E. G. Ochieng, A. D. F. Price and C. Egbu (2013). Time for a real shift to relations: appraisal of Social Network Analysis applications in the UK construction industry. *Construction Economics and Building* 13(1): 92-105.
- Sabesan, S., M. Crisp, R. V. Penty and I. H. White (2012). An error free passive UHF RFID system using a new form of wireless signal distribution. *RFID (RFID), 2012 IEEE International Conference on*, IEEE.
- Sacks, R., A. Esquenazi, and M. Goldin (2007). LEAPCON: Simulation of lean construction of high-rise apartment buildings. *Journal of Construction Engineering and Management*, 133(7), 529-539.
- Sacks, R., and M. Goldin (2007). Lean management model for construction of high-rise apartment buildings. *Journal of construction engineering and Management*, 133(5), 374-384.
- Sacks, R., M. Radosavljevic and R. Barak (2010). Requirements for building information modeling based lean production management systems for construction. *Automation in Construction* 19(5): 641-655.
- Schmidt, M., L. Thoroe and M. Schumann (2013). RFID and barcode in manufacturing logistics: interface concept for concurrent operation. *Information systems management* 30(2): 100-115.
- Scott, J. (2012). *Social network analysis*, Sage.
- Shahi, A., A. Aryan, J. S. West, C. T. Haas and R. C. Haas (2012). Deterioration of UWB positioning during construction. *Automation in Construction* 24: 72-80.
- Shannon, P., A. Markiel, O. Ozier, N. S. Baliga, J. T. Wang, D. Ramage, N. Amin, B. Schwikowski, and Ideker, T. (2003). Cytoscape: a software environment for integrated models of biomolecular interaction networks. *Genome research*, 13(11), 2498-2504.
- Shih, N.-J., H.-J. Wang, C.-Y. Lin and C.-Y. Liao (2007). 3D scan for the digital preservation of a historical temple in Taiwan. *Advances in engineering software* 38(7): 501-512.
- Shin, T.-H., S. Chin, S.-W. Yoon and S.-W. Kwon (2011). A service-oriented integrated information framework for RFID/WSN-based intelligent construction supply chain management. *Automation in Construction* 20(6): 706-715.

Shou, W., J. Wang, X. Wang and H. Y. Chong (2014). A Comparative Review of Building Information Modelling Implementation in Building and Infrastructure Industries. *Archives of Computational Methods in Engineering*: 1-18.

Sigma (2017). Get started with sigma. Available from: <http://sigmajournal.org/>.

Slotman, T. (2007). Planning of Mega-Projects: Influence of execution planning on project performance.

Song, J., C. T. Haas and C. H. Caldas (2006). Tracking the location of materials on construction job sites. *Journal of Construction Engineering and Management* 132(9): 911-918.

Sriprasert, E. and N. Dawood (2003). Multi-constraint information management and visualisation for collaborative planning and control in construction. *Electronic Journal of Information Technology in Construction*.

Suhail, S. A., and R. H. Neale (1994). CPM/LOB: New methodology to integrate CPM and line of balance. *Journal of Construction Engineering and Management*, 120(3), 667-684.

Sure, Y., M. Erdmann, J. Angele, S. Staab, R. Studer and D. Wenke (2002). OntoEdit: Collaborative ontology development for the semantic web. *International Semantic Web Conference*, Springer.

Surmann, H., A. Nüchter and J. Hertzberg (2003). An autonomous mobile robot with a 3D laser range finder for 3D exploration and digitalization of indoor environments. *Robotics and Autonomous Systems* 45(3): 181-198.

Tarjan, R. (1972). Depth-first search and linear graph algorithms. *SIAM journal on computing* 1(2): 146-160.

TechInvestLab (2015). dot15926: Ontology modeller, semantic data editor and reasoner designed for ISO 15926 compliant engineering data. <https://github.com/TechInvestLab/dot15926>.

Tommelein, I. D., D. R. Riley, and G. A. Howell (1999). Parade game: Impact of work flow variability on trade performance. *Journal of construction engineering and management*, 125(5), 304-310.

Torrent, D. G. and C. H. Caldas (2009). Methodology for automating the identification and localization of construction components on industrial projects. *Journal of Computing in Civil Engineering* 23(1): 3-13.

Tsai, C.-Y., T.-H. Sun and J.-X. Huang (2006). A web-based XML information sharing system for collaborative product development. *International journal of production research* 44(15): 2955-2976.

Turkan, Y., F. Bosche, C. T. Haas and R. Haas (2012). Automated progress tracking using 4D schedule and 3D sensing technologies. *Automation in Construction* 22: 414-421.

van den Berg, M., H. Voordijk, A. Adriaanse, and T. Hartmann (2017). Experiencing Supply Chain Optimizations: A Serious Gaming Approach. *Journal of construction engineering and management*, 143(11), 04017082.

Walters, R., E. Jaselskis, J. Zhang, K. Mueller and M. Kaewmorachoen (2008). Using scanning lasers to determine the thickness of concrete pavement. *Journal of construction engineering and management* 134(8): 583-591.

Wang, J., W. Shou, X. Wang and P. Wu (2016). Developing and evaluating a framework of total constraint management for improving workflow in construction. *Construction Management and Economics* 34(12): 859-874.

Wang, J., W. Sun, W. Shou, X. Wang, C. Wu, H.-Y. Chong, Y. Liu and C. Sun (2014). Integrating BIM and LiDAR for Real-Time Construction Quality Control. *Journal of Intelligent & Robotic Systems*: 1-16.

Wang, L.-C., Y.-C. Lin and P. H. Lin (2007). Dynamic mobile RFID-based supply chain control and management system in construction. *Advanced Engineering Informatics* 21(4): 377-390.

Wang, X., M. Truijens, L. Hou, Y. Wang and Y. Zhou (2014). Integrating Augmented Reality with Building Information Modeling: Onsite construction process controlling for liquefied natural gas industry. *Automation in Construction* 40: 96-105.

Wasserman, S. and K. Faust (1994). *Social network analysis: Methods and applications*, Cambridge university press.

Wikipedia (2017). ISO 15926. [https://en.wikipedia.org/wiki/ISO\\_15926](https://en.wikipedia.org/wiki/ISO_15926).

Wong, K., H. Unsal, J. E. Taylor and R. E. Levitt (2009). Global dimension of robust project network design. *Journal of Construction Engineering and Management* 136(4): 442-451.

- Woo, S., S. Jeong, E. Mok, L. Xia, C. Choi, M. Pyeon and J. Heo (2011). Application of WiFi-based indoor positioning system for labor tracking at construction sites: A case study in Guangzhou MTR. *Automation in Construction* 20(1): 3-13.
- Yang, J., O. Arif, P. A. Vela, J. Teizer and Z. Shi (2010). Tracking multiple workers on construction sites using video cameras. *Advanced Engineering Informatics* 24(4): 428-434.
- Yang, J., T. Cheng, J. Teizer, P. A. Vela and Z. Shi (2011). A performance evaluation of vision and radio frequency tracking methods for interacting workforce. *Advanced Engineering Informatics* 25(4): 736-747.
- Shi, J., and S. M. AbouRizk (1997). Resource-based modeling for construction simulation. *Journal of construction engineering and management*, 123(1), 26-33.
- Spector Y. (2011) Theory of constraint methodology where the constraint is the business model, *International Journal of Production Research*, 49:11, 3387-3394, DOI: 10.1080/00207541003801283
- Young, D. A., C. T. Haas, P. Goodrum and C. Caldas (2011). Improving construction supply network visibility by using automated materials locating and tracking technology. *Journal of Construction Engineering and Management* 137(11): 976-984.
- Zaheer, A., R. Gulati and N. Nohria (2000). Strategic networks. *Strategic management journal* 21(3): 203.
- Zareei, S. (2018). Project scheduling for constructing biogas plant using critical path method. *Renewable and Sustainable Energy Reviews*, 81, 756-759.
- Zhang, C. and D. Arditi (2013). Automated progress control using laser scanning technology. *Automation in Construction* 36: 108-116.
- Zhang, C., A. Hammad and H. Bahnassi (2009). Collaborative multi-agent systems for construction equipment based on real-time field data capturing. *Journal of Information Technology in Construction (ITcon)* 14(16): 204-228.
- Zhang, H. and F. Xing (2010). Fuzzy-multi-objective particle swarm optimization for time–cost–quality tradeoff in construction. *Automation in Construction* 19(8): 1067-1075.
- Zhang, S., F. Boukamp and J. Teizer (2015). Ontology-based semantic modeling of construction safety knowledge: Towards automated safety planning for job hazard analysis (JHA). *Automation in Construction* 52: 29-41.



Zhou, J., P. E. D. Love, X. Wang, K. L. Teo and Z. Irani (2013). A review of methods and algorithms for optimizing construction scheduling. *Journal of the Operational Research Society* 64(8): 1091-1105.

Zoraghi, N., Shahsavar, A., Abbasi, B., & Van Peteghem, V. (2017). Multi-mode resource-constrained project scheduling problem with material ordering under bonus–penalty policies. *Top*, 25(1), 49-79.