

©2008 IEEE. Personal use of this material is permitted. However, permission to reprint/republish this material for advertising or promotional purposes or for creating new collective works for resale or redistribution to servers or lists, or to reuse any copyrighted component of this work in other works must be obtained from the IEEE.

Adaptive Array Beam Forming Using a Combined RLS-LMS Algorithm

Jalal Abdulsayed Srar and Kah-Seng Chung

Department of Electrical and Computer Engineering, Curtin University of Technology, Perth, WA
jalal.srar@postgrad.curtin.edu.au, and k.chung@curtin.edu.au

Abstract—A new adaptive algorithm, called RLMS, which combines the use of Recursive Least Square (RLS) and Least Mean Square (LMS), is proposed for array beam forming. The convergence of the RLMS algorithm is analyzed, in terms of mean square error, in the presence of additive white Gaussian noise. Computer simulation results show that the convergence performance of RLMS is superior to either RLS or LMS operating on its own. Furthermore, the convergence of RLMS is quite insensitive to changes in either signal-to-noise ratio, or the initial value of the input correlation matrix for the RLS section, or the step size adopted for the LMS section.

Keywords—RLS algorithm, LMS algorithm, RLMS algorithm, array processing, adaptive array beam forming.

I. INTRODUCTION

In modern wireless communication systems, antenna arrays are used to enhance channel capacity through interference reduction. This is done by directing the transmit signal to the target coverage sector with as little as possible outside it. At the same time, interferences from sources outside the look direction are suppressed in the receive mode. Often, for ease of initial setup or signal tracking, it is desirable to make the antenna array adaptive so that it could automatically adjust its beam pattern with high directivity towards the desired direction while minimizing any sidelobe.

The application of least mean square (LMS) and recursive least square (RLS) algorithms to estimate the optimal weights of an adaptive antenna array is common. Although LMS offers simpler implementation with good tracking performance, a faster eigenvalue independent convergence can be achieved using the RLS algorithm [1-3]. However, both of these algorithms require a reference signal, which has to be highly correlated to the desired signal but uncorrelated to both interference and noise, for proper operation [4].

This paper attempts to lessen the requirement for an accurate reference signal, a hybrid algorithm, called RLMS, is proposed in this paper. It combines the use of RLS algorithm followed by an LMS algorithm in an arrangement as shown in Fig. 1. In this case, the output, y_{RLS} , estimated using the RLS algorithm is fed to an LMS section after it has been multiplied by the image of the desired signal array factor. The error signal for updating the LMS weights, e_{LMS} , is also fed back to combine with e_{RLS} to form a new error signal for updating the RLS weights. Although the use of a reference signal for d_{LMS}

and d_{RLS} is shown in Fig. 1, the reference may be replaced by y_{RLS} for d_{LMS} , and y_{RLMS} for d_{RLS} as described in Section II b.

The rest of the paper is organized as follows. Section II analyzes the convergence of RLMS; first by assuming the presence of a reference signal, and then with the reference signal being replaced by the estimated outputs, y_{RLS} and y_{RLMS} . The latter is referred to as self-referencing from hereon. Results obtained from computer simulations for an eight element array are presented in Section III. Finally, Section IV concludes the paper.

II. CONVERGENCE OF THE PROPOSED RLMS ALGORITHM

A. Analysis with external reference

The analysis described in this section follows the mathematical procedure given by Widrow et al in [5]. Also, the present analysis assumes the followings:

- (i) The propagation environment is stationary.
- (ii) The sequences of the input signal $X(j)$, the reference signal $d(j)$ and the weight vector $W(j)$ are mutually independent.
- (iii) The individual elements of the input signal vector $X(j)$ are non-correlated.

First, we consider the case when an external reference signal is used. From Fig. 1, the overall error signal for the RLMS algorithm at the j^{th} iteration is given by

$$e_{RLMS}(j) = e_{RLS}(j) - e_{LMS}(j-1) \quad (1)$$

$$\text{with } e_{LMS}(j) = d_{LMS}(j) - W_{LMS}^H(j)X_{LMS}(j)$$

$$\text{and } e_{RLS}(j) = d_{RLS}(j) - W_{RLS}^H(j)X(j)$$

where $(\cdot)^H$ denotes the Hermitian matrix of (\cdot) ; $X_{LMS} = A_d' y_{RLS} = A_d' W_{RLS}^H X$ and $A_d' = \alpha A_d$ with $\alpha > 0$.

Now, W_{LMS} and W_{RLS} are the weight vectors for the LMS and RLS algorithms, respectively. These weights are updated according to [2],

$$W_{LMS}(j+1) = W_{LMS}(j) + \mu X_{LMS}(j) e_{LMS}(j) \quad 0 < \mu < \mu_0 \quad (2)$$

where μ is the step size; μ_0 is a positive number that depends on the input signal statistics, and

$$W_{RLS}(j+1) = W_{RLS}(j) + \mu P(j+1) X(j) e_{RLS}(j) \quad 0 < \mu < 1 \quad (3)$$

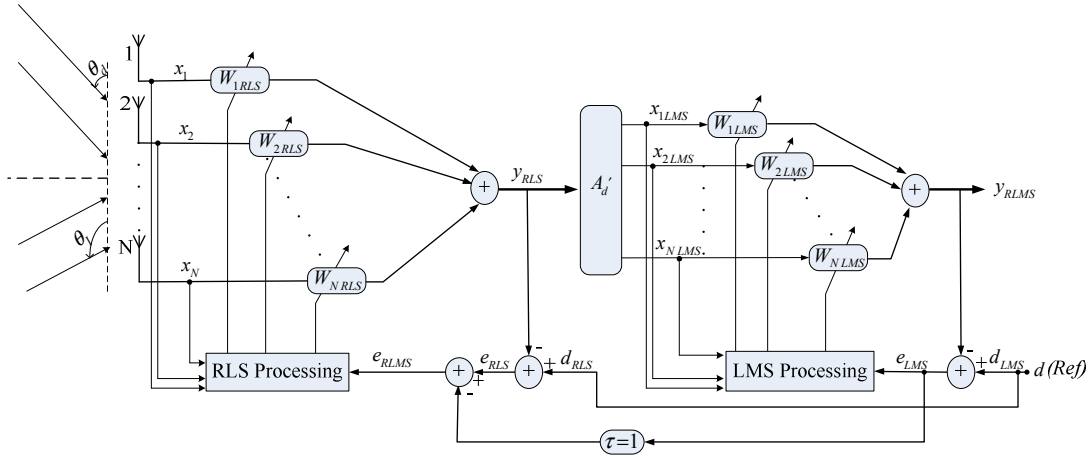

Figure 1. The proposed RLMS algorithm in the presence of an external reference signal

where $\mathbf{P}(j)$ is an arbitrary symmetric positive definite matrix given by

$$\mathbf{P}(j+1) = \frac{1}{1-\mu} \left[\mathbf{P}(j) - \frac{\mu \mathbf{P}(j) \mathbf{X}(j) \mathbf{X}^H(j) \mathbf{P}(j)}{1-\mu + \mu \mathbf{X}^H(j) \mathbf{P}(j) \mathbf{X}(j)} \right]$$

$\mathbf{P}(j)$ is initialized by $\delta^{-1} \mathbf{I}$, with δ being a small positive constant, and \mathbf{I} is an $N \times N$ unity matrix. N is the number of antenna elements, and $(1-\mu) \triangleq$ the forgetting factor.

Now, the convergence of the RLMS algorithm can be studied by observing the mean-square error ξ , which is defined as the expected value of e_{RLMS}^2 such that

$$\begin{aligned} \xi &\triangleq E \left[|e_{RLMS}|^2 \right] = E \left\{ [e_{RLS}(i) - e_{LMS}(i-1)]^2 \right\} \\ &= \sum_{i=1}^j \lambda^{j-i} E \left\{ [d_{RLS}(i) - \mathbf{W}_{RLS}^H(j) \mathbf{X}(i) - e_{LMS}(i-1)]^2 \right\} \\ &= \sum_{i=1}^j \lambda^{j-i} \left\{ E \left[D^2(i) \right] - 2E \left[D(i) \mathbf{X}^H(i) \mathbf{W}_{RLS}(j) \right] \right. \\ &\quad \left. + \mathbf{W}_{RLS}^H(j) \mathbf{Q}(j) \mathbf{W}_{RLS}(j) \right\} \end{aligned} \quad (4)$$

where $D(j) = d_{RLS}(j) - e_{LMS}(j-1)$, and \mathbf{Q} is the correlation matrix of the input signals given by [6] as

$$\mathbf{Q}(j) = \sum_{i=1}^j \lambda^{j-i} \mathbf{X}(j) \mathbf{X}^H(j) \quad (5)$$

Now, the first term on the RHS of (4) can be expressed as:

$$\begin{aligned} \sum_{i=1}^j \lambda^{j-i} \left\{ E \left[D^2(i) \right] \right\} &= \sum_{i=1}^j \lambda^{j-i} \left(E \left\{ [d_{RLS}(i) - e_{LMS}(i-1)]^2 \right\} \right) \\ &= \sum_{i=1}^j \lambda^{j-i} \left\{ |d_{RLS}(i)|^2 - 2E \left[d_{RLS}(i) e_{LMS}^*(i-1) \right] + \right. \\ &\quad \left. E \left[|e_{LMS}(i-1)|^2 \right] \right\} \end{aligned} \quad (6)$$

where $|\bullet|$ signifies modulus, and $*$ represents the conjugate.

Based on the definition of \mathbf{X}_{LMS} in (1), the second term on the RHS of (6) becomes

$$\begin{aligned} &\sum_{i=1}^j \lambda^{j-i} \left\{ -2E \left[d_{RLS}(i) e_{LMS}^*(i-1) \right] \right\} = \\ &2 \sum_{i=1}^j \lambda^{j-i} \left\{ -E \left[d_{RLS}(i) d_{LMS}^*(i-1) \right] + \right. \\ &\quad \left. E \left[d_{RLS}(i) \mathbf{X}^H(i-1) \right] \mathbf{W}_{RLS}(j-1) \mathbf{A}_d^H \mathbf{W}_{LMS}(j-1) \right\} = 0 \end{aligned} \quad (7)$$

Equation (7) is true because $d_{RLS}(i)$ and $d_{LMS}(i-1)$ as well as $d_{RLS}(i)$ and $\mathbf{X}^H(i-1)$ are uncorrelated based on assumptions (i) and (ii).

Furthermore, by applying (1) to the last term on the RHS of (6), we obtain

$$\begin{aligned} \sum_{i=1}^j \lambda^{j-i} \left\{ E \left[|e_{LMS}(i-1)|^2 \right] \right\} &= \sum_{i=1}^j \lambda^{j-i} \left\{ |d_{LMS}(i-1)|^2 + \right. \\ &\quad \left. E \left[|y_{RLMS}(i-1)|^2 \right] - 2E \left[d_{LMS}^*(i-1) y_{RLMS}(i-1) \right] \right\} \end{aligned} \quad (8)$$

As $y_{RLMS} = \mathbf{W}_{RLMS}^H \mathbf{X}$; where $\mathbf{W}_{RLMS}^H = \mathbf{W}_{LMS}^H \mathbf{A}_d^H \mathbf{W}_{RLS}^H$, and $d_{LMS}(j) = d_{RLS}(j)$, we may rewrite (8) as

$$\begin{aligned} \sum_{i=1}^j \lambda^{j-i} \left\{ E \left[|e_{LMS}(i-1)|^2 \right] \right\} &= \sum_{i=1}^j \lambda^{j-i} \left\{ |d_{LMS}(i-1)|^2 \right\} - \\ &2 \mathbf{W}_{RLMS}^H(j-1) \mathbf{Z}(j-1) + \mathbf{W}_{RLMS}^H(j-1) \mathbf{Q}(j-1) \mathbf{W}_{RLMS}(j-1) \end{aligned} \quad (9)$$

where $\mathbf{Z}(j)$ corresponds to the input signal cross-correlation vector given by [6] as

$$\mathbf{Z}(j) = \sum_{i=1}^j \lambda^{j-i} \mathbf{X}(j) d^*(j) \quad (10)$$

Substituting (7) and (9) in (6), we obtain the first term on the RHS of 5, such that

$$\begin{aligned} \sum_{i=1}^j \lambda^{j-i} \left\{ E \left[D^2(i) \right] \right\} &= \sum_{i=1}^j \lambda^{j-i} \left\{ |d_{RLS}(i)|^2 + |d_{LMS}(i-1)|^2 \right\} \\ &- 2 \mathbf{W}_{RLMS}^H(j-1) \mathbf{Z}(j-1) + \mathbf{W}_{RLMS}^H(j-1) \mathbf{Q}(j-1) \mathbf{W}_{RLMS}(j-1) \end{aligned} \quad (11)$$

Now, the second term on the RHS of (4) may be written as

$$\begin{aligned} &\sum_{i=1}^j \lambda^{j-i} \left\{ -2E \left[D(i) \mathbf{X}^H(i) \mathbf{W}_{RLS}(j) \right] \right\} = \\ &-2 \mathbf{Z}^H(j) \mathbf{W}_{RLS}(j) + 2 \sum_{i=1}^j \lambda^{j-i} \left\{ E \left[e_{LMS}(i-1) \mathbf{X}^H(i) \mathbf{W}_{RLS}(j) \right] \right\} \end{aligned} \quad (12)$$

By substituting (1) in (12), and applying assumptions (ii) and (iii), we obtain

$$\sum_{i=1}^j \lambda^{j-i} \{-2E[D(i)X^H(i)W_{RLS}(j)]\} = -2Z^H(j)W_{RLS}(j) \quad (13)$$

As a result, the mean square error ξ as specified by (4) can be rewritten to include the results of (11) and (13) to become

$$\begin{aligned} \xi = \sum_{i=1}^j \lambda^{j-i} \{ & |d_{RLS}(i)|^2 + |d_{LMS}(i-1)|^2 \} + \\ & W_{RLMS}^H(j-1)Q(j-1)W_{RLMS}(j-1) - 2Z^H(j)W_{RLS}(j) + \\ & W_{RLS}^H(j)Q(j)W_{RLS}(j) - 2W_{RLMS}^H(j-1)Z(j-1) \end{aligned} \quad (14)$$

Differentiating (14) with respect to the weight vector $W_{RLS}^H(j)$ then yields the gradient vector $\nabla(\xi)$ as

$$\nabla(\xi) = -2Z(j) + 2Q(j)W_{optRLS}(j) \quad (15)$$

By equating $\nabla(\xi)$ to zero, we obtain the optimal vector weight $W_{optRLS}(j)$ given by

$$W_{optRLS}(j) = Q^{-1}(j)Z(j) \quad (16)$$

This represents the Wiener-Hopf equation in matrix form. Therefore, the minimum MSE can be obtained from (16) and (14), such that

$$\begin{aligned} \xi_{min} = \sum_{i=1}^j \lambda^{j-i} \{ & |d_{RLS}(i)|^2 + |d_{LMS}(i-1)|^2 \} - Z^H(j)W_{optRLS}(j) \\ & + W_{RLMS}^H(j-1)Z(j-1) \{-2 + A_d^H W_{LMS}(j-1)\} \end{aligned} \quad (17)$$

Based on (16) and (17), (4) becomes

$$\xi = \xi_{min} + (W_{RLS} - W_{optRLS})^H Q (W_{RLS} - W_{optRLS}) \quad (18)$$

Now, define

$$V_{RLS} \triangleq (W_{RLS} - W_{optRLS}) \quad (19)$$

so that (18) can be written as

$$\xi = \xi_{min} + V_{RLS}^H Q V_{RLS} \quad (20)$$

Differentiating (20) with respect to V_{RLS}^H will yield another form for the gradient [5], such that

$$\nabla = 2QV_{RLS} \quad (21)$$

By using the appropriate similarity transformation q for the matrix Q [5], the second term on the RHS of (20) can be written as

$$Q = q\Lambda q^{-1} = q\Lambda q^H \quad (22)$$

where Λ is the diagonal matrix of eigenvalues of Q , i.e.,

$$\Lambda = \text{diag}[E_1, E_2, \dots, E_n] \quad (23)$$

Let $V'_{RLS} \triangleq q^{-1}V_{RLS}$, then $V_{RLS} = qV'_{RLS}$ (24)

Based on (22) and (24), we can express the MSE of (20) as

$$\xi = \xi_{min} + V'_{RLS}{}^H \Lambda V'_{RLS} \quad (25)$$

For steepest descent, the weight vector is updated according to

$$W_{RLS}(j+1) = W_{RLS}(j) + \mu(-\nabla(j)) \quad (26)$$

where μ is the convergence constant that controls stability and rate of adaptation of the weight vector, and $\nabla(j)$ is the gradient at the j^{th} iteration.

We may rewrite (26) in the form of a linear homogeneous vector difference equation using the relationships of (15), (21), (22) and (24) to give

$$V'_{RLS}(j+1) - (I - 2\mu\Lambda)V'_{RLS}(j) = 0 \quad (27)$$

According to [7], a possible solution of (27) is

$$V'_{RLS}(j) = (I - 2\mu\Lambda)^j V'_{RLS_0} \quad (28)$$

where V'_{RLS_0} is the initial value given by

$$V'_{RLS_0} = W'_{RLS_0} - W'_{optRLS} \quad (29)$$

From (25), the MSE at the j^{th} iteration is

$$\xi(j) = \xi_{min} + V'_{RLS}{}^H(j)\Lambda V'_{RLS}(j) \quad (30)$$

Replace $V'_{RLS}(j)$ from (28) in (30), and assume there is no noise, then

$$\xi(j) = \xi_{min} + V'_{RLS_0}{}^H (I - 2\mu Q)^j Q (I - 2\mu Q)^j V'_{RLS_0} \quad (31)$$

As the adaptation progresses, it is shown in [5, 7] that

$$\lim_{j \rightarrow \infty} (I - 2\mu Q)^j = \lim_{j \rightarrow \infty} q(I - 2\mu\Lambda)^j q^{-1} = 0 \quad (32)$$

This suggests the adaptive process will finally converge to

$$\lim_{j \rightarrow \infty} \xi(j) = \xi_{min} \quad (33)$$

B. Analysis of the self-referencing scheme

Consider the case when no external reference is used. Instead, Fig. 1 is modified such that the reference signals are

$$d_{RLS}(j) = y_{RLMS}(j-1) \text{ and } d_{LMS}(j) = y_{RLS}(j) \quad (34)$$

With these changes and observing that $e_{LMS} = d_{LMS} - y_{RLMS}$, then we can redefine $D(j)$ in [3] as

$$\begin{aligned} D(j) &= 2y_{RLMS}(j-1) - y_{RLS}(j-1) \\ &= d(j) \end{aligned} \quad (35)$$

Next, we reanalyze the MSE expression (4) based on this new $d(j)$ to yield

$$\begin{aligned} \xi = \sum_{i=1}^j \lambda^{j-i} \{ & E[d^2(i)] \} - 2Z^H(j)W_{RLS}(j) + \\ & W_{RLS}^H(j)Q(j)W_{RLS}(j) \end{aligned} \quad (36)$$

It can be shown that by differentiating (36) with respect to the weight vector $W_{RLS}^H(j)$ and then equating it to zero, the same expression of (16) for the optimal weights is obtained. Also, the minimum MSE can be obtained based on (16) and (36), such that

$$\xi_{\min} = \sum_{i=1}^j \lambda^{j-i} \{ |d(i)|^2 \} - \mathbf{Z}^H(j) \mathbf{W}_{optRLS}(j) \quad (37)$$

From (36) and (37), it is possible to obtain the same MSE expression as given by (18). Finally, by following the same analyzing steps from (19) to (31), we obtain the same results as indicated by (32) and (33), suggesting convergence of the RLMS algorithm using the internally generated signals as reference signals for the RLS and LMS sections.

III. SIMULATION RESULTS

The performance of the proposed RLMS algorithm has been studied by means of MATLAB simulation. For comparison purposes, results for LMS and RLS algorithms have also been obtained. For the simulations, the following parameters are used:

- A linear array consisting of 8 point elements
- A BPSK signal arriving at an angle of 0°
- The channel is AWGN with no other interference present
- All weight vectors are initially set zero.

A. Performance with external reference

First, the performances of the RLMS, RLS and LMS schemes have been studied in the presence of an external reference signal. The convergence performances of these schemes are compared based on the ensemble average square error (\bar{e}^2) obtained from 100 individual simulation runs. The results obtained with different values of SNR, δ and μ are presented.

Fig. 2 shows the convergence behaviour of the RLS and RLMS algorithms with $\delta = 0.05$, $\mu = 0.075$ and input signal-to-noise ratio, SNR = 5, 10 and 15 dB. It is observed that both algorithms achieve similar convergence speed but the RLMS scheme has lower error floor. The difference in the error floor becomes even more obvious at a lower SNR. As expected, the steady state errors for the RLS algorithm become smaller for a larger SNR. On the other hand, the RLMS scheme converges to almost the same error floor for all the three SNRs. The influence of the step size μ on the convergence performance of LMS and RLMS has been investigated for $\delta = 0.05$ and SNR = 10 dB. The results obtained with $\mu = 0.001, 0.01$ and 0.1 are shown in Fig. 3.

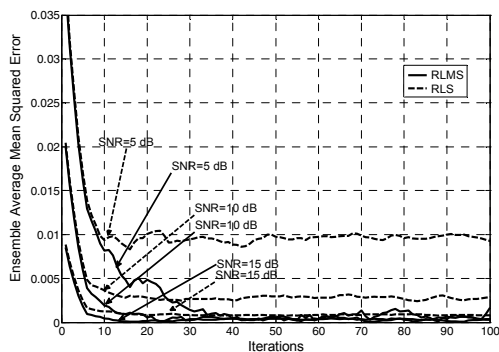

Figure 2. The convergence of RLS and RLMS with $\delta = 0.05$ and $\mu = 0.075$ for three different values of SNR.

This shows that the convergence speed of the LMS algorithm is highly dependent on μ in such a way that the

use of a large μ will speed up convergence at the expense of a higher error floor. On the other hand, the convergence performance of the RLMS scheme is not affected by the μ values used.

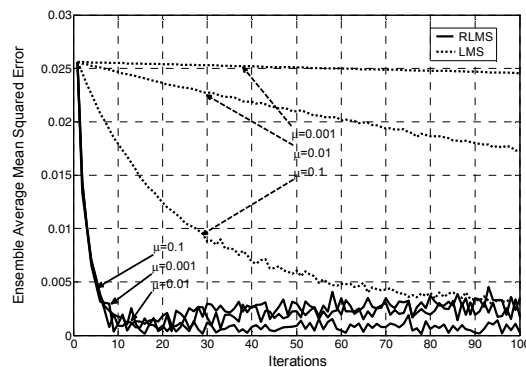

Figure 3. The convergence of LMS and RLMS schemes with $\delta = 0.05$ and SNR = 10 dB for three different values of μ .

Next, with $\mu = 0.075$ and SNR = 10 dB, the effect on the convergence of RLS and RLMS due to δ is examined. Fig. 4 shows the results obtained with $\delta = 0.05, 0.5$ and 1. As expected, the convergence of the RLS algorithm is affected by δ , but that of the RLMS scheme remains unchanged.

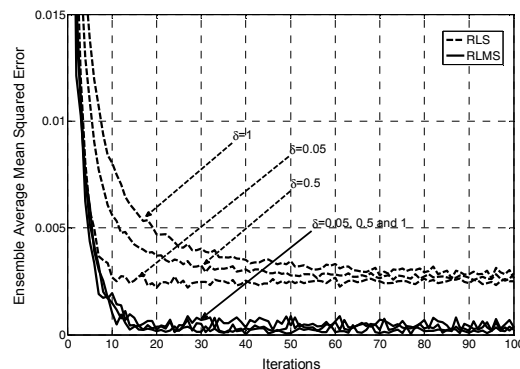

Figure 4. The convergence of RLS and RLMS schemes with $\mu = 0.075$ and SNR = 10 dB for different values of δ .

B. Performance with self-referencing

As shown in Fig. 2, the RLS algorithm converges rapidly in less than ten iterations to produce an output y_{RLS} closely resembled the input signal. This output y_{RLS} is then used as the reference signal for the next iteration of the LMS section in the RLMS algorithm. As the LMS section converges, its output y_{RLMS} can then be taken as the reference for the RLS section. This feedforward and feedback arrangement enables the provision of self-referencing in RLMS, and allows the external referencing to be terminated after an initial few iterations. The ability of the RLMS algorithm to maintain operation with the internally generated reference signals is demonstrated in Fig. 5. However, both the LMS and RLS algorithms fail to converge without the use of the correct reference signal.

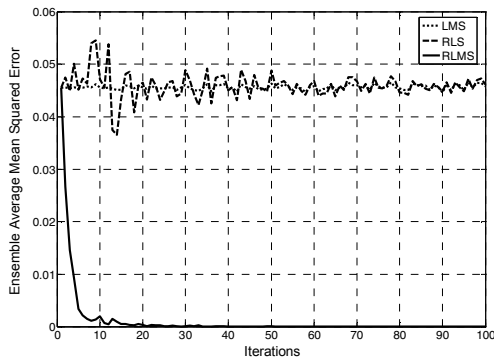

Figure 5. The convergence of RLMS with self-referencing for the case of $\mu = 0.075$, $\delta = 0.05$ and $SNR = 10\text{ dB}$. For comparison, no external reference is used for the two separate tests involving the LMS and RLS algorithms.

Fig. 6 shows the beam pattern obtained using the RLMS algorithm with self-referencing. For comparison, the beam patterns achieved with separate LMS and RLS algorithms are also shown.

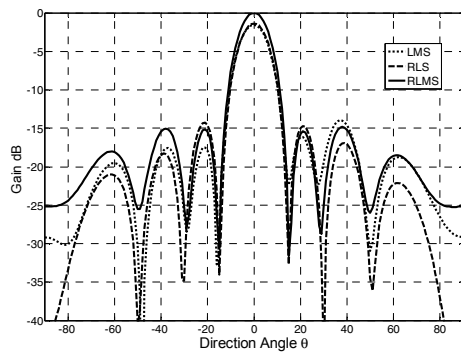

Figure 6. The beams patterns obtained with LMS, RLS and RLMS algorithms ($SNR = 10\text{ dB}$, $\delta = 0.05$, and $\mu = 0.075$).

IV. CONCLUSIONS

A new algorithm, called RLMS, which combines the use of an RLS section followed by an LMS section, is presented. The convergence of RLMS is analyzed for the case of using an external reference signal as well as one that makes use of self-referencing. The operation of the RLMS algorithm with different parameter values of μ and δ and under three different SNR conditions has been verified through Matlab simulation. The following observations are made from the results presented in Figures 2 to 6:

- Unlike the LMS and RLS algorithms, the RLMS does not always require an external reference signal for its operation. Once RLMS adapts to the desired signal using the correct reference signal during the initial few iterations, its operation can be maintained entirely through self-referencing.
- The convergence of RLMS is not sensitive to the parameter values of μ and δ used.
- The steady state MSE of RLMS is found to be less than that of the RLS and LMS on its own. Also, this MSE for RLMS is almost the same for the different SNR values considered.

- The beam pattern obtained with RLMS is similar to those with RLS and LMS.

REFERENCES

- [1] F.-B. Ueng, J.-D. Chen, and S.-H. Cheng, "Smart Antenna for Multiuser DS/CDMA Communication in Multipath Fading Channels," IEICE Transaction Communication, vol. E88, pp. 2944-2954, Jul 2005.
- [2] E. Eweda, "Comparison of RLS, LMS, and Sign Algorithms for Tracking Randomly Time-Varying Channels," IEEE Transactions on Signal Processing, vol. 42, pp. 2937-2944, Nov. 1994.
- [3] L. C. Godara, "Application of antenna arrays to mobile communications. II. Beam-forming and direction-of-arrival considerations," Proceedings of the IEEE, vol. 85, pp. 1195-1245, 1997.
- [4] S. Anderson, M. Millnert, M. Viberg, and B. Wahlberg, "An adaptive array for mobile communication systems," IEEE Transactions on Vehicular Technology, vol. 40, pp. 230-236, 1991.
- [5] B. Widrow, J. M. McCool, M. G. Larimore, and J. C. Richard Johnson, "Stationary and Nonstationary Learning Characteristics of the LMS Adaptive Filter," Aug. 1976, pp. 1151-1162.
- [6] S. Haykin, Adaptive Filter Theory, Third ed.: Prentice Hall, 1996.
- [7] B. Widrow and J. McCool, "A comparison of adaptive algorithms based on the methods of steepest descent and random search," IEEE Transactions on Antennas and Propagation, vol. 24, pp. 615-637, 1976.