

# Fuzzy Logic Approach for Power Transformer Asset Management Based on Dissolved Gas-in-Oil Analysis

Ahmed Abu-Siada\*, Sdood Hmood

Electrical and Computer Engineering Department, Curtin University, Western Australia  
a.abusiada@curtin.edu.au

Dissolved gas analysis (DGA) of transformer oil is one of the most effective power transformer condition monitoring tools which can be facilitated to determine transformer criticality ranking and hence identifying a suitable condition-based asset management decision. There are many interpretation techniques for DGA results however all current techniques rely on personnel experience more than analytical formulation. As a result, the current techniques do not necessarily lead to the same conclusion for the same oil sample. A significant number of DGA results fall outside the proposed codes of the current based-ratio methods and cannot be diagnosed by these methods. Moreover, ratio methods fail to diagnose multiple fault conditions due to the mixing up of produced gases. To overcome these limitations, this paper introduces a fuzzy logic approach to aid in standardizing DGA interpretation techniques, identify transformer critical ranking and provide a suitable asset management decision based on DGA analysis. The approach relies on integrating all existing DGA interpretation techniques into one expert prototype model. DGA results of 338 oil samples of pre-known fault condition that are collected from different transformers of different rating and different life span are used to establish the model which is developed based on the consistency of various traditional DGA interpretation techniques that are currently used by various utilities and chemical laboratories worldwide.

## 1. Introduction

Power transformers represent a critical link in any transmission or distribution network. To improve the reliability of the equipment and to avoid any catastrophic failure, effective monitoring and diagnostic techniques must be adopted. Transformer dielectric oil and paper insulation are considered as key sources to detect incipient and fast developing faults, insulation trending and generally reflects the health condition of the transformer (Abu-Siada and Islam, 2012). There are several of chemical and electrical diagnostic techniques currently used by various utilities to examine the health condition of power transformers (Arshad and Islam, 2011). Among of these techniques, dissolved gas in oil analysis (DGA) is widely used to detect power transformer incipient faults. Due to electrical and thermal stresses that operating transformer exhibits, oil and paper decomposition occurs (Arshad, 2005). Gases produced due to oil decomposition are hydrogen ( $H_2$ ), methane ( $CH_4$ ), acetylene ( $C_2H_2$ ), ethylene ( $C_2H_4$ ) and ethane ( $C_2H_6$ ). On the other hand paper decomposition produces carbon monoxide (CO) and carbon dioxide ( $CO_2$ ) (Hydroelectric, 2003). Various internal faults within a power transformer evolve particular amount of characteristic gases that can be used to determine the type and severity of fault. However, the analysis is not always straight forward as there may be more than one fault present at the same time. Partial discharge activity produces  $H_2$  and  $CH_4$  while arcing generates all gases including traceable amount of  $C_2H_2$ . DGA can be used to determine the amount and type of gases in transformer oil and hence can aid in determining the transformer failure rank (Liu et al., 2002). There are many DGA interpretation techniques such as key gas method (IEEE std, 2009), Roger ratio method (Rogers, 1978) and Duval triangle method (Duval, 2003) that have been reported in the literatures. All of these methods rely on personnel experience more than mathematical formulation. Moreover, each technique has some limitations as briefly elaborated below. Ratio Methods including Roger, IEC and Doerenenburg are only valid if a significant amount of the gas used in the ratio is present otherwise the method will not be able to identify the type of fault and will lead to invalid code. Key gas method is not widely accepted as an effective tool to evaluate the health condition of in-oil immersed transformers as it is considered very conservative and a transformer may operate safely even though its DGA analysis indicates condition 4 (imminent risk) as far as gas evolution rate is not constantly increasing. Duval triangle is an effective graphical interpretation technique. However as Duval triangle does not encompass an area for normal DGA results, the method can only be used to identify the fault type in case of faulty transformer and therefore, no indication of incipient fault can be obtained. Precise DGA interpretation is yet a challenge in the power transformer condition monitoring research area and there is no globally accepted technique for DGA interpretation. Availability of DGA data history has recently motivated researchers to develop a standard approaches for DGA interpretation based

on mathematical and artificial intelligent (AI) techniques (Singh and Verma, 2008). The application of AI in the interpretation of DGA results are mainly to overcome the drawbacks arise from the application of ratio methods that include failure to identify fault types in case of multiple fault conditions and the invalid code that some DGA results may result in. A recent study that was performed on 338 oil samples of pre-known fault condition shows that various DGA interpretation techniques are not consistent and they may lead to different interpretation for the same oil sample (Abu-Siada and Islam, 2012). To eliminate this shortcoming, results of consistency analysis in (Abu-Siada and Islam, 2012) are used to develop a fuzzy logic model that incorporates the key features of several DGA well established interpretation methods such as Roger, Doerenburg, IEC ratio methods along with key gas and Duval triangle methods. The model provides one result corresponding to a particular fault and asset management action based on all of these techniques to assure a reliable and consistent decision on the health condition of the transformer oil. The model is built to enable the user to observe the output of each individual method as will be elaborated below.

## 2. Fuzzy logic models

In this section, fuzzy logic models are developed to aid in standardizing the overall decision of various DGA interpretation techniques. Each fuzzy logic model is developed in accordance to fuzzy inference flow chart shown in Figure 1. Input variables to the model are the 7-key gases in particle per million (ppm). The output of each model is divided into 5 sets of membership functions comprising all fault conditions that operating transformers may exhibit along with a membership function for normal condition (F5) as summarized in Table 1. A membership function (F4) is added to represent the “out of code” condition that ratio methods may lead to for some DGA samples. The output membership functions for all models are shown in Figure 2.

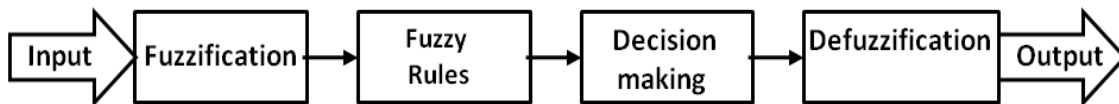

Figure 1: Fuzzy logic model flow chart

Table 1: Fault types

Method	F1 Thermal fault (Cellulose, Oil)	F2 Electrical fault (Corona)	F3 Electrical fault (Arcing)
Roger	-Thermal fault 150 °C-700 °C	-Low energy electrical discharge	- High energy discharge
IEC	-Thermal fault 150 °C-700 °C	Low energy electrical discharge	- High energy discharge
Doeren.	-Thermal decomposition	Low energy electrical discharge	- High energy discharge
Duval	-Thermal fault 150 °C-700 °C	Low energy electrical discharge	- High energy discharge
K. gas	-Over heated cellulose/ oil	Low energy electrical discharge	- High energy discharge

Table 1 is established based on Figure 3 which shows the various types of faults and the significant gases produced by each fault. Cellulosic thermal decomposition produces CO and CO<sub>2</sub> at lower temperature than that for oil decomposition and traceable amount of these gases can be found at normal operating condition. Oil thermal decomposition starts at higher temperature and at about 350 °C production of C<sub>2</sub>H<sub>4</sub> begins. At about 450 °C, H<sub>2</sub> production exceeds all other gases causing low-intensity discharges such as partial discharge and very low level intermittent arcing. At about 700 °C, more C<sub>2</sub>H<sub>2</sub> is produced causing high intensity arcing or continuing discharge proportion (IEEE std, 2009).

Set of fuzzy logic rules in the form of (IF-AND-THEN) statements relating the input variables to the output were developed based on transformer’s diagnostic and test data interpretation techniques. Each fuzzy model is built using the graphical user interface tool provided by MATLAB where each input is fuzzified into various sets of membership functions. Centre-of-gravity which is widely used in fuzzy models was used for defuzzification method where the desired output  $z_0$  is calculated as below.

$$z_0 = \frac{\int z \cdot \mu_c(z) dz}{\int \mu_c(z) dz} \quad (1)$$

where  $\mu_c(z)$  is the membership function of the output.

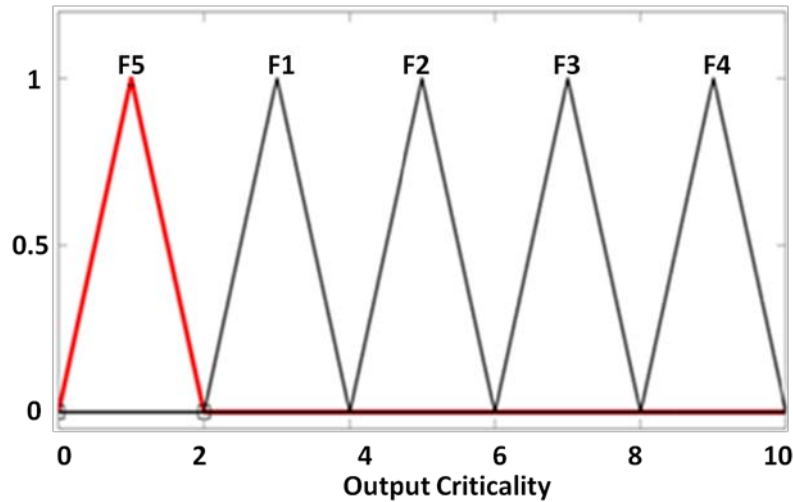

Figure 2: Fuzzy logic models output membership functions

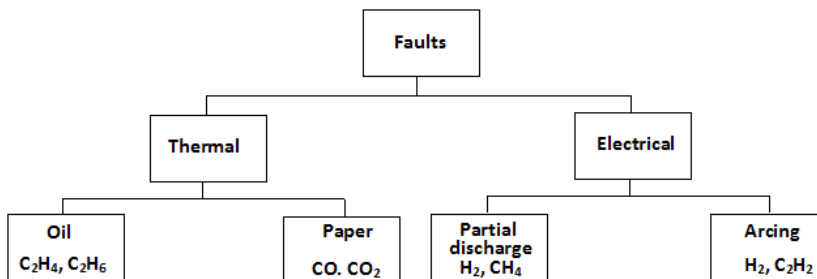

Figure 3: Types of faults and generated gases

The overall fuzzy logic model comprises 5 sub-models representing the five DGA interpretation techniques considered in this study (IEC, Roger, Doerenburg, key gas and Duval triangle). The fuzzy model for the IEC method is described in details. Same procedure was used to create the fuzzy models for the remaining methods.

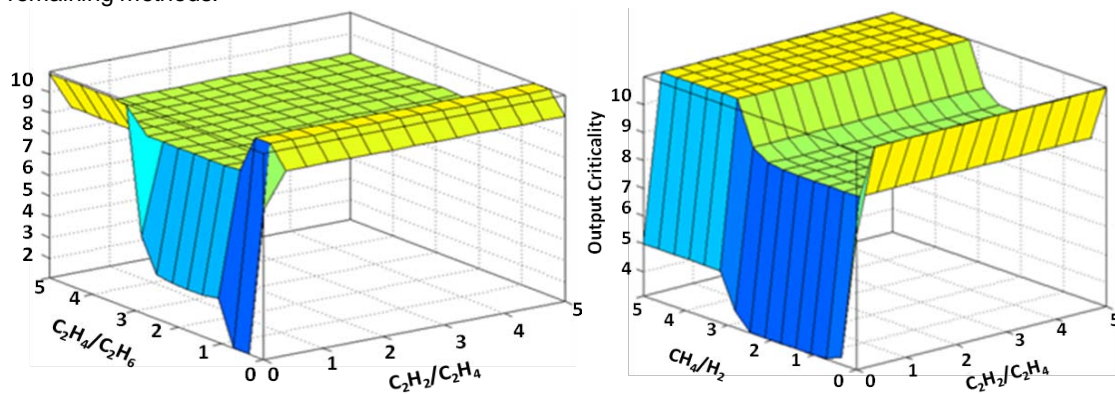

Figure 4: Surface graphs for the IEC developed rules

### 2.1 Fuzzy logic for IEC ratio method

The developed set of fuzzy rules relates the input and the output variables for IEC ratio method is shown in the 3D surface graphs (Figure 4). The model is tested with inputs,  $C_2H_2/C_2H_4$  (0.15),  $CH_4/H_2$  (2.5) and  $C_2H_4/C_2H_6$  (5) as detected in one of the transformer oil samples results using DGA. The fuzzy logic model numerical output is 7 as shown in Figure 5. This is corresponding to F3 (arcing fault) in Figure 2.

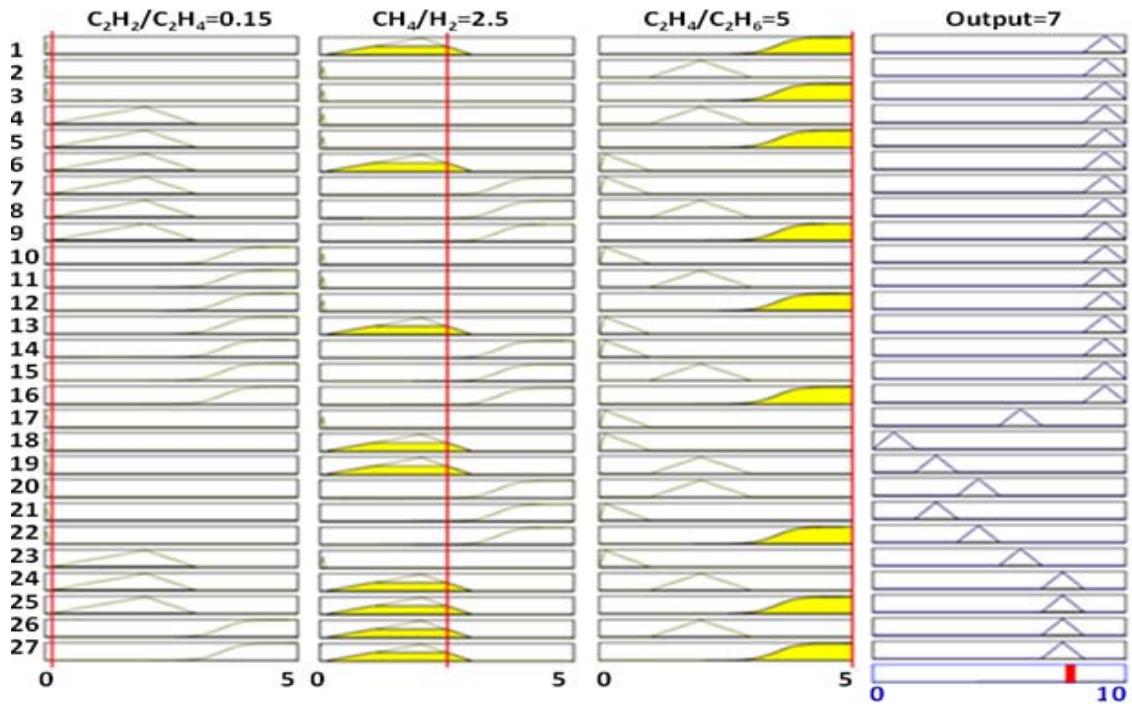

Figure 5: IEC fuzzy rules

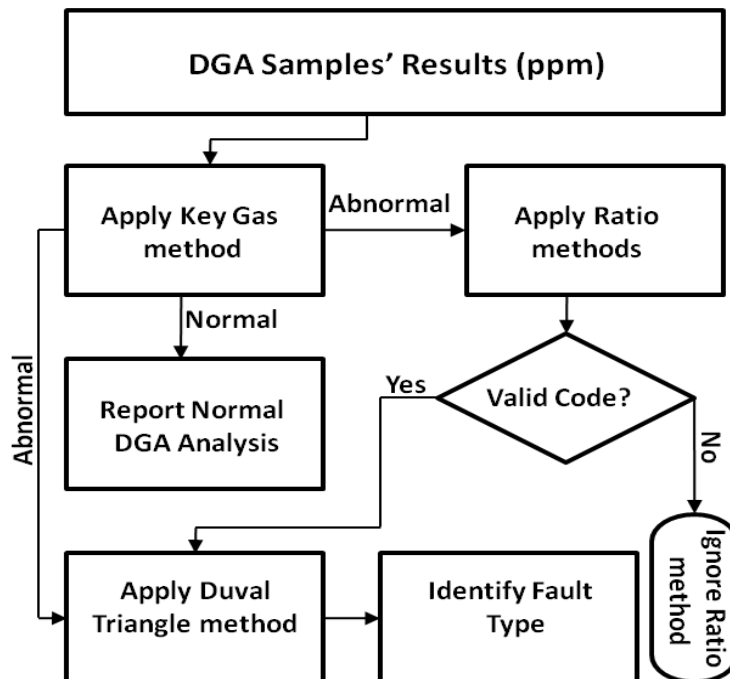

Figure 6: Flow chart of the proposed approach

### 3. Proposed approach

The new approach is based on the incorporation of different DGA techniques into one prototype software model as shown in the flow chart of Figure 6. In Figure 6, key gas method is firstly used to determine the health condition of the transformer oil sample based on its DGA results. If the key gas method results in normal condition, the model reports normal condition and no further analysis will be performed. However, if the key gas method results in abnormal condition, the oil sample will be further analysed using Duval triangle and ratio methods (IEC, Roger and Doerenburg) to accurately identify the fault type. Each individual method is used to identify the fault type and the overall decision ( $D$ ) is calculated based on the consistency level of each method according to the following equation:

$$D = \frac{\sum_{i=1}^{i=5} C_i D_i}{\sum_{i=1}^{i=5} C_i} \quad (2)$$

where  $D_i$  is the decision of each individual method weighted by its consistency level  $C_i$  as calculated in (Abu-Siada and Islam, 2012).

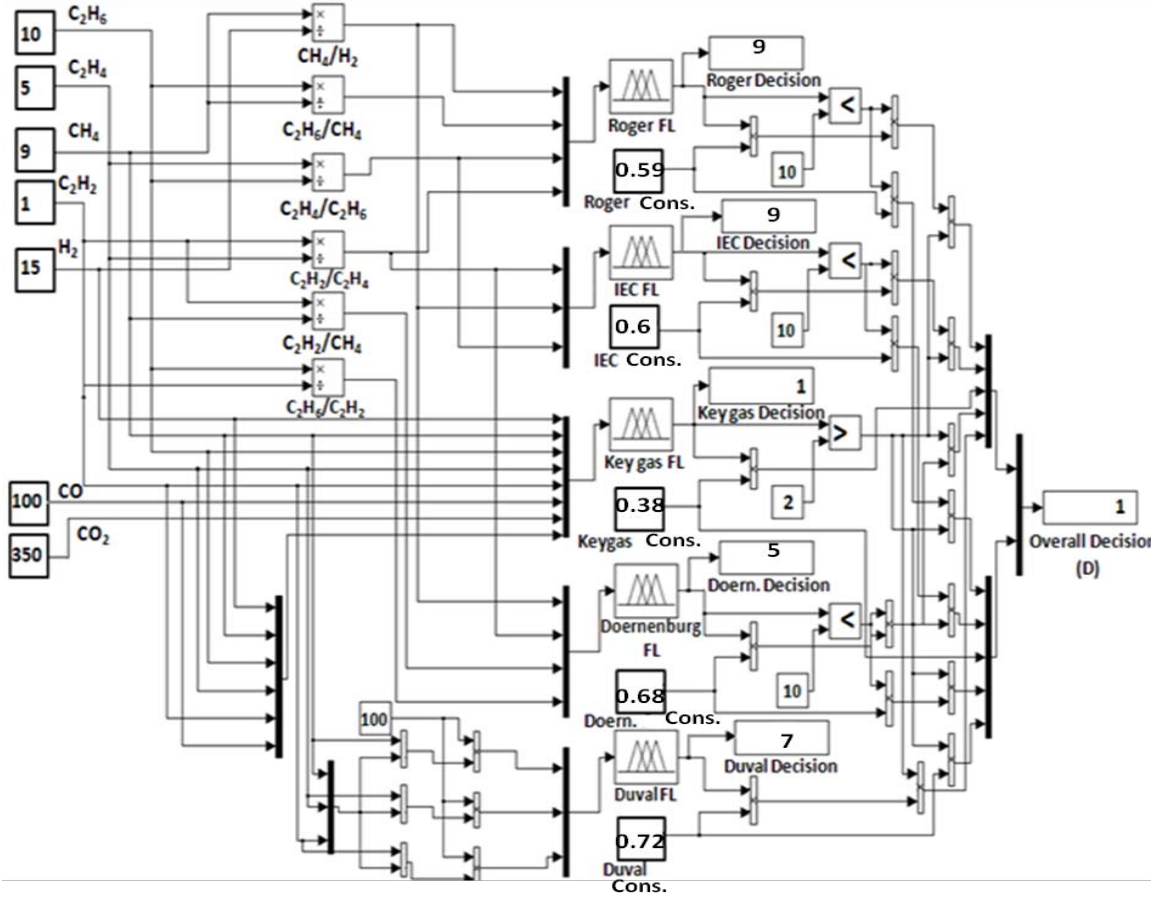

Figure 7: Proposed overall fuzzy logic model

In case any of the ratio methods provides a ratio that does not fit into the diagnostic codes, the decision value corresponding to this method is set to zero. Normal condition is only specified by key gas method while in case of faulty condition, the fault is specified by all methods. To implement the flow chart in Figure 6, the individual fuzzy logic models for various DGA interpretation techniques are integrated in one fuzzy model as shown in Figure 7. The inputs to the overall model are the 7-key gases and the output represents a numerical number that is corresponding to the failure rank of the transformer. The individual decisions for all 5 methods are weighted using the consistency level of each method and are integrated together according to (1) to provide one overall decision ( $D$ ). The model is tested for the DGA data shown in Figure 7, which shows that both Roger and IEC ratio methods provide a value greater than 8 which is corresponding to F4 in Figure 2 (out of code) and hence, their contribution to the overall decision is eliminated. Figure 7 also shows that, although Duval and Doerenburg methods result in a faulty condition, their contribution in the overall decision is also eliminated by the model as key gas method results in a normal condition and the overall decision in this case will be only specified by the key gas method according to the flow chart shown in Figure 6. The model accuracy has been assessed using other set of DGA data of pre-known fault conditions that were collected from operating transformers or research papers such as (DiGiorgio, 2005); the model showed high agreement with the collected data. Based on the model output, an asset management decision can be taken as proposed in Table 2.

Table 2: Asset management decision based on model output

Fault	Model output (D)	Fault diagnosis	Recommended decision
F5	$0 \leq D < 2$	No fault	-Continue normal operation
F1	$2 \leq D < 4$	-Cellulosic / oil decomposition -Overheated cellulose and or oil	-Exercise extreme caution -Furan analysis is recommended -Check generation rate weekly -Reduce loading below 70% -Plan outage
F2	$4 \leq D < 6$	-Corona in oil (Low intensity electrical discharge)	-Exercise extreme caution -Check generation rate weekly -Reduce loading below 60% -Plan outage
F3	$6 \leq D < 8$	-Arcing in oil (High intensity electrical discharge)	-Exercise extreme caution -Check generation rate daily -Reduce loading below 50% -Consider removal from service

#### 4. Conclusion

This paper introduces a new interpretation approach for dissolved gas analysis (DGA) of transformer oil based on the integration of the key strength of all existing interpretation techniques into one powerful expert model. Current traditional methods are not consistent and they do not necessarily lead to the same conclusion for the same oil sample. Moreover, significant number of DGA results fall outside the proposed codes of ratio-based methods. The new proposed approach relies on incorporating all traditional DGA interpretation techniques into one fuzzy logic model. All consistency-weighted decisions of individual DGA interpretation techniques are combined together to provide one overall decision on each DGA sample. This decision represents the transformer failure ranking and a proper asset management action based on the model output can be proposed.

#### References

- Abu-Siada A., Islam S., 2012, A Novel On-Line Technique to detect Power Transformer Winding Faults. IEEE Transaction on Power Delivery, 27, 849-857.
- Abu-Siada A., Islam S., 2012, A new approach to identify power transformer criticality and asset management decision based on dissolved gas-in-oil analysis. IEEE Transactions on Dielectrics and Electrical Insulation, 19, 1007-1012.
- Arshad M., Islam S., 2011, Significance of cellulose power transformer condition assessment. IEEE Transactions on Dielectrics and Electrical Insulation, 18, 1591-1598.
- Arshad M., 2005, Remnant Life Estimation Model Using Fuzzy Logic for Power Transformer Asset Management. PhD thesis, Curtin University, Perth, Australia.
- DiGiorgio J. B., 2005, Dissolved Gas Analysis of Mineral Oil Insulating Fluids. Northern Technology and Testing Report, USA, 1-21.
- Duval M., 2003, New techniques for dissolved gas-in-oil analysis. IEEE Electrical Insulation Magazine, 19, 6-15.
- Hydroelectric Research and Technical Services Group, 2003, Facilities, Instructions, Standards and Techniques; Transformer Diagnostics. 31, 1-63.
- IEEE Std C57, 2009, IEEE guide for the interpretation of gases generated in oil-immersed transformers. 104-2008 (Revision of IEEE Std C57.104-1991), C1-27.
- Liu X., Zhou F., Huang F., 2002, Research on on-line DGA using FTIR [power transformer insulation testing]. 3, 1875-1880.
- Rogers R. R., 1978, IEEE and IEC Codes to Interpret Incipient Faults in Transformers, Using Gas in Oil Analysis. IEEE Transactions on Electrical Insulation, EI-13, 349-354.
- Singh A., Verma P., 2008, A review of intelligent diagnostic methods for condition assessment of insulation system in power transformers. International Conference on Condition Monitoring and Diagnosis, 1354-1357, Beijing, China.