

The International
JOURNAL
of
INTERDISCIPLINARY
SOCIAL SCIENCES

Volume 3

Researching Tourism to the Ningaloo Reef,
Western Australia, or how the Social Sciences
can Collaborate in Researching Complex
Problems

Tod Jones and David Wood

THE INTERNATIONAL JOURNAL OF INTERDISCIPLINARY SOCIAL SCIENCES
<http://www.SocialSciences-Journal.com>

First published in 2008 in Melbourne, Australia by Common Ground Publishing Pty Ltd
www.CommonGroundPublishing.com.

© 2008 (individual papers), the author(s)
© 2008 (selection and editorial matter) Common Ground

Authors are responsible for the accuracy of citations, quotations, diagrams, tables and maps.

All rights reserved. Apart from fair use for the purposes of study, research, criticism or review as permitted under the Copyright Act (Australia), no part of this work may be reproduced without written permission from the publisher. For permissions and other inquiries, please contact [<cg-support@commongroundpublishing.com>](mailto:cg-support@commongroundpublishing.com).

ISSN: 1833-1882
Publisher Site: <http://www.SocialSciences-Journal.com>

THE INTERNATIONAL JOURNAL OF INTERDISCIPLINARY SOCIAL SCIENCES is a peer refereed journal. Full papers submitted for publication are refereed by Associate Editors through anonymous referee processes.

Typeset in Common Ground Markup Language using CGCreator multichannel typesetting system
<http://www.CommonGroundSoftware.com>.

Researching Tourism to the Ningaloo Reef, Western Australia, or how the Social Sciences can Collaborate in Researching Complex Problems

Tod Jones, Curtin University of Technology, Western Australia, AUSTRALIA

David Wood, Curtin University of Technology, Western Australia, AUSTRALIA

Abstract: There is an increasing recognition that development can bring with it complex problems, particularly when social and natural systems interact. This paper explores research methodologies that address such problems by utilising and integrating expertise from a number of different disciplines, and discusses how the social sciences can contribute. It does this by firstly analysing existing research methodologies and then through a detailed discussion of a research project that addresses sustainable tourism planning to the Ningaloo Coast, a remote tourist destination in Western Australia whose major attraction is a 300 kilometre long fringing coral reef. The paper identifies four features that are likely to become widespread within research projects that address issues of sustainable development: a common understanding of the dynamics of systems aimed at addressing complexity; an encouragement of group learning through collaboration; a pragmatic approach that aims to address problems facing managers and affected groups; and the incorporation of different disciplines as needed to address problems. The paper concludes by identifying how the social sciences can both be equipped to engage with large research projects that integrate a number of disciplines and strengthen such research approaches.

Keywords: Interdisciplinary Research, Sustainable Tourism, Adaptive Management, Organisational Learning, Ningaloo Reef

THERE IS A growing recognition of the complex issues that can accompany development, particularly when addressing problems where human and natural systems interact, such as climate change and management of environmental resources. Increasingly, a quest to understand inter-related economic, social and environmental drivers is shifting research towards interrogating their relationships as part of the assessment of specific problems, often related to management or governance (Ennals, 2004; Gibbons et al., 1994). The characteristics of this change, which we label the shift to systems-focussed research, can be discerned through the emergence and growth of three overlapping fields: adaptive management, organisational learning (which incorporates system dynamics) and transdisciplinary research. In this paper, we assess the characteristics of this emerging research paradigm through a review of the literature on these three fields. We then explore the implications of these changes for social science research, through our own experiences undertaking research on tourism to the Ningaloo Reef in Western Australia as part of a cluster of research projects. After analysing the conditions under which the research project emerged, we provide an overview of the project and the methodologies that were adapted in order to address

the research requirements within a project that can be characterised as systems-focussed.

Features of the Shift to Systems-focussed Research

Before reviewing the three fields that are informing a change in science research, it should be noted that this is neither an exhaustive list nor a complete history of these fields. Instead, we present a brief overview to illustrate the features of systems-focussed research in science research. While each of the fields can trace their origins to earlier theories and thinkers (see, for instance, Hammond, 2002), organisational learning and adaptive management both developed quickly in the 1960s and 1970s. Organisational learning, which incorporates systems dynamics, is often linked to the works of Forrester (1961), and later Senge (1990) and Morecroft and Sterman (1994). Organisational learning evolved within assessments of organisations and engineering, and was quickly applied to other areas, perhaps best encapsulated by Forrester's book, *World Dynamics* (1971). Adaptive management emerged from ecology research with a focus on managing the interactions between human and ecological systems, most notably in the work of Holling (1978), Gunderson (1995)



and Walters (1986), and also expanded quickly into other areas.¹

Transdisciplinarity differs from organisational learning and adaptive management in that its genesis is debates over categorisation of research that utilises a variety of disciplines. Transdisciplinarity as a category of research is differentiated from disciplinary, multidisciplinary and interdisciplinary research (Gibbons et al., 1994; Wickson, Carew, & Russell, 2006). Multidisciplinary research is organised around a theme and provides a series of different disciplinary perspectives on the same problem. As such, there are a variety of separate disciplinary perspectives in a multidisciplinary research project. Transdisciplinary and interdisciplinary research both undertake shared problem formulation. Where they differ is in their methodological approach and the degree of stakeholder involvement (Thompson-Klein, 2004; Wickson et al., 2006). Interdisciplinary research utilises a common methodological framework and involves researchers from a variety of different disciplines. Transdisciplinary research uses an evolving methodology and involves both stakeholders and researchers in the definition of problems and discussions over research processes and outcomes. The term was first used by Jantsch (1972) in connection with educational reform, but has subsequently been broadened to identify a category of research, and in the process provide a critique of existing research practices, particularly in the sciences.

While transdisciplinarity incorporates many elements of the other two fields, many researchers in adaptive management and learning organisations would not identify themselves as contributing to transdisciplinarity. Hence it is more accurate to identify common features rather than discuss an integration of the three fields. Additionally, it should be noted that other approaches have emerged with similar features, so the three fields analysed should not be taken as an exhaustive list. Instead, they are used to illustrate research trends. As such, the term 'systems-focussed research' identifies a set of characteristics common to these fields. It has been chosen due to a shared focus on problem formulation through understanding systems, which we explore further below.

A large part of the reason why these three approaches are becoming more prevalent is their considered and deliberate engagement with complex issues and focus on improving management outcomes. However, broader changes in research governance cannot be ignored. Barry, Born and Weszkalnys (2008) locate the push for 'interdisciplinarity', which grew out of a similar critique of existing research paradigms as transdisciplinarity, in two areas: a push for greater accountability in research to industry and

government; and the criticism that disciplinary boundaries stifle innovation and cannot deal with complex systems. While we agree with Barry, Born and Weszkalnys that these are generalisations that do not necessarily apply to all disciplines, they are common reasons given for the need for new approaches to research that are not limited by disciplinary boundaries (see, for instance, Lawrence & Despres, 2004 on transdisciplinarity). These critiques of existing research approaches link the rise of transdisciplinarity to changes in research governance that focuses on outputs, in particular contributions to management and industry. As we shall see below, these are defining features of adaptive management and organisational learning.

The three fields of organisational learning, adaptive management and transdisciplinary research share four common features. The first feature is a focus on understanding the dynamics of systems, perhaps best captured by Senge's (1990) term 'systems thinking'. This is also encapsulated by adaptive management's critique of current environmental management: rather than stabilising one or more features of an ecological or economic system, management should seek to understand and manage systemic change (Holling & Meffe, 1996). The three fields have evolved common practices of studying and analysing systems, such as understanding stability, disturbance, and tipping points where systems can suddenly flip into an entirely different mode of behaviour (Hadorn, Bradley, Pohl, Rist, & Wiesmann, 2006; Holling, 1978; Senge, 1990). A common focus on studying and understanding complexity is linked to two common research areas: environmental and sustainability research (Holling & Gunderson, 2002; van den Belt, 2004; Wickson et al., 2006). All three fields also make use of modelling to understand and represent systems and communicate solutions.

The second common feature is a focus on working with a wide variety of groups, most prominently government and industry, through the use of techniques that encourage learning through participation. Organisational learning has evolved around establishing the conditions under which members of a group can seek a new engagement with a shared task or problem in order to empower individuals, improve performance and better understand the task or problem (Senge, 1990). Similarly, adaptive management has criticised top-down natural resource management due to the way it aims to 'control' an ecosystem through maintaining a small set of characteristics (Holling & Meffe, 1996). Hence there is an emphasis on involving and communicating research to local researchers and managers (Holling, 1978), alongside management techniques that address uncertainty through monitoring, assessing and adapting in order

¹ Holling (1978) covers a range of different areas, including a study of tourism in Obergurgl, Austria.

to evolve the best possible outcomes (Norton, 2005). The emphasis on capacity building has been picked up by transdisciplinarity, including an emphasis on involving a wide variety of stakeholders in defining problems and ‘the criteria, objectives and resources used to analyse and resolve them’ (see also Hadorn et al., 2006; Thompson-Klein, 2004). This engagement is a key difference to multidisciplinary and interdisciplinary research methodologies.

The third feature is a pragmatic approach that aims to address problems facing managers and affected groups. Adaptive management’s basis in finding solutions for the issues that arise when social and natural systems interact and organisational learning’s foundation in improving management lend themselves to this characterisation. Organisational learning’s focus on solving problems is encapsulated by the trope, ‘model a problem, not a system’. Transdisciplinarity has emphasised pragmatism, often combining it with a critique of ‘pure’ research. Funtowicz, Ravetz and O’Connor, in assessing the use of science in sustainable development, provide a statement that encapsulates the aspirations of transdisciplinarity:

The objective of scientific endeavour in this new context may well be to enhance the process of the social resolution of the problem, including participation and mutual learning among stakeholders, rather than a definitive ‘solution’ or technological implementation. This is an important change in the relation between the problem identification and the prospects of science-based solutions. (1998)

The final feature is an incorporation of different disciplines as needed to resolve problems. Although this feature is common, there are differences between the three fields. Transdisciplinarity has been careful to characterise its approach to methods as ‘evolving’ in order to build on its critique of disciplinary boundaries. For instance, Wickson et al write that transdisciplinarity aims for an ‘evolving, dynamic, or responsive methodology that is iterative and an ongoing part of the research process’ (2006, p. 1049).² Adaptive management emphasised a workshop process and a problem focus where experts work is integrated through the development of a model, rather than stressing the presence or absence of disciplinary boundaries (Holling, 1978). Organisational learning is similar to adaptive management, with a greater emphasis on the expertise coming from the stakeholders involved in order to address their problems (Senge, 1990). Despite these differences,

all the fields share a strong emphasis on understanding and integrating multiple perspectives.

These four features have already been used to call for changes in existing research practices. In the field of tourism research, Farrell and Twining-Ward use revised ecosystem ecology (which is closely related to adaptive management) and organisational learning to call for tourism research to adopt methodologies that can address complex adaptive systems and contribute to sustainable transitions (2005). In a *Futures* issue on the future of social science, Costanza uses these broad features, and more detailed reflection on scales and understanding systemic change, to provide a vision of the ‘reintegration’ of the ‘study of humans and the rest of nature’ (Costanza, 2003). It is likely that the characteristics identified will increasingly be used as a critique of existing methodologies and as the basis for large projects that seek to integrate a range of disciplines, such as the Ningaloo Collaboration Cluster.

The Changing Features of Research: The Ningaloo Destination Modelling Project

The Ningaloo Destination Modelling project provides an example of how changing research priorities are shaping research. The object of the Ningaloo Destination Model (NDM) project is to develop a tourism scenario planning tool, in the form of a simulated model of the tourism system, whereby groups, agencies and community members could collaboratively test the possible impacts of tourism management decisions, in particular related to tourism planning, over varying time periods. In order to understand the institutional arrangement that brought about this project, it is necessary to briefly review the background and structure of the project. The NDM project is one of six research projects within the Ningaloo Collaboration Cluster, which is part of the Commonwealth Scientific and Industrial Research Organisation’s (CSIRO) Wealth from Oceans Flagship initiative.

The CSIRO, Australia’s national science research agency, began the National Flagships Initiatives in 2003. The National Flagship Initiative was primarily driven by the desire to encourage cooperation across different disciplinary groups within the CSIRO and with other institutions’ national research priorities (each Flagship addresses a national research priority) (CSIRO, 2007). Encouraging collaboration and an increasing focus on partnerships with industries and communities to increase research uptake was also viewed as a way to demonstrate increasing science capacity and relevance to national research funding

² One of the reasons for the careful characterisation of methodological development as dynamic and evolving is the emphasis on avoiding disciplinary boundaries and distinguishing transdisciplinary research from ‘multidisciplinary research’ as the later uses methodologies from different disciplines (Lawrence & Despres, 2004; Wickson et al., 2006).

bodies. A group within CSIRO that had experience undertaking research that engaged with communities, industry and management organisations was working in Marine and Atmospheric Research. Using a framework called Management Strategy Evaluation (MSE), which seeks to capture the entire adaptive management cycle in the simulation model. This group worked with fisheries management panels to evaluate different management regimes through the use of simulated models (Sainsbury, Punt, & Smith, 2000).

The Collaboration Clusters are an initiative to involve Australian universities in large collaborative research projects on national research priorities, with the first two rounds of clusters having a value of \$AU70 million in funding and in-kind contributions (CSIRO, 2007). The Ningaloo Collaboration Cluster partners are the CSIRO, various Australian universities, and the Sustainable Tourism Cooperative Research Centre (STCRC). The aim of this partnership is to develop systems to explore alternative scenarios for managing and developing this region without compromising the integrity of its ecosystem. The most widely admired element of the ecosystem is the Ningaloo Reef, one of Western Australia's most unique natural environments and a tourism attraction that makes an important contribution to local communities (Carlsen & Wood, 2004). CSIRO's Marine and Atmospheric Research group are providing the expertise for integrating the information from a number of projects into a model to assess management strategies. Our research centre, the Curtin Sustainable Tourism Centre, has undertaken a project to assess the socio-economics of tourism to the Ningaloo Coast region, which has the goal of developing a dynamic model incorporating the economic, environmental and social impacts of tourism through discussions and workshops with the tourism industry, government agencies and the local community. As such, we provide the social science expertise, with a focus on understanding the social and economic aspects in particular of natural resource management within the region. The STCRC, a national tourism research centre that is funded through contributions from partner universities and the Australian Federal Government, has previously undertaken destination modelling projects. Our project builds on this research.

The NDM project displays the four features of systems-focussed research: a focus on systems, in this case the interaction of a rural community and economy with a fringing coral reef; engagement with managers, industry and the local community to build understandings of the effects of management decisions and ultimately increase their management capacity; a focus on current management issues and

finding solutions; and the incorporation of different disciplines to assess different aspects of the natural and human systems. In the next section we explore in more depth the tools and methods used to undertake this research, before concluding with an assessment of the possibilities and potentials for social science in engaging with systems-focussed research.

The Ningaloo Experience: Having a Systems Focus in the Social Sciences

Building the NDM has required consideration of a broad array of variables that both affect and are affected by management decisions.³ For instance, the model requires an understanding of the demographics, characteristics and motivations of tourists, plus an understanding of how tourists would behave under different conditions. Additionally, economic impacts (spending patterns), social impacts (such as crowding, housing) and environmental impacts (due to changing activity patterns along the coast) all need to be considered. Researchers from a number of disciplines provided input in order to assess different aspects of the tourism system. These included planners, tourism economists, an environmental engineer, a geologist, social scientists with expertise in community impacts, and environmental scientists who could assess the impacts of coastal camping and activities. Additionally, a requirement of the project was engagement with other groups to exchange data and to input into the modelling being undertaken by the Marine and Atmospheric Research group. Given the breadth of research needed to assess tourism planning decisions and the engagement with other projects, it is a good case study of how social science has engaged with systems-focussed research.

The primary requirement of the NDM project is a need to formulate the characteristics and associated issues of tourism as aspects of a system. This involves two related changes. First, tourism itself needed to be broadly formulated as a system, incorporating linkages between visitation, economic, social and ecological systems. Systems are at the heart of much social science (Richardson, 1991), including much tourism research that measures or assesses different features of a tourism system. Where systems-focussed research differs is that it encourages research to focus more directly on the system itself and the relationships between variables, rather than one or more particular features. For instance, systems tend to have a degree of variance, such as tourism numbers or the number of whale shark occurrences on the Ningaloo Coast. As an example, while it is important to know the number of tourists or whale sharks, research also should address limitations on the system (accommodation, transport for tourists,

³ We are using Vensim software to model the tourism system.

food for whale sharks), the effects of shocks to the system (increase in petrol prices, increased fishing of whale sharks in Indonesia), what to monitor to identify important changes (travel plans, attitudes to petrol prices, and the size and age of whale sharks), and interactions between systems (if whale shark occurrences decline, reduced numbers of international visitors outside the peak season). Most importantly, the research focus broadens from assessing one aspect of the system at a particular time to monitoring variance and assessing the relationships with other variables and systems. These ideas are not new and have already been suggested as a method of furthering tourism research (Farrell & Twining-Ward, 2005).

Second, researchers in the NDM project needed to become familiar with the terminology and concepts applied to systems, most notably in adaptive

management and organisational learning. The language of systems reflects key concepts, illustrated here by an example. Feedback loops are an important concept. This occurs where one part of a system affects another part, which in turn feeds back to either limit (negative feedback) or increase (positive feedback) the first variable in the system. For instance, visitors from a nearby caravan park could go to a beach, have their expectations of a wonderful day met, and then go and tell other visitors who in turn go to the beach and stay in the caravan park (positive feedback – see figure 1(a)). However, visitor numbers could lead to a crowded beach, which then deters other visitors from staying in the caravan park (negative feedback – see figure 1(b)). This is called self-limiting system as the number of visitors find an equilibrium.

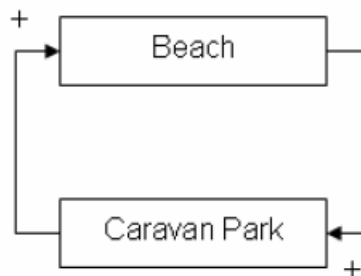

Figure 1(a): Positive Feedback

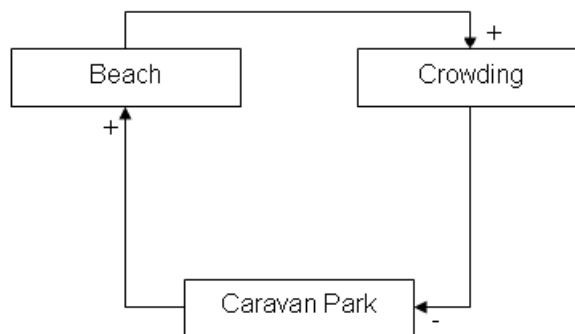

Figure 1(b): Negative Feedback

Another important concept is a critical point (also called a tipping point), where a system can change from one mode of behaviour to a completely different kind of behaviour. To return to the beach example, say a large hotel is built nearby and hotel visitors start coming to the beach in large numbers, visitors

from the caravan park dislike the changed character of the beach and move to another location (see figure 1(c)). This is known as a critical point because the behaviour of the system changes once the new accommodation has been included.

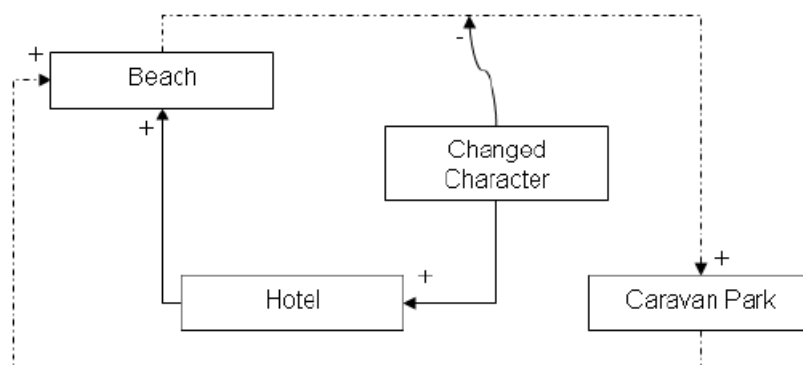

Figure 1(c): A Critical Change in a Tourism System. The Original System Weakens due to the Introduction of the Hotel

While these are simple examples, the importance of the concepts lies in the way that they can be applied within different disciplines to assist communication and knowledge transfer. These concepts and language also help focus research on important relationships within the system, and assist research integration. Finally, all of the above assists model development. An important aspect of much of this research is the development of models to assist in understanding and managing complex adaptive systems. Walters considers it an essential part of assessing adaptive management (1986).

The NDM project has also highlighted the need for skills in engaging with a broad range of industry and community groups and public agencies. An important element of the NDM project was building relationships with stakeholders and, most importantly for the development of the project, running a series of public workshops. Stakeholder involvement is crucial to the NDM project as they will be the users of the NDM model and therefore need to both input into the model and trust its output. Furthermore, an important part of the process is mutual learning about how different groups and individuals understand tourism and its impacts. The workshops served two primary purposes. First, they provided an understanding of the tourism system by integrating different perspectives on the system. Second, they were used to develop four scenarios that summarised four different futures for tourism and identified the different planning mechanisms that could affect outcomes. These scenarios are guiding model development to ensure that the finished model will be relevant to its users. The social sciences have a long history of engaging with different groups and would be well placed to understand the relationships between stakeholders, undertake qualitative research and to run workshops.

The NDM project has involved both secondary and primary data which is both quantitative and qualitative in nature. Systems-focussed research has a preference for quantitative data, due in particular

to the widespread use of mathematical models. However, qualitative data is also important for gaining a greater understanding of the complexity of relationships, particularly in the social sphere involving local communities and tourists, and can also be used to input into models. It is also important to have an understanding of working with different scales, both spatially and temporally. Feedback loops are useful here as they are quite often delayed and their effects only become apparent in the longer term. Spatial distribution is also important as the effects at a set of locations cannot always be equated with an aggregated set of data (Costanza, 2003). Secondary data is being collected from a variety of different sources and other research projects. Systems-focussed research is data hungry, so it is important to focus on understanding key relationships and to make use of existing data resources.

Finally, communication of research results in the NDM project is crucial to ensuring successful project outcomes. The NDM will be complicated and difficult to understand. As such, it is important the output is simplified so that users understand the key relationships and can make decisions based on its results. This is particularly important as the aim of the model is to provide a more in-depth understanding of tourism, in particular the impacts of tourism planning decisions. Communication needs to be clear and will use visual aids to provide easy to understand representations of impacts (such as graphs, images and descriptions). An idea that received much support in the workshops was for an annual Ningaloo Tourism Futures Forum, where anybody concerned about tourism could send in potential events or decisions that would impact tourism, which would be then run through the model. The results would be presented in a forum in the region, after which there would be a discussion regarding how to proceed. Research output is therefore geared towards impacting on the behaviour and decisions of local groups and managers.

Conclusion

Research into systems is not new. Social science disciplines have been studying and conceptualising systems since their inceptions (Richardson, 1991) and organisation learning and adaptive management have their roots back in the 1960s. However, there is now an increase in research that addresses the conundrums of development, in particular where human and natural systems interact. Related critiques of existing disciplinary boundaries and moves to integrate social, economic and environmental impacts into assessments of complex problems are creating an environment where systems-focussed research will become increasingly prominent. The four features that are likely to become widespread within research projects that address such issues are: a common understanding of the dynamics of systems aimed at addressing complexity; an encouragement of group learning through collaboration; a pragmatic approach that aims to address problems facing managers and affected groups; and the incorporation of different disciplines as needed to address problems. Through the NDM project, it is possible to identify characteristics that will assist the social sciences to engage as a collaborator in this research approach. There will be increasing opportunities for engagement due to the recognition of the importance of social systems in complex problems. Social science disciplines will both need to be equipped with new methods of engagement and be aware of where they can strengthen this research approach.

An important first step for social science disciplines would be to become familiar with the language and concepts of systems analysis. The capacity to express disciplinary knowledge in the terminology and forms used for systems would be an addition to social science disciplines that would enable a broader engagement with other fields as part of a research push to understand complex problems. With regards to data collection, quantitative data is pre-

ferred at present, although qualitative data can also be used. However, there is a need to develop techniques that integrate qualitative data more effectively within models. An important aspect of this problem is that most modellers are familiar with quantitative, rather than qualitative, data. This is an issue that would be addressed through greater social science engagement. An area where social science disciplines are equipped to strengthen systems-focussed research is engagement with a broad range of industry, government and community groups. Effective engagement is integral to systems-focussed research, and many social science disciplines can contribute to understanding stakeholder relations and effective engagement, particularly in a workshop setting. Finally, research output will shift towards collaborative tools to inform and assist management decisions. Input from the social sciences can both ensure that social issues and impacts are being adequately addressed in these tools and also assess their appropriateness and effectiveness. If the products of system-focussed research are not culturally appropriate or overly complex for eventual users, the quality of the research behind them will be of little consequence. Systems-focussed research is an avenue for addressing the problems of development in the Twenty First century. Engaging with this research and understanding where social science disciplines can contribute are important steps towards ensuring both that social impacts are adequately addressed and that social science strengthens and contributes to important research projects.

Acknowledgements

The authors would like to thank Beth Fulton and Karin Schianetz for their comments on this paper. We would also like to acknowledge the support provided by the CSIRO's Wealth from Oceans Flagship and the Sustainable Tourism Cooperative Research Centre that made this research possible.

References

- Barry, A., Born, G., & Weszkalnys, G. Logics of interdisciplinarity. *Economy and Society* 37(1) (2008): 20-49.
- Carlsen, J., & Wood, D. *Assessment of the Economic Value of Recreation and Tourism in Western Australia's National Parks, Marine Parks and Forests*, Gold Coast: Collaborative Research Centre for Sustainable Tourism, 2004.
- Costanza, R. A vision of the future of science: reintegrating the study of humans and the rest of nature. *Futures* 35(6) (2003): 651-671.
- CSIRO. *National Research Flagships: Addressing National Challenges*, Melbourne: CSIRO, 2007.
- Ennals, R. Europe as a knowledge society: Integrating universities, corporations, and government. *Systemic Practice and Action Research*. 17(3) (2004): 237-248.
- Farrell, B., & Twining-Ward, L. Seven steps towards sustainability: Tourism in the context of new knowledge. *Journal of Sustainable Tourism* 13(2) (2005): 109-122.
- Forrester, J. W.. *Industrial Dynamics*. Cambridge, Mass.: MIT Press, 1961.
- Forrester, J. W. *World Dynamics*. Cambridge, Mass.: Wright-Allen Press, 1971.
- Funcionowicz, S. O., Ravetz, J. R., & O'Connor, M. Challenges in the use of science for sustainable development. *International Journal for Sustainable Development* 1, (1998):99-107.

- Gibbons, M., Limoges, C., Nowotny, H., Schwartzman, S., Scott, P., & Trow, M. (1994). *The New Production of Knowledge: The New Dynamics of Science and Research in Contemporary Societies*. Stockholm: Sage.
- Gunderson, L. H., & Holling, C. S. *Barriers and Bridges to the Renewal of Ecosystems and Institutions*. New York: Columbia UP, 1995.
- Hadorn, G. H., Bradley, D., Pohl, C., Rist, S., & Wiesmann, U. Implications of transdisciplinarity for sustainability research. *Ecological Economics* 60(1) (2006): 119-128. Retrieved: Nov, from
- Hammond, D. Exploring the genealogy of systems thinking. *Systems Research and Behavioral Science*, 19(5) (2002): 429-439.
- Holling, C. S. (Ed.). *Adaptive Environmental Assessment and Management*. Oxford: International Institute for Applied Systems Research, 1978.
- Holling, C. S., & Gunderson, L. H. (Eds.). *Panarchy: Understanding Transformations in Human and Natural Systems*. Washington DC: Island Press, 2002.
- Holling, C. S., & Meffe, G. K. Command and Control and the Pathology of Natural Resource Management. *Conservation Biology* 10(2) (1996): 328-337.
- Jantsch, E. Towards interdisciplinarity and transdisciplinarity in education and innovation. In CERI (Ed.), *Interdisciplinarity: Problems of teaching and Research in Universities*. (pp. 97-121). Paris: OECD, 1972.
- Lawrence, R. J., & Despres, C. Introduction: Futures of Transdisciplinarity. *Futures* 36(4) (2004): 397-405.
- Morecroft, J. D. W., & Sterman, J. D. (Eds.). *Modeling for Learning Organizations*. Portland, OR.: Productivity Press, 1994.
- Norton, B. G. *Sustainability A Philosophy of Adaptive Ecosystem Management*. Chicago: University of Chicago Press, 2005.
- Richardson, G. P. *Feedback Thought in Social Science and Systems Theory*. Philadelphia: University of Pennsylvania Press, 1991.
- Sainsbury, K. J., Punt, A. E., & Smith, A. D. M. Design of operational management strategies for achieving fishery ecosystem objectives. *ICES Journal of Marine Science* 57 (2000): 731-741.
- Senge, P. M. *The Fifth Discipline: The Art and Practice of the Learning Organization*. New York: Currency Doubleday, 1990.
- Thompson-Klein, J. Prospects for Transdisciplinarity. *Futures* 36(4) (2004): 515-526.
- van den Belt, M. *Mediated Modeling: A Systems Dynamics Approach to Environmental Consensus Building*. Island Press: Washington, 2004.
- Walters, C. *Adaptive Management of Renewable Resources*. New York: Macmillan, 1986.
- Wickson, F., Carew, A. L., & Russell, A. W. Transdisciplinary research: characteristics, quandaries and quality. *Futures* 38(9) (2006): 1046-1059.

About the Authors

Dr. Tod Jones

Tod has undertaken research in a range of different areas including economic evaluation, wildlife tourism, natural area tourism cultural tourism and cultural policy in Indonesia. Currently, Tod's research involves combining systems dynamics with sustainable tourism planning in participatory approaches to tourism planning. This research focusses on the Ningaloo Reef, an iconic tourism destination in Western Australia's northwest and has recently become the focus of a world heritage application.

Prof. David Wood

David is Project Leader of the Ningaloo Destination Modelling project, Chair of the State's Coastal Planning and Coordination Council, Deputy Chair of the Ningaloo Sustainable Development Committee and is a member of the Western Australian Planning Commission. He is a planning practitioner, a supervisor of doctoral students and an active researcher in the areas of coastal tourism, planning and development, and community participation. David's research focus also includes economic and social valuation of tourism impacts, developed through his research in the Gascoyne area of Western Australia.



EDITORS

Mary Kalantzis, University of Illinois, Urbana-Champaign, USA.

Bill Cope, University of Illinois, Urbana-Champaign, USA.

EDITORIAL ADVISORY BOARD

Patrick Baert, Cambridge University, Cambridge, UK.

Norma Burgess, Syracuse University, Syracuse NY, USA.

Vangelis Intzidis, University of the Aegean, Rhodes.

Paul James, RMIT University, Melbourne, Australia.

José Luis Ortega Martín, Universidad de Granada, Spain.

Francisco Fernandez Palomares, Universidad de Granada, Spain.

Miguel A. Pereyra, Universidad de Granada, Spain.

Constantine D. Skordoulis, University of Athens, Athens, Greece.

Chryssi Vitsilakis-Soroniatis, University of the Aegean, Rhodes, Greece.

THE UNIVERSITY PRESS JOURNALS

International Journal of the Arts in Society

Creates a space for dialogue on innovative theories and practices in the arts, and their inter-relationships with society.

ISSN: 1833-1866

<http://www.Arts-Journal.com>

International Journal of the Book

Explores the past, present and future of books, publishing, libraries, information, literacy and learning in the information society. ISSN: 1447-9567

<http://www.Book-Journal.com>

Design Principles and Practices: An International Journal

Examines the meaning and purpose of 'design' while also speaking in grounded ways about the task of design and the use of designed artefacts and processes. ISSN: 1833-1874

<http://www.Design-Journal.com>

International Journal of Diversity in Organisations, Communities and Nations

Provides a forum for discussion and builds a body of knowledge on the forms and dynamics of difference and diversity.

ISSN: 1447-9583

<http://www.Diversity-Journal.com>

International Journal of Environmental, Cultural, Economic and Social Sustainability

Draws from the various fields and perspectives through which we can address fundamental questions of sustainability.

ISSN: 1832-2077

<http://www.Sustainability-Journal.com>

Global Studies Journal

Maps and interprets new trends and patterns in globalization. ISSN 1835-4432

<http://www.GlobalStudiesJournal.com>

International Journal of the Humanities

Discusses the role of the humanities in contemplating the future and the human, in an era otherwise dominated by scientific, technical and economic rationalisms. ISSN: 1447-9559

<http://www.Humanities-Journal.com>

International Journal of the Inclusive Museum

Addresses the key question: How can the institution of the museum become more inclusive? ISSN 1835-2014

<http://www.Museum-Journal.com>

International Journal of Interdisciplinary Social Sciences

Discusses disciplinary and interdisciplinary approaches to knowledge creation within and across the various social sciences and between the social, natural and applied sciences.

ISSN: 1833-1882

<http://www.Socialsciences-Journal.com>

International Journal of Knowledge, Culture and Change Management

Creates a space for discussion of the nature and future of organisations, in all their forms and manifestations.

ISSN: 1447-9575

<http://www.Management-Journal.com>

International Journal of Learning

Sets out to foster inquiry, invite dialogue and build a body of knowledge on the nature and future of learning.

ISSN: 1447-9540

<http://www.Learning-Journal.com>

International Journal of Technology, Knowledge and Society

Focuses on a range of critically important themes in the various fields that address the complex and subtle relationships between technology, knowledge and society. ISSN: 1832-3669

<http://www.Technology-Journal.com>

Journal of the World Universities Forum

Explores the meaning and purpose of the academy in times of striking social transformation.

ISSN 1835-2030

<http://www.Universities-Journal.com>

FOR SUBSCRIPTION INFORMATION, PLEASE CONTACT

subscriptions@commonground.com.au