

Experimental Studies of Suction-Monitored Direct Shear Apparatus on Perth Poorly Graded Sand

Yusep Muslih Purwana¹, Peerapong Jitsangiam², Hamid Nikraz² and Apiniti Jotisankasa³

¹Sebelas Maret University, Indonesia

²Curtin University, Western Australia

³Kasetsart University, Thailand

Synopsis: Perth, Western Australia is a semi arid climate area. A soil characteristic at a near surface layer is relatively dry due to the deep water table, low humidity and high rate of evaporation. Subsurface exploration carried out in this study indicated that most soils in Perth are classified as poorly graded sand and remain dry along the year. Therefore, most Perth soils are considered to be in an unsaturated condition. The aim of this study is to evaluate the unsaturated Perth soil properties. Conventional and modified direct shear apparatuses were utilized in the shear strength evaluation of the saturated and unsaturated Perth soils. Modification of the direct shear apparatus was conducted by attaching a low capacity tensiometer to the direct shear top cap to measure the matric suction of the soil samples. The results indicate that during shear, suction is relatively low for a range of saturation degree of 50 to 100% and well within the tensiometer capacity, indicating that the modified direct shear apparatus is suitable for measuring the unsaturated poorly graded Perth sand.

Keywords: direct shear, tensiometer, soil suction, unsaturated soil.

1. Introduction

Perth in Western Australia is in semi arid area. Almost along the year, the soil in this area is usually relatively dry due to deep water table, low humidity and high rate of evaporation. In such condition, unsaturated soil approach with suction measurement has absolutely to be taken into consideration for soil engineering properties consideration.

Soil suction is an important parameter in unsaturated soil mechanics. The role of this parameter is as significant as the pore water pressure of the effective stress concept in the saturated soil mechanics [1]. One of the issues associated with unsaturated soil is how to obtain shear strength parameter in unsaturated conditions. Triaxial and direct shear tests are two commonly used devices for unsaturated soil testing in practice. These tests can be carried out by modifying them with some instruments capable of measuring soil suction under unsaturated conditions. Compared to triaxial test, the direct shear test is considered simpler due to short drainage path of the specimen.

There are 2 types of unsaturated direct shear tests; suction-controlled and suction-monitored types. The first one is pioneered by Donald [2], and it is the most common type in direct shear test. The test is carried out by applying desired matric suction during the test mostly using the axis translation technique (i.e. directly controlling pore air and pore water pressure). The second one is suction-monitored type. The test is carried out by monitoring suction instead of controlling it by using attached tensiometer(s) to the shear box [e.g., 3, 4]. The tensiometer is developed by Geotechnical Engineering Research and Development Center, GERD, Kasetsart University, Thailand. Even though the capacity of tensiometer used is low (0-90 kPa), suction-controlled direct shear proposed by Jotisankasa and Mairaing [5] is suitable for material with low air entry value such as sand or residual soil. However the literature about this test is still very few and needs further study.

The shear strength of unsaturated soil can be expressed by equation:

$$\tau_{ff} = c' + (\sigma_f - u_a)_f \tan \phi' + (u_a - u_w)_f \tan \phi^b \quad (1)$$

where c' is effective cohesion, $(\sigma - u_a)_f$ is net normal stress, ϕ' is effective angle of internal friction, $(u_a - u_w)_f$ is matric suction, and ϕ^b is angle of shearing resistance due to contribution of suction [6]. Equation (1) can also be rewritten as:

$$\tau_{ff} = \tau_{sat} + \tau_{us} = [c' + (\sigma - u_a)_f \tan \phi'] + [(u_a - u_w)_f \tan \phi^b] \quad (2)$$

where τ_{sat} is shear strength under saturated condition and τ_{us} is contribution of suction towards shear strength. It is clear from the equation that shear strength of unsaturated soil consists of two parts; shear strength under saturated condition plus contribution of suction.

The study carried out by some researchers [e.g., 7, 8, 9] indicated that shear strength variation with respect to suction is non linear and is influenced by soil type. At saturated zone (from zero suction to air entry value), the value of ϕ^b is equal to ϕ' and gradually decreases when suction increases beyond the desaturation point. However, for very low range of suction the value of ϕ^b is assumed to be linear [10], and can be higher than ϕ' due to the effect of dilation as a result of complex response of unsaturated sand [11].

This paper presents the use of suction-monitor direct shear test of compacted Perth poorly graded sand in unsaturated condition. Shear strength and suction measurement was focused on specimen at optimum moisture content (OMC) \pm 3 %. At the end of the paper, soil-water characteristic curve (SWCC) test by using continuous measurement drying path is presented.

2. Suction-Monitored Direct Shear

Suction-monitored direct shear is conventional direct shear with modification by attaching tensiometer with 0-90 kPa capacity to shear box. The purpose of attaching this instrument is to measure negative pore water pressure during testing. It consists of 15 mm of 1 bar air entry ceramic disk, transparent acrylic tube, and pressure sensor, and is placed in such a way that its air entry ceramic remains good contact with the soil specimen during testing. Usually, the easiest way is to attach this instrument on the top cap of shear box as shown in Figure 1.

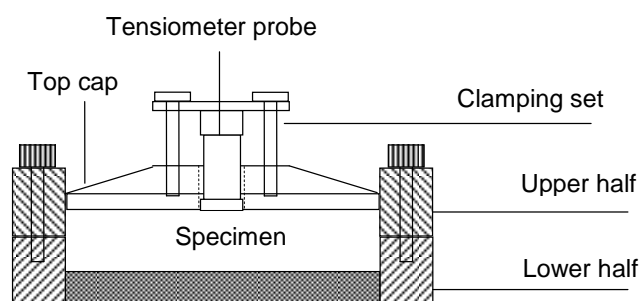

Figure 1. Schematic cross section of modified direct shear box

Tensiometer is connected to data logger or readout unit so that suction measurement together with loading and displacement can be recorded continuously during the test. Before testing, calibration for tensiometer is carried out using a vacuum pump for a range of suction from zero to 80 kPa and calibration curve can be determined to converse from voltage to pressure unit.

3. Testing Program

3.1 Soil specimen

Subsurface exploration carried out in this study indicated that most of near surface soils of Perth can be classified as poorly graded sand [12]. The soil specimen taken from a location near north end of Kewdale Rd, Perth was investigated. The sieve analysis and Atterberg limits test on this specimen indicated that the soil consists of 55.92 %, 41.48 % and 0.68 % of fine, medium and coarse sand respectively with only 1.93 % of silt and clay. Base on Atterberg limits test, the soil was categorised as non plastic.

The standard proctor test was conducted on this soil to obtain the compaction characteristic. The result of maximum dry density (MDD), optimum moisture content (OMC) and void ratio were 1.84 g/cm³, 12 % and 0.44 respectively. These three parameters were used as references of soil sample condition in shear

tests. For preparing shear test either in saturated or unsaturated condition, all the specimens were compacted in shear box at 100 % OMC to reach targeted MDD and void ratio.

In this study, 3 post compaction moisture contents were investigated. There were “as compacted moisture content” (i.e. OMC), “after drying” and “after wetting” moisture contents. “As compacted” moisture content was obtained by measuring the weight of water used during compaction. “After drying” moisture content resulted from weighing shear box together with compacted soil after finishing the air dried process for a couple of hours. “After wetting” moisture content was obtained by weighing shear box together with compacted soil after dripping distilled water into compacted soil. Back calculation method was then used by measuring this weight and comparing to “as compacted” weight.

3.2 Saturation of Tensiometer Probe

Tensiometer uses water as media to transfer suction or negative pressure from soil to ceramic disk and finally to sensor transducer. A presence of even a small air bubble within the water reservoir can affect the performance of tensiometer by increasing the response time. Saturation of the water within tensiometer is thus required. This is normally achieved by evacuating air from different parts of the device in a water-filled reservoir using a vacuum pump, as described in [13]. Normally, 2-3 hours of vacuuming with 90 kPa is appropriate for saturation.

3.3 Shearing Test on Saturated and Unsaturated Soil

A series of shear tests on saturated specimen were carried out to obtain effective stress parameters c' and ϕ' . Before and during shearing, compacted soil specimen together with shear box was submerged overnight in distilled water. Normal loads of 4 kg, 14 kg, 24 kg and 44 kg were applied both in single and multistage loading tests. A relatively slow horizontal displacement rate was maintained about 0.002 mm/s to assure a drained condition. Figure 2 shows the typical result of shearing test. The value of c' and ϕ' were 0 and 38.8° respectively.

Shearing test on unsaturated specimen was performed through a series of tests with similar normal stresses and displacement rate as in saturated condition. For unsaturated tests, soil specimen were not submerged and thus of negative pore water pressure. Firstly, compacted soil in the shear box was brought to direct shear machine and kept 30 minutes for equilibration of suction. During this period, the tensiometer was prepared to be attached to the top cap. To fix the placement of tensiometer to the top cap, clamping set was tightened in such a way that the tip of tensiometer (i.e. high air entry ceramic) has the same level with the top cap base. Water content during the test was maintained to be constant by covering the shear box with wet cloth to keep about 100% relative humidity. When suction become relatively constant, shearing force was then applied and all displacements, forces and suction were recorded. This process is performed towards all specimens with four values of moisture content, namely “after drying”, “as compacted” and “after wetting” moisture content. Figure 3 shows typical result of unsaturated specimens with 4 kg normal load.

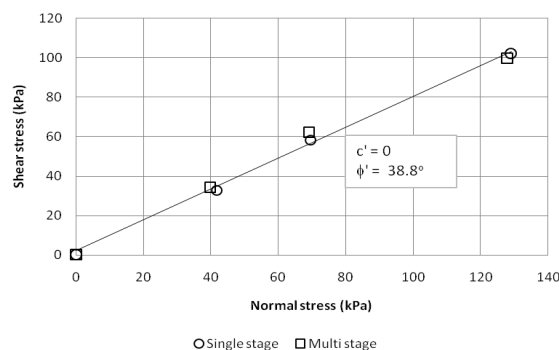

Figure 2. Failure envelope of saturated specimen

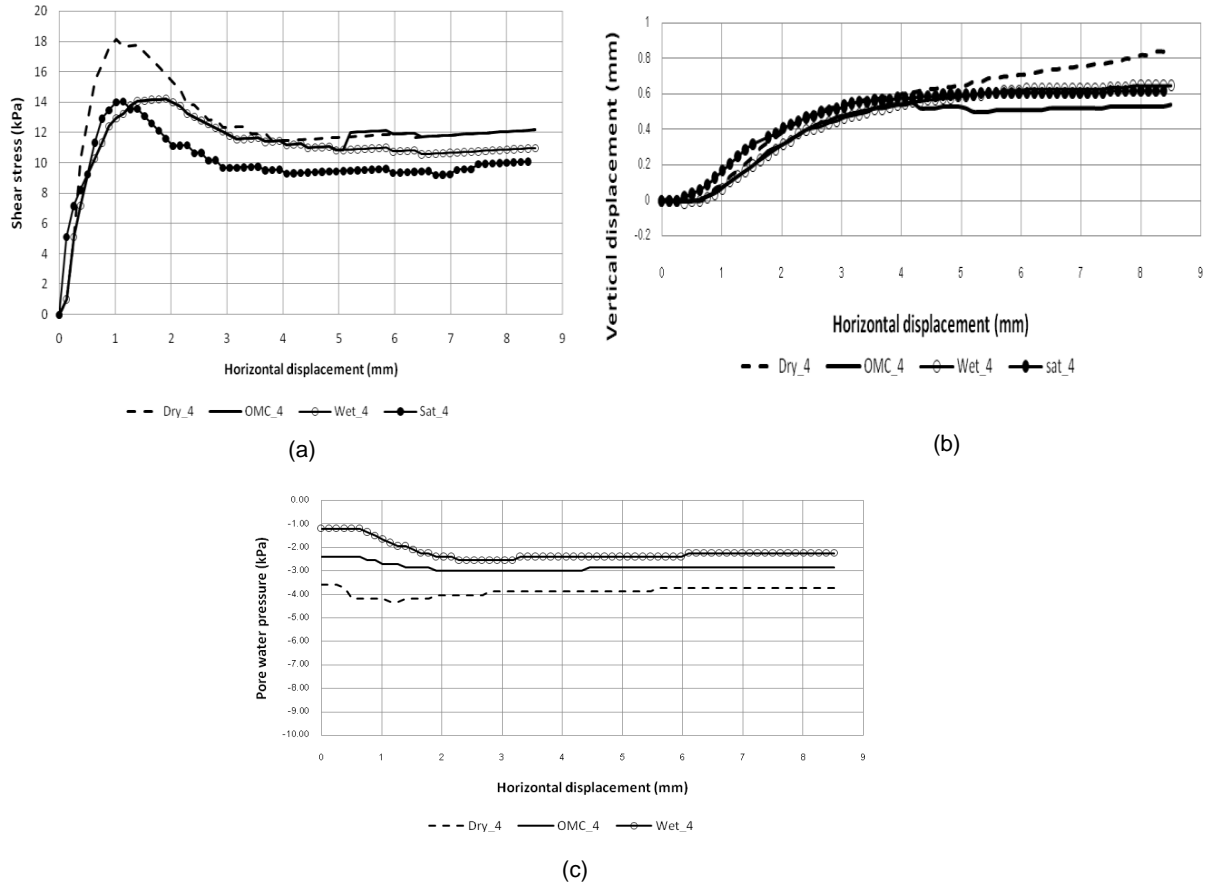

Figure 3. Unsaturated test results for 4 kg normal load

4. The Influence of Matric Suction to Shear Strength

Table 1 shows the summary of direct shear test from both saturated and unsaturated conditions. Matric suction was zero for saturated condition. Average normal stress was obtained from all normal stresses at peak stress (i.e. shear strength). Figure 4 shows trend lines of shear strength versus matric suction with various average normal stresses. It can be observed that moisture content influences matric suction and shear strength. The lower moisture content of the specimen, the higher value of matric suctions as well as shear strength. It indicates that contribution of suction towards shear strength is influenced by applied normal stress. The higher applied normal stress, the lower contribution of matric suction to shear strength.

Table 1. Peak stress, normal stress and matric suction from various normal loads

Moisture condition	Load 4 kg			Load 14 kg			Load 24 kg			Load 44 kg		
	Peak	Normal	Suction	Peak	Normal	Suction	Peak	Normal	Suction	Peak	Normal	Suction
After drying	18.14	11.38	4.18	42.09	40.44	4.93	62.86	69.02	5.22	106.39	128.5	3.73
As compacted	14.21	11.55	2.99	39.99	40.35	3.13	69.29	69.17	3.43	98.53	129.36	3.28
After wetting	14.24	11.55	2.39	39.01	41.07	1.8	63.98	70.25	1.94	101.16	127.93	2.09
Saturated	14.02	11.4	0	32.64	41.81	0	58	69.47	0	102.06	129.07	0
Ave normal stress		11.47			40.92			69.48			128.72	

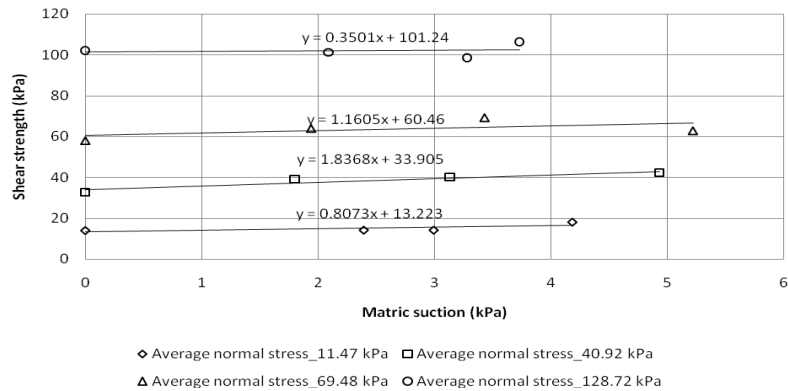

Figure 4. Shear strength trend line versus matric suction with various average normal stresses

5. Soil Water Characteristic Curve (SWCC)

SWCC is a graphical expression of relationship between matric suction and water content of the soil. The term water content can be degree of saturation, gravimetric water content or volumetric water content θ .

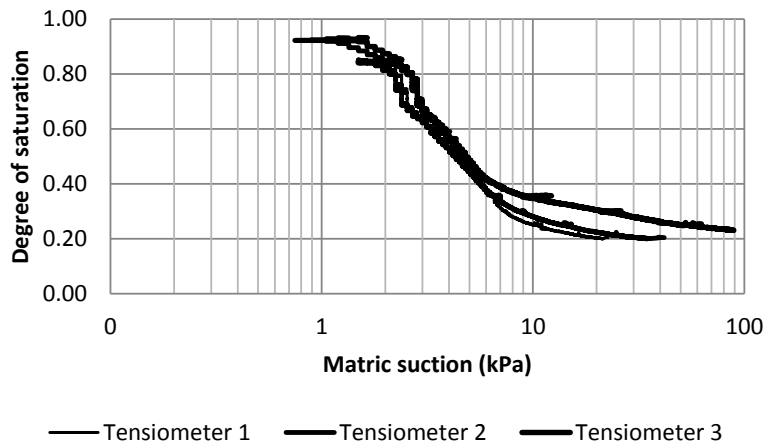

Figure 5. Soil-water characteristic curve

For SWCC test, a rigid PVC tube with 6.32 cm in diameter was used as a sample soil mould. Three small holes were created at the side of tube near the base, middle and top of PVC mould for attaching tensiometer installation. The mould was then attached to massive aluminium cylinder base. Adhesive, silicon sealant and electrical tape were utilised to prevent leakage between the mould and the aluminium base. Soil specimen was compacted in the mould using a vibratory table to achieve the 100 % MDD and 100 % OMC condition of soil. SWCC test was carried out using the drying path (desorption) method. The top part of the mould remains open so that pore water can be easily evaporated. The weight and suction of the specimen were recorded continuously using a digital balance and a data logger. Figure 5 shows SWCC, which its air entry suction appears to be about 1.5 kPa.

6. Conclusion

Suction-monitored direct shear test were performed on Perth poorly graded sand in various moisture contents and normal stresses. Very low matric suction ranging from 2 to 5 kPa is taking place in all tests. It is also found that matric suction is not only influenced by moisture content, but also by shearing behaviour of the soil sample. During shearing, matric suction tends to be increasing due to dilation until peak stress is achieved. After peak stress, both matric and shear stress are decreasing until constant value. Highest suction contribution to shear strength can be given by lowest normal stress. Therefore,

when the lower normal stress is applied, the higher contribution of suction takes place. Additionally, the continuous SWCC test was conducted and shows that its air entry suction is very low.

7. Acknowledgement

The writers acknowledge Indonesian Ministry of Education for funding through DIKTI Scholarship Project, and also many thanks to GERD of Kasetsart University, Thailand for providing technical support.

8. References

1. Houston S.L., Houston W.N., Wagner A.M., "Laboratory Filter Paper Suction Measurement", Geotechnical Testing Journal, Vol. 7, No. 2, 1985, pp 185-194.
2. Donald, I.B., "Effective Stresses in Unsaturated Non cohesive Soils with Controlled Negative Pore Pressure". M.Eng. Sc. Thesis, 1957, University of Melbourne, Melbourne, Australia.
3. Tarantino A., Tombolato S., "Coupling of Hydraulic and Mechanical Behaviour in Unsaturated Compacted Clay", Geotechnique 55, No. 4, 2005, pp 307-317.
4. Jotisankasa, A., Tapparnich, J., Booncharoenpanich, P., Hunsachainan, N. & Soralump, S., "Unsaturated Soil Testing for Slope Studies", Proc. International Conference on Slope, Geotechnique and Geosynthetics for Slope, 2010, Chiangmai, Thailand, pp 165-174.
5. Jotisankasa A., Mairaing W., "Suction-Monitored Direct Shear Testing of Residual Soils from Landslide-Prone Areas", Journal of Geotechnical and Geoenvironmental Engineering, Vol. 136, No. 3, 2010, pp 533-537.
6. Fredlund D.G. and Rahardjo H., "Soil Mechanics for Unsaturated Soil", John Wiley and Sons, 1993, New York.
7. Escario, V. and Saez, J., "The Shear Strength of Partly Saturated Soils", Geotechnique 36 (3), 1986, pp 453-456.
8. Gan J.K.M., Fredlund D.G., Rahardjo H., "Determination of the Shear Strength Parameters of an Unsaturated Soil using the Direct Shear Test", Canadian Geotechnical Journal, 25, 1988, pp 500-510.
9. Vanapalli S.K., Fredlund D.G. and Pufahl D.E., "The Relationship Between Soil-Water Characteristic Curve and the Soil Strength of a Compacted Glacial Till", Geotechnical Testing Journal, Vol. 19, No. 3, 1996, pp 256-268.
10. Vanapalli S.K., Fredlund D.G., Pufahl D.E. and Clifton A.W., "Model for the Prediction of shear Strength with Respect to Soil Suction", Canadian Geotechnical Journal, 33, 1996, pp 379-392.
11. Likos W.J., Wayllace A., Godt J., Lu N., "Modified Direct Shear Apparatus for Unsaturated Sand at Low Suction and Stress", Geotechnical Testing Journal, Vol.33, No. 4, 2010, pp 1-13.
12. Purwana, Y.M., "Grain size analysis and Atterberg Limits of Various Western Australia Soil Samples", Internal Report, 2010.
13. Jotisankasa, A. 2010. Manual for User of KU Tensiometer. 2nd edition. Geotechnical Innovation Laboratory, Geotechnical Engineering Research and Development Center, GERD, Kasetsart University.