

This is the author's version of an article published in EUROPEAN TRANSACTIONS ON ELECTRICAL POWER. Changes were made to this version by the publisher prior to publication. DOI: 10.1002/etep.539

Operational strategy for multi-converter based variable speed wind generator during network fault

S. M. Muyeen^{1*,†} and J. Tamura²

¹*Department of Electrical Engineering, The Petroleum Institute, P.O. Box 2533, Abu Dhabi, U.A.E*

²*Kitami Institute of Technology, 165 Koen-Cho, Kitami, Hokkaido 090-8507, Japan*

SUMMARY

This paper proposes novel multiconverter operation and control scheme for variable speed wind energy conversion system to withstand against grid fault. The full or partial rating frequency converters (FCs), in general, are widely used in variable speed wind turbine (VSWT) driven wind generators. Among the variable speed wind generators, permanent magnet synchronous generator (PMSG), which uses a full rating FC for grid interfacing, is drawing much attention nowadays due to its salient features. However, considering the factors such as higher-reliability, higher efficiency, and lower harmonics, the multiconverter based topology might be preferable instead of using a full rating FC. This paper proposes a coordinated control scheme for multiple parallel-connected FC units integrated with VSWT driving PMSG to augments the transient performance during a network disturbance. Multimode operation (inverter and rectifier) of the individual FC unit is another salient feature of this study. Copyright © 2010 John Wiley & Sons, Ltd.

KEY WORDS: frequency converter; multiconverter; permanent magnet synchronous generator (PMSG); transient stability; variable speed wind turbine (VSWT)

1. INTRODUCTION

Over the last decade the renewable energy sources such as solar, wind, biomass, wave, etc. have been investigated considerably from the viewpoint of increasing demand of electricity, depletion of fossil fuel, and global warming. Among those renewable energy sources wind energy stands as true alternatives to conventional technologies for electricity generation. Wind energy also has the clean energy feature which is important considering the fact of global warming. In 2008, 27 GW wind power has been installed all over the world, bringing world-wide installed capacity to 120.8 GW. This is an increase of 36% compared with the 2007 market, and represents an overall increase in the global installed capacity of about 28.8% [1]. From these statistics it can be predicted that huge number of wind turbine generator units are going to be connected to the existing power system. Therefore, the efficiency, stability, and reliability of the wind energy conversion system are the major concerns from the viewpoint of transmission system operators (TSOs), especially when bulk amount of electrical power is expected from wind farm. This study focuses on the stability and reliability issues of particular wind turbine generator system (WTGS) in which the generator is decoupled from the grid using a full-scale frequency converter (FC).

Transient stability analysis for fixed speed wind generators has been reported in many literatures [2–4]. But variable speed WTGS has recently become more popular than the fixed speed WTGS. A few types of variable speed wind turbine (VSWT) generator systems are commercially available, nowadays. Among those technologies, the direct drive concept is becoming very popular these days.

*Correspondence to: S. M. Muyeen, Department of Electrical Engineering, The Petroleum Institute, P.O. Box 2533, Abu Dhabi, U.A.E.

†E-mail: muyeen0809@yahoo.com

This study considers the stability and reliability issues of a wind farm composed of direct drive variable speed WTGSs.

Variable speed wind turbine driving a permanent magnet synchronous generator (PMSG) is considered in this study as the direct drive wind generator. Recently, PMSG is recognized as a promising technology for wind generator, both in direct-drive system and the system using a simple single-stage gearbox. One of the major advantages is the high power density of this type of machine [5,6]. The transverse flux design of it makes it possible to fish out some other benefits. The use of PMSG seems to be more prospective in wind power application from now on because the price for the rare-earth magnets decreases remarkably, in the last few years. Some authors have already been reported on VSWT-PMSG technology [7–20] including dynamic and transient characteristics analyses. However, the reliability issue of PMSG is not considered in those studies.

The VSWT-PMSG, in general, is connected to the power grid using a full-size, properly controlled FC technology. Two types of FC topologies are available these days. One is FC composed of generator side AC/DC converter, DC-link, and DC/AC inverter. The other one is the FC composed of Rectifier, DC-Chopper, DC-link, and DC/AC inverter. In both options, the electrical power generation from wind generator will be interrupted if the full-size FC is out-of-service because of any equipment fault or for scheduled maintenance. Therefore, the use of full-size FC in VSWT driven PMSG raises the issues of stability and reliability of the overall system. On the other hand, the efficiency of the MW-class FC operating at low power levels and its harmonics generated in the output voltage is another important issue to be addressed while using the full-size FC topology. Considering these viewpoints, GAMESA developed the concept of using multiconverter topology in the FC circuit that is suitable for variable speed operation of PMSG [21,22].

In that topology [21,22], multiple small capacity parallel-connected FC units are integrated to a PMSG with multiple 3-phase winding set, which are electrically and magnetically independent as shown in Figure 1. This system paves the way to achieve higher reliability, higher efficiency, and lower harmonics from VSWT-PMSG system. The general control scheme, efficiency, and harmonic analyses are reported with sufficient depth in Ref. [21,22]. However, the stability phenomena, and the detailed control strategy of multiple parallel-connected FCs, especially in the grid fault condition, are not reported in those works.

The transient characteristics analysis of multiple parallel-connected FC units used in variable speed WTGS application has been reported in Ref. [23] for the first time, so far we know. However, only single-line-to-ground (1LG) fault is analyzed in that preliminary study as the coordinated control among the units has not been considered therein. Therefore, it is not possible to withstand against severe three-line-to-ground (3LG) fault using that control scheme for all operating conditions and hence, this study focuses on a coordinated control scheme to augment stability and reliability of the multiple parallel-connected FC units, which is the continuation of the earlier study [23]. The necessity and novelty of the study are given as follows.

When only one FC unit is in operation and a severe 3LG fault occurs, it is not possible to stabilize the system maintaining the apparent power level of that small unit within acceptable range. The second FC unit cannot start operation instantly to take part for compensating the active and reactive power

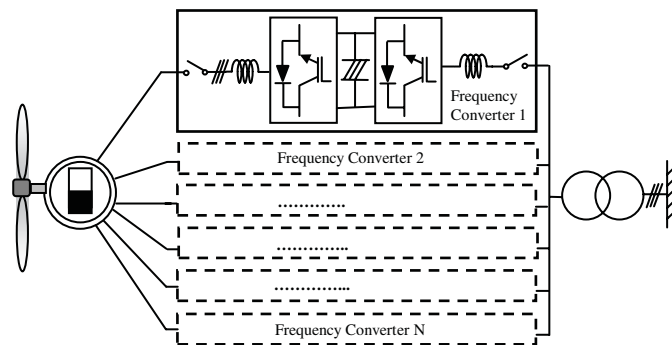

Figure 1. Schematic diagram of multifrequency converters of VSWT-PMSG.

requirements. This issue is resolved considering both inverter and rectifier operation mode in grid side inverters used in individual FC unit, which is one of the salient features of this study. A coordinated control scheme is developed for overall system considering advanced maximum power point tracking (MPPT) control, DC overvoltage protection, inverter/rectifier mode in grid side inverter of each FC unit. Both symmetrical and unsymmetrical faults are considered and the effectiveness of the proposed coordinated control scheme is verified by extensive simulation analysis, which has been done by laboratory standard power system simulator PSCAD/EMTDC.

2. WIND TURBINE MODELING

The mathematical relation for the mechanical power extraction from the wind can be expressed as follows [24]:

$$P_M = 0.5 \rho C_p(\lambda, \beta) \pi R^2 V_w^3 [W] \quad (1)$$

Where, P_M is the extracted power from the wind, ρ is the air density (kg/m^3), R the blade radius (m), V_w the wind speed (m/second), and C_p is the power coefficient which is a function of both tip speed ratio, λ , and blade pitch angle, β (deg). C_p is expressed in the next equations [25].

$$C_p(\lambda, \beta) = 0.5(\Gamma - 0.02\beta^2 - 5.6)e^{-0.17\Gamma} \quad (2)$$

$$\lambda = \frac{\omega_m R}{V_w}, \quad \Gamma = \frac{R}{\lambda} \frac{3600}{1609} \quad (3)$$

Where ω_m is the rotational speed (rad/second).

In Equations (2) and (3), the tip speed ratio given in Ref. [25] is revised in light of general definition and unit system is modified as well. Figure 2 shows characteristics between the wind turbine power P_M and the rotor speed ω_m for various wind speed, in which the locus of the maximum output power is shown by a dashed line. Equations (4) and (5) are considered for MPPT control as shown in Figure 3. MPPT control is adopted in the generator side converter, which ensures maximum power transfer to the AC grid. The characteristics of C_p depend on the wind speed and rotational speed. Equation (4) shows a relation between the optimal rotational speed, ω_{m_opt} , corresponding to the optimum power coefficient C_{p_opt} , and the wind speed, V_w . This expression is obtained by differentiating C_p with respect to ω_m , assuming that β equals zero.

The MPPT controller shown in Figure 3 determines the reference power, P_{ref} , for generator side converter based on linear functions as expressed in Equation (5a)–(5c). The control block takes wind speed and rotational speed of rotor as the input signals and generates the P_{ref} as output, which is used as the input of the cascaded control of generator side converter. Wind turbine should be operated at ω_{m_opt} as expressed in Equation (4) to achieve the power capture corresponding to P_{ref} . In addition, in the

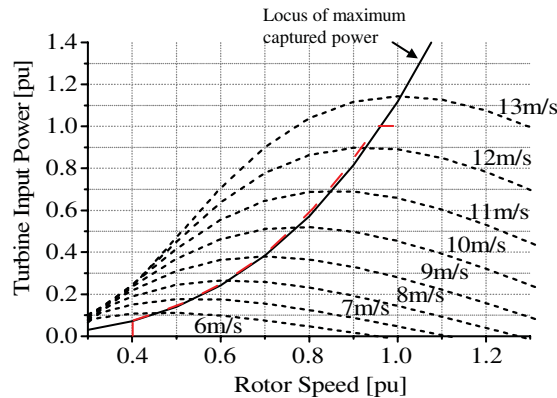

Figure 2. Wind turbine characteristics for variable speed operation.

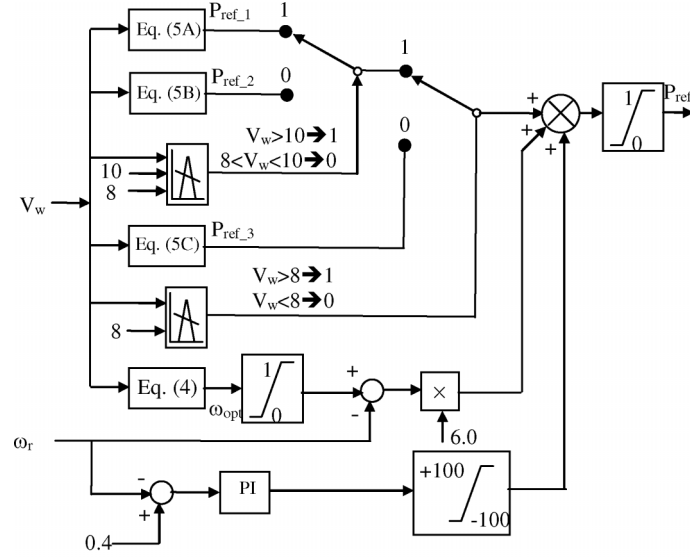

Figure 3. Block diagram for MPPT controller.

control block, it

$$w_{m_opt} = 0.0775 V_w [\text{pu}] \quad (4)$$

$$P_{ref_1} = 0.197V_w - 1.451 [\text{pu}] \quad (5a)$$

$$P_{ref_2} = 0.127V_w - 0.749 [\text{pu}] \quad (5b)$$

$$P_{ref_3} = 0.068V_w - 0.282 [\text{pu}] \quad (5c)$$

is ensured that the rotor speed ω_r does not go below 0.4 pu during the low wind speed, which is considered the minimum speed, in this study.

When the rotor speed ω_r goes beyond the rated speed of PMSG, then the pitch controller presented in Ref. [26] is considered to control the rotational speed. Therefore, output power will not exceed the rated power of the PMSG.

3. MULTICONVERTER OPERATION OF VSWT-PMSG

In this topology, the direct drive PMSG is connected to several small size four-quadrant fully controlled parallel-connected FC units and is electrically connected to the transformer as shown in Figure 1. Each FC unit is composed of two-voltage source converters (VSCs) connected back-to-back. The programmable logic controller (PLC) controls the operation and synchronization of different FC units. The real and reactive power references (P_{ref} and Q_{ref}) of individual FC is set by PLC. The control strategy of one FC unit is shown schematically in Figure 4.

The individual component modeling and control strategy are demonstrated below.

3.1. PMSG

In this topology, the multiple parallel-connected FC units are connected to a low speed, multipole PMSG with multiple sets of three-phase windings, which are electrically and magnetically independent as shown in Figure 1. However, for ease of simulation, only one set of 3-phase winding PMSG is used instead of three sets. It does not have any big impact as the operation and performance of parallel-connected FC units are the major concerns, in this study. In the simulation analyses, the PMSG model

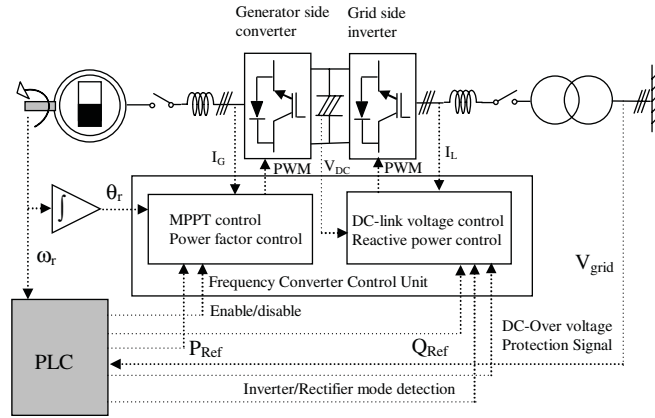

Figure 4. Control strategy of single frequency converter unit.

available in the package software PSCAD/EMTDC [27] is used. The nominal speed is considered as the maximum rotor speed, ω_{r_max} . The pitch controller activates when the rotor speed exceeds the maximum rotor speed of PMSG.

3.2. Modeling and control strategies of frequency converter

Each FC unit consists of generator side AC/DC converter, DC-link capacitor, and grid side DC/AC inverter. Each of converter/inverter is a standard 3-phase two-level unit, composed of six IGBTs and antiparallel diodes. The control strategy of each element is demonstrated below.

3.2.1. *Generator-side converter.* The well-known cascaded control scheme shown in Figure 5 is used as the control methodology of generator side converter. The inputs of the control unit are P_{ref} generated from MPPT control block, real and reactive powers of the PMSG, speed of the generator for calculating the angle, θ_r that is used in abc/dq transformation, and generator side current. Outputs are the reference voltages which generate the switching pulses for IGBT devices using pulse width modulation (PWM) technique. The converter is directly connected to the PMSG and therefore, its q -axis current is proportional to the active power. The d -axis stator current is proportional to the reactive power. The reactive power reference is set to zero for unit power factor operation. The active power reference, P_{ref} , is determined in such a way to provide the maximum power to the grid. However, when network disturbance occurs, as the terminal voltage, V_{grid} , of the high voltage side of

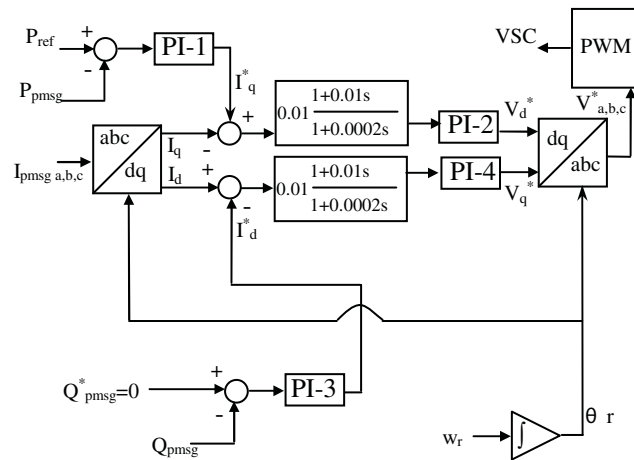

Figure 5. Control block diagram of generator side converter.

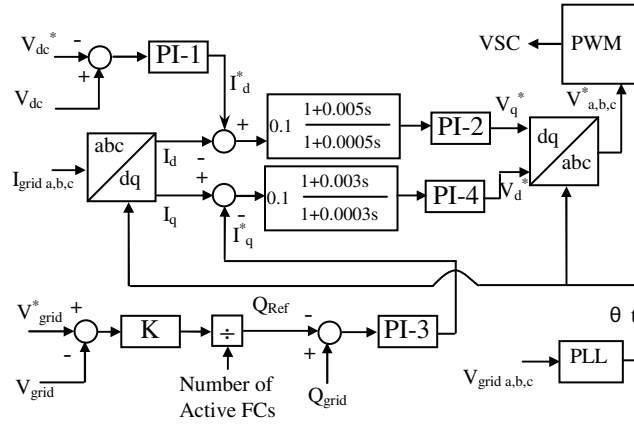

Figure 6. Control block diagram of grid side inverter.

considerably, it is not possible to provide maximum the transformer decreases power to the grid at that instant and any attempt to do so may causes system instability. Therefore, in this study, P_{ref} is varied according to the terminal voltage by multiplying P_{ref} with V_{grid} during the period from fault occurring to circuit breaker (CB) reclosing, which gives excellent transient performance as demonstrated in Section 5.

3.2.2. *Grid-side inverter.* In this study, cascade control scheme with independent control of active and reactive currents as shown in Figure 6 is applied to the control of grid side inverter. The dq quantities and three-phase electrical quantities are related to each other by reference frame transformation. The angle of the transformation is detected from the three phase voltages (v_a, v_b, v_c) at the high voltage side of the grid side transformer. The d -axis current can control the dc-link voltage. The dc voltage of the DC-link capacitor is controlled constant by two PI controllers. On the other hand, the q -axis current can control the reactive power of grid-side inverter. The aim of the control is to maintain the magnitude of the grid voltage at the desired reference level, no matter how many FC units are active at any particular instant. Q_{Ref} is determined based on this strategy as shown in Figure 6.

The carrier frequency of both converters is chosen 1050 Hz. The DC-link capacitor value is chosen 30 000 μ F. The rated dc-link voltage is 2.3 kV.

3.2.3. *DC-link overvoltage protection.* During a severe network disturbance such as short circuit fault, the front-end inverter connected directly to the grid has to provide sufficient reactive current to support the grid. At the same time, as the grid voltage collapses, real power cannot be transmitted to the grid side. As a result, DC-voltage of DC-link capacitor increases rapidly, which impede the normal operation of the FC unit. Therefore, overvoltage protection scheme using the braking chopper is taken into consideration in this study as shown in Figure 7.

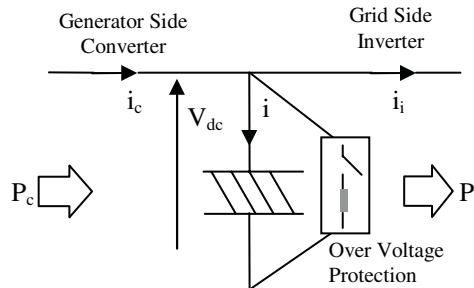

Figure 7. Over voltage protection scheme of DC-link.

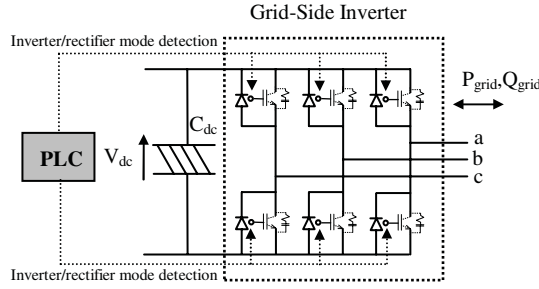

Figure 8. Inverter/rectifier operation scheme.

The braking chopper is modeled in the dc-link in order to protect the DC-link capacitor during fault situation. The chopper is activated when the dc-link voltage increases over the predefined limit and dissipates active power in the resistance during the voltage dip in the grid.

3.2.4. *Inverter/rectifier operation mode.* Multiple parallel-connected FCs used in variable speed wind power generation system need special operation technique to withstand against transient condition. When all FC units are in operation, grid side real and reactive power during network disturbance can be controlled easily without exceeding the rated power capacity of individual unit. However, if the fault occurs when only a single FC unit is in operation, it might not be possible to control the real and reactive power due to its small apparent power capacity. If the FC unit is shutdown during the situation above, the reliability of the system deteriorates.

One approach to overcome that problem in grid fault condition is to switch on another FC unit instantly, which, however, may not be appropriate for a few reasons. Reference power generation and instant restoring of the DC-link voltage for the newly joined FC unit are difficult, especially when the system is not operating at normal condition. These issues are resolved, in this study, by considering inverter/rectifier operation mode. When a FC unit is not in service, its grid side inverter is kept in operation by using it as rectifier as shown in Figure 8, so that the DC-link voltage can be maintained close to rated value and the inverter can control real and reactive power instantly by switching it into inverter mode when required. The inverter/rectifier mode detection signal will be sent to the grid side inverter of each FC unit from PLC as shown in Figure 4.

4. MODEL SYSTEM

The model system used for the transient stability analysis of VSWT-PMSG is shown in Figure 9, where PMSG is connected to the infinite bus through three parallel-connected FCs each rated at 1.0 MVA, a step-up transformer, and double circuit transmission line. The parameters of the PMSG are shown in Table I. The system base is 3.0 MVA.

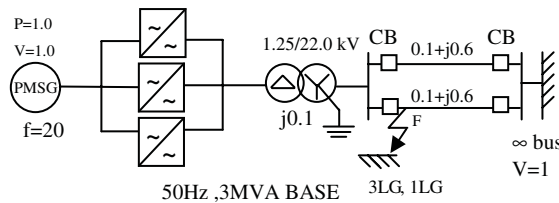

Figure 9. Model system.

Table I. Generator parameters.

Rated power	3 (MVA)	Stator resistance	0.01(pu)
Rated voltage	1.0 (kV)	d -axis reactance	1.0(pu)
Frequency	20 (Hz)	q -axis reactance	0.7(pu)
Number of poles	150	Field flux	1.4(pu)
H	3.0 (sec)		

5. SIMULATION RESULTS

The operational characteristics of the proposed system during network disturbance are analyzed in this section. Recently, wind farm grid codes are developed in different countries for suitable grid connectivity during normal operation and network fault condition. The wind farm grid codes are more or less similar. In this study, the simulation results are described in light of the recent grid code, set by E.On Netz [28,29]. The fault ride-through (FRT) requirement imposes on a wind power generator to remain operation connected to the network during network fault. Disconnection from the grid may worsen a grid situation and can threaten the security standards when wind penetration is high.

The time step and simulation time have been chosen as 0.00001 and 10 seconds, respectively. The symmetrical 3LG (three-line-to-ground) and unsymmetrical 1LG (single-line-to-ground) faults are considered as the network disturbance. The fault occurs at 0.1 second. The CBs on the faulted line are opened at 0.2 second, and at 1.0 second the CBs are reclosed. In multiconverter topology, the number of active FC unit depends on the available aerodynamic torque. In the transient stability analysis, the wind speed is kept constant at 12.4 and 7.8 m/second, respectively, in two cases, where three FCs and one FC are operated, respectively, at rated condition, assuming that the wind speed does not change dramatically within this small time duration. Simulations have been done by using PSCAD/EMTDC [27]. The performance of the overall coordinated control strategies including the inverter/rectifier mode switching of grid side inverter of each FC unit are demonstrated in the following sections.

5.1. Transient analysis with all FC units operated

In this analysis, wind speed is kept constant at rated speed, and therefore three FC units are working at rated condition. As all FC units are in operation, the power rating of individual unit can be maintained within the rated value.

Case 1: Firstly the transient performance is evaluated for most severe 3LG fault. When the fault occurs, the reactive power demand is compensated by all three FC units as described in Section 3.2.2. As a result, the terminal voltage can be returned back to the prefault level as shown in Figure 10. The responses of real and reactive power at the AC grid are shown together in Figure 11. The real power reference of the FC is shown in Figure 12, which ensures the MPPT control as depicted in Section 2. The response of rotor speed of PMSG is shown in Figure 13, which is found to be stable. The rotor

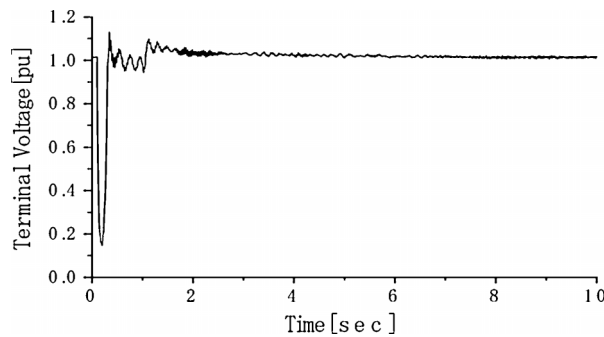

Figure 10. Terminal voltage of AC grid (3FC, 3LG).

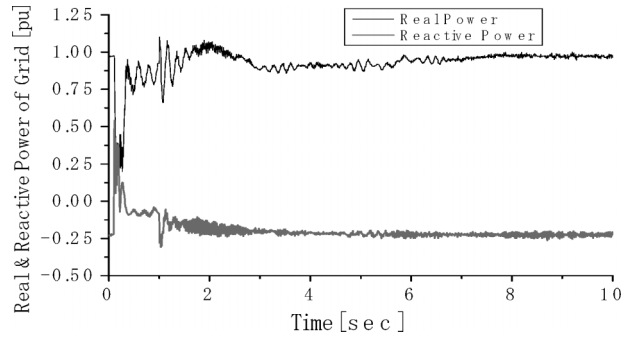

Figure 11. Real and reactive powers at AC grid (3FC, 3LG).

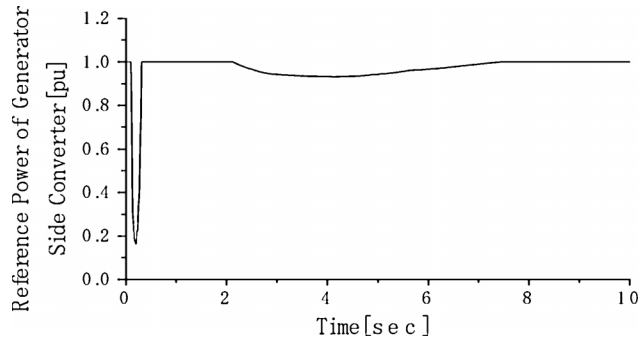

Figure 12. Real power reference of FCs (3FC, 3LG).

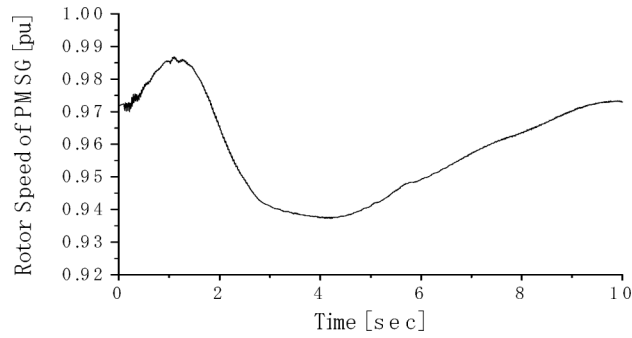

Figure 13. Rotor speed of PMSG (3FC, 3LG).

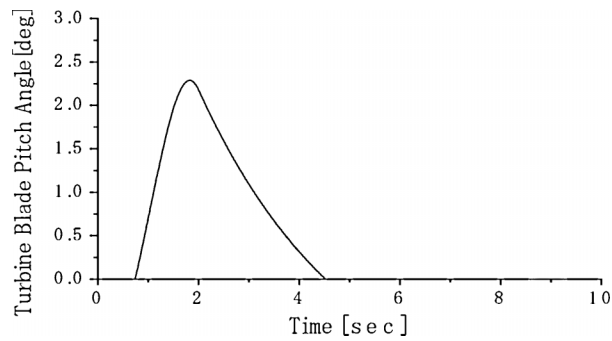

Figure 14. Wind turbine blade pitch angle (3FC, 3LG).

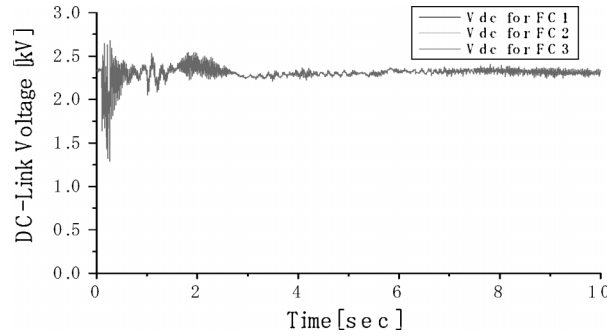

Figure 15. DC-link voltage of FCs (3FC, 3LG).

speed of PMSG is maintained below the rated speed by pitching the wind turbine blades as shown in Figure 14. The overvoltage protection unit can maintain the DC-link voltages of each FC unit within the acceptable range as can be seen from Figure 15.

Case 2: The system behavior for 1LG fault when all FC units are in operation is investigated. The responses of terminal voltage, rotor speed, and DC-link voltage are shown in Figures 16–18, respectively, from which it is seen that the system is stable after the occurrence of 1LG fault.

Therefore, it is found that, under the proposed control strategy, the grid code requirement is fulfilled during the network disturbances when all parallel-connected FC units are in operation.

5.2. Transient analysis with partial number of FC units operated

In this case, it is assumed that wind speed is low (7.8 m/second), and therefore, only one FC unit is operating at rated condition. Therefore, when a network disturbance occurs at the grid side, there is a possibility that the active FC unit will be overloaded for controlling both real and reactive power. Two cases are considered in this analysis as given below.

Case 1: It is considered that a severe 3LG fault occurs at the grid side. The apparent power response of grid side inverter of the active FC unit is shown in Figure 19, from which it is seen the unit is overloading after the fault. Therefore, there is a possibility that the unit will be shutdown, which is not acceptable and not desirable from a reliability point of view.

Case 2: To compensate active and reactive powers during the grid fault condition, another FC unit is needed to be switched on instantly. As proposed in Section 3.2.4, the remaining grid side inverters of the inactive FC units are operating in rectifier mode. Then, receiving the response from PLC unit, the second FC unit is switched on into inverter mode from the rectifier mode. As a result, FC units 1 and 2 can compensate the real and reactive power demand cooperatively, which can reduce the overloading of the first FC unit. The responses of reference power, rotor speed, terminal voltage, reactive power, and DC-link voltage in this analysis are shown in Figures 20–24. The system is found to be stable,

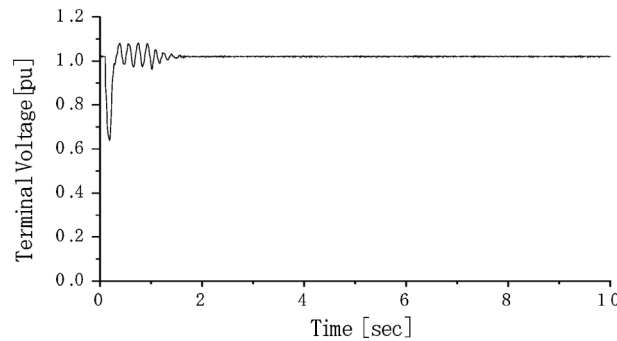

Figure 16. Terminal voltage of AC grid (3FC, 1LG).

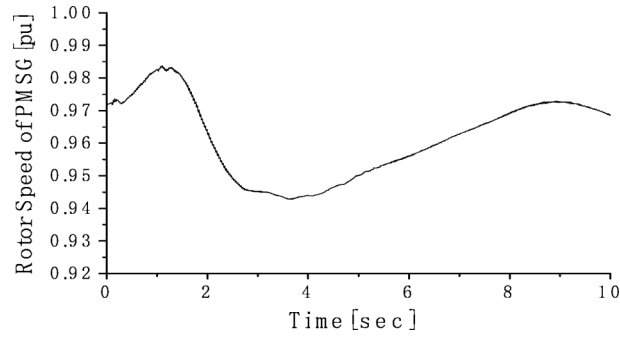

Figure 17. Rotor speed of PMSG (3FC, 1LG).

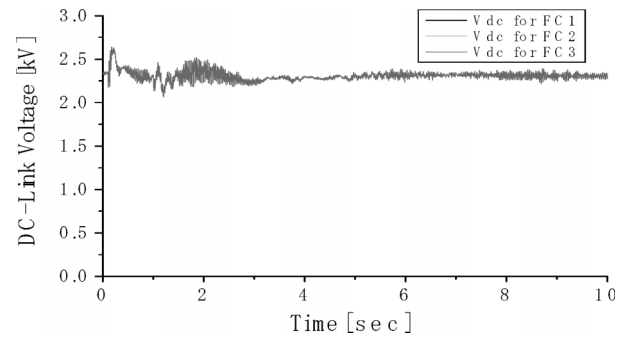

Figure 18. DC-link voltage of FCs (3FC, 1LG).

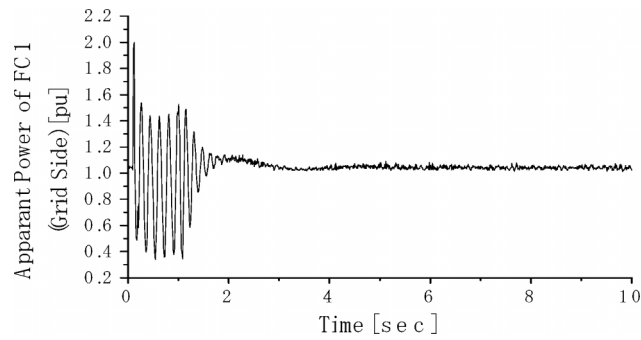

Figure 19. Apparent power of grid side inverter of FC1 (1FC, 3LG).

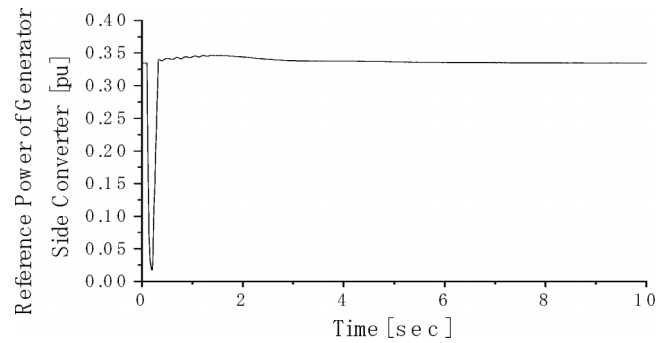

Figure 20. Real power reference of FC1 (2FC, 3LG).

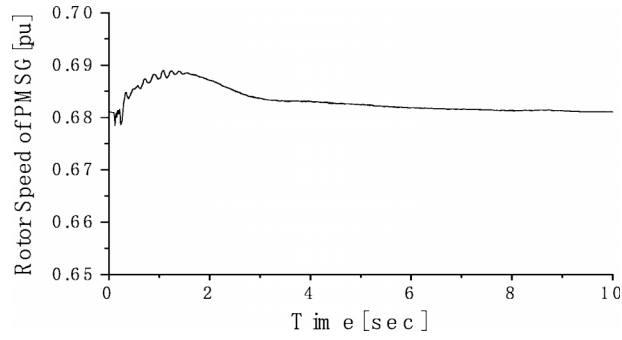

Figure 21. Rotor speed of PMSG (2FC, 3LG).

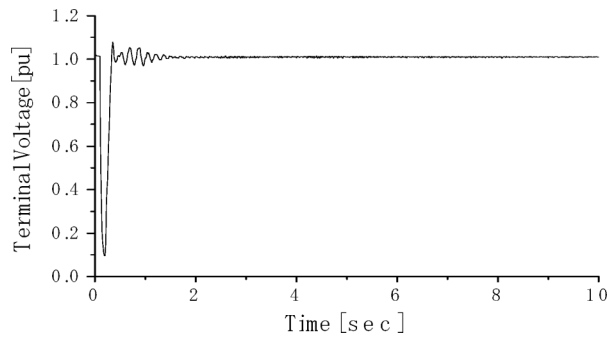

Figure 22. Terminal voltage of AC grid (2FC, 3LG).

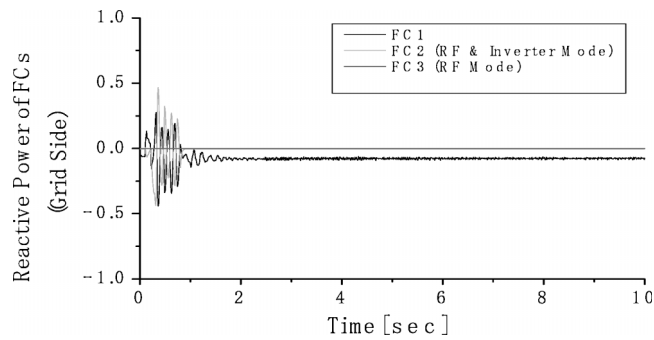

Figure 23. Reactive power of grid side inverters of two FC units (2FC, 3LG).

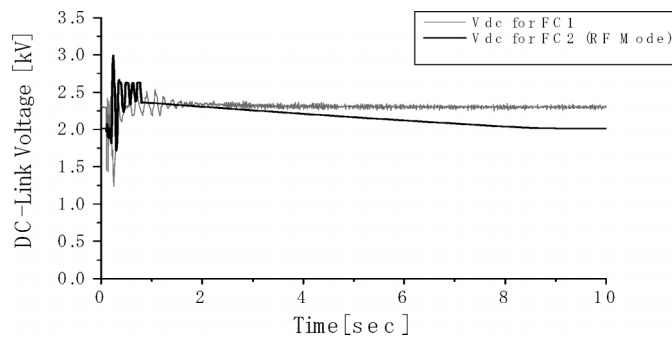

Figure 24. DC-link voltage of FCs (2FC, 3LG).

which can be understood from Figure 21. The DC-link voltage is kept active before the occurrence of the fault in the second FC unit operating in rectifier mode as can be seen from Figure 24. Therefore the second unit can instantly take part in controlling reactive power as shown in Figure 23 along with the first unit during network disturbance, and thus can avoid overloading of the first FC unit. Therefore, it can be concluded that the concept of inverter/rectifier mode change in multiconverter operation can enhance the stability of the system during a grid fault.

6. CONCLUSIONS

In this study, the fault ride through of VSWT-PMSG has been analyzed, in which the control performance of the multiple parallel-connected FCs during the grid fault is focused that is very important from the view point of system reliability. Detailed modeling and control strategies of the overall system have been presented and discussed. The fault ride through performance is evaluated in light of the wind farm grid code considering both symmetrical and unsymmetrical faults while all/single FC units are in operation with full load condition. It is found that special coordinated control technique is necessary to achieve the fault ride through when multiple FC based topology is used. Finally, it is concluded that the proposed control scheme of changing inverter/rectifier mode in the grid side inverter of the multiple parallel-connected FC units is an effective means to enhance the fault ride through capability of the VSWT driven PMSG that connects the grid. Though the analysis is performed using VSWT-PMSG, the concept can be adapted in any other wind generator that use full scale frequency converter for interfacing with the grid.

REFERENCES

1. The Global Wind Energy Council, GWEC Latest News, 2009. "US and China in race to the top of global wind industry," February, 2009, [Online], <http://www.gwec.net/>.
2. Abdin E.S, Xu W. Control design and dynamic performance analysis of a wind turbine induction generator unit. *IEEE Transactions on Energy Conversion* 2000; **EC-15**(1):91.
3. Muyeen SM, Ali MH, Rion T, Toshiaki M, Junji T. Transient stability enhancement of wind generator by a new logical pitch controller. *IEEJ Transaction on Power and Energy* 2006; **126-B**(8):742–752.
4. Muyeen SM, Mohd. Hasan A, Takahashi R, Murata T, Tamura J. Transient stability analysis of grid connected wind turbine generator system considering multi-mass shaft modeling. *Electric Power Components & Systems* 2006; **34**(10):1121–1138.
5. Peter V. *Electrical machines and drives – a space vector theory approach*, Oxford University Press: New York, United States, 1992.
6. Miller TJE. *Brushless permanent-magnet and reluctance motor drives*, Oxford University Press: New York, United States, 1989.
7. Cutululis NA, Ceanga E, Hansen AD, Sørensen P. Robust multi-model control of an autonomous wind power system, *Wind Energy* **9**(5): 2006; 399–419.
8. Tan K, Islam S. Optimum control strategies in energy conversion of PMSG wind turbine system without mechanical sensors. *IEEE Transactions on Energy Conversion* 2004; **19**(2):392–399.
9. Chinchilla M, Arnaltes S, Busgos JC. Control of permanent-magnet synchronous generators applied to variable-speed wind-energy systems connected to the grid. *IEEE Transactions on Energy Conversion* **21**(1): 2006; 130–135.
10. Zhang J, Cheng M, Chen Z. Nonlinear control for variable-speed wind turbines with permanent magnet generators. Proceeding of International Conference on Electrical Machines and Systems (ICEMS 2007), Seoul (Korea), 2007; 4–6.
11. Morimoto S, Nakamura T, Takeda Y. Power maximization control of variable-speed wind generation system using permanent magnet synchronous generator. *IEEJ Transaction on Power and Energy* 2003; **123-B**(12):1573–1579.
12. Muyeen SM, Takahashi R, Murata T, Tamura J, Ali MH. Transient stability analysis of permanent magnet variable speed synchronous wind generator. Proceedings of International Conference on Electrical Machines and Systems 2007 (ICEMS 2007), Seoul (Korea), 2007; 288–293.
13. Muyeen SM, Takahashi R, Murata T, Tamura J. Transient stability enhancement of variable speed wind turbine driven PMSG with rectifier-boost converter-inverter. CD Record of XVIII International Conference on Electrical Machines (ICEM 2008), Ref. No.764, Portugal, Sep 6–9, 2008.
14. Senjyu T, Tamaki S, Urasaki N, Uezato K, Funabashi T, Fujita H. Wind velocity and position sensorless operation for PMSG wind generator. The Fifth International Conference on Power Electronics and Drive Systems, 2003. PEDS 2003, Vol.1, pp. 787–792.

15. Haraguchi H, Morimoto S, Sanada M. Suitable design of a PMSG for a large-scale wind power generator. *Conference CDROM of IEEE Energy Conversion Congress and Exposition (ECCE)*, 2009; 2447–2452. USA.
16. Haraguchi H, Morimoto S, Sanada M. Suitable design of a PMSG for a small-scale wind power generator. International Conference on Electrical Machines and Systems (ICEMS), Tokyo (Japan), 2009.
17. Li H, Chen Z. Optimal direct-drive permanent magnet wind generator systems for different rated wind speeds. European Conference on Power Electronics and Applications, 2007.
18. Wai RJ, Lin CY, Chang YR. Novel maximum-power-extraction algorithm for PMSG wind generation system. *IET Electric Power Applications* 2007; **1**(2):275–283.
19. Brahmi J, Krichen L, Ouali A. Sensorless control of PMSG in WECS using artificial neural network. 6th International Systems, Signals and Devices (SSD '09), 2009.
20. Hansen AD, Michalke G. Multi-pole permanent magnet synchronous generator wind turbines' grid support capability in uninterrupted operation during grid faults. *IET-Renewable Power Generation* 2008; **3**(3):333–348.
21. Andresen B, Birk J. A High Power Density Converter System for the Gamesa G10x 4.5 MW Wind Turbine. 12th European Conference on Power Electronics and Applications (EPE 2007), Aalborg (Denmark), 2007.
22. Birk J, Andresen B. Parallel-connected converters for optimizing efficiency, reliability and grid harmonics in a wind turbine. 12th European Conference on Power Electronics and Applications (EPE 2007), Aalborg (Denmark), 2007.
23. Muyeen SM, Takahashi R, Murata T, Tamura J. Multi-converter operation of variable speed wind turbine driving permanent magnet synchronous generator during network fault. International Conference on Electrical Machines and Systems (ICEMS2009), Conference CDROM, Paper No. 39, Tokyo, Japan, November 2009.
24. Heier S. *Grid integration of wind energy conversion system*, John Wiley & Sons Ltd.: Chichester, UK, 1998.
25. Wasynczuk O, Man D.T, Sullivan J.P. Dynamic behavior of a class of wind turbine generators during random wind fluctuations. *IEEE Transactions on Power Apparatus and Systems* 1981; **PAS-100**(6):2837–2854.
26. Muyeen SM, Murata T, Tamura J. *Stability augmentation of a grid-connected wind farm*, Springer: United Kingdom, 2008.
27. *PSCAD/EMTDC Manual*. Manitoba HVDC Research Center, Canada: 1994.
28. On Netz E. Grid Code, High- and Extra-High Voltage, April 2006, available at www.eon-netz.com/.
29. Bharat S, Singh SN. Wind power interconnection into the power system: a review of grid code requirements. *The Electricity Journal* 2009; **22**(5):54–63.